

Heller

HAWKER Hurricane Mk IIc

The prototype made its first flight on 6 November 1935. A total of 14,230 Hurricanes were built.

Wingspan	12,19 m
Length	9,82 m
Height	3,98 m
Speed	530 km/h

Der Prototyp dieses Flugzeugs startete zum ersten Mal am 6 November 1935. Im ganzen wurden 14230 Hurricanes hergestellt.

Spannweite	12,19 m
Länge	9,82 m
Höhe	3,98 m
Geschwindigkeit	530 km/h

Il prototipo ha effettuato il suo primo volo il 6 Novembre 1935. Gli Hurricane costruiti sono stati in tutto 14230.

Apertura alare	12,19 m
Lunghezza	9,82 m
Altezza	3,98 m
Velocità	530 km/h

Prototypen flög för första gången den 6 november 1935. Ett sammanlagt antal om 14230 Hurricane-plan byggdes.

Vingbredd	12,19 m
Längd	9,82 m
Höjd	3,98 m
Hastighet	530 km/t

Le prototype effectua son premier vol le 6 novembre 1935. Un total de 14230 Hurricane furent construits.

Envergure	12,19 m
Longueur	9,82 m
Hauteur	3,98 m
Vitesse	530 km/h

El prototipo efectuó su primer vuelo el día 6 de noviembre de 1935. Se construyeron en total 14230 Hurricane.

Envergadura	12,19 m
Longitud	9,82 m
Altura	3,98 m
Velocidad	530 km/h

Het prototype oefende zijn eerste vlucht op 6 november 1935 uit. Er werden in totaal 14230 Hurricanes gebouwd.

Spanwijdte	12,19 m
Lengte	9,82 m
Hoogte	3,98 m
Snelheid	530 km/u

Prototyypin suoritti ensimmäisen lentonsa 6 marraskuuta 1935. Yhteensä 14230 Hurricane-konetta rakennettiin.

Siipien väli	12,19 m
Pituus	9,82 m
Korkeus	3,98 m
Nopeus	530 km/t

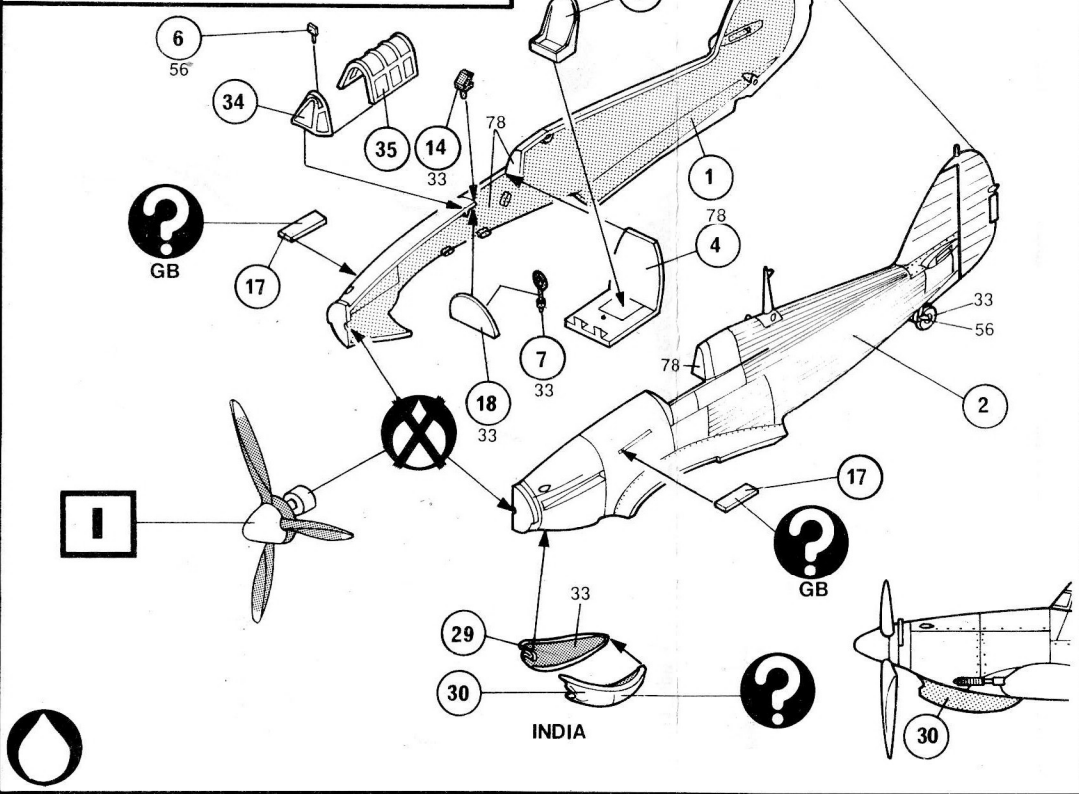
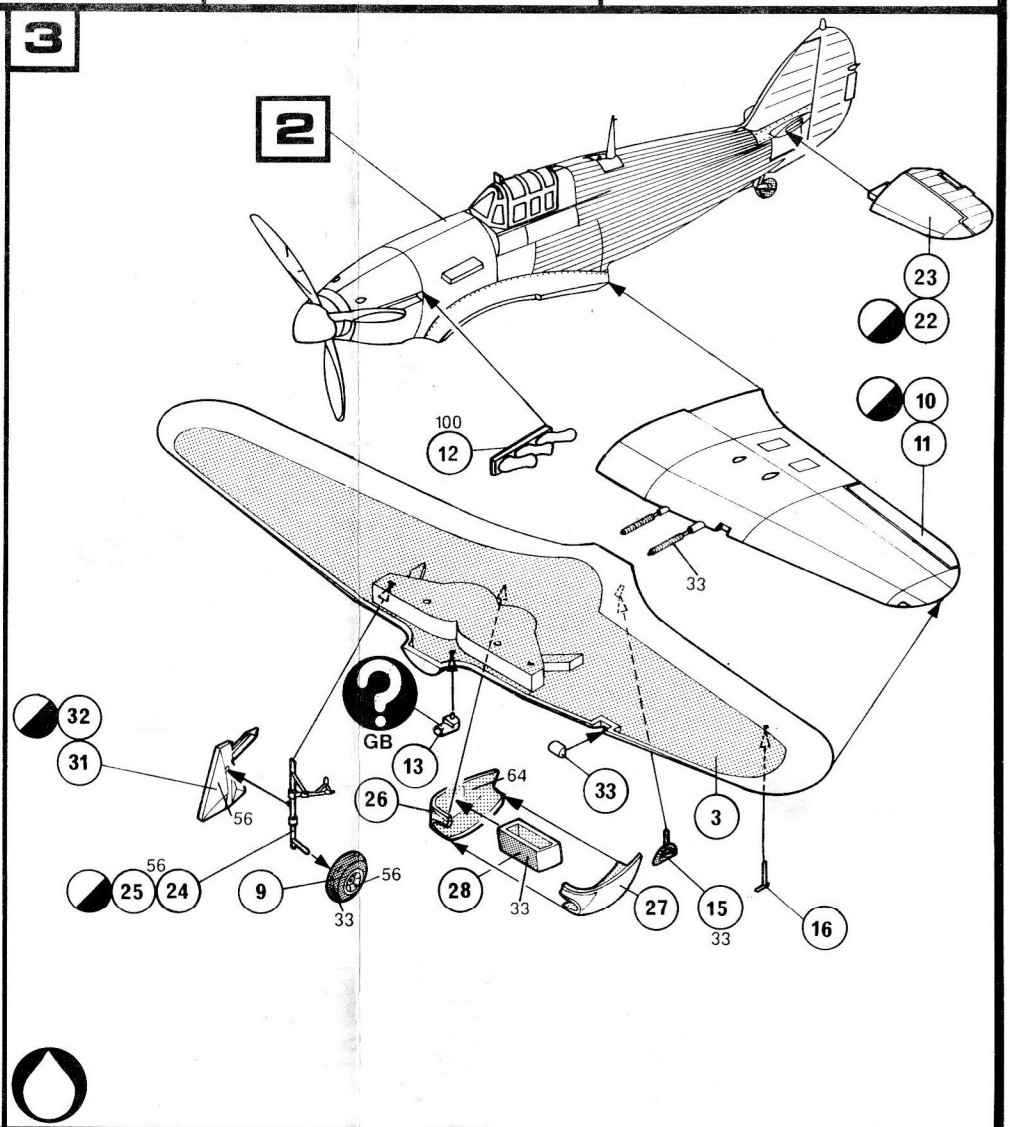
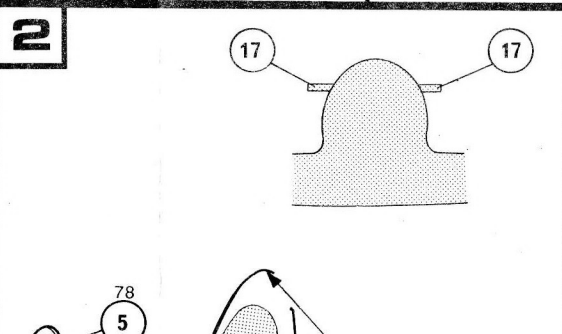
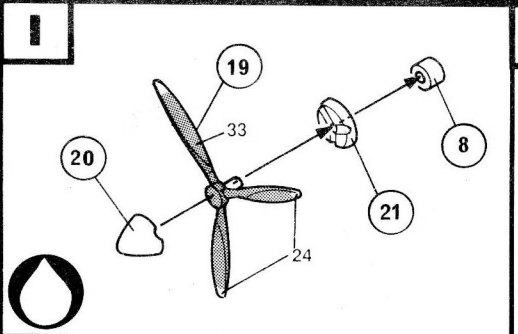

INDIA: MkIIc. Indian Air Force 1 Squadron 1944



GB: MkIIc. R.A.F 253 Squadron 1941/42

