



## SpPz 2 "Luchs" A2 SFOR

Der ab 1975 bei der Bundeswehr in den Panzeraufklärungsбатаillonен eingesetztе Spähpanzer 2 (8 x 8) "Luchs" ist gut gepanzert, verfügt über eine integrierte ABC-Schutzanlage und zeichnet sich durch äußerst leise Fahrgeräusche aus. Die acht großvolumigen Niederdruckreifen weisen Notlaufeigenschaften auf, und für Geschwindigkeiten bis zu 30 km/h können alle vier Achsen gelenkt werden. Von einem DB 10-Zylinder Vielstoffmotor mit 389 PS angetrieben, erreicht das Fahrzeug eine Höchstgeschwindigkeit von bis zu 90 km/h auf der Straße. Die Besatzung besteht aus Kommandant, Vorwärtsfahrer, Richtschütze und Rückwärtsfahrer/Tastfunker. Im Verlauf seiner Einsatzzeit wurde das Fahrzeug auch mehrfach modernisiert und erhielt in der Version SpPz 2 "Luchs" A2 u.a. ein Wärmebild-Ziel und Beobachtungsgerät. Als Bewaffnung dienen eine Bordmaschinenkanone RH 202 Mk 20 mm mit Munitionswechseinrichtung und, als Sekundärwaffe, ein 7,62 mm MG 3. Der SpPz 2 "Luchs" A2 wurde im Rahmen der IFOR in Kroatien und Bosnien als Konvoibegleitschutz eingesetzt. Er dient nun bei der SFOR in Bosnien und Herzegovina im Rahmen der Friedenssicherung. Ein Teil der dort eingesetzten Fahrzeuge, wie auch ein Teil der jüngst in Mazedonien stationierten, ist mittlerweile mit einer GPS-Navigationsanlage, einem Kreiselkompaß und einer zusätzlichen Datenfunkantenne kampfwertgesteigert worden.

## SpPz 2 "Luchs" A2 SFOR

The 8 x 8 "Luchs" reconnaissance vehicle that has been used in the Germany army reconnaissance batallions since 1975 is well armoured, has an integral NBC protection system and is also characterized by extremely low running noise. The eight large low pressure tyres have run-flat properties and all four axles can be steered at speeds up to 30 km/h. Driven by a DB 10 cylinder multi-fuel 389 hp engine, the vehicle develops a maximum speed of 90 km/h on the road. The crew consists of commander, forward-facing driver, gunner, and rear-facing driver/radio operator. During its service life the vehicle was also modified several times and the SpPz 2 "Luchs" A2 version was given a thermal image aiming and observation system. The armament consists of an RH 202 Mk 20 mm cannon with variable ammunition feeder and as secondary armament a 7.62 mm MG 3. The SpPz 2 "Luchs" A2 was used for convoy escort duties by the IFOR in Croatia and Bosnia. It is now used by the SFOR peacekeeping mission in Bosnia and Herzegovina. Some of the vehicles used there, and likewise some of those more recently stationed in Macedonia, have in the meantime been upgraded with a GPS navigation system, a gyro compass and an additional data radio antenna.

Form hergestellt und im Eigentum von Revell AG/Revell Monogram Inc. Widerrechtliche Nachahmungen werden gerichtlich verfolgt.

Ce produit est propriété de la société Revell AG/Revell Monogram Inc. Toute utilisation ou duplication frauduleuse fera l'objet de poursuites en justice.

Modelado y en propiedad de Revell AG/Revell Monogram Inc. Imitaciones ilícitas serán perseguidas por la ley.

Forma prodotta dalla Revell AG/Revell Monogram Inc. e di proprietà della stessa impresa, la quale procederà legalmente contro ogni imitazione abusiva.

Malli on Revell AG/Revell Monogram Inc. valmistama ja omaisuutta. Laittoaan kopiointiin tullaan puuttamaan oikeudellisiin toimin.

Formen er produsert og eies av Revell AG/Revell Monogram Inc. Etterligning uten tillatelse vil bli gjenstand for rettslig forfølgelse.

Produkcja i prawa własności firmy Revell AG/Revell Monogram Inc. Nielegalne podrobienie jest zabronione pod odpowiedzialnością sądową.

Model, Revell AG/Revell Monogram Inc. firmasının mülkiyeti altında imal edilmiştir. Kanuna aykırı taklitler mahkemece takip edilecektir.

A forma előállításja és a tulajdonjog birtokosa a Revell AG/Revell Monogram Inc. A jogellenes utántárat és hamisítványokat bíróságlag üldöztik.

Mould manufactured by and property of Revell AG/Revell Monogram Inc. Illegal imitations are subject to prosecution.

Vorm vervaardigd door en eigendom van Revell AG/Revell Monogram Inc. Onrechtmatige nabootsingen worden gerechtelijk vervolgd.

Formas producidas e de propriedade da Revell SA/Revell Monogram Inc. Cópias não autorizadas serão processadas juridicamente como determinado na lei.

Modellen tillverkad av och tillhör Revell AG/Revell Monogram Inc. All kopiering beivras enligt lagen om upphovsrätt.

Formen er fremstillet af Revell AG/Revell Monogram Inc. som også har ejendomsret. Lovstridige efterligninger sagsøges.

Модел изготвена и владеея самостоятелно фирмата Revell AG/Revell Monogram Inc. Протоизважените подделки преследуват се в съдебен порядък.

Η μορφή κατασκευάστηκε και περιήλθε στην ιδιοκτησία της Revell AG/Revell Monogram Inc. Οι παράνομες μιμήσεις θα καταδιώκονται δικαστικώς.

Tvar byl vytvořen firmou Revell AG/Revell Monogram Inc. a je jejím vlastnictvím. Proti nezákonným napodobením se bude postupovat soudní cestou.

Forma je proizvedena in je vlasništvo Revell AG/Revell Monogram Inc. Neovlašene kopije bodo pravno kažnjene.

# Verwendete Symbole / Used Symbols

Bitte beachten Sie folgende Symbole, die in den nachfolgenden Baustufen verwendet werden.

**Veillez noter les symboles indiqués ci-dessous, qui sont utilisés dans les étapes suivantes du montage.**

Por favor, preste atención a los símbolos indicados a continuación, a utilizar en las siguientes fases de construcción.

**Si prega di fare attenzione ai seguenti simboli che vengono usati nei susseguenti stadi di costruzione.**

Huomina seuraavat symbolit, jotta käytätään seuraavissa kokonaisuvaiheissa.

**Legg merke til symbolene som benyttes i monteringsstinnene som følger.**

Proszę zwracać na następujące symbole, które są użyte w poniższych etapach montażowych

**Daha sonraki montaj basamaklarında kullanılacak olan, aşağıdaki sembollere lütfen dikkat edin.**

Kérjük, hogy a következő szimbólumokat, melyek az alábbi építési fokokban alkalmazásra kerülnek, vegyétek figyelembe.



Abziehbild in Wasser einweichen und anbringen  
Soak and apply decals  
Mouiller et appliquer les décalcomanies  
Transfer in water even latex wiken en aanbrengen  
Remojar y aplicar las calcomanías  
Pör de molho em água e aplicar o decalque  
Immergere in acqua ed applicare decalcomania  
Blöt och fäst dekalerna  
Kostuta siirtokuvaa vedessä ja aseta paikalleen  
Fukt motivet i varmt vann og færd det over på modellen  
Dypp bildet i vann og sett det på  
Переводную картинку намочить и нанести  
Zmlekczyć kalkomanie w wodzie a następnie nakleić  
Βουτήξτε τη χαλκομανία στο νερό και τοποθετήστε τη  
Çikartmayı suda yumuşatın ve koyun  
Obtisk namočite ve vodě a umístěte  
a matricát vizben beáztatni és felhelyezni  
Preslikač potopiti v vodo in zatem nanašati



Kleben  
Glue  
Coller  
Lijmen  
Engomar  
Colar  
Incollare  
Limmas  
Liimaa  
Limes  
Lim  
Клеить  
Przykleić  
Κόλλημα  
Yapıştırma  
Lepeni  
ragasztani  
Lepiti



Nicht kleben  
Don't glue  
Ne pas coller  
Niet lijmen  
No engomar  
Não colar  
Non incollare  
Limmas ej  
Älä liimaa  
Skal ikke limes  
Ikke lim  
Не клеить  
Nie przyklejać  
ηη κολλάτε  
Yapıştırmayın  
Nelepit  
nem szabad ragasztani  
Ne lepiti



Wahlweise  
Optional  
Facultatif  
Naar keuze  
No engomar  
Alternado  
Facoltativo  
Valfritt  
Vaihtoehtoisesti  
Valgfritt  
Valgfritt  
На выбор  
Do wyboru  
εναλλακτικά  
Szemeli  
Változtethő  
tetészes szerint  
način izibre



Anzahl der Arbeitsgänge  
Number of working steps  
Nombre d'étapes de travail  
Het aantal bouwstappen  
Número de operaciones de trabajo  
Número de etapas de trabalho  
Número di passaggi  
Antal arbetsmoment  
Valfritt  
Työväleiden lukumäärä  
Antali arbeidstrinn  
Antali arbeidstrinn  
На количество операций  
Liczba operacji  
αριθμός των εργασιών  
İş safhalarının sayısı  
Počet pracovných operáci  
a munkafolyamatok száma  
Številka koraka montaže



Entfernen  
Remove  
Détacher  
Verwijderen  
Sacar  
Retirar  
Eliminare  
Tag loss  
Poista  
Fjern  
Fjern  
Удалить  
Usunąć  
απομακρύνετε  
Temizleyin  
Odstranit  
eltávolítani  
Ostraniti



Gleichen Vorgang auf der gegenüberliegenden Seite wiederholen  
Repeat same procedure on opposite side  
Opérer de la même façon sur l'autre face  
Dezelfde handeling herhalen aan de tegenoverliggende kant  
Realizar el mismo procedimiento en el lado opuesto  
Repetir o mesmo procedimento utilizado no lado oposto  
Stessa procedura sul lato opposto  
Upprepa proceduren på motsatta sidan  
Toista sama toimenpide kuten viereisellä sivulla  
Gjenta prosedyren for den motsatte siden  
Gjenta prosedyren på siden tvers overfor  
Повторять такую же операцию на противоположной стороне  
Taki sam przebieg czynności powtórzyc na stronie przeciwnej  
επανάλαβετε την ίδια διαδικασία στην απέναντι πλευρά  
Aynı işlemleri karşı tarafta tekrarlayın  
Ugyanazt a folyamatot a szemben található oldalon megismételni  
Isti postopek ponoviti in na suprotni strani



Abbildung zusammengesetzter Teile  
Illustration of assembled parts  
Figure représentant les pièces assemblées  
Afbelding van samengevoegde onderdelen  
Ilustración piezas ensambladas  
Figura representando peças encaixadas  
Illustrazione delle parti assemblate  
Bildet visar dalarna hopsatta  
Kuva yhteenliitetyistä osista  
Illustrasjonen viser de sammensatte delene  
Illustrasjon, sammensatte deler  
Изображение смонтированных деталей  
Rysunek złożonych części  
απεικόνιση των συναρμολογημένων εξαρτημάτων  
Birleştirilen parçaların şekli  
Zobrazení sestavených dílů  
összeállított alkatrészek ábrája  
Silka slopljenega dela

## Benötigte Farben / Used Colors

Benötigte Farben  
Required coloursPeintures nécessaires  
Benodigde kleurenPinturas necesarias  
Tintas necesariasColori necessari  
Använda färgerTarvittavat värit  
Du trenger følgende färgerNødvendige farger  
Необходимые краскиPotrzebne kolory  
Απαιτούμενα χρώματαGerekli renkler  
Potřebné barvySzükséges színek.  
Potrebne barve**A**

nato-oliv, matt 46

Nato-olive, matt  
olive O.T.A.N., mat  
Nato-oliv, mat  
atelluna Nato, mate  
oliva Nato, fosco  
oliva nato, opaco  
Nato-oliv, matt  
nato olivii, himmeä  
Nato-oliv, mat  
NATO-oliven, matt  
оливковый "НАТО", матовый  
оливк. NATO, матовый  
χακι του NATO, ματ  
nato yeşili, mat  
olivová NATO, matná  
Nato-oliv, matt  
NATO oliva, mat

**B**

bronzegrün, matt 65

bronzee green, matt  
vert bronze, mat  
bronzegroen, mat  
verde bronzee, mate  
verde bronzee, fosco  
verde bronzee, opaco  
bronzegrün, matt  
bronsivihreä, himmeä  
bronzegrün, mat  
bronzegrün, matt  
bronzegrün, matt  
бронзово-зеленый, матовый  
brązowozielony, matowy  
πράσινο μπρούτζου, ματ  
bronz yeşili, mat  
bronzové zelená, matná  
bronzazöld, matt  
bronzazelena, mat

**C**

lederbraun, matt 84

leather brown, matt  
brun cuir, mat  
lederbrun, mat  
marrón cuero, mate  
castanho couro, fosco  
marrone cuoio, opaco  
läderbrun, matt  
nahkonruskea, himmeä  
läderbrun, matt  
läderbrun, matt  
коричневая кожа, матовый  
brunatny jak skóra, matowy  
καφέ δέρματος, ματ  
deri kahverengi, mat  
kožená hnědá, matná  
börbarna, matt  
koža rjava, mat

**D**

teerswarz, matt 6

tar black, matt  
noir tarte, mat  
teerzwart, mat  
negro alquitrán, mate  
alcitrão, fosco  
nero catrame, opaco  
asfaltsvart, matt  
terävynusta, himmeä  
tjæresort, mat  
tjæresort, matt  
смолисто-черный, матовый  
czarny-smola, matowy  
μαύρο πίσος, ματ  
dehtové černá, matná  
kátrányfekete, matt  
ter črna, mat

**E**

silber, metallic 90

silver, metallic  
argent, métallique  
zilver, metallic  
plata, metalizado  
argento, metallico  
silver, metallic  
hopea, metallikiilto  
savv, metallak  
savv, metallic  
серебрястый, металл  
srebrny, metaliczny  
σημη, μεταλλικό  
stříbrná, metaliza  
ezüst, metáli  
srebrna, metalik

**F**

orange, glänzend 30

orange, gloss  
orange, brillant  
orange, glansend  
naranja, brillante  
laranja, brilhante  
arancione, lucente  
orange, blank  
oranssi, kiiltävä  
orange, skinnende  
orange, blank  
оранжевый, блестящий  
pomarańczowy, błyszczący  
πορτοκαλί, γυαλιστερό  
portakal, parlak  
oranzová, lesklá  
narancsszínú, fényes  
pomorandžast, bleskajoča

**G**

feuerrot, glänzend 31

fiery red, gloss  
rouge feu, brillant  
rood helder, glansend  
rojo fuego, brillante  
vermelho vivo, brilhante  
rosso fuoco, lucente  
eldröd, blank  
tulipunainen, kiiltävä  
ildrod, skinnende  
ildrod, blank  
огненно-красный, блестящий  
szarony ognisty, błyszczący  
κόκκινο φωτιάς, γυαλιστερό  
ateş kırmızısı, parlak  
ohnivě červená, lesklá  
tűzpiros, fényes  
ogjenj rdeča, bleskajoča

**H**

sand, matt 16

sandy yellow, matt  
couleur de sable, mat  
zandkleur, mat  
arena, mate  
areia, fosco  
sabbia, opaco  
sand, matt  
hiekkä, himmeä  
sand, mat  
sand, matt  
песчаный, матовый  
piaskowy, matowy  
χρώμα άμμου, ματ  
kum rengi, mat  
písková, matná  
homokszínű, matt  
pesek, mat

50%

rost, matt 83

rust, matt  
rouille, mat  
roest, mat  
orin, mate  
ferrogem, fosco  
color ruggine, opaco  
rust, matt  
ruske, himmeä  
rust, mat  
rust, matt  
ржавина, матовый  
rdzawy, matowy  
χρώμα σκουριάς, ματ  
pas rengi, mat  
rezavá, matná  
rozsdá, matt  
rjava, mat

**I**

50%

eisen, metallic 91

steel, metallic  
coloris fer, métallique  
ijzerkleurig, metallic  
ferroso, metalizado  
ferro, metallico  
ferro, metallico  
järnfärg, metallic  
teräksenväriinen, metallikiilto  
jern, metallak  
jern, metallic  
стальной, металл  
želazno, metaliczny  
σιδηρού, μεταλλικό  
demir, metalik  
železná, metaliza  
vas, metáli  
železna, metalik

50%

braun, matt 85

brown, matt  
brun, mat  
bruin, mat  
marrón, mate  
castanho, fosco  
marrone, opaco  
brun, matt  
ruskea, himmeä  
brun, mat  
brun, matt  
коричневый, матовый  
brązowy, matowy  
καφέ, ματ  
kahverengi, mat  
hnědá, matná  
barna, matt  
rjava, mat

**J**

50%

sand, matt 16

sandy yellow, matt  
couleur de sable, mat  
zandkleur, mat  
arena, mate  
areia, fosco  
sabbia, opaco  
sand, matt  
hiekkä, himmeä  
sand, mat  
sand, matt  
песчаный, матовый  
piaskowy, matowy  
χρώμα άμμου, ματ  
kum rengi, mat  
písková, matná  
homokszínű, matt  
pesek, mat

70%

schwarz, seidenmatt 302

black, silky-matt  
noir, satiné mat  
zwart, zijdemat  
negro, mate seda  
preto, fosco sedoso  
nero, opaco sata  
svart, seidenmatt  
musta, silkkihimmeä  
sort, silkematt  
черный, шелковисто-матовый  
czarny, jedwabisto-matowy  
μαύρο, μεταξωτό ματ  
siyah, ipek mat  
černá, hedvábně matná  
fekete, selyemmatt  
črna, svila mat

**K**

30%

eisen, metallic 91

steel, metallic  
coloris fer, métallique  
ijzerkleurig, metallic  
ferroso, metalizado  
ferro, metallico  
ferro, metallico  
järnfärg, metallic  
teräksenväriinen, metallikiilto  
jern, metallak  
jern, metallic  
стальной, металл  
želazno, metaliczny  
σιδηρού, μεταλλικό  
demir, metalik  
železná, metaliza  
vas, metáli  
železna, metalik

**L**

messing, metallic 92

brass, metallic  
laiton, métallique  
messing, metallic  
látón, metalizado  
latão, metallico  
ottone, metallico  
mässing, metallic  
messinki, metallikiilto  
messing, metallak  
messing, metallic  
латунный, металл  
mosiądz, metaliczny  
ορείχαλκου, μεταλλικό  
pirinc, metalik  
mosazná, metaliza  
sárgaréz, metáli  
mesing, metalik

**M**

eisen, metallic 91

steel, metallic  
coloris fer, métallique  
ijzerkleurig, metallic  
ferroso, metalizado  
ferro, metallico  
ferro, metallico  
järnfärg, metallic  
teräksenväriinen, metallikiilto  
jern, metallak  
jern, metallic  
стальной, металл  
želazno, metaliczny  
σιδηρού, μεταλλικό  
demir, metalik  
železná, metaliza  
vas, metáli  
železna, metalik

**N**

weiß, matt 5

white, matt  
blanc, mat  
wit, mat  
bianco, mate  
branco, fosco  
bianco, opaco  
vit, matt  
valkoinen, himmeä  
hvít, mat  
hvít, matt  
белый, матовый  
biały, matowy  
λευκό, ματ  
beyaz, mat  
bielá, matná  
fehér, matt  
bela, mat

1.

orange, glänzend 30

orange, gloss  
orange, brillant  
orange, glansend  
naranja, brillante  
laranja, brilhante  
arancione, lucente  
orange, blank  
oranssi, kiiltävä  
orange, skinnende  
orange, blank  
оранжевый, блестящий  
pomarańczowy, błyszczący  
πορτοκαλί, γυαλιστερό  
portakal, parlak  
oranzová, lesklá  
narancsszínú, fényes  
pomorandžast, bleskajoča

**O**

2.

farblos, matt 2

clear, matt  
incoloro, mat  
kleurloos, mat  
incoloro, mate  
incolor, fosco  
trasparente, opaco  
färglös, matt  
värilös, himmeä  
farveløs, mat  
klar, matt  
бесцветный, матовый  
bezbavny, matowy  
άχρωμο, ματ  
renksiz, matt  
bezbarevná, matná  
szintelen, matt  
brezbarvna, mat

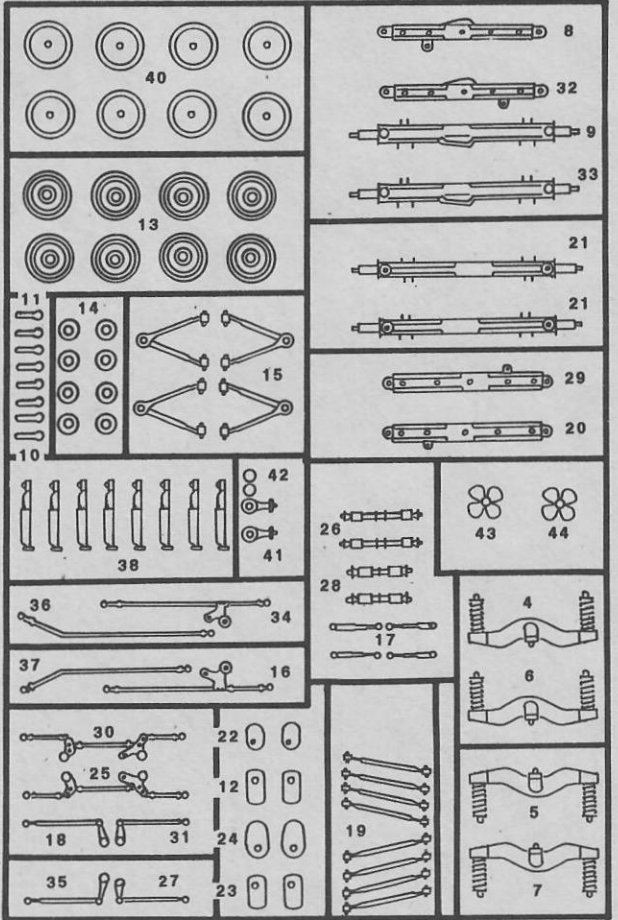
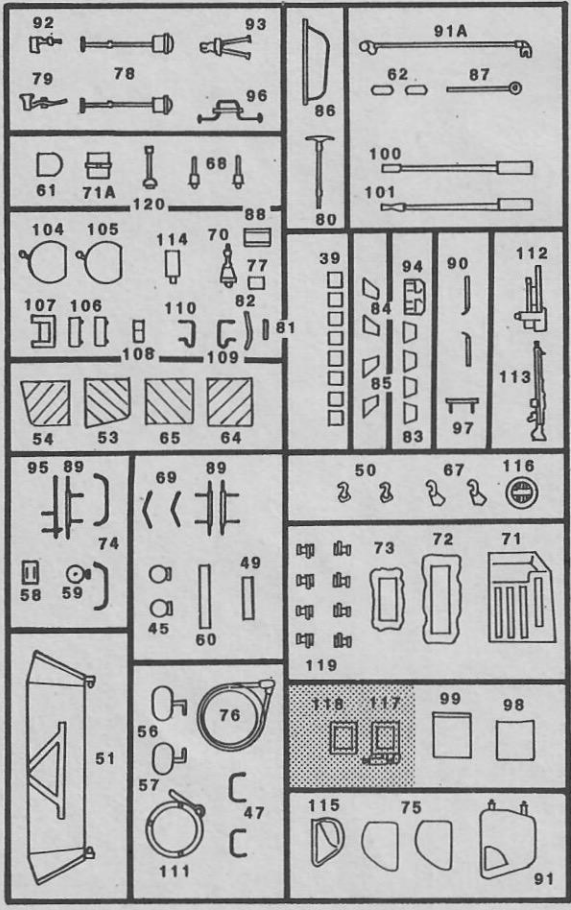
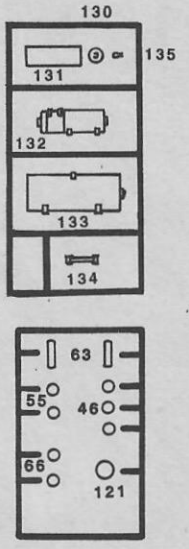
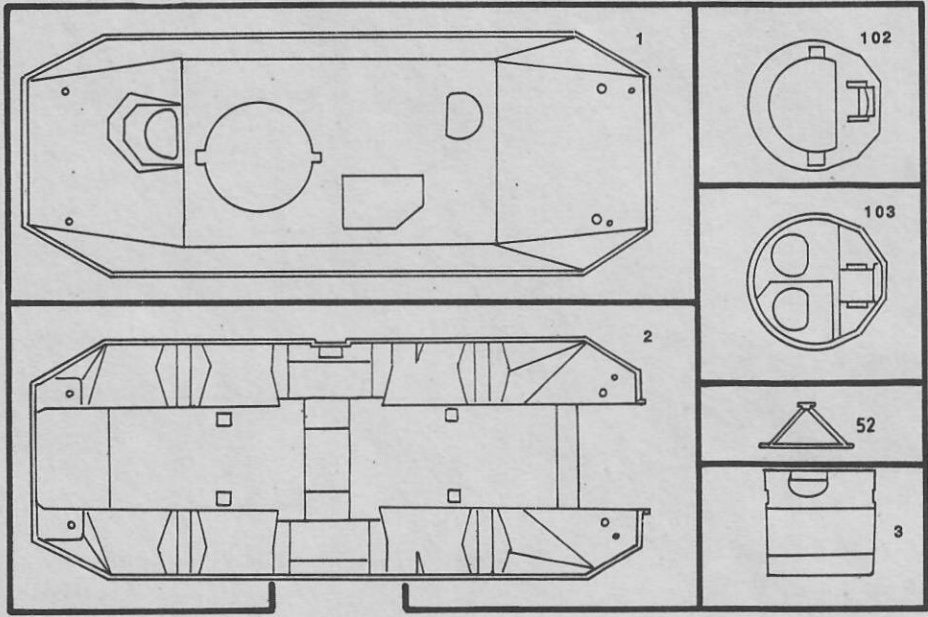

# 1

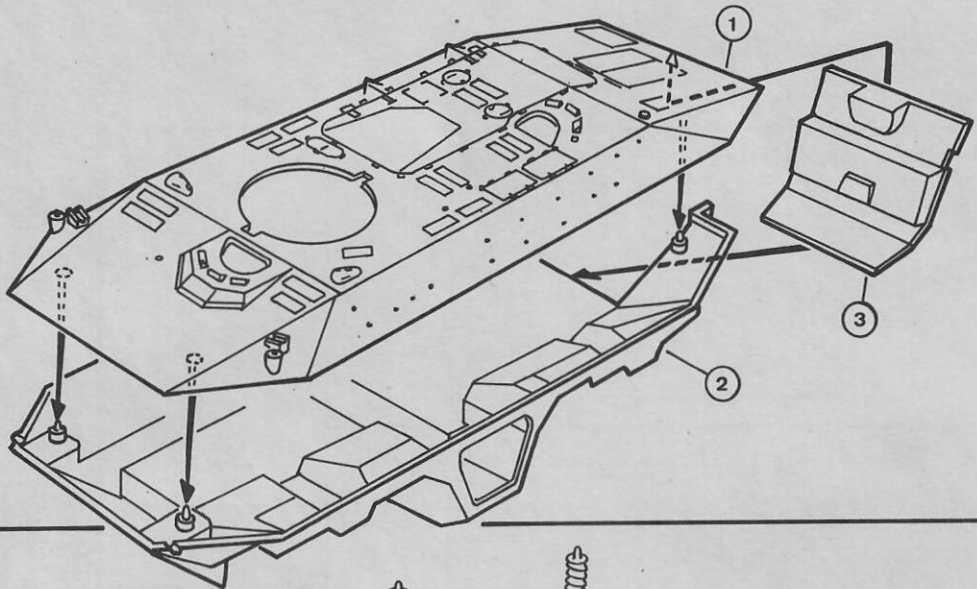

# 2

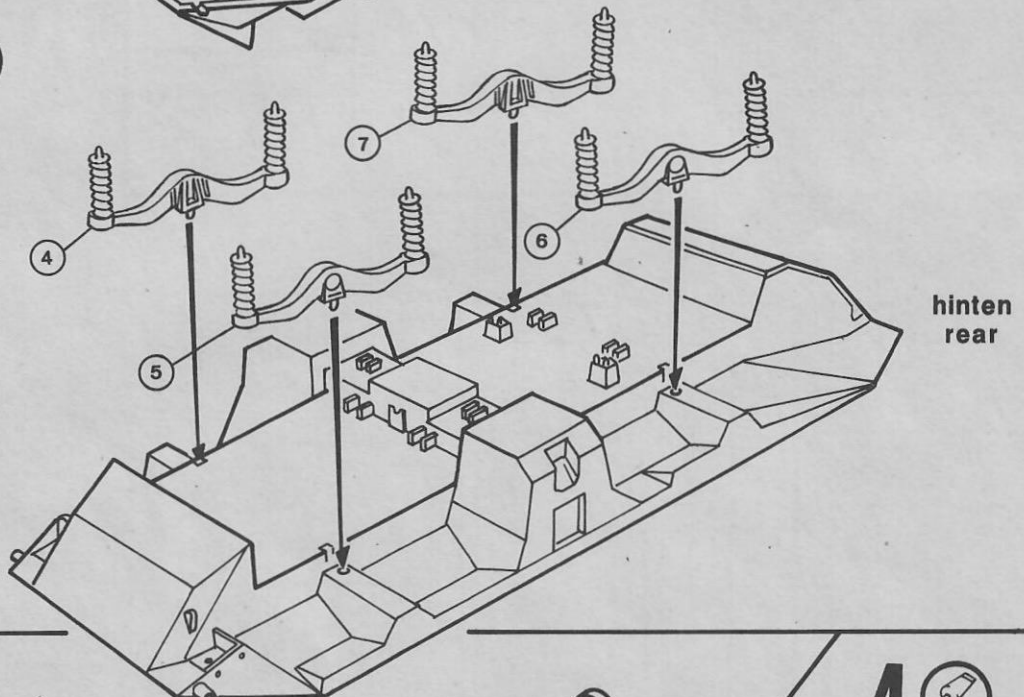

# 3

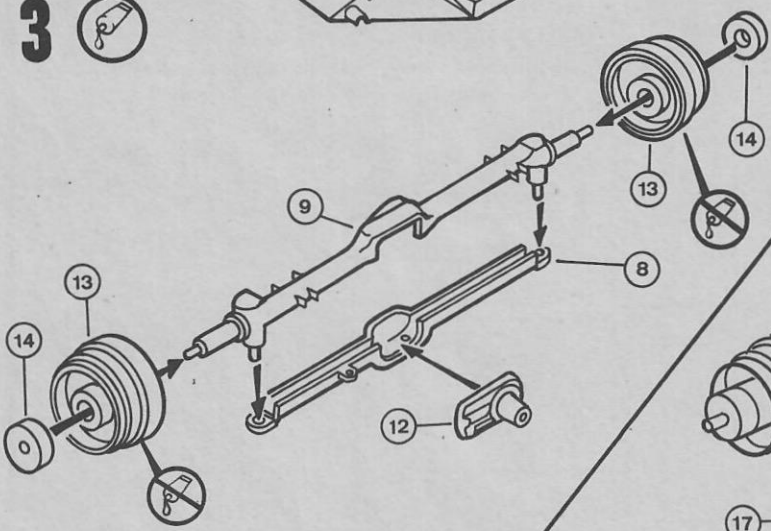

# 4

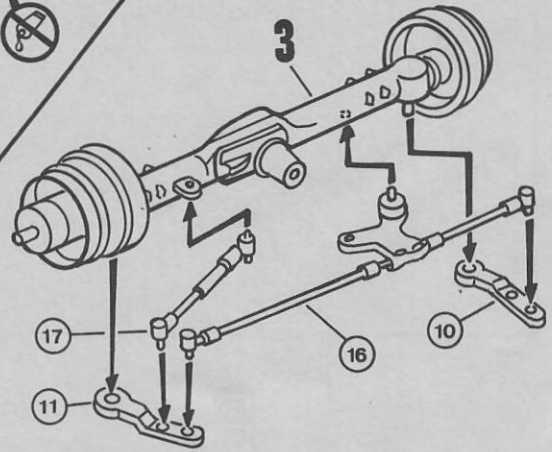

5 

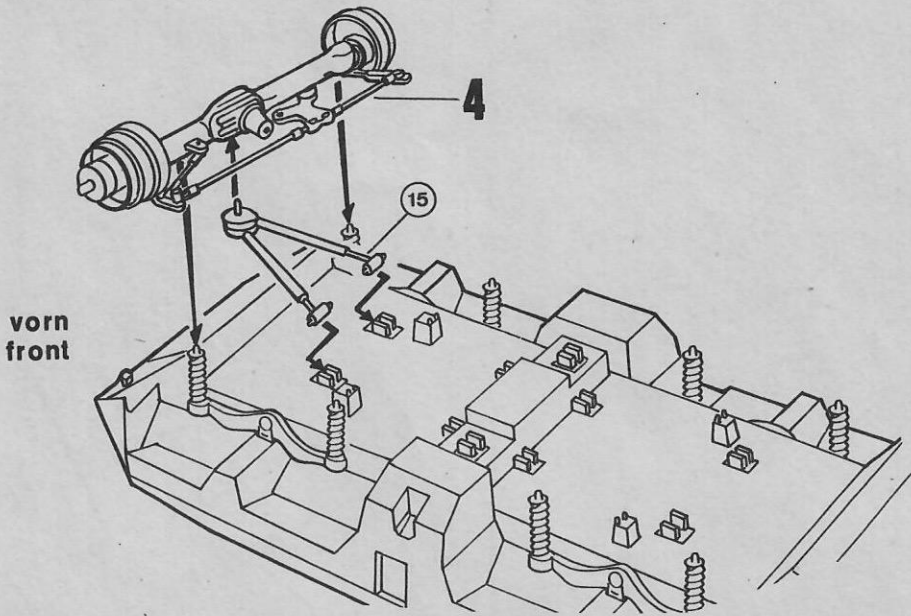

6 

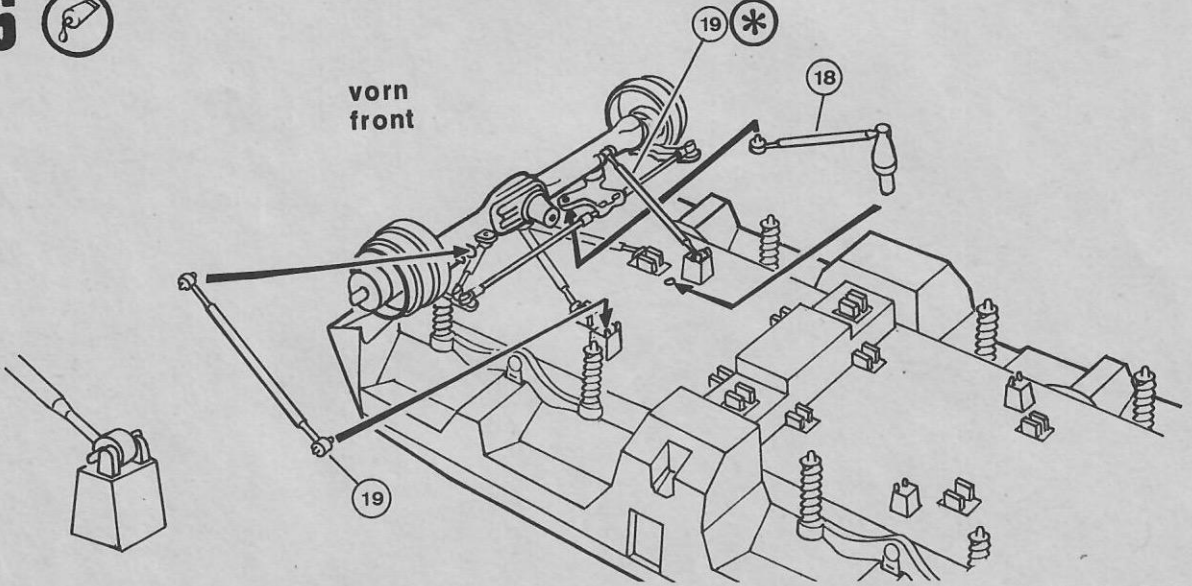

7 

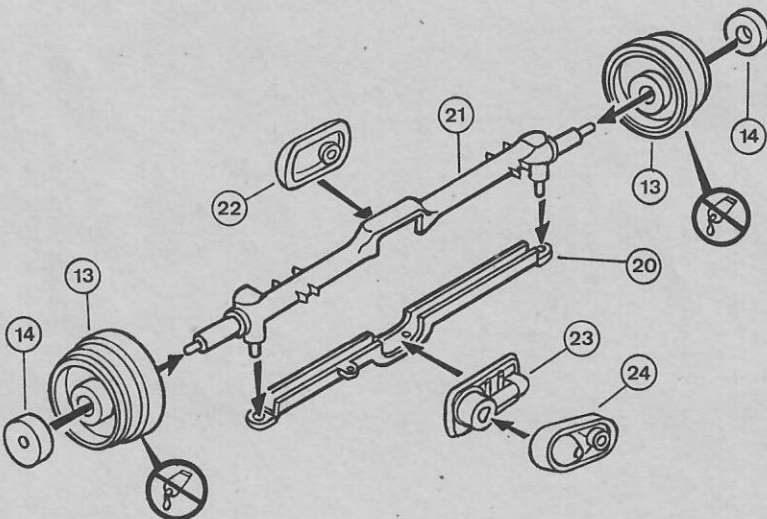

8 

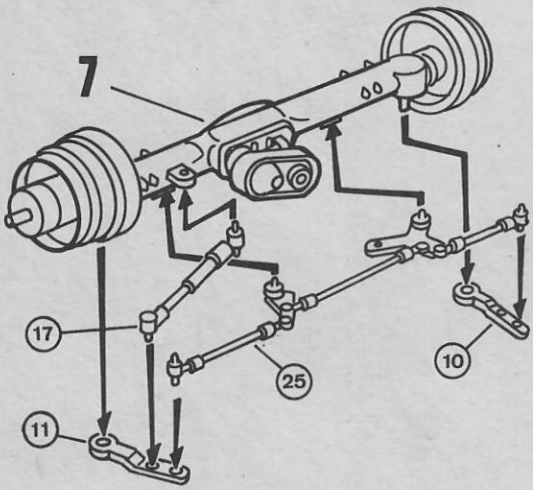

9 

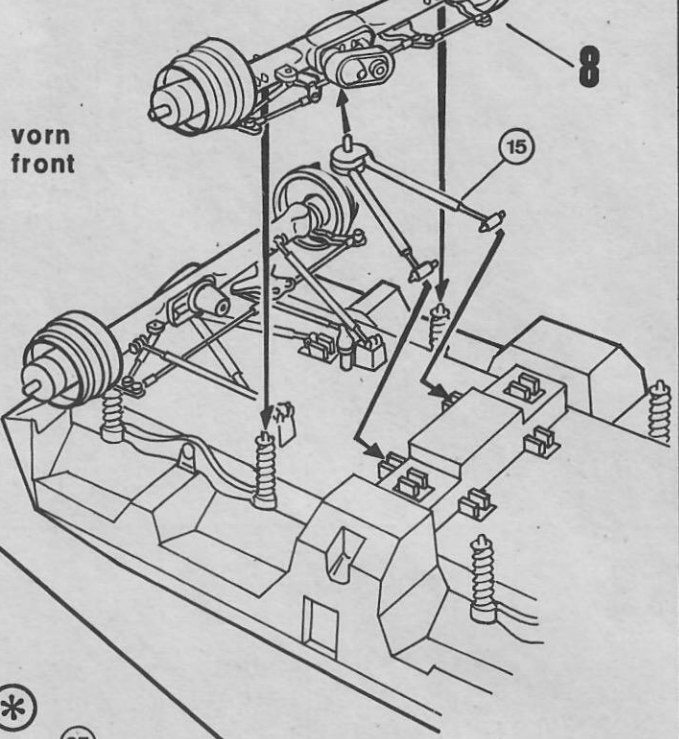

10 

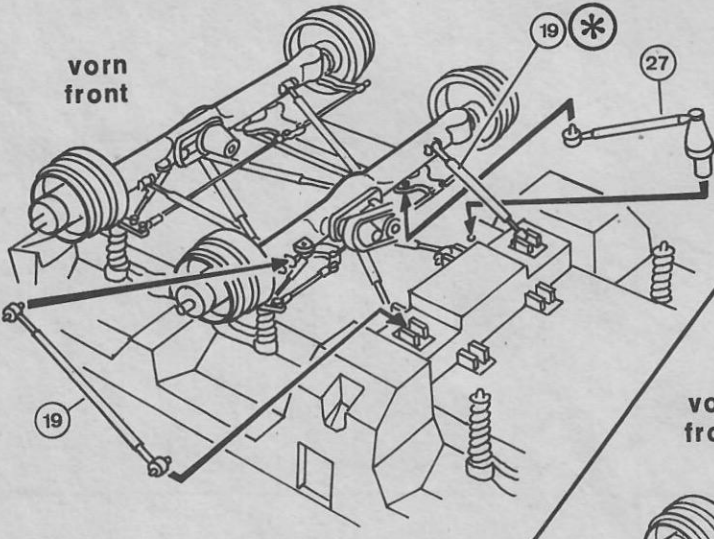

11 

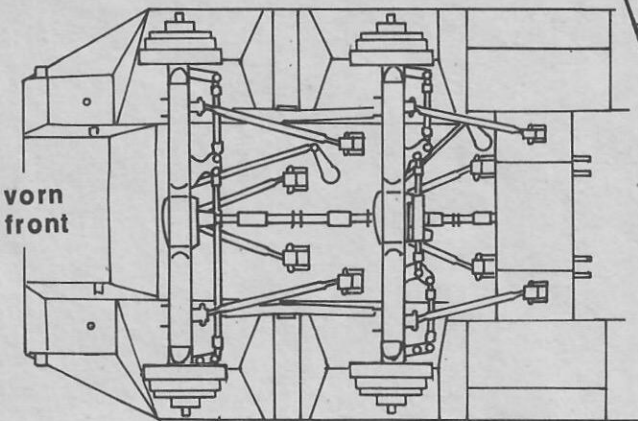
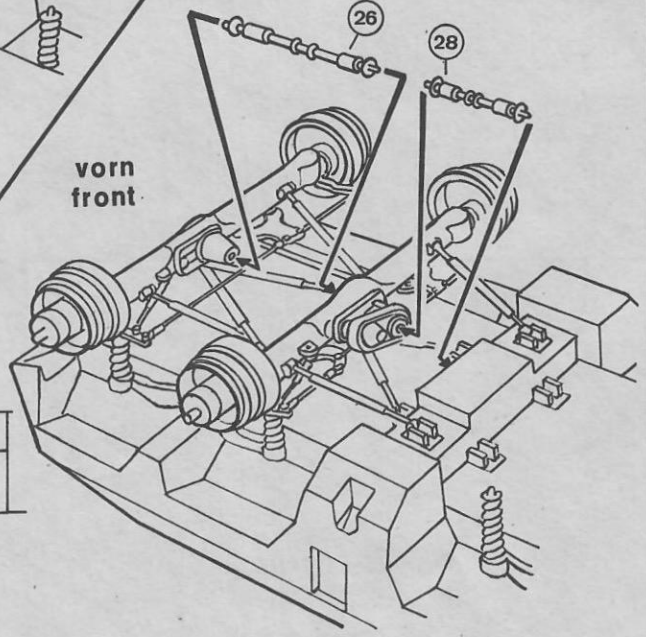

# 12

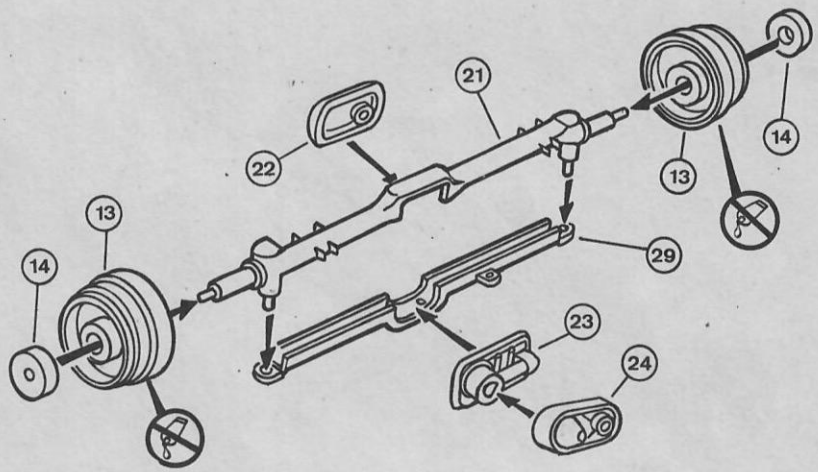

# 13

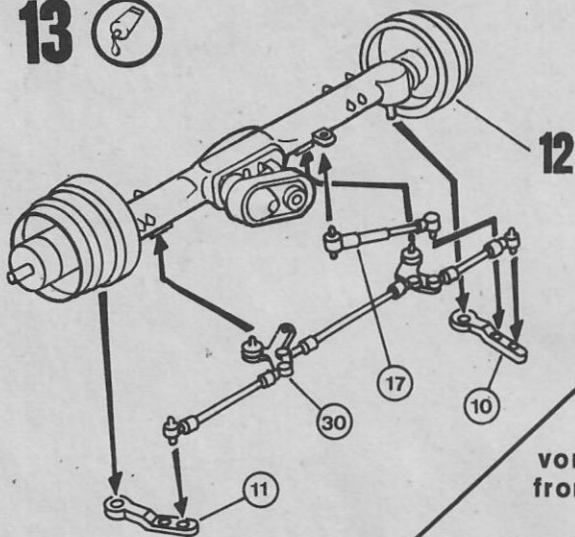

# 14

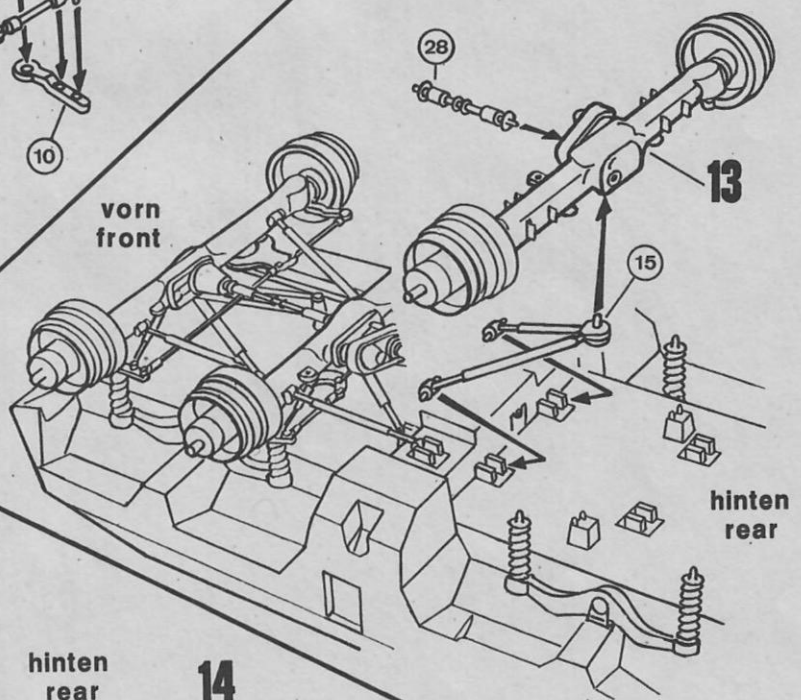

# 15

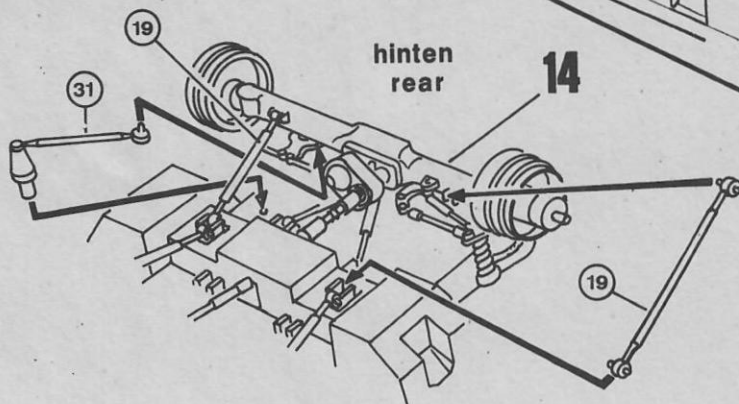



# 16

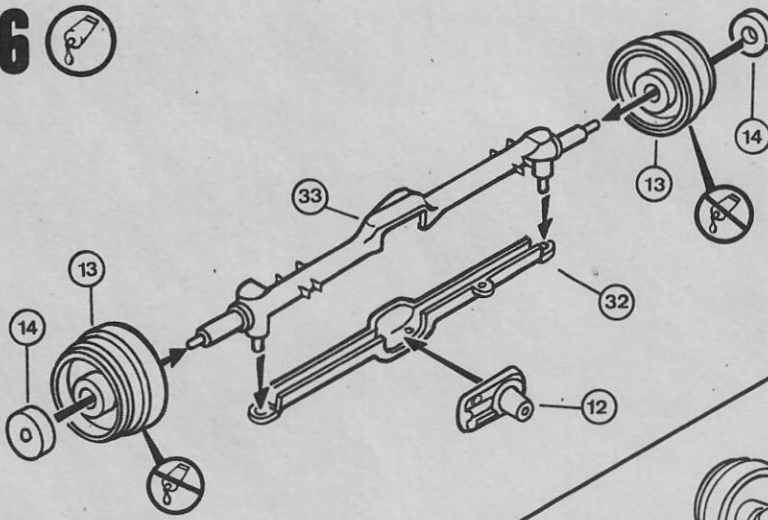

# 17

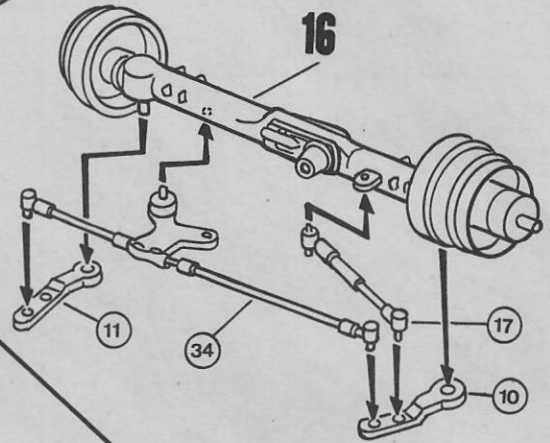

# 18

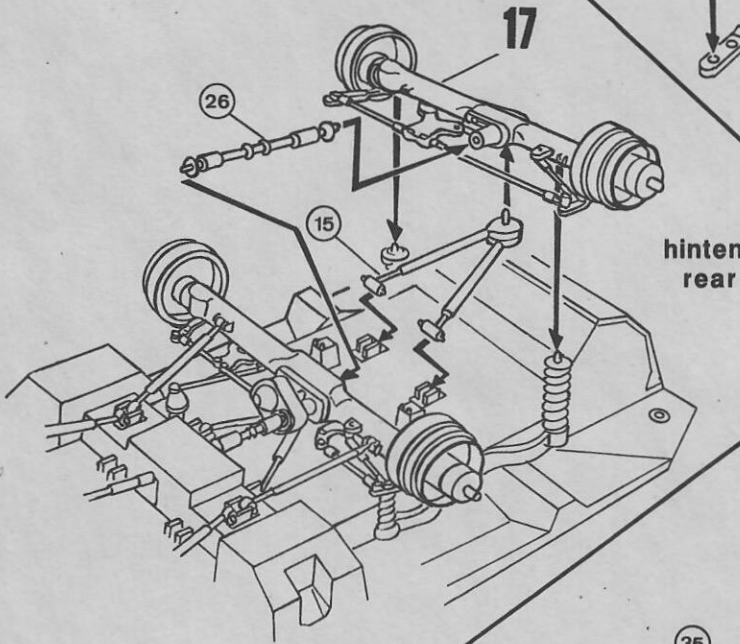

# 19

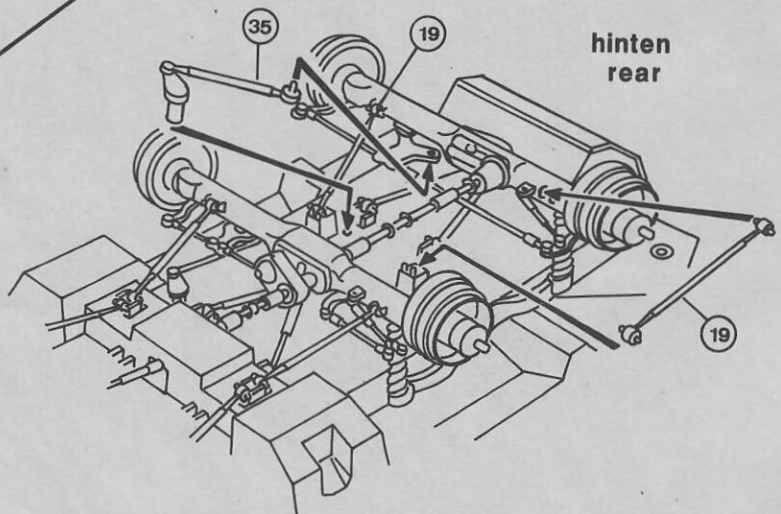

20  

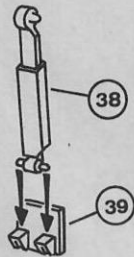

21  

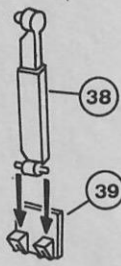

22 

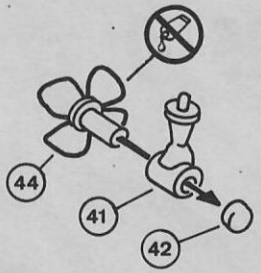

23 

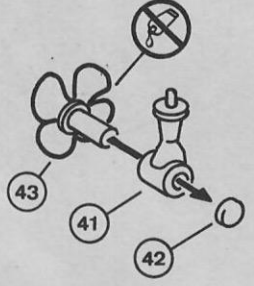

24 

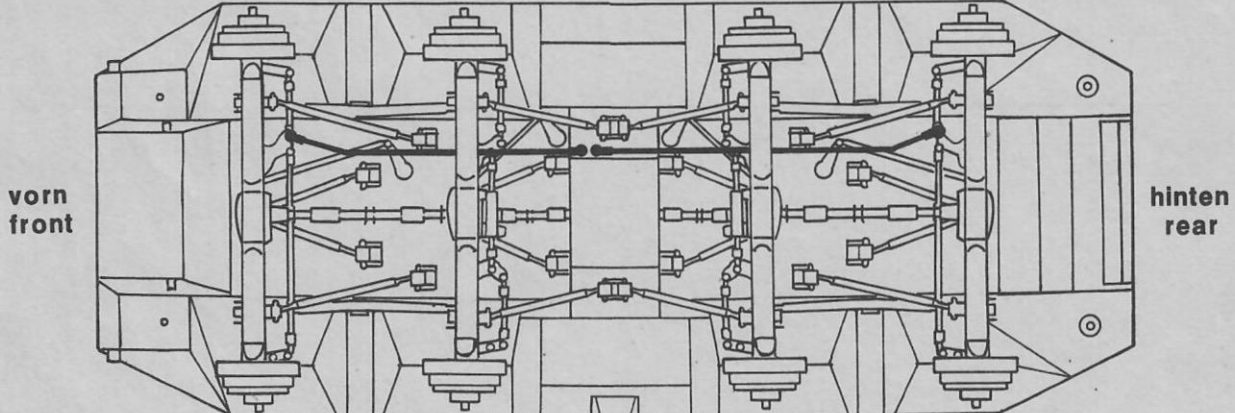
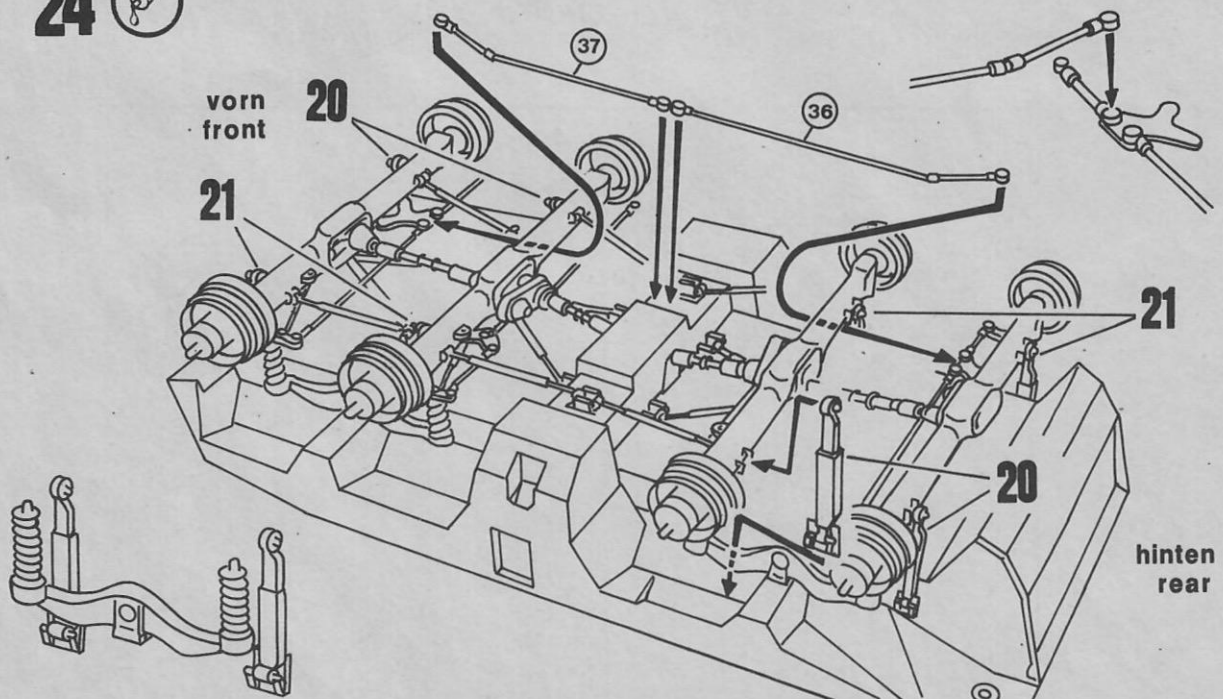

25  8x

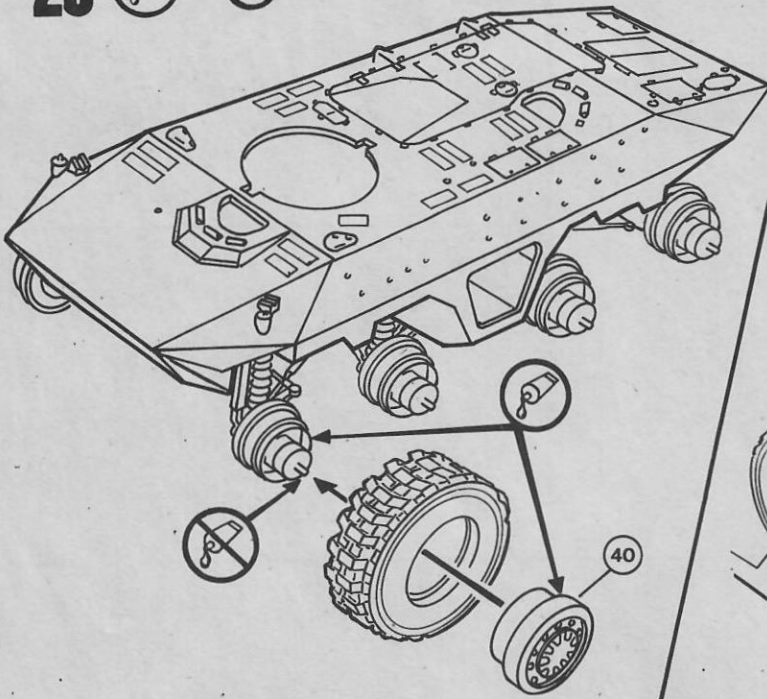

26 

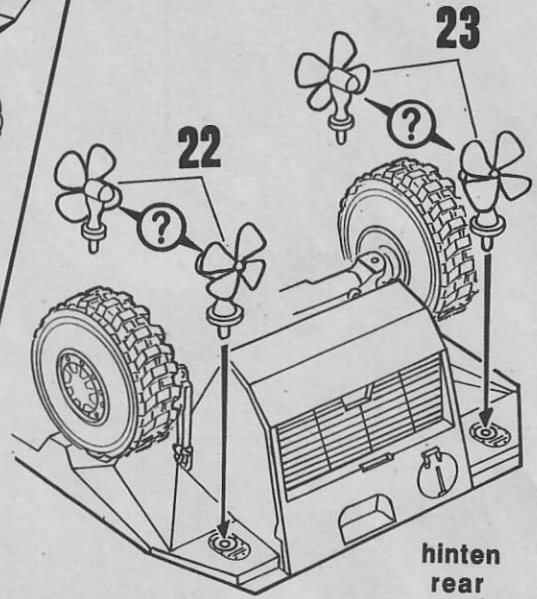

27 

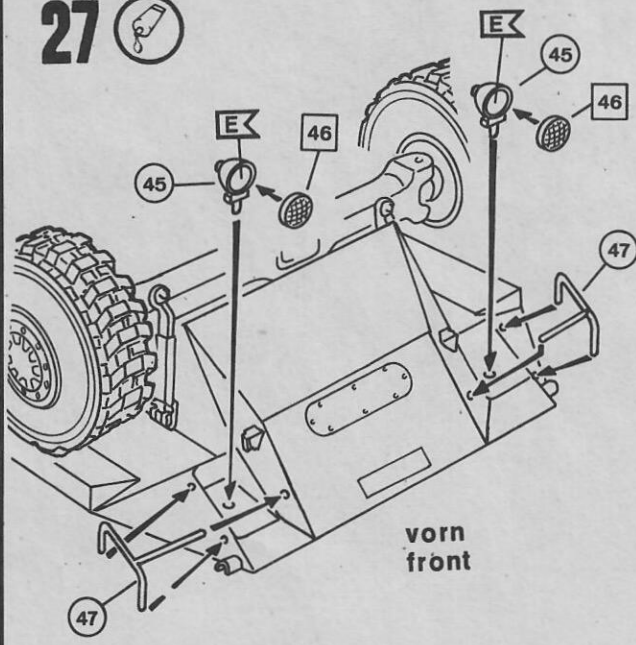

28 

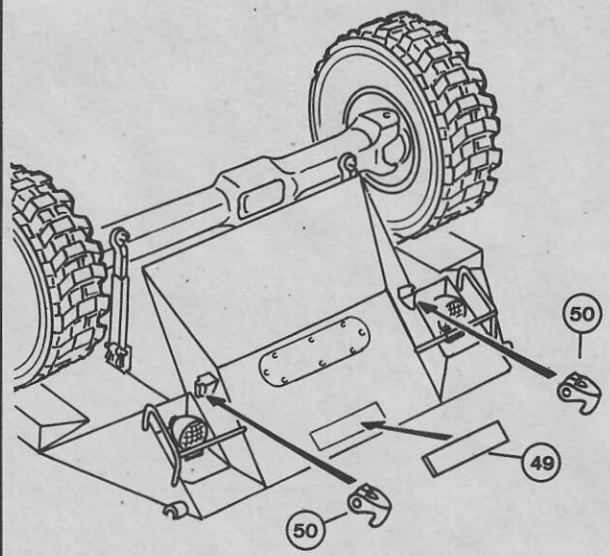

29 

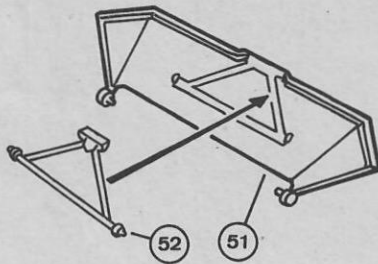

# 30

SY+907 8796	SY+907 8796	SY+802 8801	SY+739 0995
SY+907 8796	SY+907 8796	SY+802 8801	SY+739 0995
SY+802 8801	SY+802 8801	SY+802 8801	SY+802 8801
SY+802 8801	SY+802 8801	SY+802 8801	SY+802 8801
SY+802 8801	SY+802 8801	SY+802 8801	SY+802 8801
SY+802 8801	SY+802 8801	SY+802 8801	SY+802 8801
SY+802 8801	SY+802 8801	SY+802 8801	SY+802 8801
SY+802 8801	SY+802 8801	SY+802 8801	SY+802 8801
SY+802 8801	SY+802 8801	SY+802 8801	SY+802 8801
SY+802 8801	SY+802 8801	SY+802 8801	SY+802 8801

Spitz Luchte A2 SFOR  
Printed in Germany by Hilti AG, 35121 Sprockhövel  
03040-0240

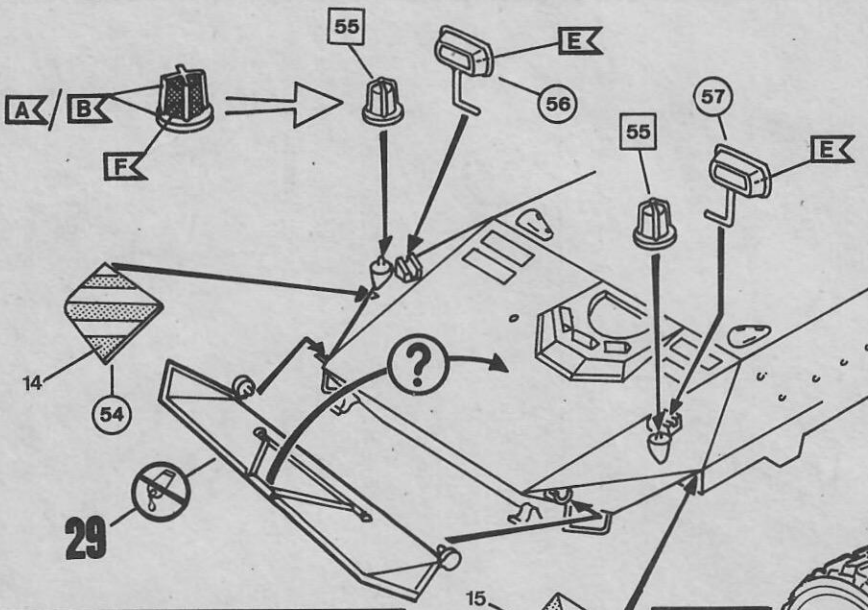

# 31

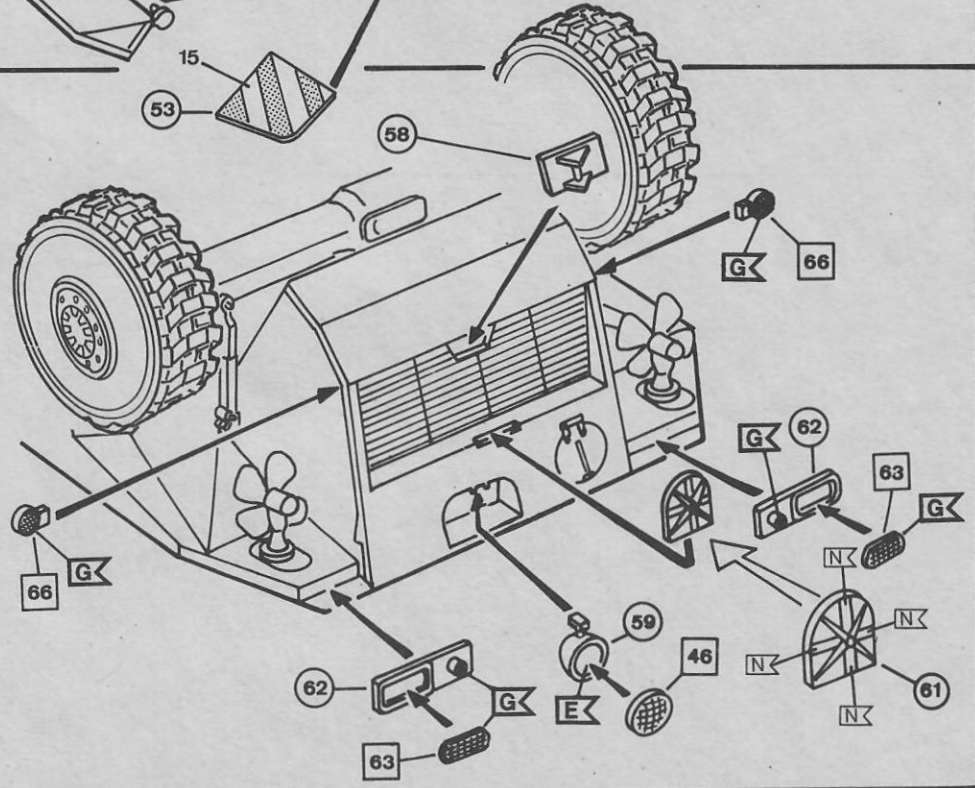

# 32

SY+907 8796	SY+802 8801	SY+739 0995
SY+907 8796	SY+802 8801	SY+739 0995
SY+802 8801	SY+802 8801	SY+802 8801
SY+802 8801	SY+802 8801	SY+802 8801
SY+802 8801	SY+802 8801	SY+802 8801
SY+802 8801	SY+802 8801	SY+802 8801
SY+802 8801	SY+802 8801	SY+802 8801
SY+802 8801	SY+802 8801	SY+802 8801
SY+802 8801	SY+802 8801	SY+802 8801
SY+802 8801	SY+802 8801	SY+802 8801

Spitz Luchte A2 SFOR  
Printed in Germany by Hilti AG, 35121 Sprockhövel  
03040-0240

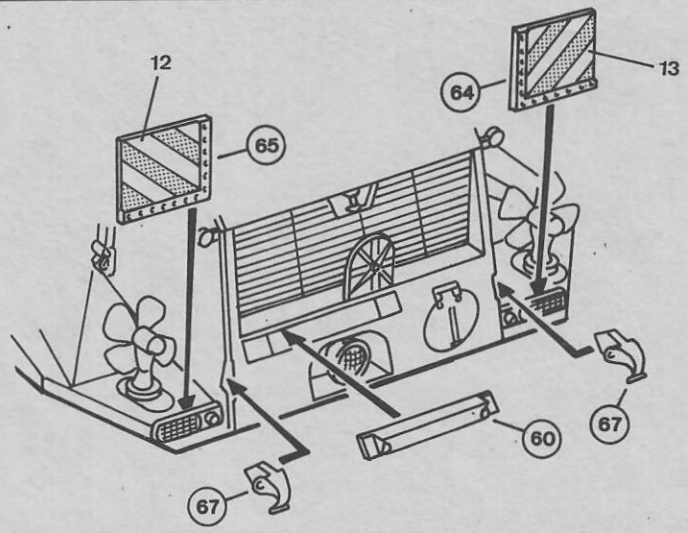

# 33

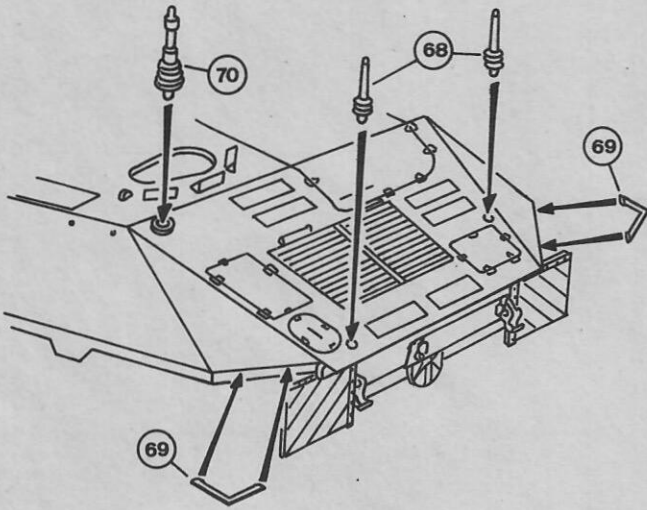

# 34

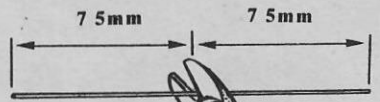

(2X)

## 1

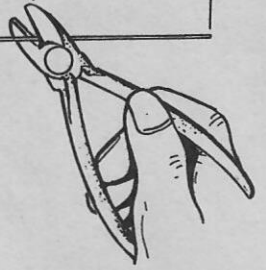

## 2



## 3

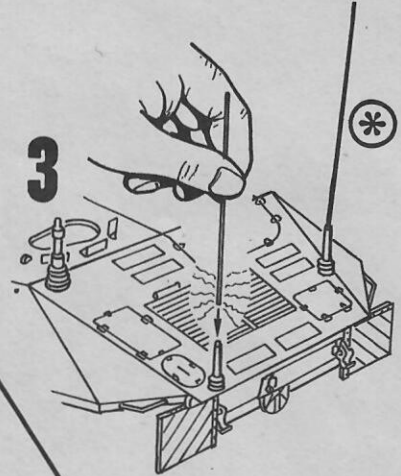

# 35

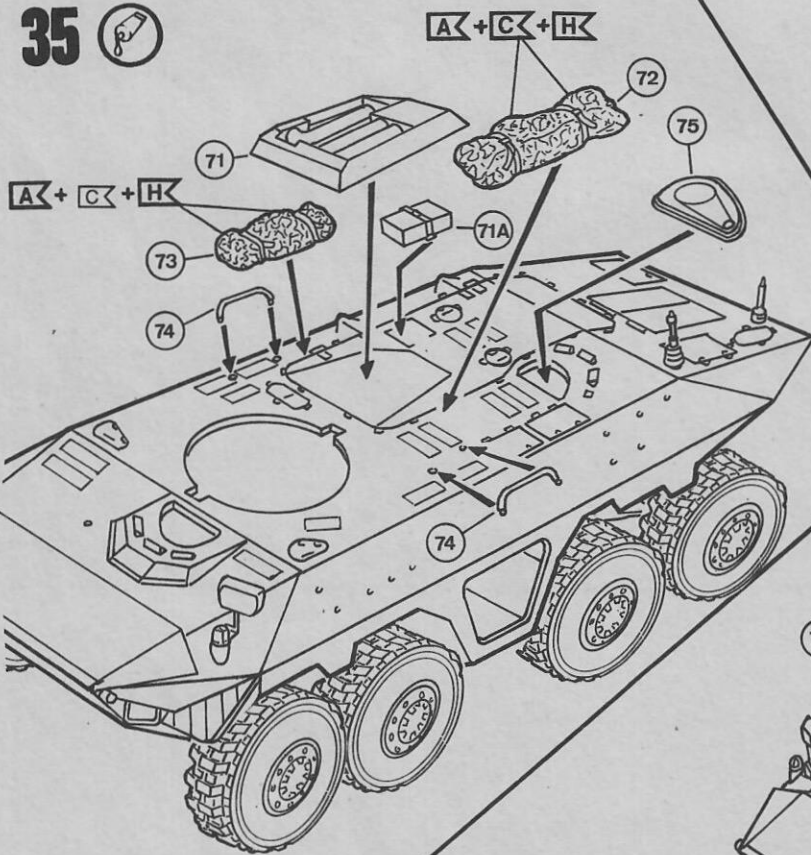

# 36

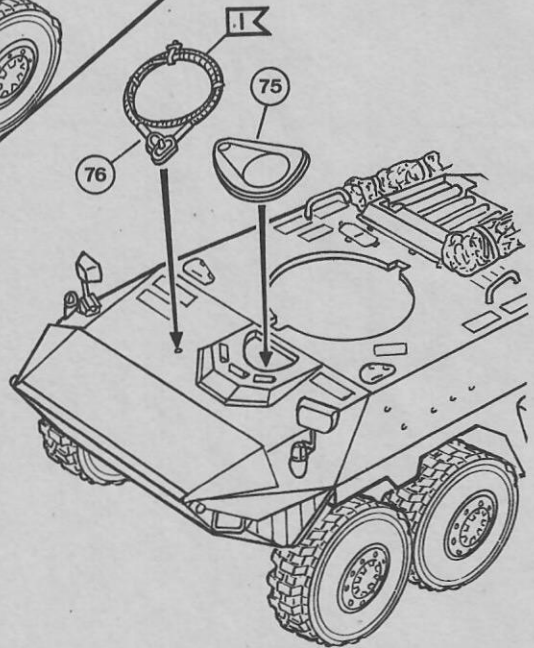

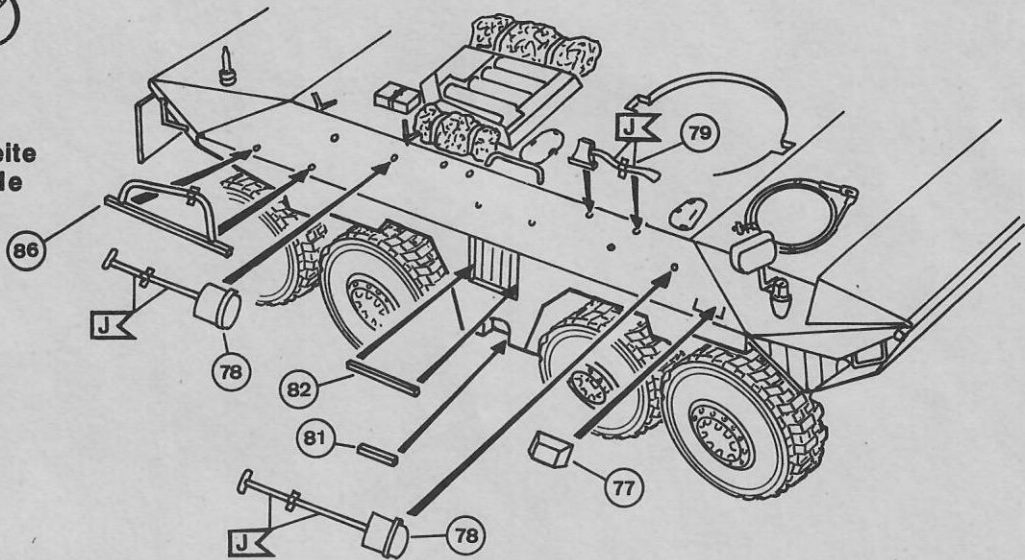
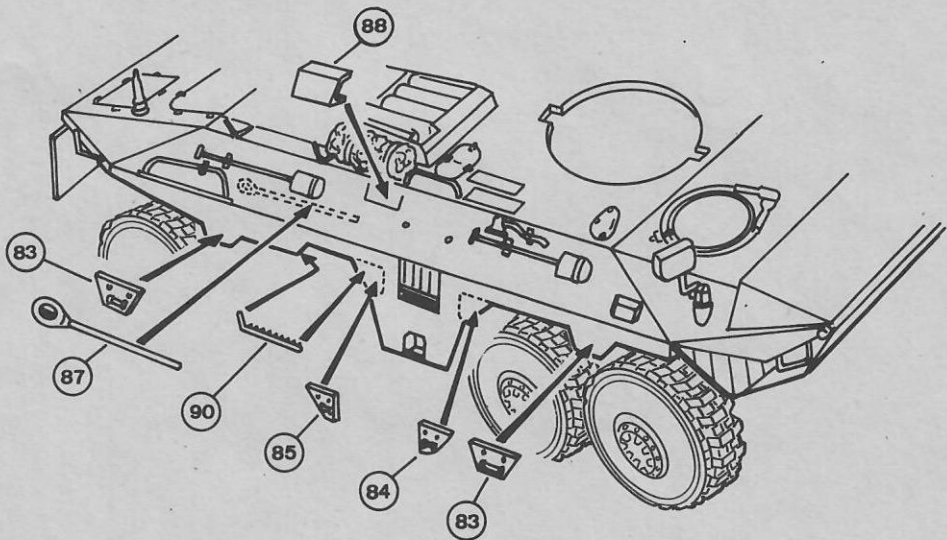
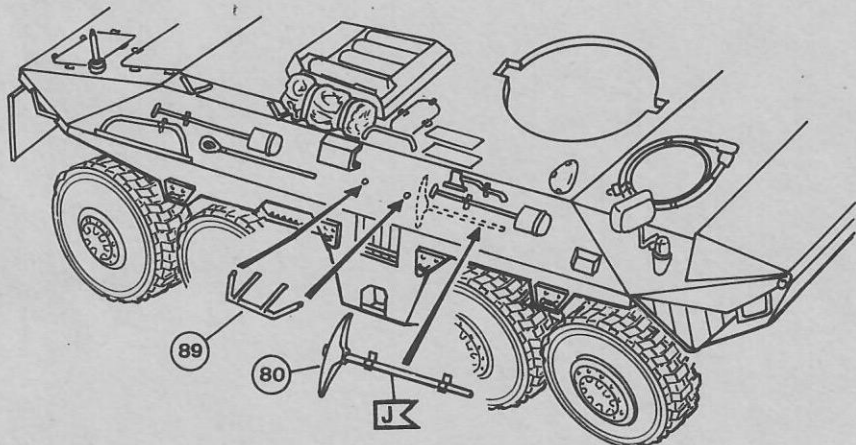
37 rechte Seite  
right side38 rechte Seite  
right side39 rechte Seite  
right side

# 40

linke Seite  
left side

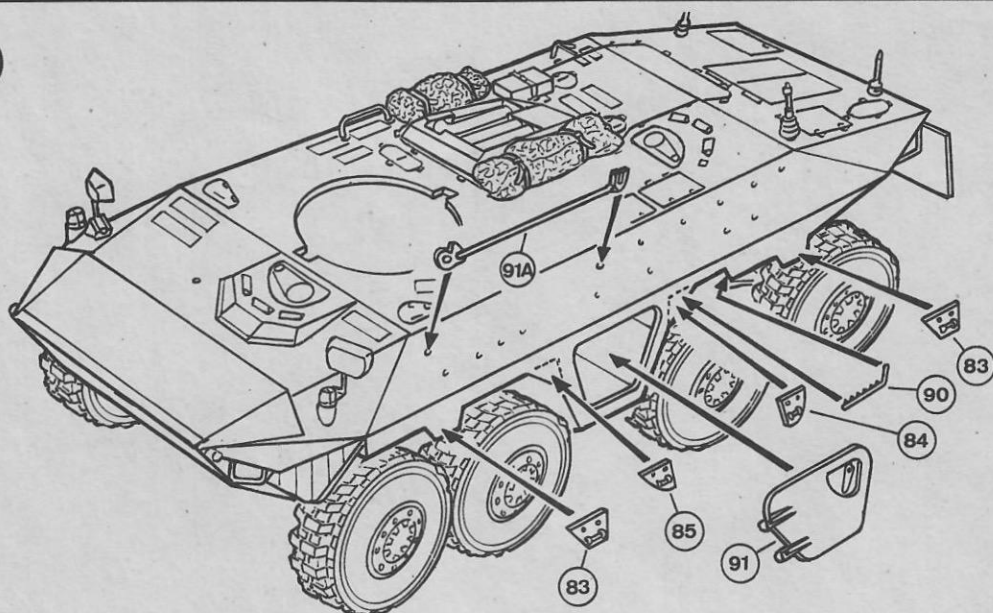

# 41

linke Seite  
left side

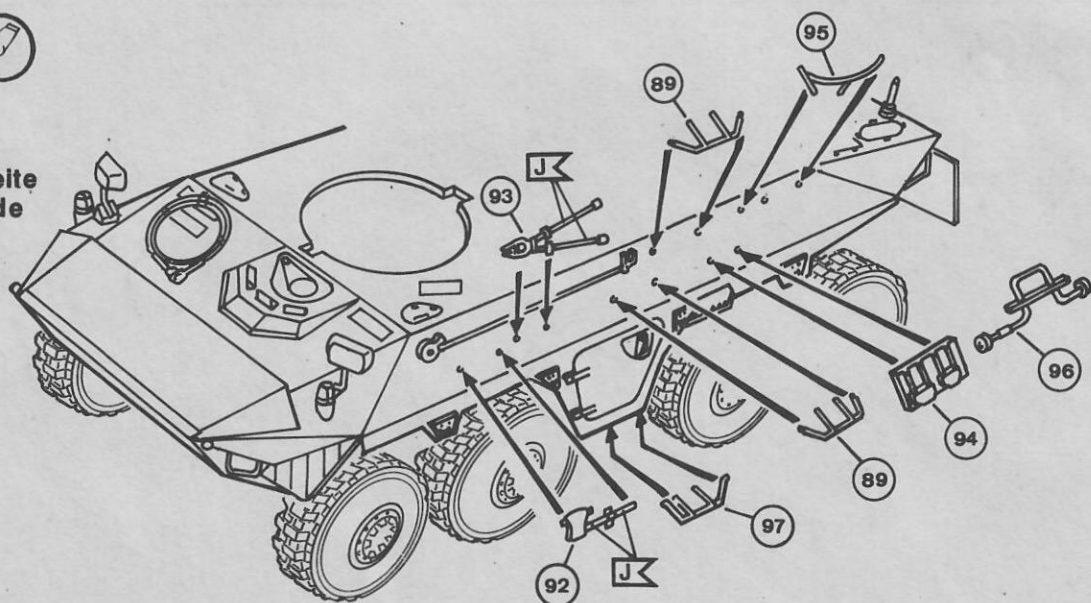

# 42

49/50

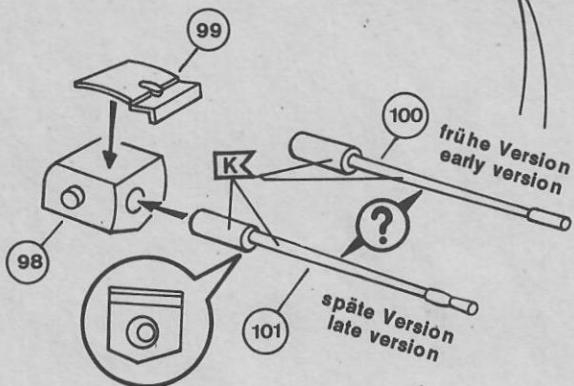

# 43

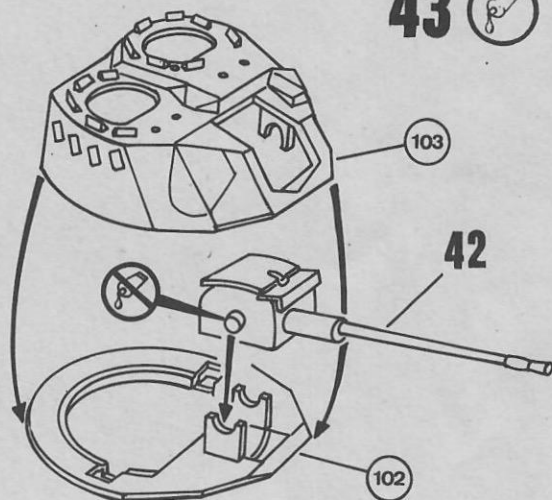

# 44

frühe Version  
early version

49/50

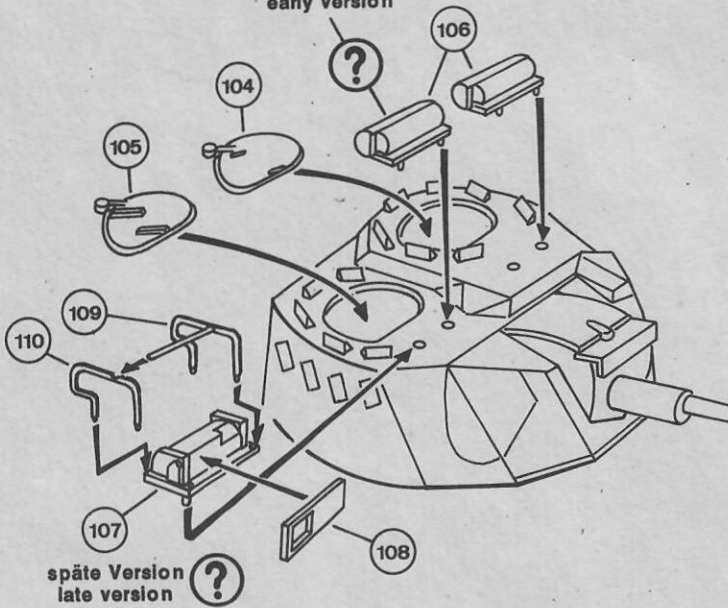

# 45

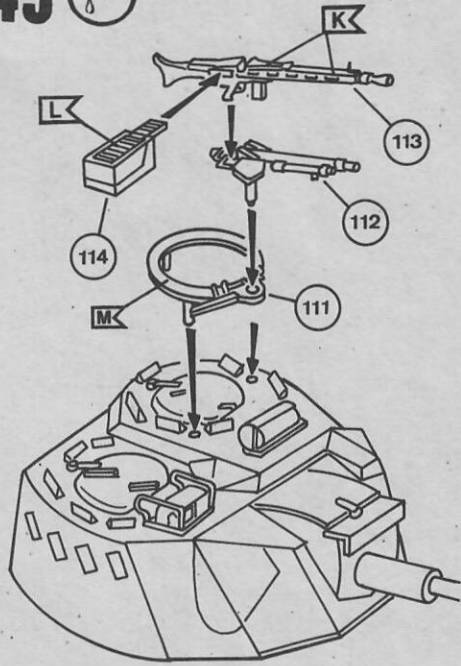

# 46

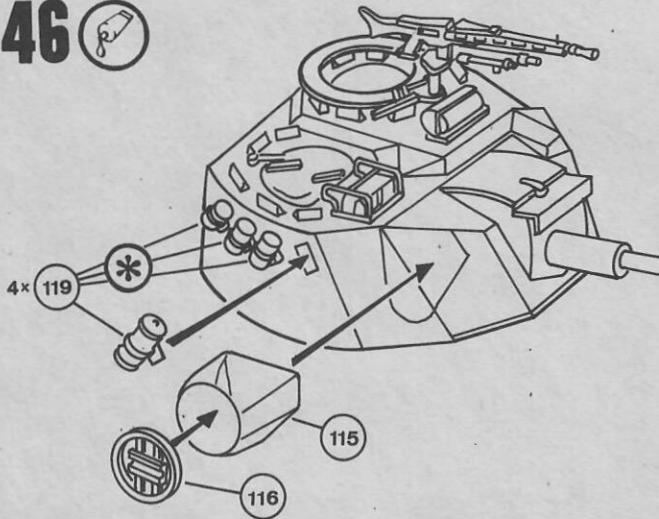

# 48

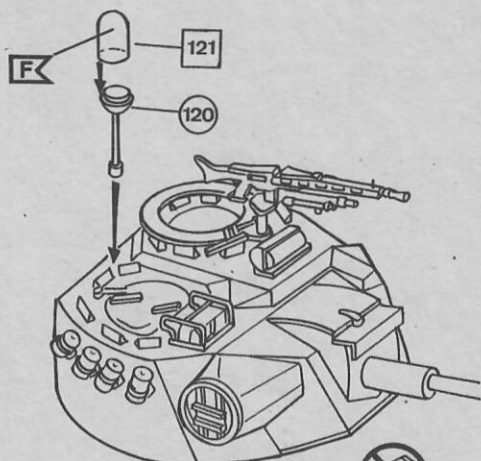

# 47

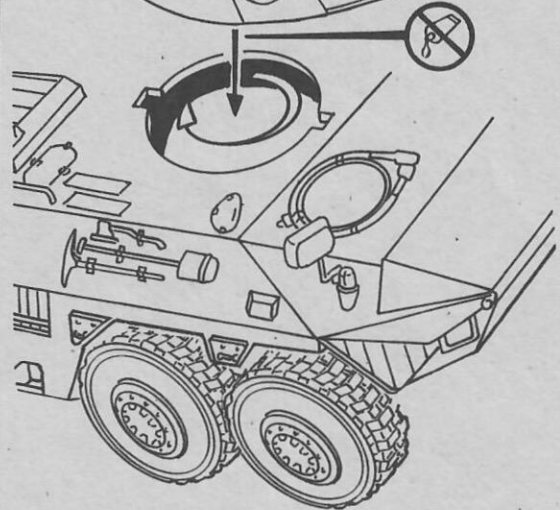
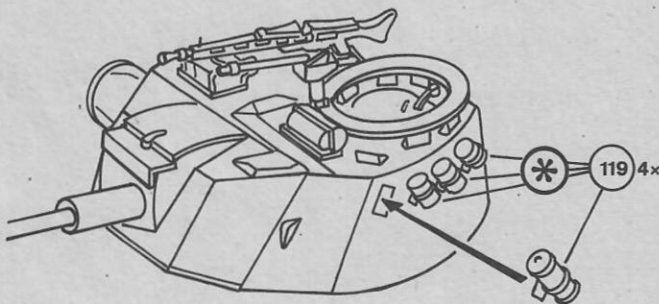



# 49 ?

## 5. gepanzerter Einsatzverband GECON SFOR, Rajlovac, 1998

BY-642 800	BY-644 800	BY-739 910
BY-642 810	BY-644 810	BY-739 920
BY-642 820	BY-644 820	BY-739 930
BY-642 830	BY-644 830	BY-739 940
BY-642 840	BY-644 840	BY-739 950
BY-642 850	BY-644 850	BY-739 960
BY-642 860	BY-644 860	BY-739 970
BY-642 870	BY-644 870	BY-739 980
BY-642 880	BY-644 880	BY-739 990
BY-642 890	BY-644 890	BY-739 1000

BY-642 800 BY-644 800 BY-739 910  
BY-642 810 BY-644 810 BY-739 920  
BY-642 820 BY-644 820 BY-739 930  
BY-642 830 BY-644 830 BY-739 940  
BY-642 840 BY-644 840 BY-739 950  
BY-642 850 BY-644 850 BY-739 960  
BY-642 860 BY-644 860 BY-739 970  
BY-642 870 BY-644 870 BY-739 980  
BY-642 880 BY-644 880 BY-739 990  
BY-642 890 BY-644 890 BY-739 1000

03040-0240

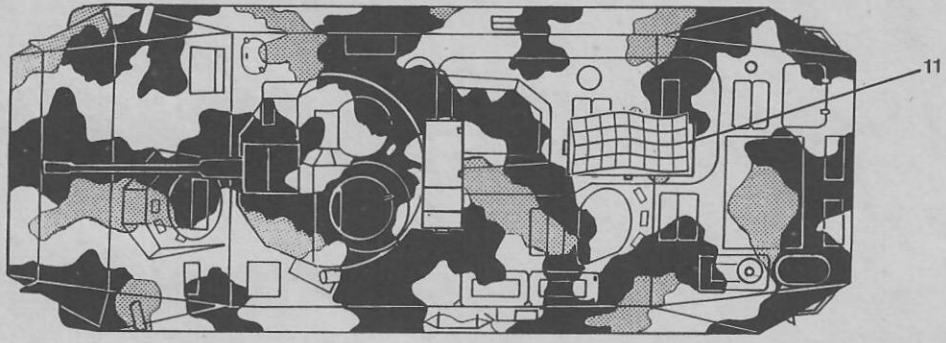
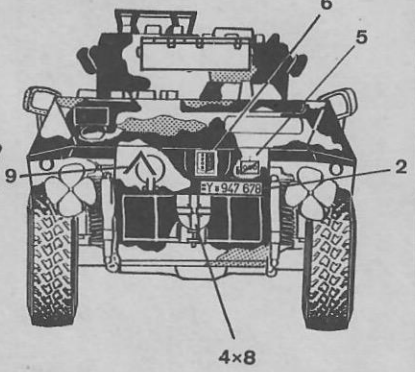
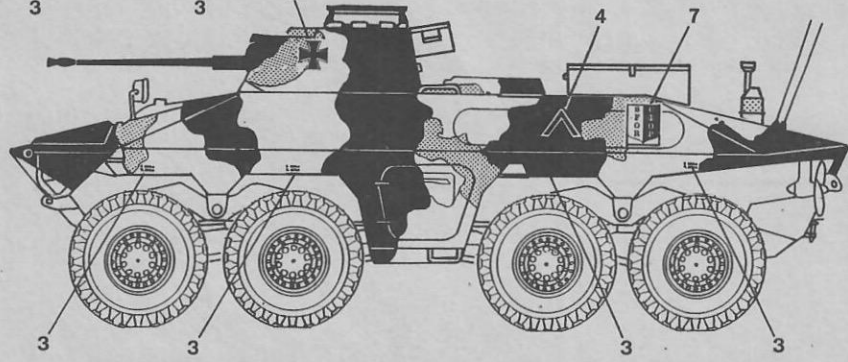
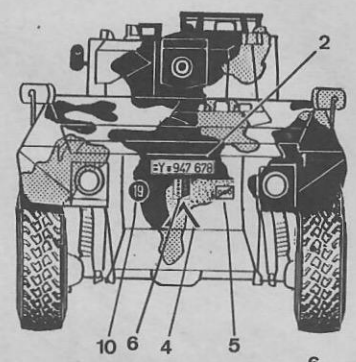
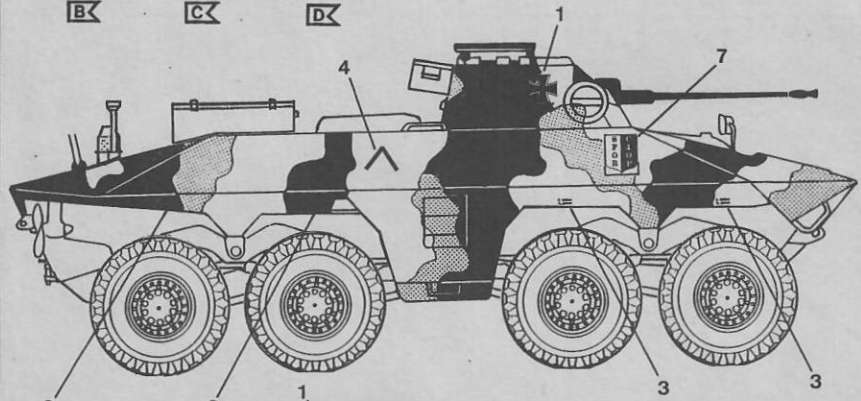
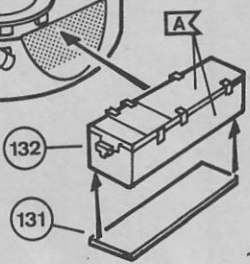
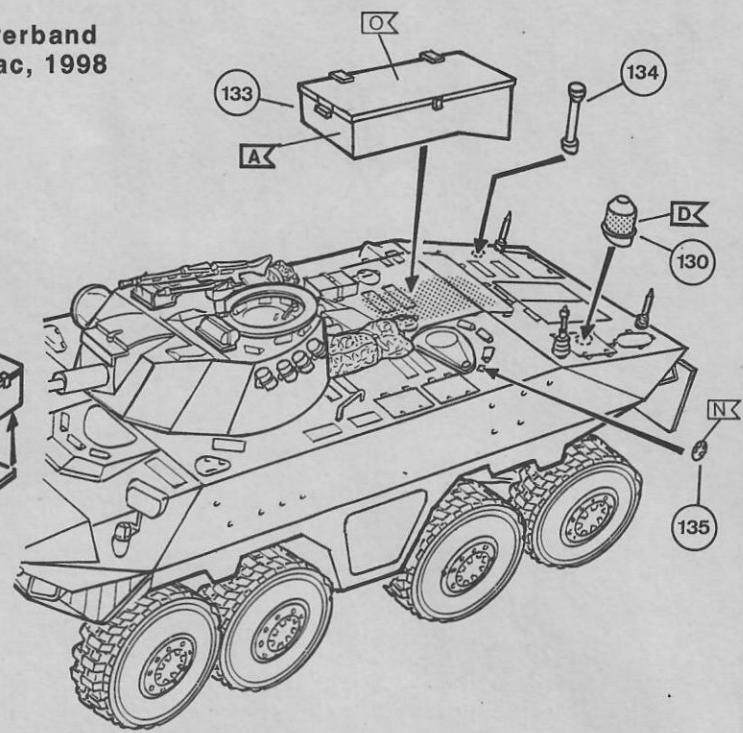
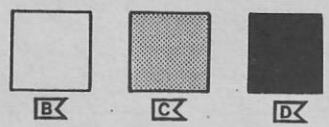

50 ?

### 3.gepanzertes Einsatzverband GECON SFOR, Rajlovac, 1998

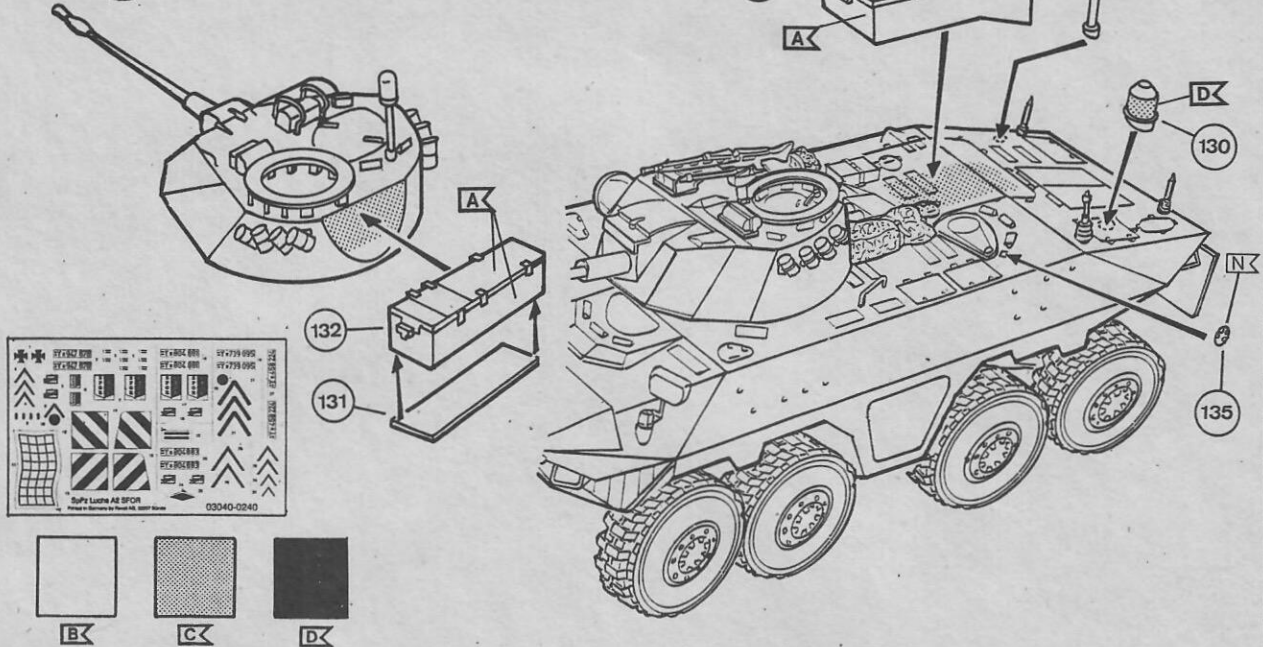

	EF 739 000	EF 739 000	EF 739 000	EF 739 000
	EF 739 000	EF 739 000	EF 739 000	EF 739 000
	EF 739 000	EF 739 000	EF 739 000	EF 739 000
	EF 739 000	EF 739 000	EF 739 000	EF 739 000
	EF 739 000	EF 739 000	EF 739 000	EF 739 000
	EF 739 000	EF 739 000	EF 739 000	EF 739 000
	EF 739 000	EF 739 000	EF 739 000	EF 739 000
	EF 739 000	EF 739 000	EF 739 000	EF 739 000
	EF 739 000	EF 739 000	EF 739 000	EF 739 000
	EF 739 000	EF 739 000	EF 739 000	EF 739 000
	EF 739 000	EF 739 000	EF 739 000	EF 739 000
	EF 739 000	EF 739 000	EF 739 000	EF 739 000

3044-0240

