

# P-63E Kingcobra

**1/48 SCALE MODEL CONSTRUCTION KIT**

Ready to assemble scale models kit.

Contains part for one model.

Model length: 208 mm

Wingspan: 244 mm

Plastic parts: 136

Photoetched parts: 34

An entirely different two-seater was produced by the Bell company for internal use. Two P-63E-1s were modified by Bell with a separate observer seat in the rear fuselage, located behind the engine and mounted under a separate canopy. A probe was mounted which extended through the spinner, and to make space for the observer the radio equipment had to be moved forward into the armament bay. The aircraft carried the civilian registrations NX41963 and Nx41964.

## PARTS OF THE MODEL

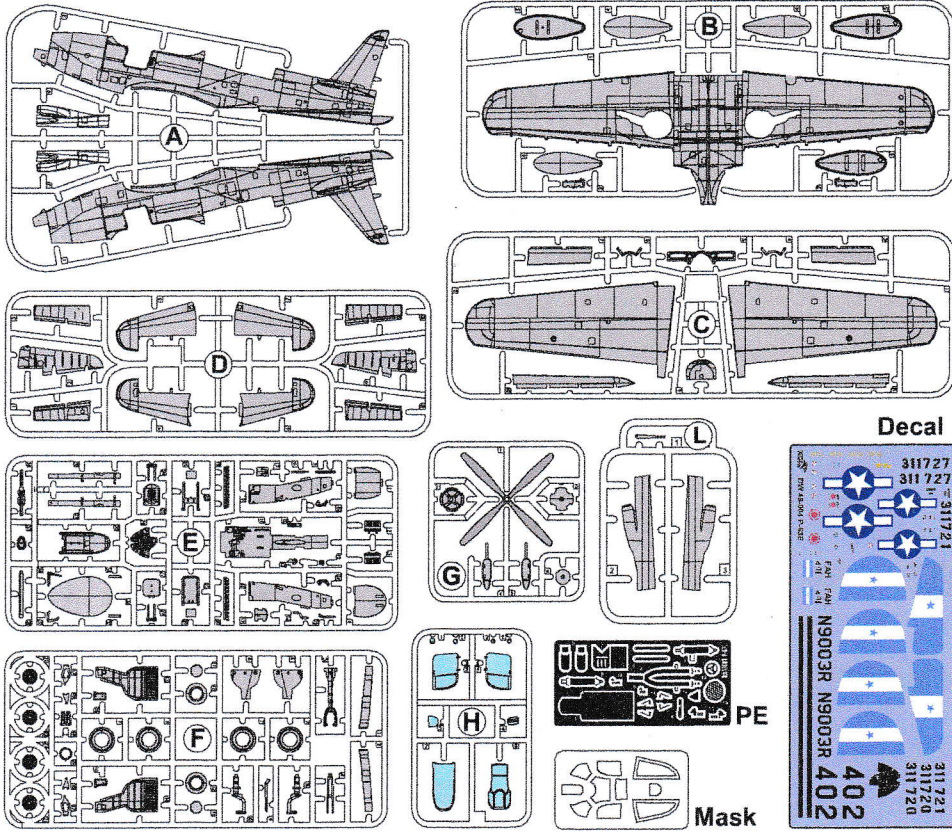

**ASSEMBLY INSTRUCTION**

**1**

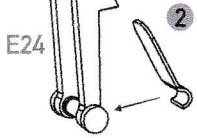

**2**

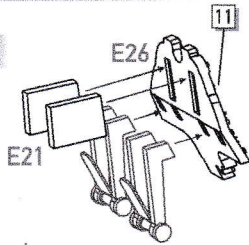

**3**

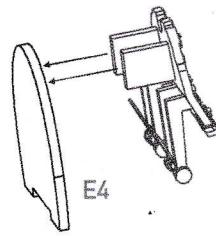

**4**

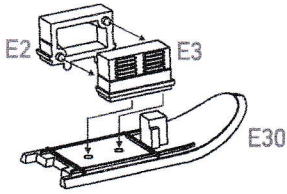

**5**

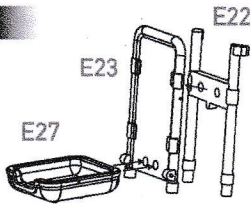

**6**

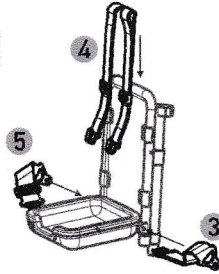

**7**

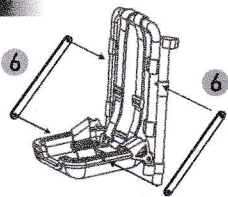

**8**

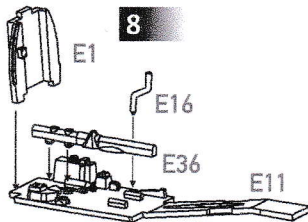

**9**

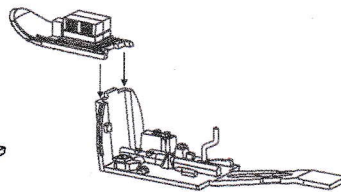

**10**

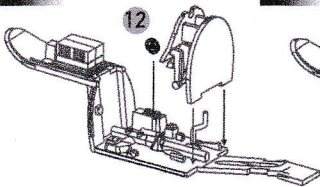

**11**

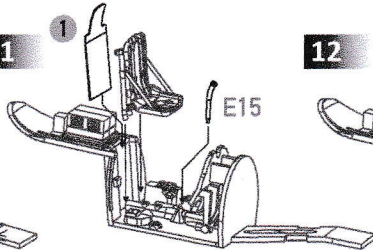

**12**

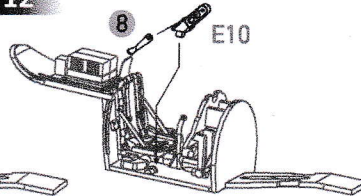

**13**

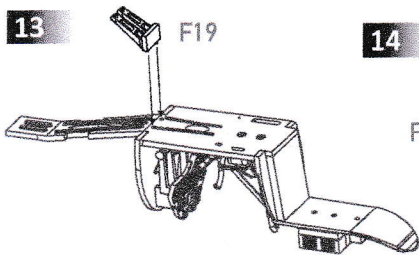

**14**

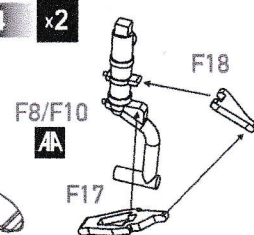

**x2**

**15**

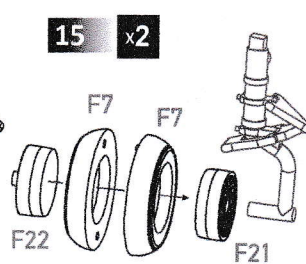

**x2**

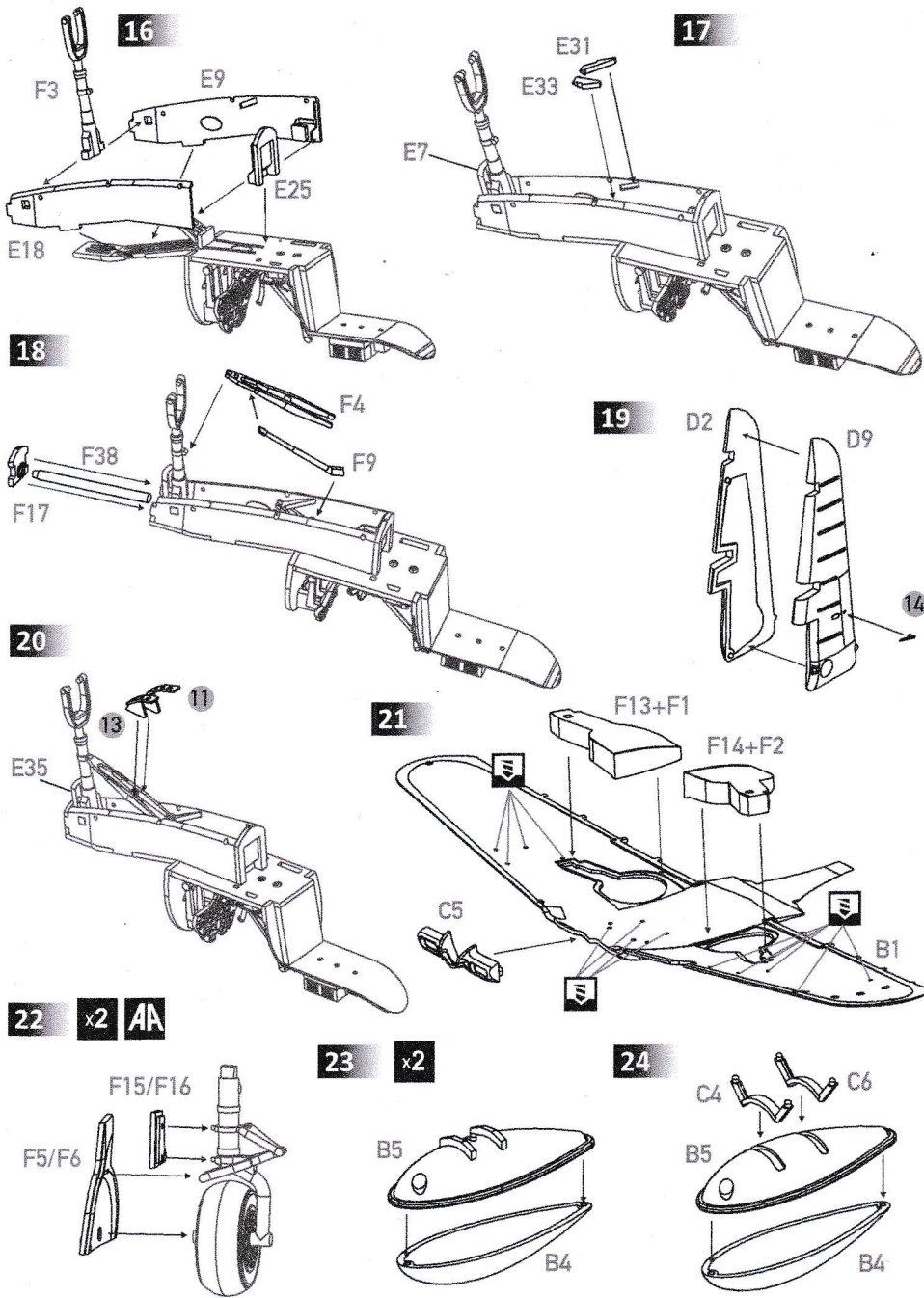

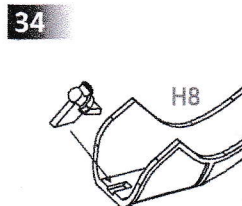
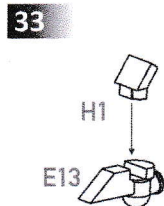
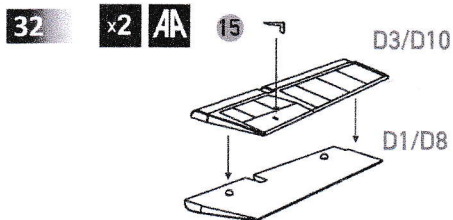
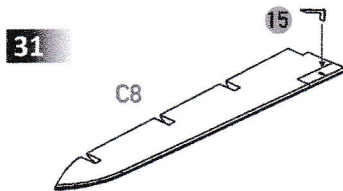
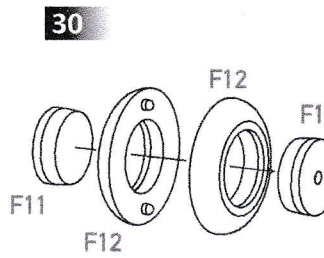
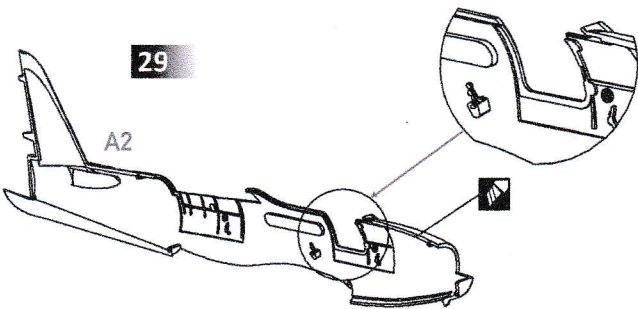
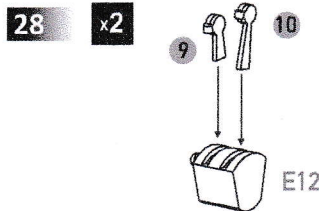
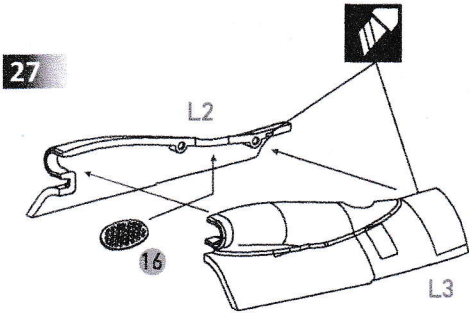
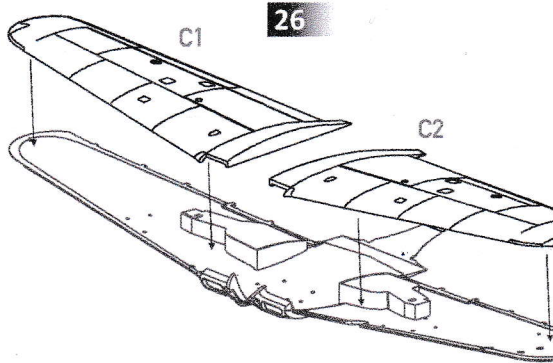
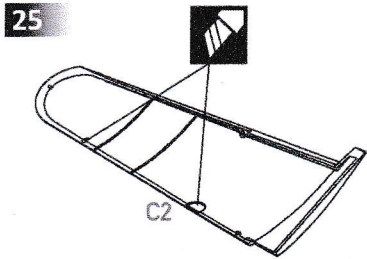

35

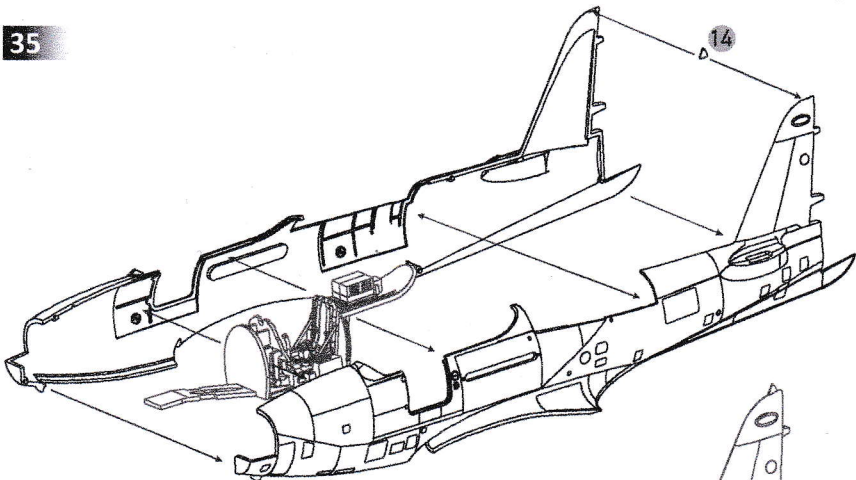

36

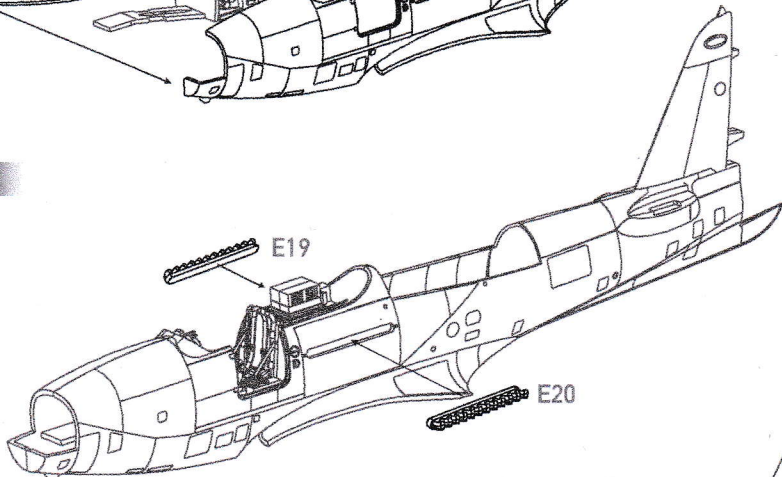

37

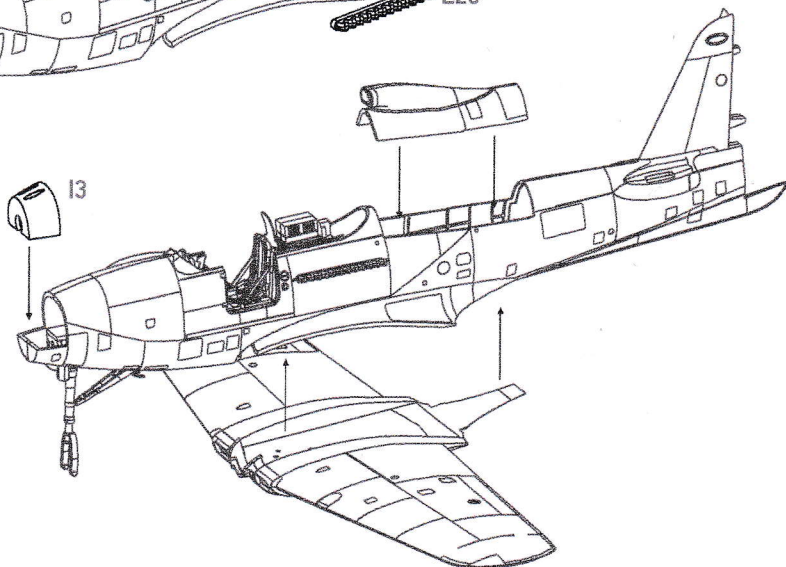

38

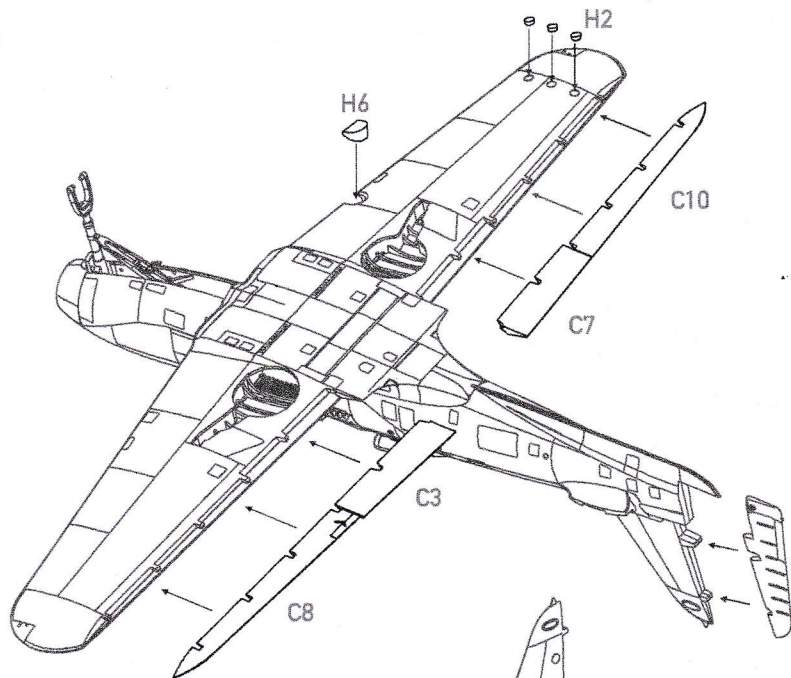

39

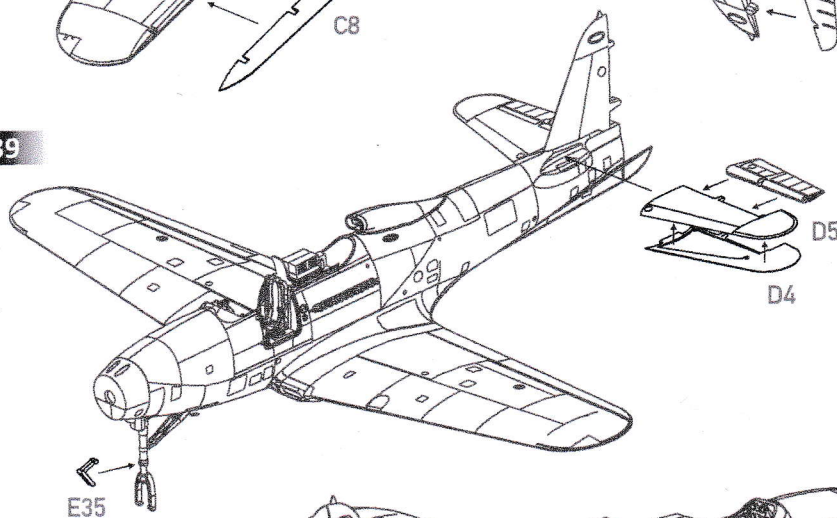

40

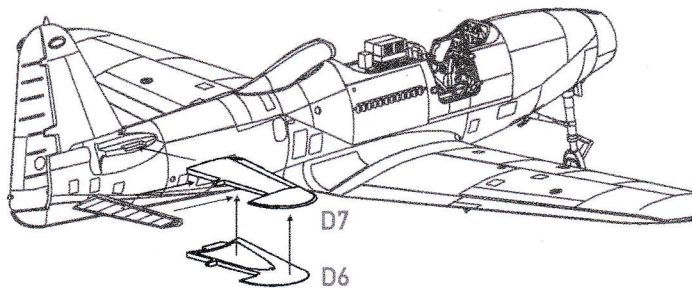

41

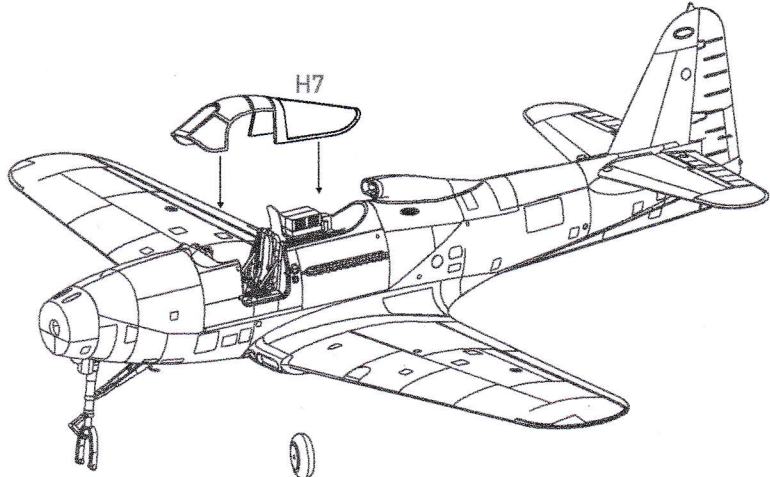

42

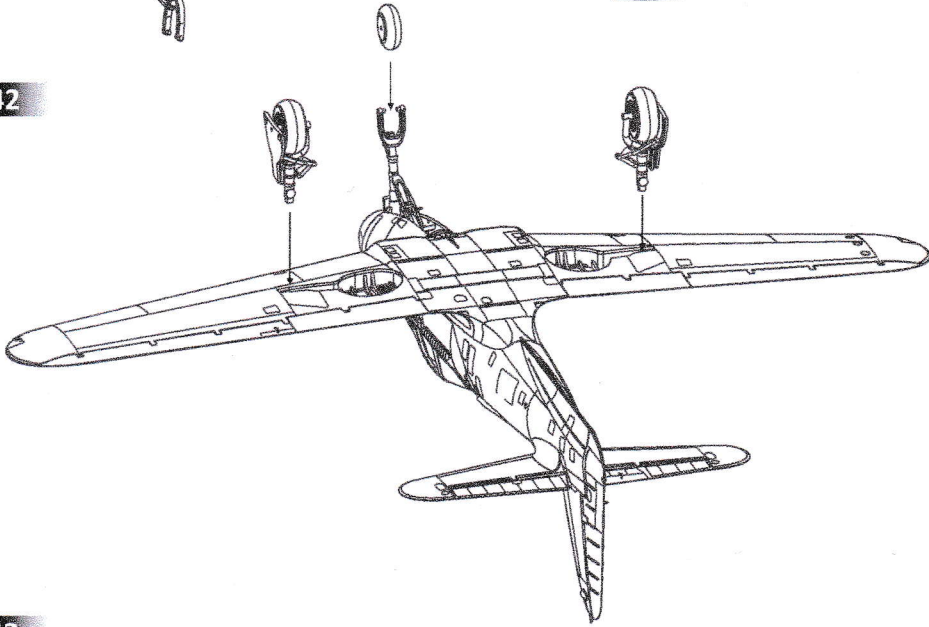

43

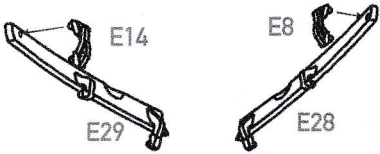

44

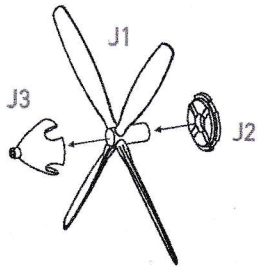

45

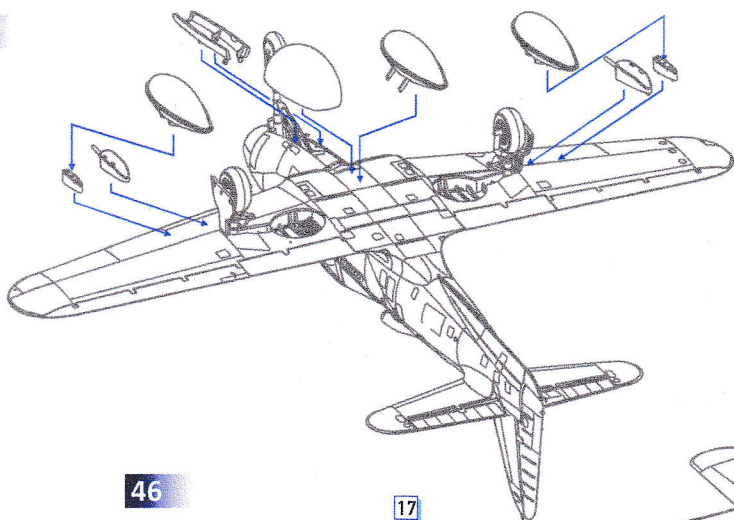

46

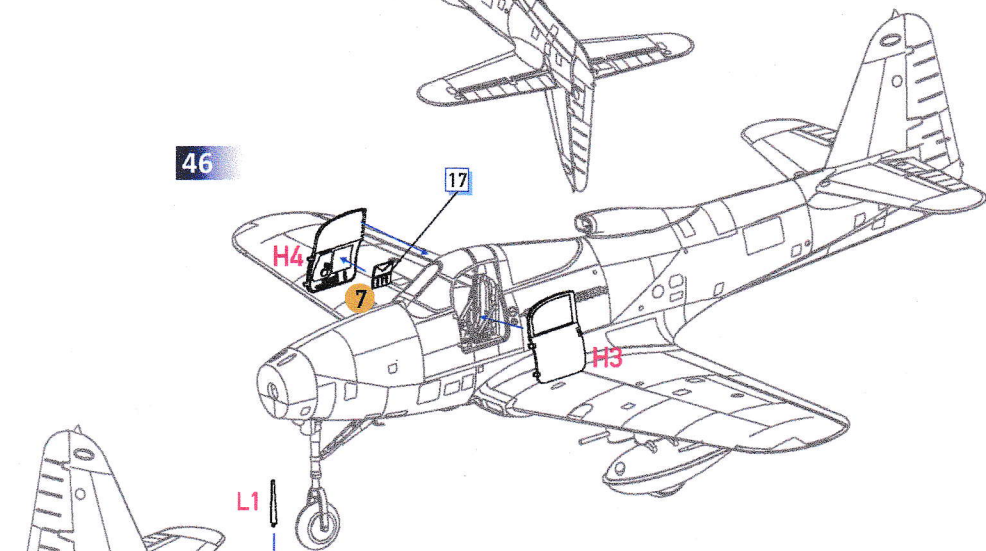

47

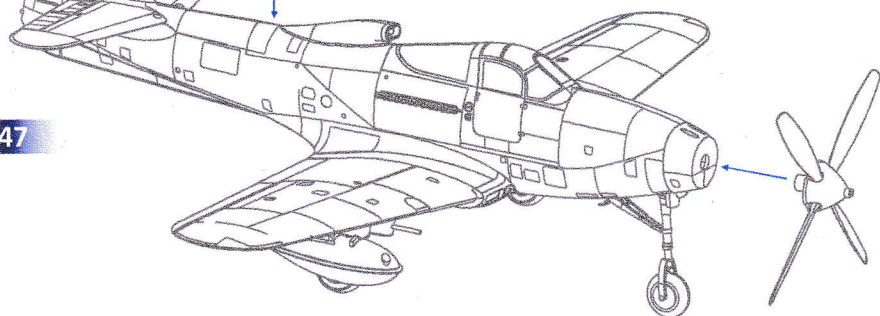

USED SYMBOLS





# COLOR SCHEME

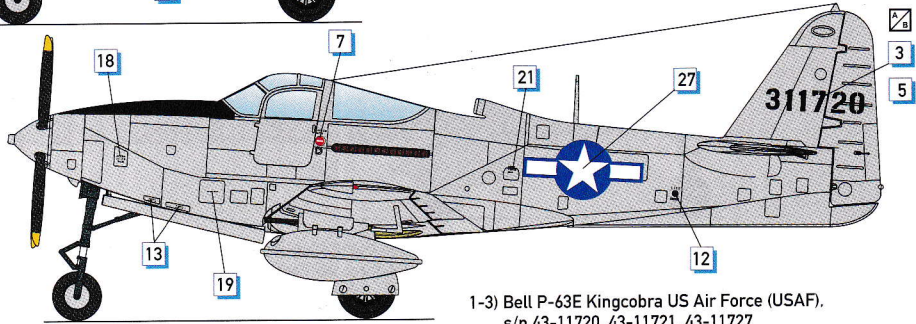
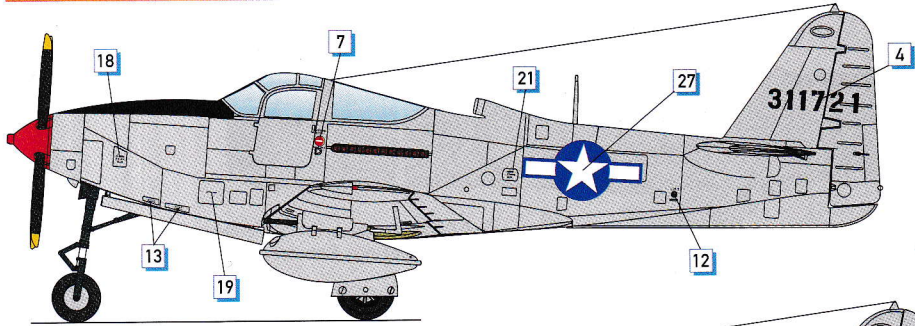

1-3) Bell P-63E Kingcobra US Air Force (USAF),  
s/n 43-11720, 43-11721, 43-11727

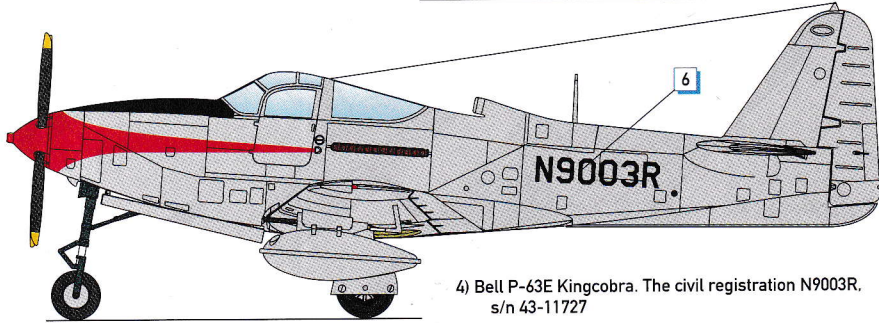
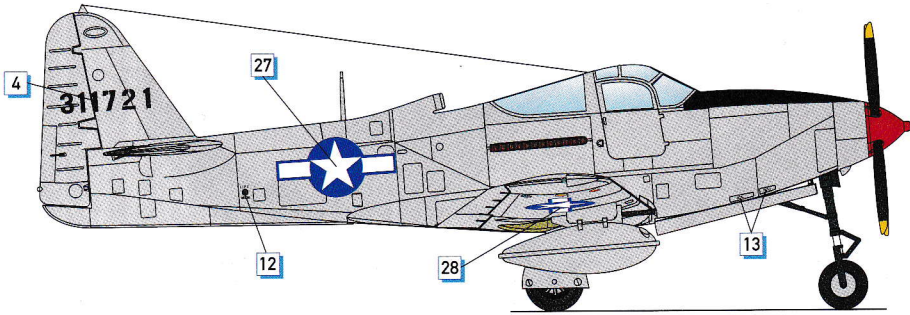

4) Bell P-63E Kingcobra. The civil registration N9003R,  
s/n 43-11727

Aluminum Humbrol 56	Red Humbrol 60	Interior Green	Matt Black Humbrol 56	Orange Humbrol 82	Green Humbrol 120	Rust Humbrol 113	Yellow Humbrol 24	Olive Drab Humbrol 66

## Bell P-63E Kingcobra

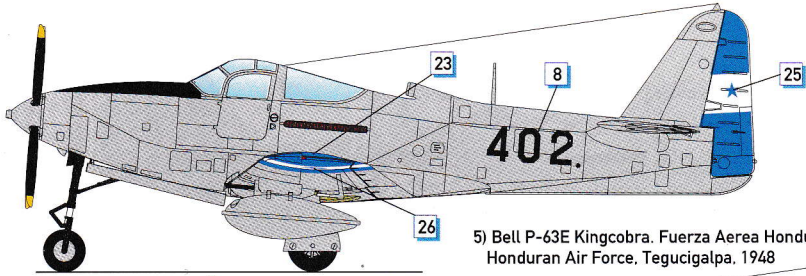

5) Bell P-63E Kingcobra. Fuerza Aerea Hondurena FAH - Honduran Air Force. Tegucigalpa. 1948

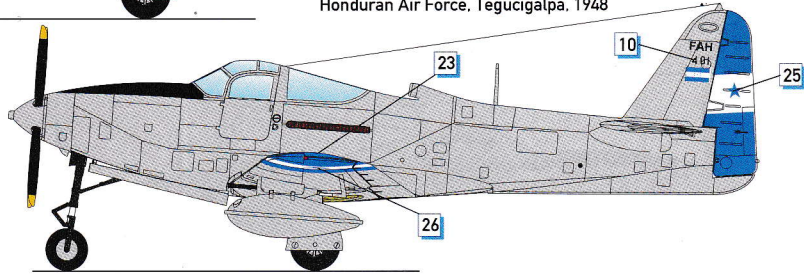

6) Bell P-63E Kingcobra. Fuerza Aerea Hondurena FAH - Honduran Air Force. Tegucigalpa. 1948

Variants 5.6

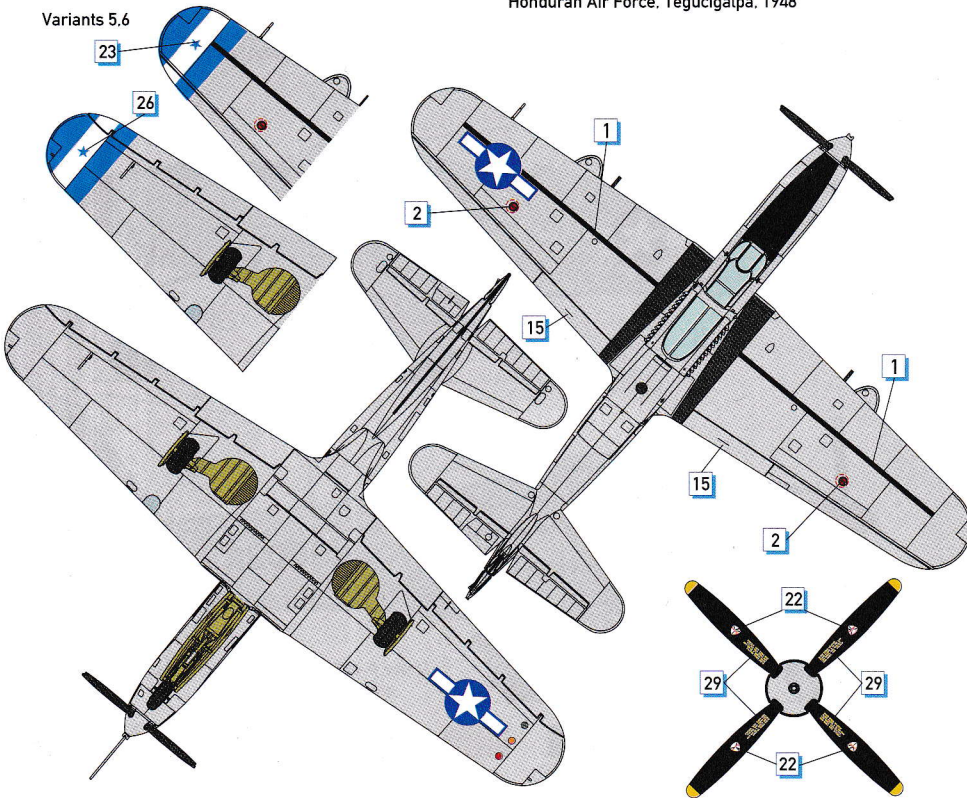

**Bell P-63E Kingcobra**