

YW-531C Armored Personnel Carrier

1/35 SCALE

YW-531C型装甲兵员运输车辆



The Norinco YW-531C was introduced in 1982 as a modernised version of the very successful YW-531A APC. It features a new powertrain based on a German KHD air cooled diesel engine, with improved transmission. Armament is usually the Type 54 12.7mm heavy machine gun and improved communications equipment has been fitted. A swimming kit can be provided to give the YW-531 amphibious capability if needed. In PLA service this version is designated the Type 63C, and has been exported to several overseas countries such as Albania, Congo, Iraq, North Korea, Sudan, Tanzania, Vietnam and Zimbabwe. It has also been used for specialist roles replacing the older YW-531A, though some older vehicles may have been re-built to 'C' standard. The YW-531C was used in the Gulf War by Iraq were many were captured and some are on display in museums.

Short Story by Phil Greenwood

Der YW-531C wurde 1982 als modernisierte Version des sehr erfolgreichen YW-531A eingeführt. Das Fahrzeug hatte eine neue Antriebseinheit, basierend auf dem deutschen luftgekühlten KHD Dieselmotor (BF8L413F) sowie ein verbessertes Getriebe und Funkanlage. Die Bewaffnung besteht aus einem schweren Type 54 12,7 mm MG. Eine amphibische Ausrüstung war bei Bedarf ebenfalls verfügbar. Bei der Volksbefreiungsarmee war das Modell als Typ 63C bekannt. Ältere Fahrzeuge wurden manchmal auf den C Standard nachgerüstet. Exporte erfolgten nach Albanien, Kongo, Nordkorea, Sudan, Tansania, Vietnam und Simbabwe. Einige im Irak erbeutete YW-531C sind weltweit in Militärmuseen ausgestellt.

© Translation Michael Knoblich ACADEMY EUROPE GmbH

1982年中国北方工业公司在其早前生产非常成功的YW-531A装甲运兵车基础上设计出一款更为现代化的版本YW-531C装甲运兵车。它的动力装置主要是根据德国KHD空冷式柴油发动机为蓝本所研制出来的，并重新设计传动系统。其自卫武器是一门位于车长位置上的54式12.7mm重机枪，而且通讯器材更为现代化。YW-531装甲运兵车的优点是外形设计简洁，只需要在车身上简单增添浮水设施便可拥有两栖作战。YW-531C在中国军方所使用的同一型号被定名为63式C型；并曾出口到海外友好国家，如阿尔巴尼亚、刚果、伊拉克、北朝鲜、苏丹、坦桑尼亚、越南和津巴布韦。虽然YW-531C型开始逐步替换在服役中的旧款YW-531A，但部份的YW-531A后来也被提升到C型的规格再被使用。有许多在伊拉克军服役的YW-531C装甲运兵车在海湾战争中被英美联军俘获并陈列在各地的军事博物馆里。

DECAL & COLOUR GUIDE 水贴及涂色指示:

Option 2:
Iraqi Army, Gulf War, 1991.
1991年海湾战争之伊拉克军使用车辆

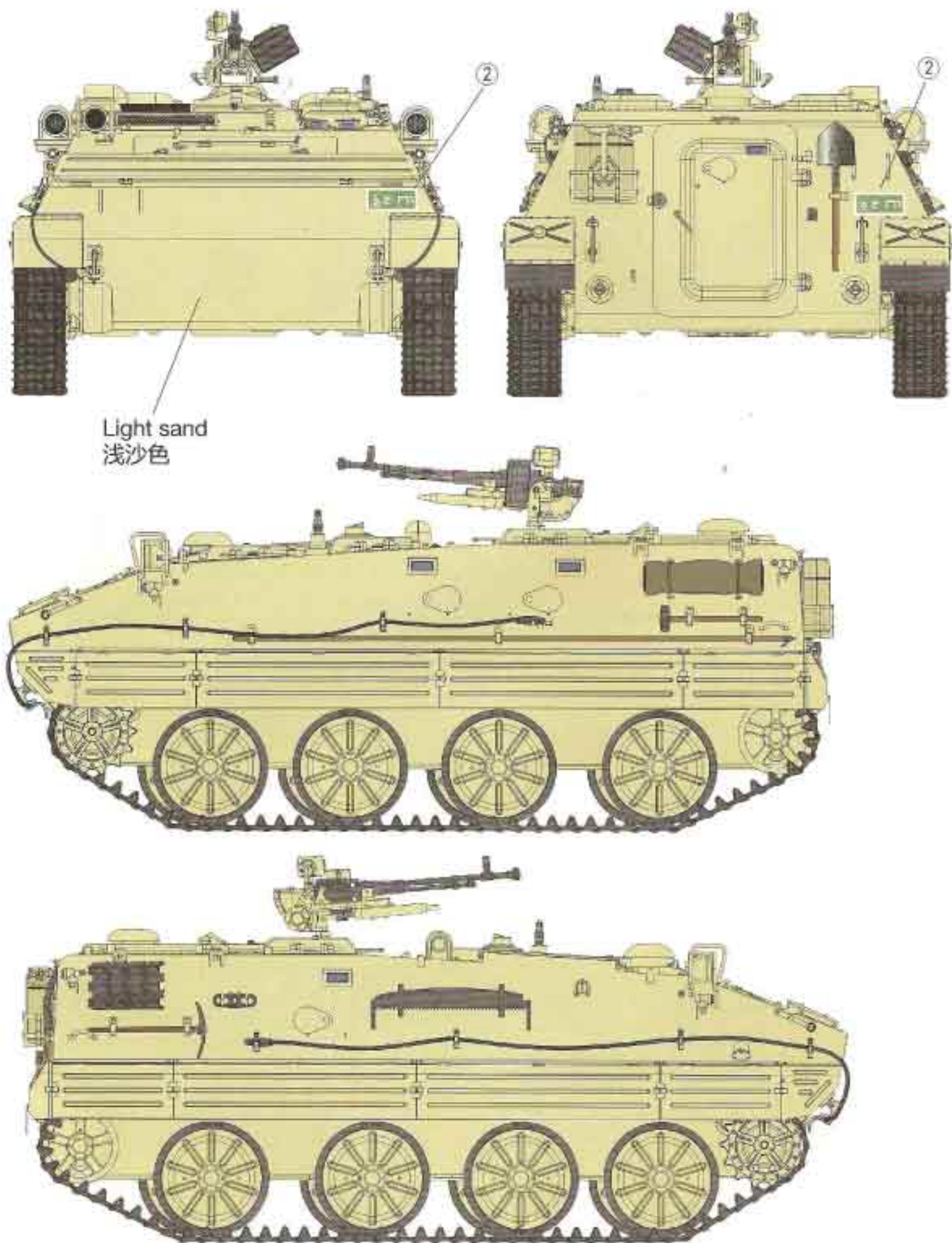

Option 1:
Iraqi Army, Gulf War, 1991.
1991年海湾战争之伊拉克军使用车辆

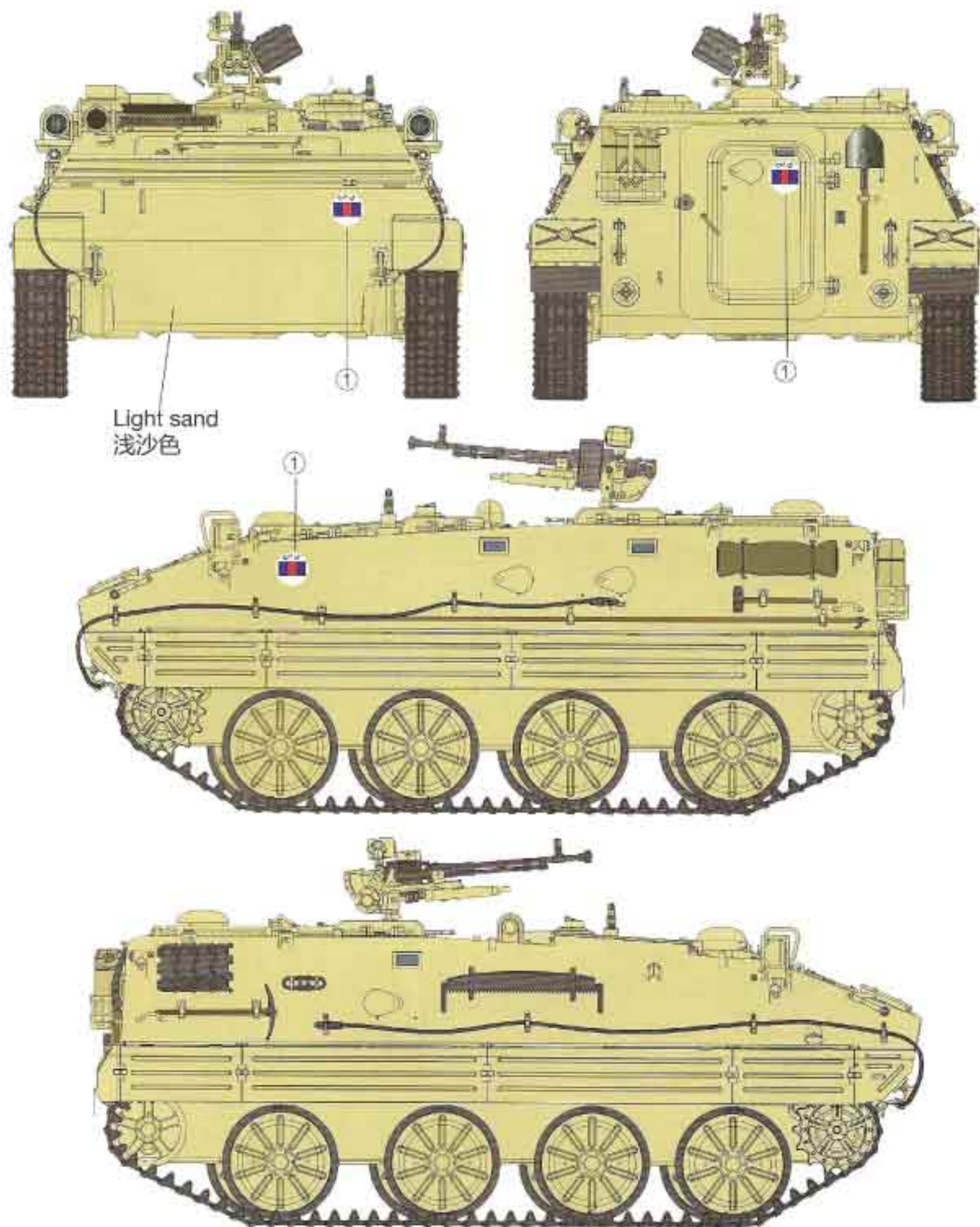
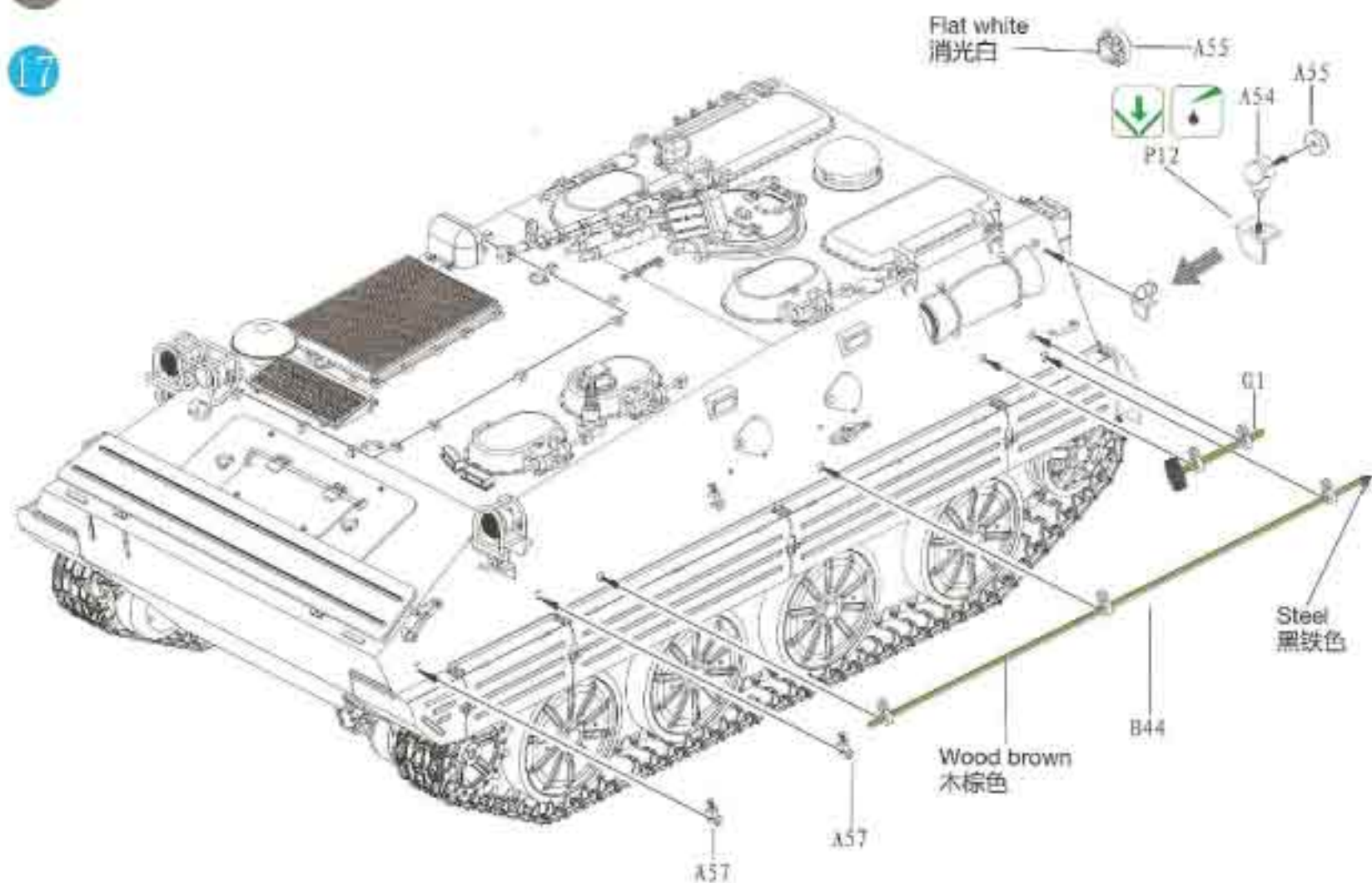

ILLUSTRATION 图示说明:

17



18

★ Caution: make the antenna by plastic frame channel with the heat of fire
 注明: 制作天线用流道加热拉丝

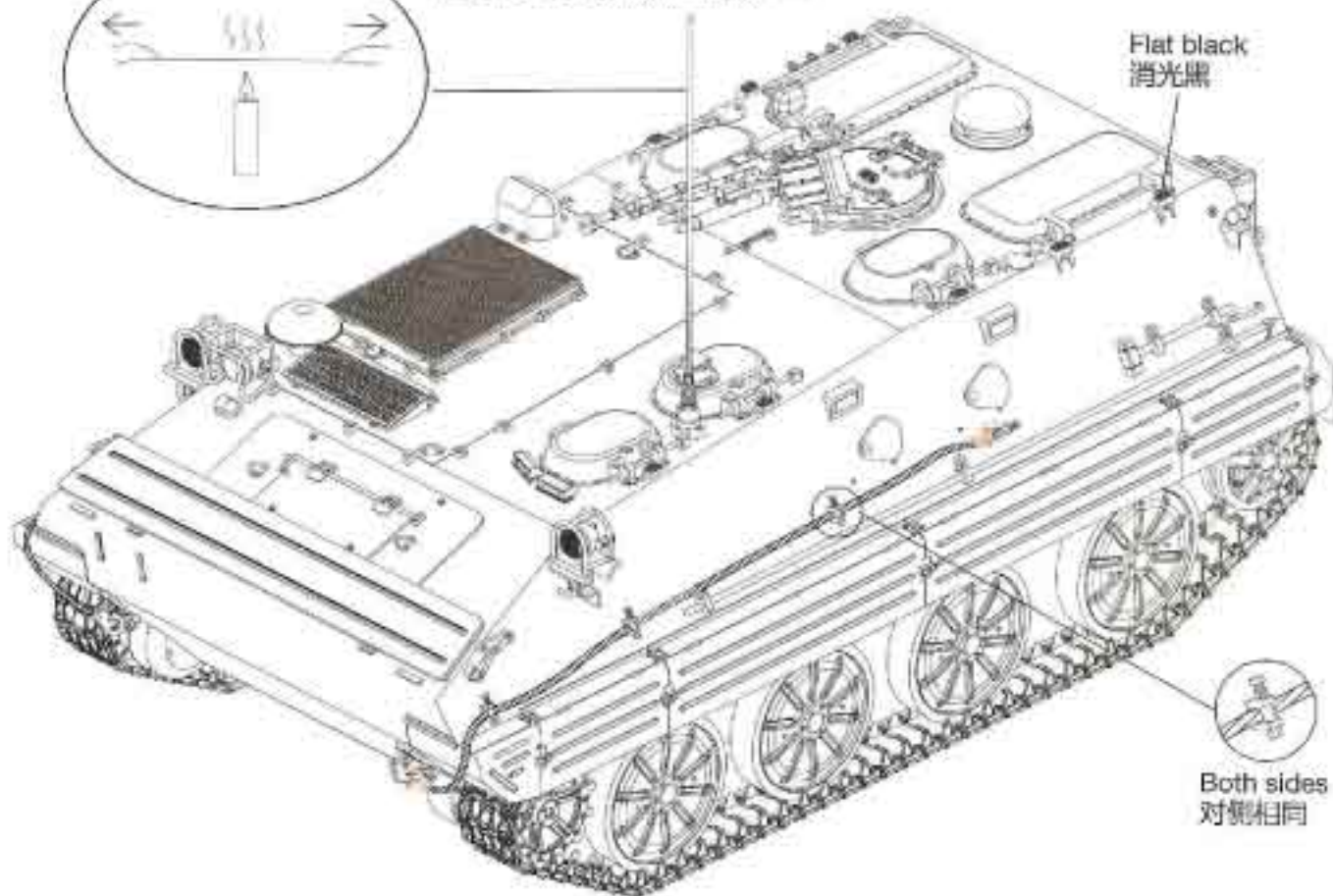
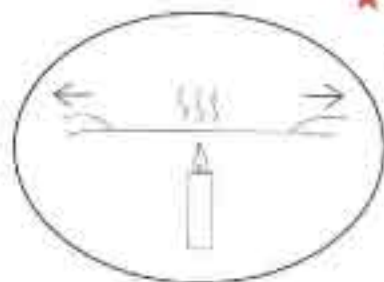

15

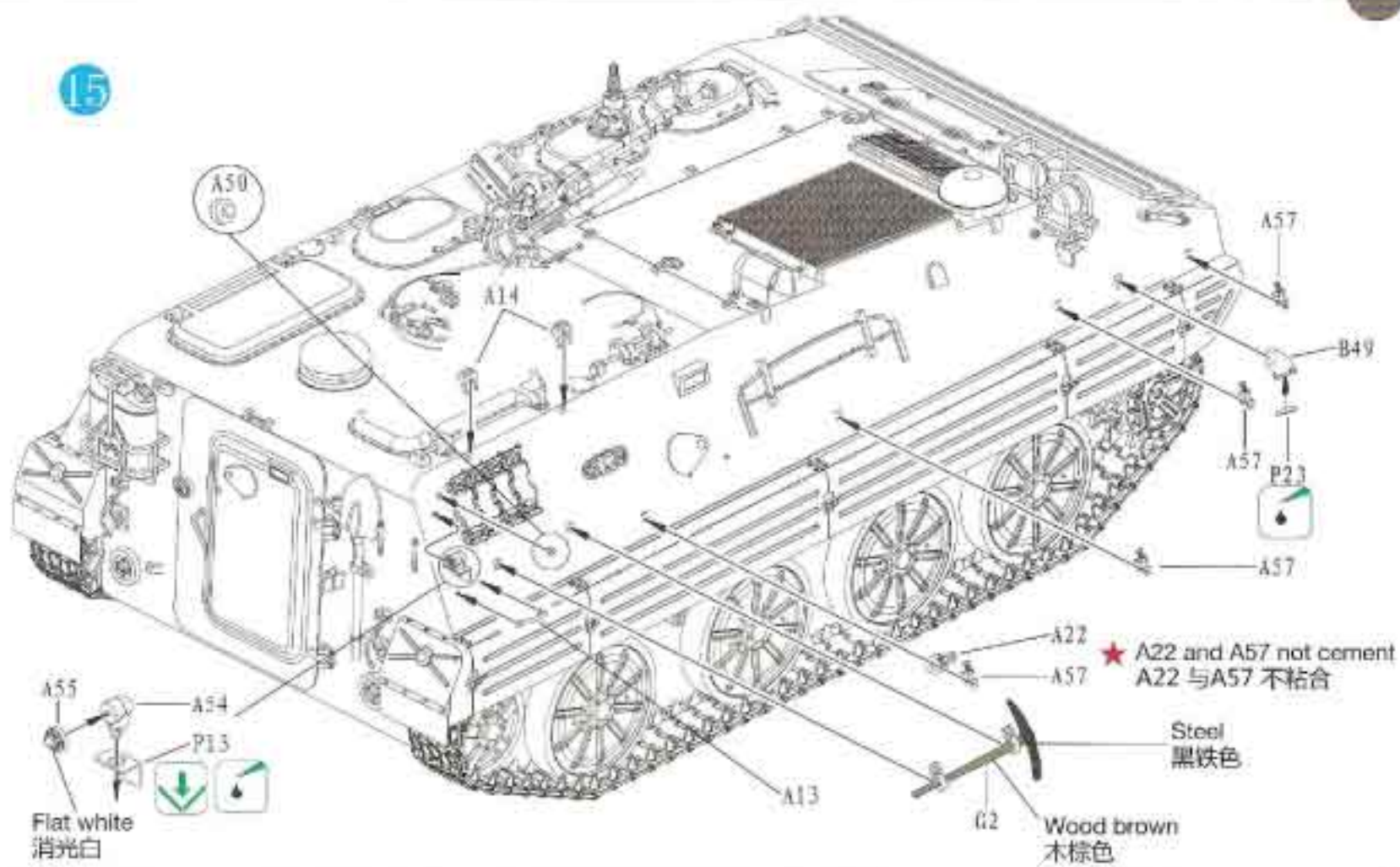

16

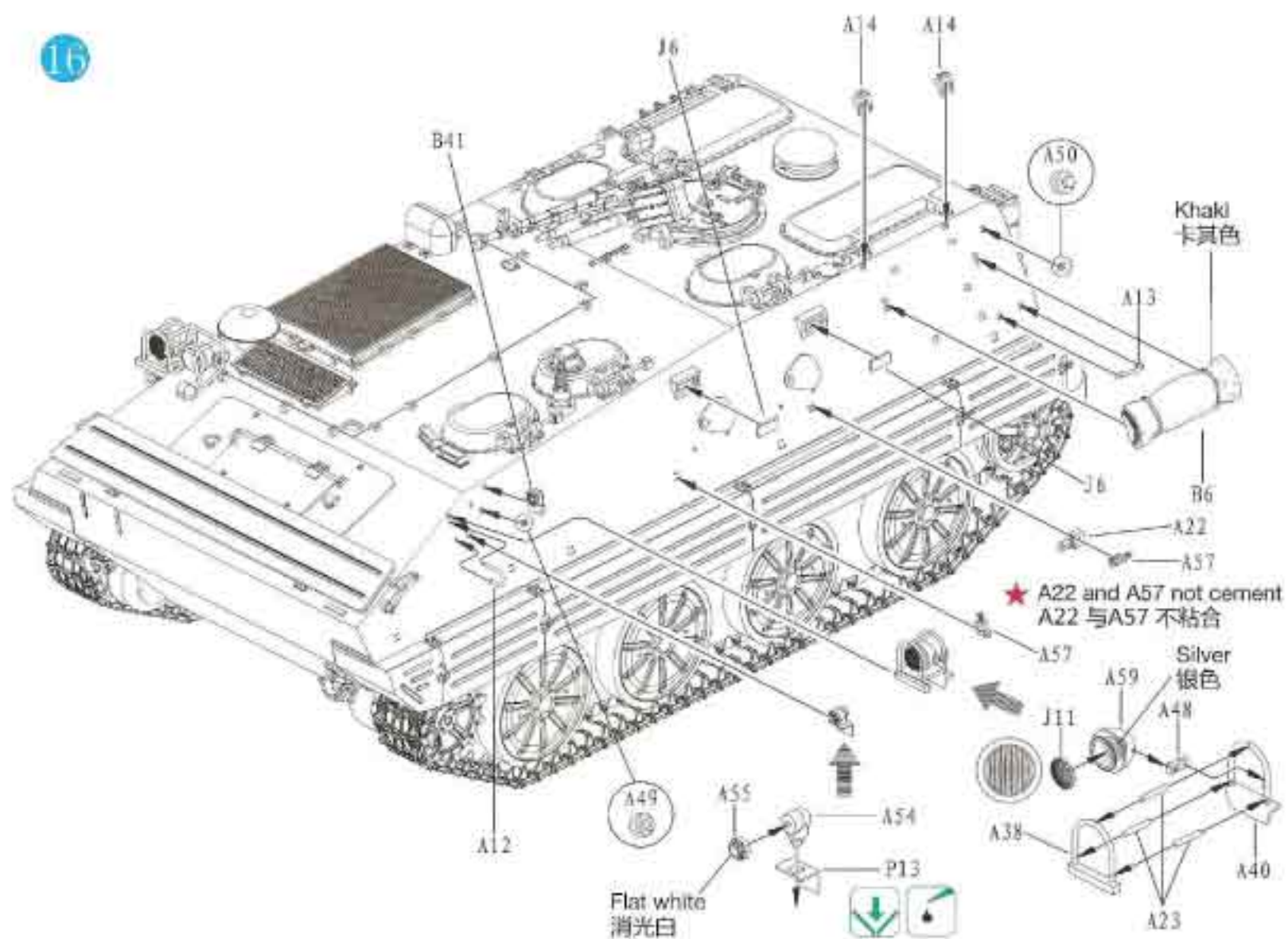
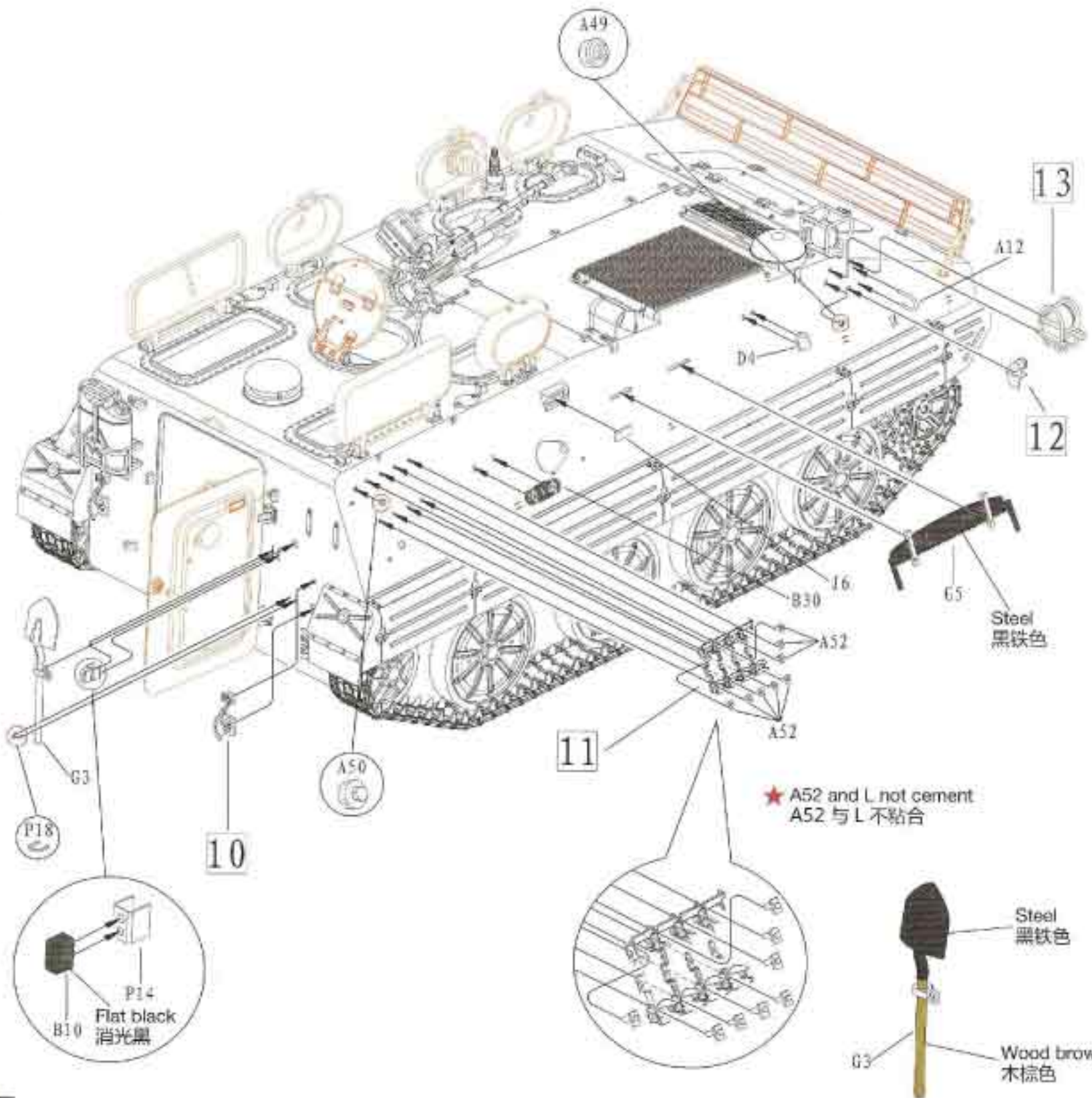
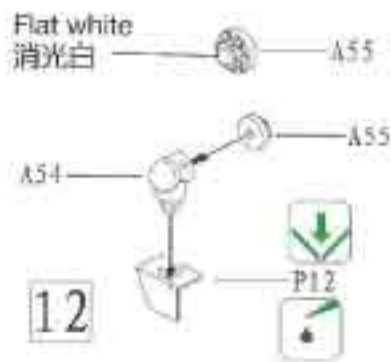
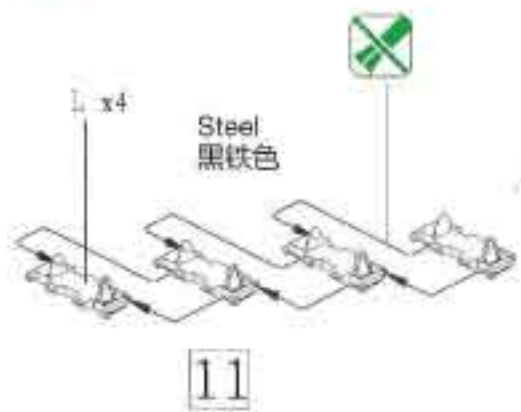

ILLUSTRATION 图示说明:

11



13 Close position
关闭状态

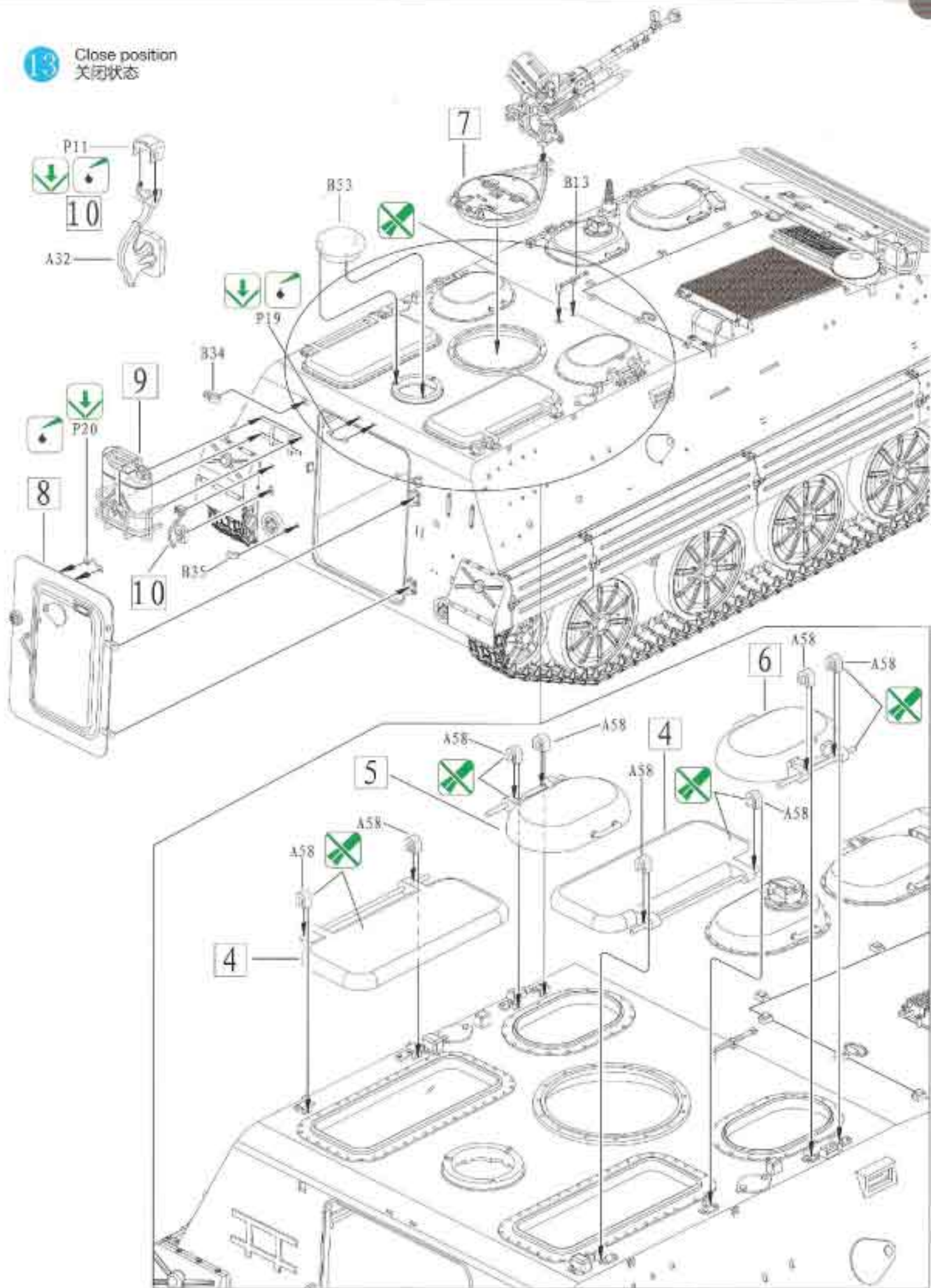
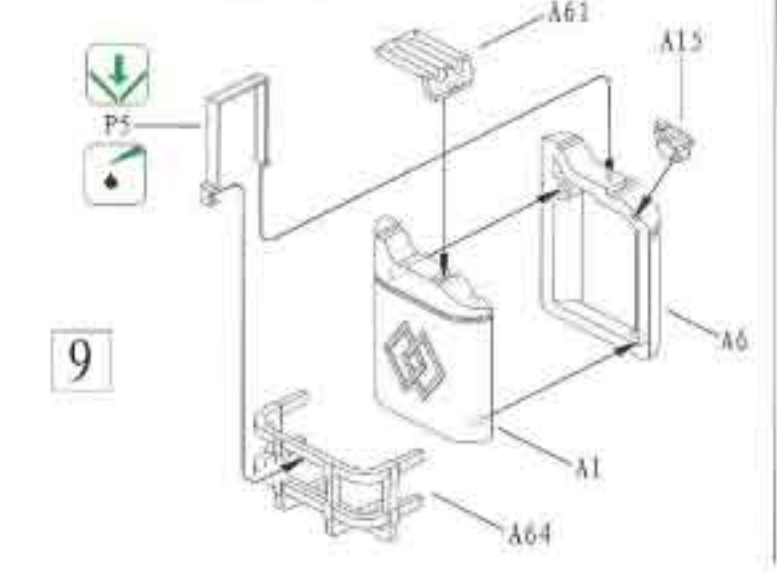
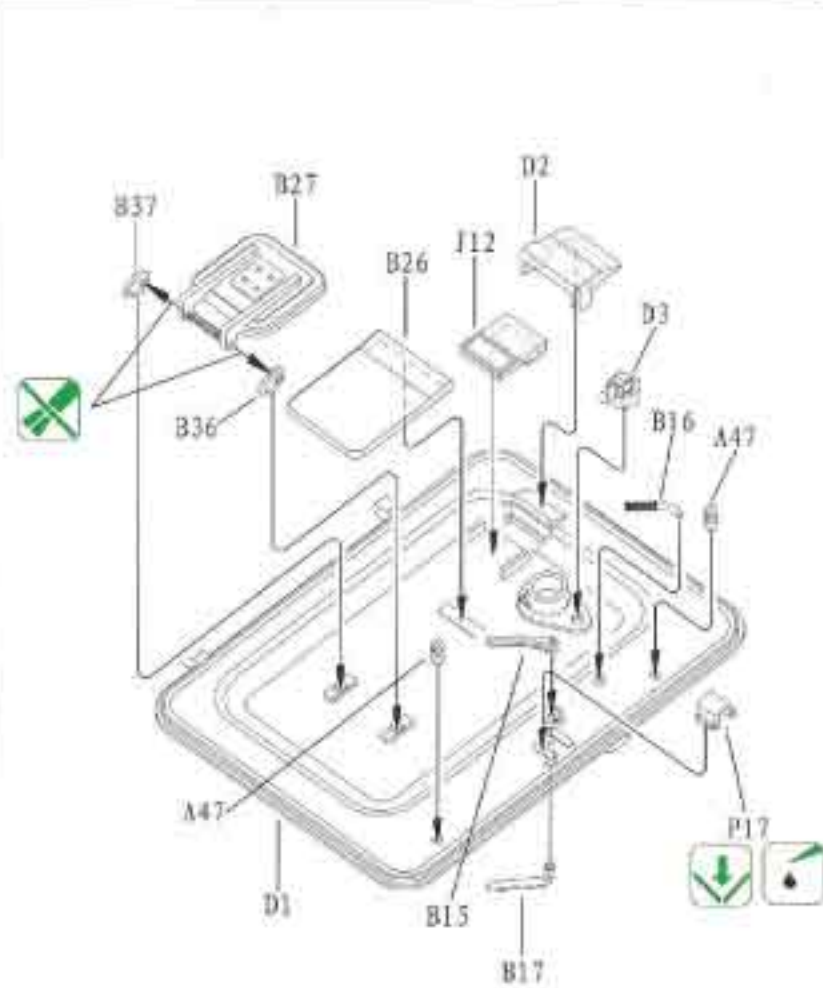
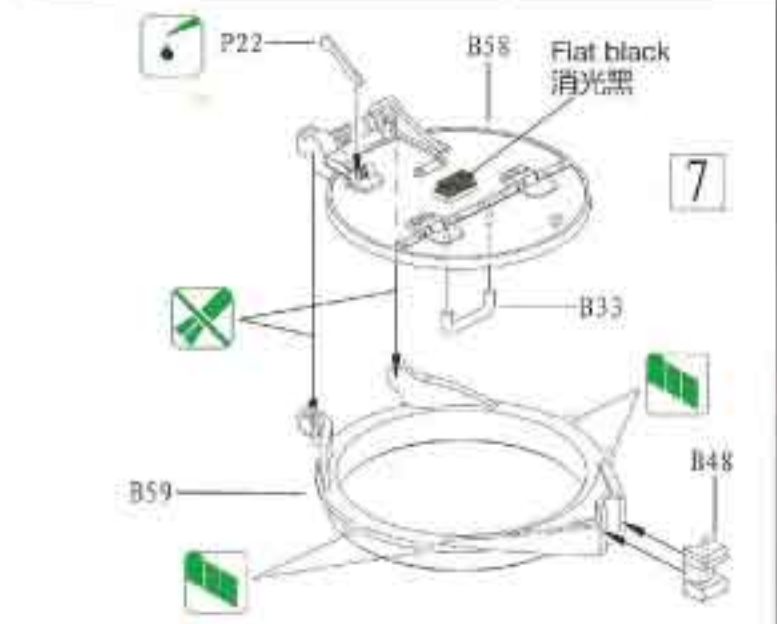
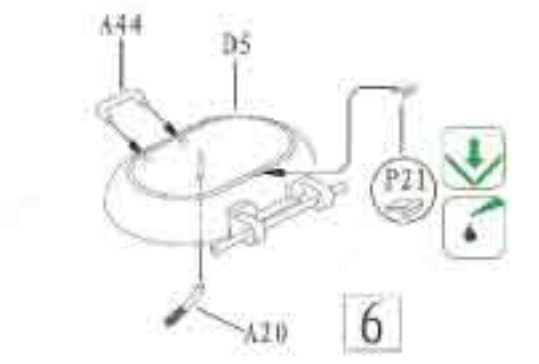
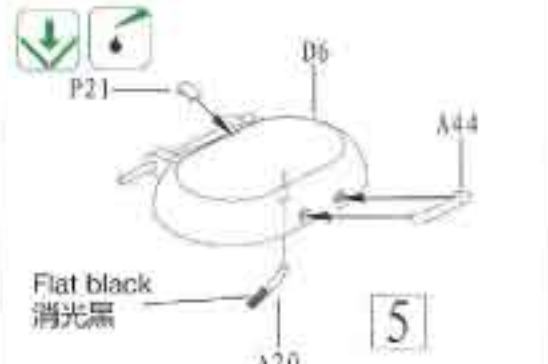
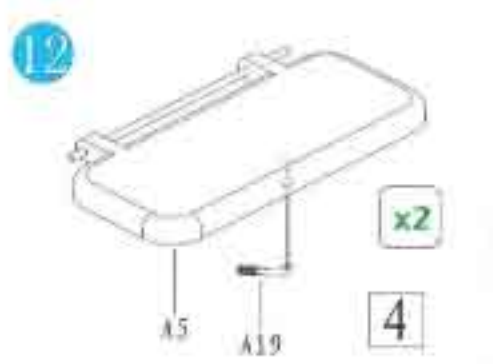
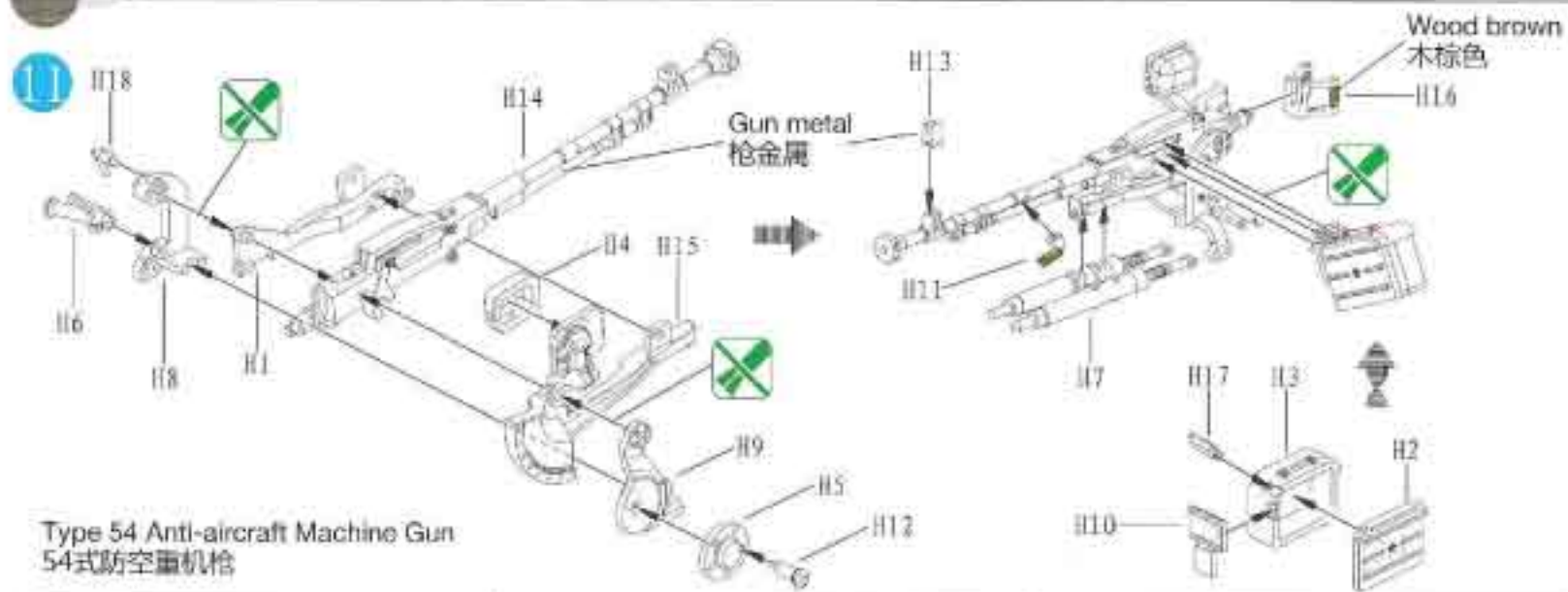
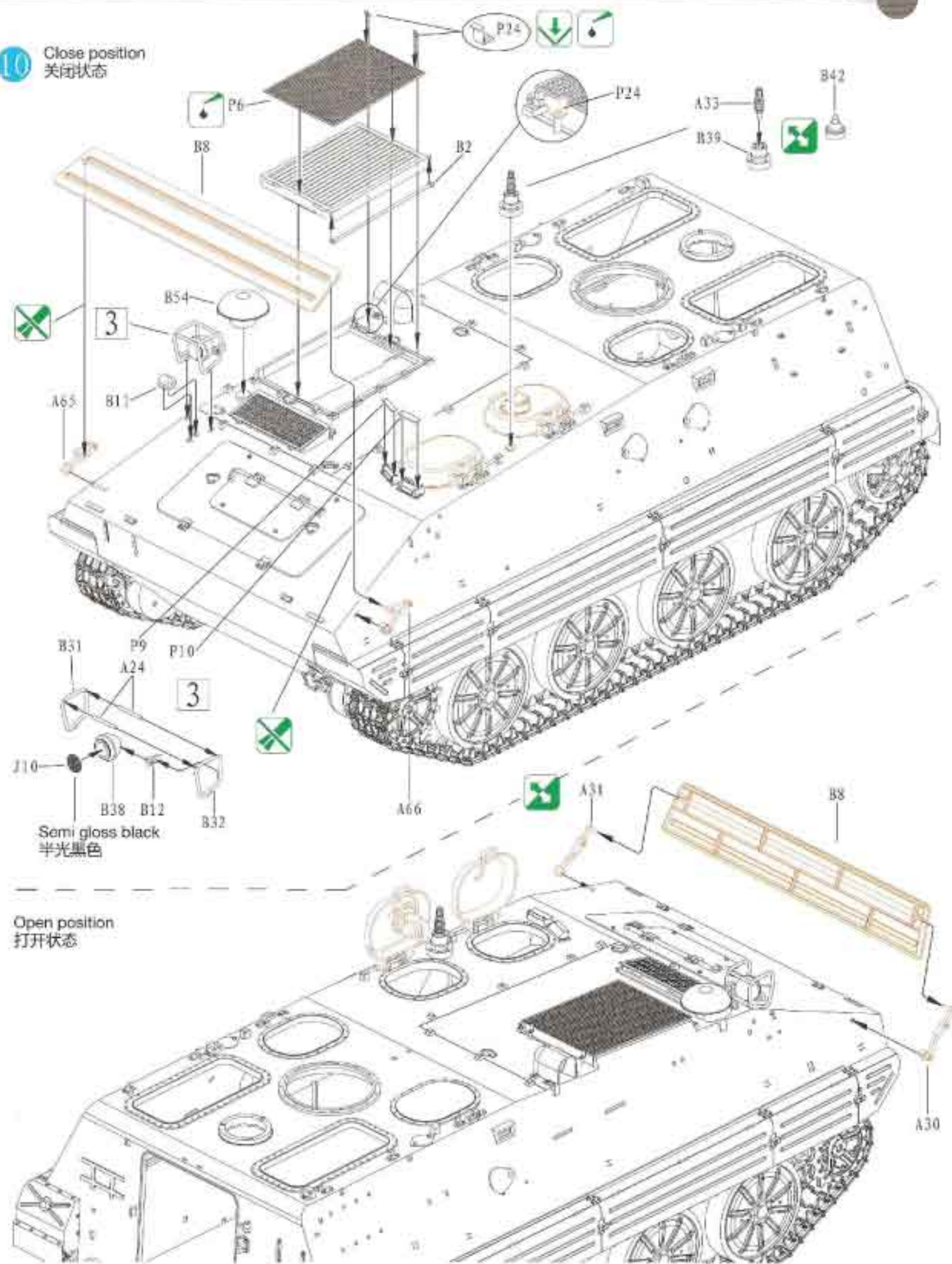

ILLUSTRATION 图示说明:



Close position
关闭状态



Open position
打开状态

ILLUSTRATION 图示说明:

9

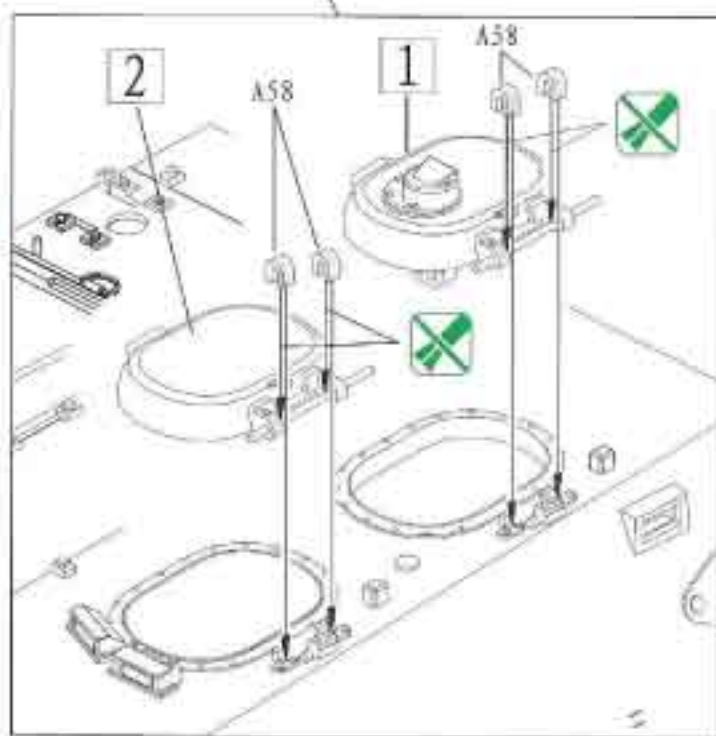
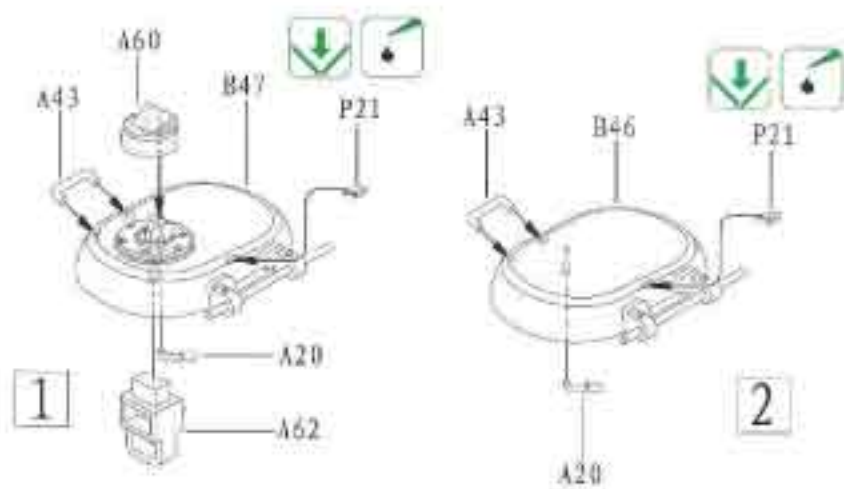
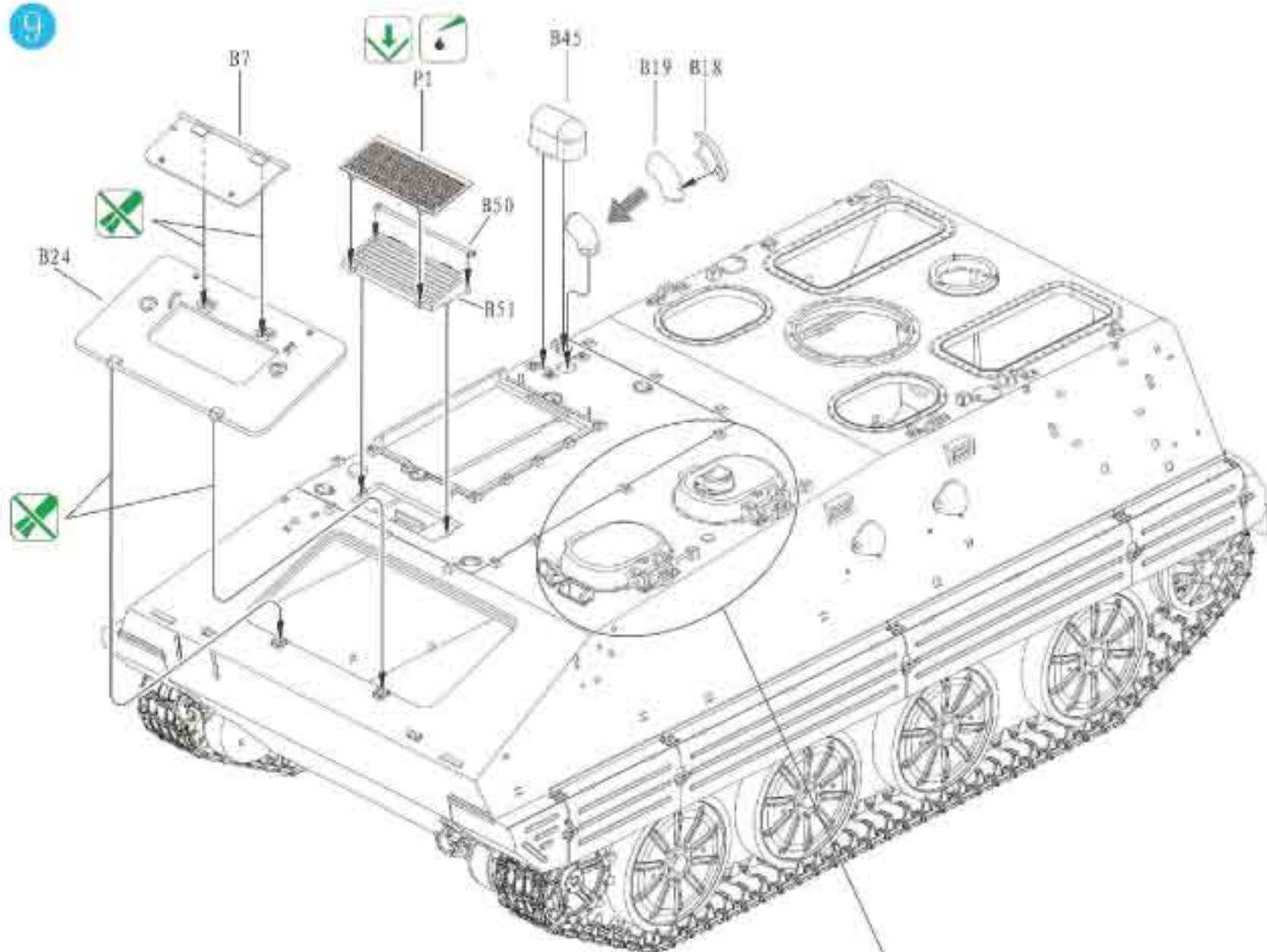

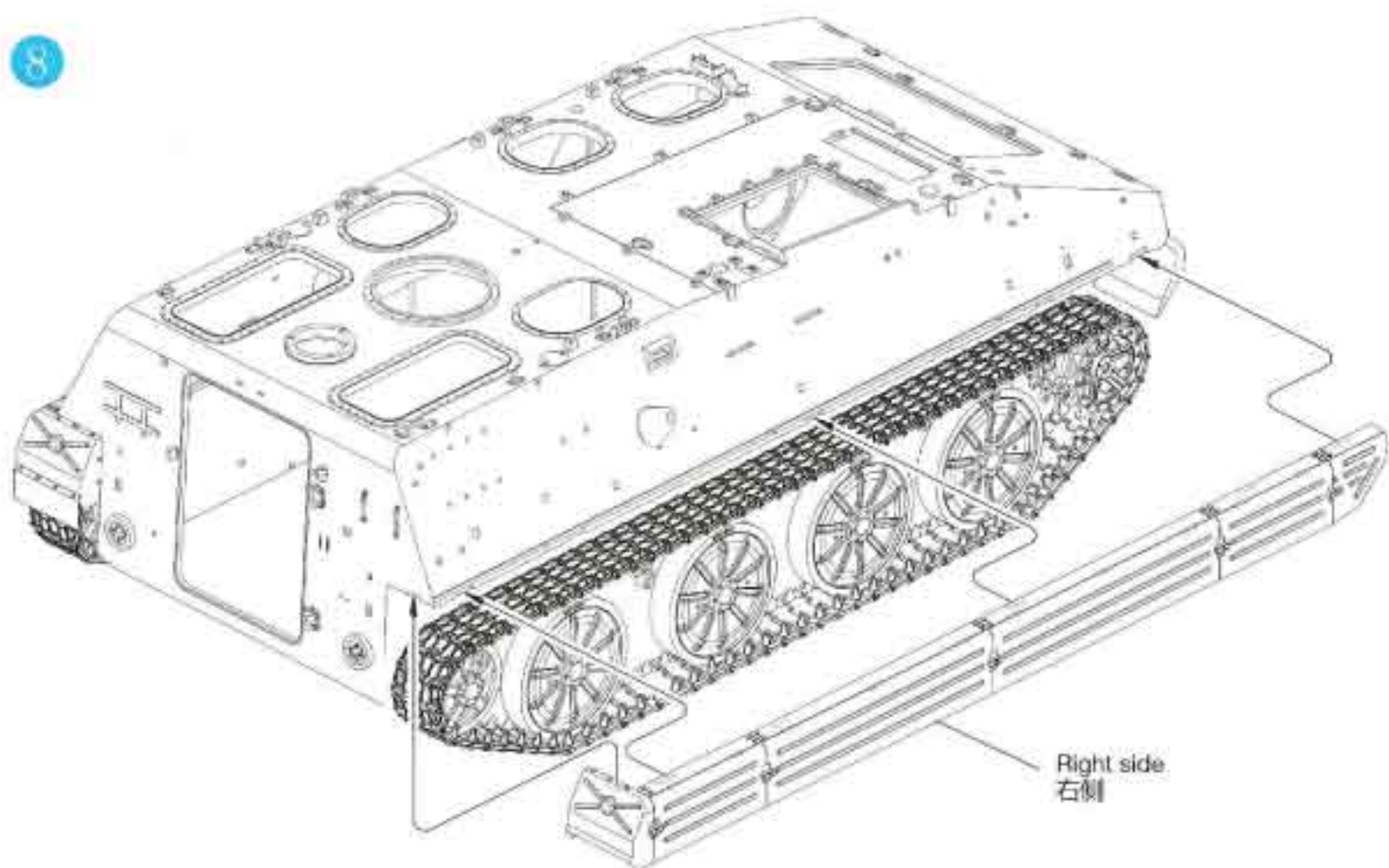
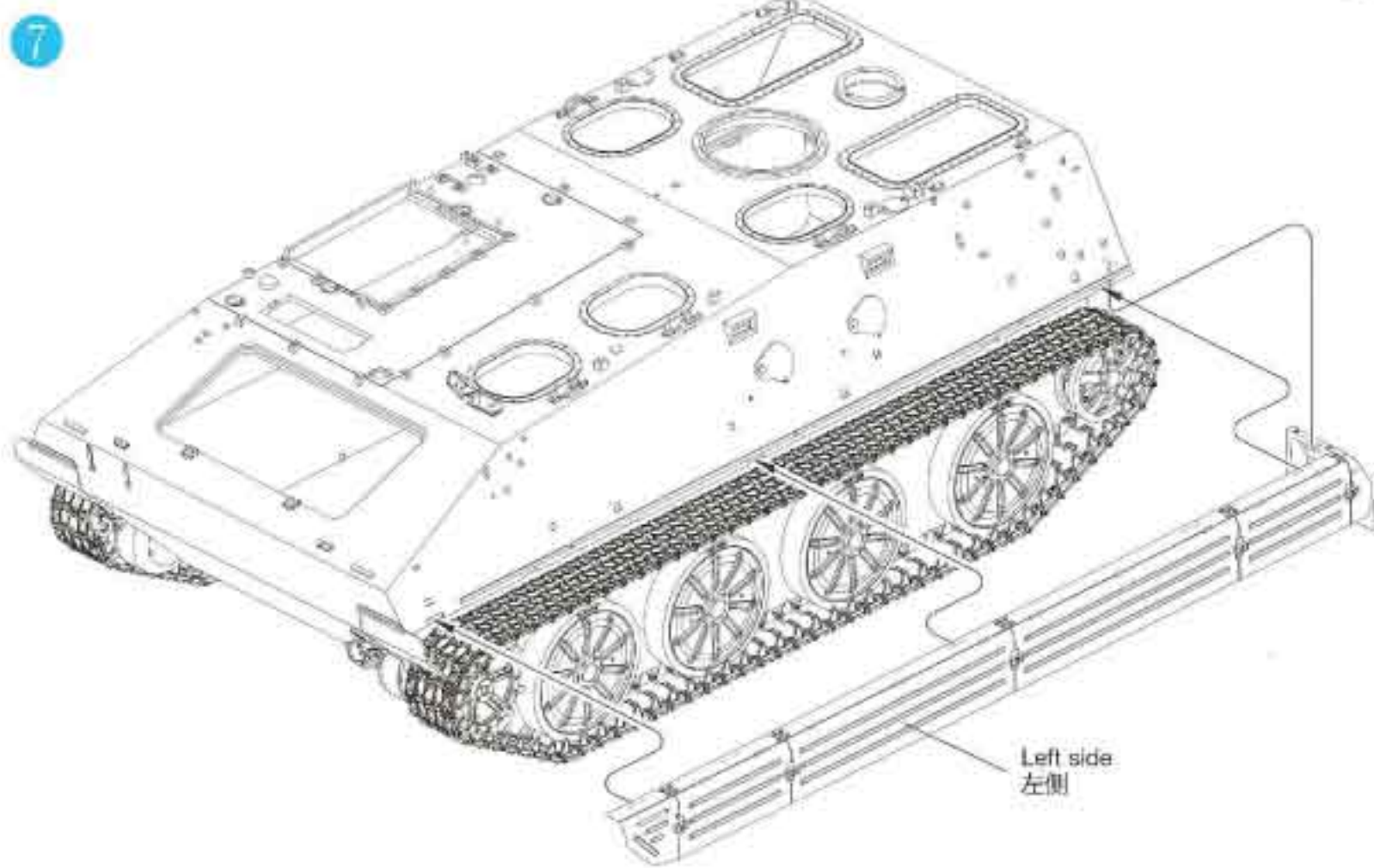
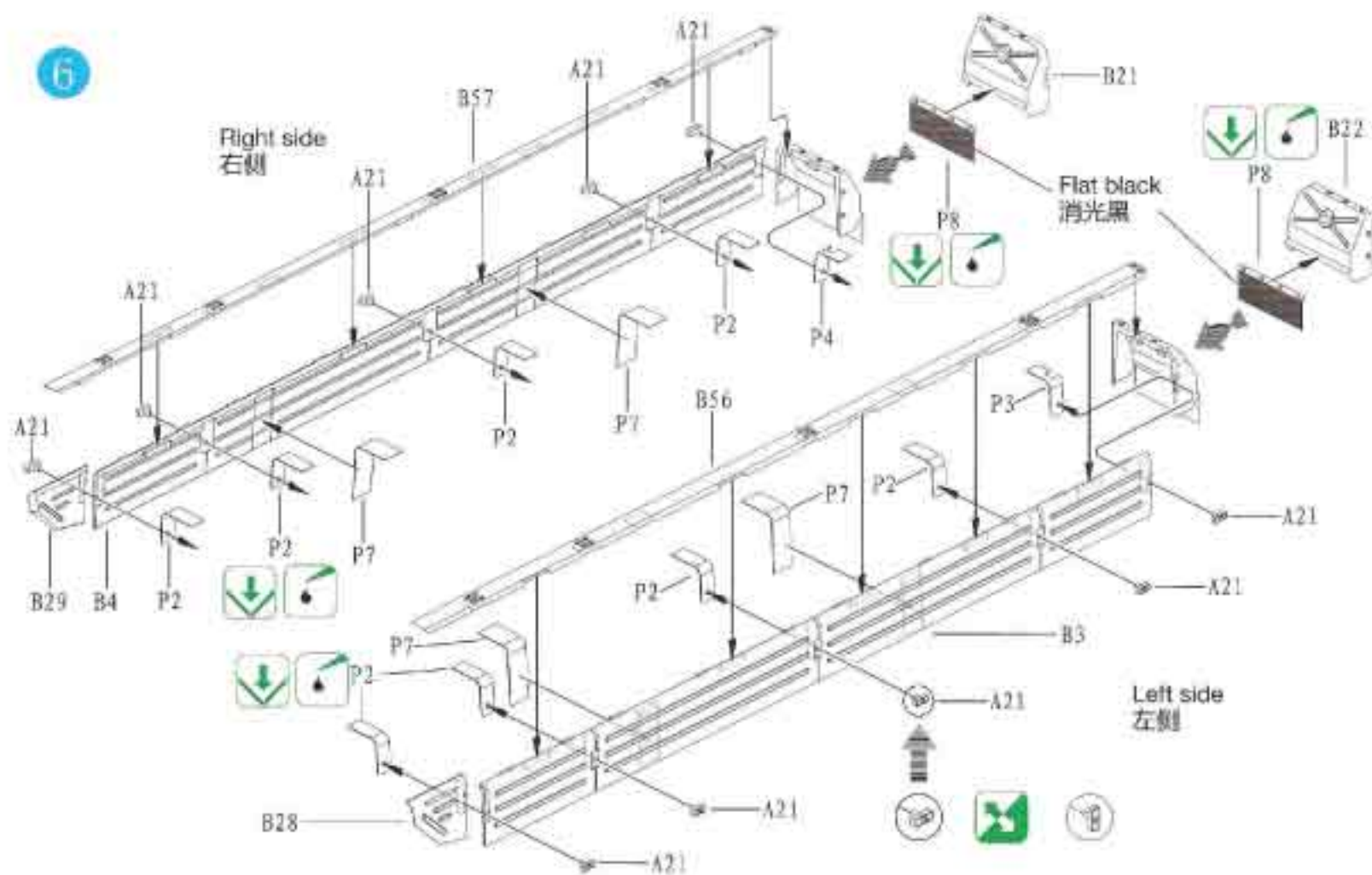
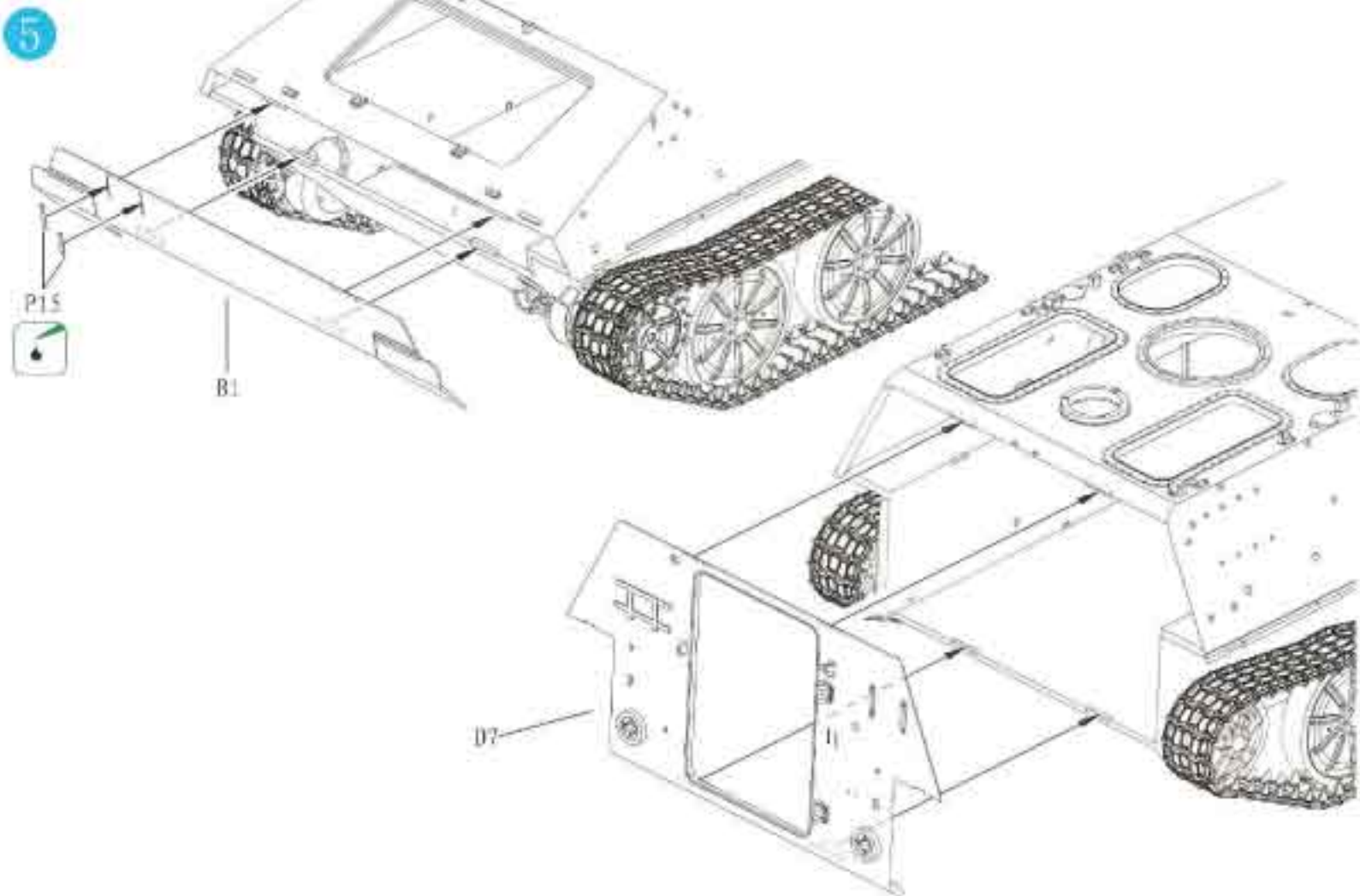
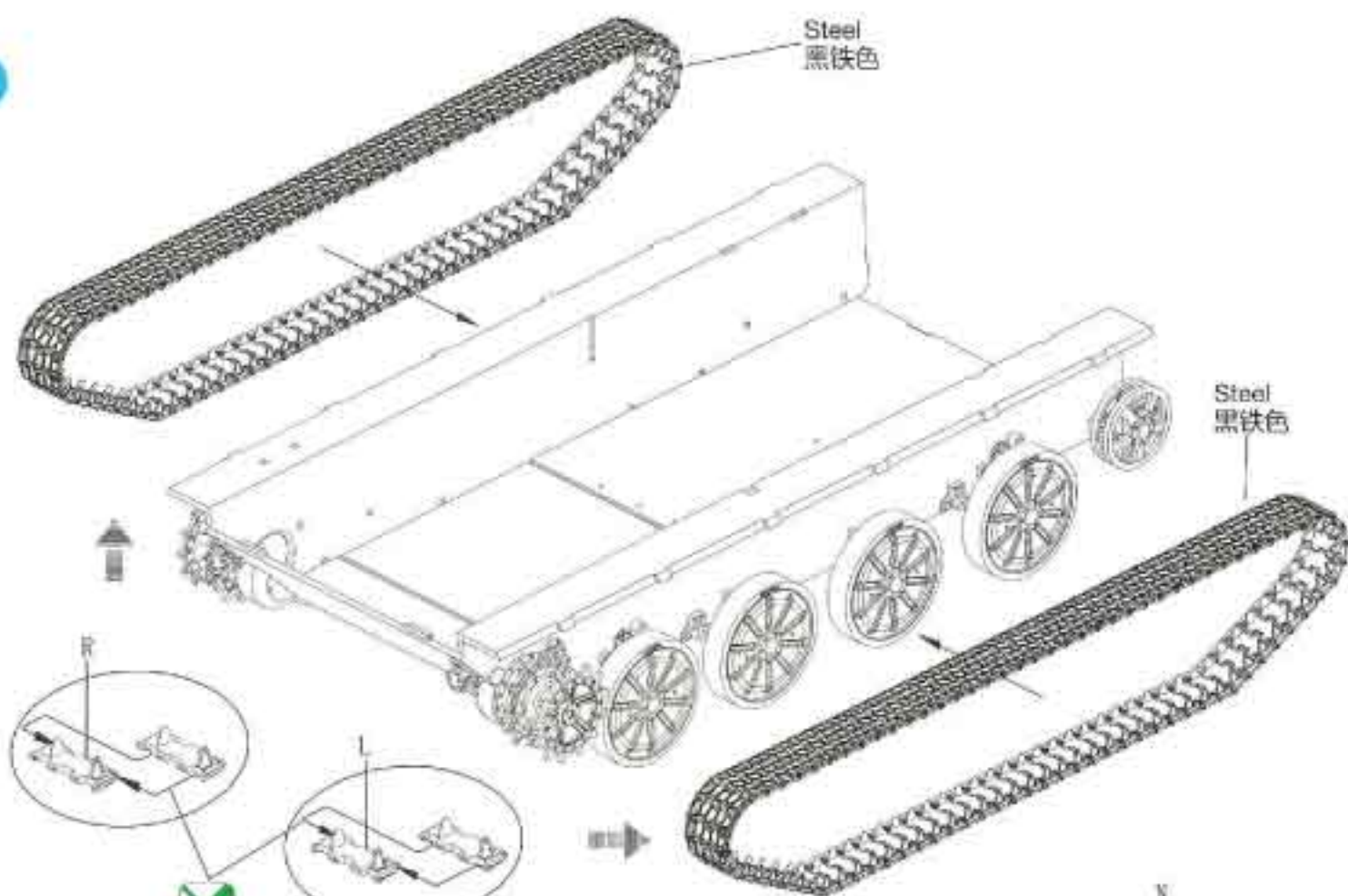

ILLUSTRATION 图示说明:



3



No cement
不用粘合

4

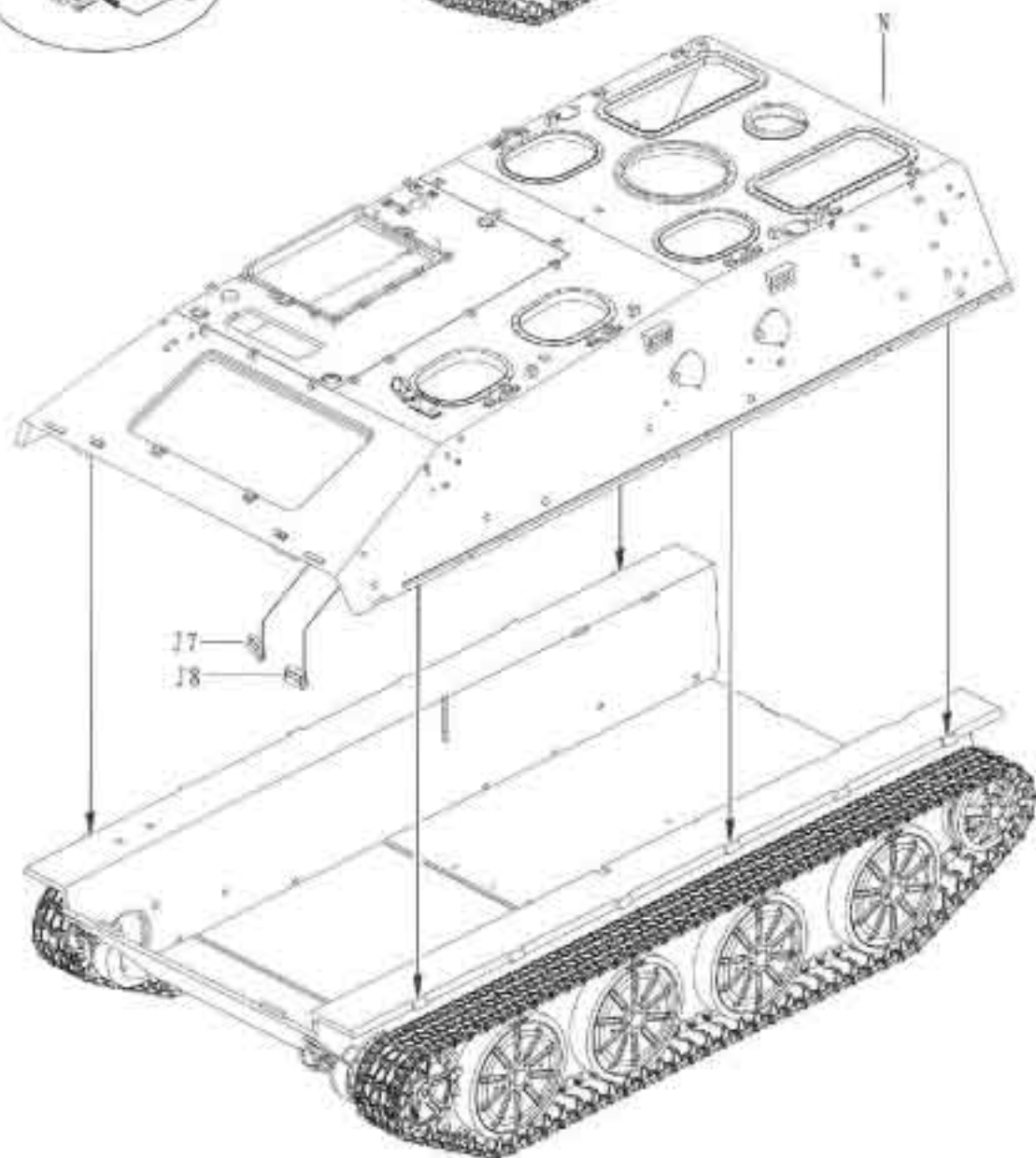
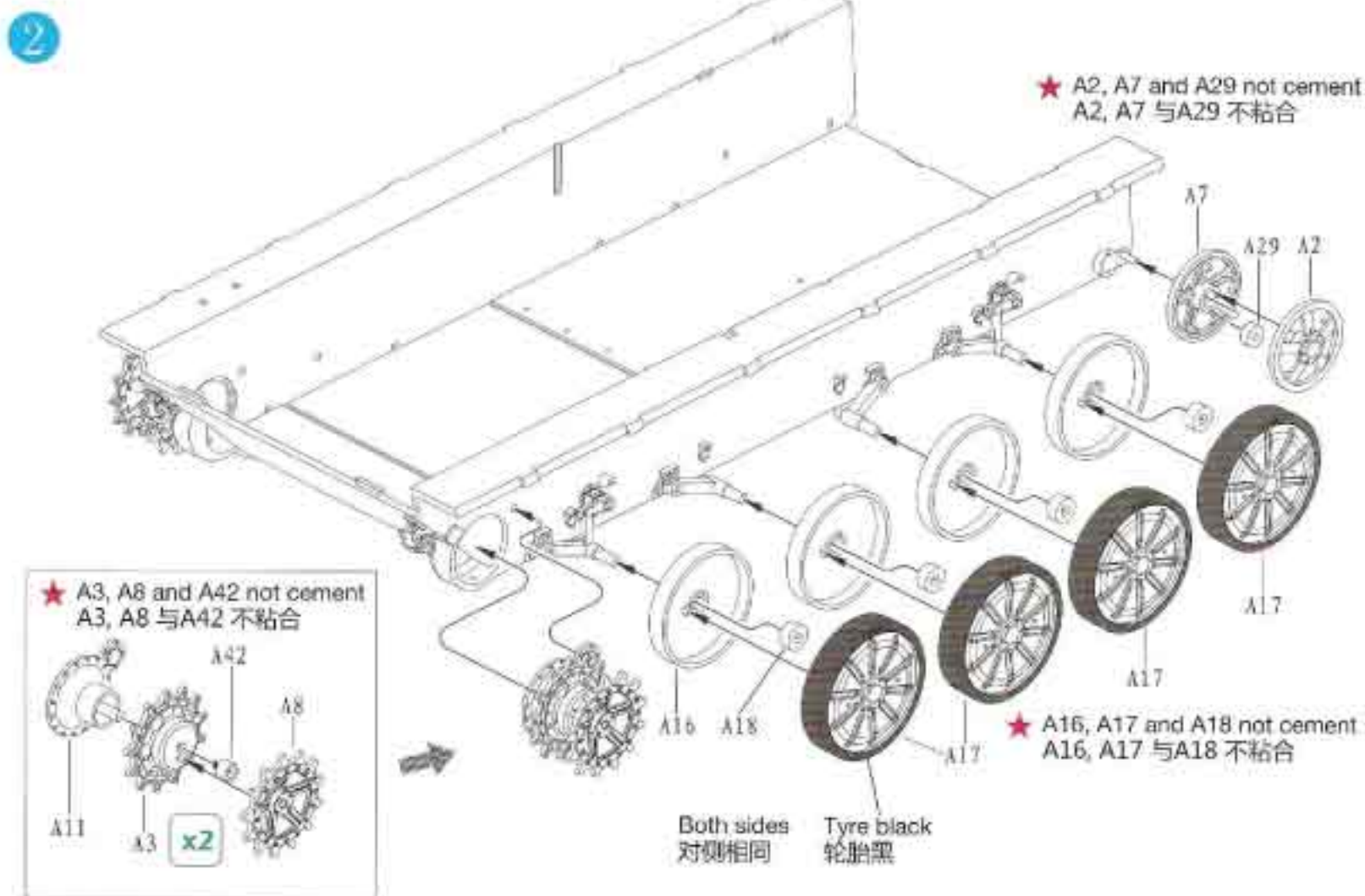
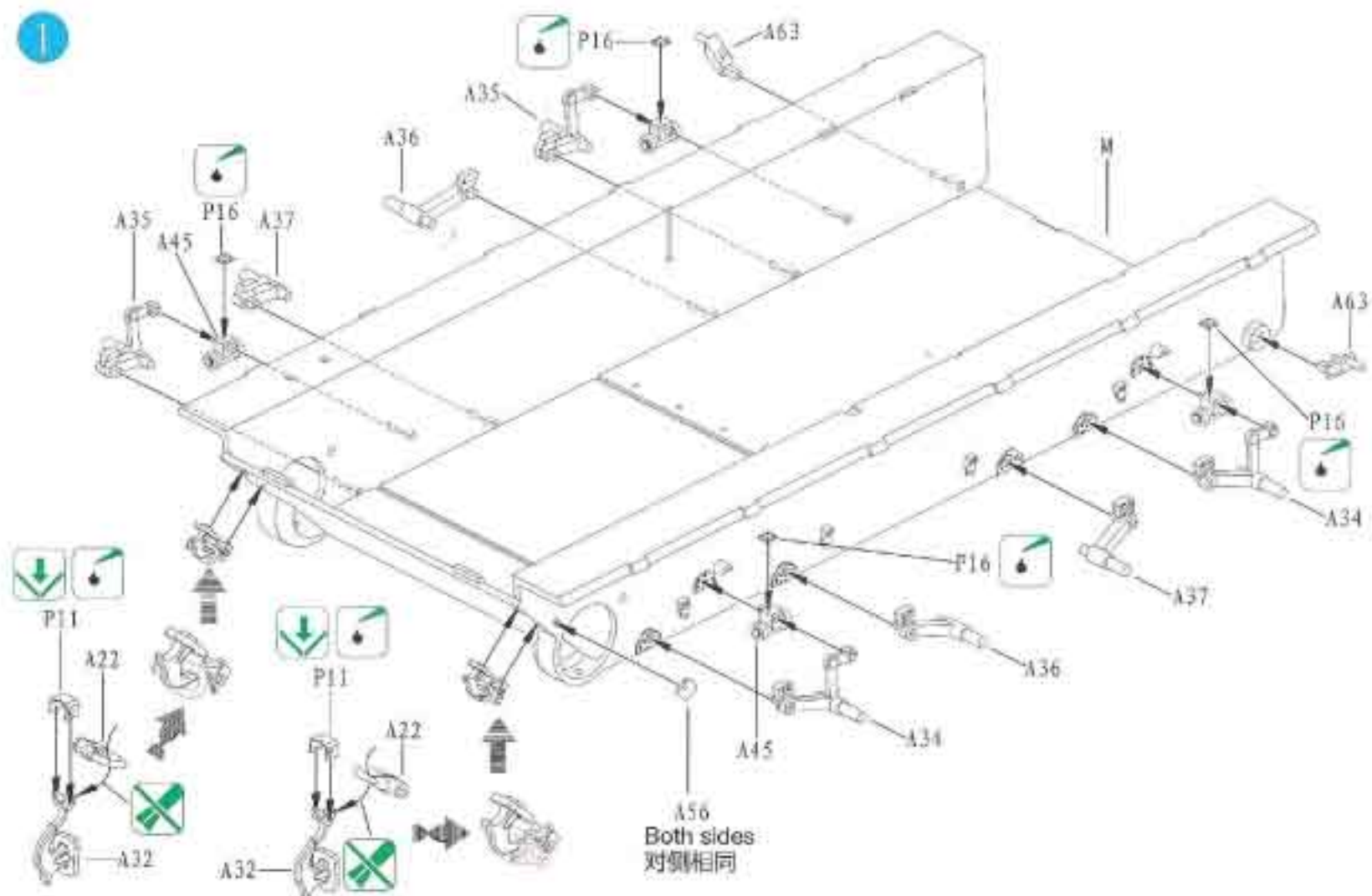

ILLUSTRATION 图示说明:





BRONCO

Bronco Models

Copyright © 2010

Made in China

中国制造



No use parts
不要部件

① × 1

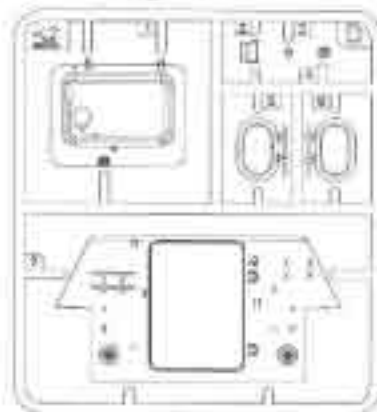

② × 1

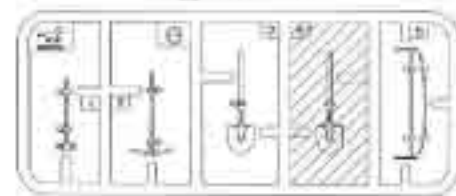

③ × 1

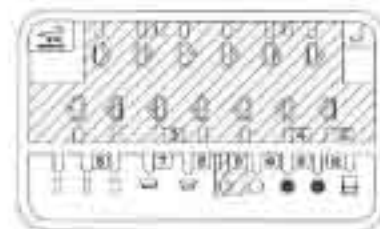

④ × 2

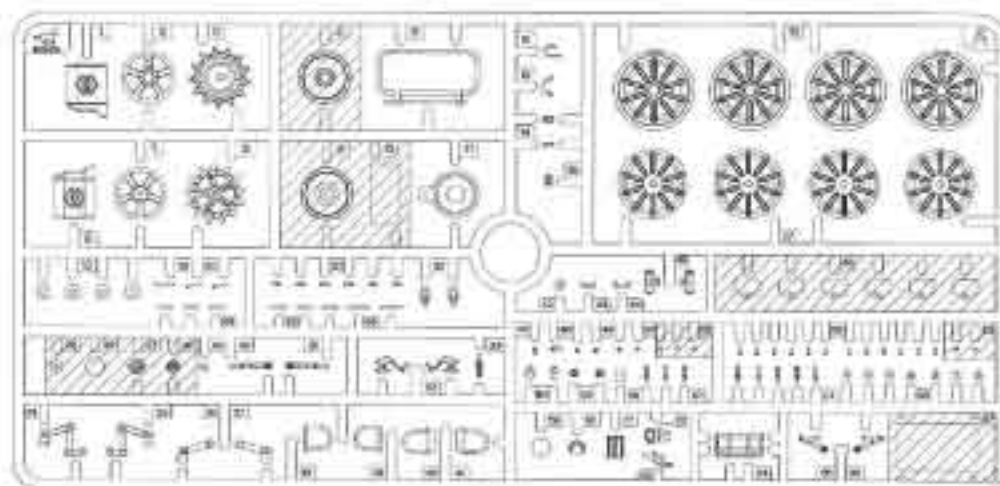

⑤ × 1

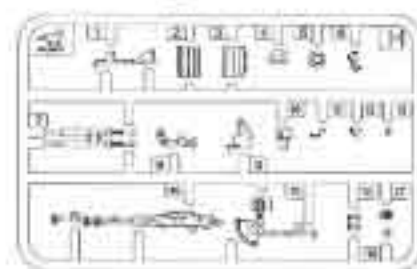

⑥ × 1

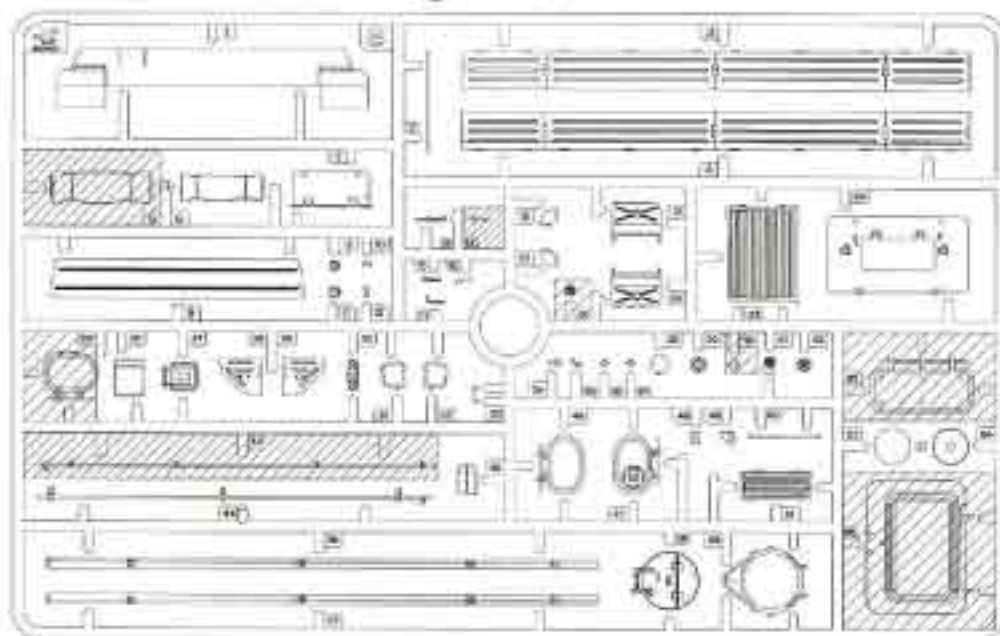

⑦ × 1

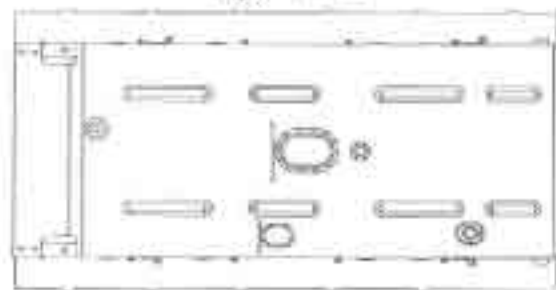

⑧ × 1

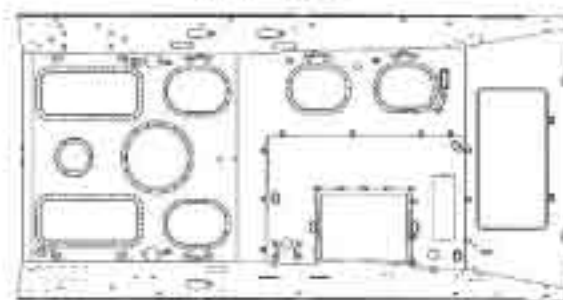

⑨ × 8

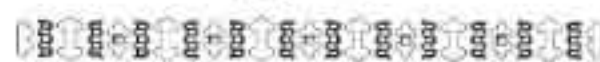

DECAL × 1



⑩ × 1

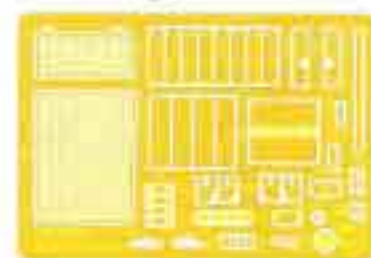

⑪ × 8

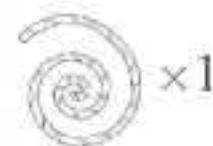
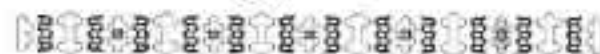

CB-35082

ILLUSTRATION 图示说明:

CORRECT METHOD FOR APPLYING DECALS 正确使用水贴纸的方法:

1. Clean model parts surface with wet cloth. Entsprechende Stellen am Modell feucht reinigen.
将需要贴水贴之部位表面擦干净。
2. Cut out the decal parts and dip them in cold water for 15 - 20 seconds. Decal ausschneiden und für 15-20 Sek. ins Wasser legen.
将所需之贴纸剪下泡在清水里约15至20秒。
3. Place it on correct position of the model kit. Decal an der richtigen Stelle auflegen.
将湿透之贴纸取出置放于正确之位置旁。
4. Slide off the decal from the base paper on to the model kit surface with a cotton stick. Decal mit Wattestäbchen festhalten und Papier darunter wegziehen.
用棉花棒轻推贴纸表面使其从底纸滑出至模型表面之正确位置。
5. When decal get dry then complete. Decal mit Papiertuch andrücken und trocknen.
待其自然干透后即完成。

ICON INSTRUCTION: 图标说明:



Open Hole
Loch bohren
钻孔



Remove
Abtrennen
切除



2 Sets needed
Vorgang wiederholen
同样的制作二组



Bend
Biegen
曲折



Optional
Auswahl
可以选择采用



Apply Decal
Decal anbringen
贴水贴纸



Instant Glue For Metal
Sekundenkleber verwenden
瞬间接着剂,金属用



Fill Hole
Verspachteln
把孔填平



Do not cement
Nicht kleben
不用粘合

COLOR SUGGESTION: FARBTABELLE 塗料建議

| Color 塗料表 | MR. Hobby | Hobby Color | Humbrol | Tamiya |
|--|-----------|-------------|---------|--------|
| Steel Stahl 黑铁色 | H-18 | C-28 | 53 | / |
| Khaki Kaki 卡其色 | H-81 | C-55 | 26 | XF-49 |
| Silver Silber 银色 | H-8 | J-8 | 11 | X-11 |
| Flat white Matt Weiss 消光白 | H-11 | C-62 | 34 | XF-2 |
| Light sand Hell-Sandfarben 浅沙色 | / | / | / | TS-46 |
| Dark green Dunkelgrün 深绿色 | H-36 | C-17 | 30 | XF-61 |
| Tyre black Reifenschwarz 轮胎黑 | H-77 | C-137 | 85 | / |
| Semi-gloss black Schwarz Seidenmatt 半光黑色 | / | C-82 | / | / |
| Wood brown Holzbraun 木啡色 | H-37 | C-43 | / | / |
| Flat black Mattschwarz 消光黑 | H-12 | C-33 | 33 | XF-1 |
| Gun metal Metall-grau 枪金属 | / | / | / | X-10 |

READ BEFORE ASSEMBLING: VOR ZUSAMMENBAU LESEN: 组装必读:

- Carefully Study instruction before assembling. Anleitung studieren und verständlich machen. 组装前请阅读清楚制作指引。
- Keep plastic model glue and tools away from children. Kleber, Farben, Werkzeuge und Plastikteilen von Kindern fernhalten. 胶水、油漆及工具勿让小孩接触。
- Do not use cement or paint near open flames or sparks. Kleber/Farbe nicht in Nähe von offenen Flammen. 胶水及油漆勿接触火种。
- Do not work in closed room. Nur in ausreichend belüfteten Räumen arbeiten. 勿在密闭地方制作模型。