

# BOEING 727 STRETCH

**mpc**  
78-4704-250





The Boeing 727 has become the best selling tri-jet in the world with more than 1,800 ordered or in service. The original short fuselage version first entered service on 1st February 1964 and like so many other types of airliners of the early 1960's, the 727 employed a rear mounted arrangement for its jet engines. This reduced cabin noise and gave a greater flexibility on power. The only version of the 727 currently available is the advanced model of the lengthened 727-200. Specifically designed for short, segmented air routes the 727-200 is 20 feet longer than the original 100 version, and can carry a maximum of 178 passengers. The first order for this version was placed by Northeast Airlines in August 1965 and since then it has entered widespread service with many of the major airlines of the world. The version depicted in this kit is of one flown by American Airlines. The Boeing 727-200 is powered by three Pratt and Whitney JT8D-7 turbo fan engines giving a maximum cruising speed of 549 knots (630 mph) at 21,604 ft., wing span is 108 ft. and length 153 ft.

## IMPORTANT! READ THIS FIRST

- Study assembly drawings carefully before starting.
- Each part is identified by a part number (14).
- Scrape paint from areas to be cemented.
- Before cement is used, check the fit of each part.
- Use only enough cement to join parts.
- Apply cement to small parts with a toothpick.
- Use cement made for styrene plastic only.
- Allow paint to dry thoroughly before handling.
- Your model may be painted to match the box photos.
- Cement all parts except where Do Not Cement symbol  is shown.
- Follow the step numbers ⑤ in each assembly drawing.
- ★ Refer to other assembly drawing for location.
- Refer to last page for decal and painting instructions.

© 1983 Fundimensions, Division of CPG Products Corp.

## 1/144 SCALE

- ⑤ ——— STEP NUMBERS
- 32 ——— PLASTIC PART NUMBERS
-  ——— OPTIONAL
-  ——— DO NOT CEMENT
-  ——— CEMENT HERE ONLY
- 2X ——— REPEAT SEVERAL TIMES
-  ——— REMOVE
- ★ ——— REFER TO ....
-  ——— DECAL

1 Refer to last page for painting instructions before proceeding.

1 NOTE: If aircraft is to stand on the landing gear, weight nose with modeling clay before assembling fuselage.

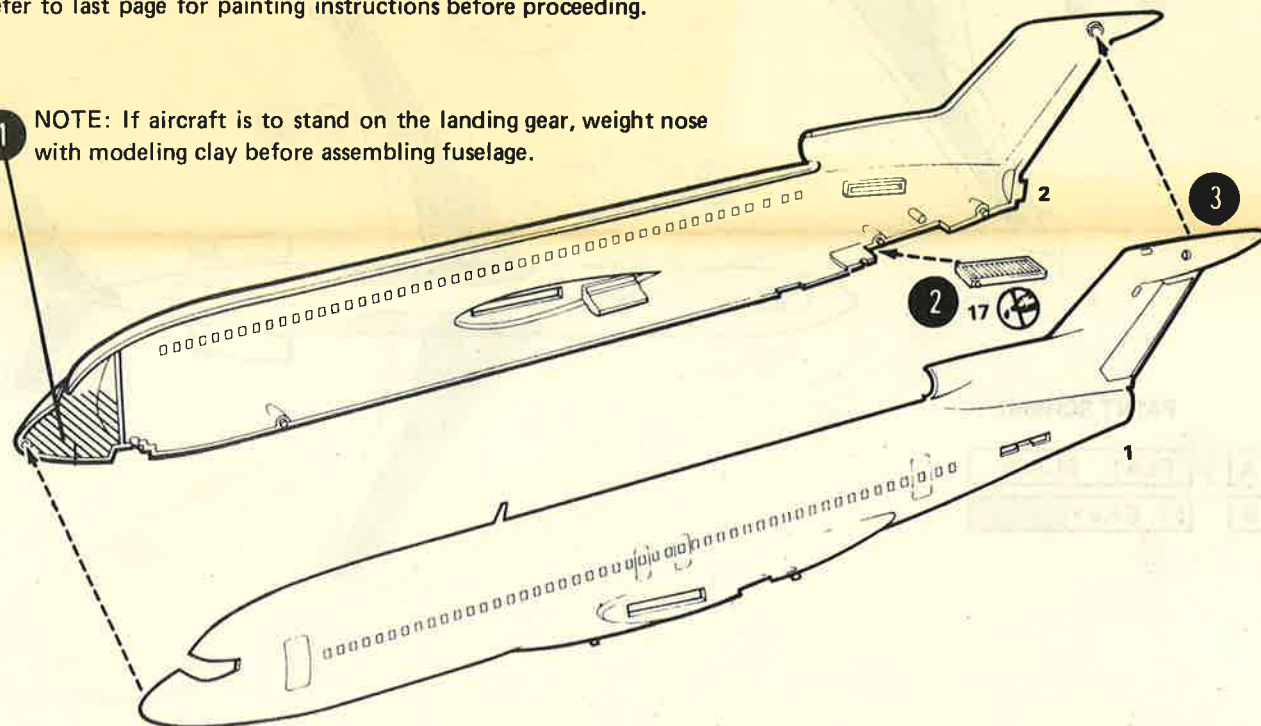

# 2

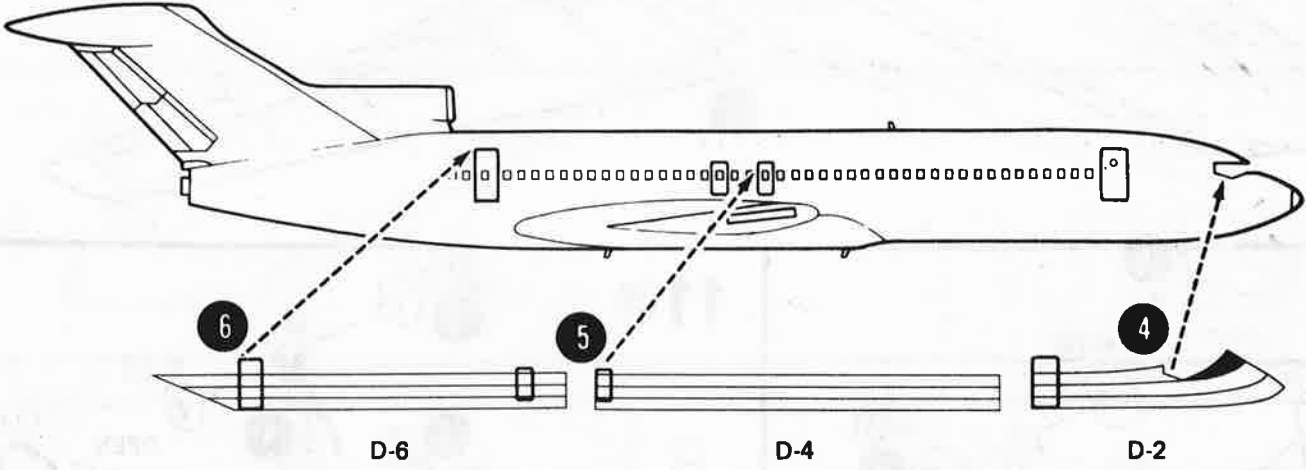
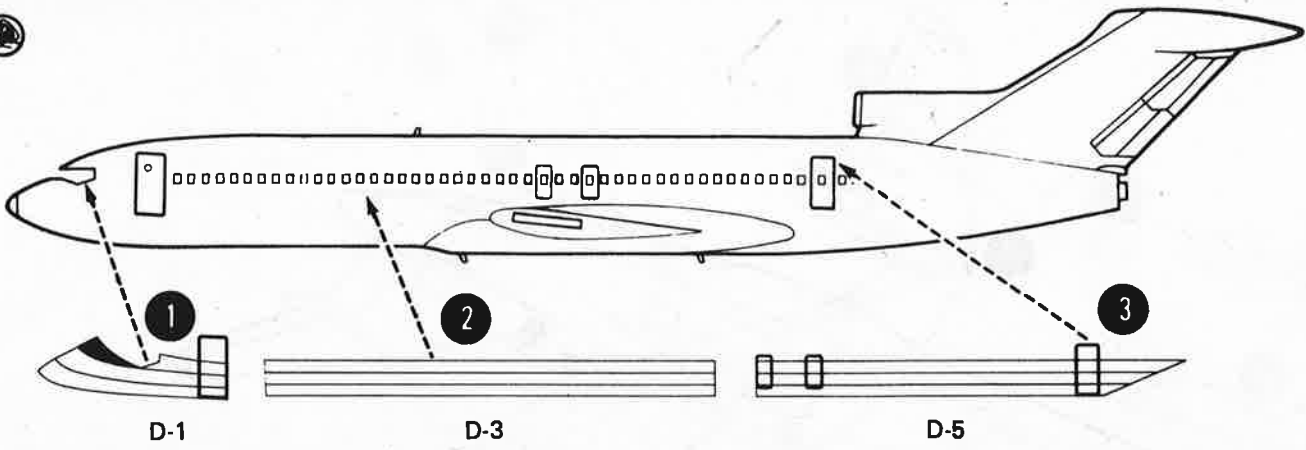

# 3

After applying decal and decal has dried, use part no. 6 to pierce the windows.

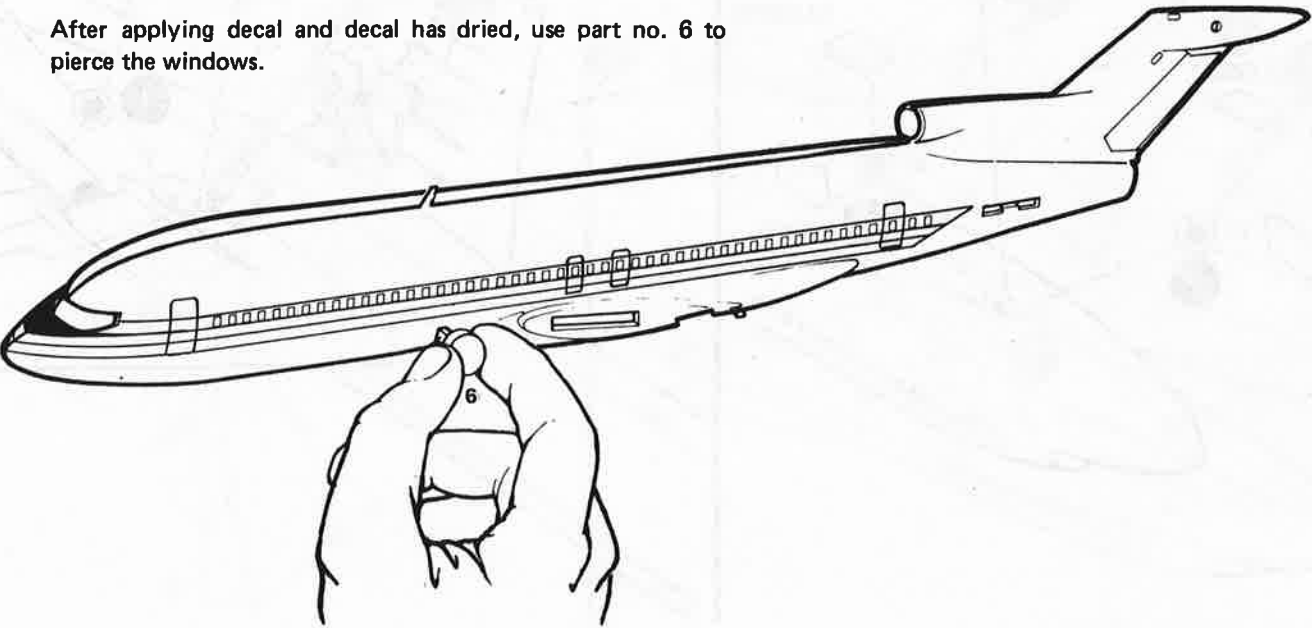

4

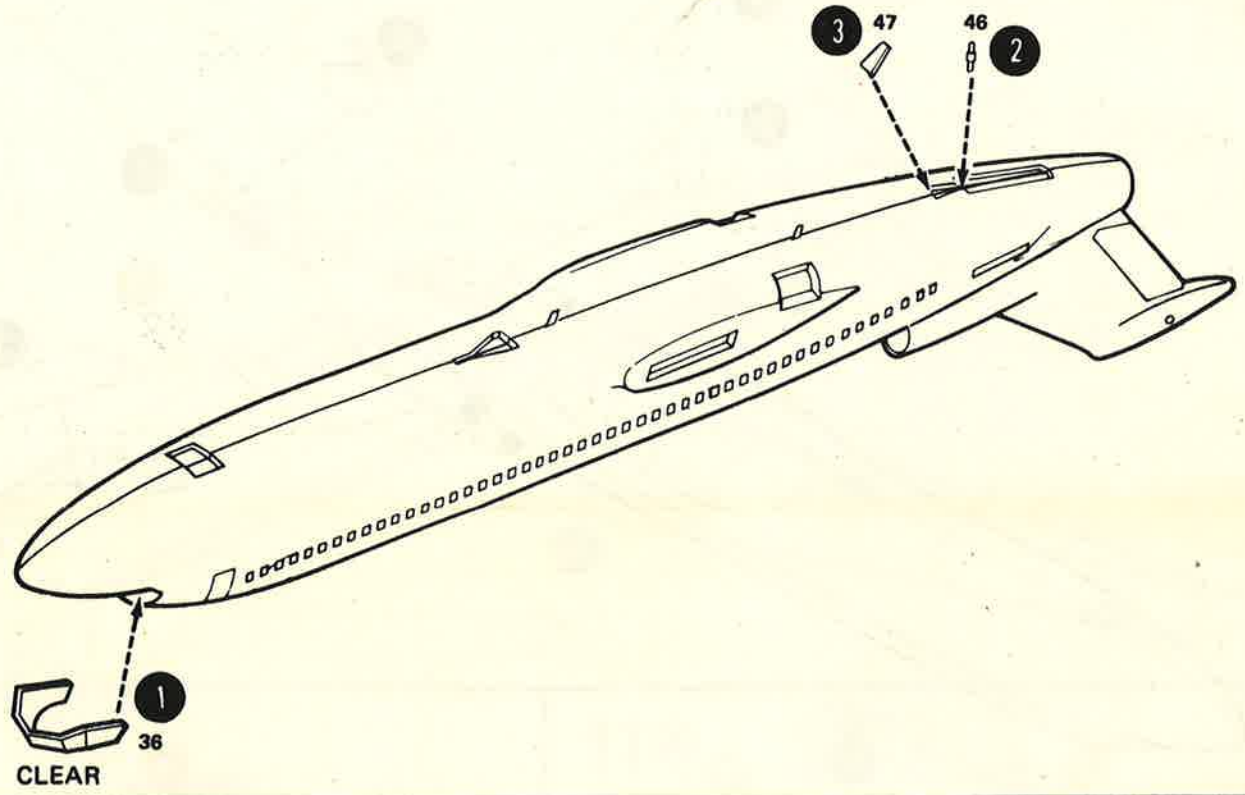

5

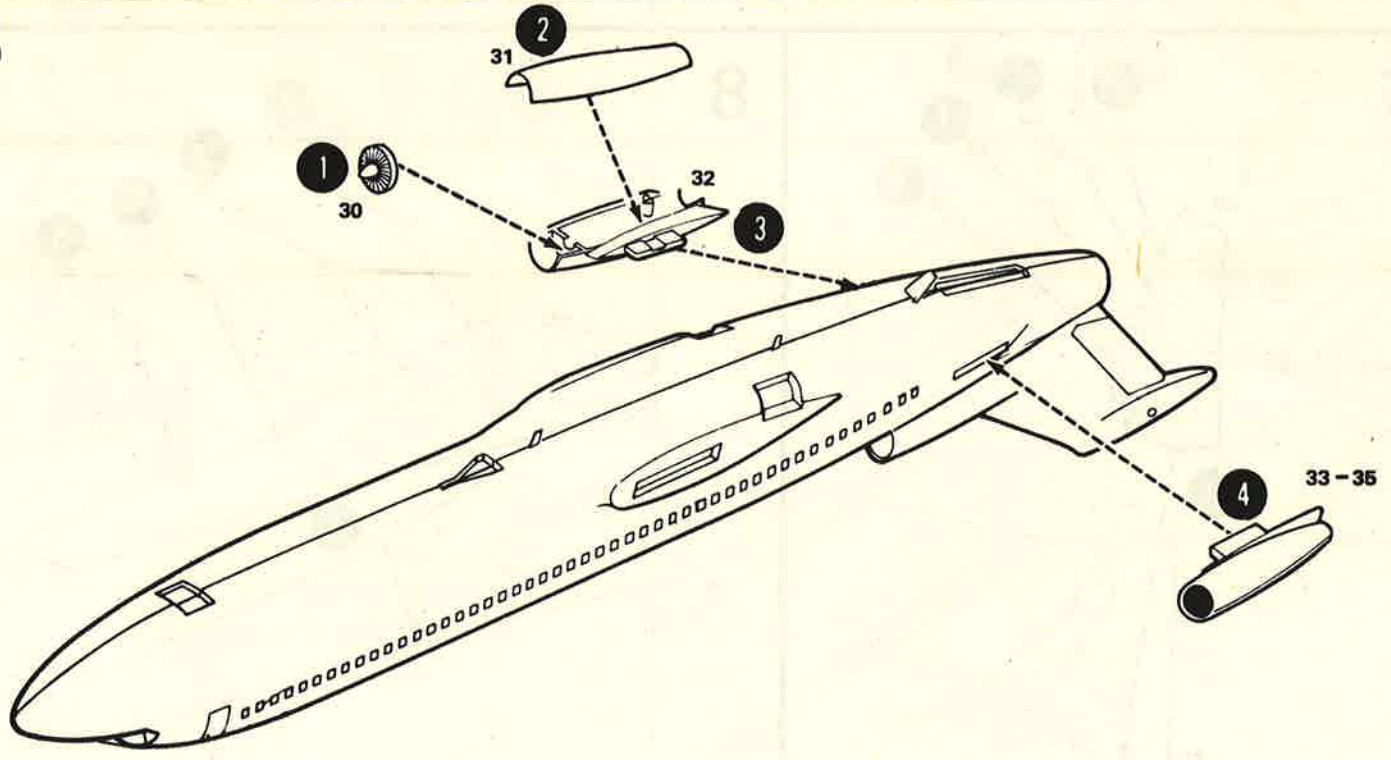

6

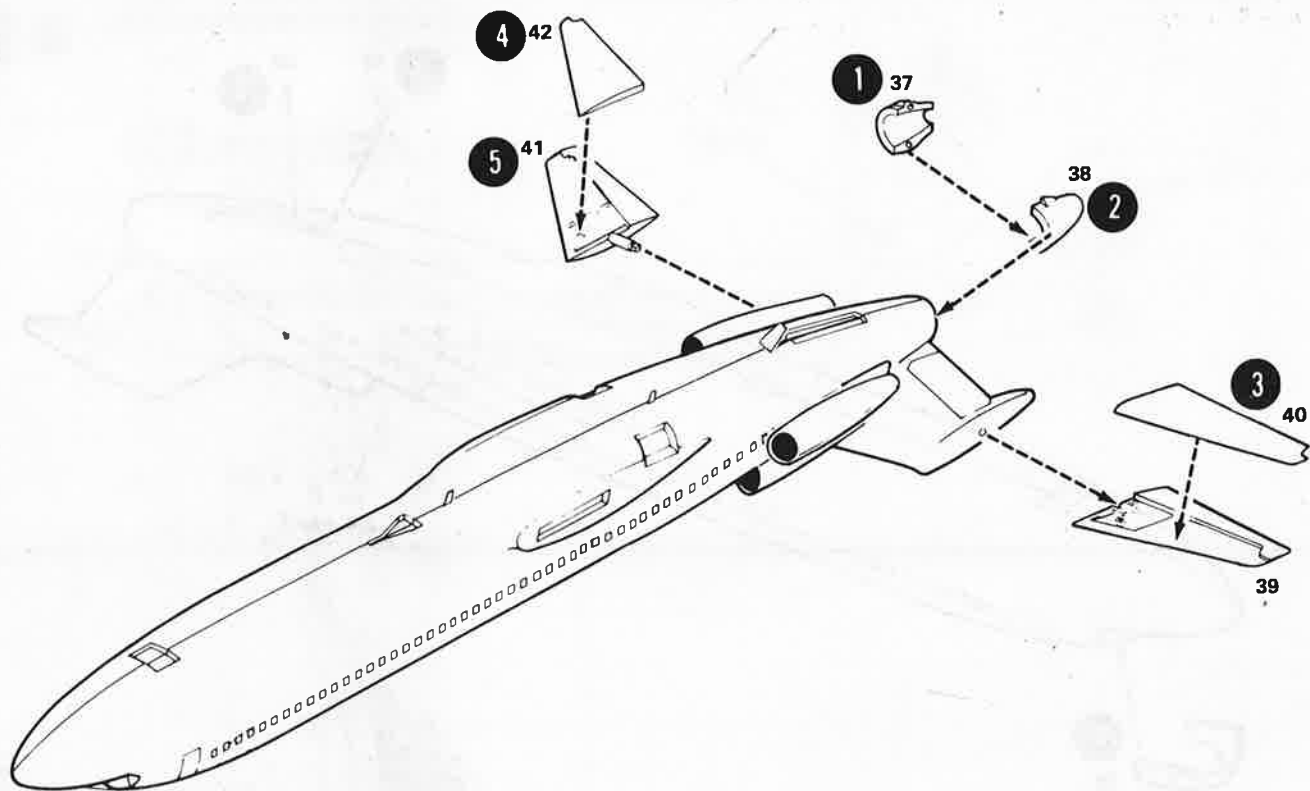

7

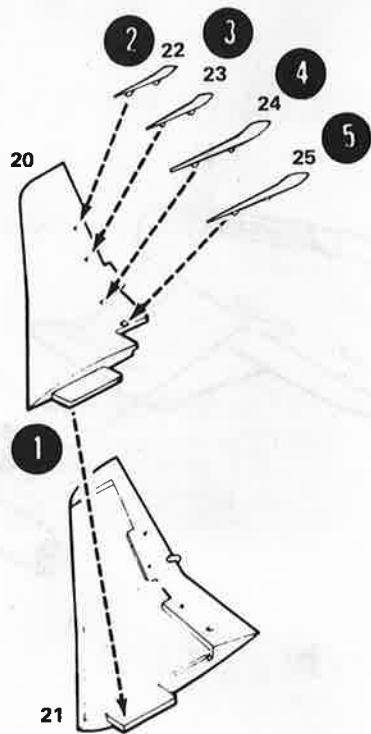

8

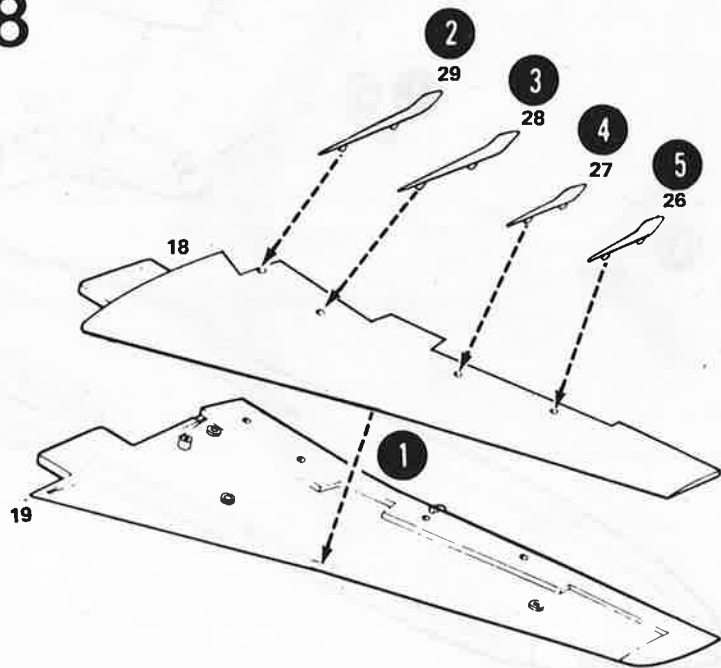

9

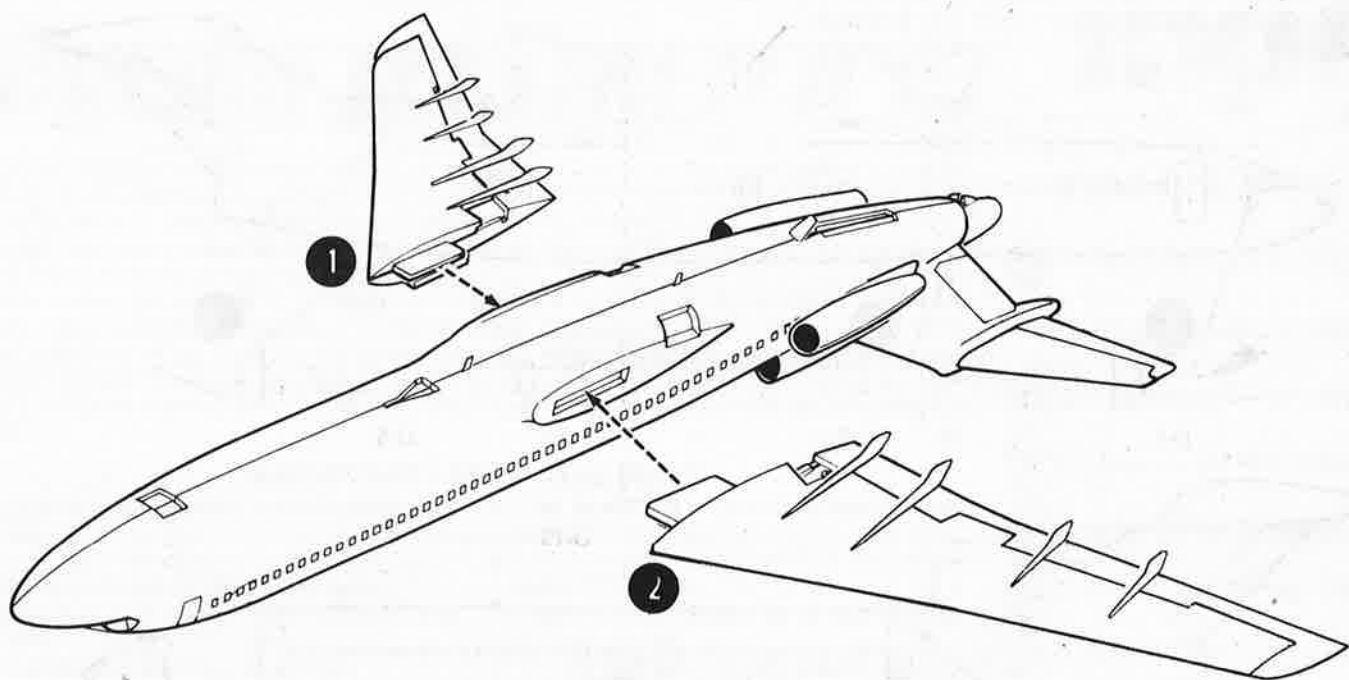

10

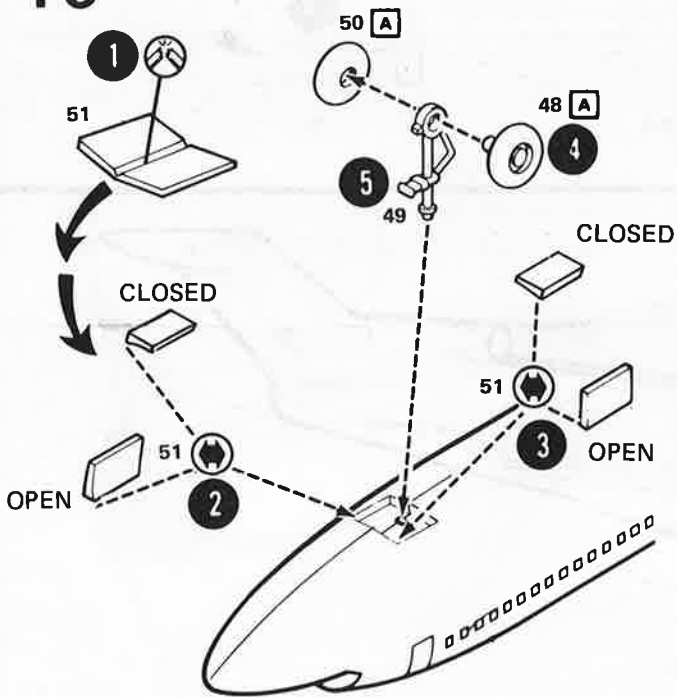

11 (2X)

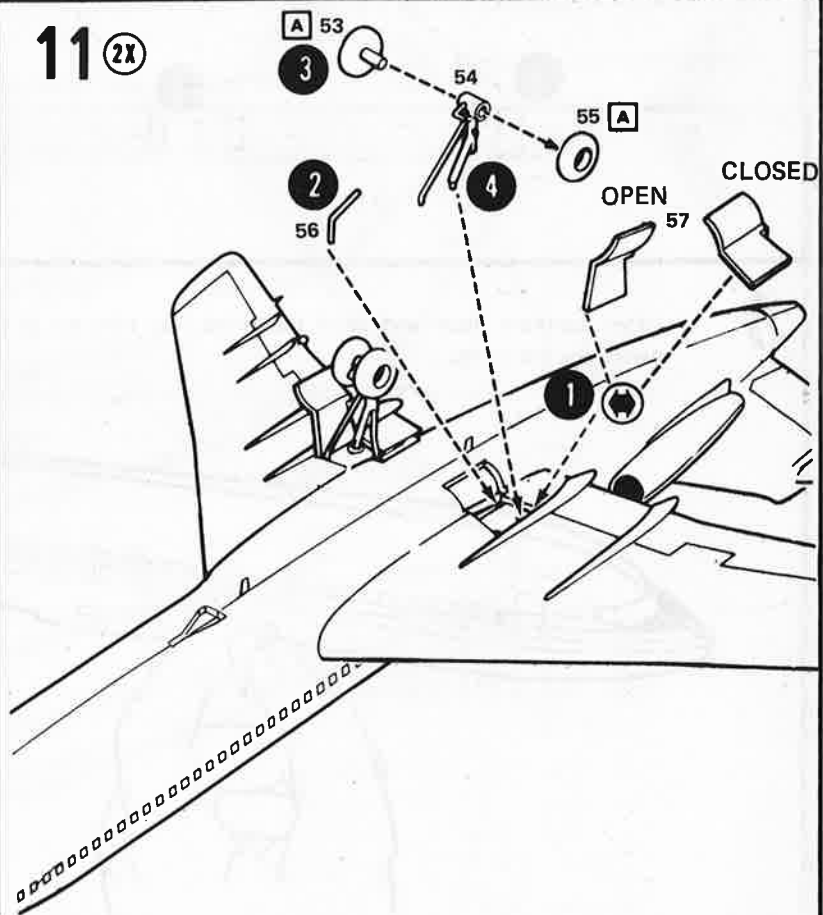

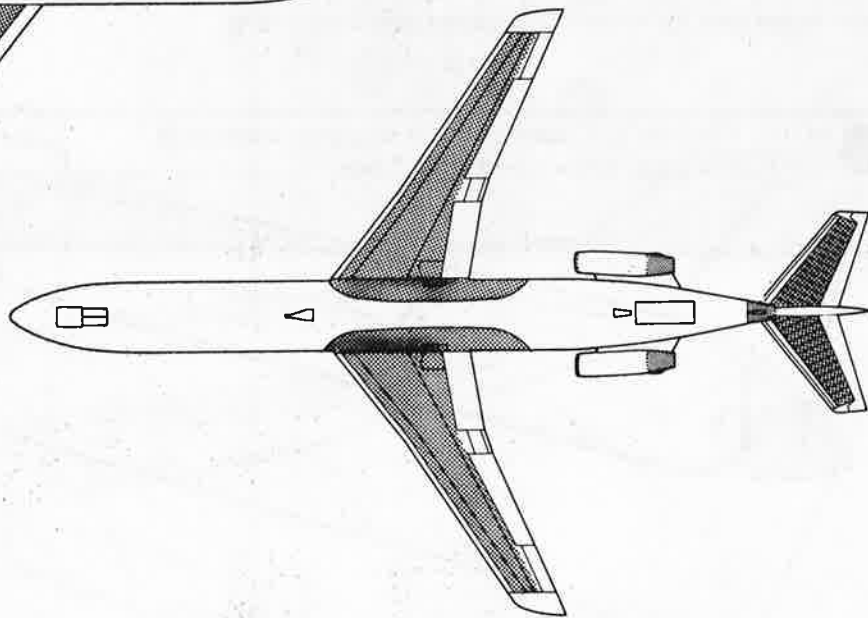
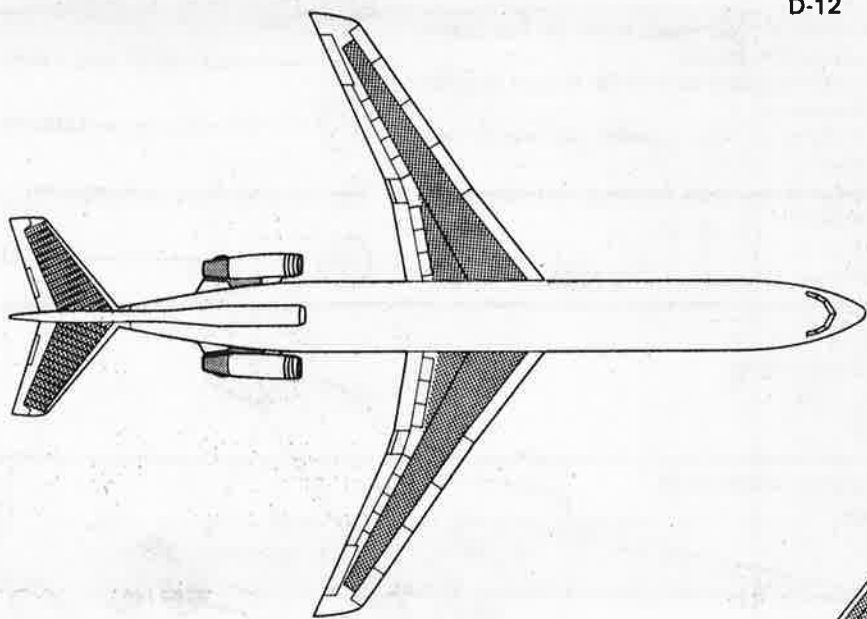
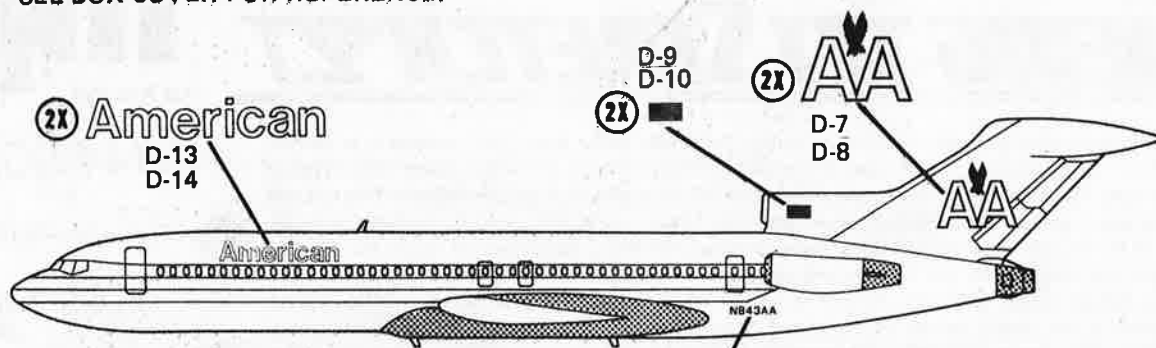

## PAINT SCHEME

A	FLAT BLACK
B	LT. GREY