

The Grumman F-14A Tomcat is the workhorse of the United States Navy's fighter aircraft inventory. Mounting an AWG-9 weapons control system, it can lock onto and track as many as 24 targets up to about 166 kilometers away, and fire an AIM-54 Phoenix missile (with a maximum range of 185 kilometers) at any six of them individually. The AWG-9 is also capable of simultaneous, multiple targeting during air-to-air combat when tracking is impossible. Another feature characteristic is the utilization of variable geometry wings. The Mach sweep program computer on board the aircraft maintains the variable sweep angle of the main wings at the optimum lift drag ratio at all times. While being stored or serviced on the deck of the aircraft carrier, the wings may be swept back to a full 75 degrees to facilitate space-saving on a narrow deck. The F-14A Plus mounts the General Electric F-110-GE-400 engine for better performance. As a result of the engine change, the exhaust nozzle also had to undergo major design changes.

« Data » Crew:2 Wing span:19.54m Length:18.9m Height:4.88m
Powerplant:GE/F-110-GE-400 Fixed armament:M61A1 20mm vulcan cannon
First flight:September 29, 1986

グラマンF-14A トムキャットは、アメリカ海軍の主力艦上戦闘機です。F-14はAWG-9火器管制システムを搭載して、約166km先の目標を捕捉し、最大24目標を追尾することができます。しかも、その内6機を個別にAIM-54フェニックスミサイル(最大射程約185km)で、同時攻撃が行えるという他の追従を許さない多目標同時処理能力をもっています。もう一つの特徴は、可変後退翼を採用していることです。この可変翼は、マッハ・スウィープ・プログラム・コンピュータによって常に最適の揚抗比が得られるように主翼の後退角を変化させます。また、格納用の後退角では75°になり、空母甲板上での取り回しを容易にしています。F-14Aプラスは、エンジンをジェネラルエレクトリックF-110-GE-400に換装して性能向上が計られました。そのため、排気ノズルの形状が大きく変わりました。

《データ》乗員:2名、全幅:19.54m、全長:18.90m、全高:4.88m、エンジン:GE/F-110-GE-400、固定武装:M61A1 20mmバルカン砲×1、初飛行:1986.9.29

① 143 143

② 143 143

③ 143 143

④ 143 143

⑤ 143 143

⑥ 143 143

⑦ 143 143

⑧ 143 143

⑨ 143 143

⑩ 143 143

⑪ 143 143

⑫ 143 143

⑬ 143 143

⑭ 143 143

⑮ 143 143

⑯ 143 143

⑰ 143 143

⑱ 143 143

⑲ 143 143

⑳ 143 143

㉑ 143 143

㉒ 143 143

①(1)

② 101 101

③ 101 101

④ 101 101

⑤ 101 101

⑥ 101 101

⑦ 101 101

Pukin' Dogs

Pukin' Dogs

Pukin' Dogs

Pukin' Dogs

Pukin' Dogs

Pukin' Dogs

Pukin' Dogs

Pukin' Dogs

Pukin' Dogs

Pukin' Dogs

Pukin' Dogs

Pukin' Dogs

Pukin' Dogs

Pukin' Dogs

Pukin' Dogs

Pukin' Dogs

Pukin' Dogs

Pukin' Dogs

Pukin' Dogs

Pukin' Dogs

101 101

101 101

101 101

101 101

101 101

101 101

101 101

101 101

101 101

101 101

101 101

101 101

101 101

101 101

101 101

101 101

101 101

101 101

101 101

101 101

101 101

101 101

101 101

101 101

101 101

101 101

101 101

101 101

101 101

101 101

101 101

101 101

101 101

101 101

101 101

101 101

101 101

101 101

101 101

101 101

101 101

101 101

101 101

101 101

101 101

101 101

101 101

101 101

101 101

101 101

101 101

101 101

101 101

101 101

101 101

101 101

101 101

101 101

101 101

101 101

101 101

101 101

101 101

101 101

101 101

101 101

101 101

101 101

101 101

101 101

101 101

101 101

101 101

101 101

101 101

101 101

101 101

101 101

101 101

101 101

101 101

101 101

101 101

101 101

101 101

101 101

101 101

101 101

101 101

101 101

101 101

101 101

101 101

101 101

101 101

101 101

101 101

101 101

101 101

101 101

101 101

101 101

101 101

101 101

101 101

101 101

101 101

101 101

101 101

101 101

101 101

101 101

101 101

101 101

101 101

101 101

101 101

101 101

101 101

101 101

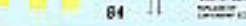
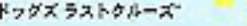
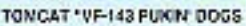
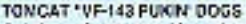
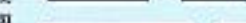

VF-143

VF-143

VF-143

VF-143

VF-143

VF-143

VF-143

VF-143

VF-143

VF-143

VF-143

VF-143

VF-143

VF-143

VF-143

143

143

143

143

143

143

143

143

143

143

143

143

143

143

143

143

143

143

143

143

143

143

143

143

143

143

143

143

143

143

143

143

143

143

143

143

143

143

143

143

143

143

143

143

143

143

143

143

143

143

143

143

143

143

143

143

143

143

143

143

143

143

143

143

143

143

F-14B TOMCAT 'VF-143 PUKIN' DOGS LAST CRUISE



06 01 1:72 F-14B トムキャット 'VF-143 ビューキンドッグズラストクルーズ'

Marking and Painting

マーキング 塗装指示

Marking and Painting

マーキングと塗装指示

Marking and Painting



アメリカ海軍 第143戦闘飛行隊 'ビューキンドッグズ' 特別塗装機
U.S. Navy VF-143 'Pukin' Dogs Special Painted Aircraft

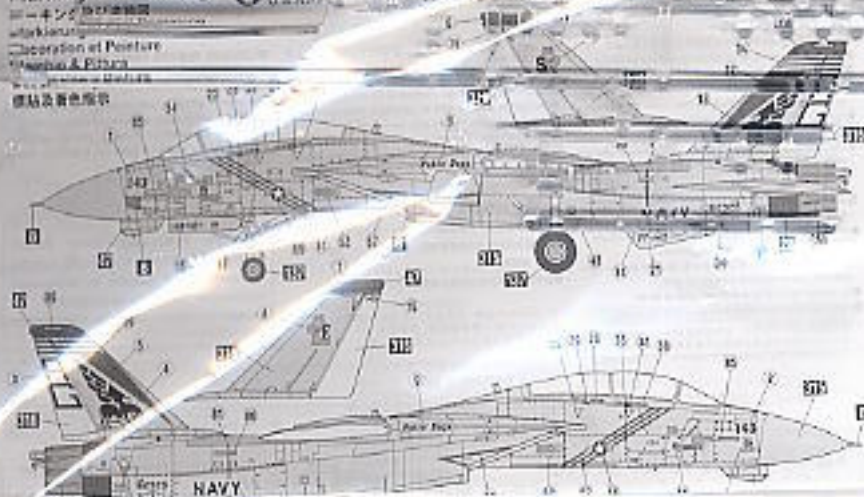

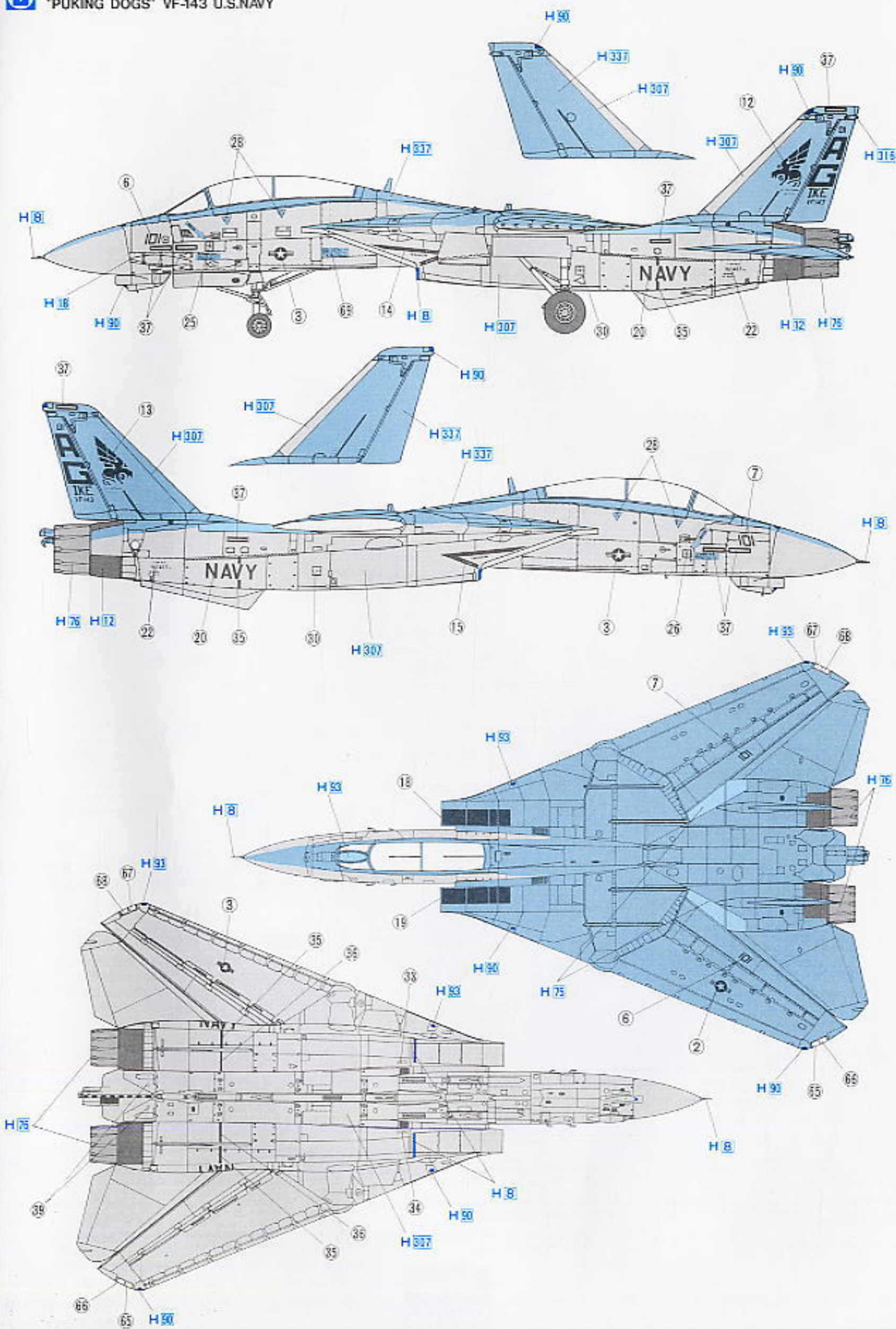

H	2	2	ブラック	BLACK
H	8	8	シルバー	SILVER
H	12	33	つや消しブラック	FLAT BLACK
H	18	28	黒鉄色	STEEL
H	75	25	ダークシーグレー	DARK SEA GRAY
H	76	61	焼鉄色	BURNT IRON
H	77		タイヤブラック	TIRE BLACK
H	81	55	カーキ	KHAKI
H	90	47	クリアーレッド	CLEAR RED
H	93	50	クリアーブルー	CLEAR BLUE
H	94		クリアーグリーン	CLEAR GREEN
H	305	305	グレー FS36118	DARK GRAY
H	307	307	グレー FS36320	GRAY
H	316	316	ホワイト FS17875	WHITE
H	317	317	グレー FS36231	GRAY
H	327	327	レッド FS11136	RED
H	329	329	イエロー FS13538	YELLOW
H	337	337	グレイッシュブルー FS35237	GRAYISH BLUE

1

x2

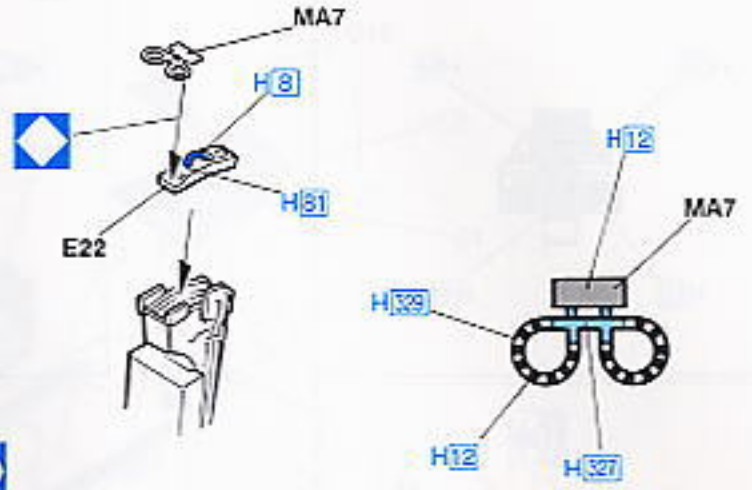
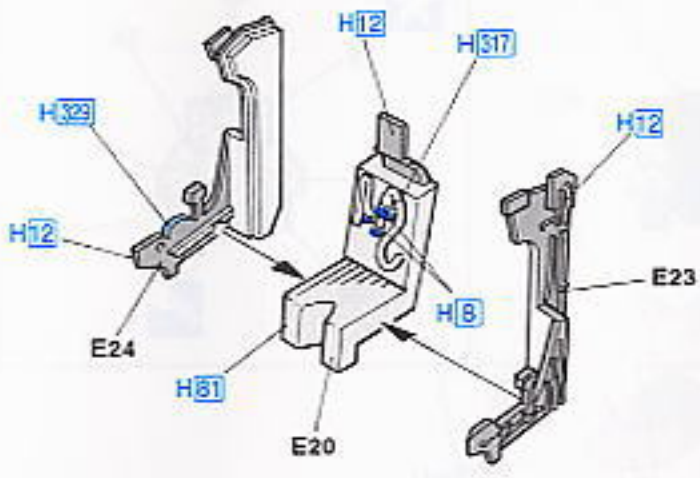

2

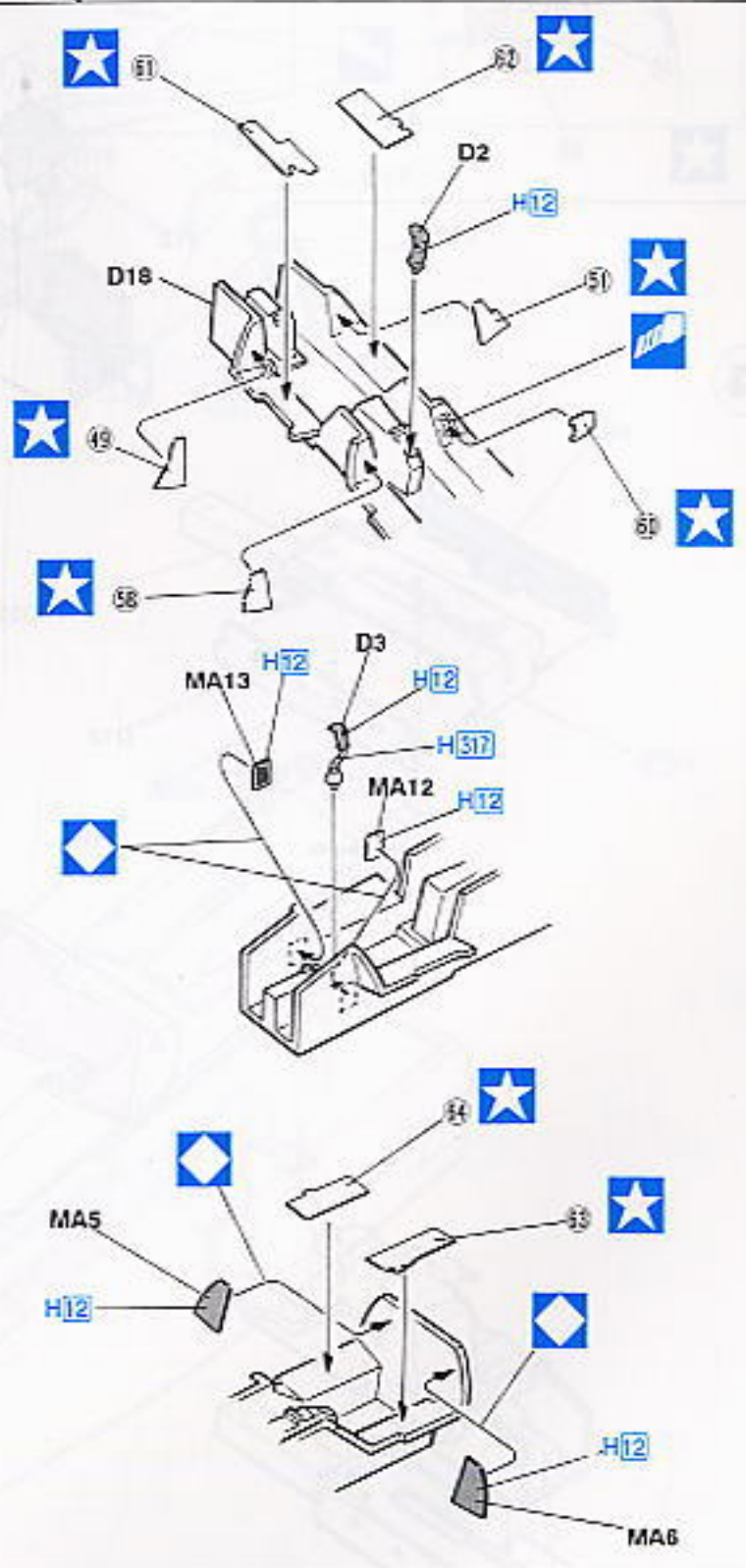
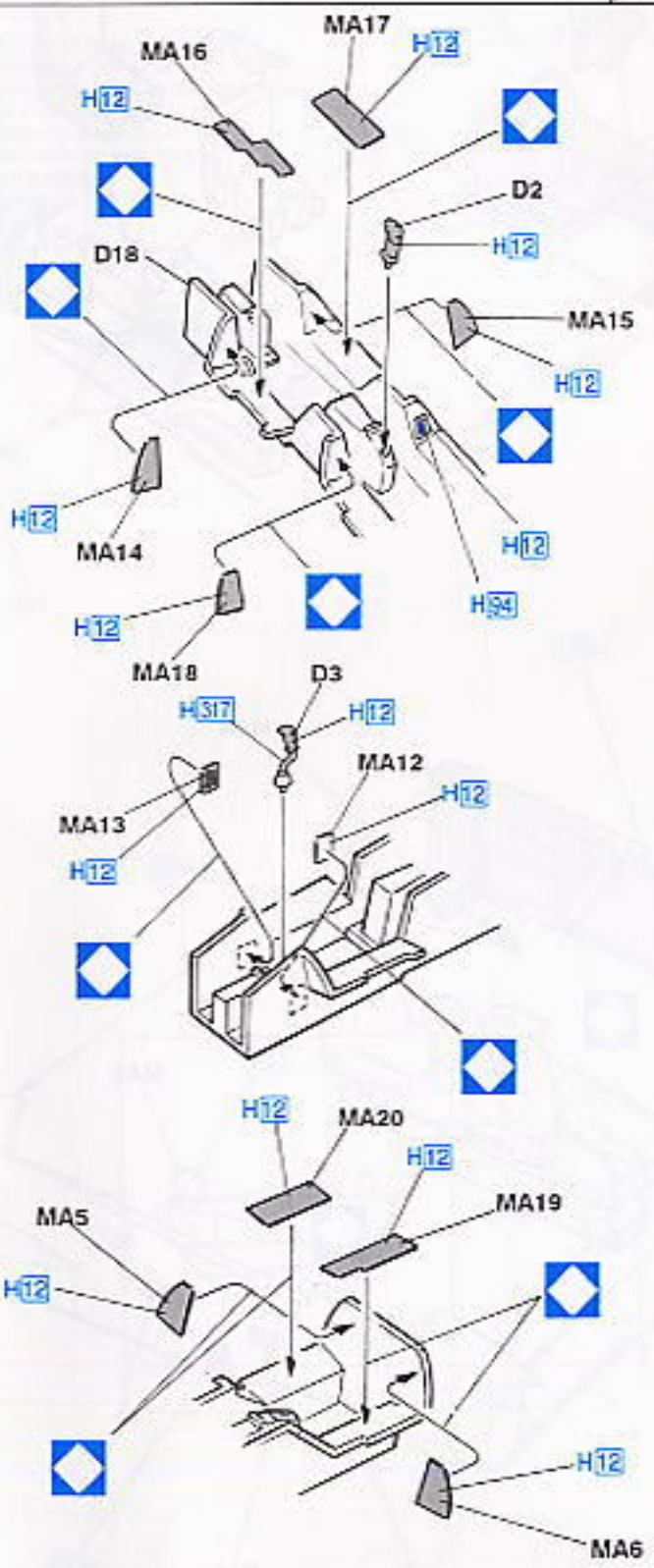

3

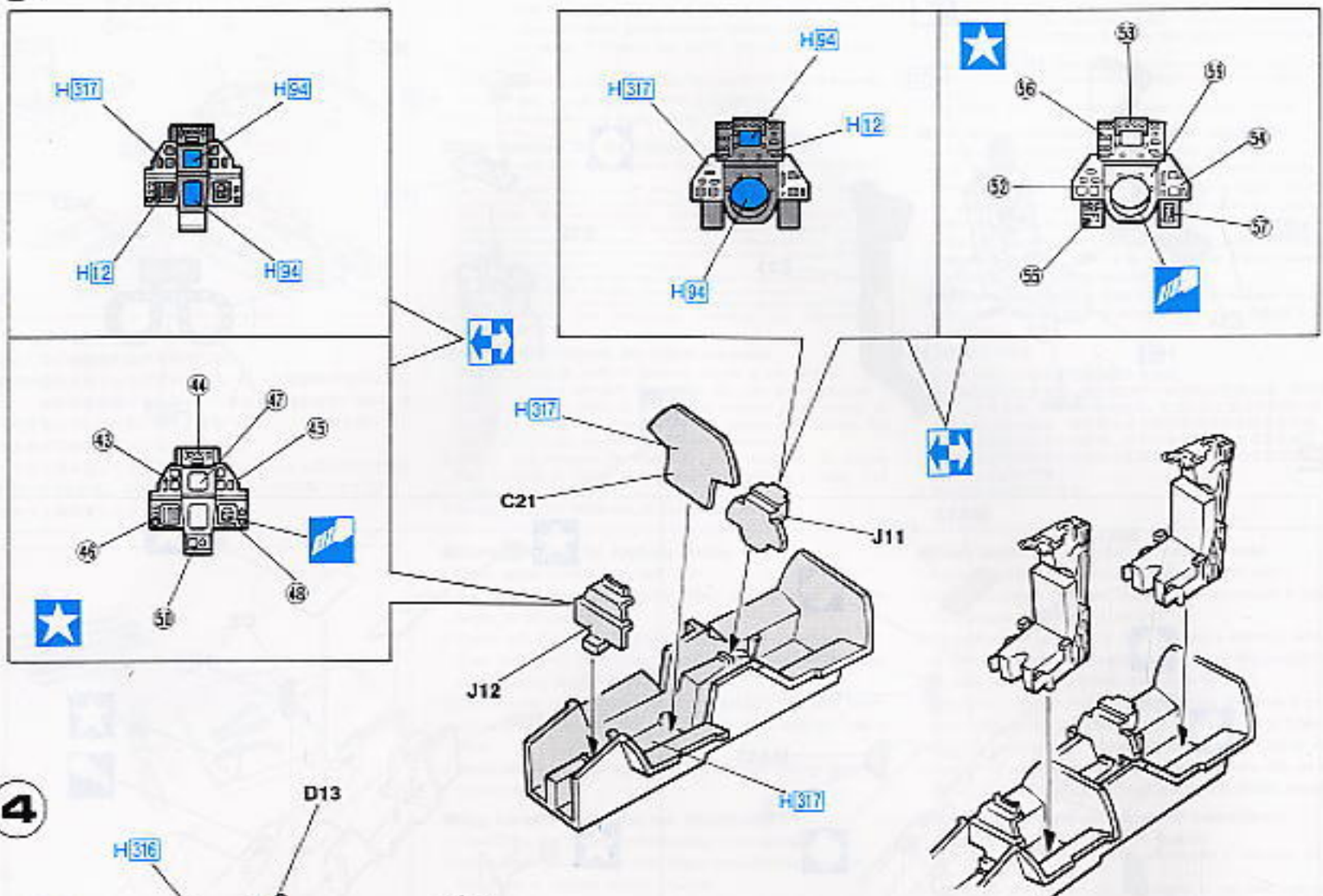

4

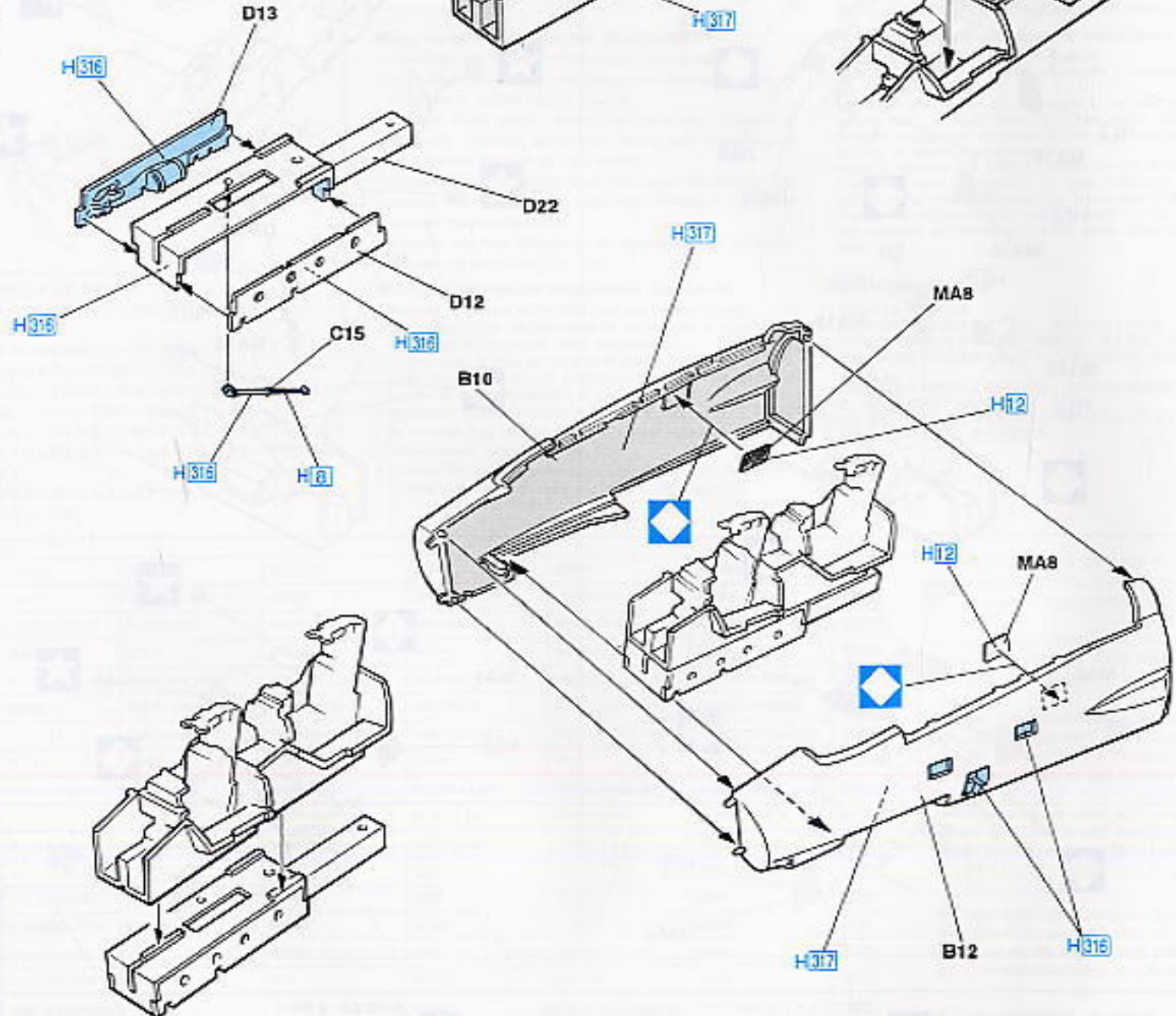

5

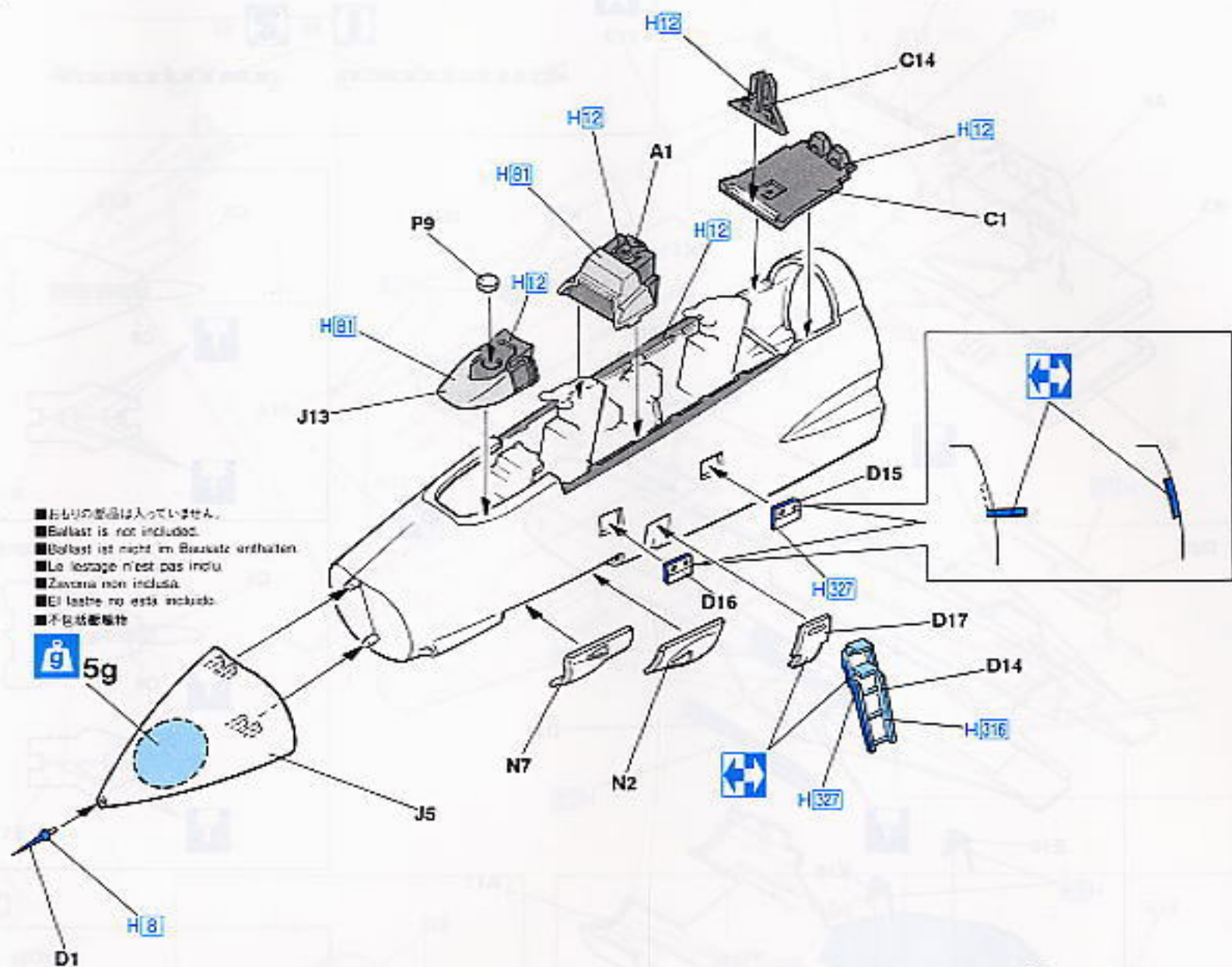

6

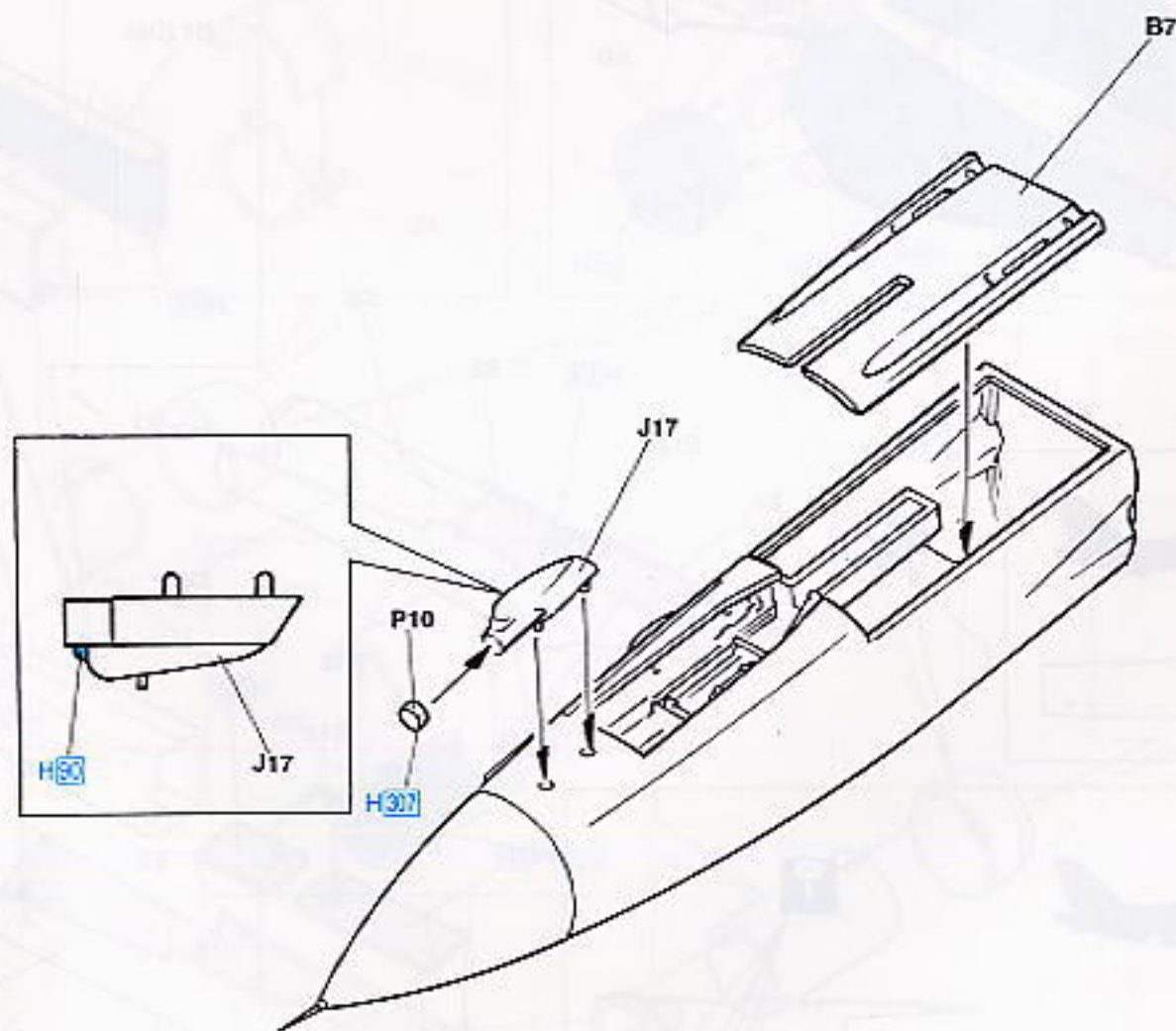

7

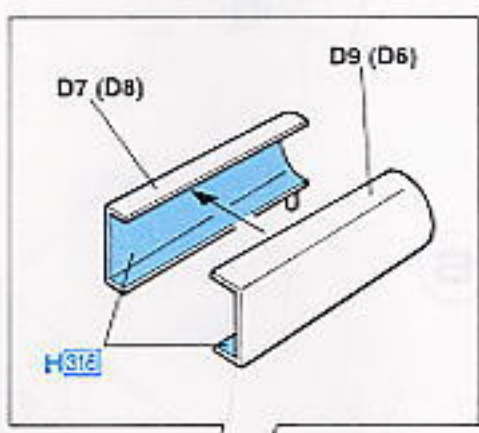
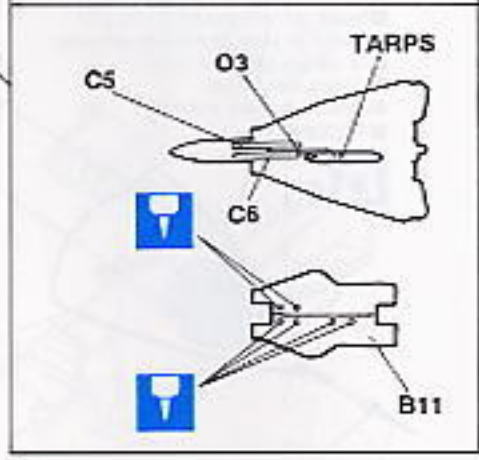
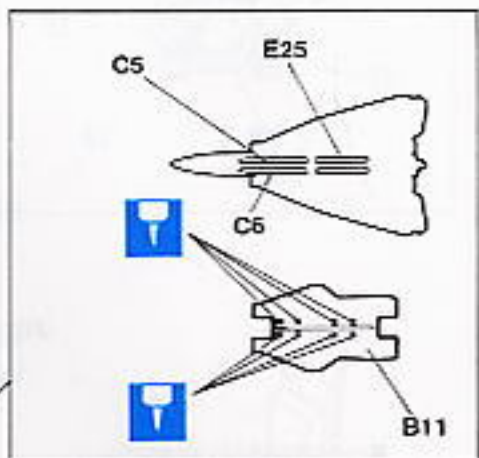
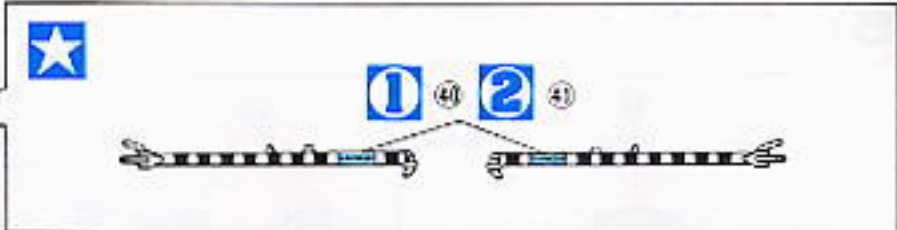
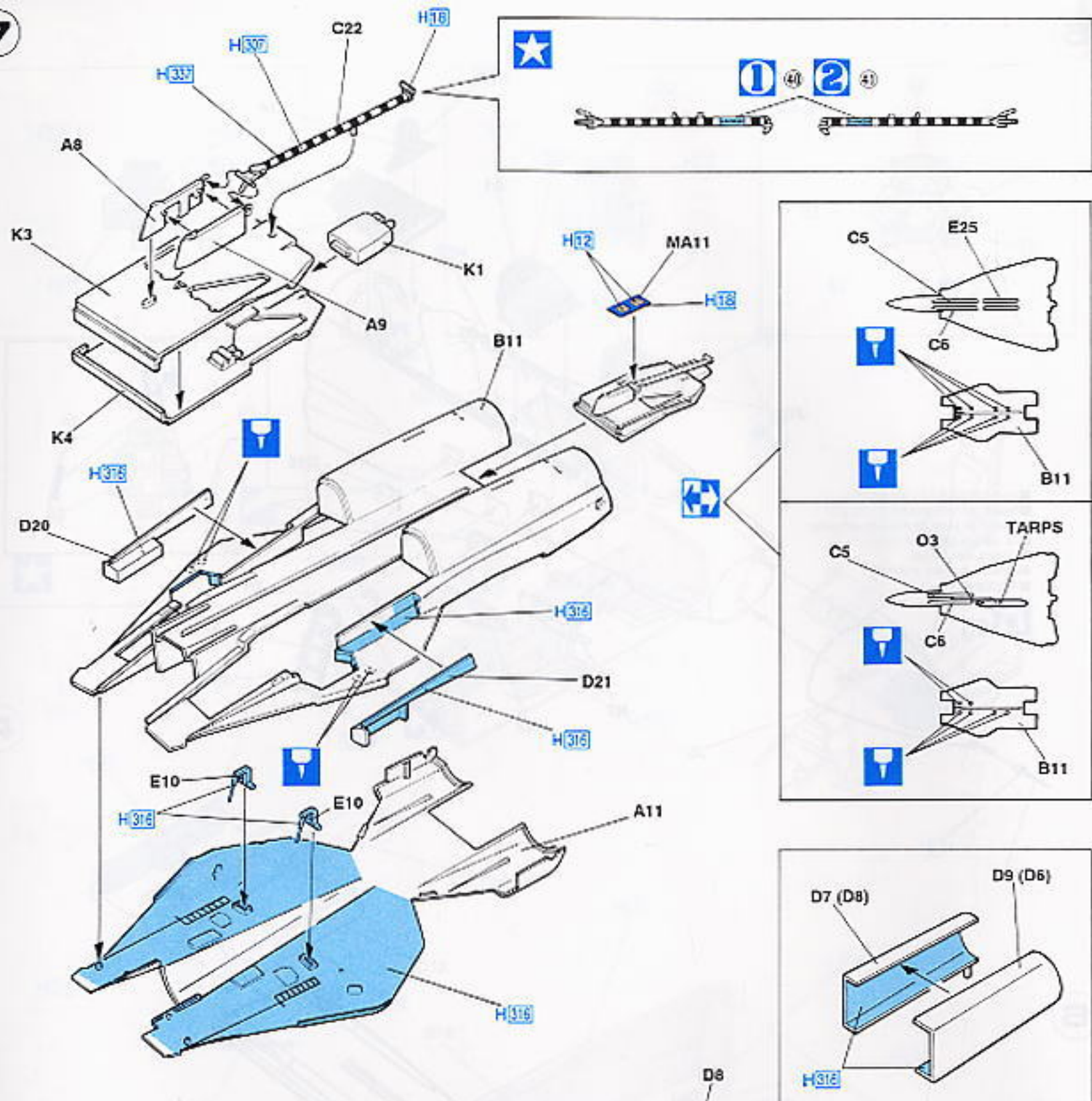

8

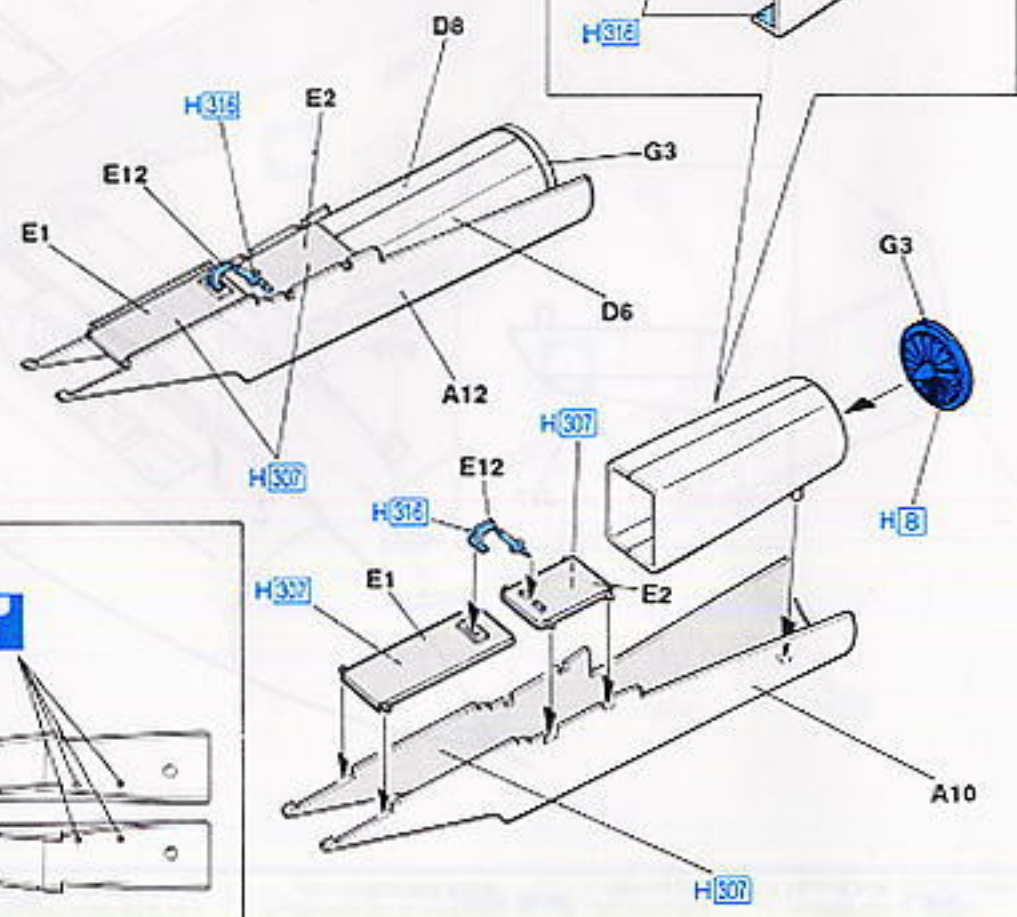
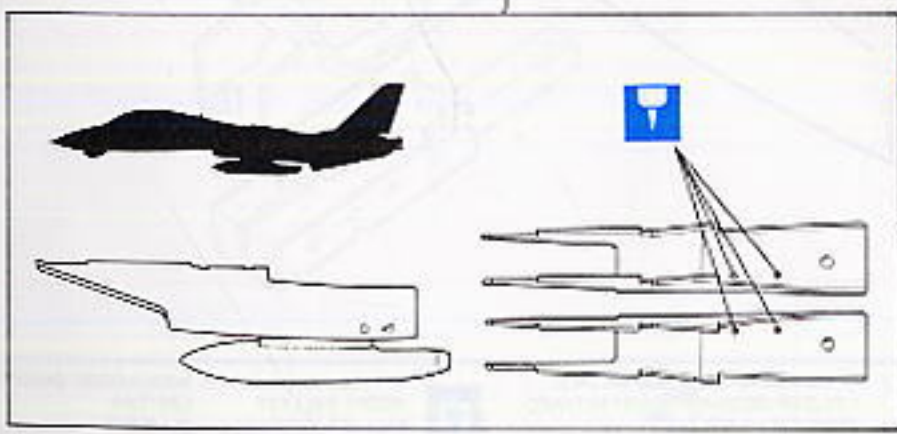
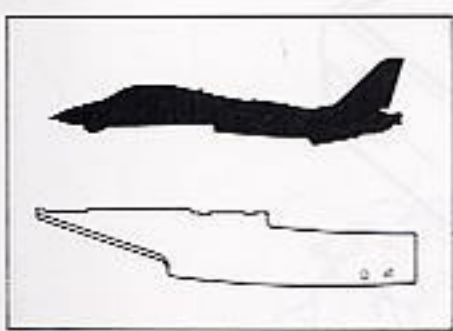

9

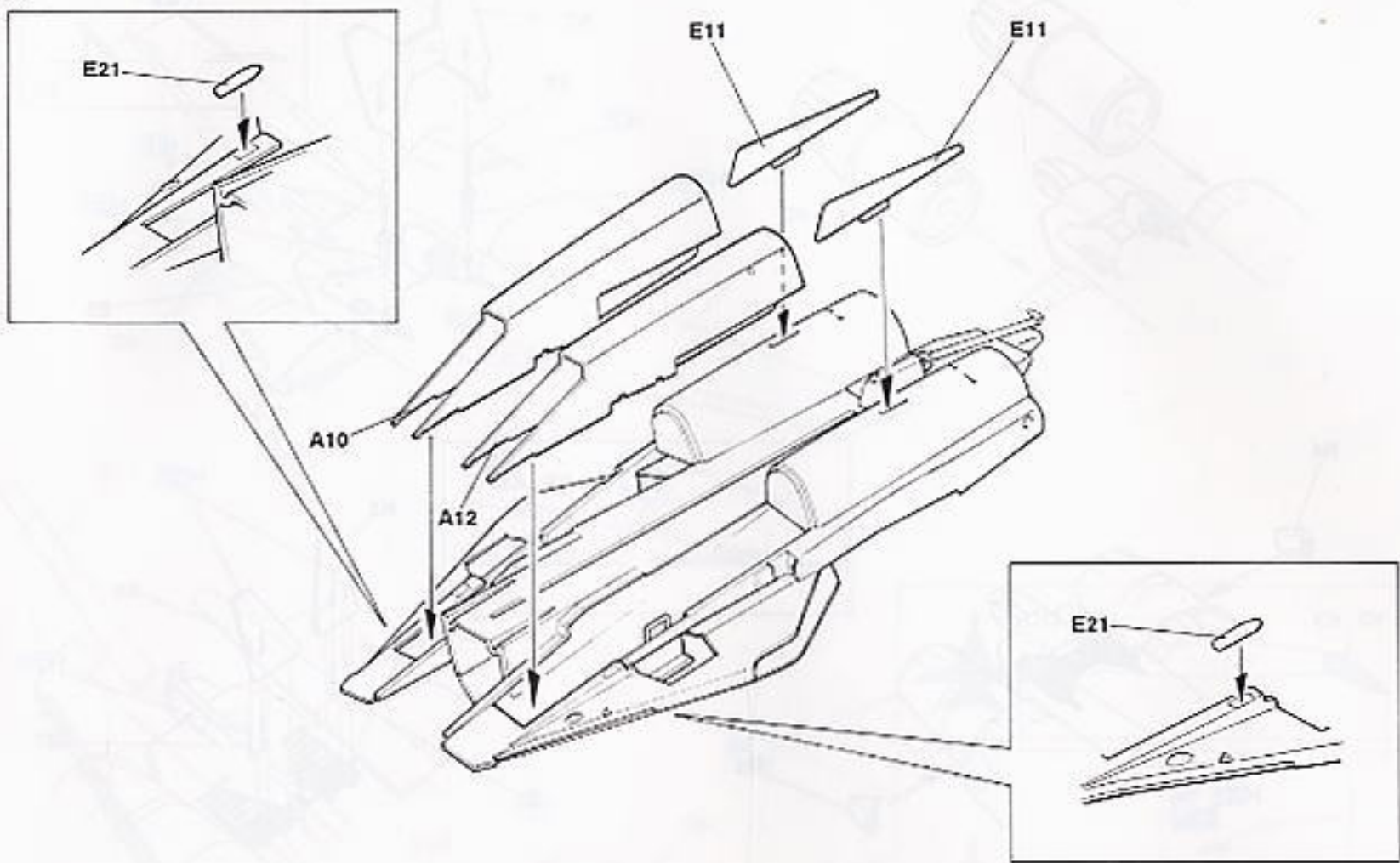

10

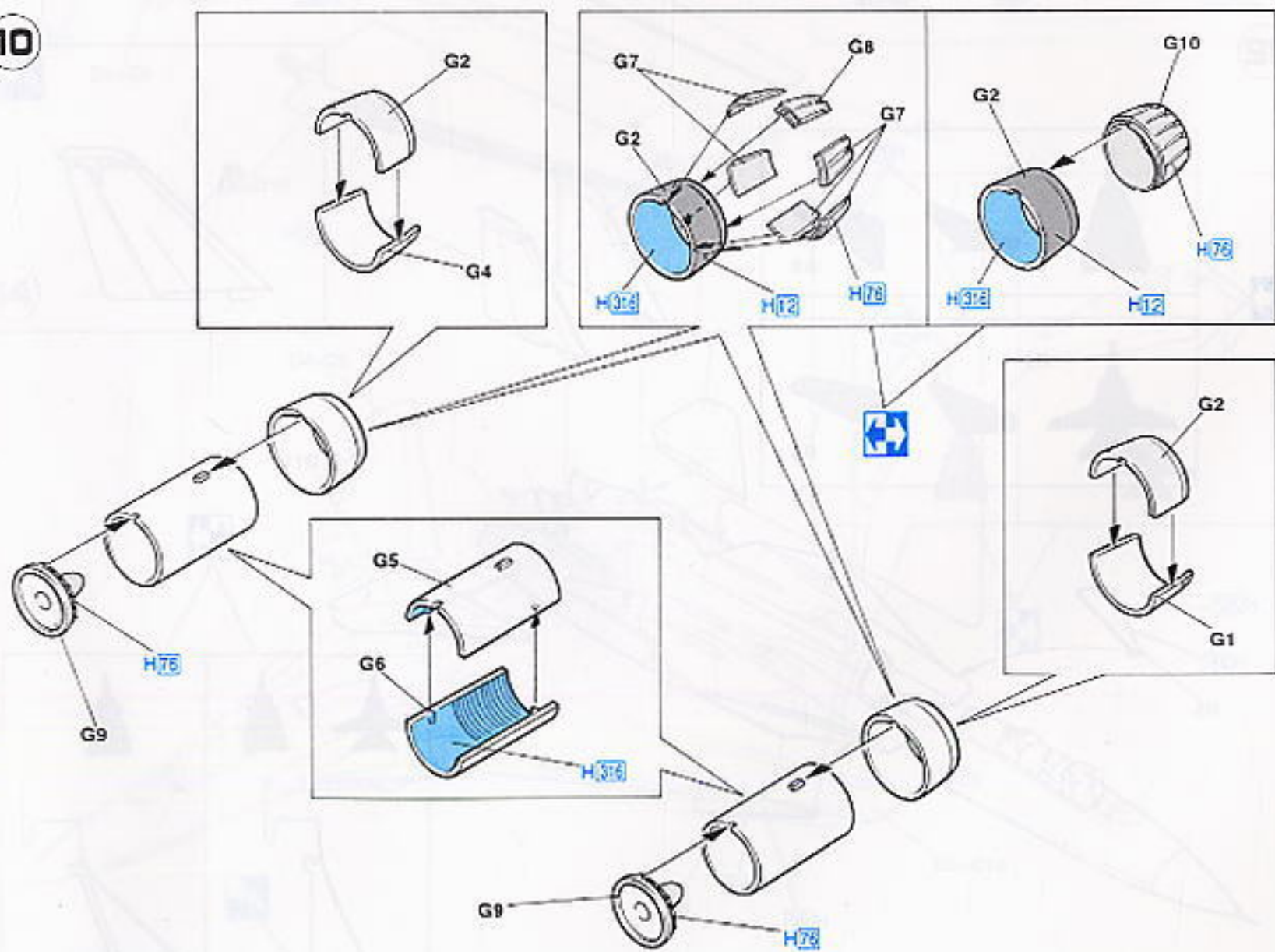

13

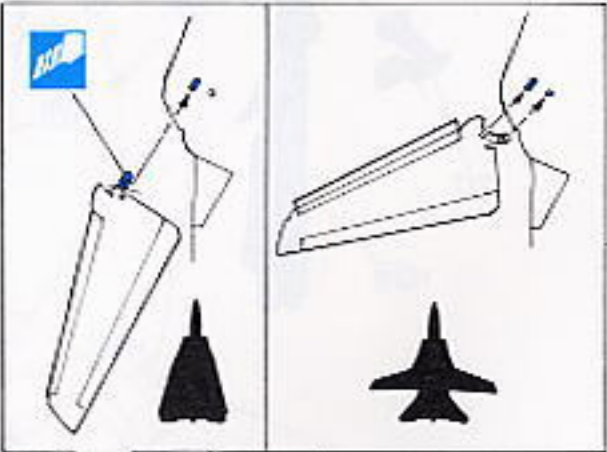
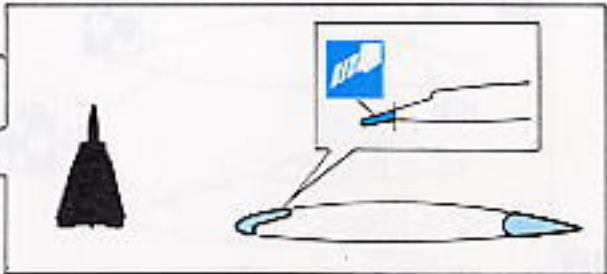
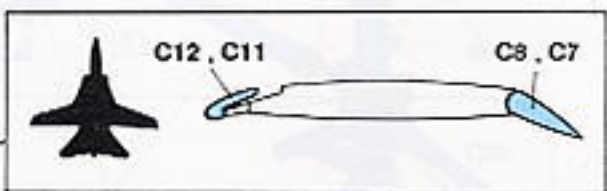
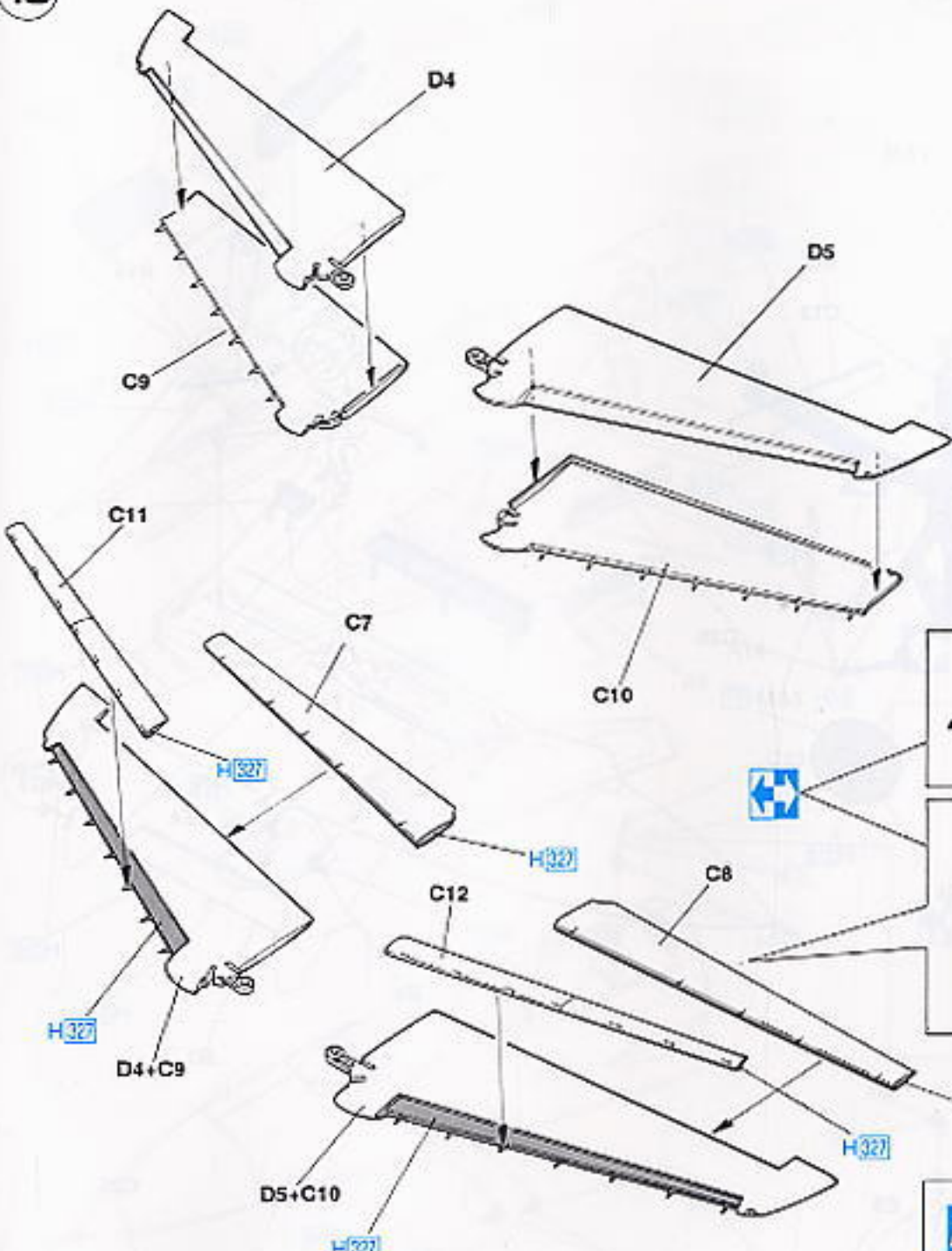

14

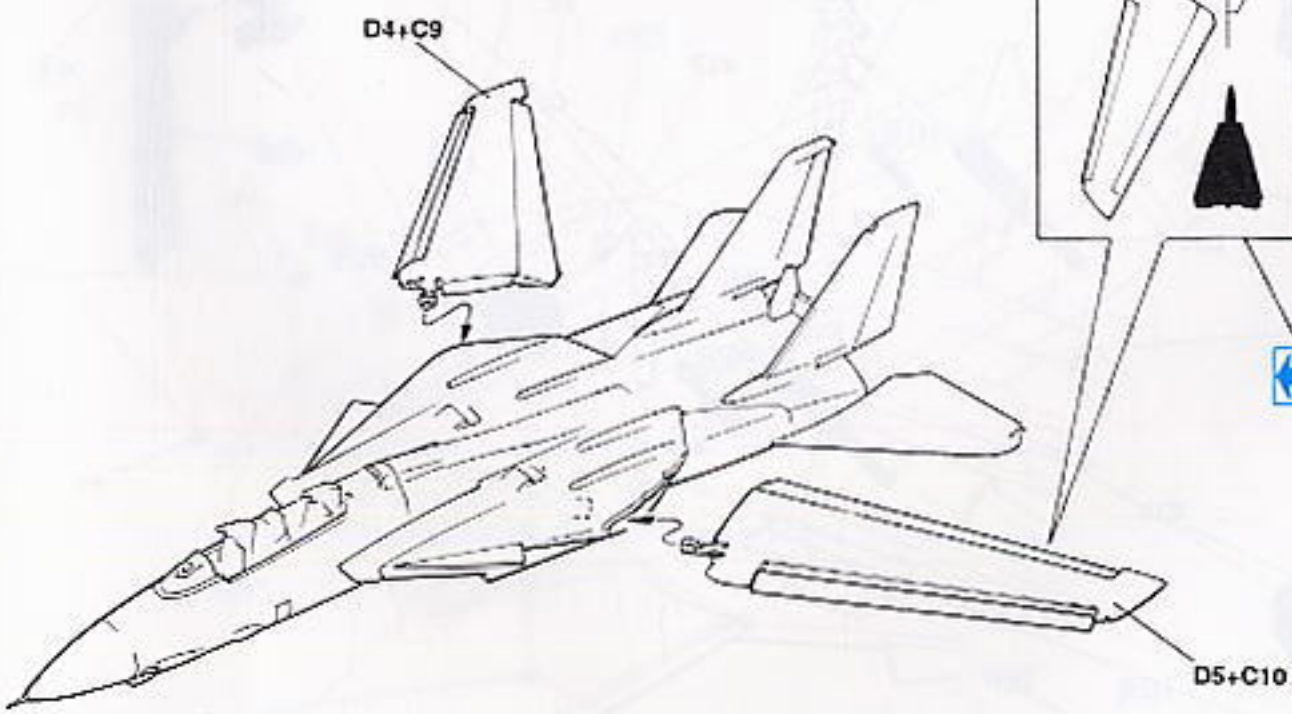

15

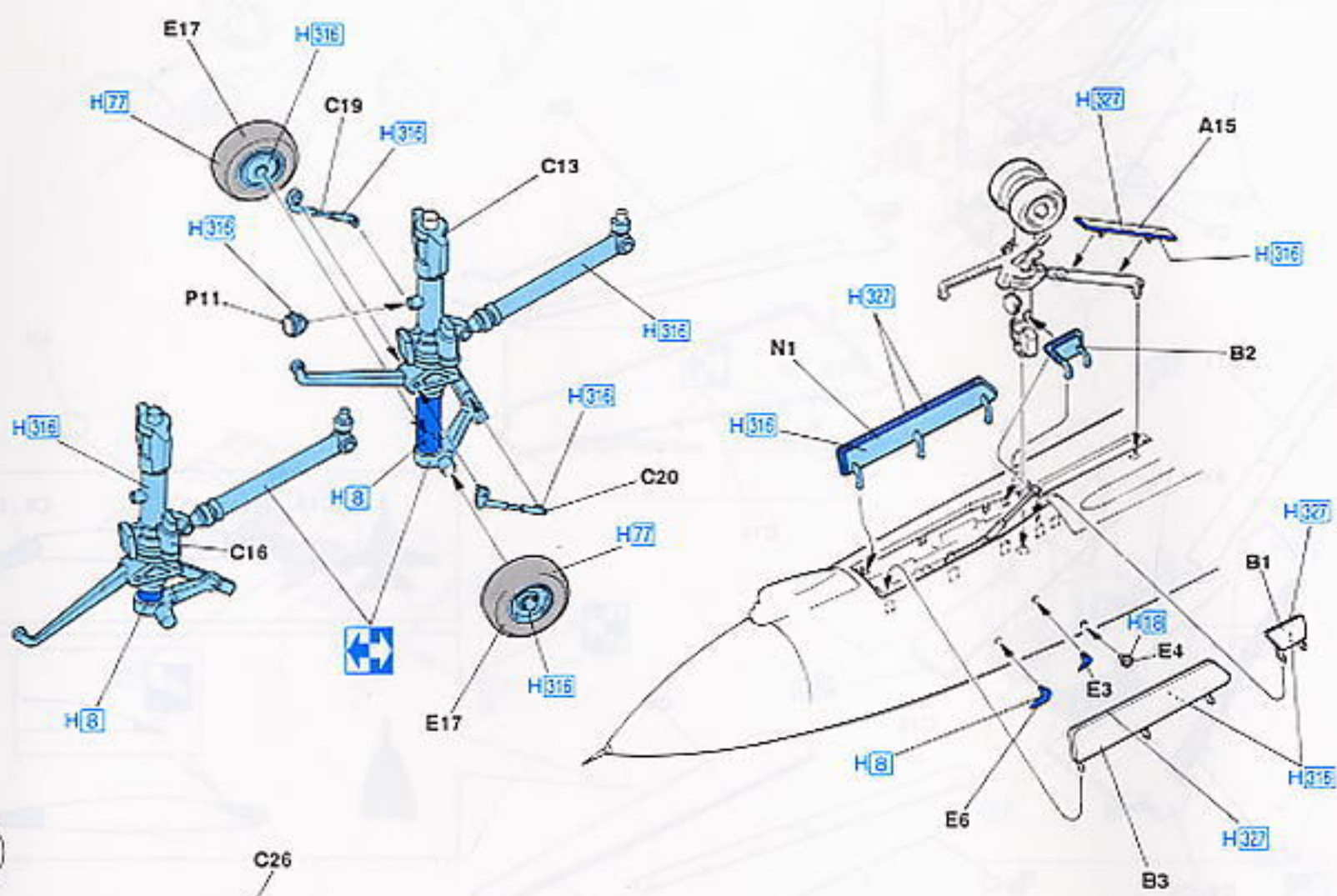

16

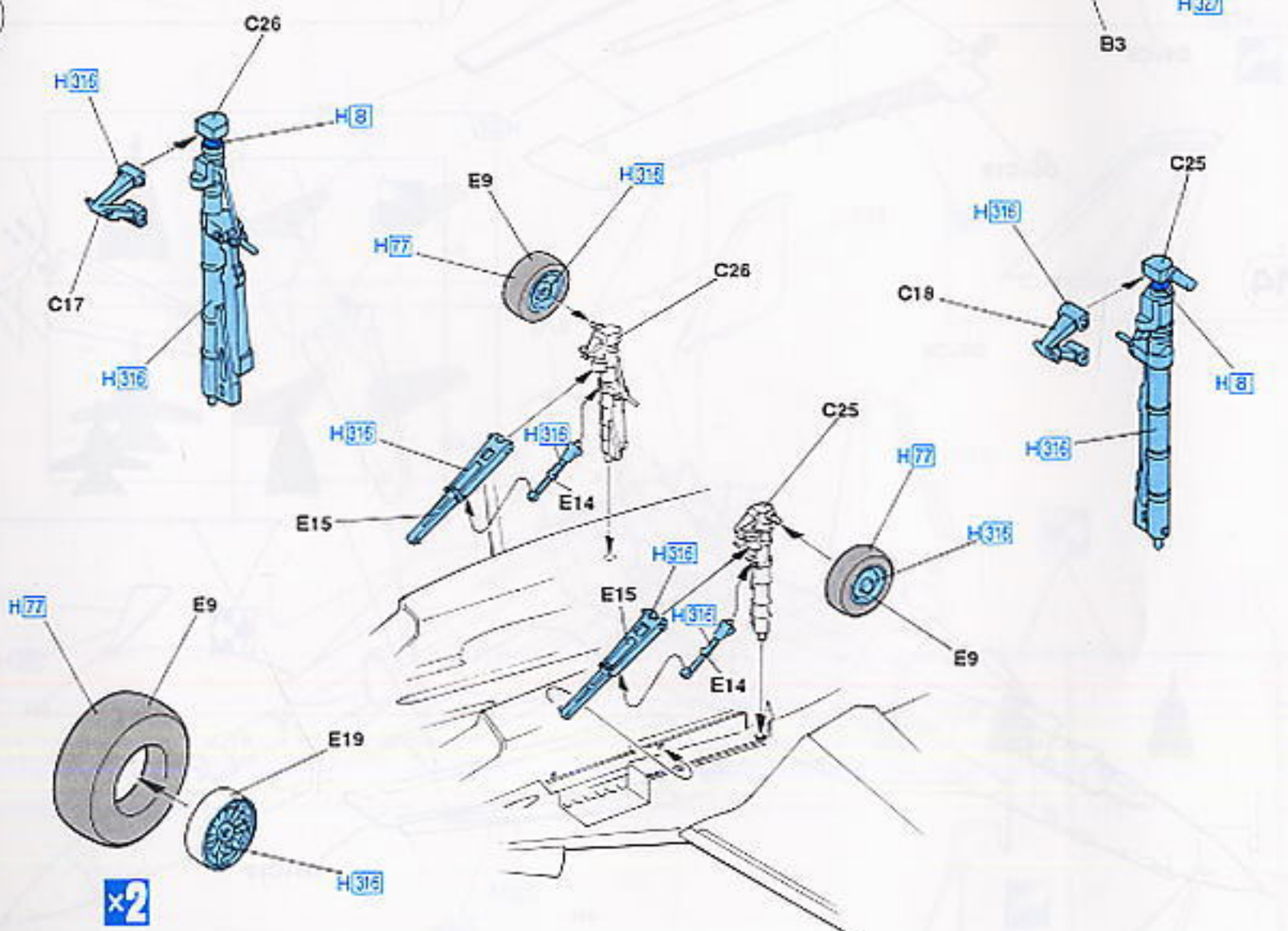

17

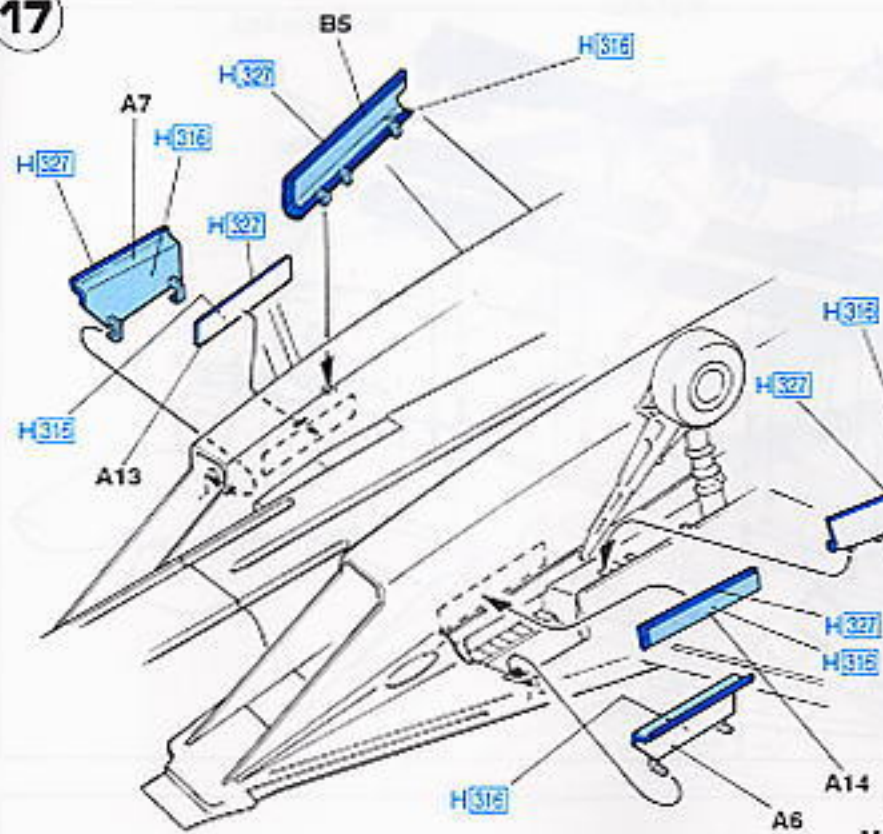

18

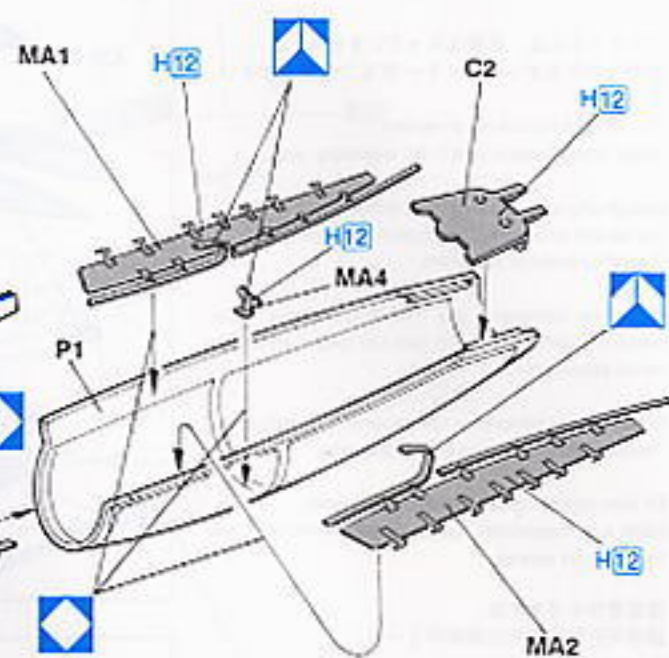

19

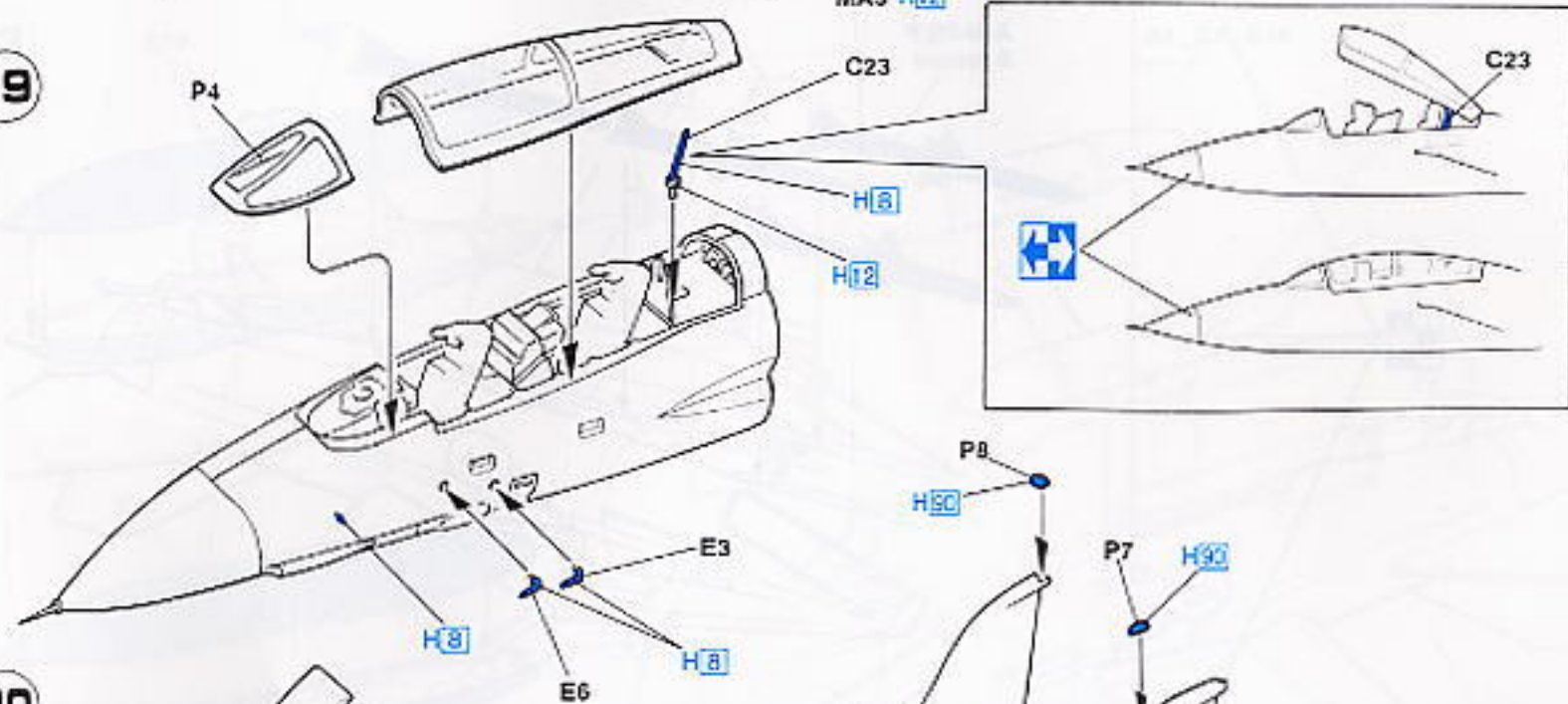

20

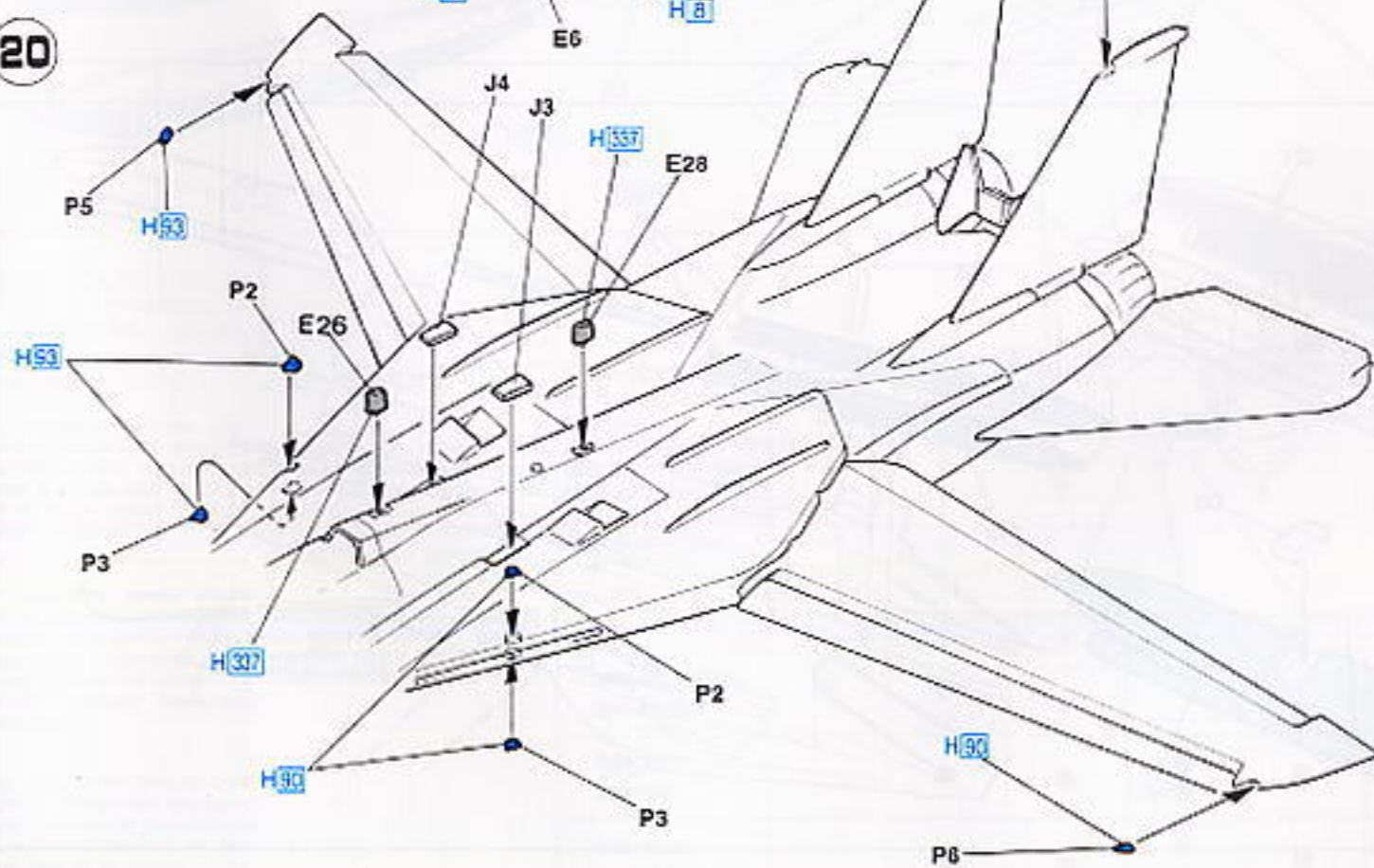

このキットには、武装は入っていません。
別売りのウエポンセット I ~ IV をご使用ください。

This kit does not include armament.
Select from "Weapon Sets I - IV" separately sold.

Bewaffnung ist im Bausatz nicht enthalten.
Die separat erhältlichen Teile sind in "Weapon Sets I - IV"
(Bewaffnungssätze) aufgeführt.

Ce kit ne comprend pas l'armement. Faites votre
sélection à partir du "Weapon Sets I-IV" (sets d'armement)
vendu séparément.

Questo kit non comprende l'armamento. Scegliere tra i
"Weapon Sets I - IV" venduti separatamente.

En este modelo no se incluye el armamento.
Están a su disposición Juegos de armamento I-IV que
se venden por separado.

這套零件中沒有武裝。
請使用另外出售的武裝組件 I ~ IV。

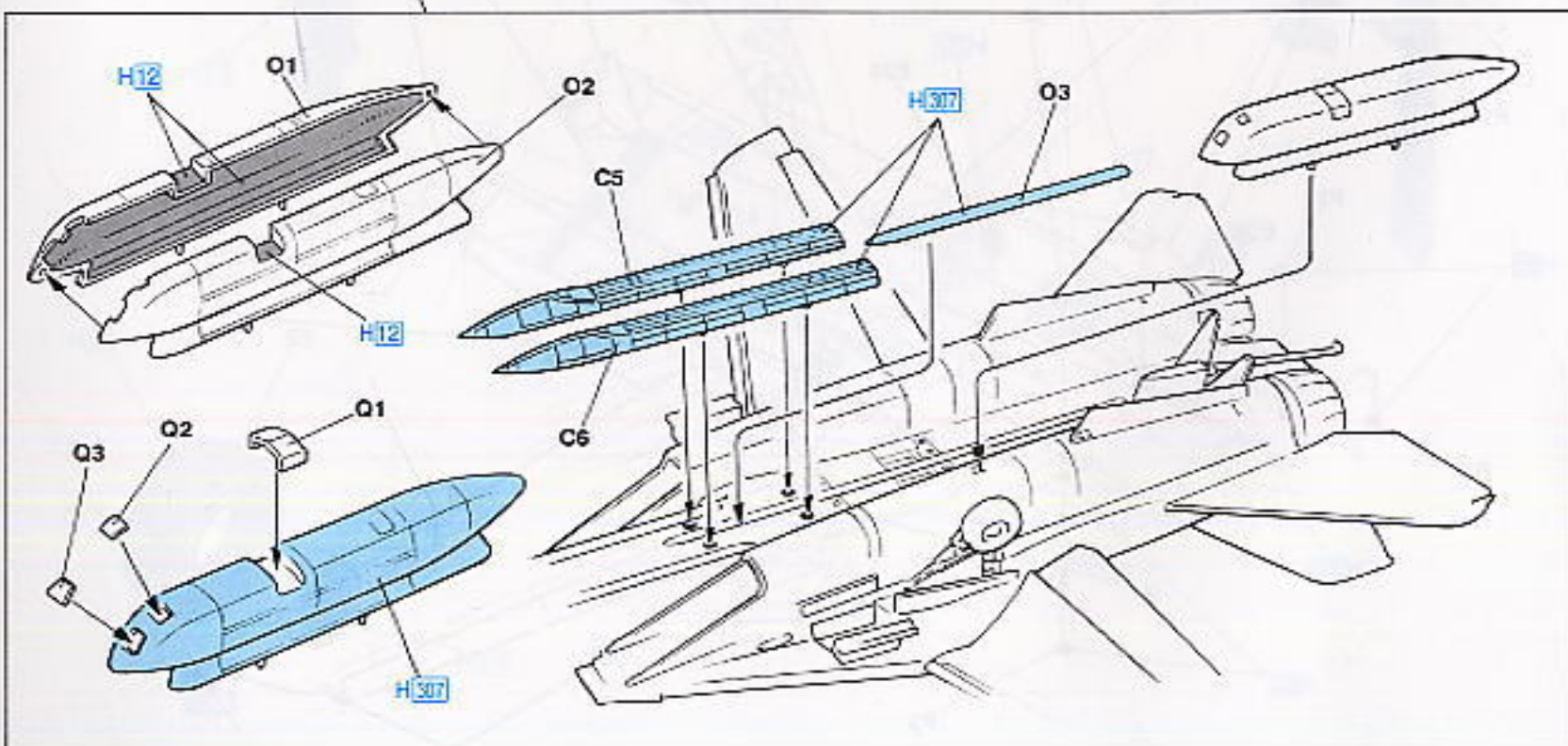
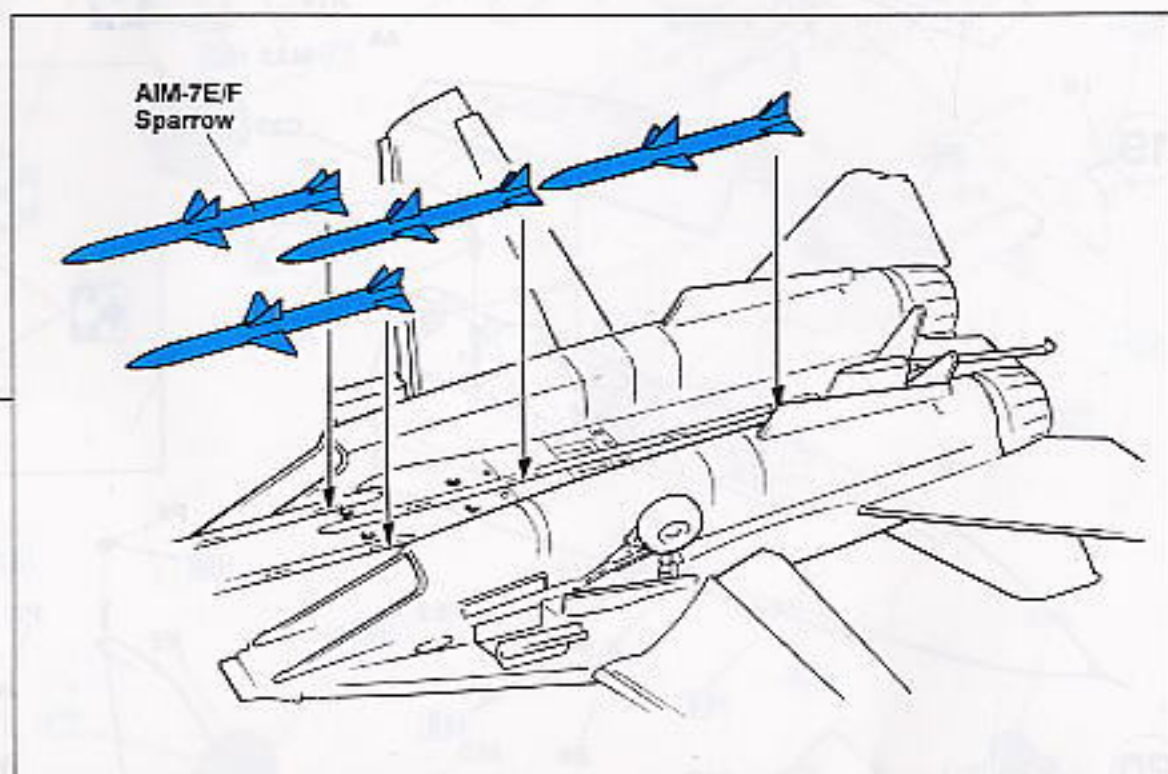
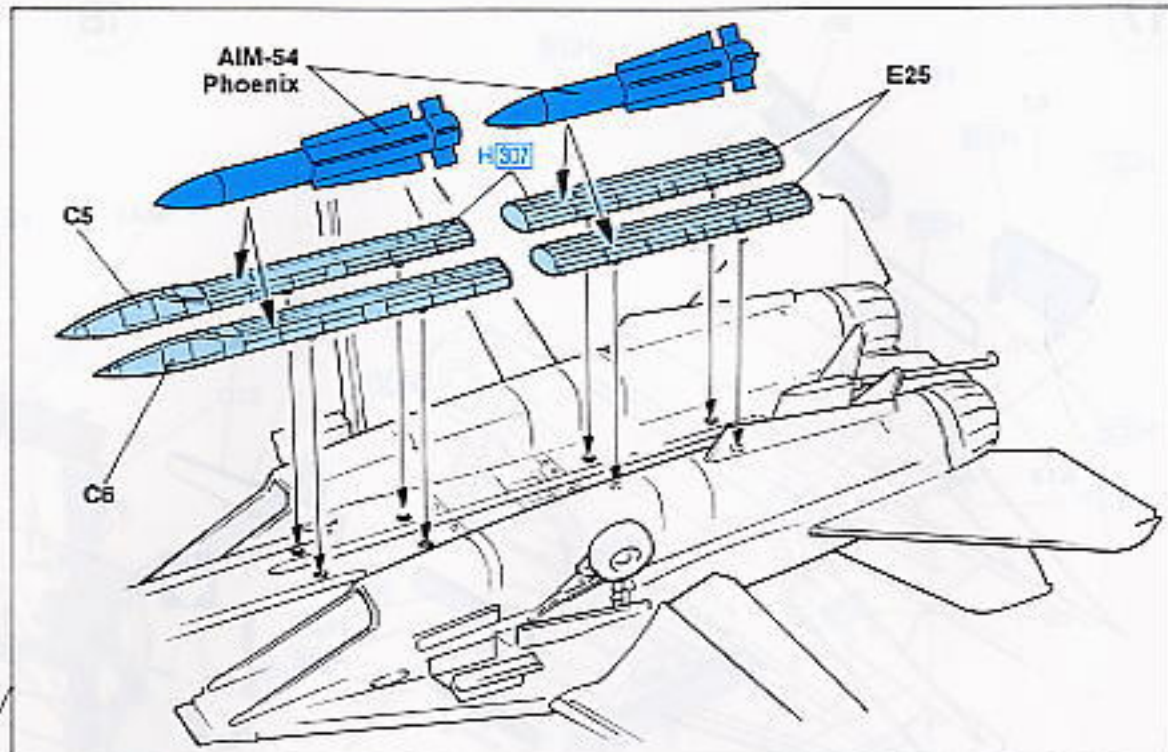

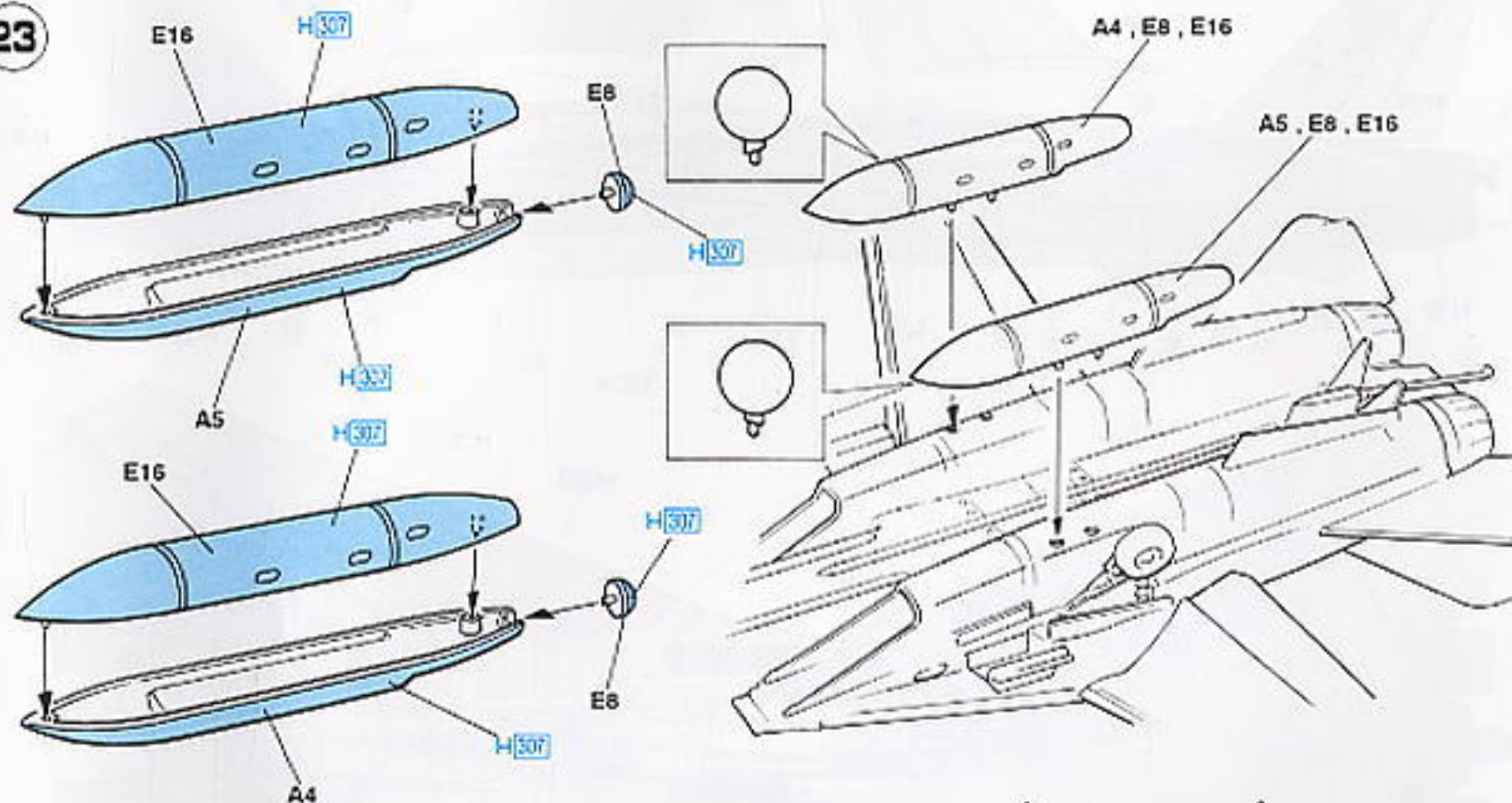
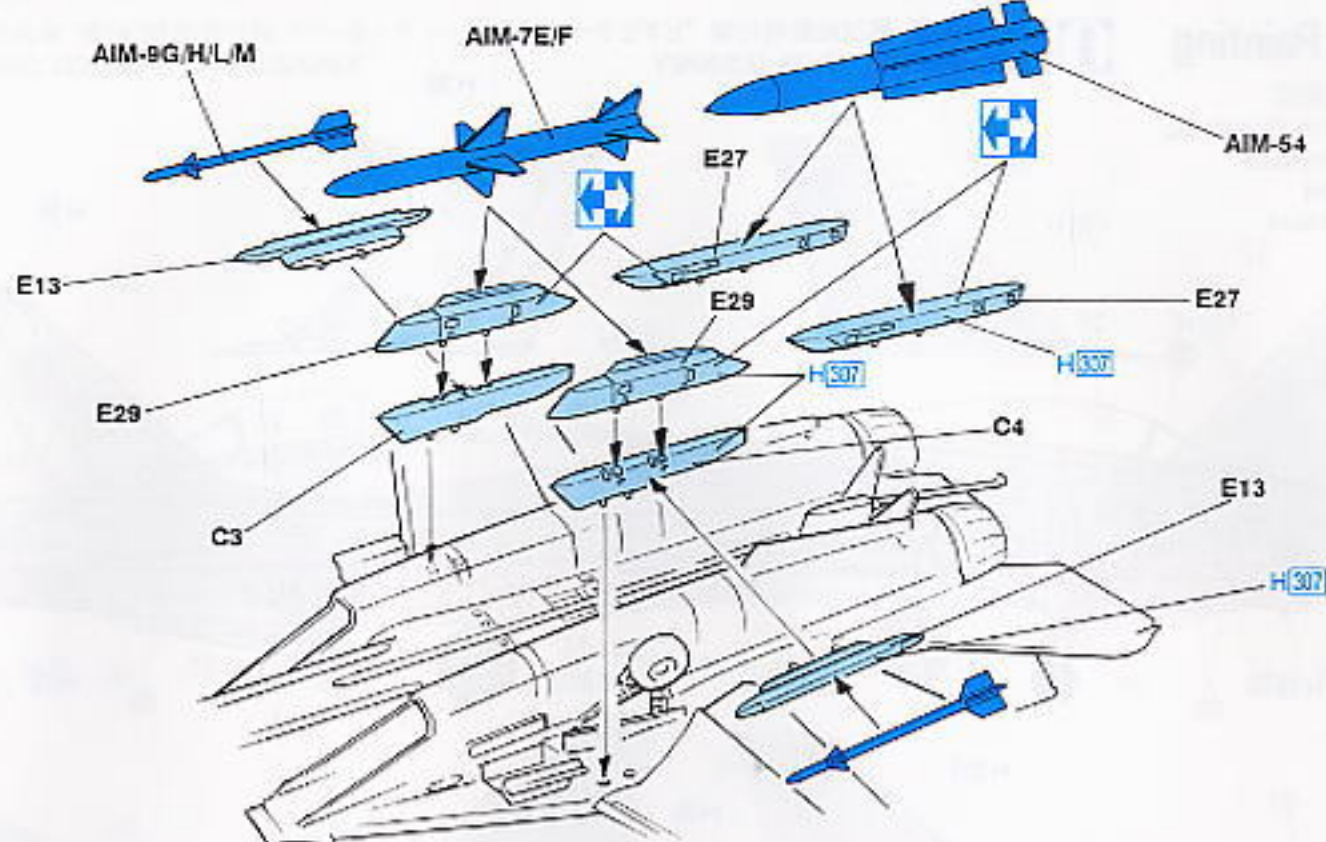

1:72スケール エアクラフト イン
アクション シリーズの豊富なウェ
ポンや各種支援車両、人形を使っ
て武装のパリエーションやディオ
ラマをお楽しみください。

Si suggerisce di combinare
questo modello con armamento
abbondante con veicoli e figure
disponibili da 1:72 Aircraft in
Action Series per costruire
diorama realistici.

It is suggested that you com-
bine this model with abundant
weapons, support vehicles and
figures available from 1:72 Air-
craft in Action Series to make
realistic dioramas.

Se recomienda que combine este
modelo con abundantes armas,
vehículos de apoyo y figuras ad-
quisibles desde la escala 1:72
en aviones de acción para
realizar dioramas realísticos.

Wir empfehlen, dieses Modell
mit umfassender Bewaffnung,
Service-Fahrzeugen und Figuren
auszustatten. Hasegawa bietet
dieses Zubehör mit seiner 1:72
"Aircraft in Action" Serie zum
Diorambau.

你可以把這枚模型配合1:72飛機戰鬥
系列、豐富多樣的武器裝備、地勤支援
車輛及地勤人員使用。製作富含充滿
真感覺的各種類戰地模型組合。

Nous vous conseillons de com-
pléter ce modèle par des arme-
ments, véhicules et personnages
de maintenance fournis dans
le kit "Avions en action 1:72"
pour réaliser des dioramas.

外部兵裝搭載圖
EXTERNAL STORES
AUBERE
BEWAFFNUNGSPUNKTE
MATERIEL EXTERNE
DEPOSITI ESTERNI
MATERIAL EXTERIOR
機外裝備示例

STA. No.	1	2	3	4	5	6	7
AIM-9G/H/L/M Sidewinder	●	●				●	●
AIM-7E/F Sparrow		●	●	●	●	●	
AIM-120A (AMRAAM)		●	●	●	●	●	
AIM-54 Phoenix		●	●		●	●	

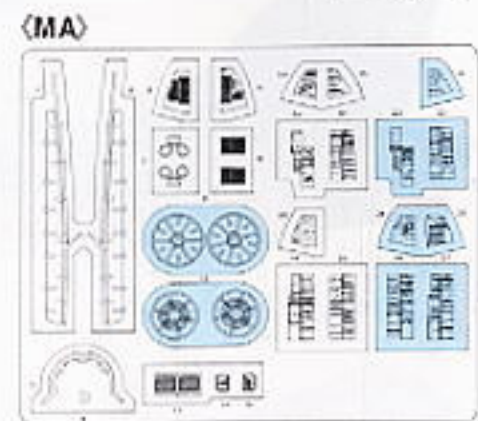
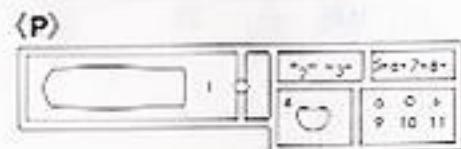
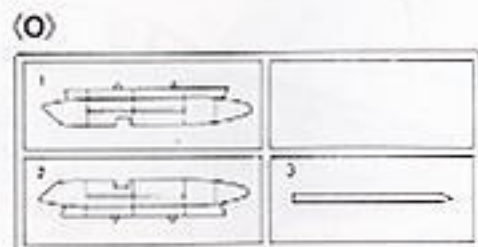
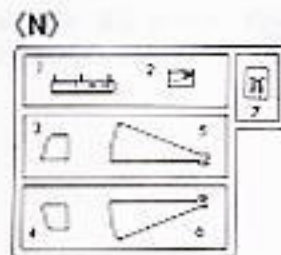
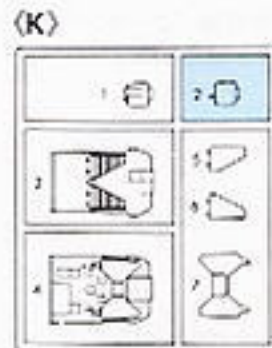
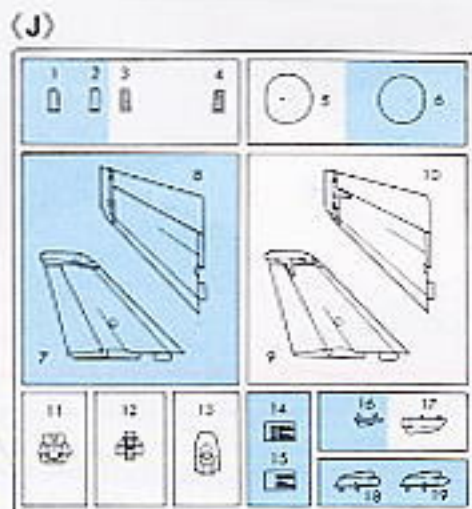
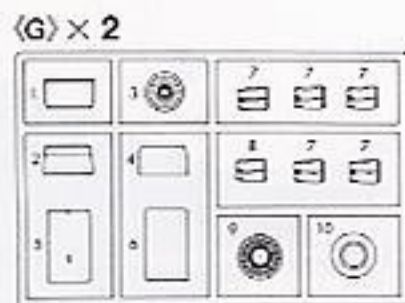
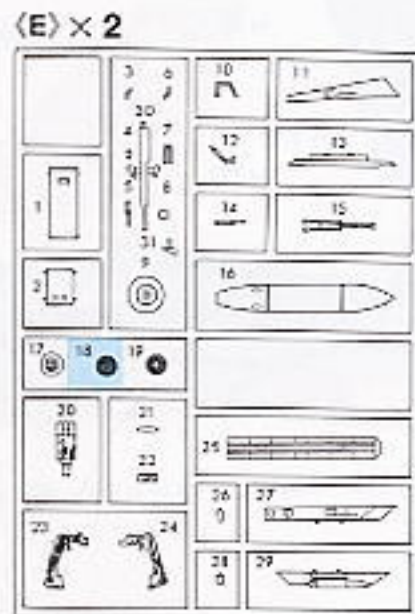
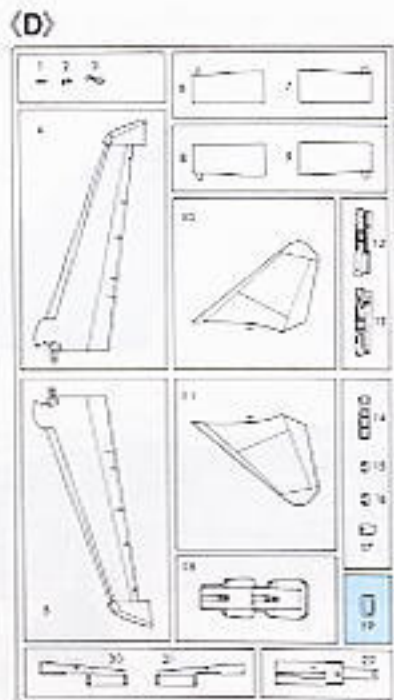
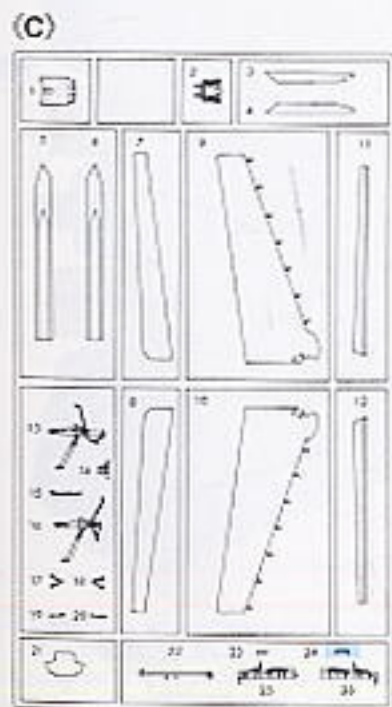
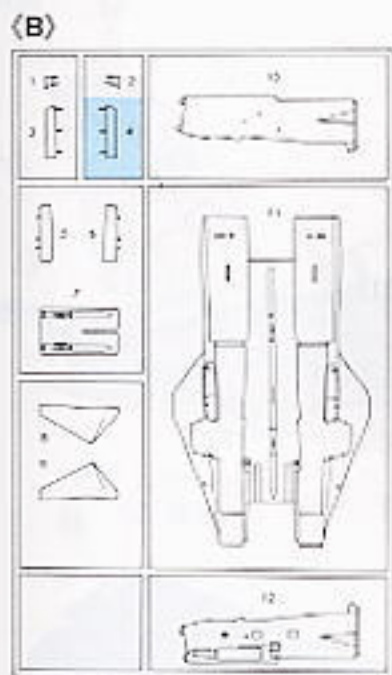
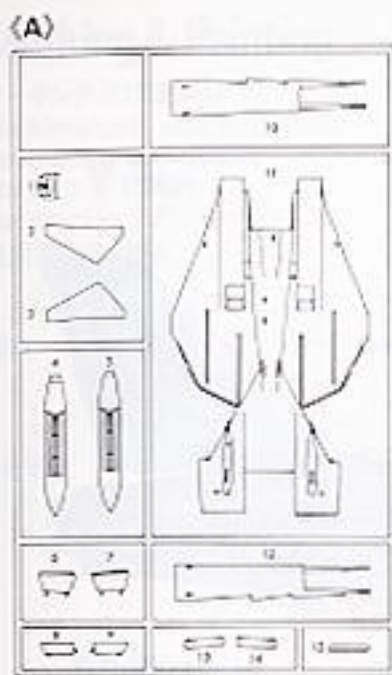

の部品は使用しません。
 Parts not for use.
 Teile werden nicht verwendet.
 Pieces à ne pas utiliser.
 Parts non per uso.
 Parties para no usar.
 不要な部品は除外

For Japanese use only.

■部品請求をなさる方は、あなたの氏名、住所、郵便番号、電話番号を1字づつはっきり書いて、下のカードと共にお申し込みください。



— 部品請求カード —

K12 1/72 F-14A プラス トムキャット

部品を紛失したり、破損なされた方は、このカードの必要部品を○でかきこみ代金を現金書留または郵便小為替で当社サービス係までお申してください。(1,000円以下の部品請求には、切手で代用もできます。)

A 部品	500円	K 部品	300円
B 部品	500円	N 部品	250円
C 部品	450円	O 部品	300円
D 部品	500円	P O 部品	250円
E 部品 (1枚)	400円	MA 部品	500円
G 部品 (1枚)	300円	マーク	300円
J 部品	400円		