

# Dassault MD312 FLAMANT

Art 72/062

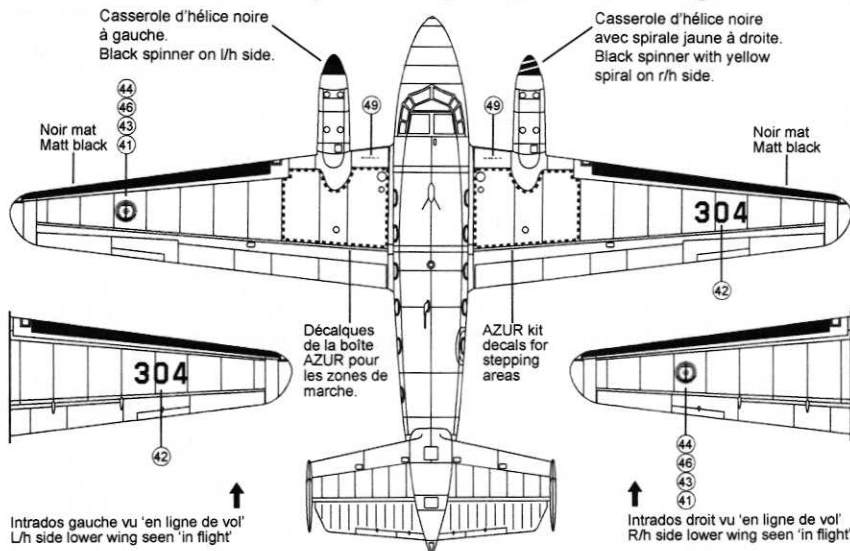

### NOTES:

Sans vouloir prétendre à une quelconque infaillibilité, nous avons réalisé toutes les décorations proposées à partir de documents photographiques. On notera sur les différents appareils représentés une grande diversité d'antennes, certains appareils changeant de configuration au gré des améliorations apportées par le constructeur. Notez que les surfaces anti-collision présentaient la plupart du temps des traces d'usure et paraissaient élavées. De même, on remarquera les marquages "à l'américaine" sur l'appareil de l'a 3S ci-contre - alors que nombre d'autres avions aient reçu les six cocardes aux positions habituelles. Le '304' est aussi l'un des rares Flamant de l'Aéronautique Navale à avoir arboré un insigne d'escadrille. Finalement, nous avons choisi de ne pas refaire les marquages des zones de marche, ceux de la maquette Azur étant de bonne qualité. Cela nous a laissé assez de place pour inclure des marquages spécifiques à quelques appareils supplémentaires.

- indique marquage des deux côtés
- indicates marking on both sides

All the decorations on this sheet have been drawn from photographic sources. Note the wide array of aerials and their different configuration on many of the aircraft, some of them swapping one aerial system for another during their career. Also of interest is the state of the dayglo surfaces, mostly worn and washed out on many aircraft (apart from the restored '319-CG' in pristine condition), making it sometimes difficult to see them on B&W photographs. Similarly, note the 'american' style wing markings for the Aéronautique Navale machine (as drawn on the left), with roundels on top left and bottom right wings and the number '304' in the other two locations - whereas many naval Flamants were seen with six roundels. '304' is also one of the few machines to sport an 'escadrille' insignia.

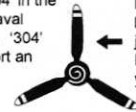

# Hawker SEA HAWK

Art 72/062

F.Mk1 - WF182/101  
898NAS  
RNAS BRAWDY - 1954

RECOMMENDED / RECOMMANDÉ  
"Sea Hawk from the cockpit" By Michael J DOUST  
(AD HOC Publications)  
"Hawker Sea Hawk" by Tony BUTLER (Warpaint N°20)

Extra Dark Sea Grey extends to lower wing and tailplane leading edges  
Le camouflage Extra Dark Sea Grey recouvre le bord d'attaque de l'intrados de la voilure et du stabilo

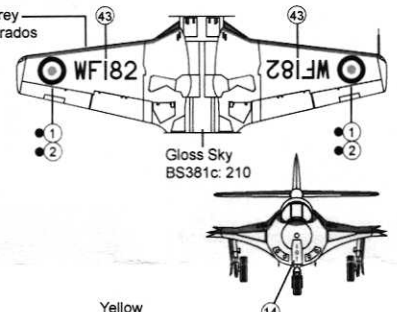
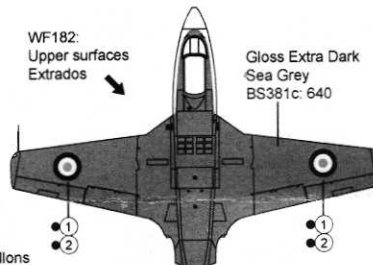

FGA.Mk6 - XE409/161/O  
802NAS  
HMS BULWARK - Suez - 1956

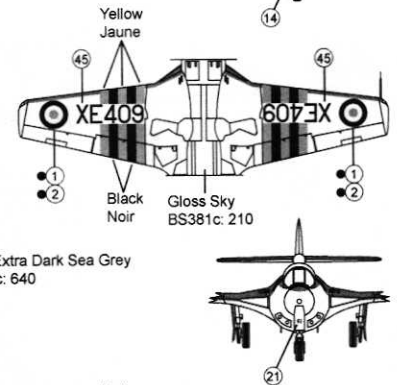
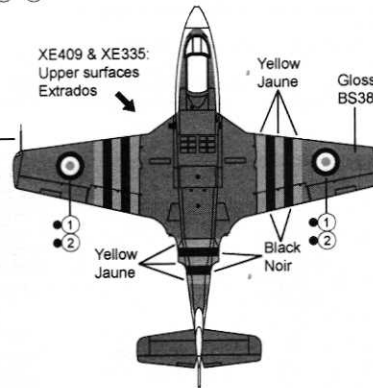
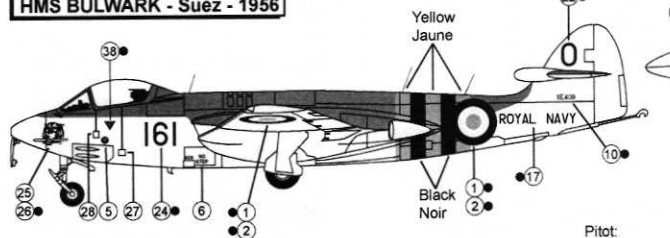

FGA.4 - XE335/234/B/Z  
810NAS  
HMS ALBION - Suez - 1956

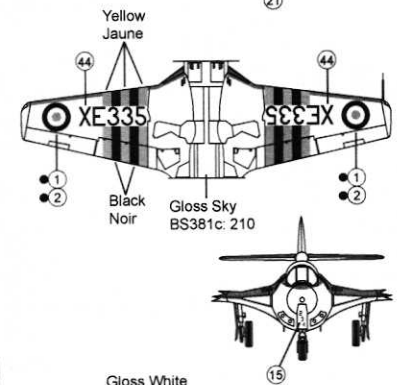
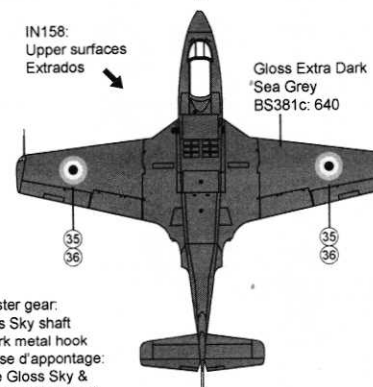
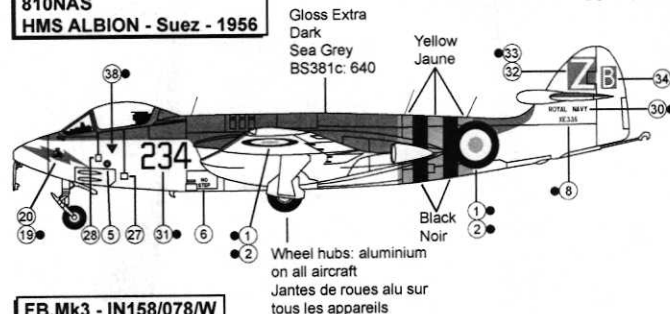

FB.Mk3 - IN158/078/W  
300 INAS  
INS VIKRANT - 1961

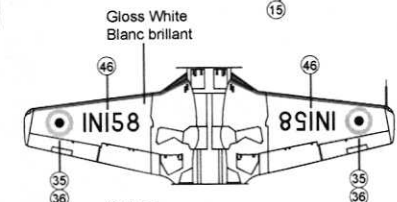
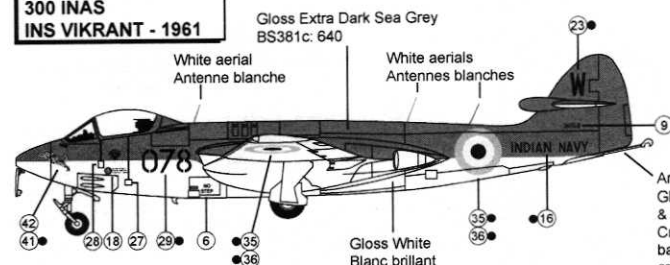

\*\*IN158:  
No number on front u/c door  
Pas de numéro sur la trappe de train avant

# Dassault MD312 FLAMANT

Art 72/062

## N°214 / 'Q' - Groupement Instruction 07/702 AVORD - 1958

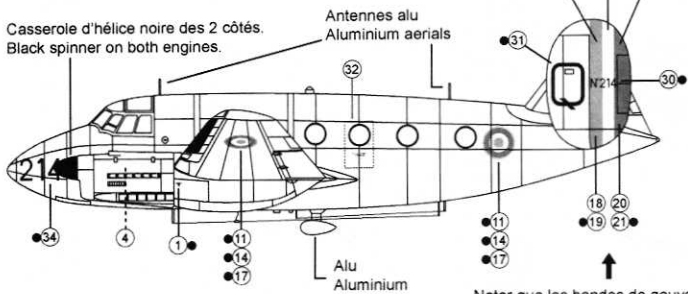

## N°205 / 'D' - Gr. Instruction 07/702 AVORD - 1959

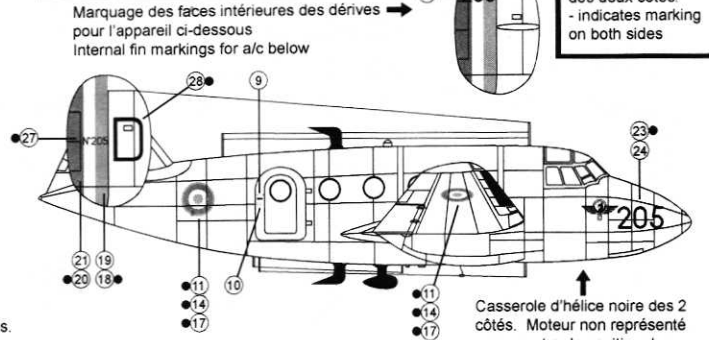

## N°217 / 118-IO - C.E.A.M. MONT-DE-MARSAN - circa 1960

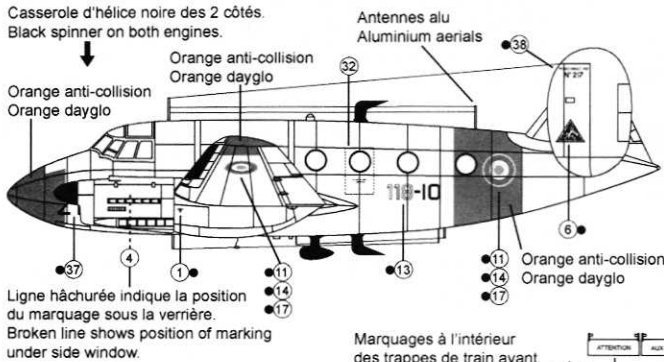

## N°304 - Escadrille de Servitude 3S CUERS-PIERREFEU - 1964

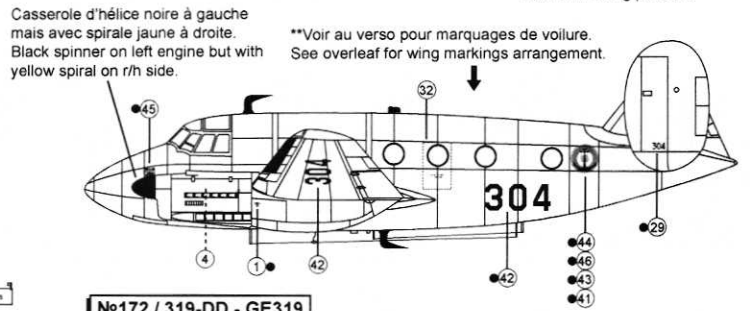

## N°200 / 13-TA - SLVSV13 COLMAR - 1971

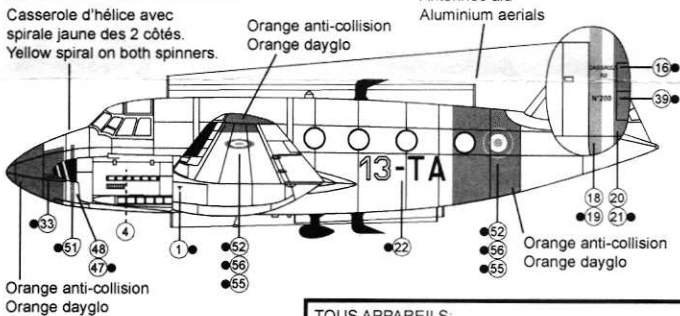

## N°172 / 319-DD - GE319 AVORD - 1979

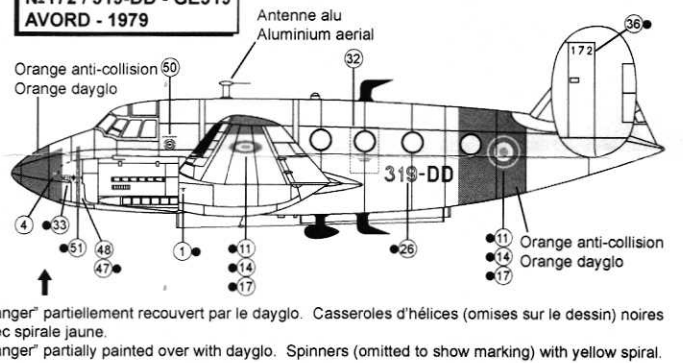

## N°153 / 319-DK - GE319 AVORD - 1979

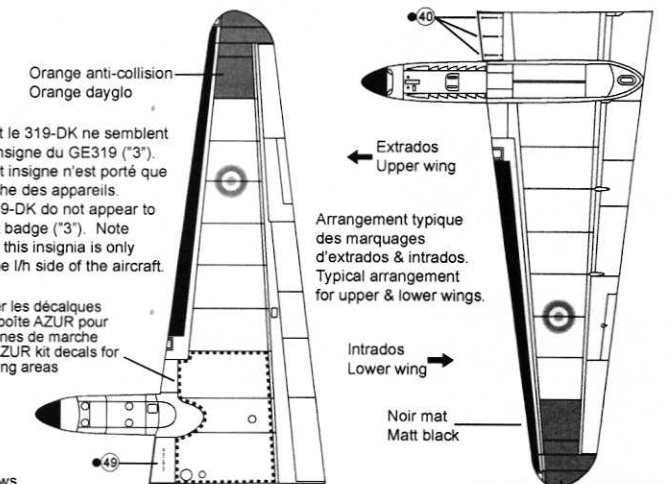
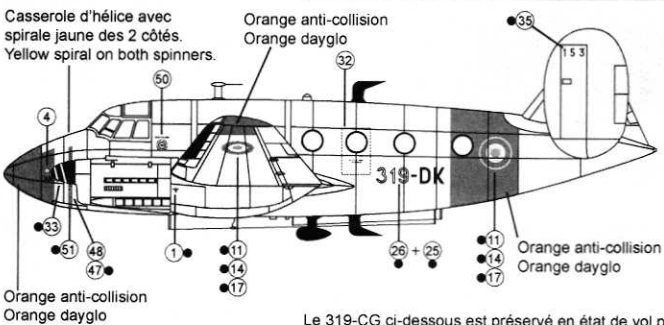

## N°226 / 319-CG / F-AZES "Montbéliard-Dassault 312" MONTBÉLIARD - 2011

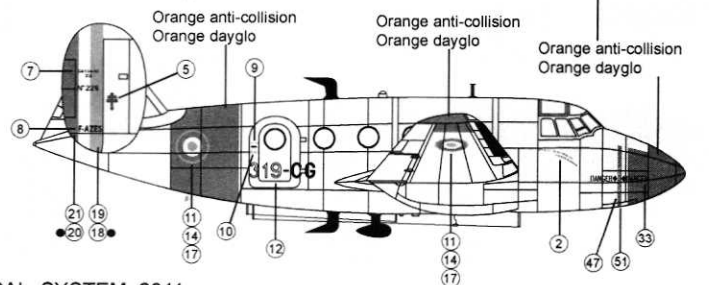
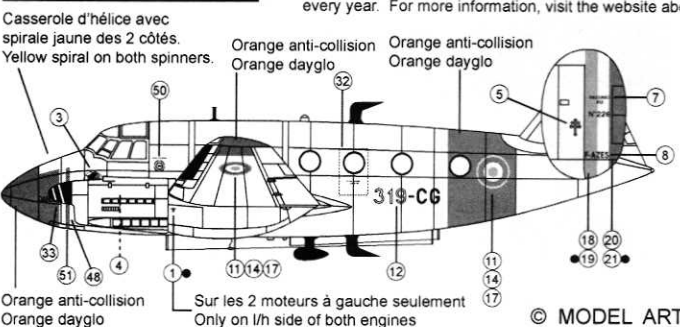

TOUS APPAREILS:  
Entièrement alu. Antennes noires sauf indication contraire.  
ALL AIRCRAFT:  
Overall aluminium. Black aeriels unless otherwise indicated.

Le 319-DD et le 319-DK ne semblent pas porter l'insigne du GE319 ("3").  
Noter que cet insigne n'est porté que du côté gauche des appareils.  
319-DD & 319-DK do not appear to carry the unit badge ("3"). Note however that this insignia is only present on the l/h side of the aircraft.

Le 319-CG ci-dessous est préservé en état de vol par l'association "Montbéliard-Dassault 312" et participe à de nombreux meetings chaque année. Voir sur [www.montbeliard-dassault312.fr](http://www.montbeliard-dassault312.fr) pour de plus amples informations.  
A/c below preserved in flying condition and taking part in many shows every year. For more information, visit the website above.