

**ITALAEREI**MADE  
IN  
ITALY**1:35 SCALE KIT N. 219**

# BRITISH «CRUISER» TANK

## CRUSADER III

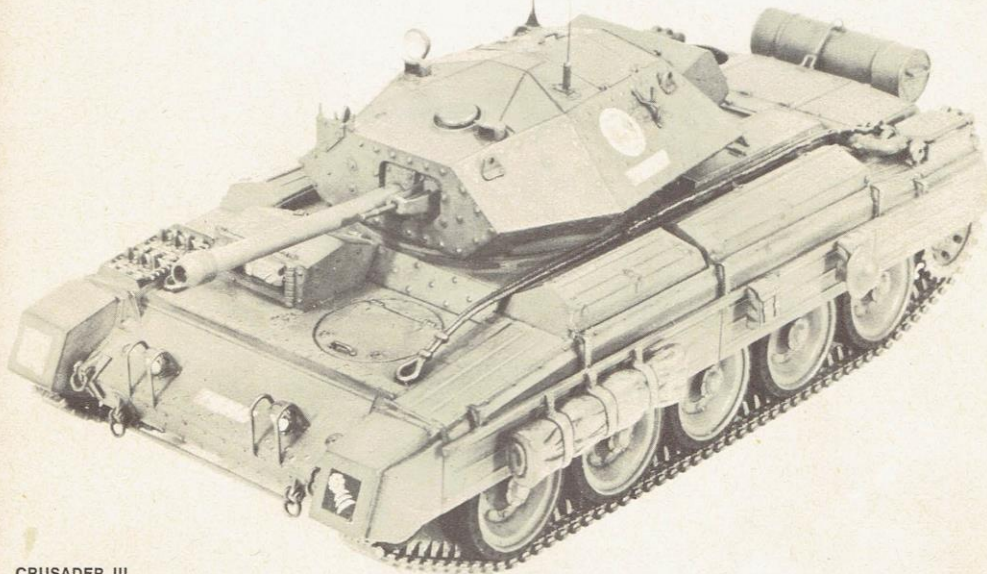

### CRUSADER III

Prodotto da un complesso di nove ditte inglesi per un totale di 5.300 esemplari, dal marzo 1940 al 1943, il carro Cruiser Mk IV subì numerose modifiche fino alla versione definitiva denominata Crusader III. Quest'ultima montava in torretta un cannone da 6 libbre (57 mm.) in sostituzione del cannone da 2 libbre (40 mm.) che aveva armato le versioni precedenti. Un'altra modifica notevole era l'eliminazione della mitragliatrice Besa dalla sovrastruttura anteriore dello scafo. Ne risultava migliorata la ventilazione del carro, insufficiente soprattutto per il teatro d'operazioni africano, ed aumentato lo spazio per il munizionamento. Infine era aumentato lo spessore della corazzatura sia frontalmente che in torretta. A partire dalla primavera del '41 il Crusader fu il più importante carro armato inglese presente in Africa; nell'autunno del '42 partecipò alla battaglia di El Alamein a fianco dei carri Sherman di produzione americana. Nel confronto con i mezzi dell'Asse, se poteva combattere alla pari contro i corazzati italiani, d'altra parte non era paragonabile al PzKpfw III: la sua corazzatura massima di 50 mm. era facilmente perforata sia dal pezzo da 50 mm. in dotazione a quel carro tedesco, che dal cannone controcarro italiano da fanteria da 47/32. Le sue doti migliori erano la velocità e la robustezza del ruotismo e delle sospensioni tipo Christie che sul difficilissimo terreno di battaglia del Nord Africa gli permisero di compensare la deficienza di armamento e protezione. Infine nei primi mesi del '43 il Crusader fu ritirato definitivamente dalla zona d'operazioni. Lo scafo rimase ancora in produzione per la realizzazione di una vasta gamma di veicoli corazzati speciali, progettati per l'invasione dell'Europa, di cui il più famoso fu il trattore d'artiglieria usato largamente sul fronte occidentale da unità divisionali controcarro armate con il pezzo da 17 libbre (76/55 mm.).

**Caratteristiche tecniche:** Equipaggio 3 uomini - Peso 22,5 t. - Lunghezza 5,98 m. - Larghezza 2,64 m. - Altezza 2,24 m. - Velocità su strada 44 km. circa - Autonomia su strada 180 km. - Armamento: 1 cannone da 57 mm. (6 pdr.) - 1 mitragliatrice Besa da 7,93 mm. coassiale - Motore: 1 Nuffield Liberty con raffreddamento a liquido erogante 340 HP a 1500 rpm.

### CRUSADER III

Produced up to 5,300 units by nine British firms, from March 1940 till 1943, the «Cruiser» tank Mk IV underwent several modifications up to the definitive version called Crusader III. It was armed with a 6 pdr. gun replacing the 2 pdr. gun of the previous versions; the frontal Besa machine-gun turret was deleted from the superstructure tank hull, a better ventilation and a larger room for ammunition being consequently achieved. Besides the gun turret and frontal hull armour thickness was increased. As from Spring 1941 the Crusader was the main British tank to be operational in the North African theatre; in Fall 1942 it took part to the battle of El Alamein together with American-built Sherman tanks. Capable of coping with the Italian AFVs, it could not compete with the German Panzer III, the 50 mm. gun of which, as well as the Italian infantry 47/32 antitank gun, could perforate its armour. On the other hand its strong and reliable Christie suspensions gave it fast speed even on very rough terrain, just like the North African one, this compensating for its armour and armament lack. At the beginning of 1943 the Crusader was definitively withdrawn from the fighting line, its hull however being still produced to be fitted for various British special AFVs, conceived for the invasion of Europe.

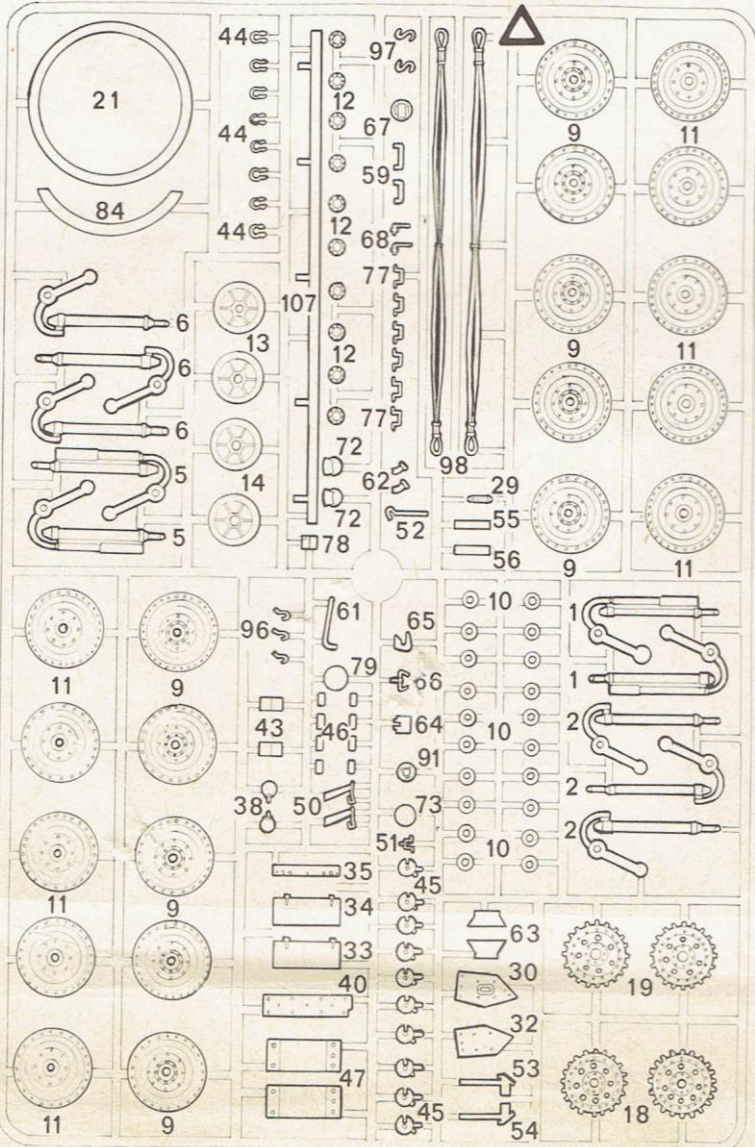
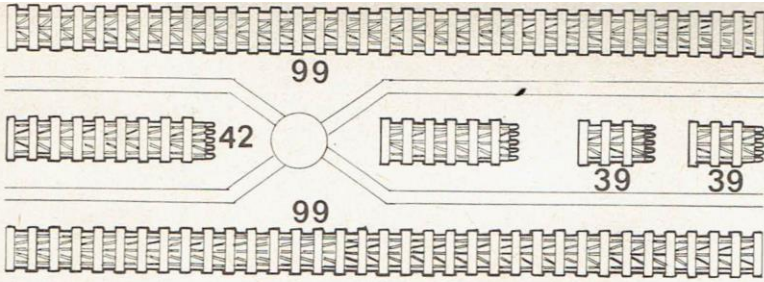

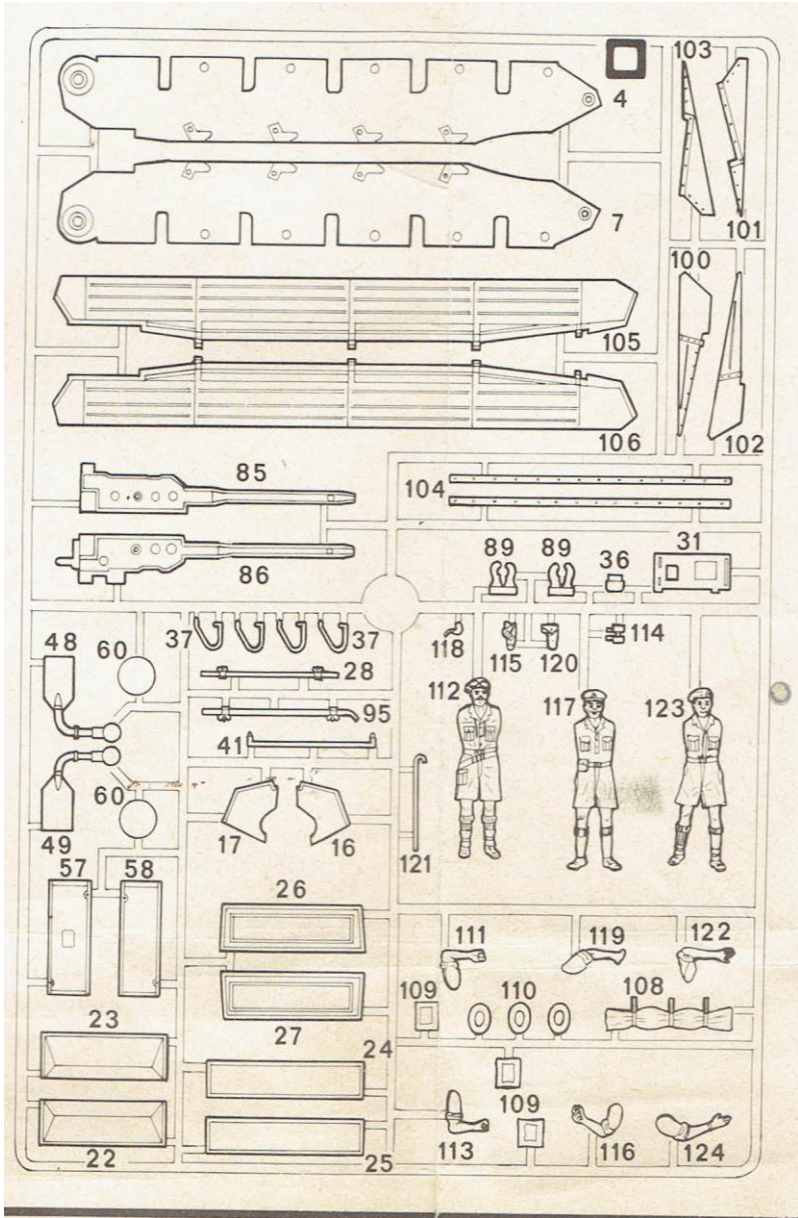

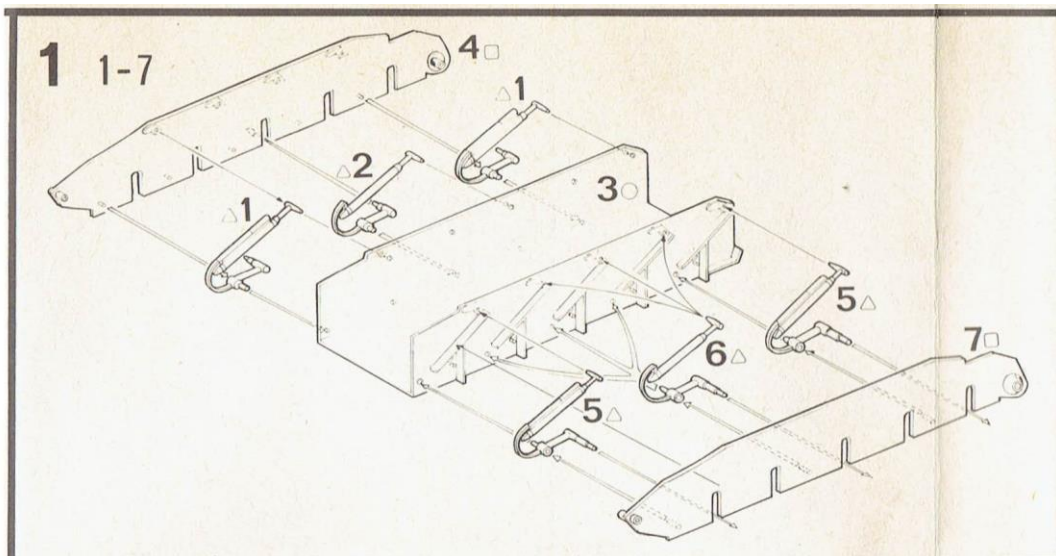
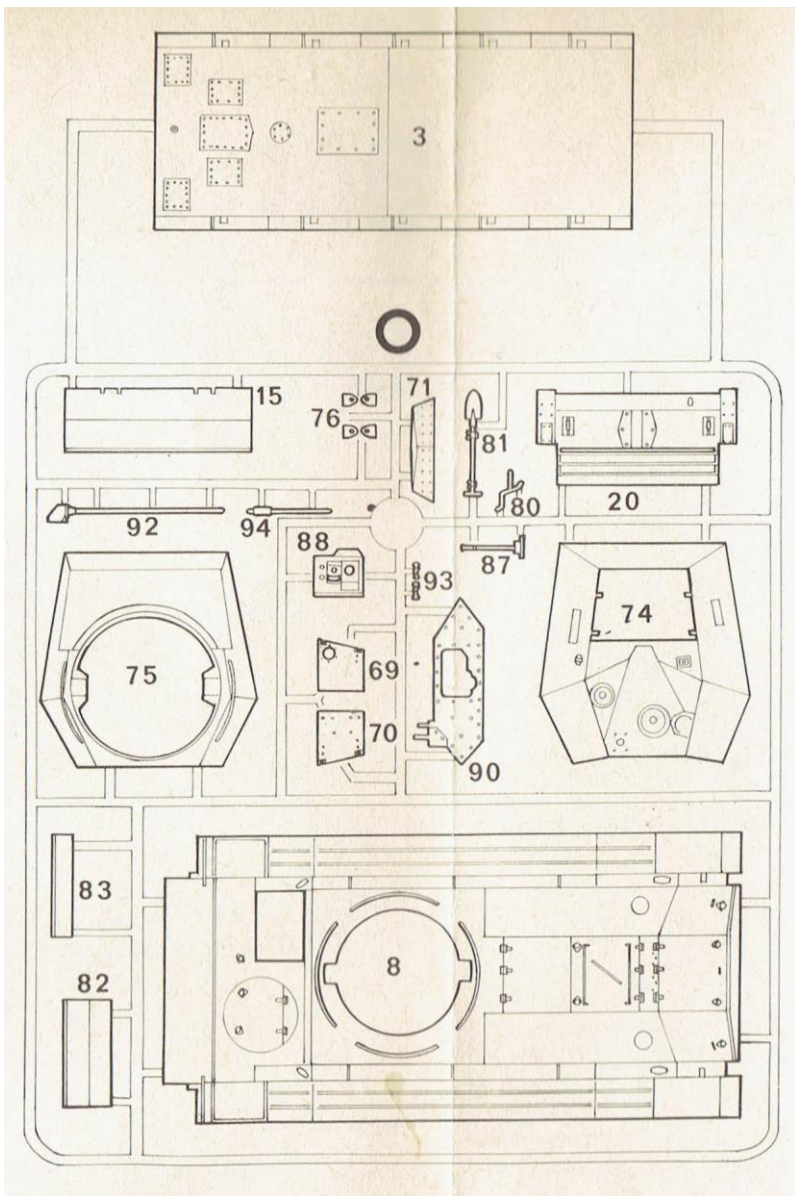

2 8-8

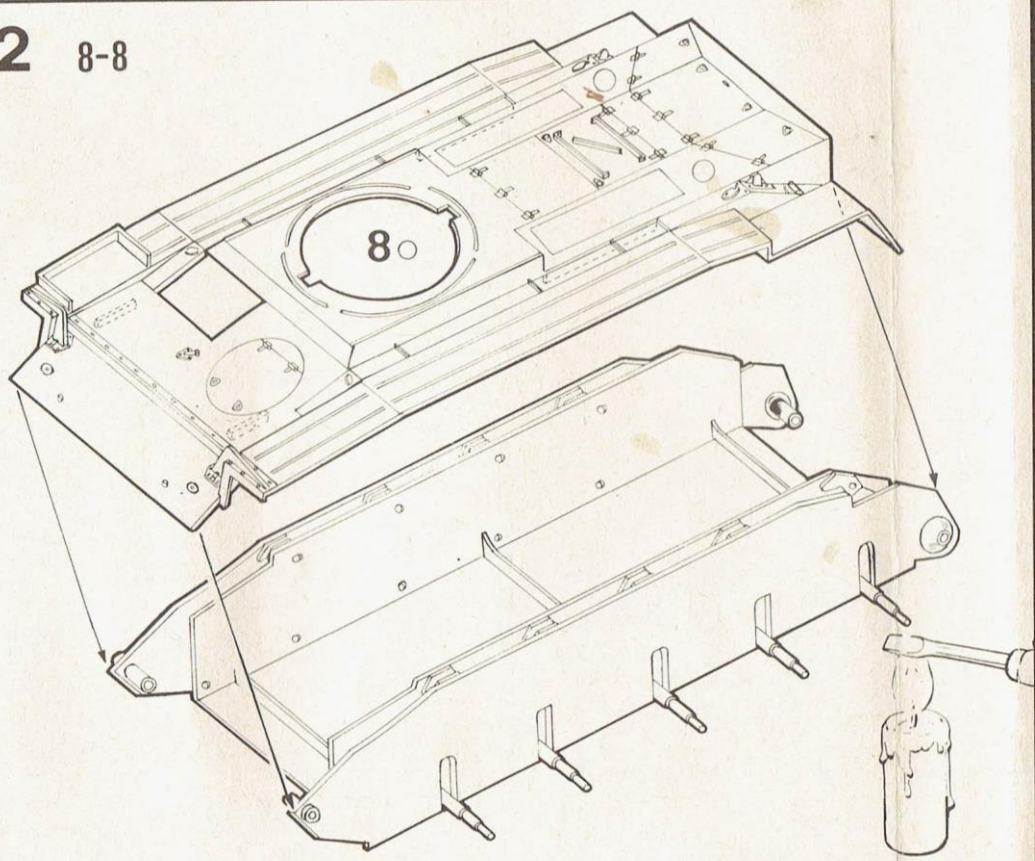

Do po avere montato la

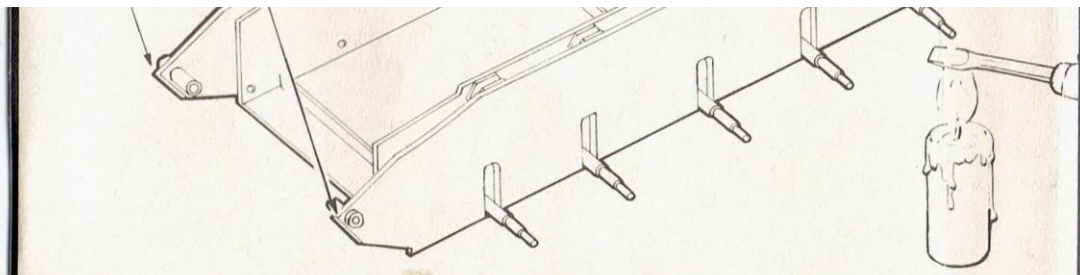

6  
30

**3** 9-17

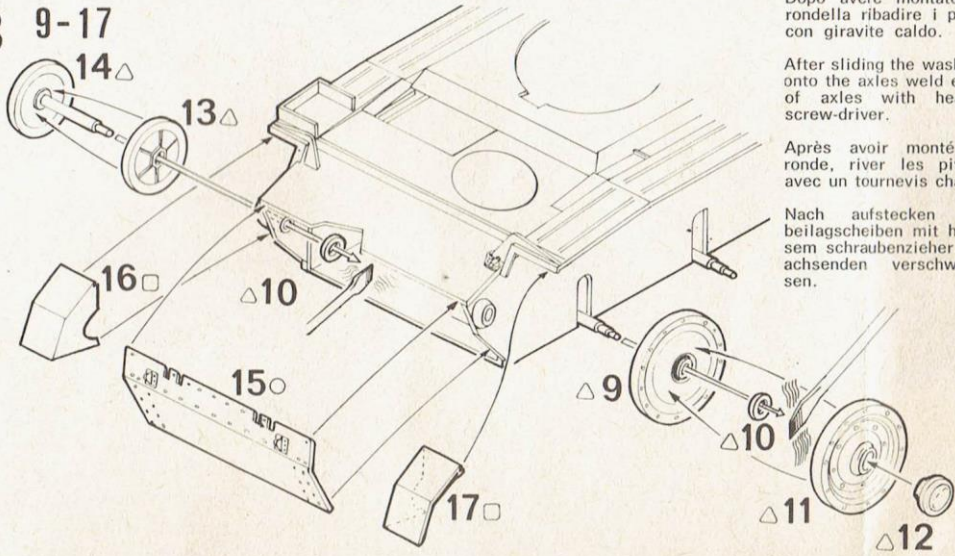

Dopo avere montato la rondella ribadire i perni con giravite caldo.

After sliding the washers onto the axles weld ends of axles with heated screw-driver.

Après avoir monté la ronde, river les pivots avec un tournevis chaud.

Nach aufstecken der beilagscheiben mit heissem schraubenzieher die achsenden verschweissen.

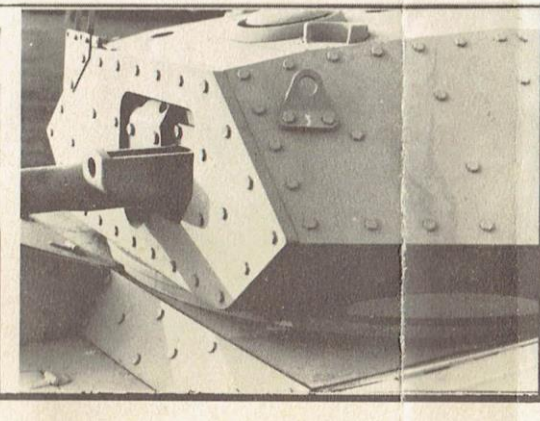
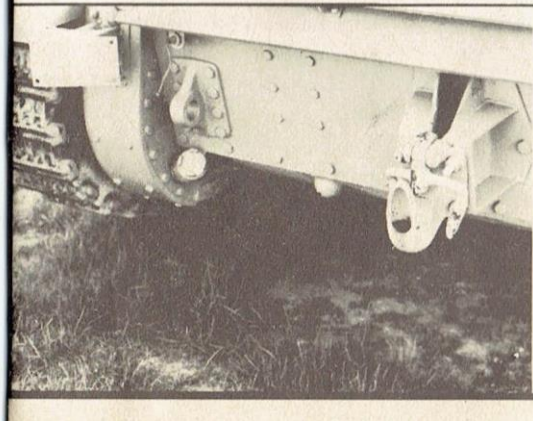

**4** 18 - 20

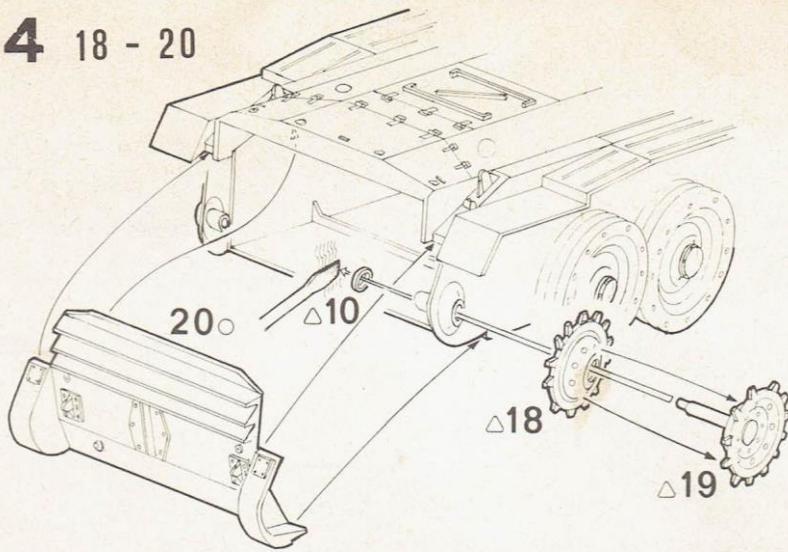

**5** 21-29

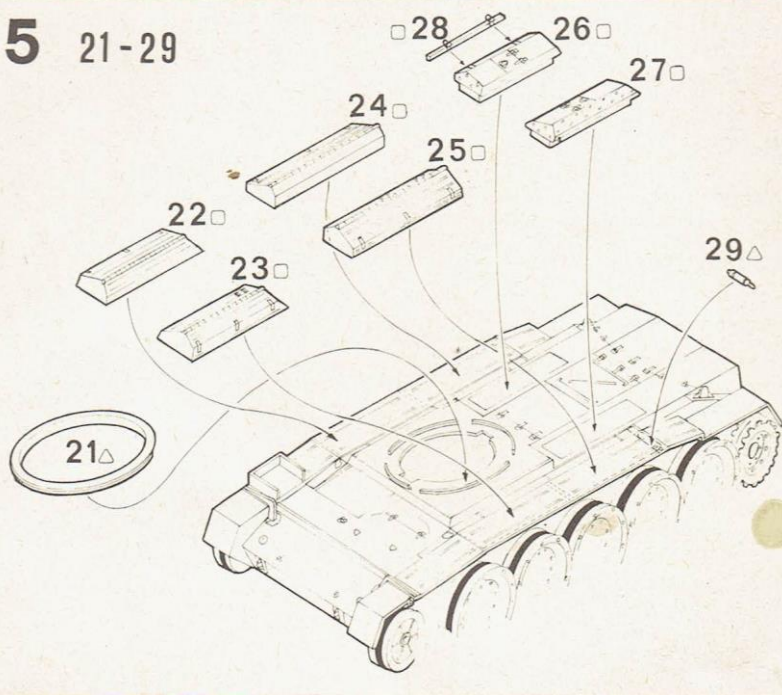

6

30 - 44

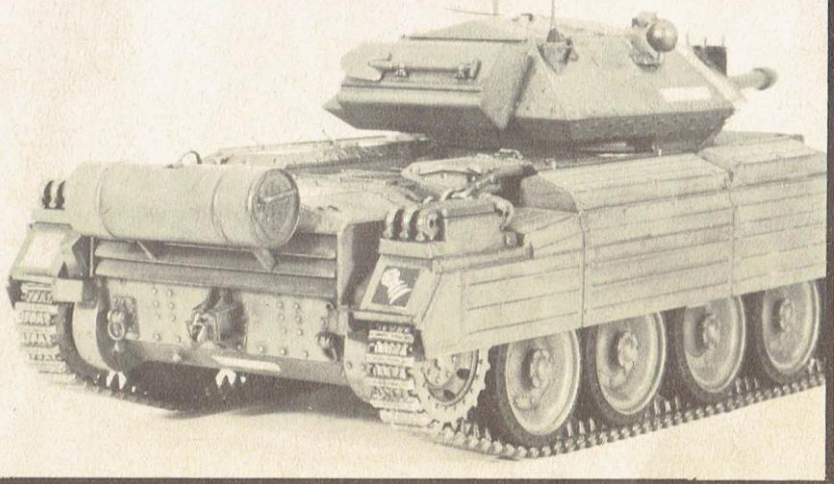
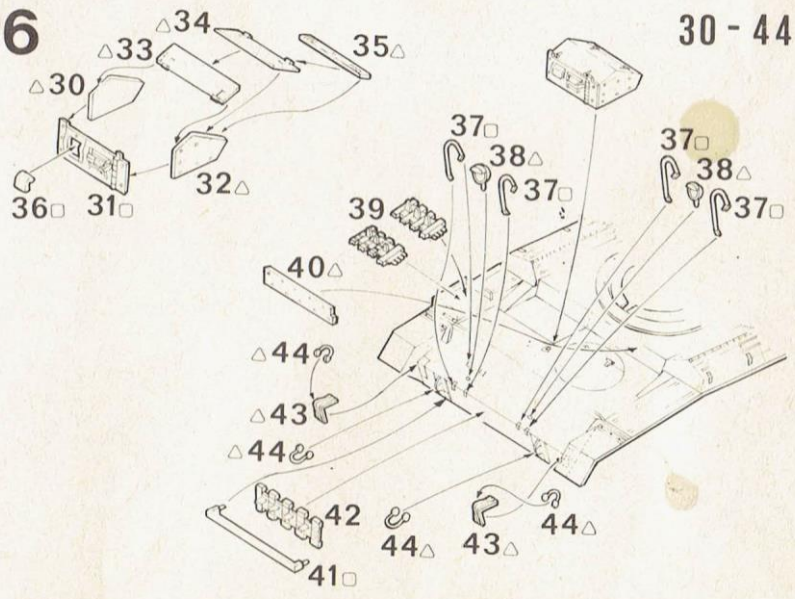



**7** 45 - 56

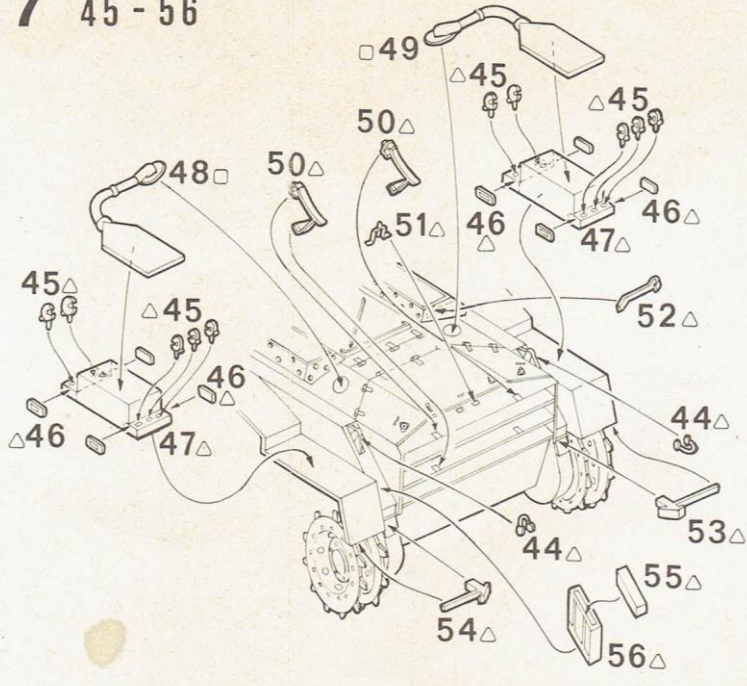

**8** 57-66

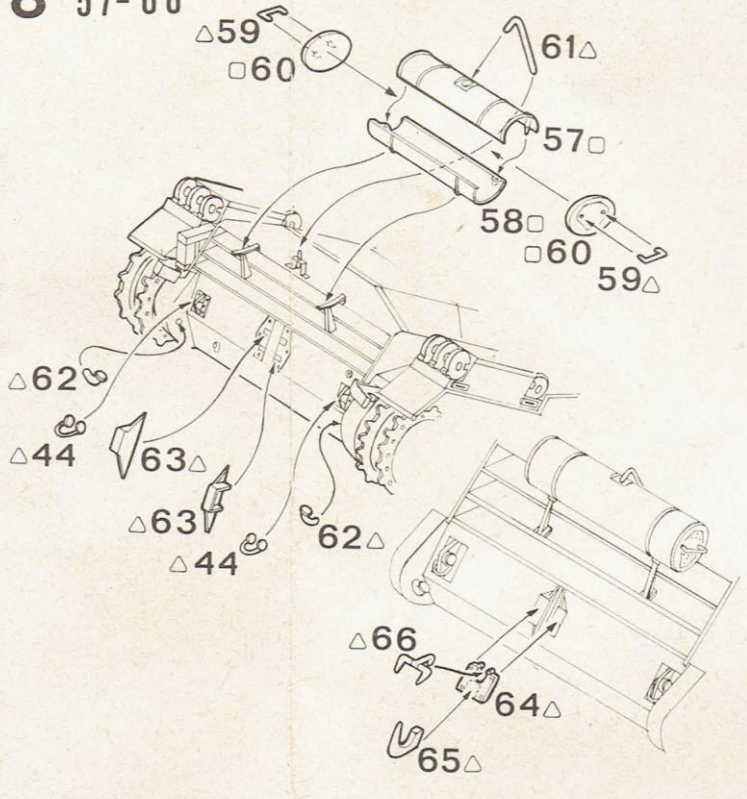

9

67-84

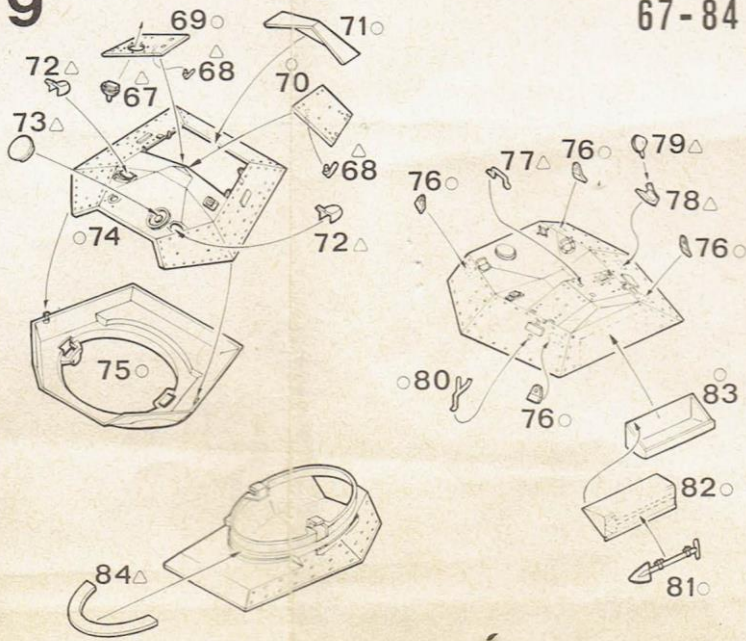

10 85-91

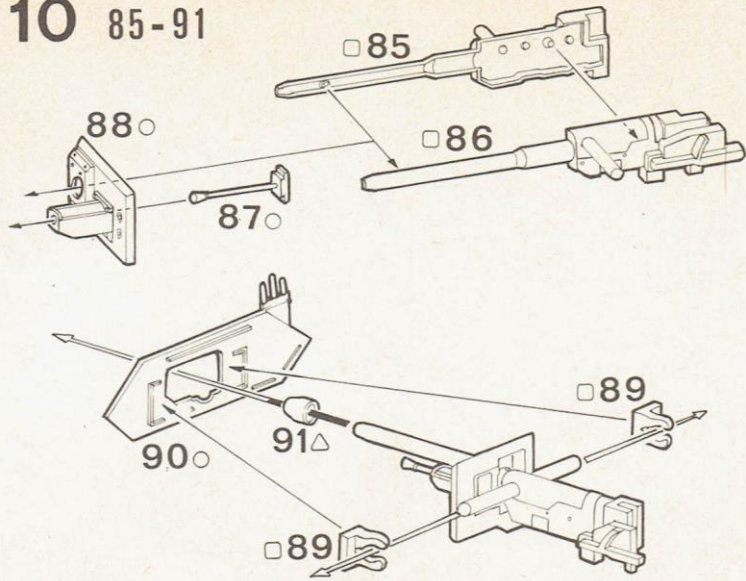

11 92-96

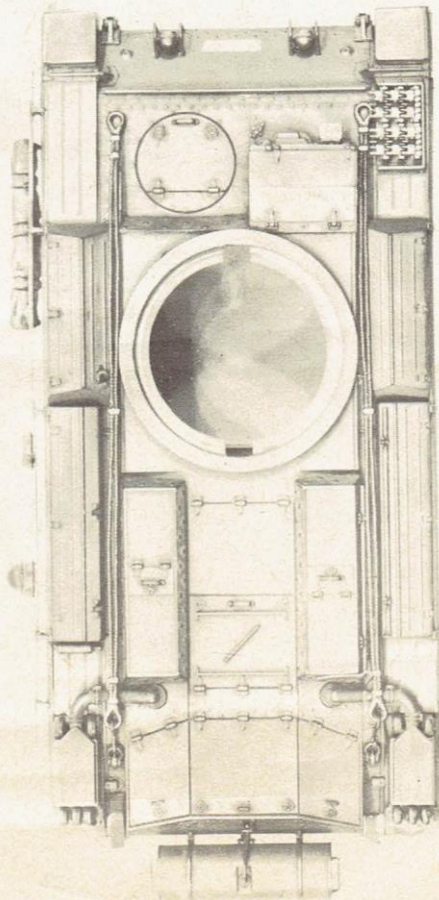
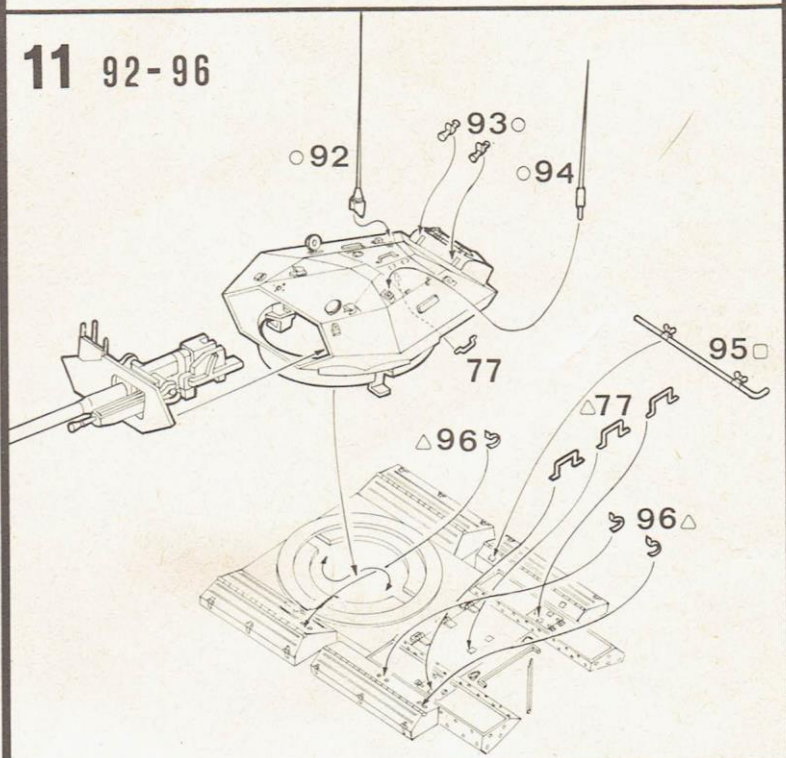

# 12

97 - 104

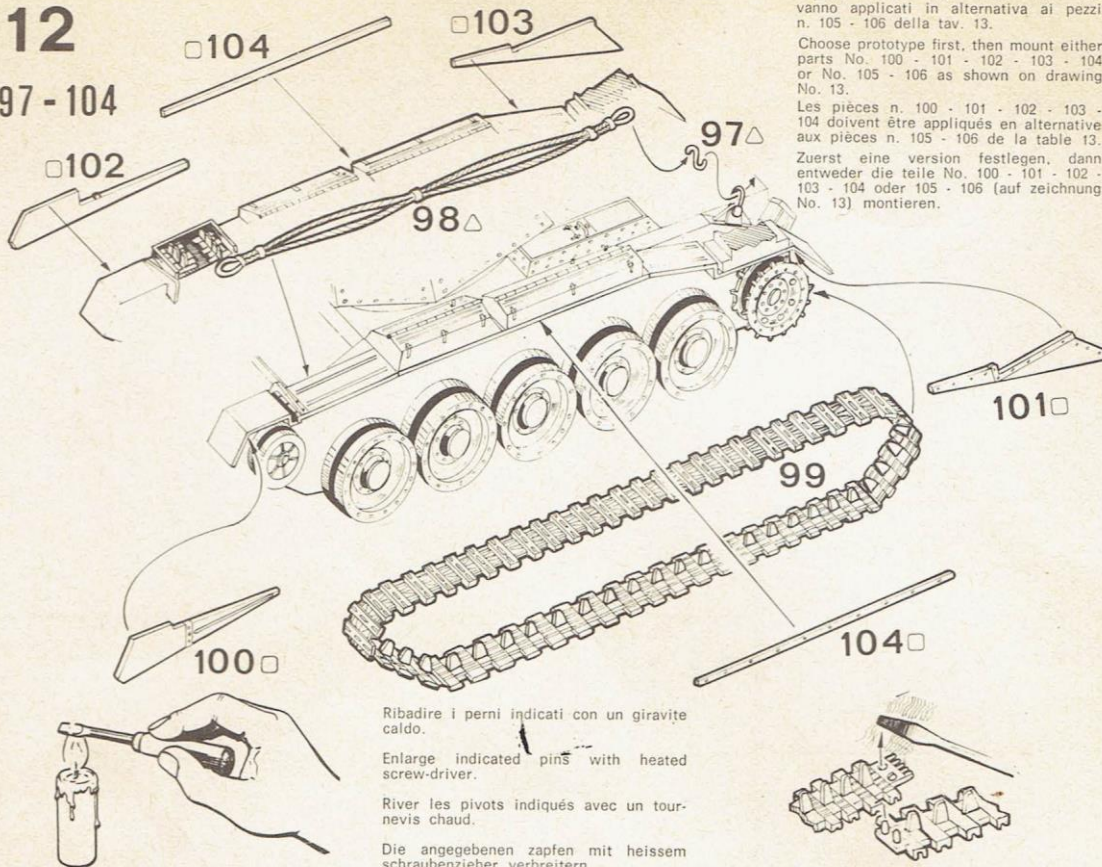

I pezzi n. 100 - 101 - 102 - 103 - 104 vanno applicati in alternativa ai pezzi n. 105 - 106 della tav. 13.

Choose prototype first, then mount either parts No. 100 - 101 - 102 - 103 - 104 or No. 105 - 106 as shown on drawing No. 13.

Les pièces n. 100 - 101 - 102 - 103 - 104 doivent être appliqués en alternative aux pièces n. 105 - 106 de la table 13.

Zuerst eine version festlegen, dann entweder die teile No. 100 - 101 - 102 - 103 - 104 oder 105 - 106 (auf zeichnung No. 13) montieren.

Ribadire i perni indicati con un giravite caldo.

Enlarge indicated pins with heated screw-driver.

River les pivots indiqués avec un tournevis chaud.

Die angegebenen zapfen mit heissem schraubenzieher verbreitern.

# 13 105-110

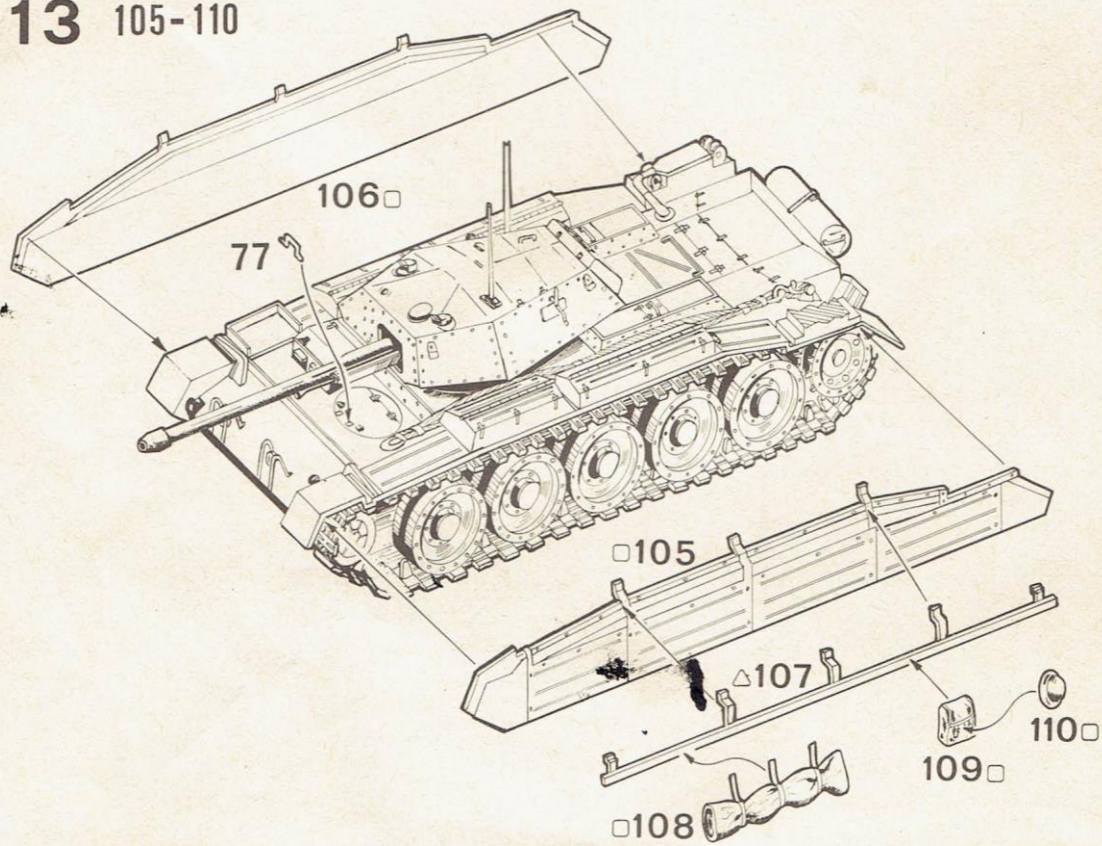

# 14 111 - 124



Per applicare le decalcomanie bagnare il foglio in acqua e farle scivolare sul modello.

To apply transfers cut out designs, dip into water and slide into position.

Pour appliquer les décalcomanies tremper la planche dans l'eau puis glisser chaque sujet sur le modèle:

Abziehbilder ins Wasser tauchen und am Modell anbringen.



NERO  
BLACK  
NOIR  
SCHWARZ

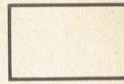

GIALLO SABBIA  
SAND YELLOW  
JAUNE SABLE  
SANDGELB



VERDE  
GREEN  
VERTE  
DUNKEL



TERRA SCURO  
DARK EARTH  
TERRE FONCEE  
DUNKLERDE

SCHEMI DIVERSI DI COLORAZIONE

PAINT SCHEMES

BEMALUNGSMÖGLICHKEITEN

SCHEMAS DIFFERENTS DE COLORATION

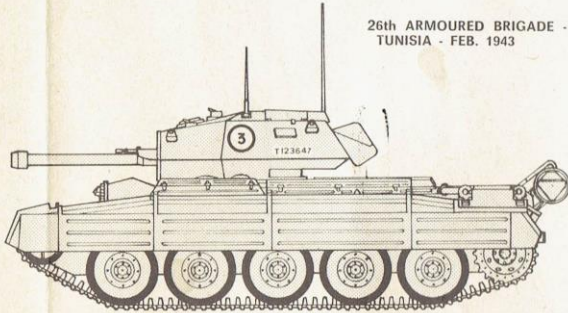

26th ARMoured BRIGADE - 6th ARMoured DIVISION  
TUNISIA - FEB. 1943

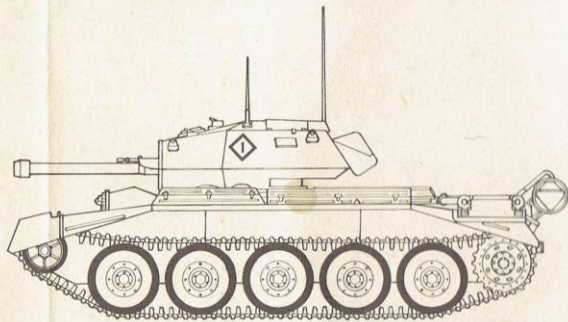
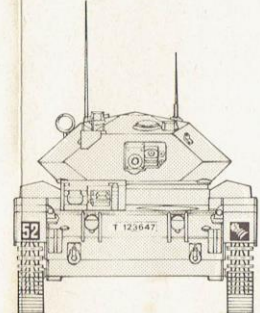
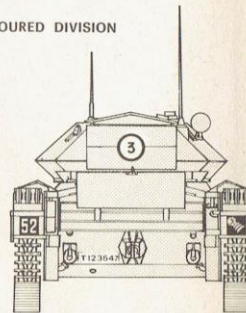

9th QUEENS ROYAL LANCERS / 2nd ARMoured BRIGADE  
1st ARMoured DIVISION / X CORPS / 8th ARMY EL ALAMEIN - NOV. 1942

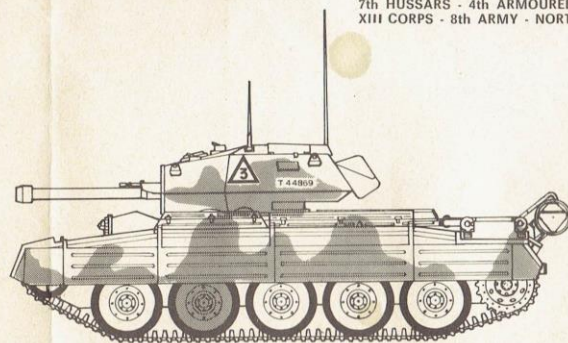
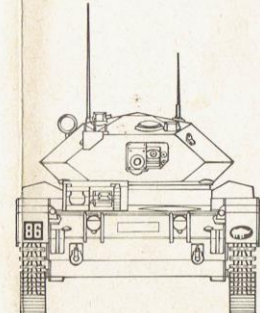
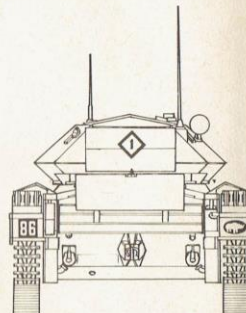

7th HUSSARS - 4th ARMoured BRIGADE - 7th ARMoured DIVISION  
XIII CORPS - 8th ARMY - NORTH AFRICA NOV. 1942

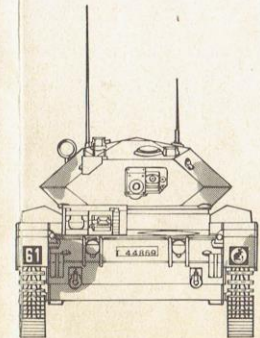
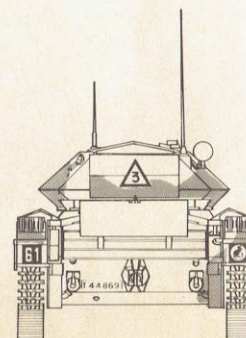
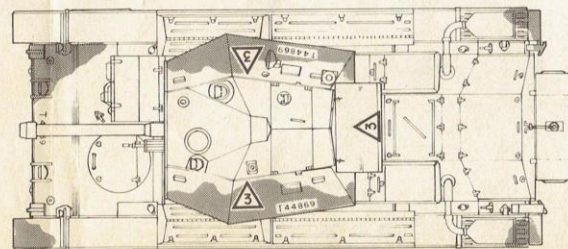
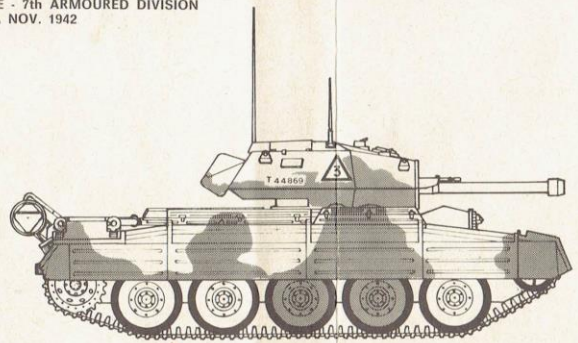

①

②

③

④

NERO  
BLACK  
NOIR  
SCHWARZ

KAKI  
KHAKI

KAKI SCURO  
DARK KHAKI  
KAKI FONCE  
DUNKELKHAKI

CUOIO MARRON  
BROWN LEATHER  
CUIR MARRON  
BRAUNES LEDER

