

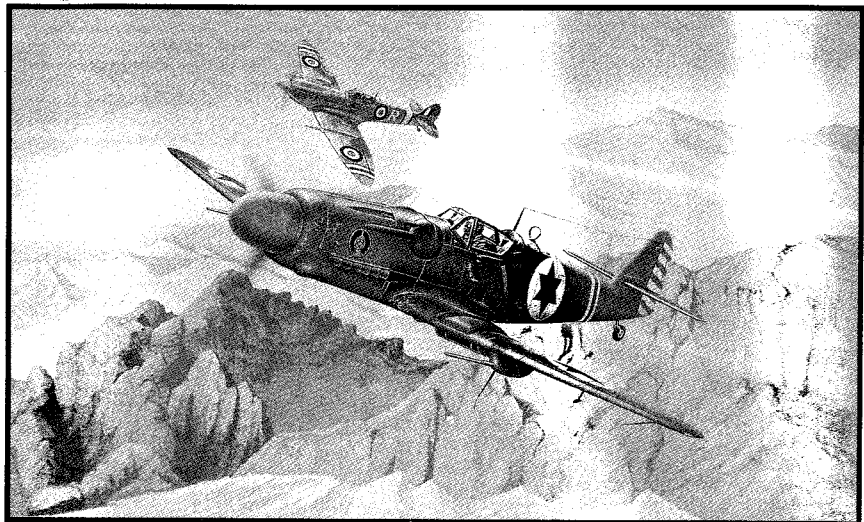

code P3
RLM-65
(Beide 7014)

Cushman Bismar



יִשְׂרָאֵלִי AVIA

HCI540 • 1:48 • Avia S-199 "Israeli Knife"

Kit features: detailed cockpit • landing gear • precise moldings • authentic markings.

Particularités du kit: • l'intérieur détaillé • train d'atterrissage très détaillé • moulage précis • les marques authentiques.

Caratteristiche del modello: • carlinga dettagliata e carrello di atterraggio • dettagli incisi • decals autentici.

Der Bausatz enthält: • detailliertes Cockpit und Fahrwerk • fein eingravierte Details • authentische Abziehbilder.

Características del kit: • se detallan la cabina del piloto y el aterrizador • marcas auténticas.

Gene...
RCM...
1:48

wholes - Pioneer Gray

COLOR	FLOQUIL CLASSIC**	HUMBROL**	TESTORS MODELMASTER**
Gray RLM 02	Ger. RLM Gray (02) 303271	Beige Green 90*	n/a
Israeli Camouflage Blue	Israeli Early Camo Blue 303313	Matt RAF Blue 96*	n/a
Israeli Camouflage Tan	Israeli Early Camo Tan 303315	n/a	n/a
RAF Middlestone	Br. Middlestone 303153	Matt Pale Stone 121*	Dark Tan 1742*
RAF Medium Sea Gray	Br. Sea Gray Med. 303151	Matt Sea Gray 165	Neutral Gray 1725*
FS13538 Yellow	Yellow 303269	Insignia Yellow 154	Insignia Yellow* 1708
FS31136 Red	Early British Red 303059	Insignia Red 153	Insignia Red 1705

*Approximate Match. **Some paints may not be available in your country. Please check with your local hobby shop for substitute colors.

cyanoacrylate glue coller cyanoacrylate Cyanoacrylate Kleben incollare cyanoacrylate pegar cyanoacrylate	cut couper schneiden tagliare cortar	bend plier sich biegen piegare doblar	file / sand ponce verspachteln levigare lijar	weight a lester Gewicht zavorra lastre	drill or pierce percer bohren forare agujerear	two deux zwei dos
painting instructions mode d'emploi Anleitungen der Farben istruzioni per la verniciatura instrucciones sobre la pintura	caution! attention! vorsichten! attenzione! atención	alternative en option Alternativ alternativo alternativa	cement coller kleben incollare pegar	paint peindre bemalen verniciare pintar	decal decalcomania Abziehbild decalcomania calcomanias	no! no! nein! no! ¡no!



Read This Before You Begin!

- study the assembly drawings
- each plastic part is identified by a number
- check the fit of each piece before cementing
- do not use too much cement to join parts
- model may be painted to match box illustration

Lisez Ce Qui Suit Avant De Commencer Le Montage!

- étudier les schémas d'assemblage
- chaque pièce plastique porte un numéro d'identification
- contrôler que chaque pièce soit bien conforme avant de la coller à sa place
- utilisez uniquement une colle spéciale pour polystyrène
- le model peut être peint conformément aux illustrations de la boîte

Vor Zusammenbau lesen sie bitte!

- studiere die Bauanleitung
- die Plastikteile sind gekennzeichnet durch ihre Nummern
- vor dem Kleben prüfe ob die Teile zusammenpassen können
- benutze nicht zuviel Klebstoff
- die Bemalung des Modells kann auf dem Becketbild zeigen

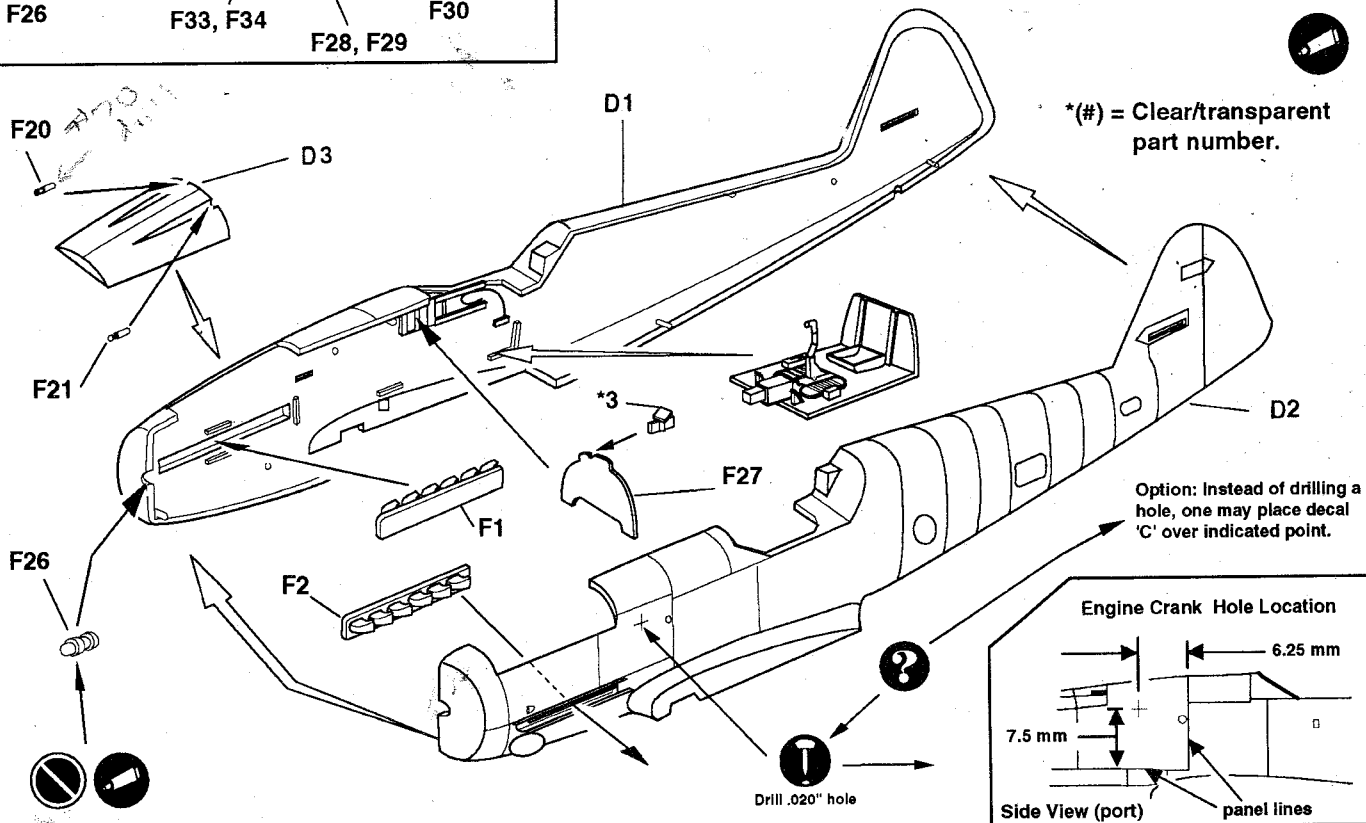
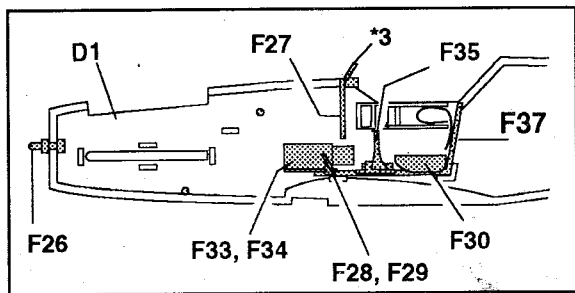
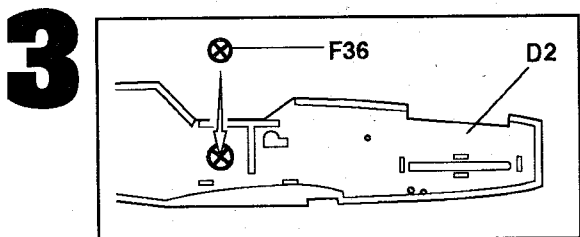
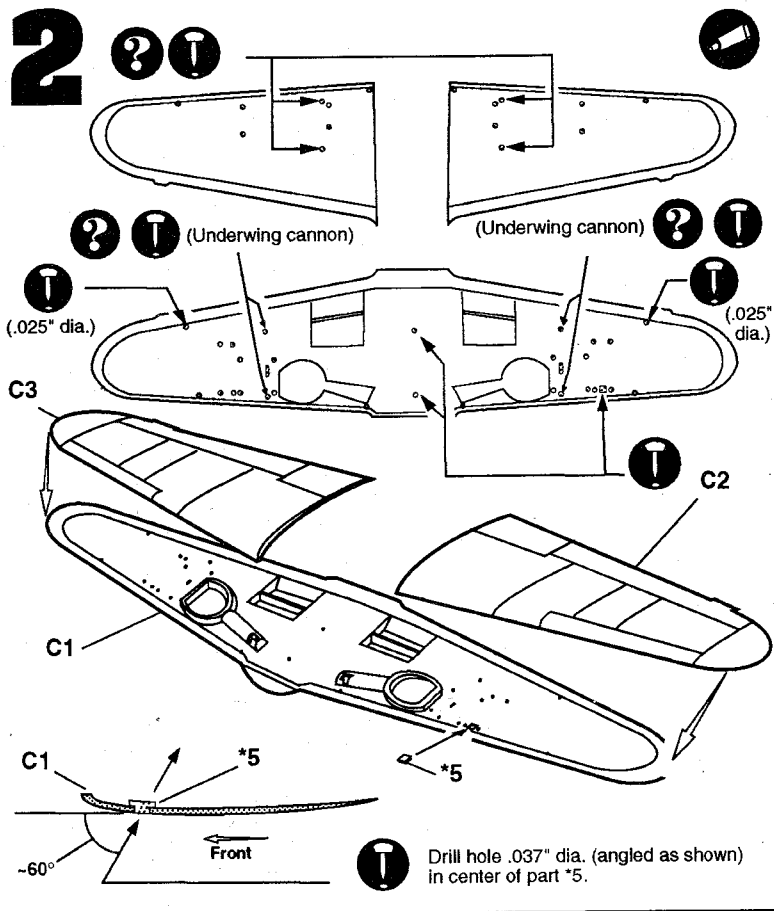
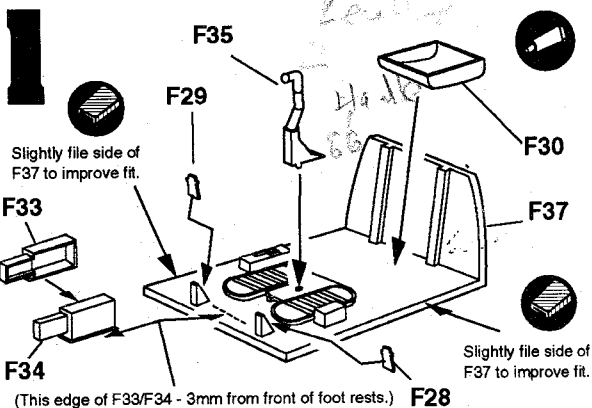

4

Side View

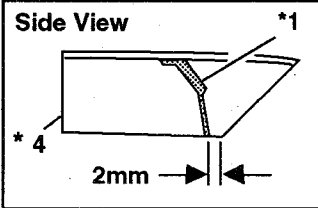

Minor filling might be needed in this area to improve fit.

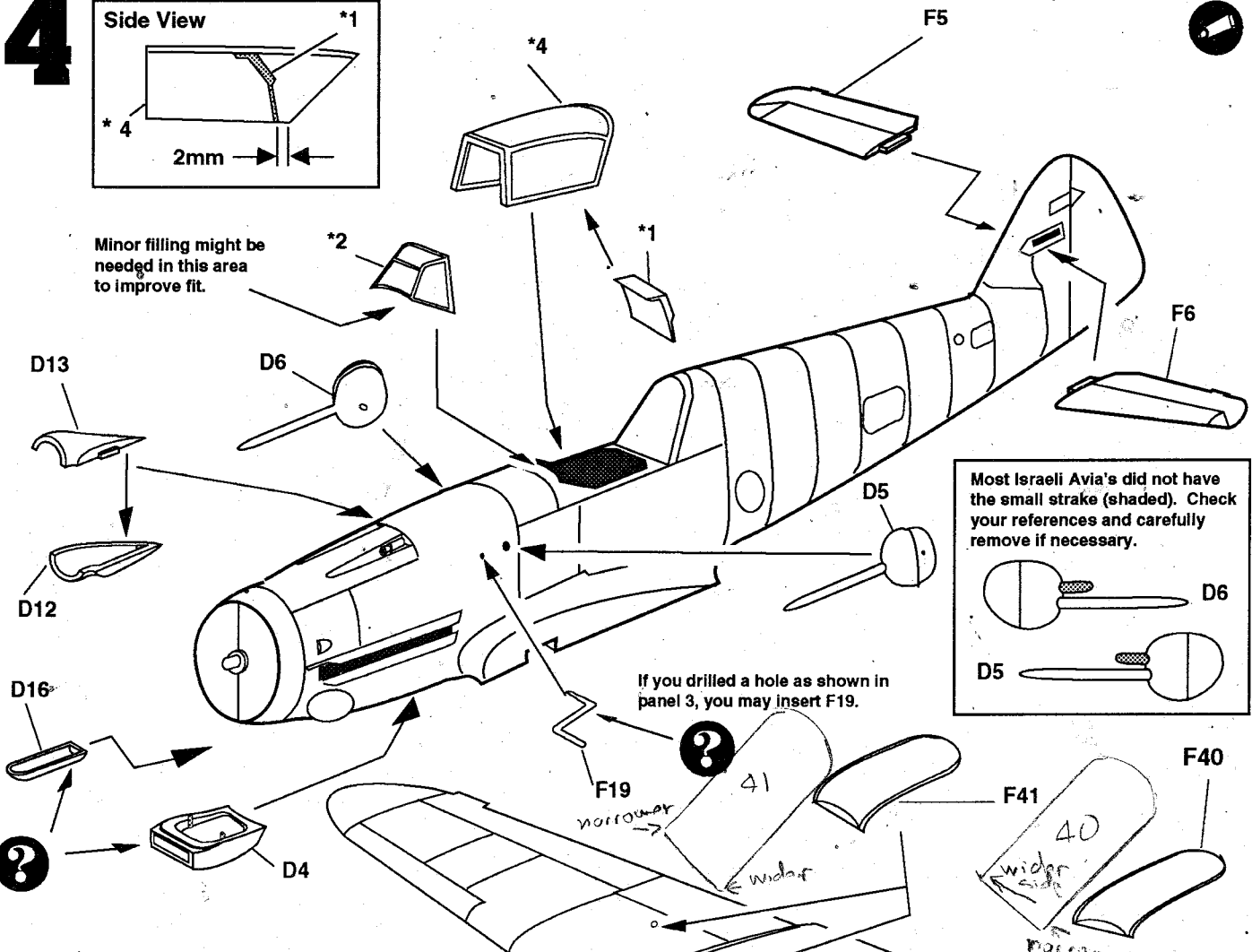

Most Israeli Avia's did not have the small stake (shaded). Check your references and carefully remove if necessary.

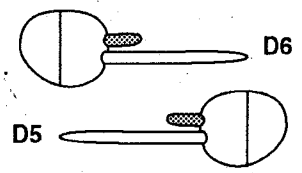

If you drilled a hole as shown in panel 3, you may insert F19.

Bottom View

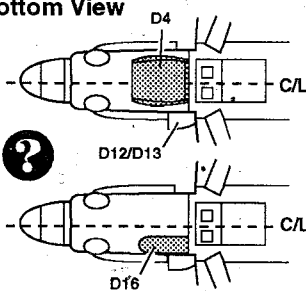

Remove mounting pegs and center D4 on the fuselage as shown, with its trailing edge even with the wing's leading edge.

Remove mounting peg and place D16 3mm from the fuselage center line as shown, with its trailing edge even with the wing's leading edge.

Aircraft with part D4 did not have part D16 and those with D16 did not have D4. Check your references carefully.

5

Front View

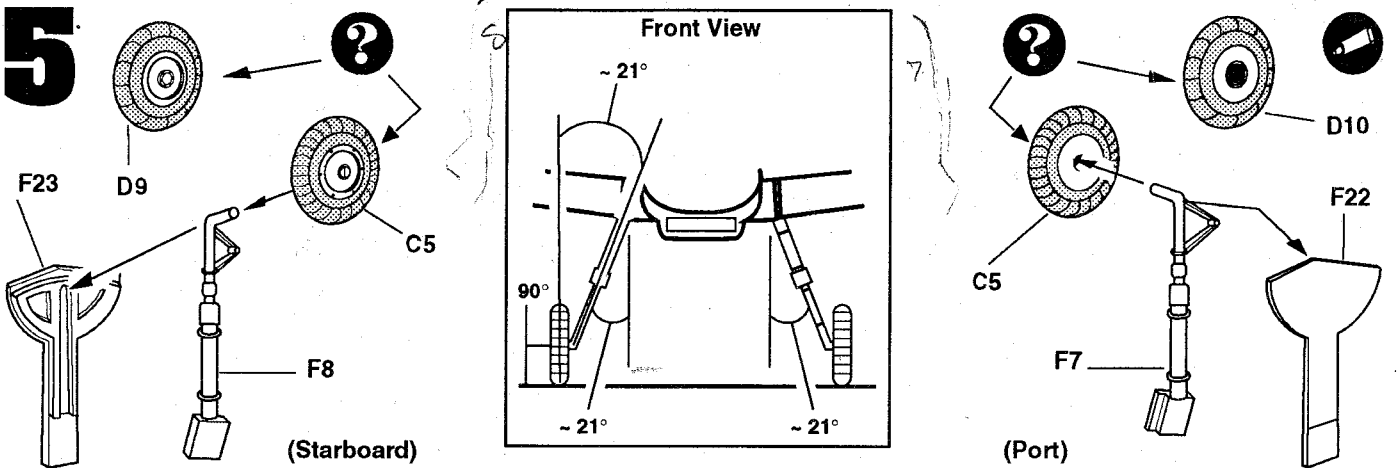

6

F42 (starboard)
F45 (port)

F44 (port)
F43 (starboard)

#68
drill bit

x2

(F14, F16, F17)

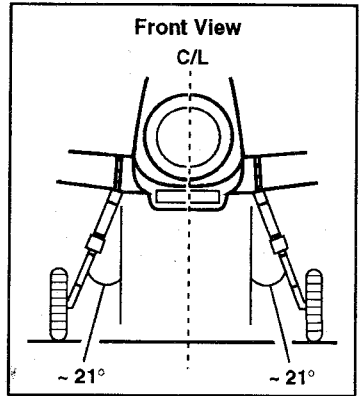
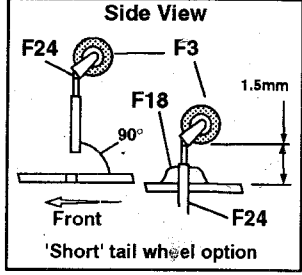
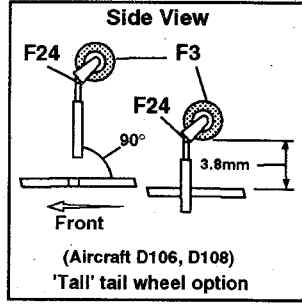
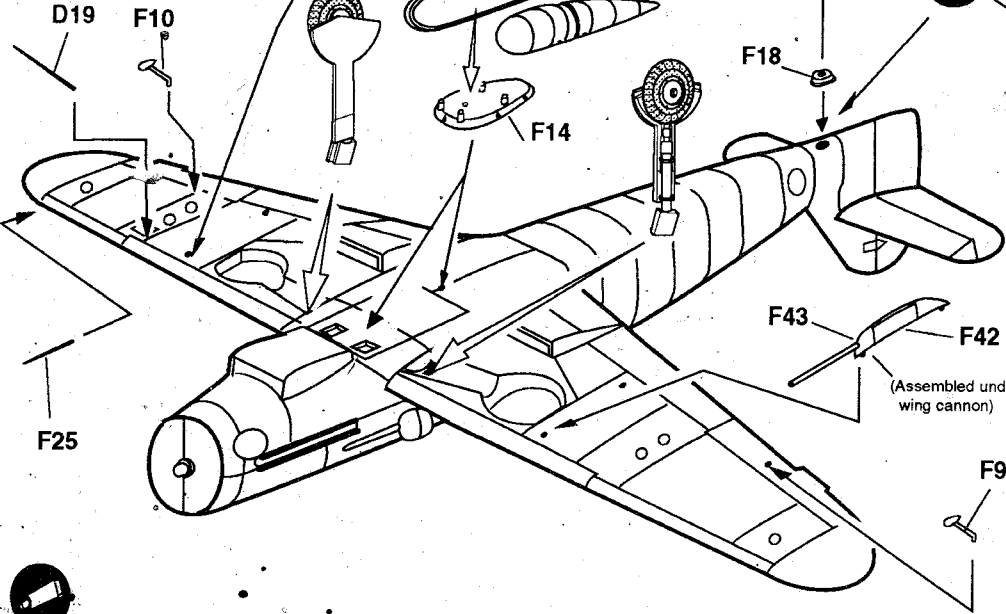
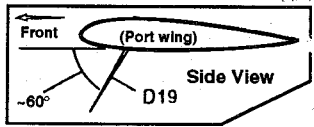

7

F11

F4

F12

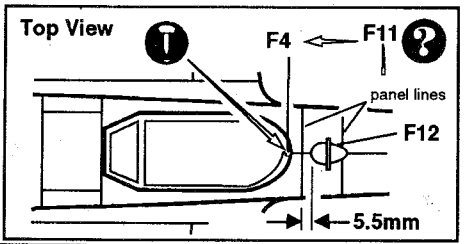
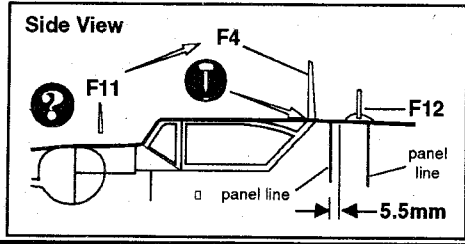
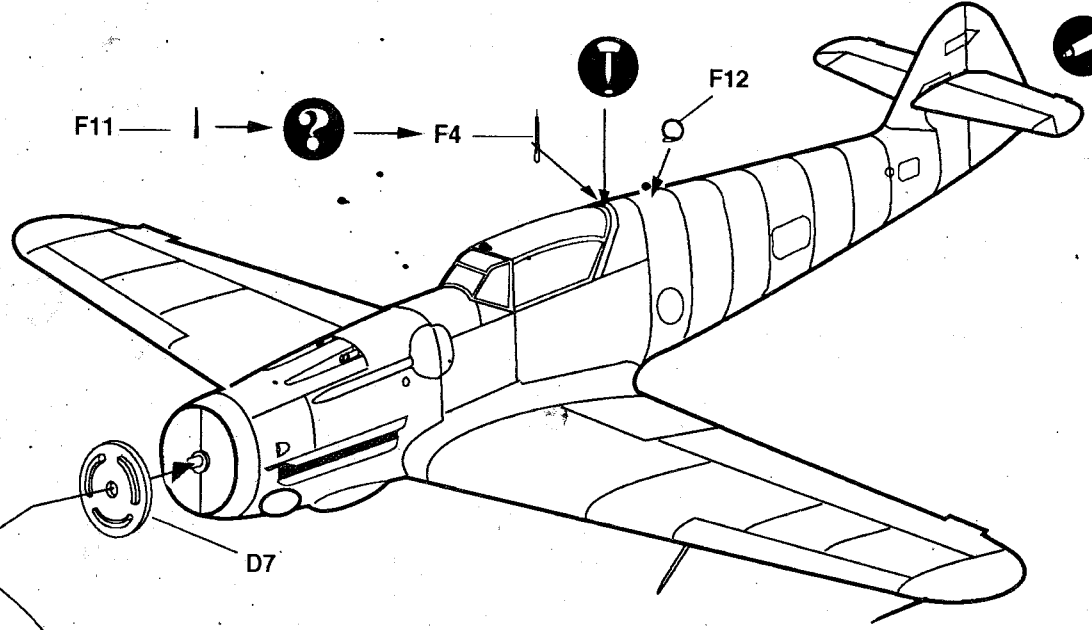
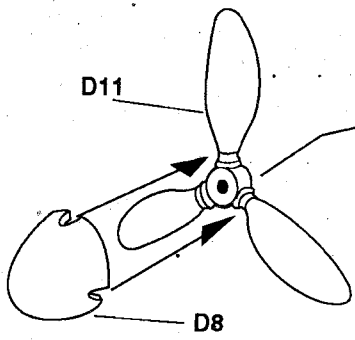

Israeli Avia

Markings • Appliques • Stencils •



paint
peindre
bemalen
vernicciare
pintar

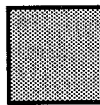

RLM 02
gray-green
gris-vert
Graugrün
griggio-verde
gris-verde

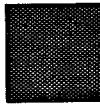

FS21136
red
rouge
Rot
rosso
rojo



FS25053
blue
bleu
Blau
azurro
azul

**Israeli S-199's flown by Modi Alon,
cdr., 101 Sqn., Tel Aviv, 3 June 1948**
"מסרשמיט" לשירות אויר

We are proud to present the first accurate markings for Israeli military Avias ever offered. These include correct serial configurations with the Hebrew letter "D" ("dalet(h)" / "ד") — not "T," as often depicted. According to Chayil Ha'vir sources, though, fuselage band colors were white/blue/white. But we have also supplied an alternate white/red/white fuselage stripe sometimes reported. An ironic sidenote: Israeli Avias, though manufactured in Czechoslovakia, were called "Messerschmitts" in Chayil Ha'vir service!



decal
decalcomania
Abziehbild
decalcomania
calcomanías

Many thanks to Bill Norton and David Ben-Adom for their help in researching and preparing this color & markings guide

Some details omitted for clarity

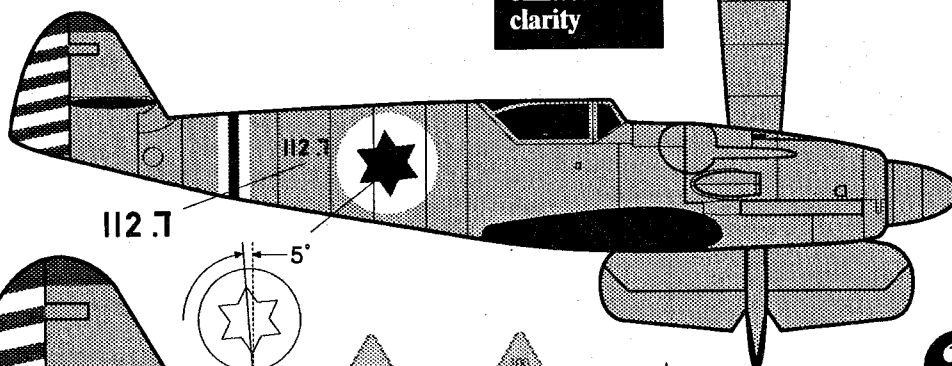
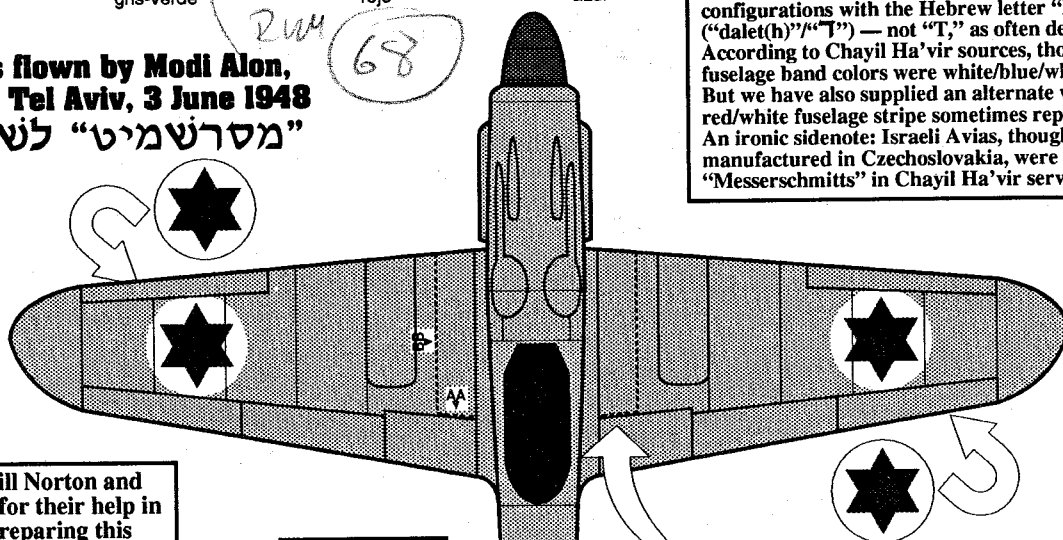

cut
couper
schneiden
tagliare
cortar



Some Israeli sources report "arrow" & "step" this side. Czech sources say NO "arrow" & "step" this side.

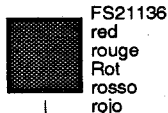
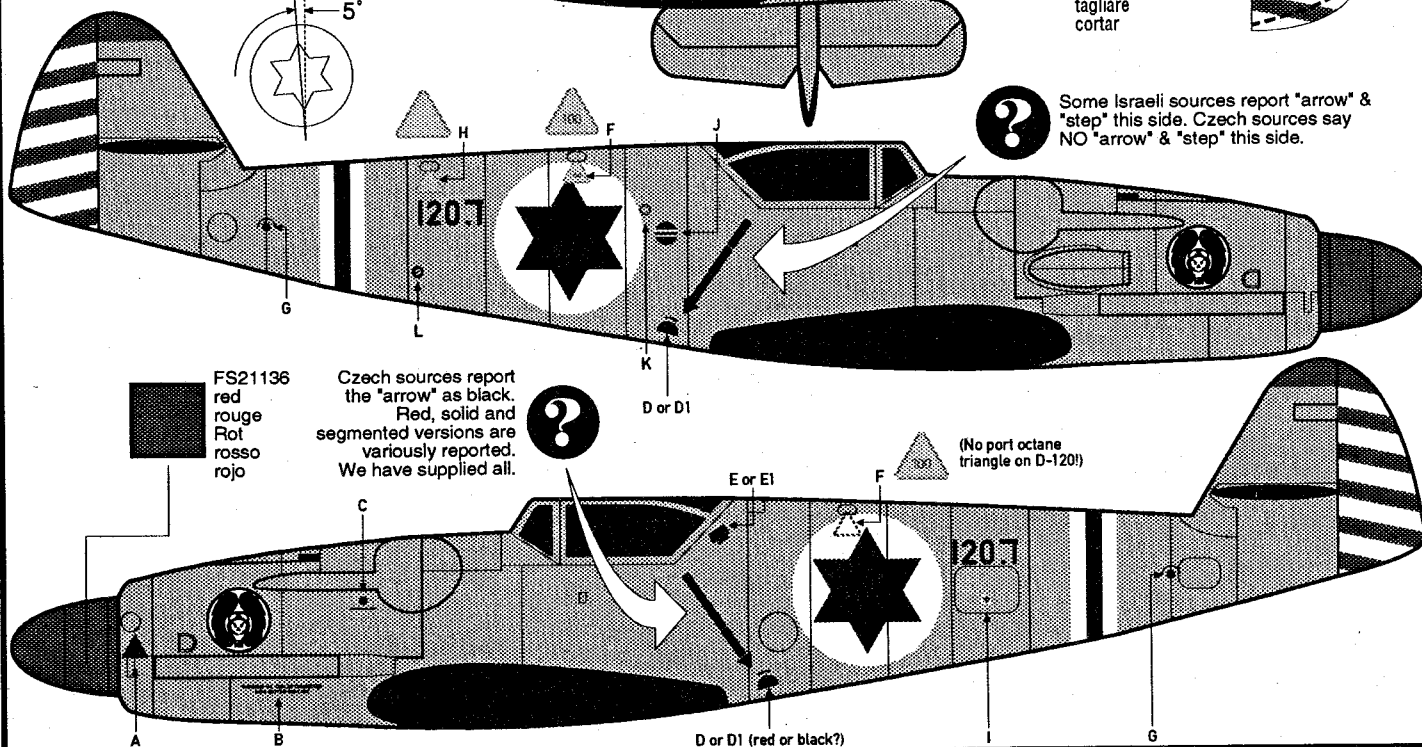

FS21136
red
rouge
Rot
rosso
rojo

Czech sources report the "arrow" as black. Red, solid and segmented versions are variously reported. We have supplied all.

(No port octane triangle on D-120)

Israeli Avia

Markings • Appliques



paint
peindre
bemalen
verniciare
pintar

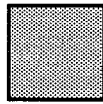

RLM 02
gray-green
gris-vert
Graugrün
griggio-verde
gris-verde



Israeli or FS25053
camo blue
bleu bleu
Blau Blau
azurro azul
azul



decal
decalcomania
Abziehbild
decalcomania
calcomanías

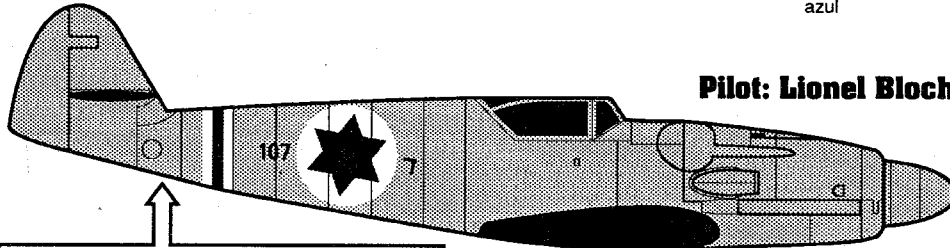

Pilot: Lionel Bloch, 101 Sqn., 10 July 1948

Starboard markings are conjectural. Typical 1948 Israeli practice placed the Hebrew "D" ("dalet(h)"/"ד") to the RIGHT of the fighter's numerical code. We think D-107 looked thus.

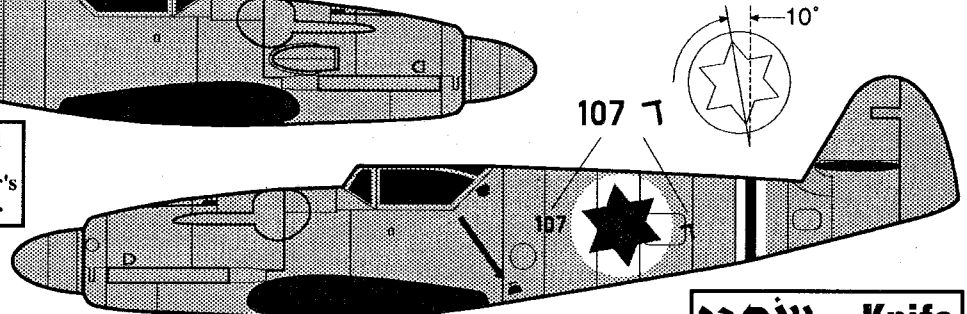

שָׁפִין = Knife

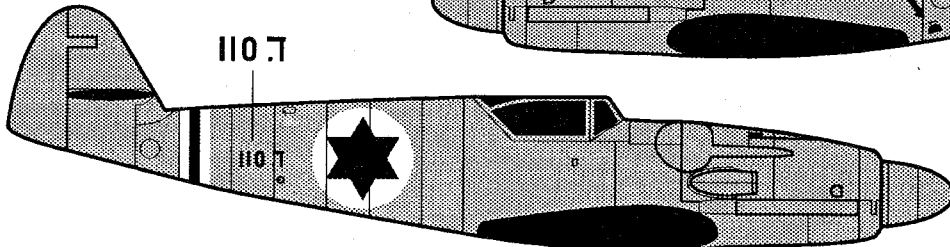

Pilot: Eddie Cohen, 101 Sqn., k.i.a., 29 May 1948

Delivered in a "gray-green" scheme, Israeli Avias also wore a two-tone scheme of desert tan (probably captured RAF Middlestone) above, with blue-gray (probably RAF med. sea gray or even PRU blue) beneath.

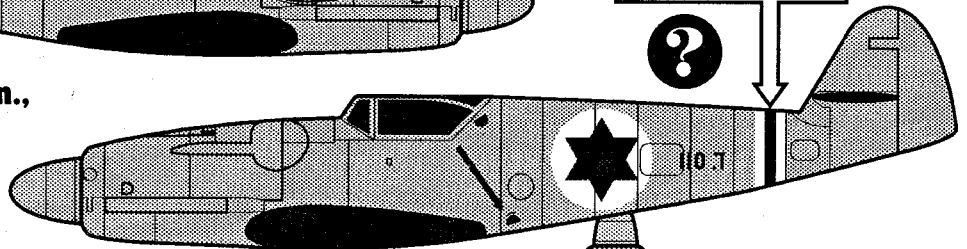

Probable fuselage band position. (Port markings conjectural.)

Israeli S-199 no. 1904, 105 (OTU) Sqn., ca. 1950



cut
couper
schneiden
tagliare
cortar

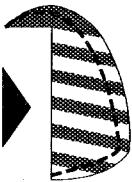

Camouflaged Avia preserved in 101 Sqn. markings (ca. 1950) outside a major Israeli air base. Paint matches are based on color photos of Heyl Ha'Avir warplanes of the early 1950's.

small Sqn badges on preserved example only

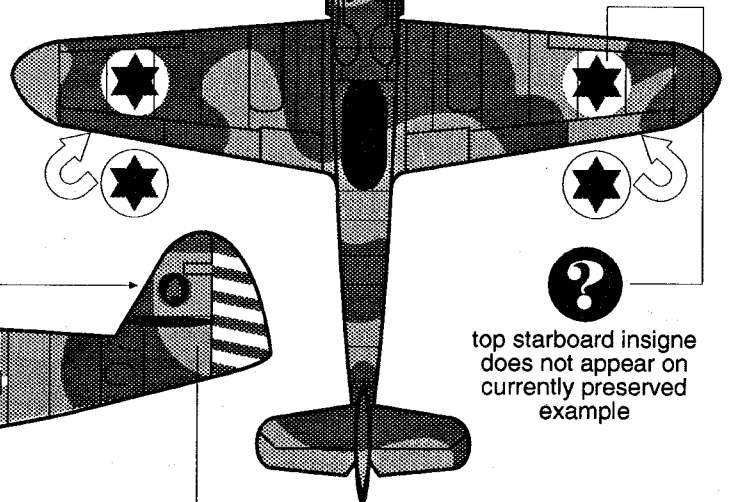
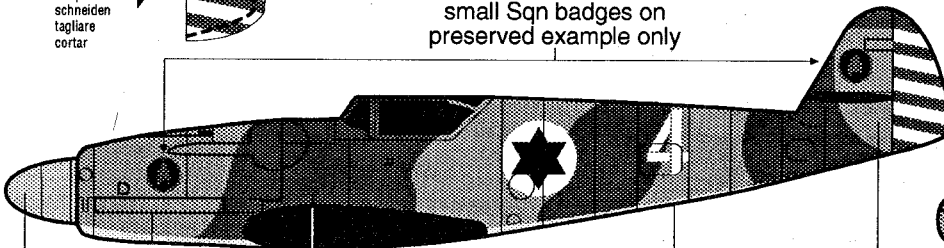

top starboard insigne does not appear on currently preserved example

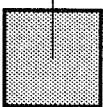

FS13538
yellow
jaune
Gelb
giallo
amarillo

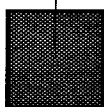

Israeli camou
dark blue
bleu foncé
Dunkelblau
azurro scuro
azul obscuro

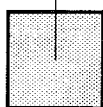

RAF Med. Sea
gray
gris
Grau
griggio
gris

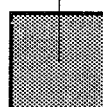

Israeli or camouflaged
tan
terre
Hellbraun
giallo
amarillo

RAF Middlestone
tan
terre
Hellbraun
giallo
amarillo

Some details omitted for clarity