

Made in Italy

1:24 scale

No 3947

Scania R400 Streamline (Flat Roof)

EN

The Scania R-series Streamline is designed to meet the highest demands in terms of fuel economy, driver comfort and reliability. The unique style of the exterior is combined with new exceptional interiors offer exceptional driver comfort and a wide range of choices of colors and materials. Available with both V8 engines and online. Robust, responsive and efficient, the Scania V8 engines are built to carry out the toughest jobs. Our model is also completed by a decals sheet and an accurate sheet of metallic adhesive, already ready for the application, for a correct finishing of the tractor vehicle, exactly as in the real.

FR

La série R Scania Streamline est conçue pour répondre aux exigences maximales en termes d'économie de carburant, de confort du conducteur et de fiabilité. Le style extraordinaire de l'extérieur est combiné aux nouveaux intérieurs qui offrent un confort exceptionnel au conducteur et une vaste gamme d'options de coloris et de matériaux. Disponible aussi bien avec moteurs V8 qu'en ligne. Robustes, réactifs et efficaces, les moteurs V8 Scania sont fabriqués pour effectuer les travaux les plus difficiles. Notre kit comprend également une feuille de décalcomanies et une feuille précise d'adhésifs métallisés déjà prêts pour l'application, pour une finition correcte du véhicule tracteur, exactement comme le modèle réel.

IT

La serie R Scania Streamline è progettata per soddisfare le massime esigenze in termini di risparmio di carburante, comfort del conducente e affidabilità. Lo straordinario stile dell'esterno è abbinato a nuovi interni esclusivi che offrono un eccezionale comfort per il conducente e una vasta gamma di opzioni di colori e materiali. Disponibile con motori sia V8 che in linea. Robusti, reattivi ed efficienti, i motori V8 Scania sono costruiti per svolgere i lavori più impegnativi. Il nostro modello viene inoltre completato da un foglio decals e da un accurato foglio di adesivi metallizzati, già pronto per l'applicazione, per una corretta finitura della motrice, esattamente come in quello reale.

ES

La serie R Scania Streamline ha sido diseñada para satisfacer las exigencias de ahorro de combustible, comodidad del conductor y fiabilidad. El estilo extraordinario del exterior se combina con interiores nuevos y exclusivos, que ofrecen una comodidad excepcional para el conductor y una amplia gama de colores y materiales. Está disponible ya sea con motores V8 que en línea. Robustos, reactivos y eficientes, los motores V8 Scania se han fabricado para realizar trabajos que requieren mayor fuerza. Nuestro Kit comprende también dos hojas, una con calcomanías y una con adhesivos metalizados listos para la aplicación, para un perfecto acabado del camión, exactamente como el modelo original.

DE

Die Serie R Scania Streamline wurde entwickelt, um die höchsten Ansprüche in Bezug auf Kraftstoffverbrauch, Fahrkomfort und Zuverlässigkeit zu erfüllen. Der einzigartige Stil des Exterieurs wird kombiniert mit neuen exklusiven Interieurs: außergewöhnlicher Fahrerkomfort und eine breite Palette von Möglichkeiten an Farben und Materialien.. Erhältlich sowohl mit Achtzylinder-Motoren als auch mit Reihenmotoren. Die Achtzylinder-Motoren Scania sind solide, reaktiv und leistungsstark und daher geeignet, anspruchsvolle Arbeiten auszuführen. Unser Bausatz wird außerdem durch einen Bogen mit Abziehbildern und einem Bogen genau nachgebildeter Metallic-Aufkleber, für die Anwendung bereit, ergänzt; dadurch kann die Zugmaschine gemäß dem realen Modell mit dem korrekten Finish nachgebildet werden.

NL

De R Scania Streamline-reeks werd ontworpen om aan de hoogste vereisten te voldoen wat betreft brandstofbesparing, bestuurderscomfort en betrouwbaarheid. De buitengewone stijl van de buitenkant is gecombineerd met exclusieve, nieuwe interieurs die een uitzonderlijk comfort bieden voor de bestuurder en een ruim gamma mogelijkheden qua kleuren en materialen. Beschikbaar met V8- of lijnmotoren. De V8 Scania-motoren zijn robuust, reactief en efficiënt, ontworpen om de zwaarste belastingen het hoofd te bieden. Onze kit wordt bovendien vervolledigd met een aanbod decals en een uitgelezen aanbod gemetalliseerde stickers klaar om aan te brengen, voor een perfecte afwerking van de trekker, getrouw aan het werkelijke model.



- EN** **WARNING:** Model for adult collector age 14 and over
IT **ATTENZIONE:** Modello per collezionisti adulti di età superiore ai 14 anni
FR **ATTENTION:** Modèle pour modélistes de 14 ans et plus.
DE **ACHTUNG:** Modellbausätze Für Modellbauer über 14 Jahre.
NL **WAARSCHWING:** Geschikt voor 14 jaar en ouder.
ES **ATENCION:** Modelo para modelistas mayores de 14 años.

EN ATTENTION - Useful advice!

Study the instructions carefully prior to assembly. Remove parts from frame with a sharp knife or a pair of scissor and trim away excess plastic. Do not pull off parts. Assemble the parts in numerical sequence. Use plastic cement ONLY and use cement sparingly to avoid damaging the model. Black arrows indicate parts to be glued together. White arrows indicate on which frame the parts must be assembled WITHOUT using cement. These letters (A - B - C...) indicate on which frame the parts will be found. Paint small parts before detaching them from frame. Remove paint where parts are to be cemented. Crossed out parts must not be used.

IT ATTENZIONE - Consigli utili!

Prima di iniziare il montaggio studiare attentamente il disegno. Staccare con molta cura i pezzi dalle stampate, usando un taglia-balsa oppure un paio di forbici e togliere con una piccola lima o con carta vetro fine eventuali sbavature. Mai staccare i pezzi con le mani. Montarli seguendo l'ordine delle numerazioni delle tavole. Eliminare dalla stampata il numero del pezzo appena montato facendogli sopra una croce. Le frecce nere indicano i pezzi da incollare, le frecce bianche indicano i pezzi da montare senza colla. Usare solo colla per polistirolo. Le lettere (A - B - C...) ai lati dei numeri indicano la stampata ove si trova il pezzo da montare. I pezzi sbarrati da una croce non sono da utilizzare.

DE ACHTUNG - Ein nützlicher Rat!

Vor der Montage die Zeichnung aufmerksam studieren. Die einzelnen Montageeile mit einem Messer oder einer Schere vom Spritzling sorgfältig entfernen. Eventuelle Grate werden mit einer Klinge oder feinem Schmirgelpapier beseitigt. Keinesfalls die Montageeile mit den Händen entfernen. Bei der Montage der Tafelnummerierung folgen. Pfeile zeigen die zu klebenden Teile während die weissen Pfeile die ohne Leim zu montierenden Teile anzeigen. Bitte nur Plastikklebstoff verwenden. Die Buchstaben (A - B - C...) neben den Nummern zeigt auf welchem Spritzling der zu montierende Teil zu finden ist. Die mit einem Kreuz markierten Teile sind nicht zu verwenden.

FR ATTENTION - Conseils utiles!

Avant de commencer le montage, étudier attentivement le dessin. Détacher avec beaucoup de soin les morceaux des moules en usant un massicot ou bien un pair de ciseaux et couper avec une petite lame avec de papier de verre fin ébarbages éventuels. Jamais détacher les morceaux avec le mains Monter les en suivant l'ordre de la numération des tables. Eliminer de la moule le numéro de la pièce qui vient d'être montée, en le bifant avec une croix. Les flèches noires indiquent les pièces à coller, les flèches blanches indiquent les pièces à monter sans colle. Employer seulement de la colle pour polystyrol. Les lettres (A - B - C...) aux côtés des numéros indiquent la moule où se trouve la pièces à monter. Les pièces marquées par une croix ne sont pas à utiliser.

ES ATENCION - Consejos útiles!

Estudiar las instrucciones cuidadosamente antes de comenzar el montaje. Separar las piezas de las bandejas con un cuchillo afilado o un par de tijeras y retirar el exceso de plástico o rebada. No arrancar las piezas. Montar las piezas en orden numérico. Utilizar SOLAMENTE pegamento para plástico y en poca cantidad para evitar que se dane el modelo. Las flechas negras indican las piezas que se deben pegar juntas. Las flechas blancas indican las piezas que deben ensamblarse SIN usar pegamento. Las letras (A - B - C...) indican en que bandeja se encuentran las piezas. Pintar las piezas pequeñas antes de separarlas de la bandeja. Retirar la pintura de los lugares por donde se deban pegar las piezas.

RU ПРЕДУПРЕЖДЕНИЕ - важные!

ПЕРЕД ТЕМ, КАК ПРИСТУПИТЬ К СБОРКЕ, ВНИМАТЕЛЬНО ИЗУЧИТЬ ЧЕРТЕЖ. ОЧЕНЬ ОСТОРОЖНО ОТСОЕДИНЯТЬ РАСЧЕТНЫЕ ЭЛЕМЕНТЫ, ИСПОЛЬЗОВАТЬ ДЛЯ ЭТОГО КАНЦЕЛЯРСКИЙ НОЖ ИЛИ ПАРУ НОЖИЦ, СНИТЬ НЕРОВНОСТИ С ПОМОЩЬЮ ТОНКОГО ЛЕЗВИЯ ИЛИ С ПОМОЩЬЮ АБРАЗИВНОЙ БУМАГИ. НЕ ОТСОЕДИНЯТЬ ЭЛЕМЕНТЫ РУКАМИ. ВЫПОЛНИТЬ СБОРКУ СОГЛАСНО ПОРЯДКУ НУМЕРАЦИИ ТАБЛИЦ, УДАЛИТЬ ИЗ СПИСКА ТОЛЬКО ТО ЧТО СОБРАННУЮ ДЕТАЛЬ, ПЕРЕКЕРИВАЯ ЕЕ. ЧЕРНЫЕ СТРЕЛКИ УКАЗЫВАЮТ ДЕТАЛИ ДЛЯ СКЛЕИВАНИЯ, БЕЛЫЕ СТРЕЛКИ УКАЗЫВАЮТ ДЕТАЛИ, КОТОРЫЕ СОБИРАЮТСЯ БЕЗ КЛЕЯ. ИСПОЛЬЗОВАТЬ ТОЛЬКО КЛЕЙ ДЛЯ ПЕНОПЛАСТА. БУКВЫ (А - В - С...) НА ПРОНУМЕРОВАННЫХ СТОРОНАХ УКАЗЫВАЮТ ЛИСТ, ГДЕ НАХОДИТСЯ ДЕТАЛЬ. ПЕРЕКЕРНУТЫЕ ДЕТАЛИ НЕ ИСПОЛЬЗУЮТСЯ.

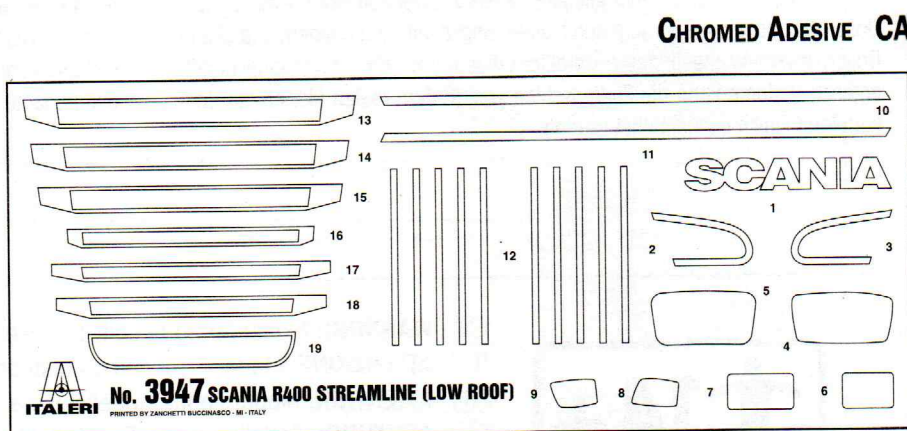
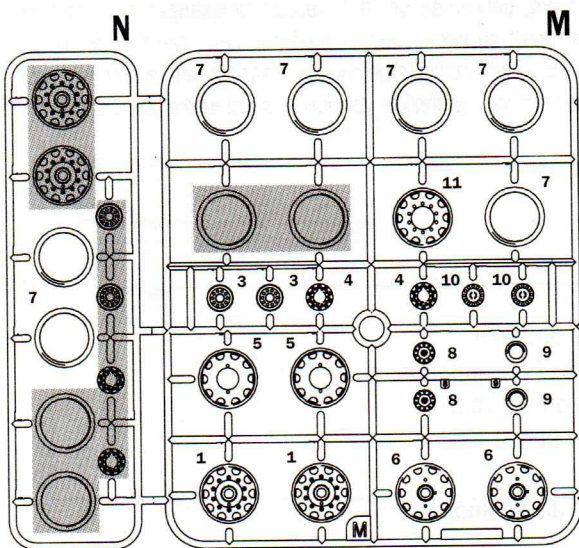
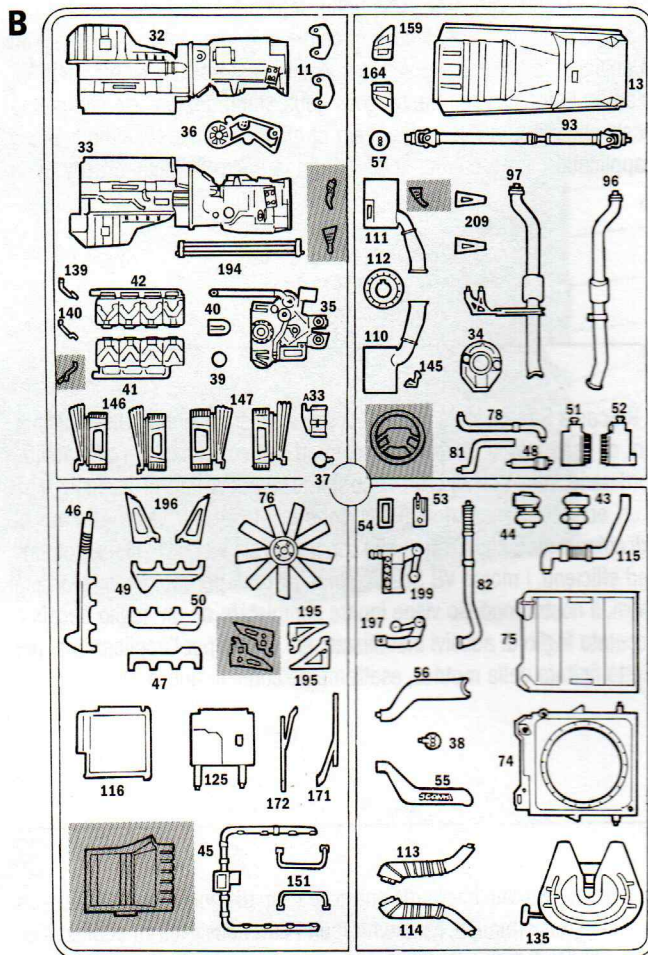
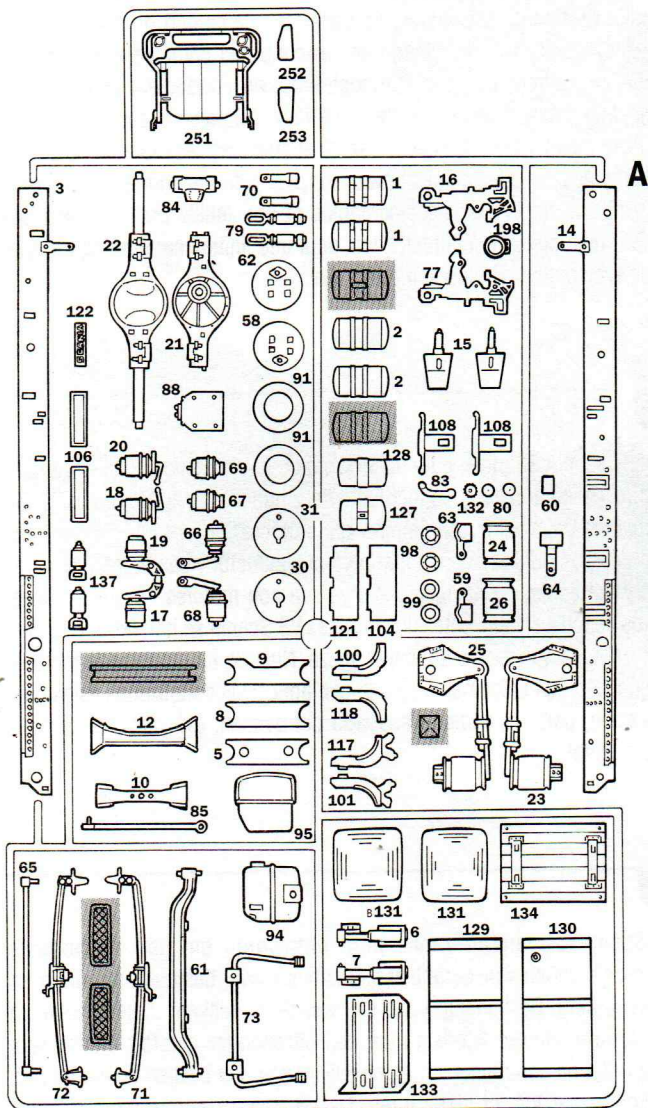

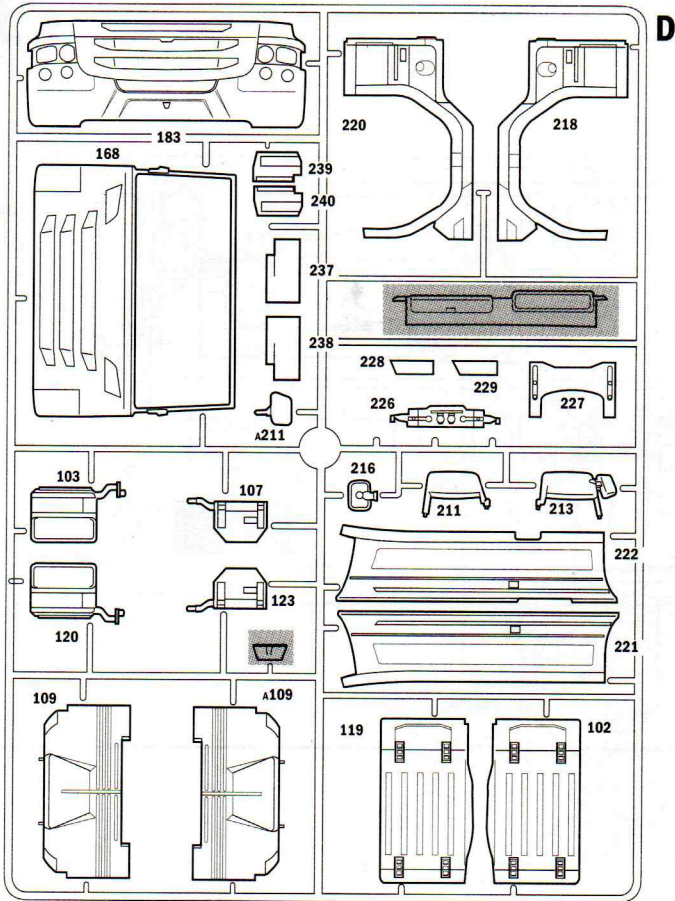

D



CUT
ENTFERNEN
RETRER
SEPARARE



Parts not for use
Telle werden nicht verwendet
Parti da non utilizzare
Pièces à ne pas utiliser



RIBADIRE A CALDO
RIVET HOT
WARM EINNIETEN
RIVER A CHAUD
REFORZAR AL CALOR
VERHIT VASKLINKEN VARMNITA

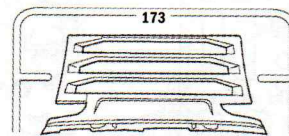

E

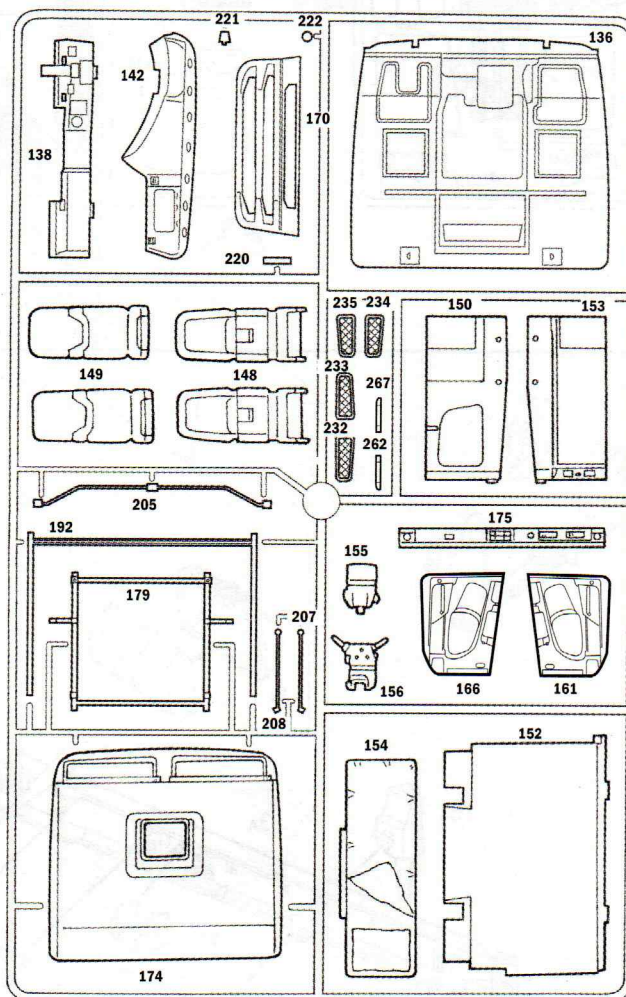

E

G

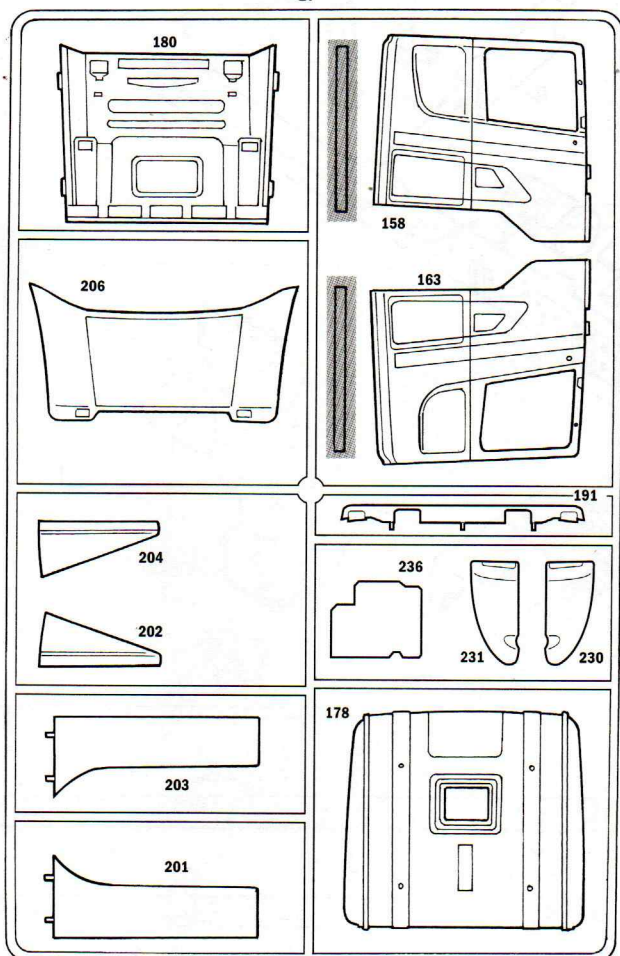

x7

SUGGESTED COLORS

<p>A METAL GLOSS SILVER F.S. 17178 ITALERI ACRYLICPAINT - 4678AP</p>	<p>B GLOSS WHITE F.S. 17875 ITALERI ACRYLICPAINT - 4696AP</p>	<p>C GLOSS RED F.S. 11302 ITALERI ACRYLICPAINT - 4605AP</p>
<p>D GLOSS ORANGE F.S. 12197 ITALERI ACRYLICPAINT - 4682AP</p>	<p>E FLAT GUNSHIP GRAY F.S. 36118 ITALERI ACRYLICPAINT - 4752AP</p>	<p>F FLAT BLACK F.S. 37038 ITALERI ACRYLICPAINT - 4768AP</p>
<p>G FLAT INSIGNA YELLOW F.S. 33538 ITALERI ACRYLICPAINT - 4721AP</p>		

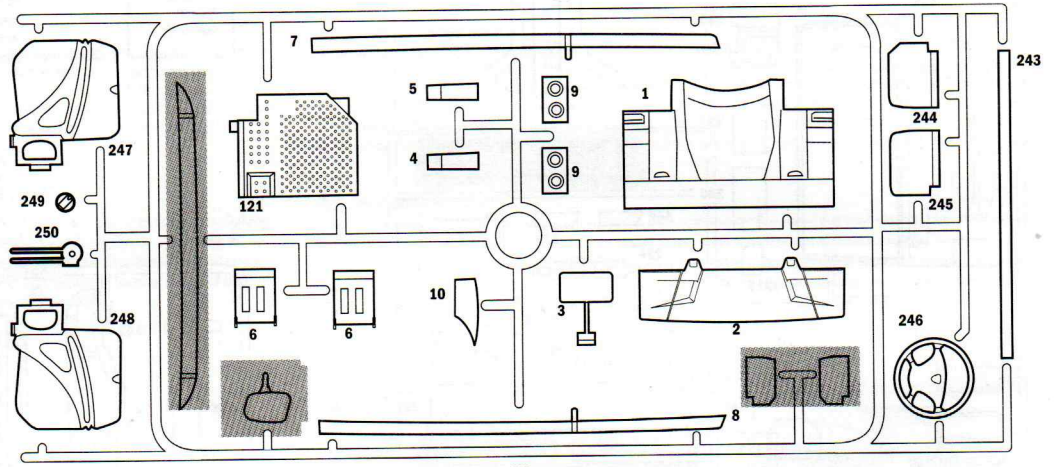
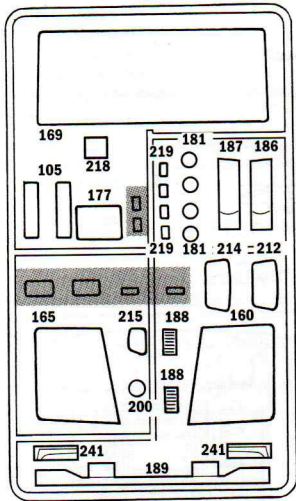

1

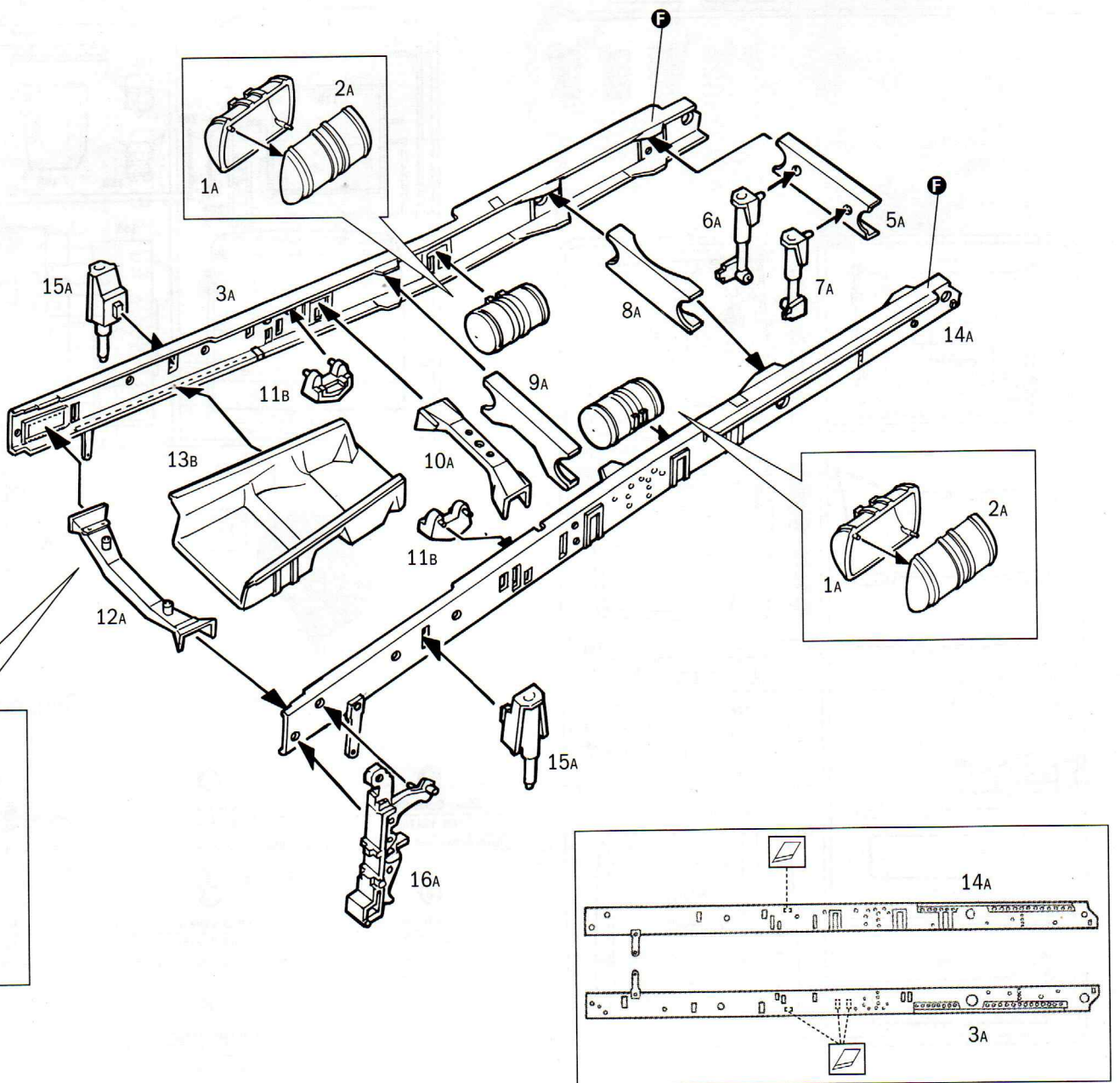

2

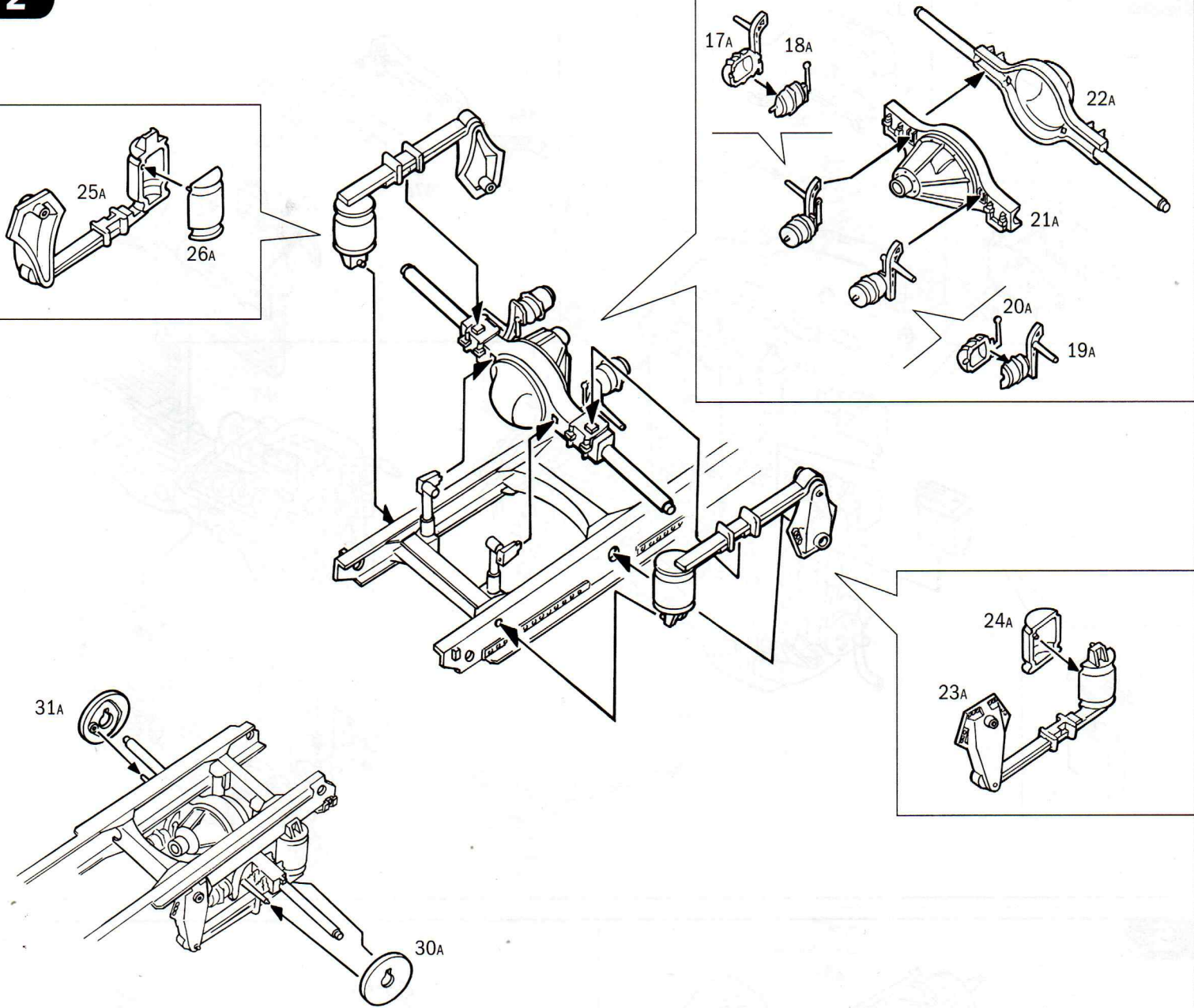

3

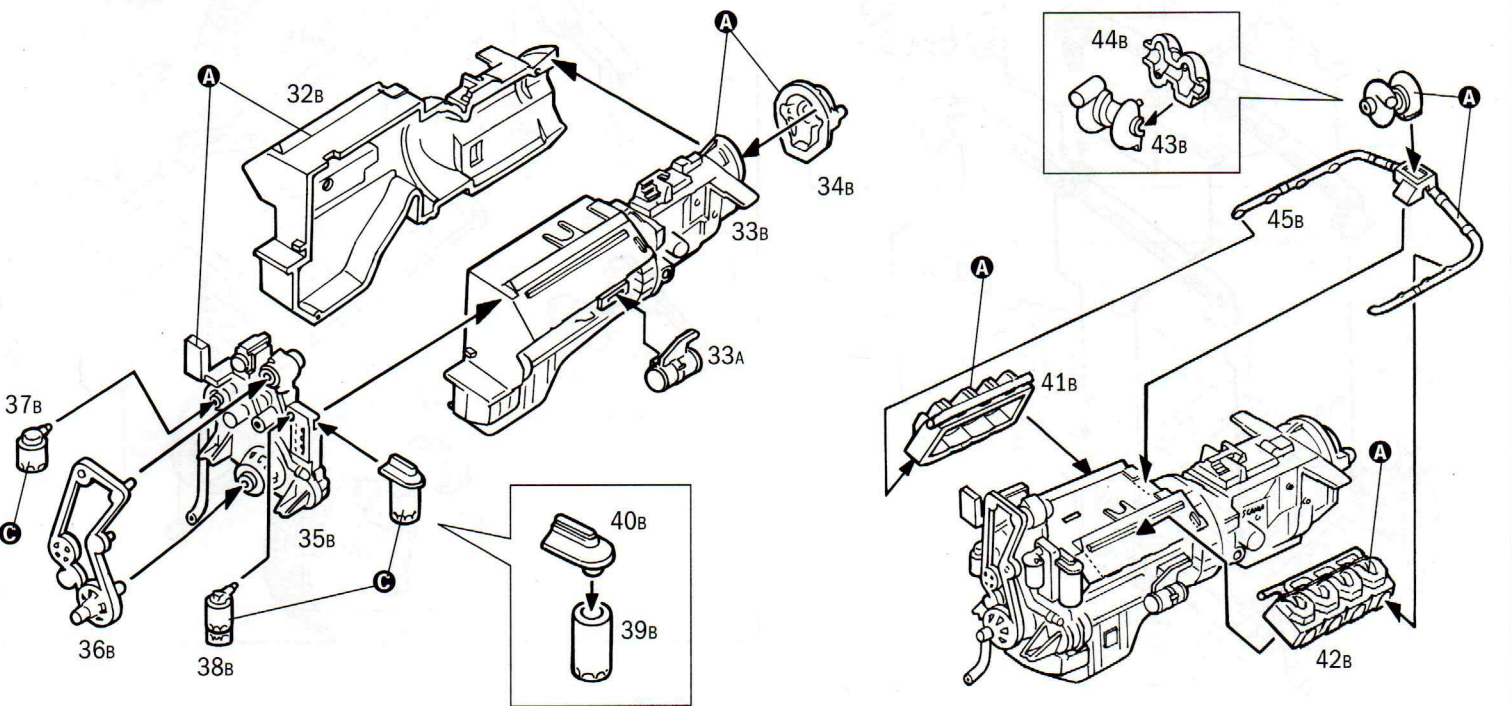

4

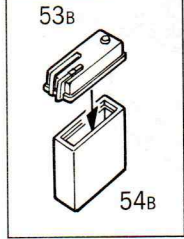
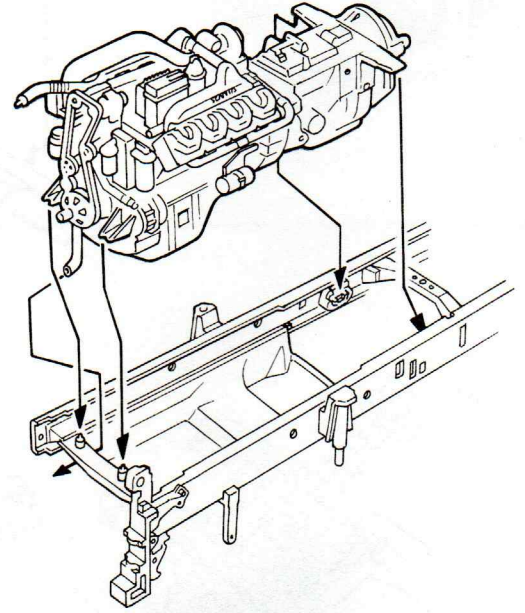
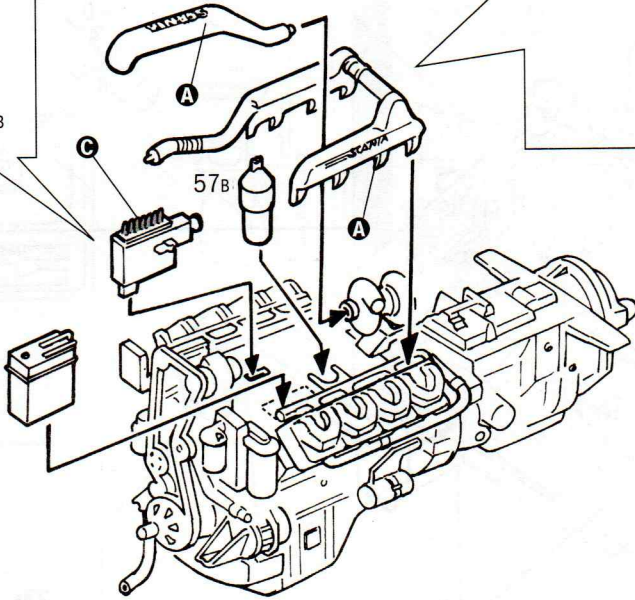
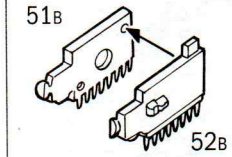
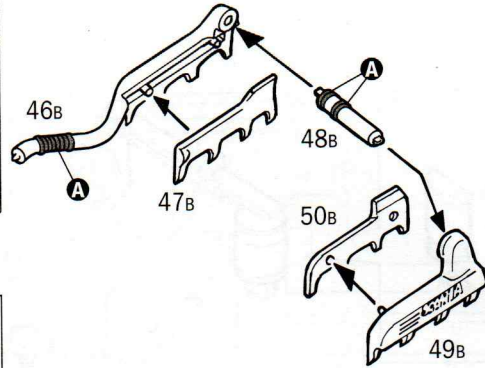
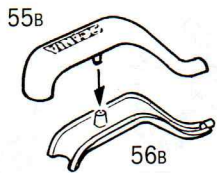

5

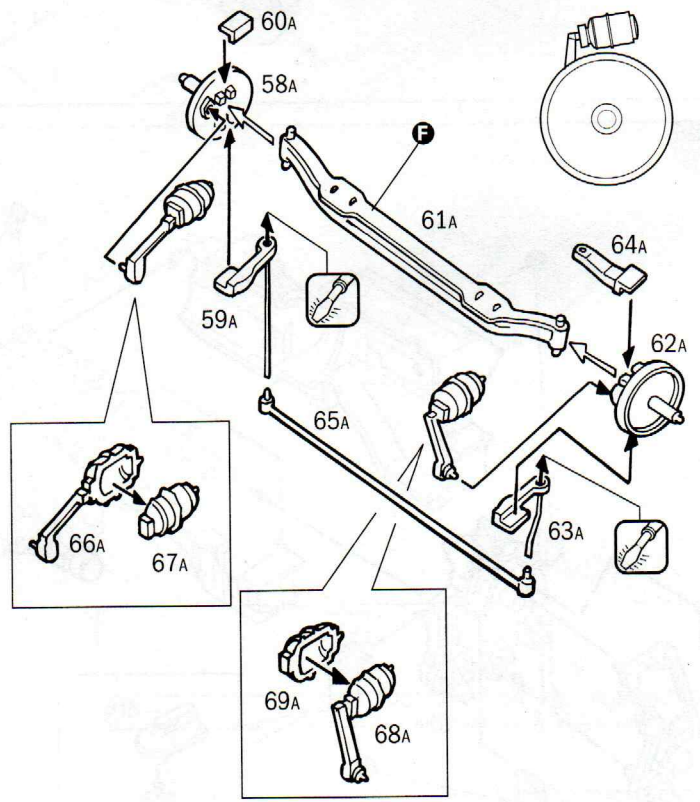
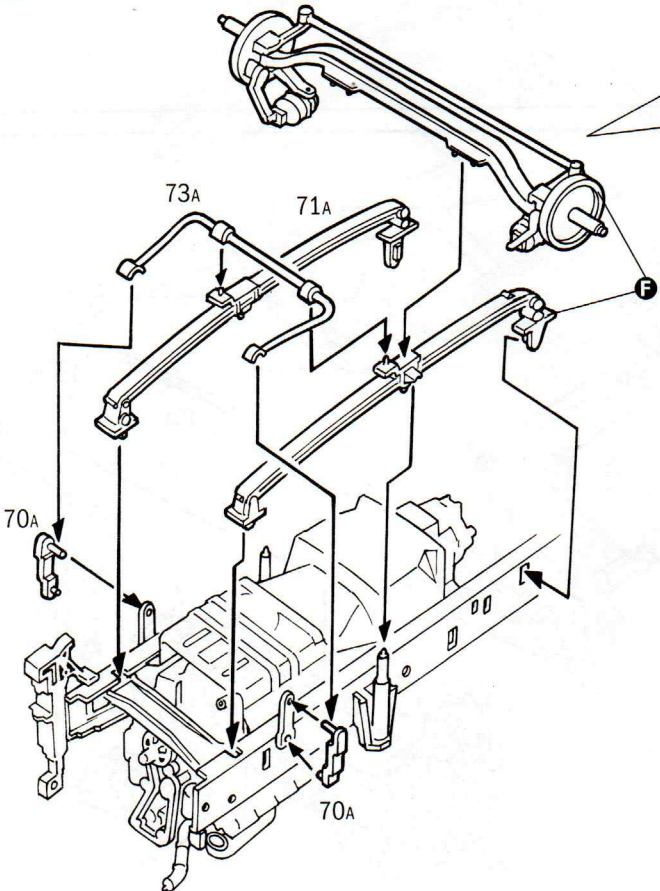

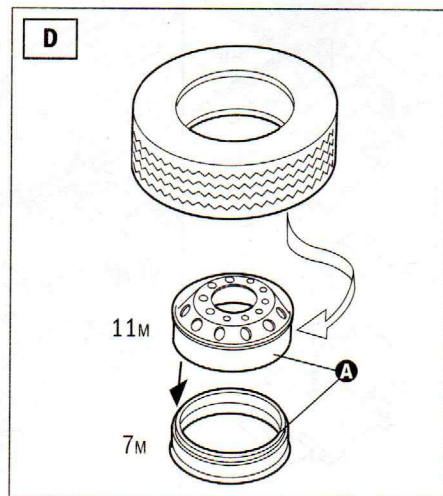
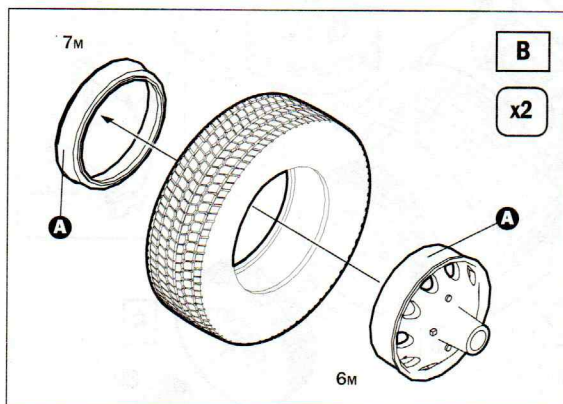
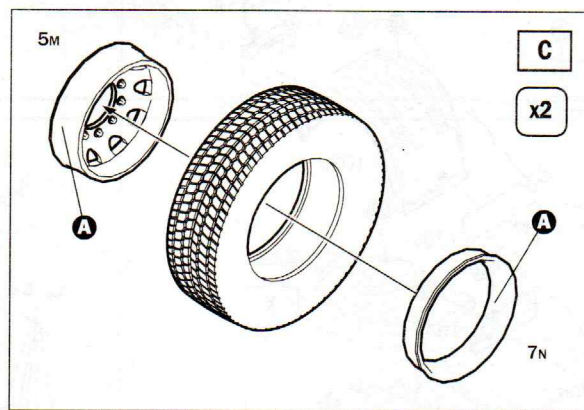
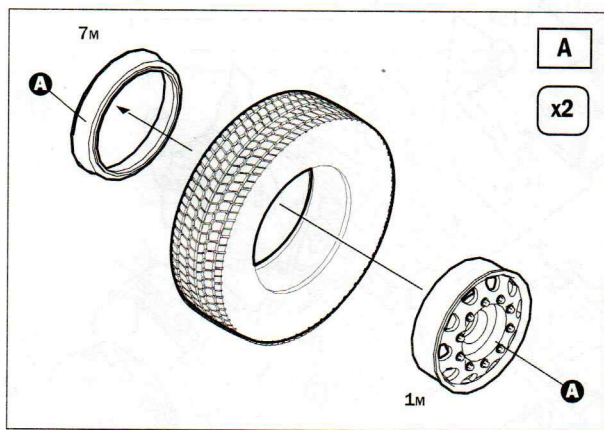
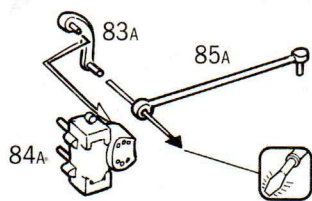
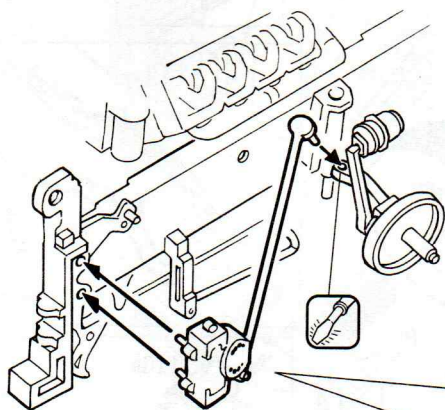
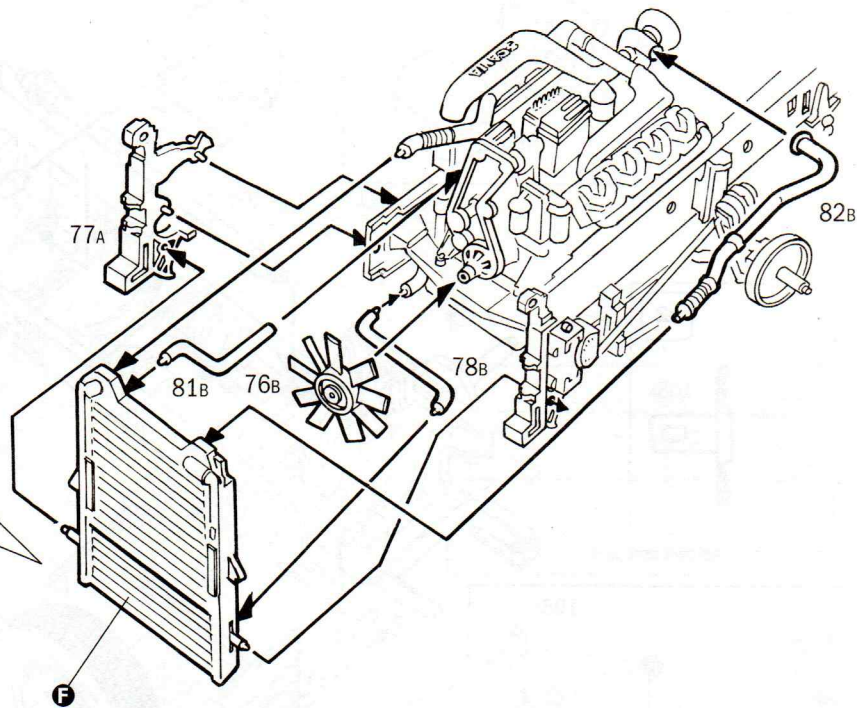
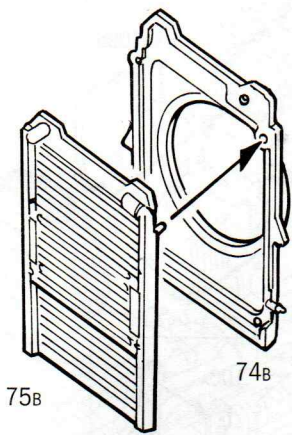

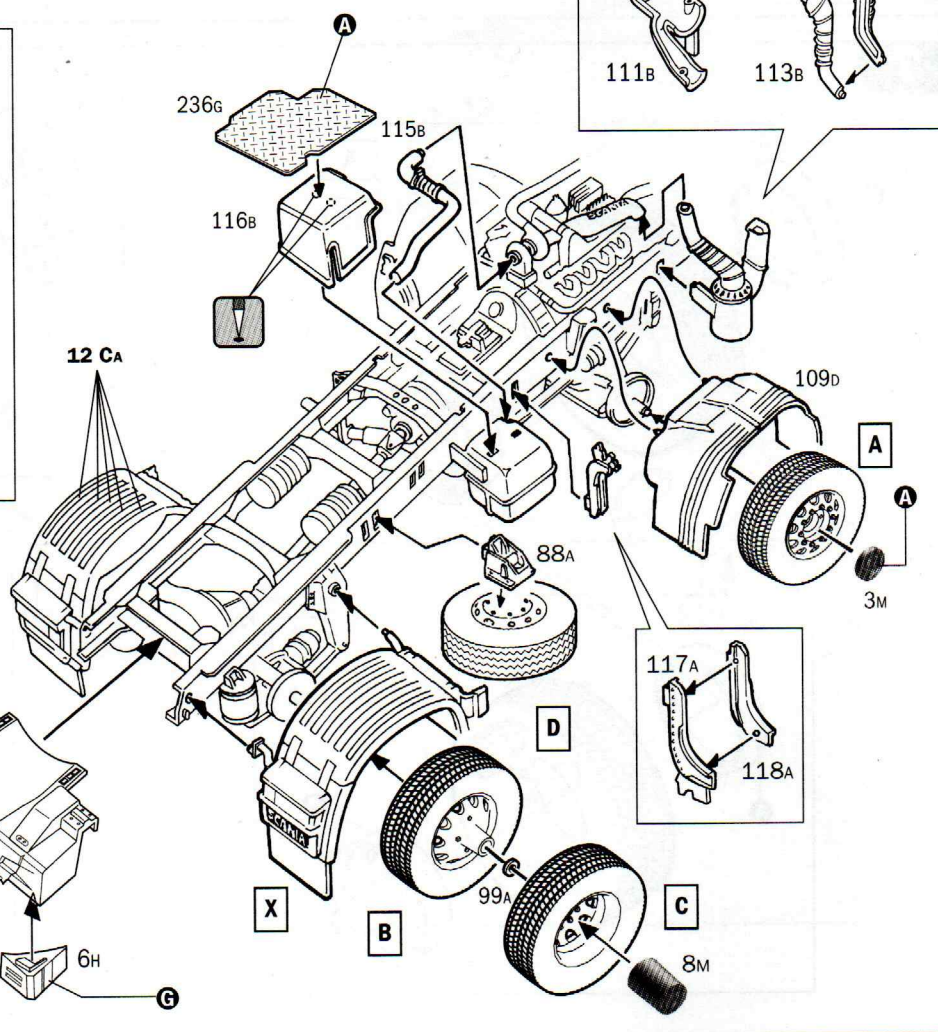
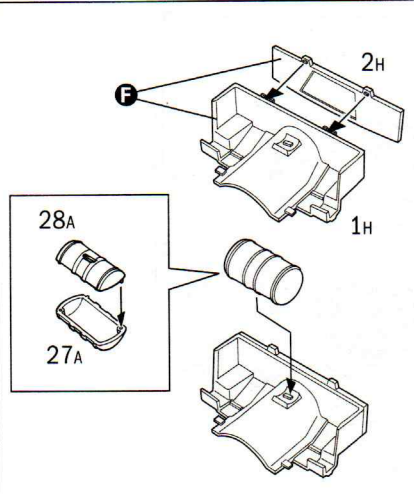
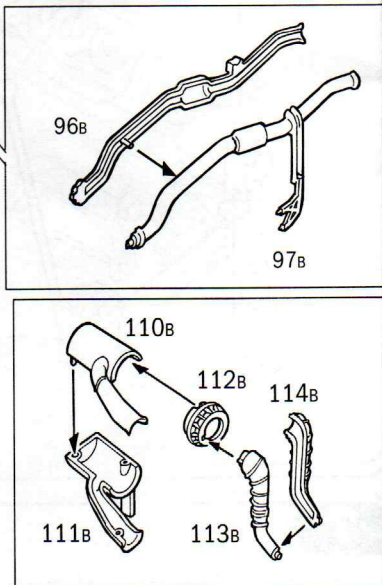
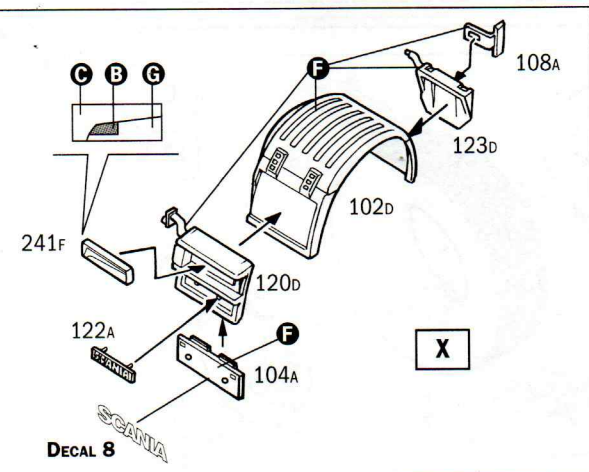
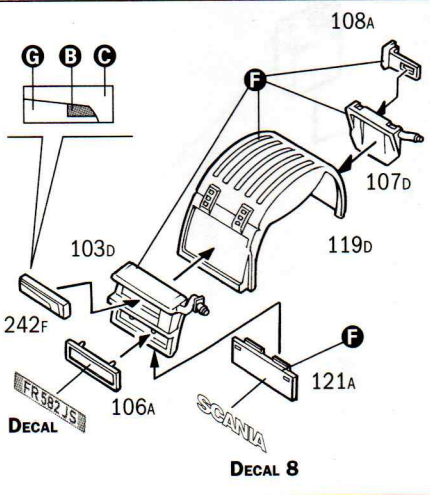
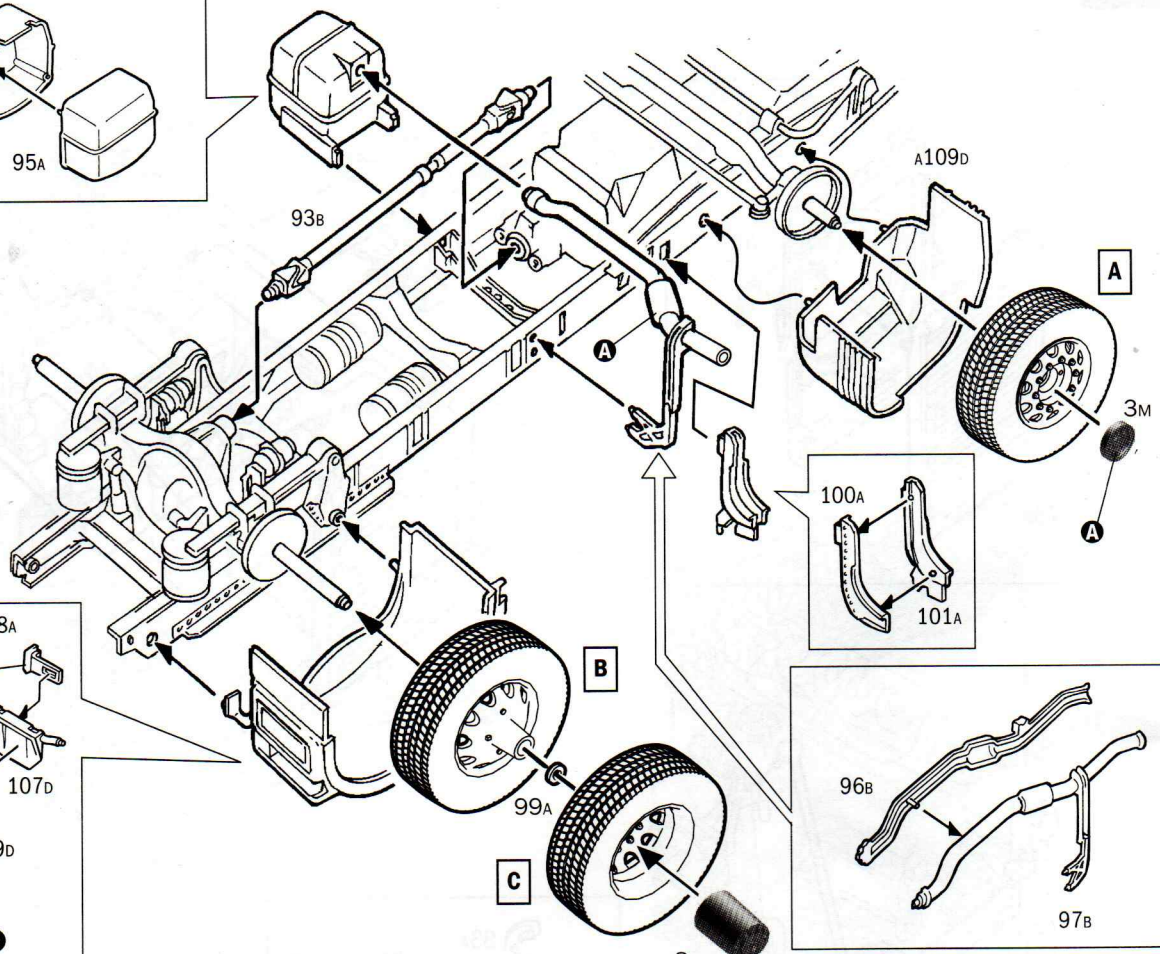
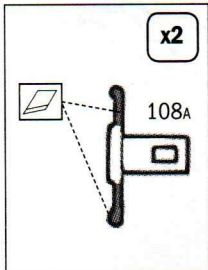
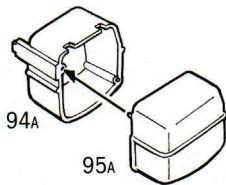

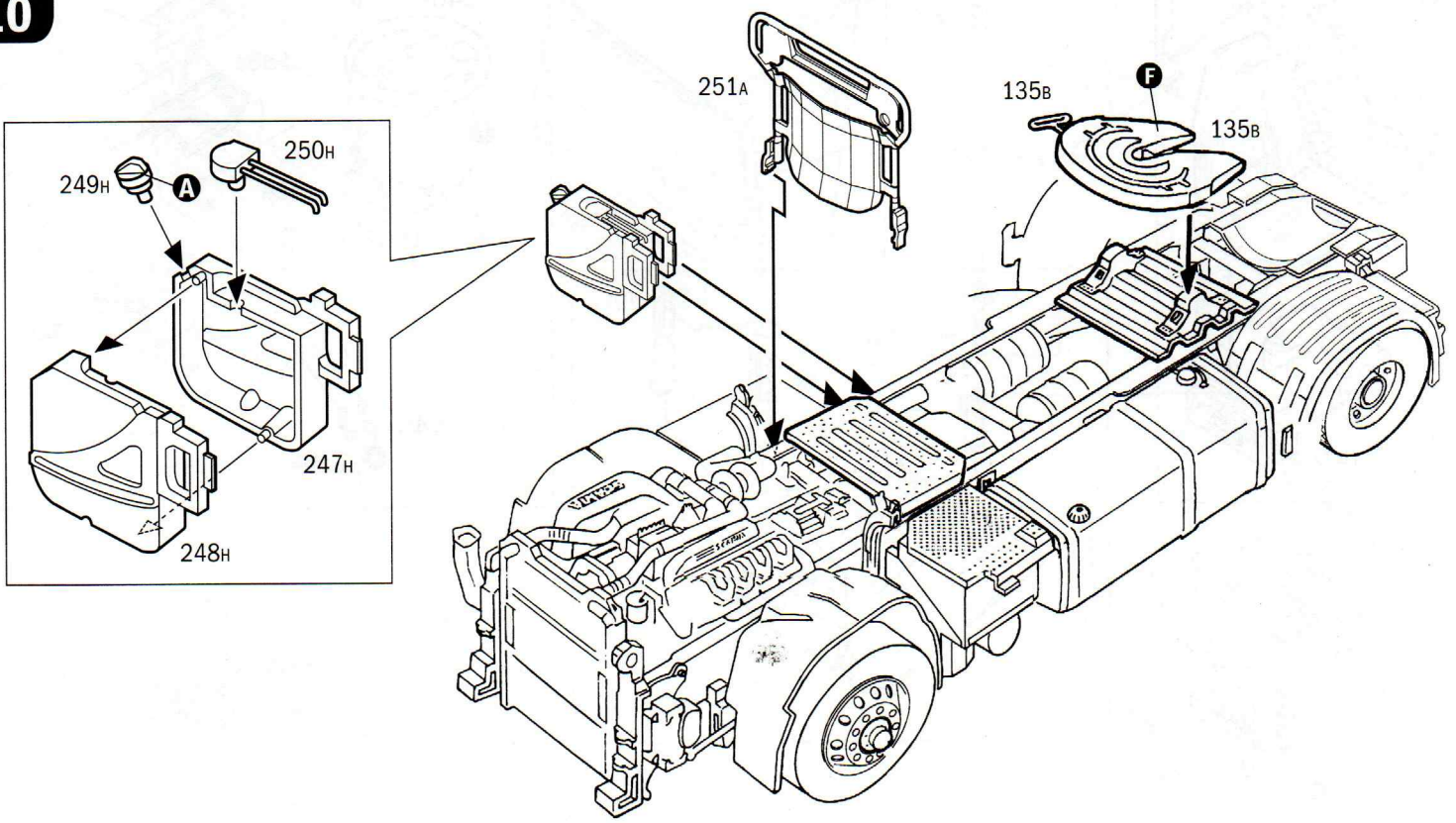
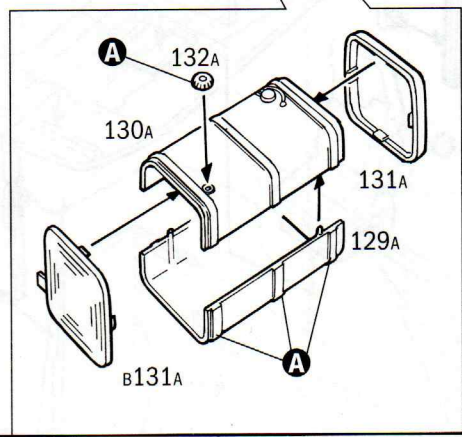
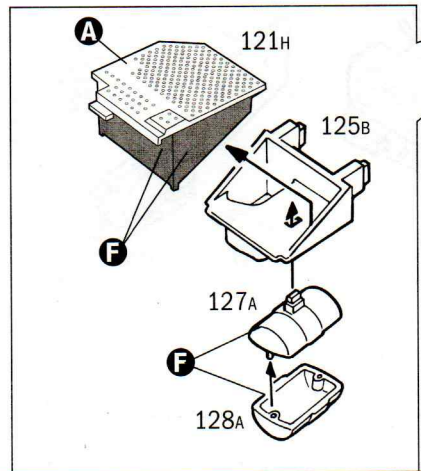
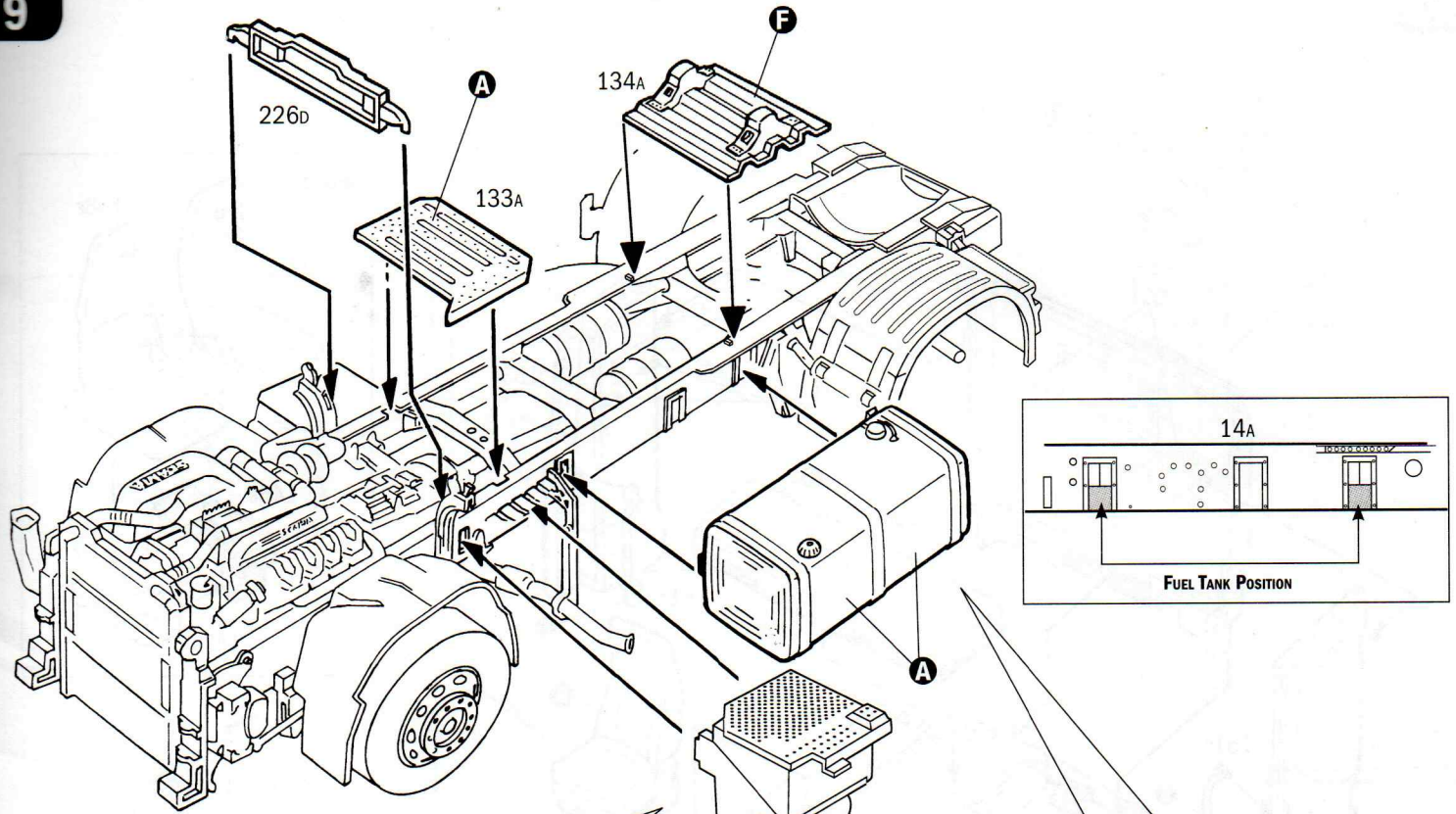

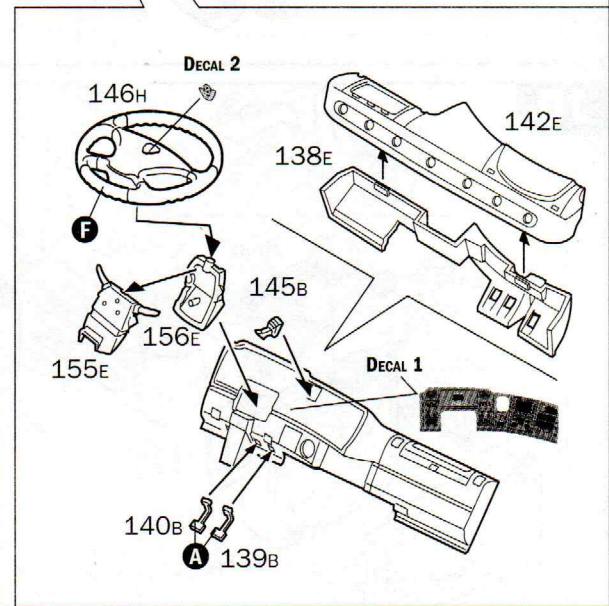
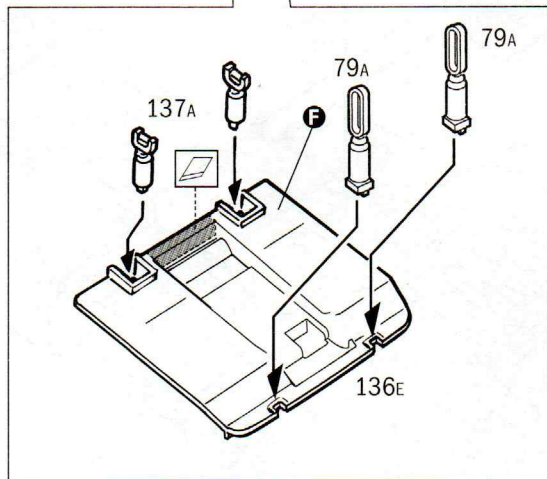
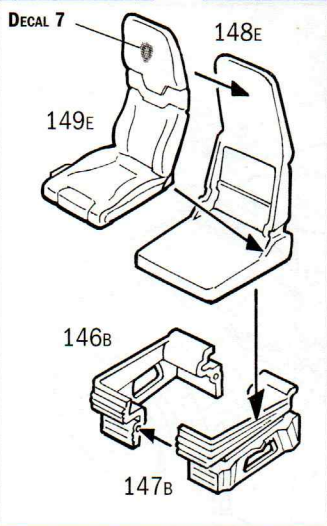
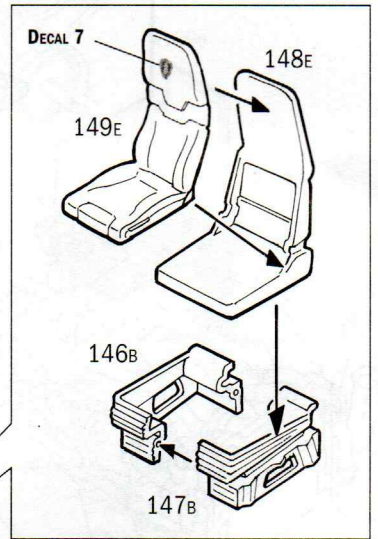
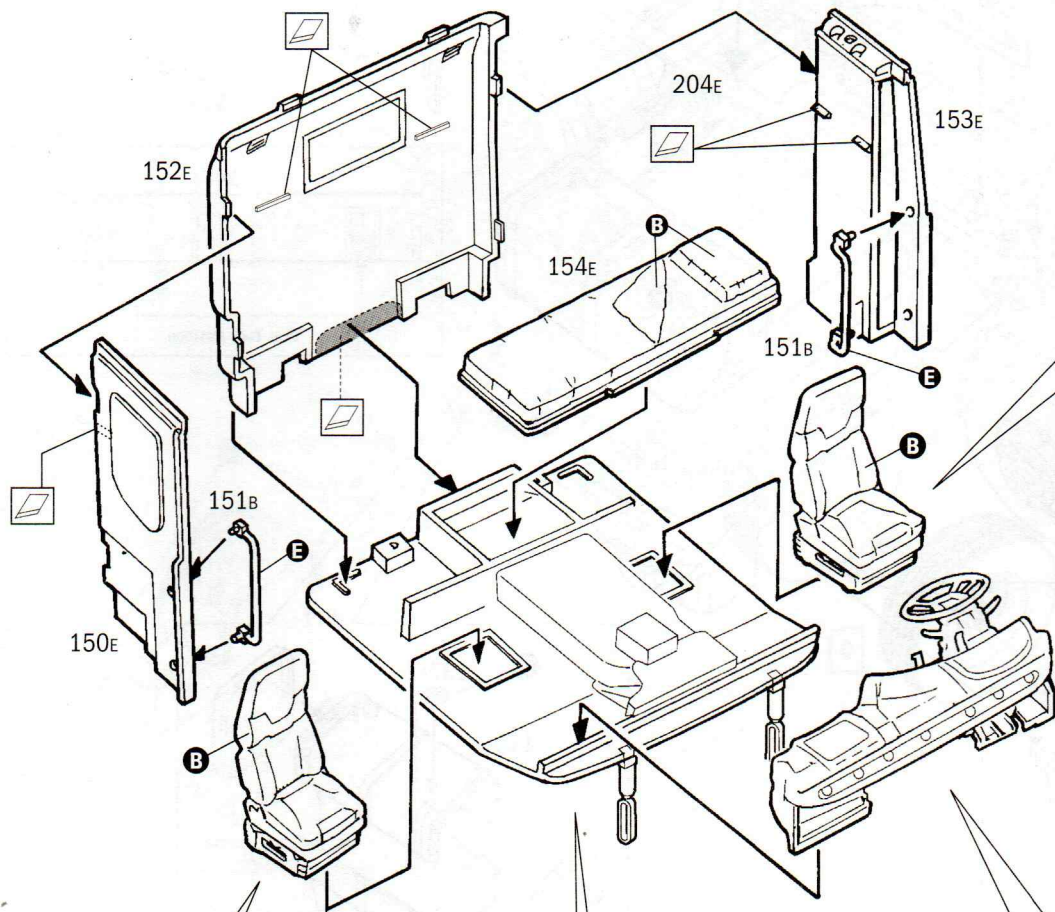

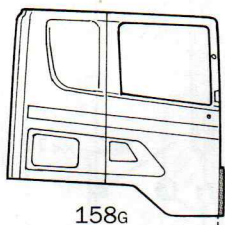

158G

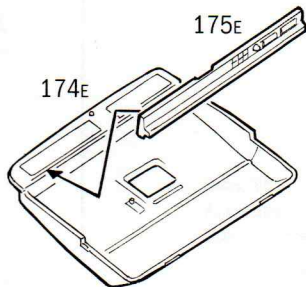

174E

175E

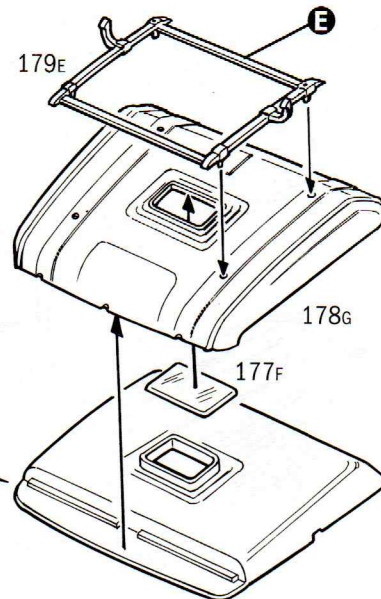

179E

178G

177F

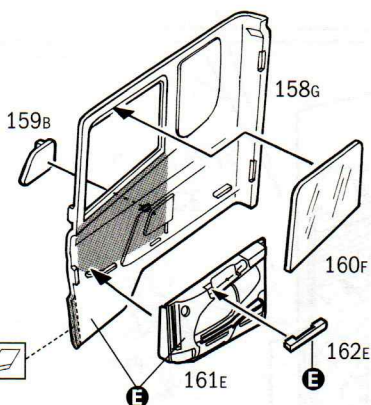

158G

159B

160F

161E

162E

E

E

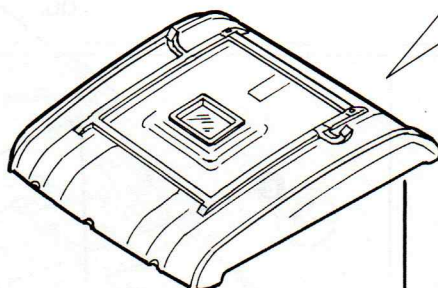

F

180G

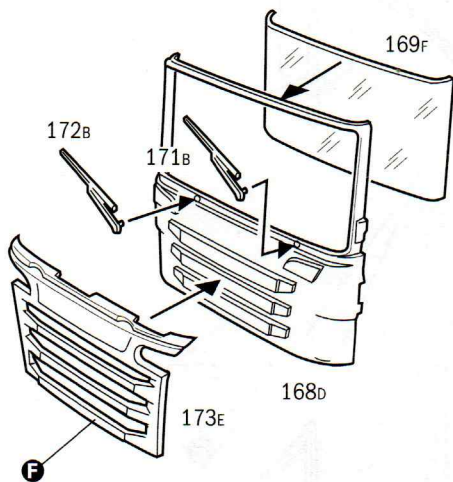
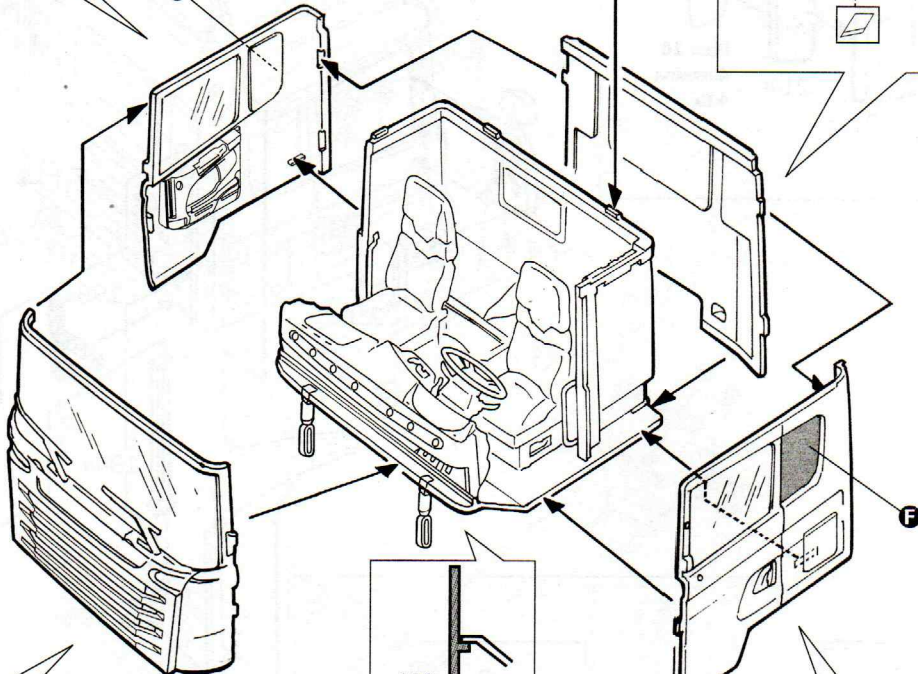
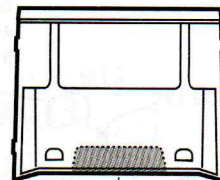

169F

172B

171B

168d

173E

F

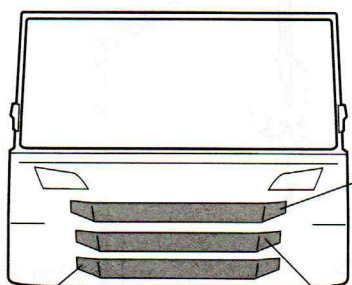

168d

F

F

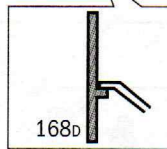

168d

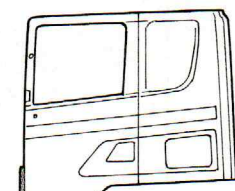

163G

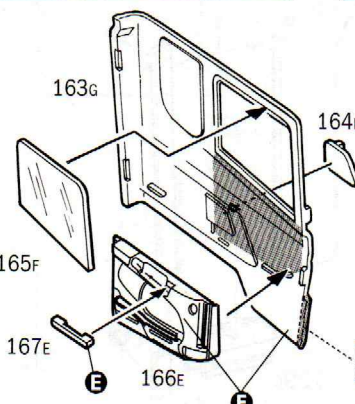

163G

164B

165F

167E

166E

E

E



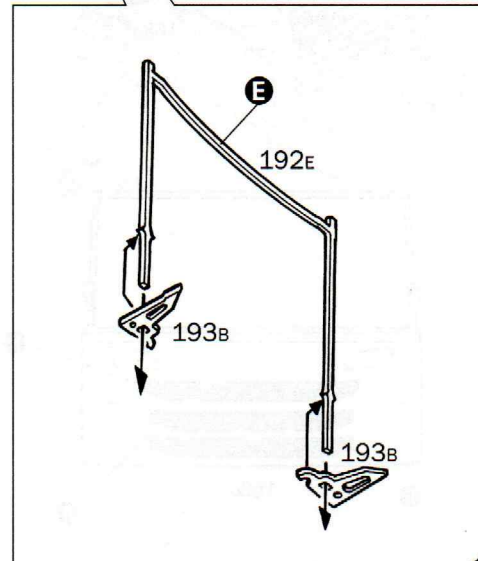
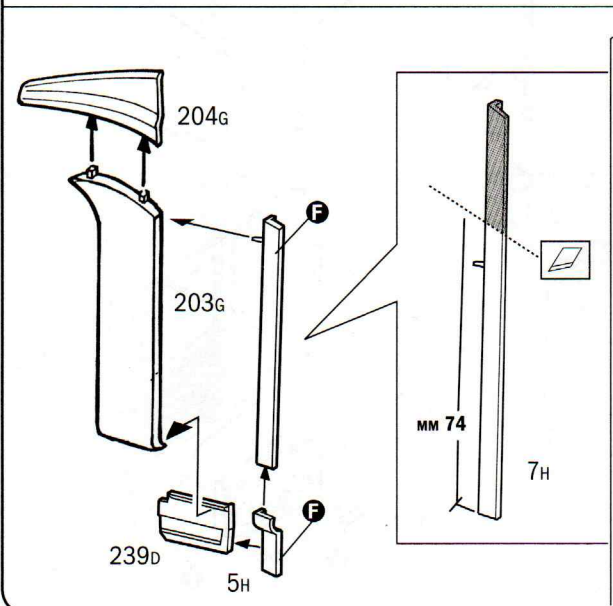
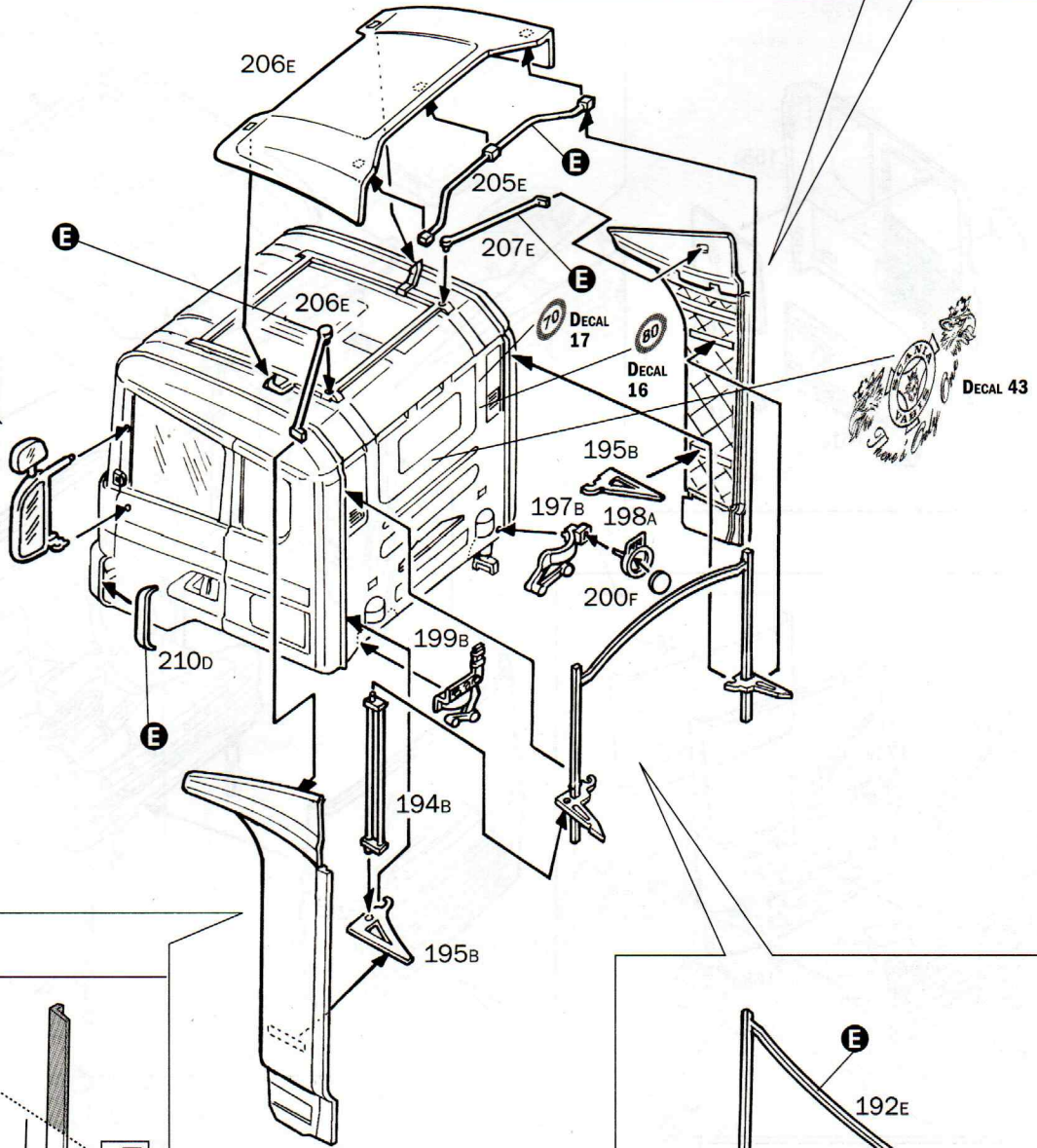
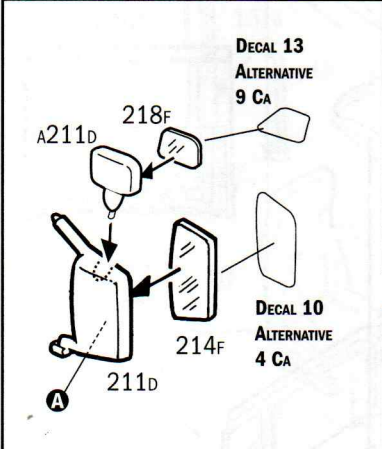
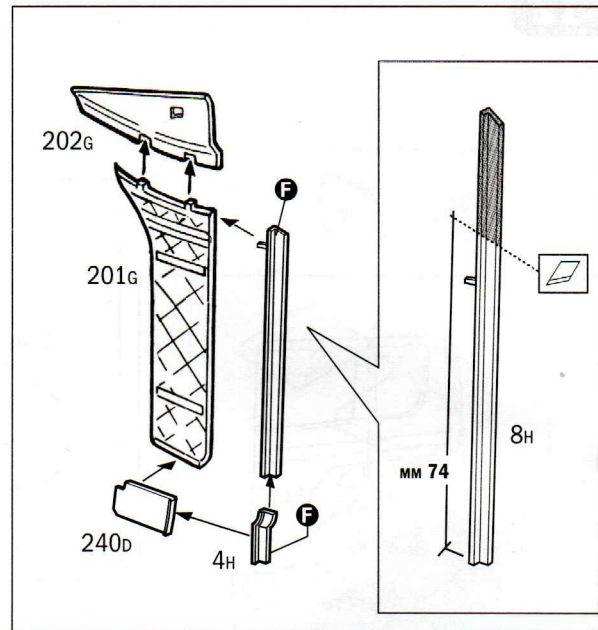

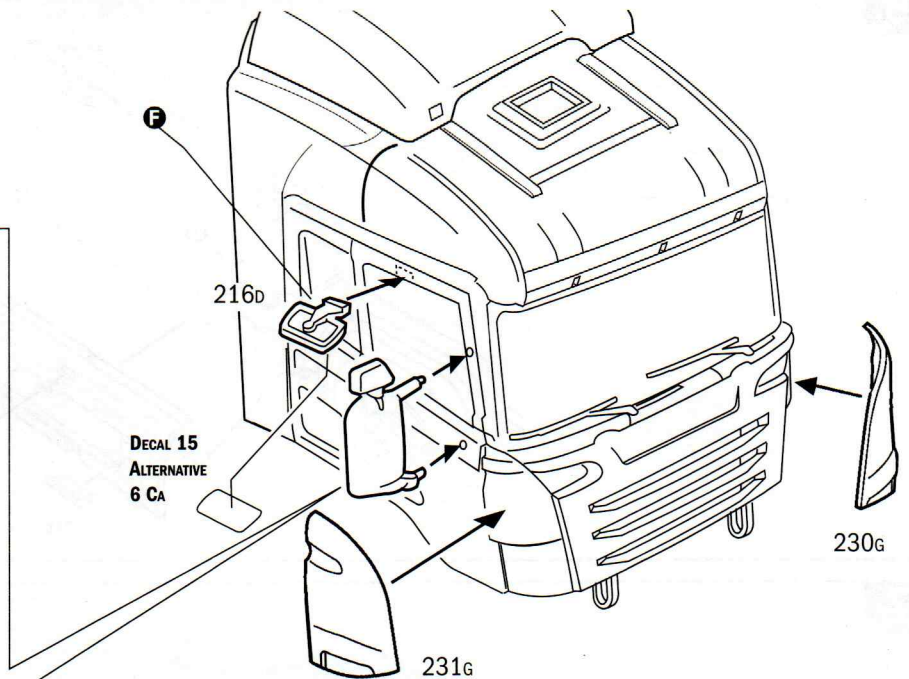
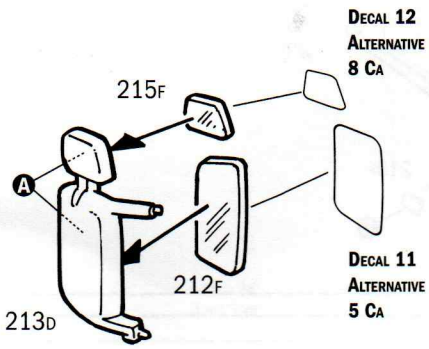

FOLLOWING THIS
SEQUENCE

- A B C

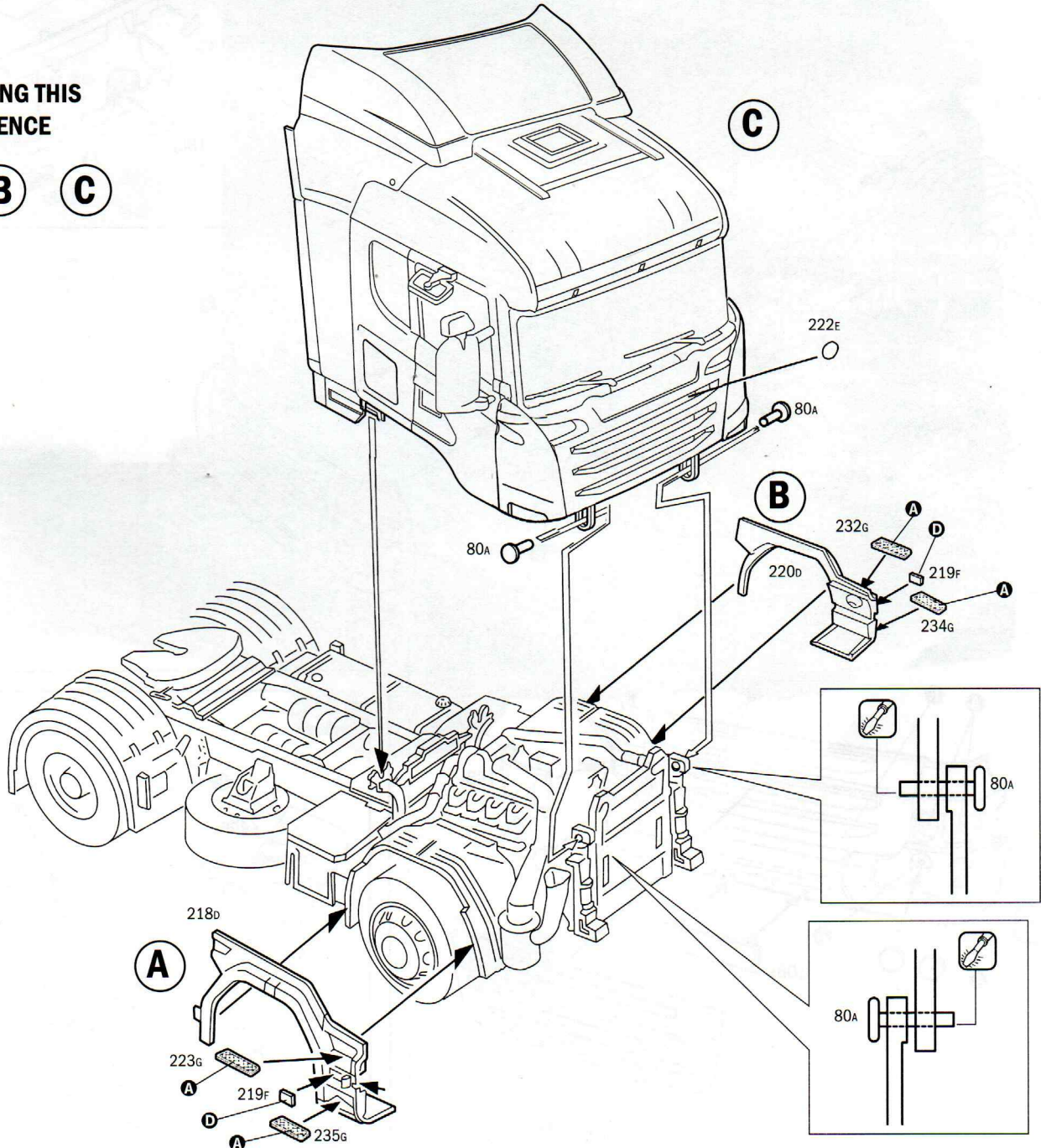

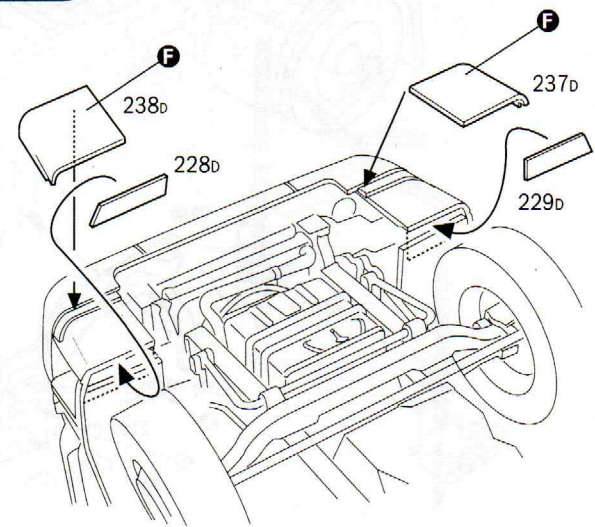
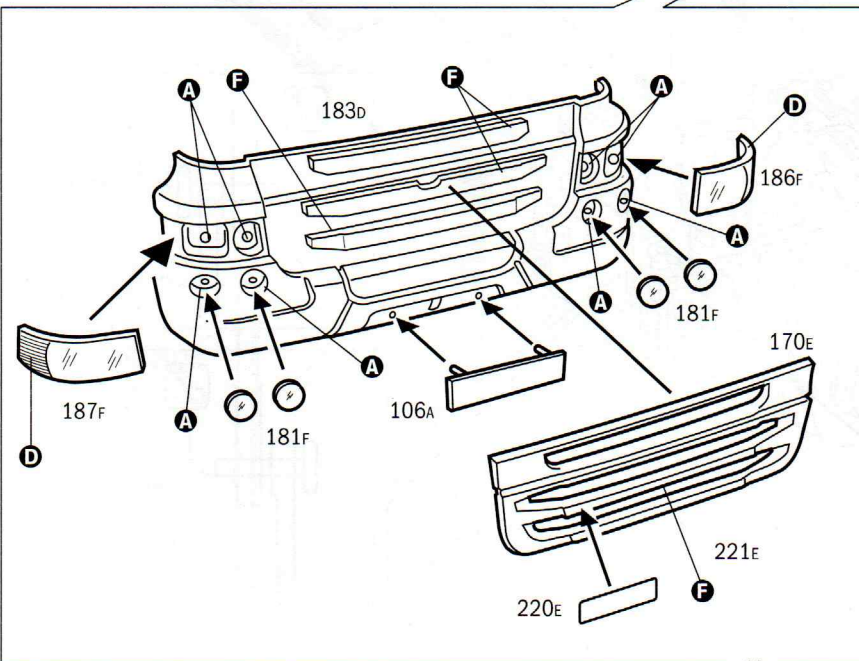
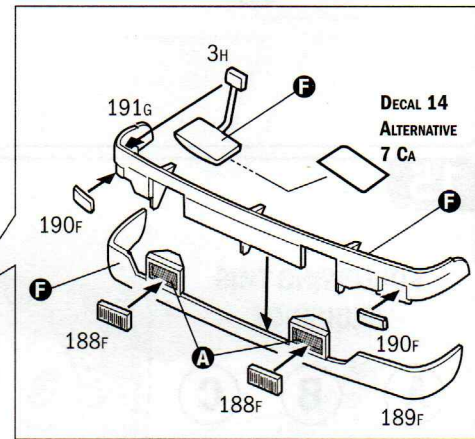
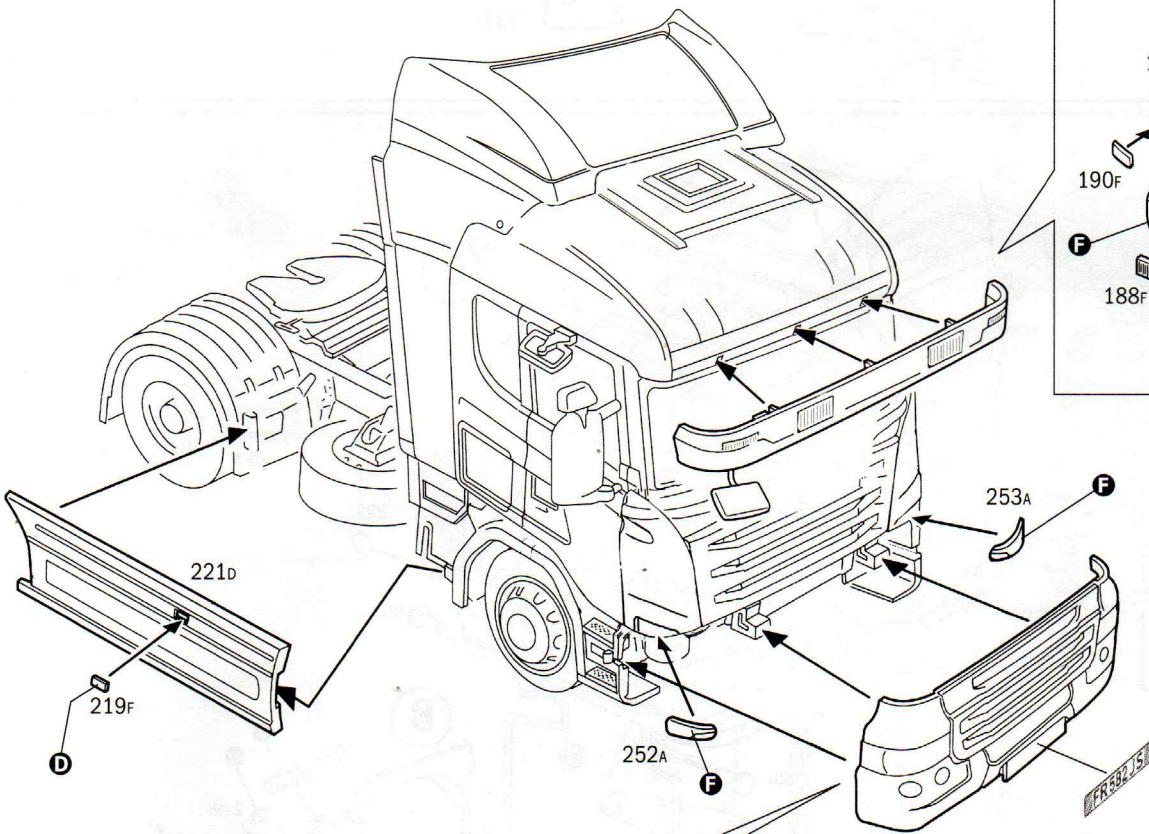
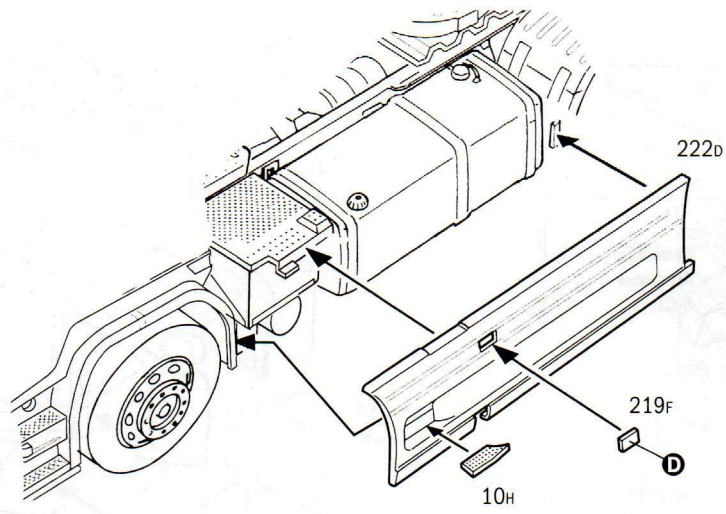

Istruzioni per l'applicazione delle decalcomanie. Ritagliare le decalcomanie occorrenti dal foglio, immergerle in un bicchiere di acqua pulita per circa 20", metterle in posizione sul modello e farle scivolare dalla carta: per una migliore aderenza compprimerle con una pezzuola pulita.

Direction for applying the decals: cut the required decals out of the sheet; dip the into a glass of clean water for about 20"; position the decals on the kit, letting them slide from the paper. For a better adesion, press them by means of a clean rag.

Påsättning av decaler: klipp ut den decal som skall användas och doppa den i ett glas vatten under en 20". Sätt decalen på plats på modellen och lat den sakta glida av pappret. För att den skall sitta ordentligt, tryck till med en torr duk.

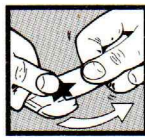

Anweisungen für Abziehbilder-Anbringung: Die benötigten Abziehbilder vom Blatt abscheiden, in ein Glas reines Wasser für etwa 20" eintauchen, auf das Modell legen und dann vom Papierbogen abnehmen. Um eine bessere Haftung zu erzielen, die Abziehbilder mit einem reinen Tuch andrücken.

Instruction pour l'application des décalcomanies. Couper les décalcomanies choisies et les plonger environ 20" dans un peu d'eau propre. Les placer sur le modèle en les faisant glisser de leur feuille et presser avec un morceau de chiffon pur éliminer les bulles d'air.

Istrucciones Para la aplicación de las calcomanías: cortar las requeridas, sumergirlas en un recipiente de agua limpia durante 20", colocar las calcomanías sobre el modelo, haciéndolas deslizar sobre el papel. Para una mejor adherencia, presionarlas con un trapajo limpio.

Transfers: knip het benodigde deel uit, dempel et ca. 20" onder water, oudt het transfer tegen het model en schuif het vanaf het papier op zijn plaats. Met een schoon doekje aandrukken.

デカール使用法: 台紙から、それぞれのマークを切り取ります。ぬるま湯に20秒くらいつけて、引き上げます。マークを必ず水平にして台紙からとり、指定の位置にはめてください。ゆるらかな布でマーク上を押して気泡を取ってください。マーク画には、かわくまで手をふれないでください。

Указания по применению декалей: Отрежьте нужную вам часть декали от общего листа, поместите ее на 20 минут в чистую воду, затем, выбрав необходимое место на модели, переведите туда изображение, сдвинув его с бумажной основы. Для лучшего прилипания промакните декаль чистой тряпочкой.

VERSION A

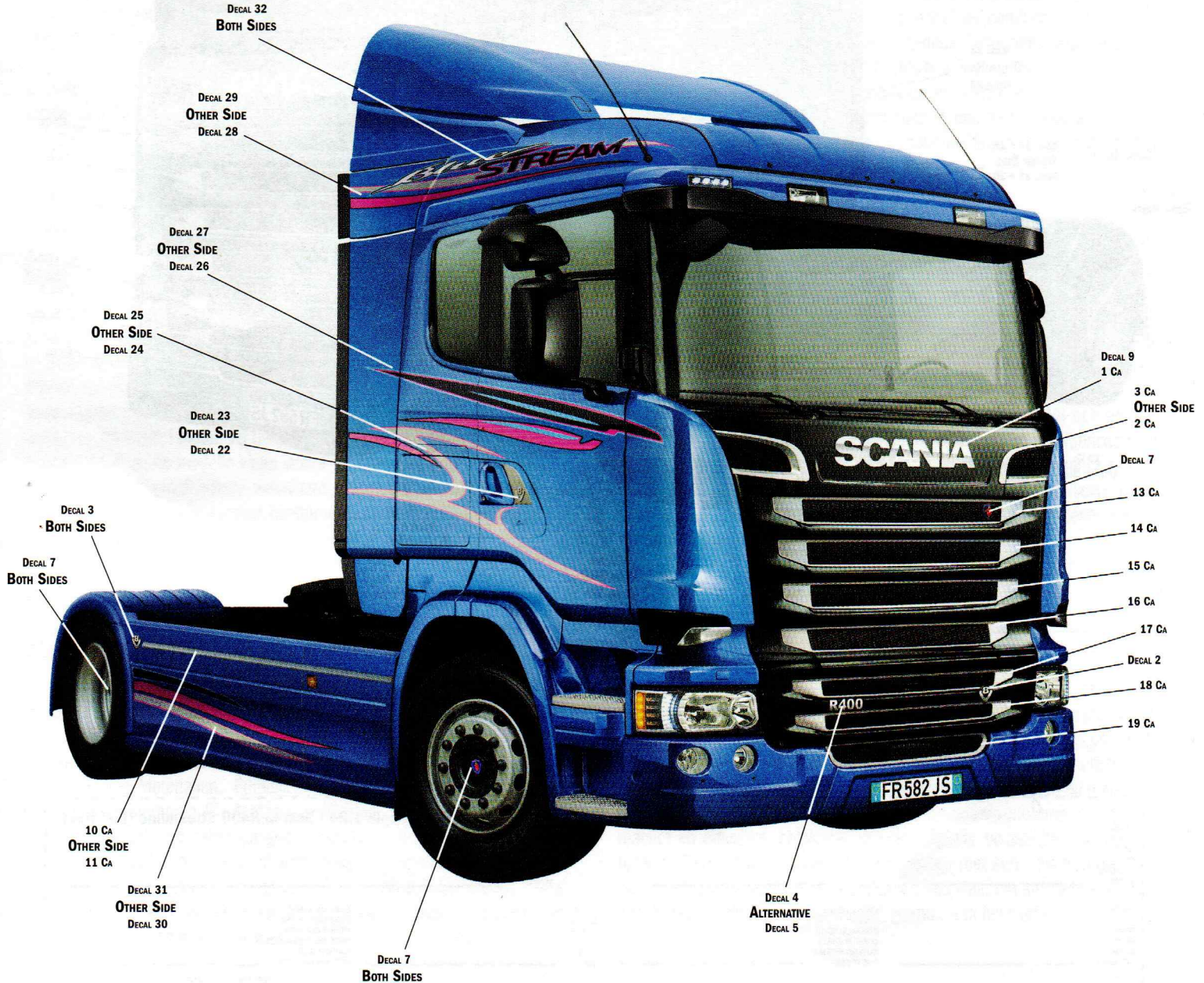

GLOSS FRENCH BLUE
FS. 15180
ITALERI ACRYLICPAINT - 4659AP

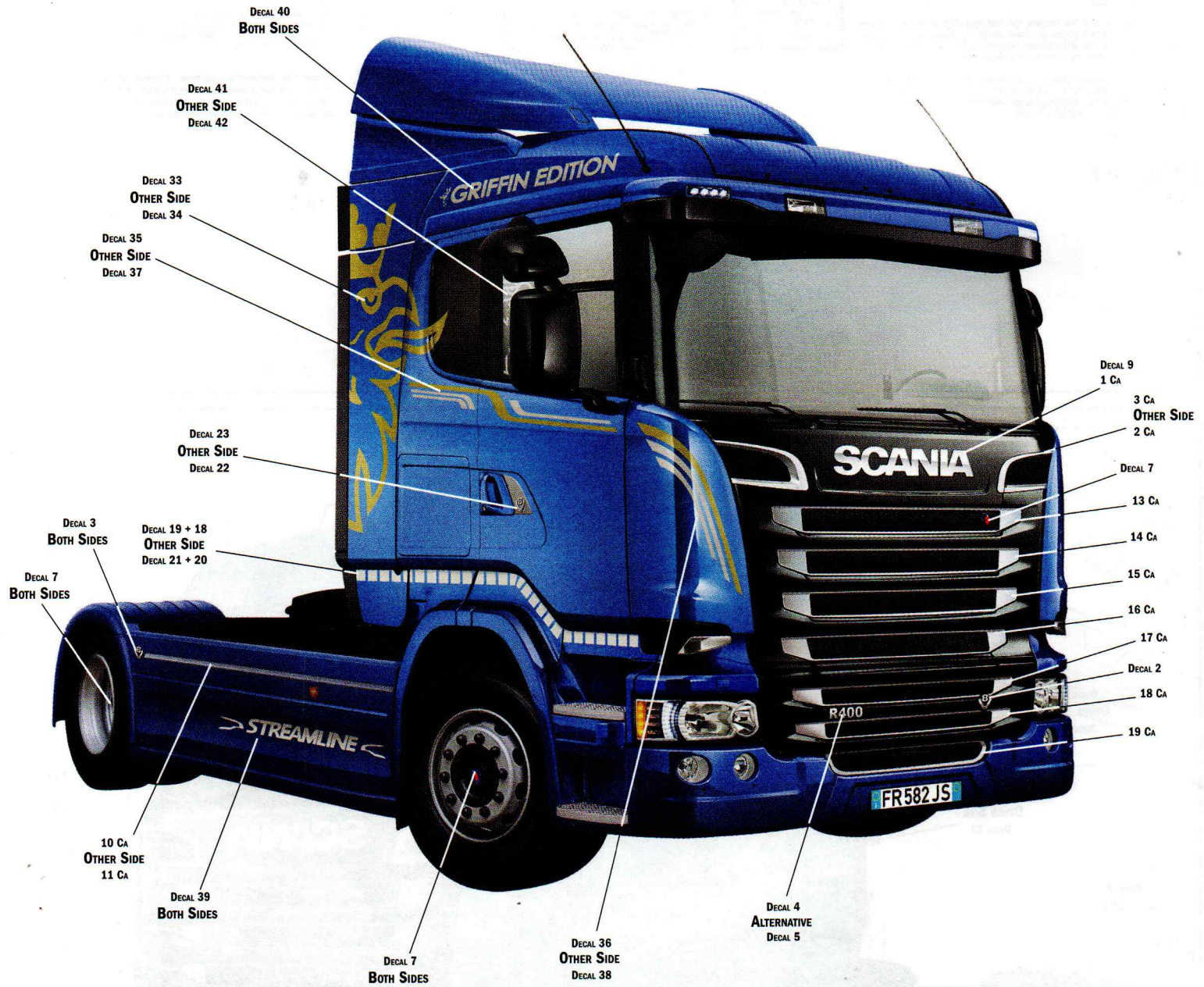

GLOSS FRENCH BLUE
FS. 15180
ITALERI ACRYLICPAINT - 4659AP



KIT No 3947 Scale 1:24 - Scania R400 Streamline (Flat Roof)

NAME / NOME / NAME / NOM / NOMBRE / NAAM _____
 ADDRESS / INDIRIZZO / ADRESSE / ADRESSE / DIRECCION / ADRES _____

TOWN / CITTA' / STADT / VILLE / CIUDAD / GEMEENTE _____
 POSTAL CODE / C.A.P. / POSTALEITZAHN / CODE POSTALE / CODIGO POSTAL / POSTCODE _____
 COUNTRY / NAZIONE / LAND / PAYS / PAIS / LAND _____
 DATE OF BIRTH / DATA DI NASCITA / GEBURTSDATUM / DATE DE NAISSANCE / NACIDO/A EL / GEBORRTEDATUM _____

E-MAIL

DEFECTIVE PARTS / PARTI DIFETTOSE / DEFENTE TEILE / PIECES DEFECTUEUSES / PIEZAS DEFECTUOSAS / DEFECTE ONDERDELEN

PLACE OF PURCHASE / ACQUISTATO PRESSO / ORT DES KAUFES / LIEU D'ACHAT / LUGAR DE COMPRA / PLAATS VAN AANKOOP

Retail Store / Negozio / Einzelhandel / Detailliant / Detaillhandel

Hyper Market / Grande Magazzino / Andere / Grande Surface / Gran Almacén / Hypermarket

ITALERI S.p.A.
Via Pradazzo, 6/B
40012 - Calderara di Reno (BO) ITALY
fax: 0039 51 726 459
e-mail: italeri@italeri.com
www.italeri.com