

PLASTIC MODEL

AZ 7257 AZ 7258 AZ 7259

SCALE : 1/72

The first production Hurricane I flew at Brooklands on 12th October 1937 fitted with an early example of the Rolls Royce Merlin II that was rated at 1,030 hp at 16,250 feet (4,955 m). This power unit drove a fixed pitch two bladed propeller and at a weight of 5,459 lb (2,476 kg), the aircraft attained a maximum speed of 318 mph (512 kph) at 17,400 feet (5,305 m).

In January 1939, the Merlin II gave way to the Merlin III with the fitting of a constant speed three bladed propeller and it was this amended specification that was adopted and all Hurricane Mark I's were constructed using this configuration. Other alterations being the armament, which was four Browning .303 machine guns mounted in the wings.

By the 27th September 1939, Hawker had delivered 497 Hurricanes to the RAF against the initial order of 3,500 and was enough to equip 18 Fighter Command squadrons. But despite the need to bring Britain's fighter strength to its potential, quite a number of Hurricanes were exported to other countries. Fifteen went to Turkey, another 15 went to Finland, and 12 went to Romania while 1 went to Poland.

During 1939 and 1940, 24 Hurricane Mark I's were delivered to Yugoslavia, and Belgium was also granted a licence to build the fighter, although 20 had been acquired from Britain only 15 of these had been delivered.

Plastic parts

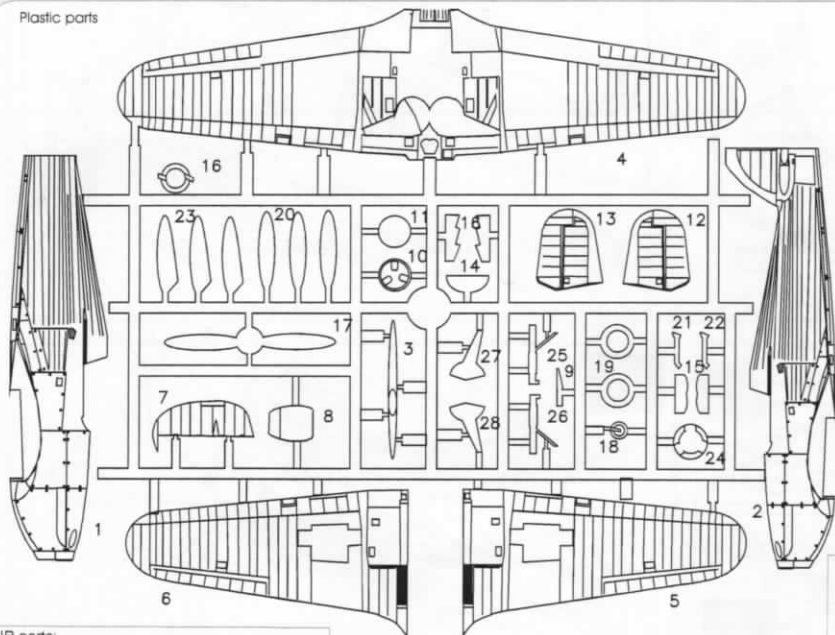

Transparent part



PUR parts:

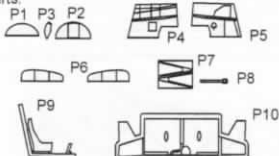

Decals

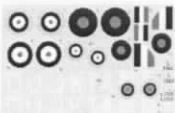

AZ 7257



AZ 7258



AZ 7259



OPTIONAL

VOLBA



BEND

OHNOUT



OPEN HOLE

VYVRTAT OTVOR



SYMMETRICAL ASSEMBLY

SYMETRICKÁ MONTÁŽ



A NOTH

ŽÁREZ



REMOVE

ODRÍZNOUT

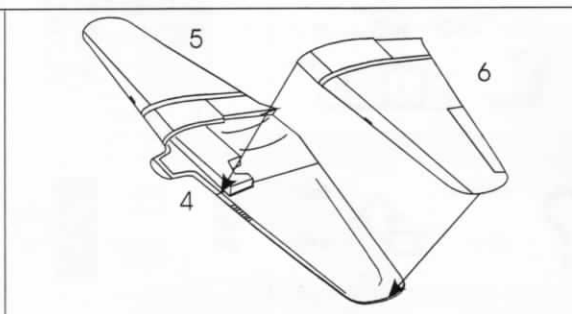
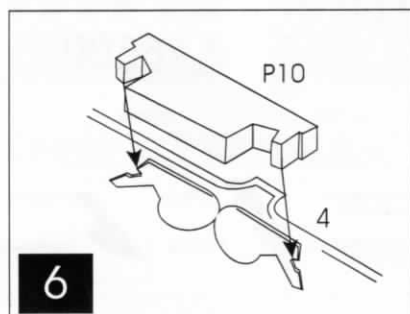
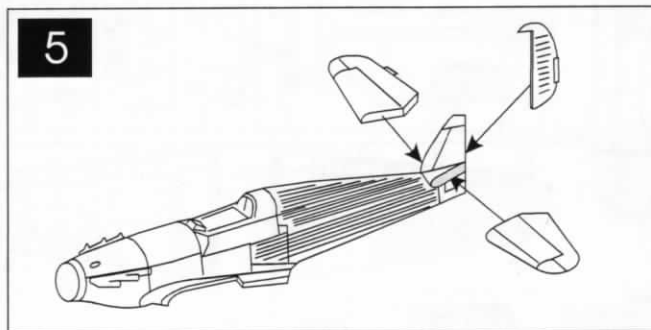
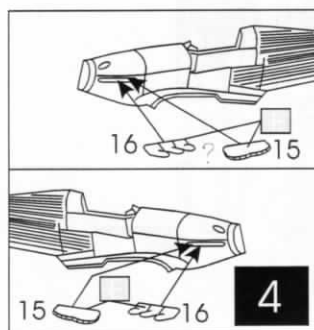
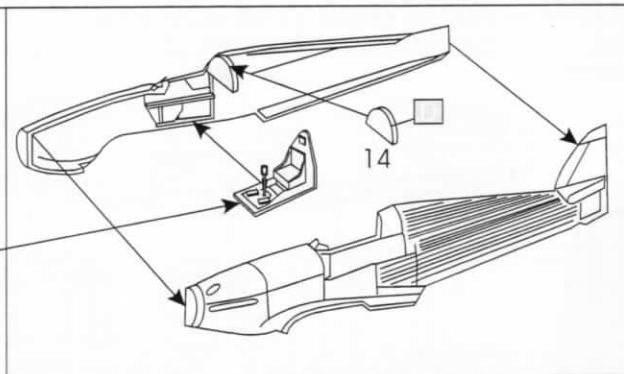
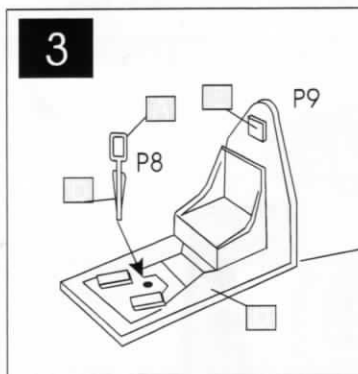
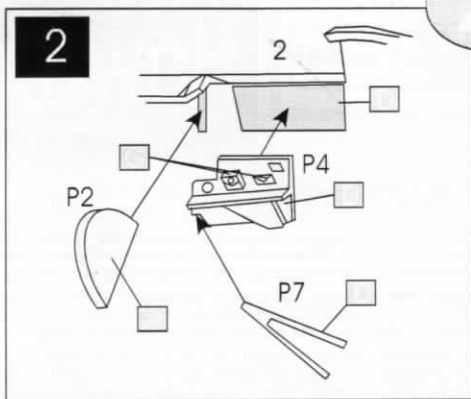
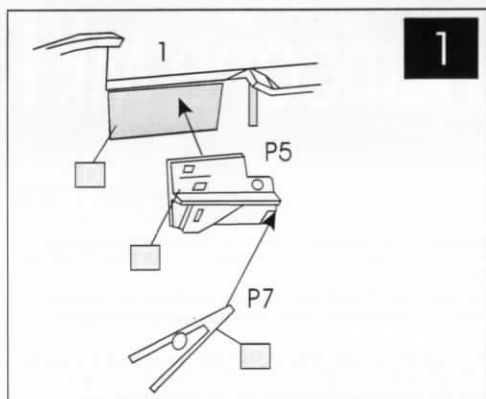

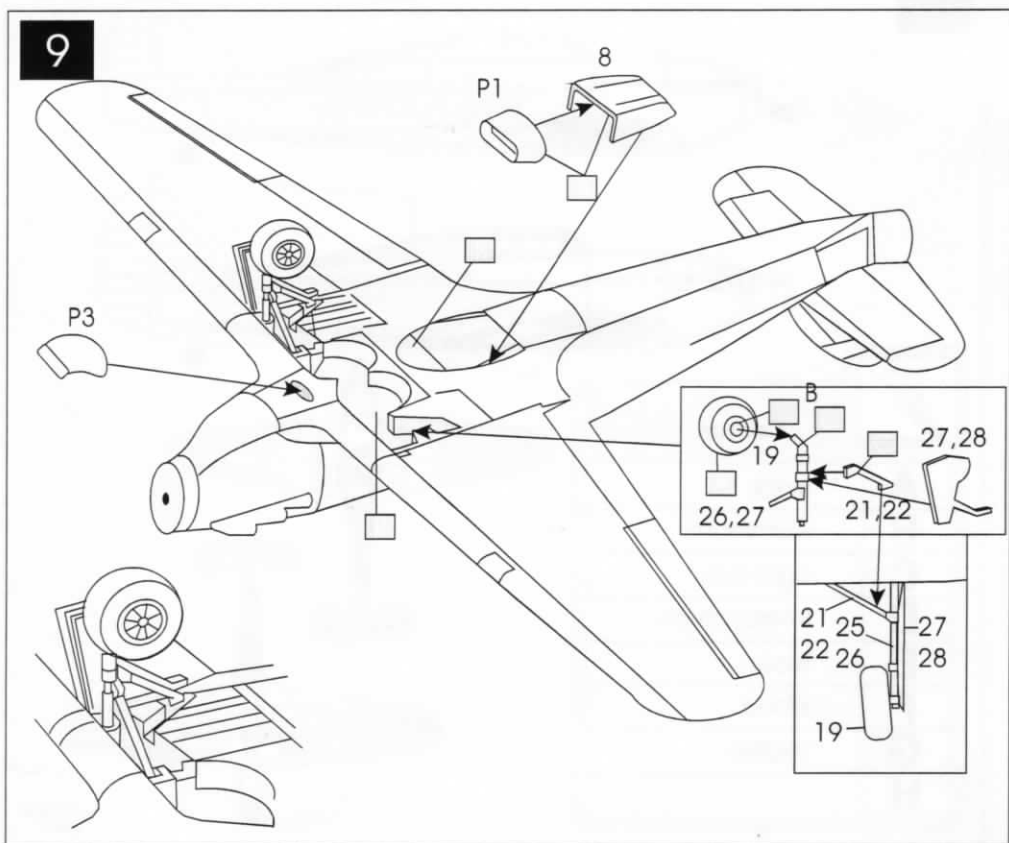
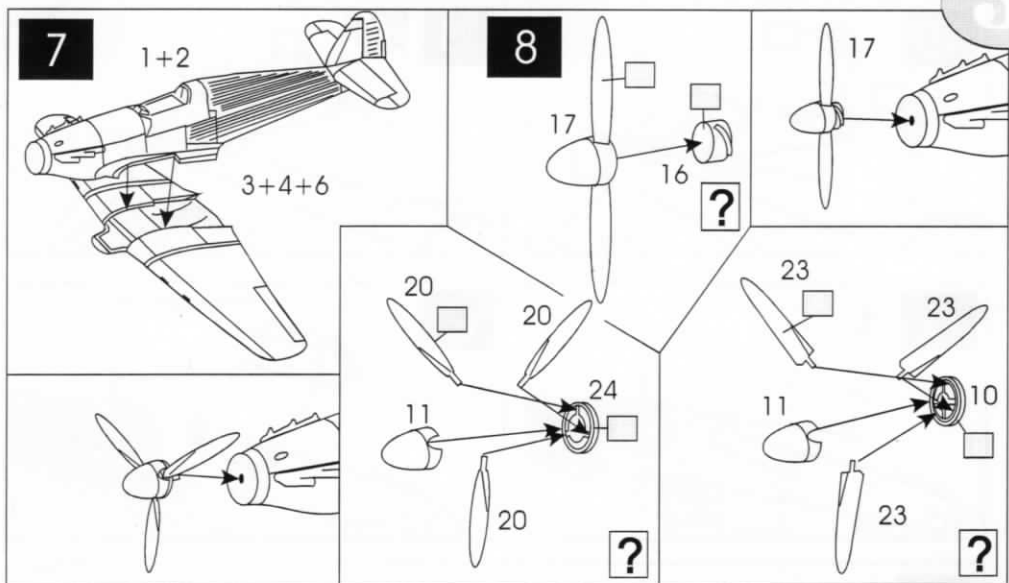

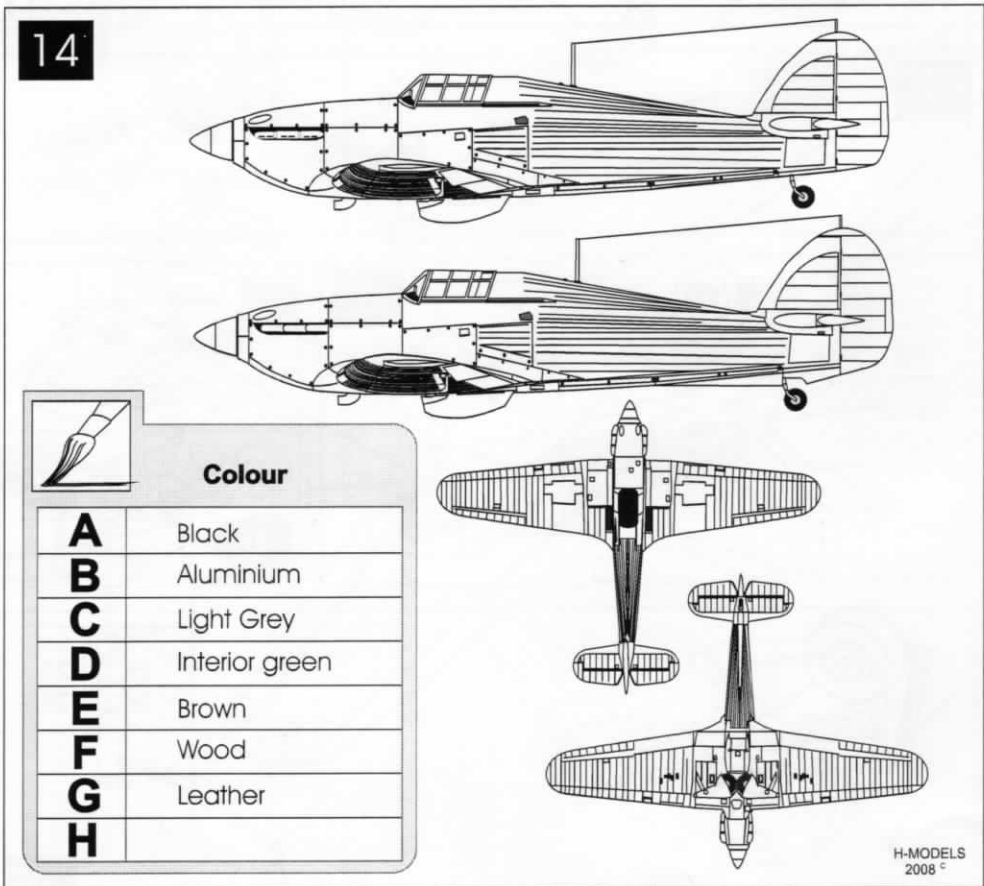
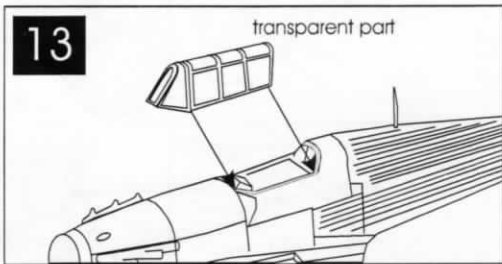
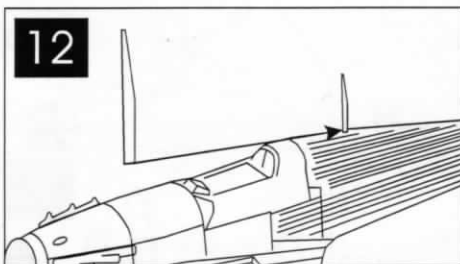
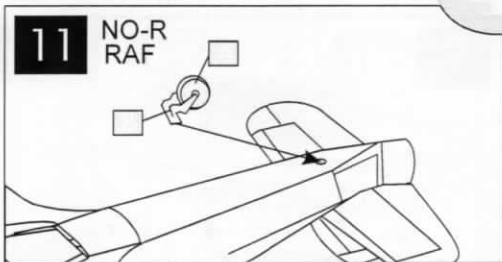
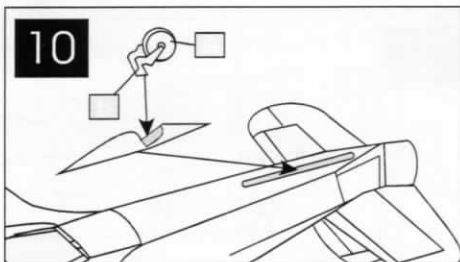

1 Hawker Hurricane Mk. I., NO-R,
No. 85 Sqn, Debden, England 1939



2 Hawker Hurricane Mk. I., KT-A,
No. 32 Sqn, Biggin Hill, England 1939

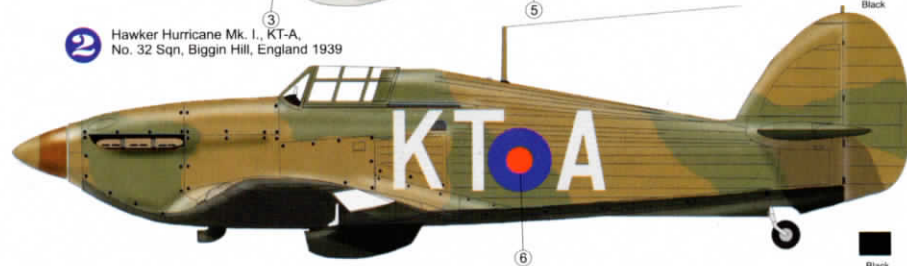

3 Hawker Hurricane Mk. I., DU-J,
312. Czechoslovak Sqn, Pilot P/O Alois Vasatko, October 1940



4 Hawker Hurricane Mk. I., Experimental camouflage, 1940

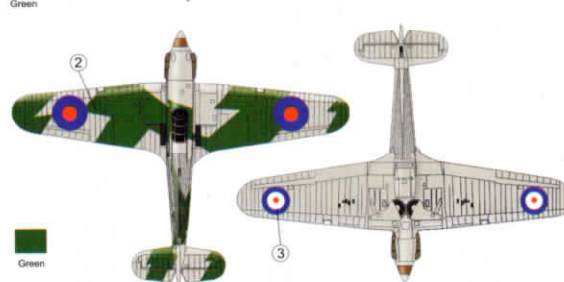
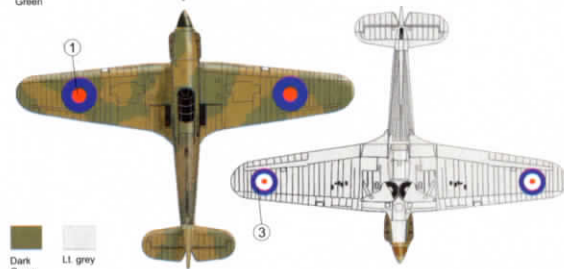
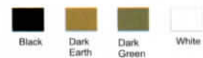
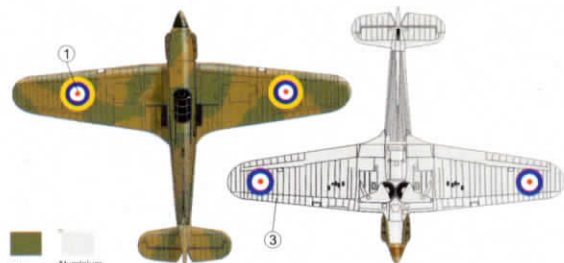
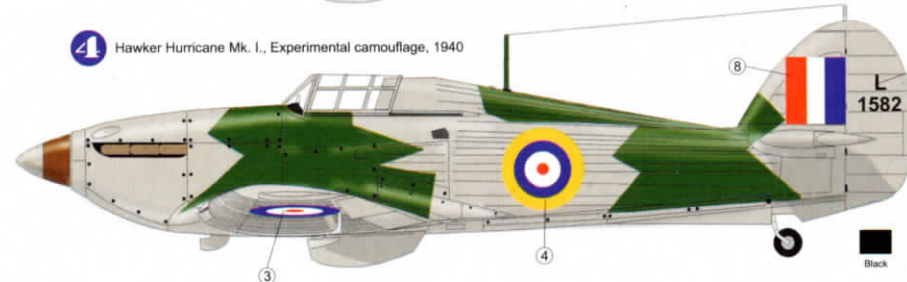

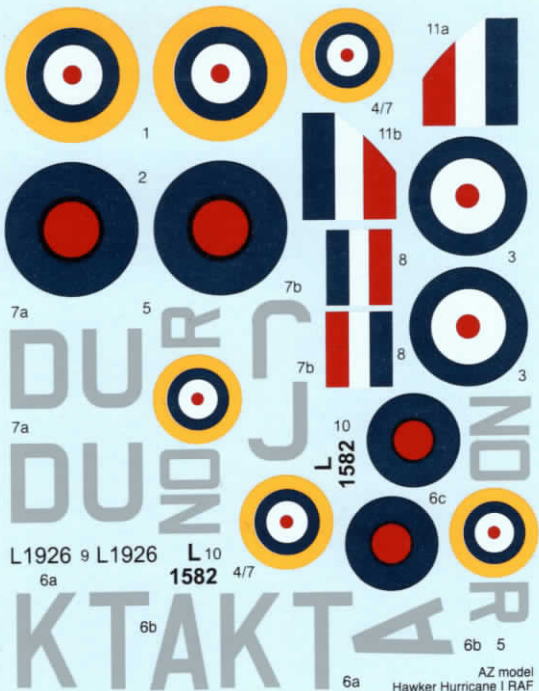

L1926 9 L1926
6a

L10
1582 4/7

L
1582

AZ model
Hawker Hurricane I RAF