

**BAe Sea Harrier FRS.2, ZA195, aboard HMS Ark Royal, 1988.**  
ZA195 was the original prototype Mk.2 and conducted trials aboard the 'Ark' albeit devoid of the Blue Vixen radar!  
Overall Dark Sea Grey, with Dark Sea Grey radome.  
Note the nose pitot and the calibration markings.

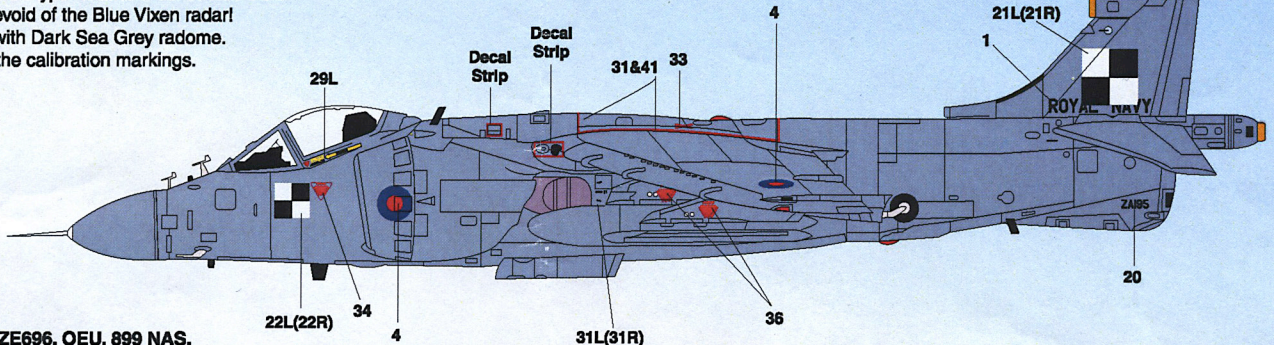

**BAe Sea Harrier FA.2, ZE696, OEU, 899 NAS, RNAS Yeovilton, 1994.**  
ZE696 was given the '712½' modex number following the loss of two aircraft numbered '713' and thus placed '712½' between '712' and '714'!  
Overall Medium Sea Grey, with Dark Sea Grey radome.

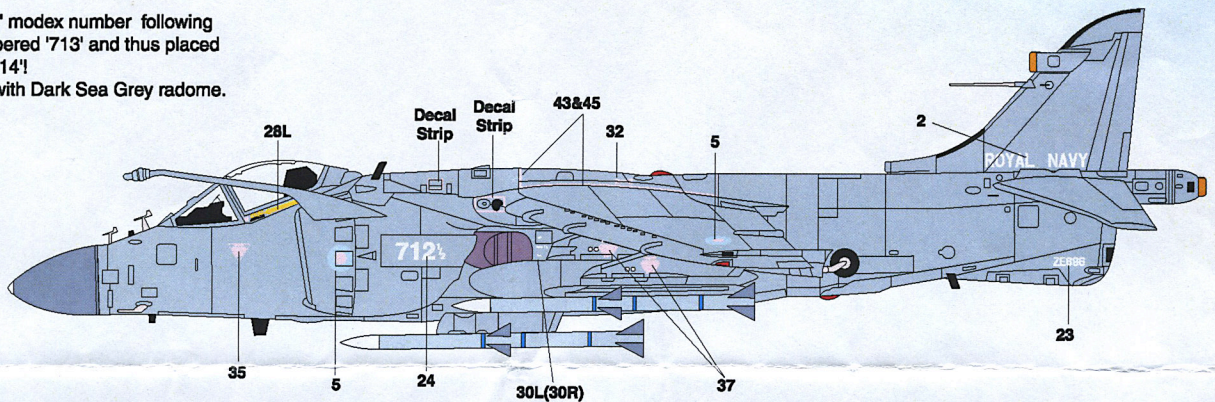

**BAe Sea Harrier FA.2, ZH796, of 899 NAS, RNAS Yeovilton, 1994.**  
Overall Medium Sea Grey, with Dark Sea Grey radome.  
ZH796 had the wing roundels applied on the port upper and starboard lower surfaces only.

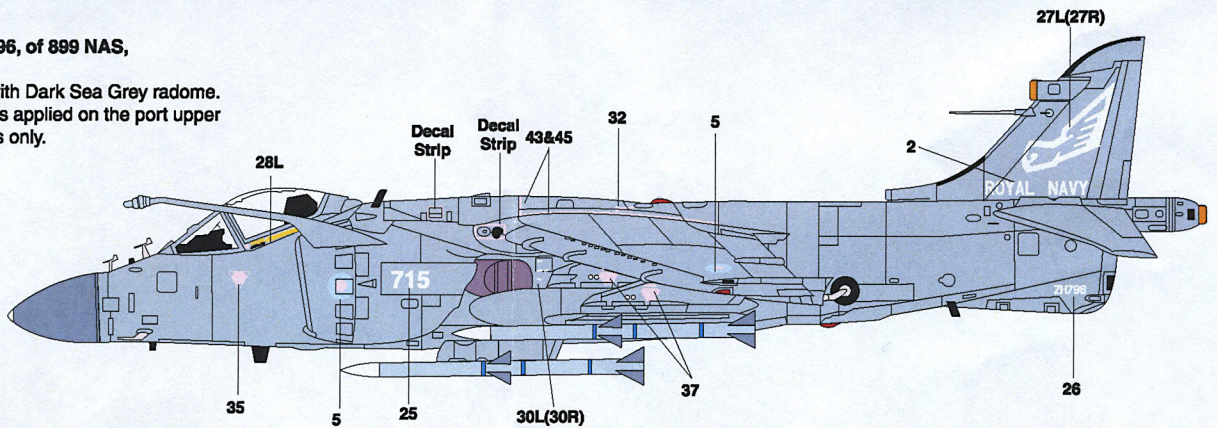

**Starboard  
General Emergency Data Placement**

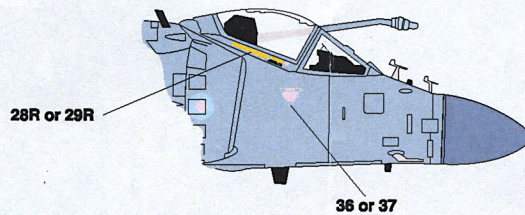

**Recommended Kits**

- 1:72 Scale - ESCI Sea Harrier FRS1
- Italeri Sea Harrier FRS1
- Hasegawa Sea Harrier FRS1
- Fujimi Sea Harrier FRS1

Model Alliance Conversion set CS-26 is recommended for the FA2 conversion in 1:72 Scale.

1:48 Scale - Airfix Sea Harrier FA2

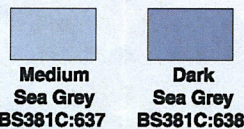

**Reference Sources:**

- Scale Aircraft Modelling Vol 1 No. 6
- Scale Aircraft Modelling Vol 24 No. 6
- Scale Aircraft Modelling Vol 21 No. 4
- Scale Aviation Modeller Vol 1 No. 6
- Scale Aviation Modeller Vol 7 No. 10
- Scale Aviation Modeller Vol 8 No. 9
- Air Forces Monthly May 2002

'The Sharp End' by Neil Mercer, Airline Publishing  
Harrier Inside & Out by Mark Attrill





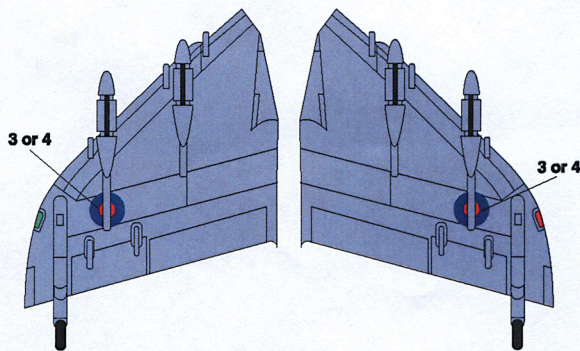
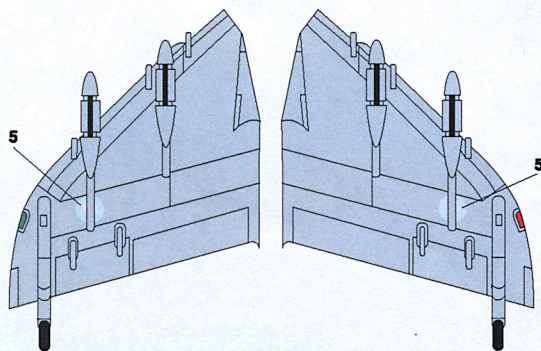
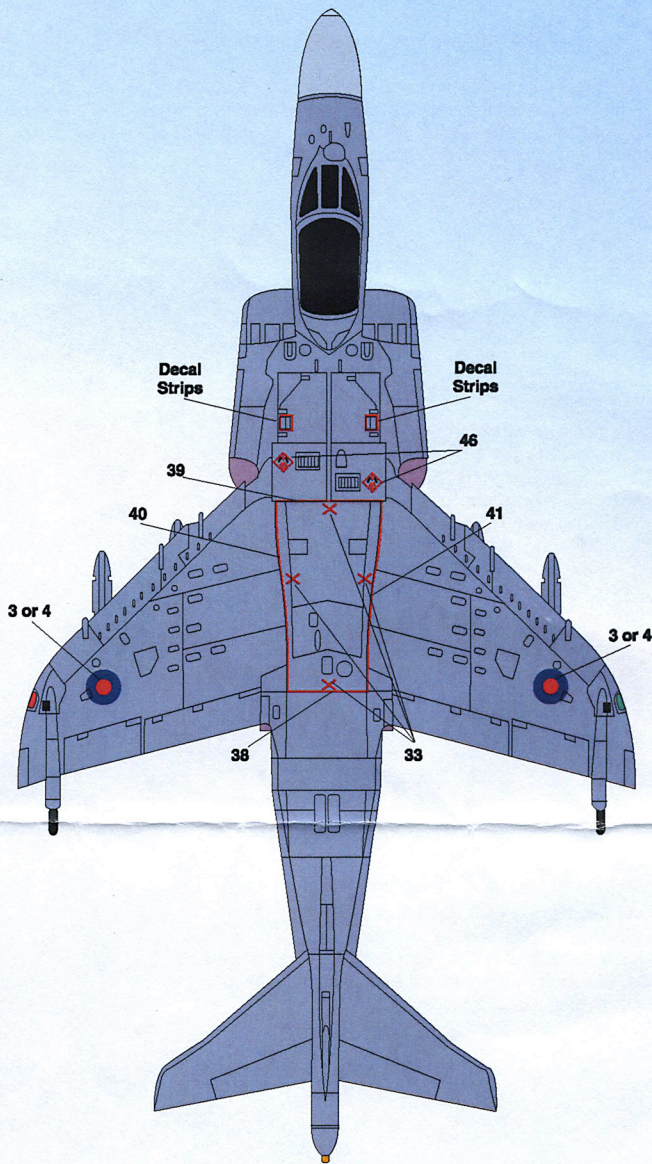
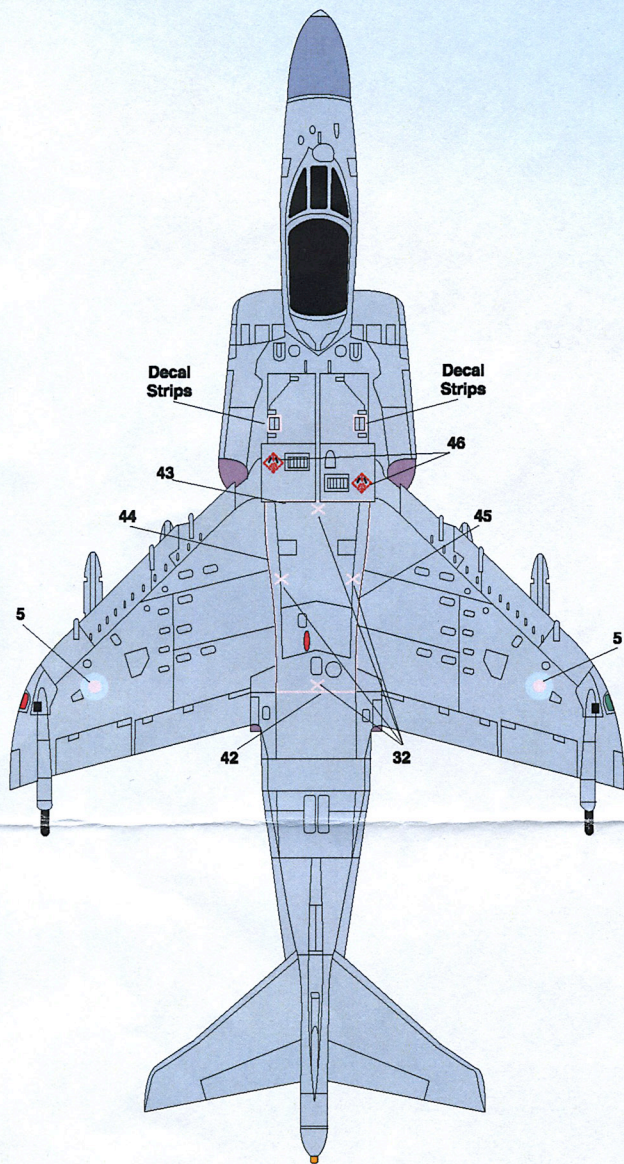

**Note:**  
Aircraft ZH796 had roundels placed  
on the port upperwing and starboard  
lowerwing only.

**Recommended Paints:**  
BS381C:637 Medium Sea Grey  
Xtracolor X003, Humbrol 165  
BS381C:638 Dark Sea Grey  
Xtracolor X004, Humbrol 164

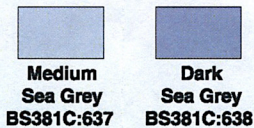

The Aviation Workshop & International  
Model Alliance Decals - UK are trading  
names of The Aviation Workshop  
Publications Ltd & Gary Madgwick



**BAe Sea Harrier FRS.2, XZ439, 1993.**  
Flown from Elgin Air Force base, USA.  
XZ349 was the second development aircraft.  
Overall Medium Sea Grey with the radome  
being Dark Sea Grey. Note the lack of fin pitot.

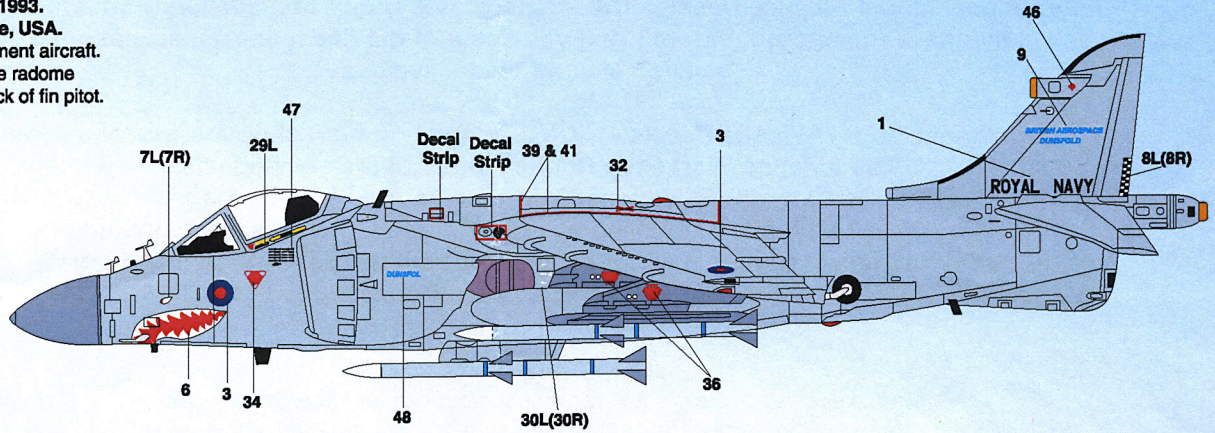

**BAe Sea Harrier FRS.2, ZD611, of 899 NAS 1994.**  
Based at RNAS Yeovilton.  
Overall Dark Sea Grey. Radome Medium Sea Grey.

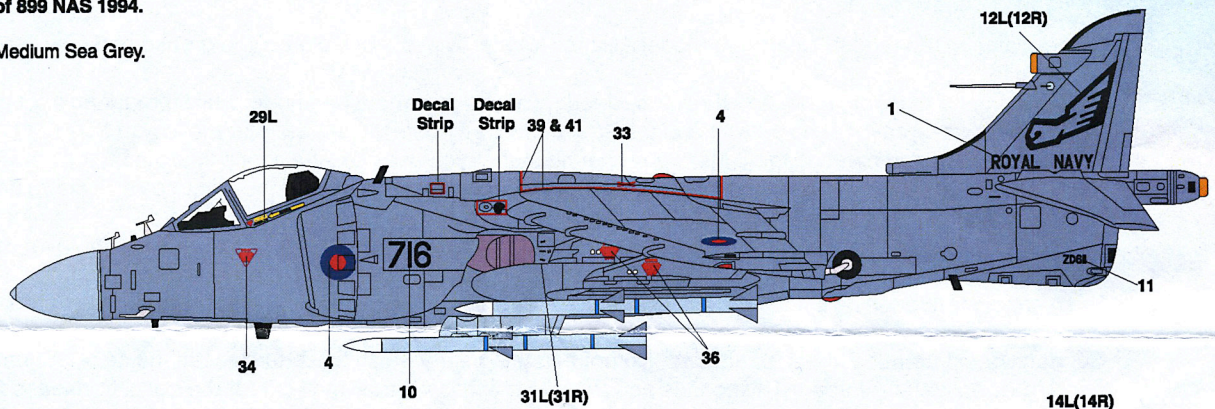

**BAe Sea Harrier FA.2, ZA175, of 800 NAS 2002.**  
Based at RNAS Yeovilton.  
Overall Medium Sea Grey. Radome Dark Sea Grey.

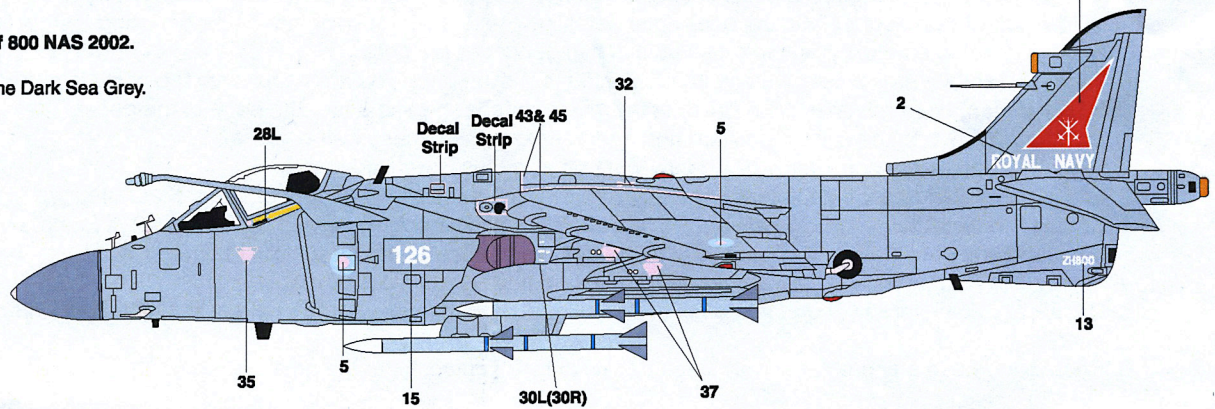

**BAe Sea Harrier FA.2, ZH799, of 801 NAS,  
RNAS Yeovilton, 1999.**  
Overall Medium Sea Grey, with Dark Sea Grey radome.

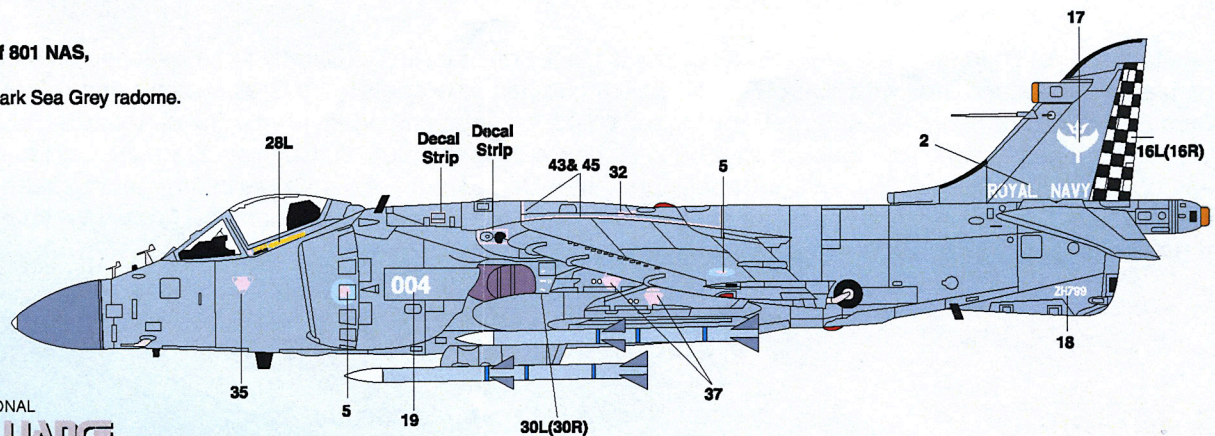



## A PASSION FOR PERFECTION

International Model Alliance Decals - UK is a dedicated group of modellers from around the world that have joined together to bring you some of the finest decals, accessories, kits, etched sets and books available.

International Model Alliance Decals - UK & The Aviation Workshop are trading names of The Aviation Workshop Publications Ltd & Gary Madgwick. The On-Target Publications, AIRframe Journal & Airfix Magazine for Aircraft Modellers are all names registered to The Aviation Workshop Publications Ltd and may not be used without the permission in writing of the The Aviation Workshop Publications Ltd.

### Decals Instructions:

These decals are a high quality product produced for I.M.A Decals - UK by Fantasy Print Shop. The decals are very thin but very strong and flexible.

1. Before painting the model, clean with Model Alliance 'Model Wipes'. This cleans the grease and any dust from the surface.
2. We recommend that you wear Model Alliance 'Model Gloves' to handle the model whilst preparing it for painting.
3. For best results, spray the model with a Light Grey primer, any defects can then be made good.
4. For demarcation and camouflage lines, we recommend that you use Model Alliance 'Masking Film'.
5. If you wish to use a decal fixing and finishing system, we recommend you use the Microscale System, do not use strong decal solvents such as Solvaset.
6. Once you are happy with the painting of the model, coat it in a clear gloss finish, this can either be over the entire model if the model is finished glossy or spot gloss finish in the areas that have a decal. A good surface finish are clear floor shine's such as Johnson wax - Klear. This is sold under different names around the world. Klear can be either brushed on or sprayed.
7. Cut each decal from the sheet as needed. Do not trim the clear varnish finish to close to the decal. Submerge the decal in warm water for about 10 seconds and remove to a flat surface and wait for the decal to release from the backing sheet. A small amount of washing up liquid in the warm water helps the decal release from the sheet.
8. These decals do not require a decal setting solution to lay flat or to conform to the model contours.
9. With a pair of tweezers to hold the backing sheet, slide the decal in position on the model using a small soft brush. Do not use an old painting brush as bits can get under the decal.
10. Carefully remove any excess water with a soft cloth or tissue once you are happy with the position of the decal. Should you make a mistake, dip a brush in the warm water and ease under the edge of the decal. The decal will then easily move to the correct position and again remove the excess water.
11. When the decals are completely dry, gently wipe off all excess decal adhesive.
12. Leave the model to dry completely, spray or paint over the decals with a further coat of Klear or gloss.
13. Should the decal silver for any reason, this is because small air bubbles are under the decal. If found, prick with a pin and apply a small drop of Micro Sol to the decal and allow to dry for up to 12 hours.
14. Finally, coat the model with the required finish, either gloss, semi gloss or matt.
15. Decals are best stored flat and in a cool, dry place and should not be stored in direct sunlight, hot or humid conditions.
16. Should you have any problems with these decals please contact us at the address below.

**Sea Harrier FA2 Detailing:** Interior Cockpit colour is Dark Admiralty Grey (Shortly to be released as Model Alliance Paint). Instrument panels are Grey with Black dial and switch and panels. Panels have Grey switch's and reference to World Air Power Journal and On-Target 'Spot Light' books are recommended. Martin Baker Mk 10H Ejector seats have Dark Grey frames, with Yellow/Black ejector handles below the seat cushion. Cushion seats are generally Dark Green with the head box cushion Dark Black/Grey. Lower belts are either Dark Green, upper straps in orange with head box restraining straps in Dark Green. Undercarriage legs are Light Aircraft Grey. Wheel bay interiors are Glossy White but get very dirty. Air brakes/ speed brakes are Dark Sea Grey internally.



INTERNATIONAL  
**MODEL ALLIANCE**

Decals - UK

[www.theaviationworkshop.co.uk](http://www.theaviationworkshop.co.uk)

The Aviation Workshop  
Brook Barn, Letcombe Regis,  
Wantage, Oxon, OX12 9JD, UK