

TIRPITZ SPECIFICATIONS

Displacement, standard ..... 42,900 tons  
 Displacement, maximum ..... 52,600 tons  
 Length overall ..... 251 m  
 Length waterline ..... 241.5 m  
 Beam ..... 36 m  
 Draught ..... 9 m  
 Maximum speed ..... 30.8 knots  
 Aircraft ..... Ar 196 - 6

ARMAMENT (1941)

8- 38 cm QFG L/47 twin turret  
 12- 15 cm QFG L/55 twin turret  
 16-105 mm L/65 gun twin mount  
 16- 37 mm A/A gun twin mount  
 10- 20 mm A/A gun single mount  
 8- 53.5 cm torpedo tube  
 40- 20 mm A/A gun, quadruple mount

Complement ..... 2608 men  
 Radius of operation ..... 10,200 nautical miles  
 Fuel reserve maximum (oil) ..... 8,641 tons  
 Fuel reserve normal (oil) ..... 2,952 tons  
 Builder ..... Wilhelmshaven Naval Dockyard  
 Completed ..... February 1941

ITEM 78003

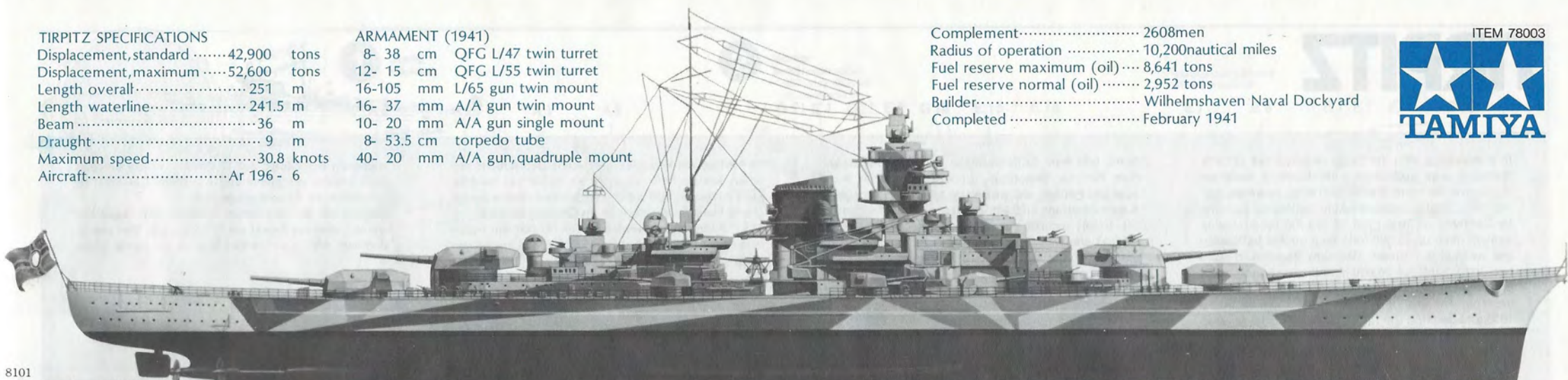

8101

1/350テルピッツ(英独)

# 1:350 GERMAN BATTLESHIP TIRPITZ





In accordance with the treaty of Versailles of 1919, Germany was prohibited from building warships displacing for more than 10,000 tons; however, during 1935, England consented to battleship building by Germany up to a total of 183,750 tons. Having already used up 82,000 tons on a pocket battleship and two battle cruisers, Germany decided to build two battleships of 35,000 ton displacement each (the limit set by the London Treaty for individual battleships). The first of these was laid down on 1 July 1936 and became the famous Bismarck. The second keel was set on 24 October 1936, and was christened Tirpitz at her launching on 1 April 1939. On the night of 19 July 1940, during her fitting out at Wilhelmshaven, she was unsuccessfully attacked by British aircraft, and was commissioned ready for action on the 25th of February 1941. During late September 1941 the Tirpitz joined the Baltic fleet, and was to depart into the Atlantic, with the Admiral Sheer, in November. For some reason this plan was called off, and the Tirpitz was transferred to Northern Norway in January 1942 for operations against

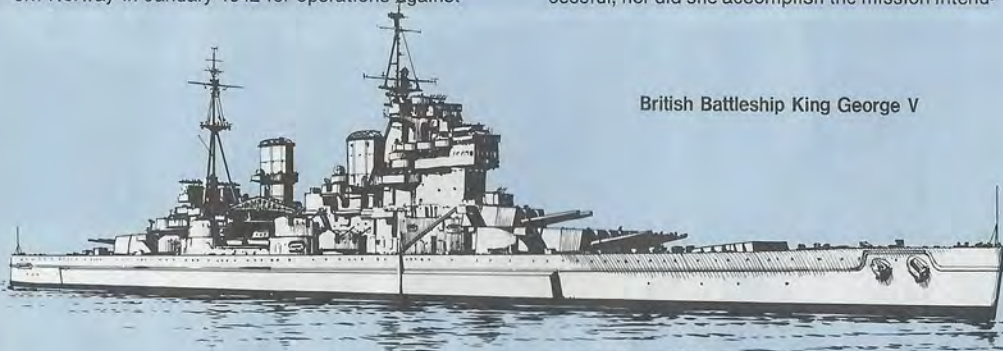

British Battleship King George V

the naval convoys operating in that area. These operations were, for the most part, unsuccessful and the Tirpitz was again unsuccessfully attacked by British bombers the night of 27 April 1942 while in Trondheim. During the operation against the convoy PQ-17, on 5 July 42, they had to prematurely break off operations due to receiving an unsuccessful torpedo attack from the Russian submarine K-21. Between the 6th and 9th of September 1943, the Tirpitz destroyed many important land installations while on operations against Spitsbergen. On 22 September, while in the Alta Fjord, she was attacked by two midget British submarines and was seriously damaged by bottom mines planted by them, and was not again available for service until March 1944. On 3 April 1944, the Tirpitz sustained 14

bomb hits from British aircraft flown from the carriers Furious, Victorious, Emperor, Searcher, Purser and Fencer, and was again seriously damaged. A second attack on 5 April was unsuccessful due to the timely smoke screen laid down. From 22-29 August she was repeatedly attacked by carrier aircraft, and again received damaging hits. On 15 September 1944, 4.5 ton bombs were used for the first time by the British, and hits and near misses rendered the Tirpitz unseaworthy. She was moved to Tromsø on 17 October, into shallow water, to be used as a floating battery. Repeated attacks on 29 October were repulsed, but on 12 November 1944 she was attacked by 36 British bombers carrying 5.5 ton bombs, and was mortally damaged by three direct hits. She capsized with a loss of 1,204 seamen. Between 1948-1957, the Tirpitz was broken up for scrap by a German-Norwegian company at the site of her sinking. An unglorious end to a former queen. Based upon the time the Tirpitz was in operation, you might get the feeling that she was not very successful, nor did she accomplish the mission intend-

ed, but this is not really a fair appraisal. With the Tirpitz lurking in a Norwegian fiord, she posed a constant threat to the British home fleet, and for nearly three years constrained the British Royal Navy to retain two modern battleships plus an aircraft carrier in northern waters, that could have been much better employed in other theatres of the war. Attempts by the British to entice the Tirpitz out of her lair proved unsuccessful, and between January 1942 and November 1944 subjected her to 13 attacks by a total of 600 British aircraft, which amounted to an incredible total of manpower and war material. The latent threat of the Tirpitz, a thorn in the side of the allies, was not eradicated until 12 November 1944 when the 29 Lancaster bombers closed the chapter on this remarkable episode of the war.

Im Vertrag von Versailles 1919 wurde Deutschland verboten, Kriegsschiffe mit mehr als 10.000 ton Verdrängung zu bauen. 1935 willigte England ein, dass nunmehr Deutschland Schlachtschiffe im Gesamtgewicht bis zu 183.750 ton gebaut werden dürfen. 82.000 ton waren bereits mit kleineren Schlachtschiffen und zwei Kreuz-

wiederum beschädigt. Am 17. Oktober wurde sie dann nach Tromsø geschleppt und in leichtem Gewässer als schwimmende Batterie eingesetzt. Die Angriffe am 29. Oktober konnten noch abgewehrt werden, aber der Angriff am 12. November 1944 von 36 Bombern mit 5,5 to Bomben brachte 3 schwere Treffe

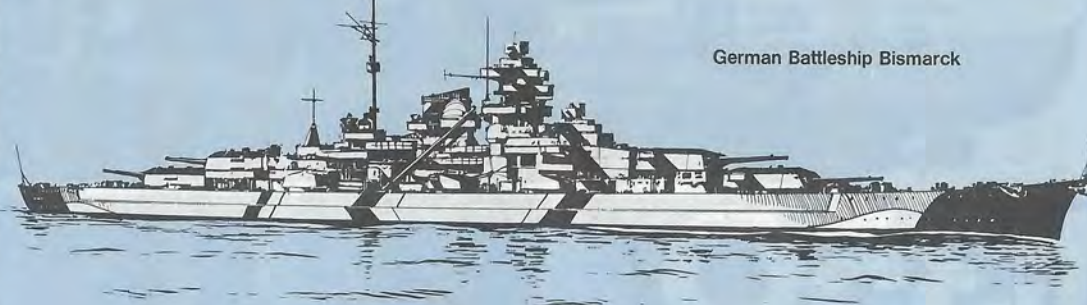

German Battleship Bismarck

zern belegt. Deutschland beschloss nun, zwei weitere Schlachtschiffe mit je 35.000 ton zu bauen.

Als erstes wurde die Bismarck am 1. Juli 1936 auf Kiel gelegt, gefolgt von der Tirpitz am 24. Oktober 1936. Der Stapellauf erfolgte am 1. April 1939.

Bereits am 9. Juli 1940 wurde die Tirpitz während des Ausbaues erfolglos in Wilhelmshaven von britischen Flugzeugen angegriffen. Die Fertigstellung mit Übergabe an die Marine war am 25. Februar 1941. Ende September wurde die Tirpitz der baltischen Flotte zugeteilt und sollte im November unter Admiral Scheer in den Atlantik fahren. Dieser Plan wurde abgesagt und die Tirpitz wurde im Januar 1942 nach Nord-Norwegen abgestellt für Operationen gegen die Schiffs-Konvoys aus Amerika nach Russland.

In der Nacht zum 27. April 1942 wurde dann die Tirpitz von britischen Bombern erfolglos angegriffen (in Trondheim). Am 5. Juni 1942 war sie im Einsatz gegen den Konvoy PQ-17, wurde von dem russischem U-Boot K-21 erfolglos angegriffen.

Zwischen dem 6. und 9. September 1943 zerstörte die Tirpitz wichtige Landeinrichtungen in Spitzbergen. Am 22. September konnten zwei britische Kleinst-U-Boote im Alta-Fjord rumpfminen an der Tirpitz anbringen und diese schwer beschädigen.

Erst im März 1944 konnte die Tirpitz wieder eingesetzt werden. Am 3. April 1944 erhielt die Tirpitz 14 Bombentreffer von britischen Trägerflugzeugen. Ein zweiter Angriff am 5. April war nicht erfolgreich durch den zu dieser Zeit bestehenden Nebel.

Weitere Angriffe und Beschädigungen erfolgten in der Zeit vom 22. bis 29. August.

Am 15. September 1944 wurden zum ersten Mal von den Engländern 4,5 to Bomben eingesetzt, die Tirpitz

und die Tirpitz mit 1204 Seelauten zum Kentern. Zwischen 1948 und 1957 wurde die Tirpitz von einer deutsch-norwegischen Firma an der Stelle ihres Unterganges verschrottet.

Es könnte der Eindruck entstehen, dass die Tirpitz während ihres Einsatzes nicht sehr erfolgreich gewesen wäre, dies ist jedoch nicht so.

Die Tirpitz, in einem norwegischem Fjord auf der Lauer liegend, war eine konstante Gefahr für die Briten und für nahezu 3 Jahre konnte sie britische Schlachtschiffe und Träger im nördlichen Gewässer festhalten, die viel besser auf anderen Kriegsschauplätzen eingesetzt werden konnten oder benötigt wurden.

Versuche der Briten, die Tirpitz aus ihren Verstecken hervorzulocken, mit 13 Angriffen von insgesamt 600 britischen Flugzeugen zwischen Januar 1942 und November 1944, machte schon den Einsatz einer unglaublichen Schlagkraft mit Unmengen von Kriegsmaterial notwendig.

Die ständige Gefahr der Tirpitz, war ein Dorn in der Flanke der Alliierten - bis zum 12. November 1944.

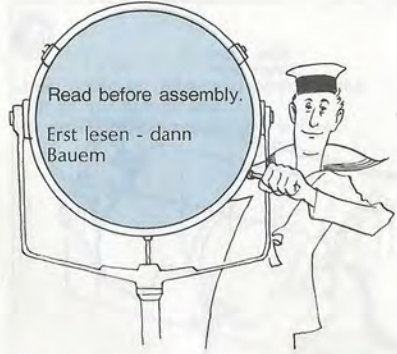

★Study the instructions and photographs before commencing assembly.  
 ★You will need a sharp knife, a screwdriver, a file and a pair of pliers.  
 ★Do not break parts away from sprue, but cut off carefully with a pair of pliers. Use cement sparingly. Use only enough to make a good bond. Apply cement to both parts to be joined.  
 ★The motorized model will need four UM1 dry cells.

★Vor Beginn die Bauanleitung studieren und den Nummern nach die Elemente zusammenbauen.  
 ★Bauteile nicht vom Spritzling abbrechen, vorsichtig abschneiden oder abwickeln.  
 ★Teile vor Kleben zusammenhalten, auf genauen Sitz achten. Nicht zuviel Klebstoff verwenden. Kleine Teile hält man mit Pinzette fest.  
 ★4 UM1 Batterien sind im Kit nicht enthalten.

🔵 This mark shows the colour.  
 🟡 Zeichen für Bemalung.

**1** Stand Ständer

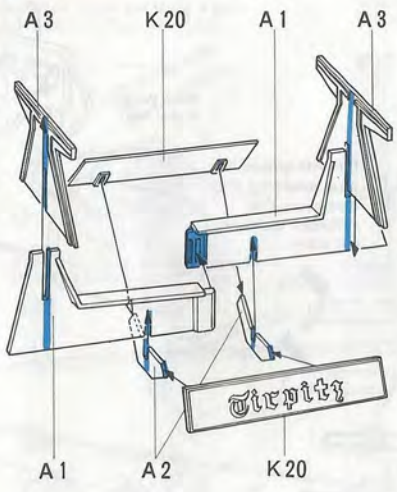

**2** Screw Schiffsschraube

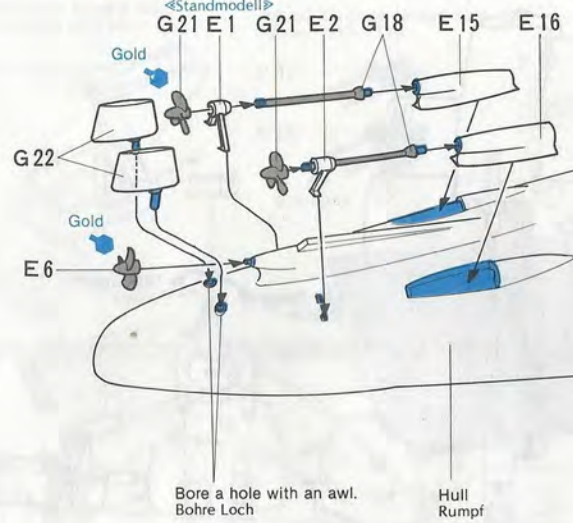

«Motorized Model» «Elektromodell»

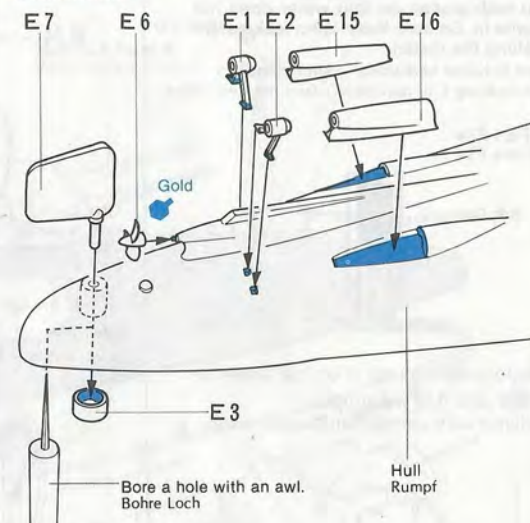

**3** Motorized Model Parts Teile für Elektromodell

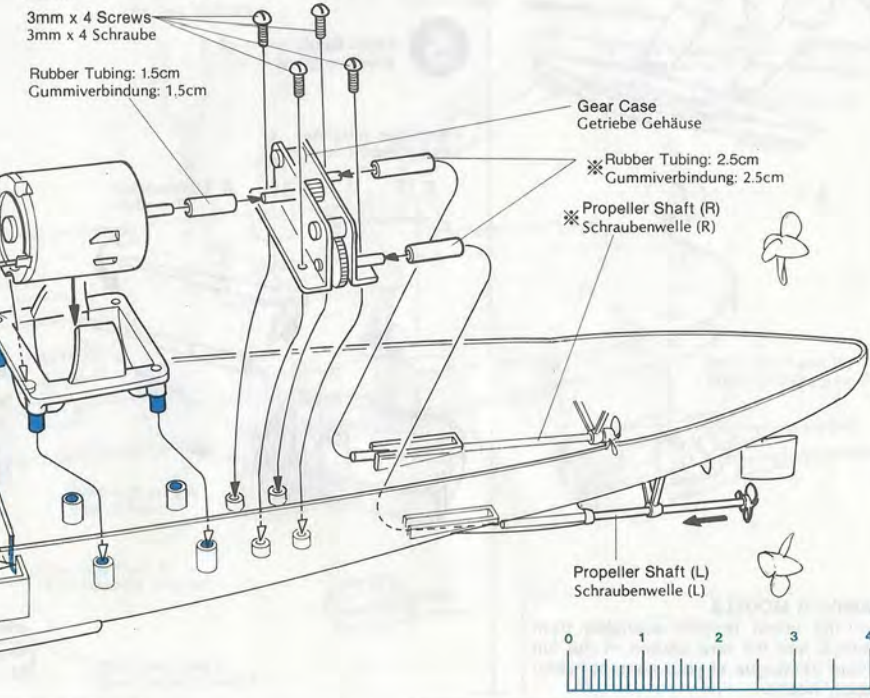
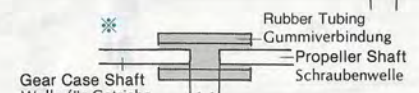
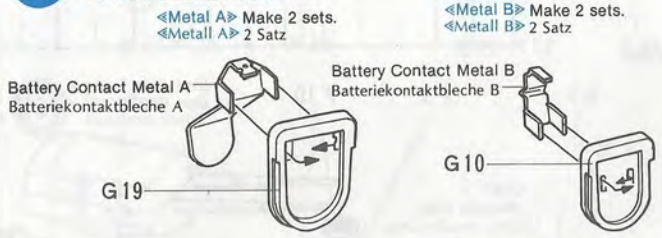

**2**

This kit is designed either for display or motorized. In either case, make holes for rudders G22 or E7 as shown. Ob Stand- oder Elektromodell, auf jeden Fall die Löcher für die Ruder G22 oder E7 bohren.

**3**

If you choose the display model, proceed to step 5 on page 4. In inserting shaft into screws, use the runner of F parts as shown in the diagram at right. Wenn Standmodell bei Step 5 auf Seite 4 weiterbauen. Teile F als Unterlage nehmen.

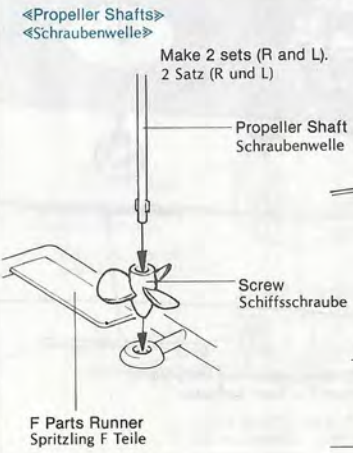

4

Switch must be wired before it is attached to hull. After affixing C10 to hull, fill up with grease so that water does not come in. Be sure there is no leak before sailing the model.

Erst Schalter verkabeln—dann einbauen.  
Abdeckung C10 aufkleben, dann mit Fett füllen.

«Part F5»  
«Teile F5»

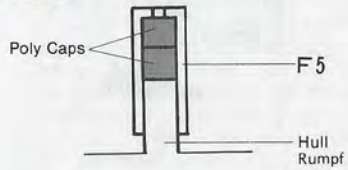

★Before sailing, put it on the water to make sure it is water tight.  
★Rumpf auf wasserdichten Bau überprüfen.



4 Switch  
Schalter

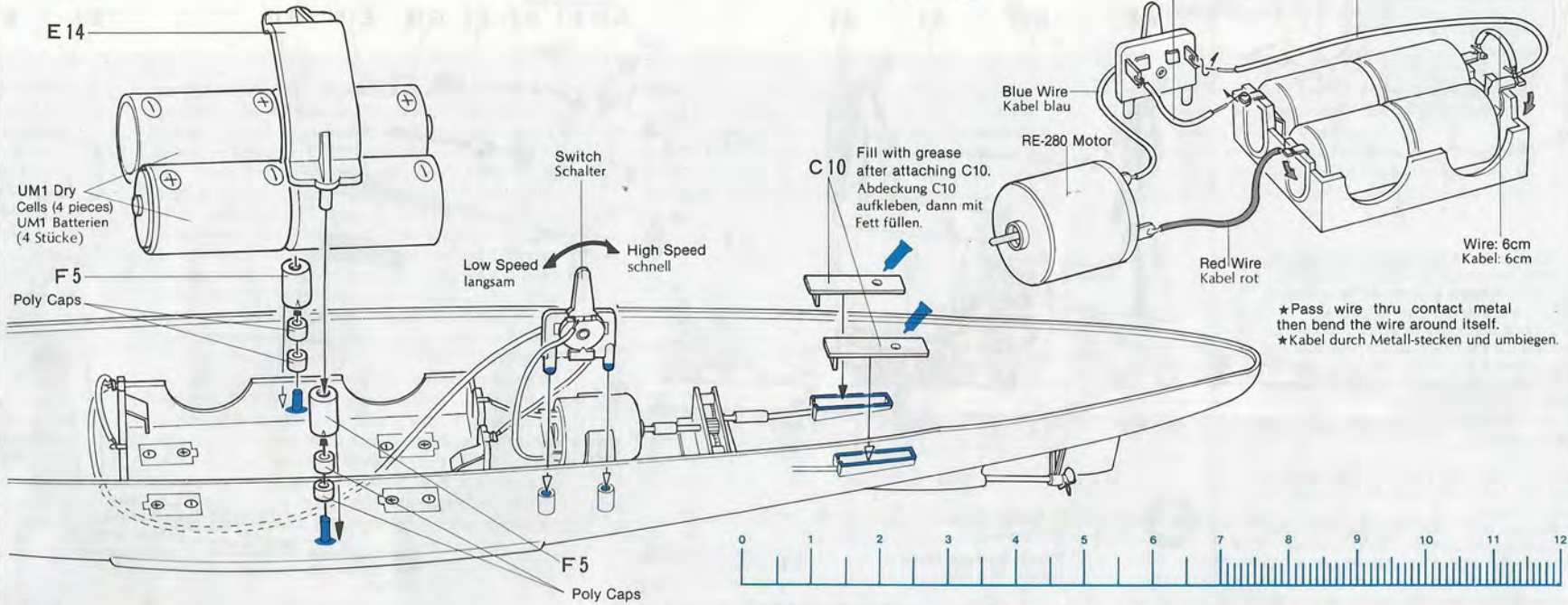

★Pass wire thru contact metal then bend the wire around itself.  
★Kabel durch Metall-stecken und umbiegen.

5 Front Deck  
Vorderes Deck

«38cm Gun Turret A»  
«38cm Geschütz Turm A»

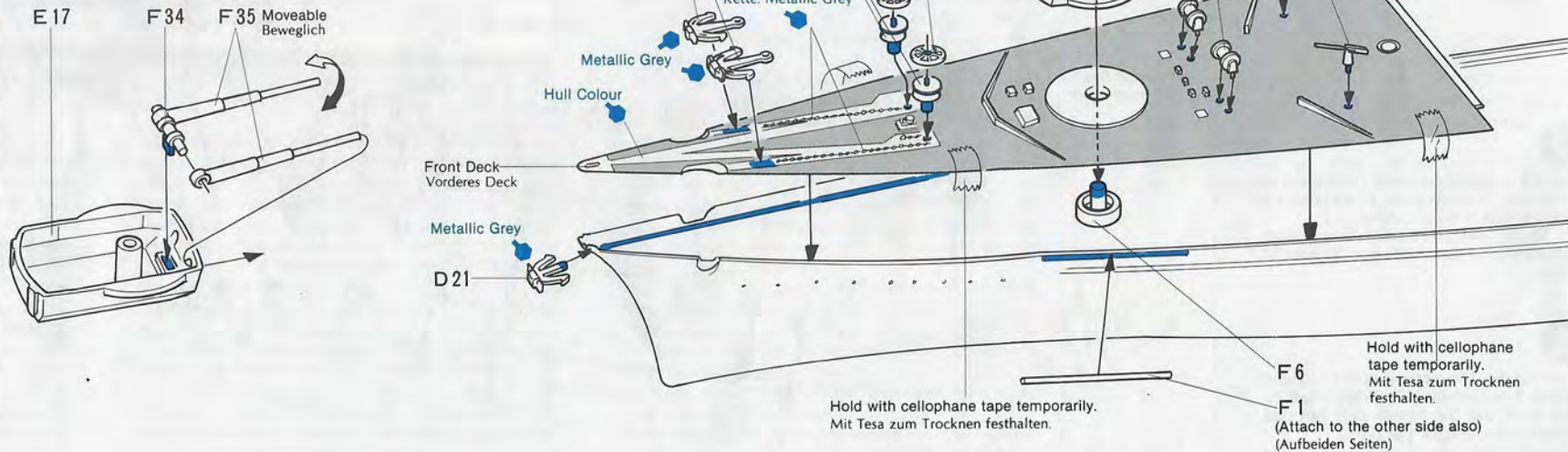

**TAMIYA'S MODELS**  
For the latest models available from Tamiya, see the new edition of the full colour catalogue at your nearest hobby supply house.

7

Make holes at depressed circle marks with an awl beforehand.  
Vor der Innenseite aus ein Loch bohren.

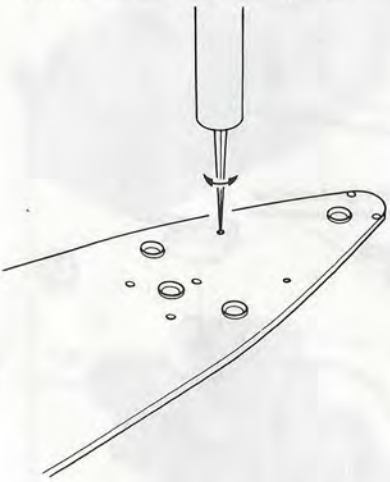

6

**Guns  
Kanonen**

«15cm Gun Turret A» Make 4 sets.  
«15cm Geschütz Turm A» 4 Satz.

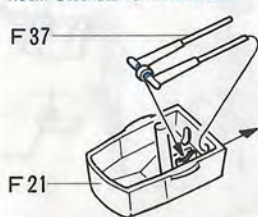

«15cm Gun Turret B» Make 2 sets.  
«15cm Geschütz Turm B» 2 Satz.

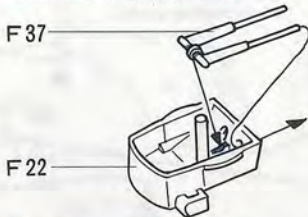

«38cm Gun Turret B» Make 2 sets.  
«38cm Geschütz Turm B» 2 Satz.

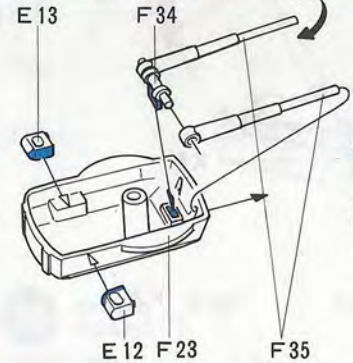

«38cm Gun Turret C» Make 1 set.  
«38cm Geschütz Turm C» 1 Satz.

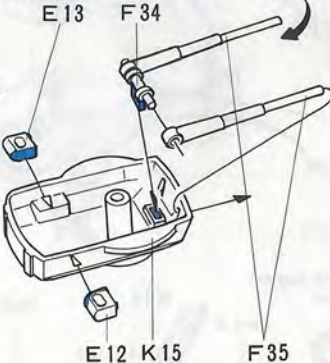

7

**Rear Deck  
Hinteres Deck**

«20mm AA Gun» Make 2 sets.  
«20mm Flak» 2 Satz.

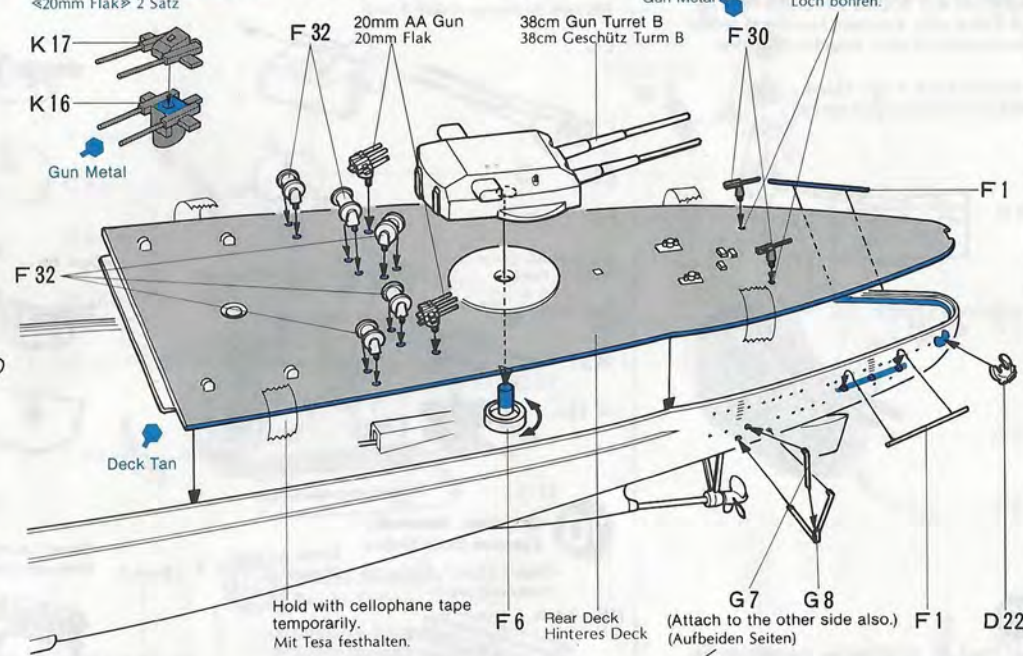
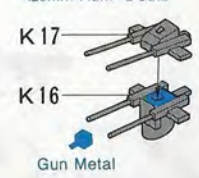

8

If you are to motorize your model, first make a hole in the specified place on deck base from the underside. All the turrets are moveable. Refer to the diagram below when attaching F-3.  
Wenn Motor eingebaut wird, dann mit Messer Schlitz machen (siehe Bild). Alle Türme sind beweglich. Darauf achten, dass Ring F3 nicht an Deckunterseite geklebt wird.

«Part F3»  
«Teil F3»

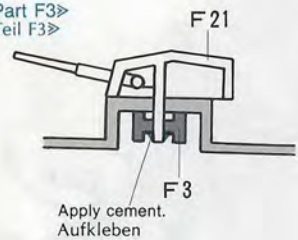

8

**Gun Deck  
Kanonen Deck**

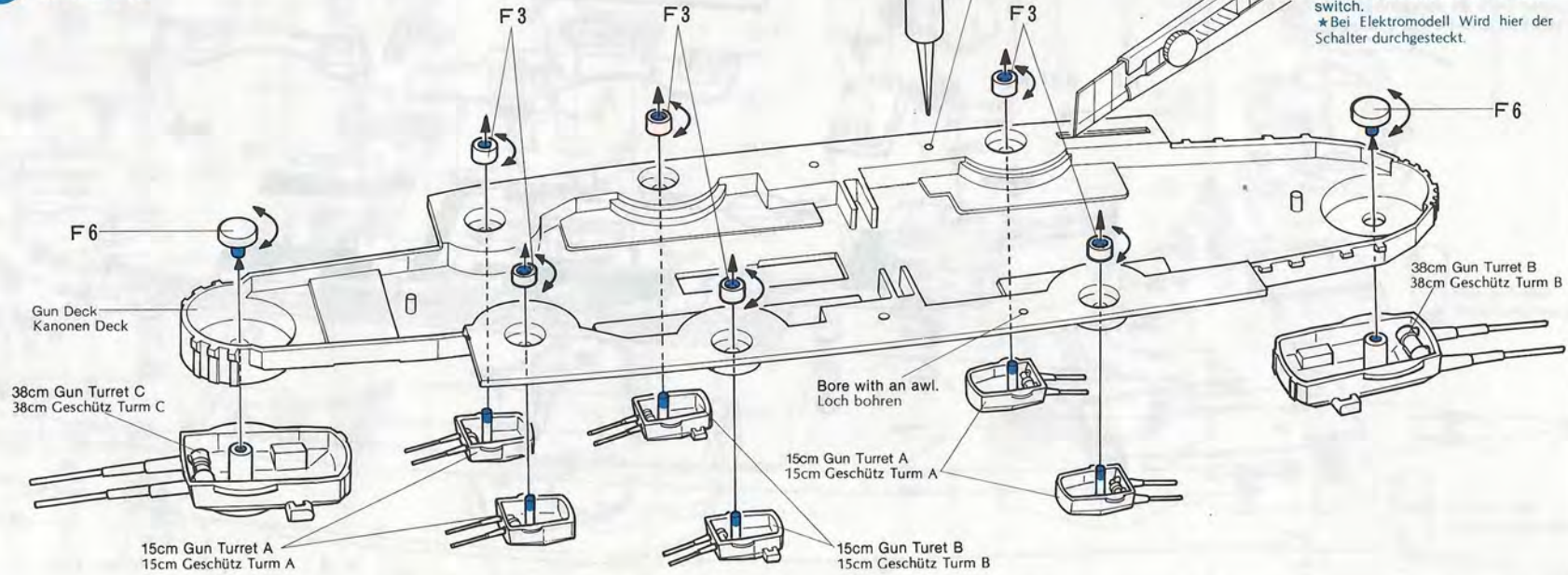

9

Barrels F36 of high angle guns may be attached at an angle you like. Also, turrets and barrels of other guns may be attached at any angles you think fit.  
Die Rohre aller Kanonen können in jedem gewünschten Winkel eingebaut werden.

«105mm High Angle Gun»  
«105mm Steilfeuereschütz»



«Reference Photo»



9

### High Angle Guns Steilfeuereschütz Einbau

«105cm High Angle Gun» Make 8 sets.  
«105mm Steilfeuereschütz» 8 Satz

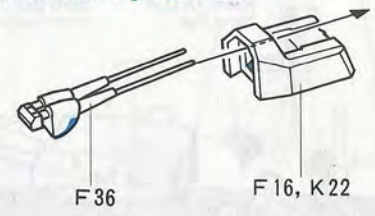

«20mm AA Gun»  
«20mm Flak»

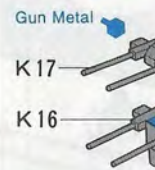

«37mm AA Gun» Make 4 sets.  
«37mm Flak» 4 Satz

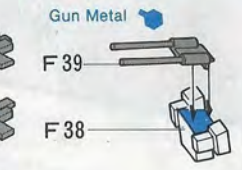

«Deck A»

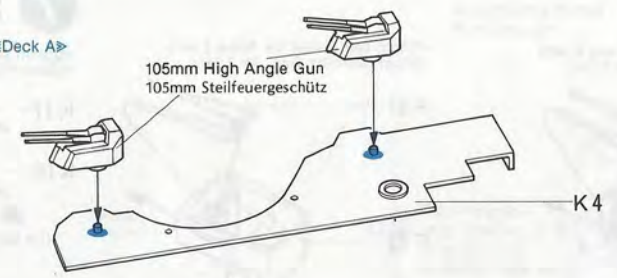

«Deck B»

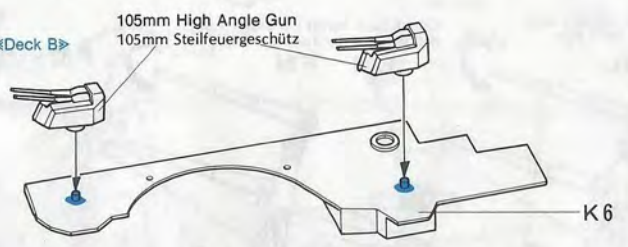

«Deck C»

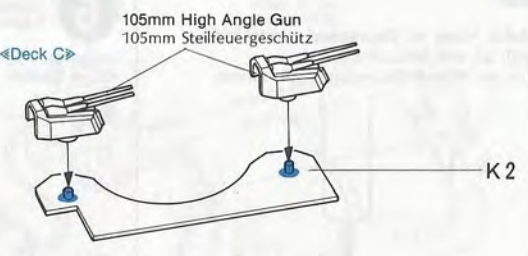

«Deck D»

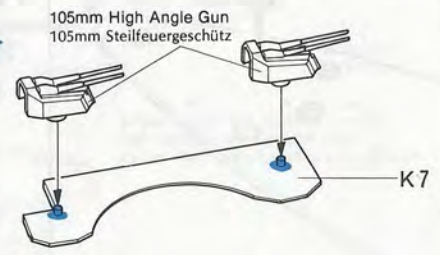

10

### Gun Deck Assembly Kanonen Deck Einbau

«Steam Launch Support»  
«Barkassen Lager»  
Make 2 sets.  
2 Satz

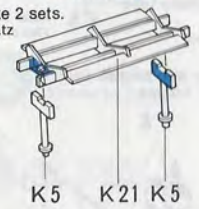

37mm AA Gun  
37mm Flak E 8

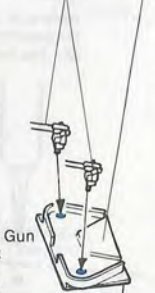

20mm AA Gun  
20mm Flak F 26

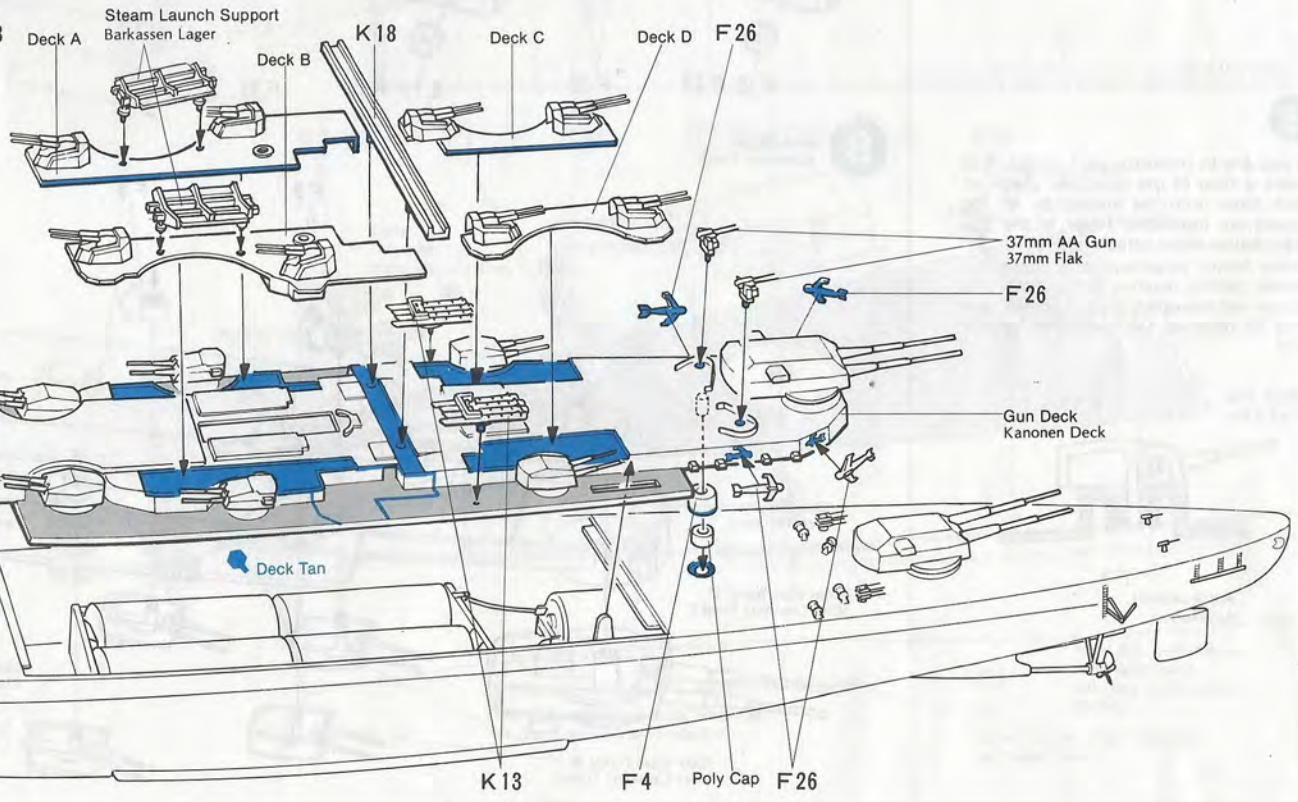
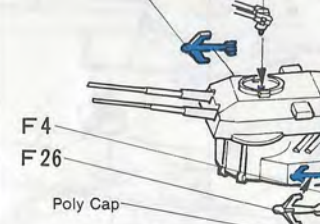

10

Gun Deck is detachable. F4 should be firmly cemented to hull after a poly cap is put in it.  
Kanonen Deck ist abnehmbar. Poly Cap in F4 stecken und F4 gut ankleben.

12



### 11 Bridge A Brücke A

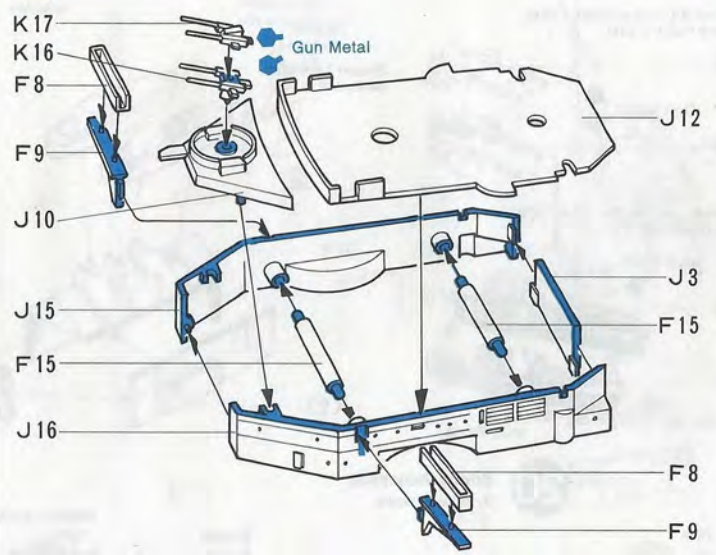

14



### 14 Bridge C Brücke C

«Search Light»  
«Scheinwerfer»

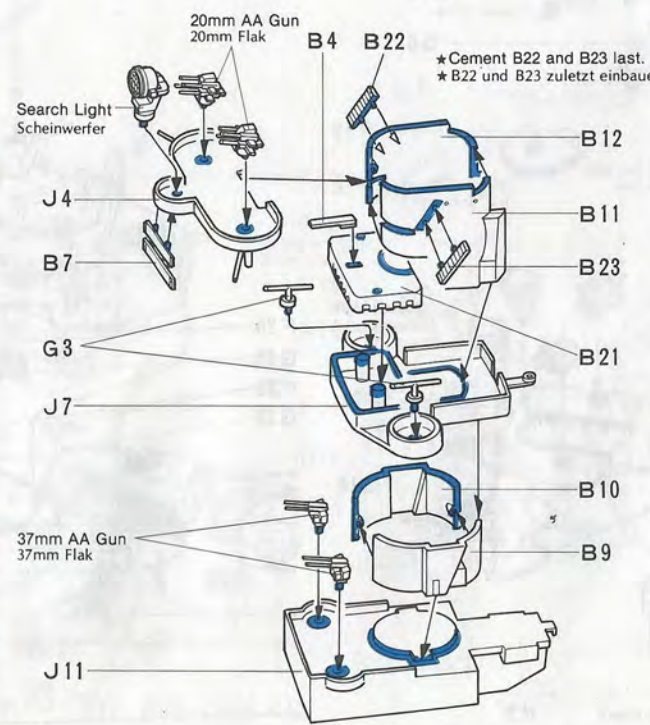
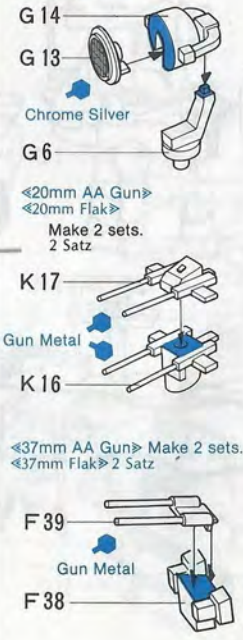

12

### 12 Control Tower Kontroll Turm

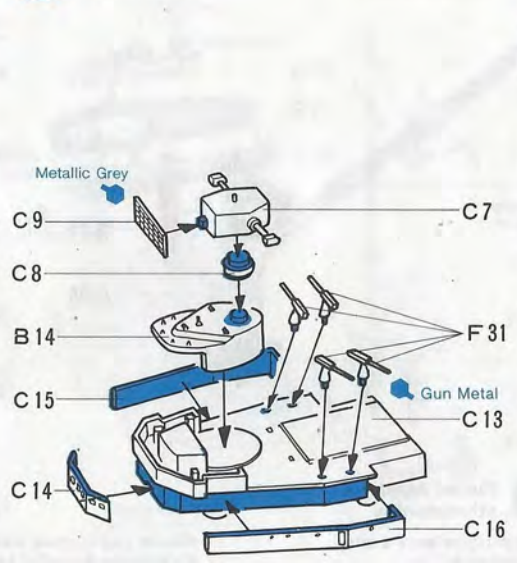

13

### 13 Bridge B Brücke B

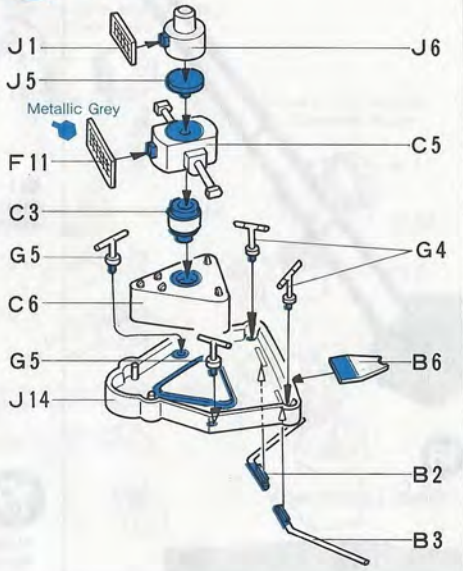

15

### 15 Bridge Assembly Brücke Einbau

«Range Finder» Make 2 sets.  
«Entfernungsmessgerät» 2 Satz

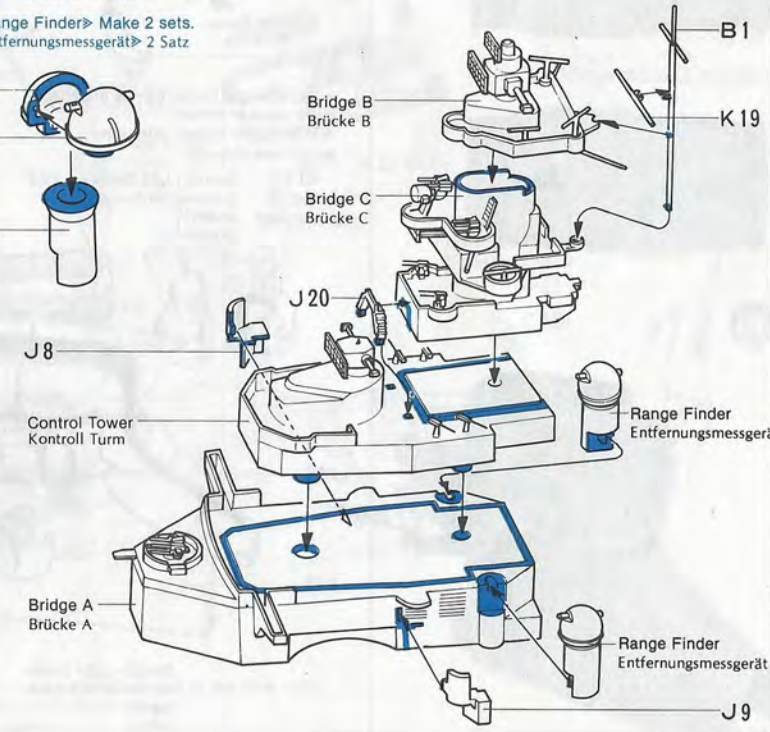
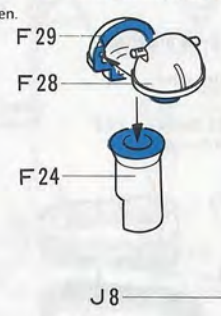

16



**16** Derrick Assembly  
Ladebäumebau

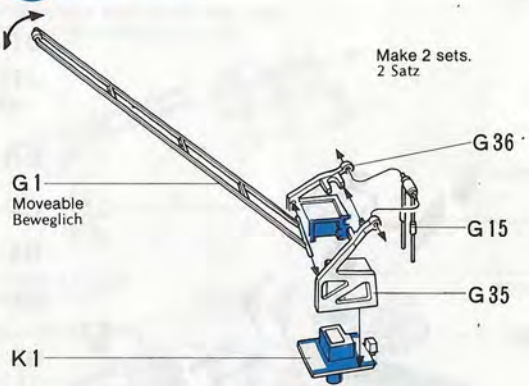

18

«Steam Launch: left»



«Steam Launch: right»



19



**19** Funnel Assembly  
Schornsteinbau



★ Search Light Dome: can be attached either open or closed.  
★ Scheinwerfer Kuppel: offen oder geschlossen einbauen.

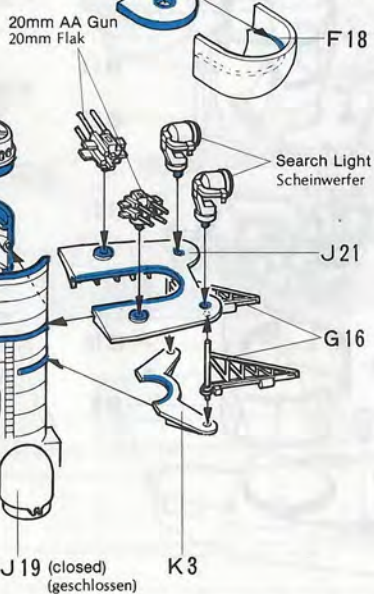
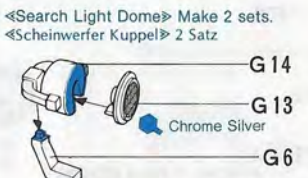
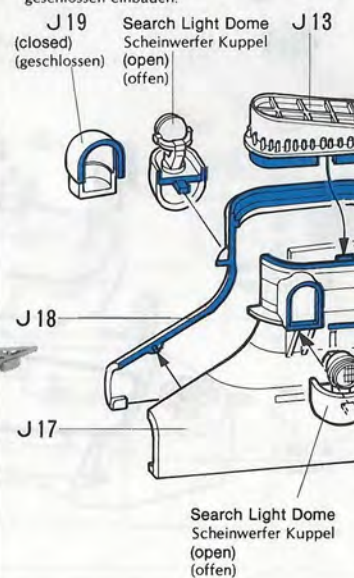

**17** AA Gun and Launch  
Flak und Barkassen

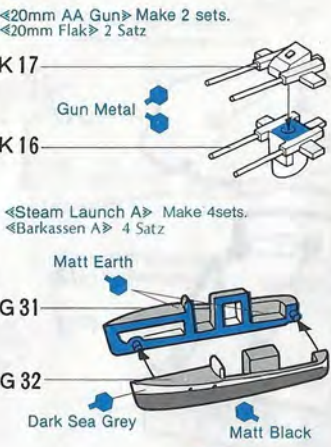

**18** Steam Launch A Assembly  
Barkassen A Einbau

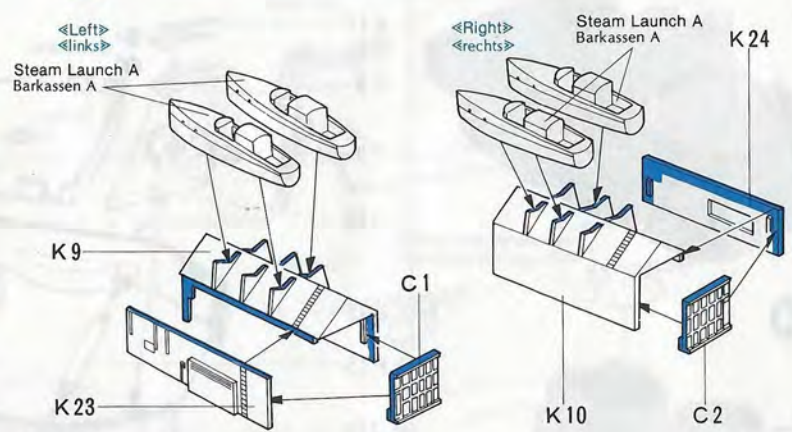

**20** Bridge Assembly  
Brücke Einbau

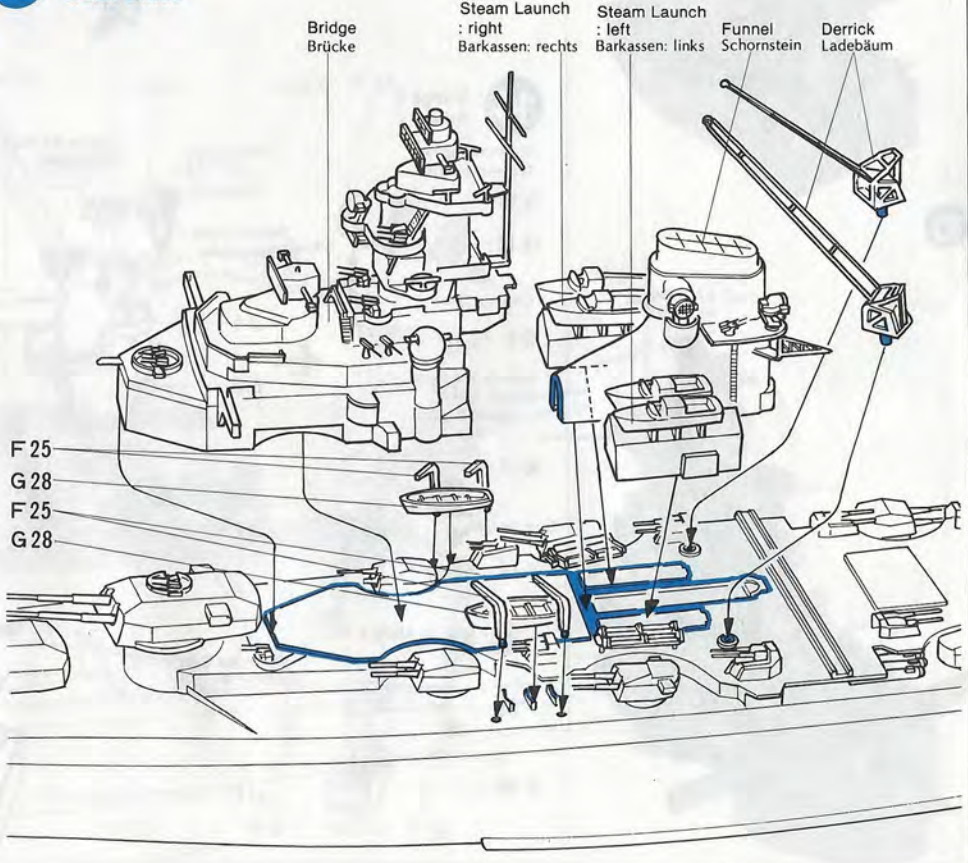



**21**

Attach mast first and then cement D3 and D27 as shown below.  
 Erst Mast einkleben, dann D3 und D27 ankleben.

«Top View»

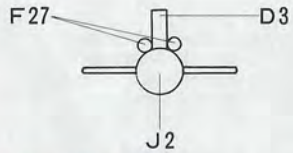

«Front Upper View»

**21**

### Rear Shed Hintere Sched

«Mast»

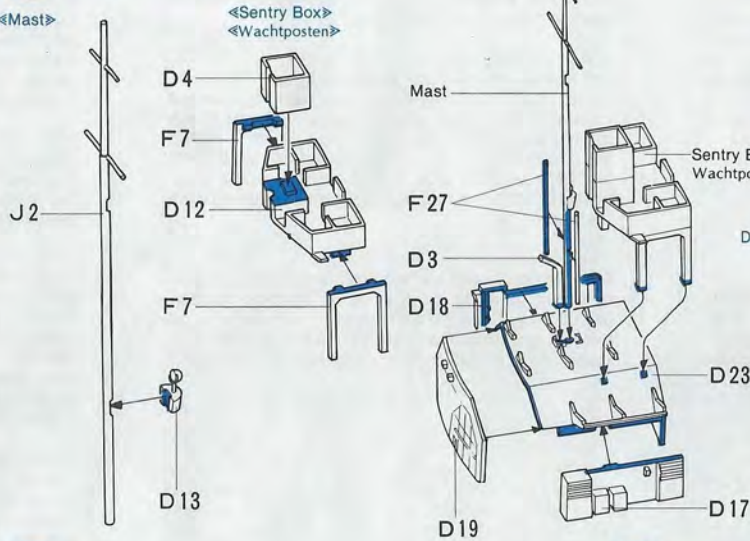
**22**

### Steam Launch B Assembly Barkassen B Assembly

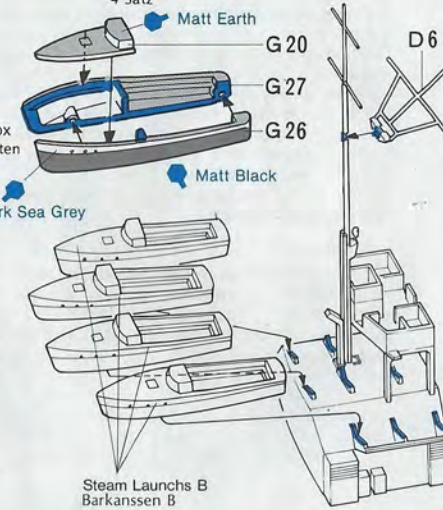
Make 4 sets.  
4 Satz**23**

### Search Light Base and AA Gun Scheinwerfer Basis und Flak

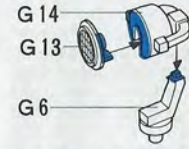
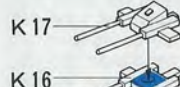
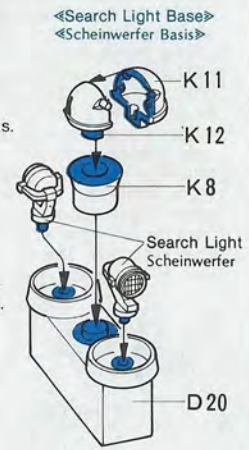
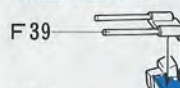
«Search Light» Make 2 sets.  
«Scheinwerfer» 2 Satz«20mm AA Gun» Make 2 sets.  
«20mm Flak» 2 Satz«37mm AA Gun» Make 2 sets.  
«37mm Flak» 2 Satz**24**

### Rear Bridge Hintere Brücke

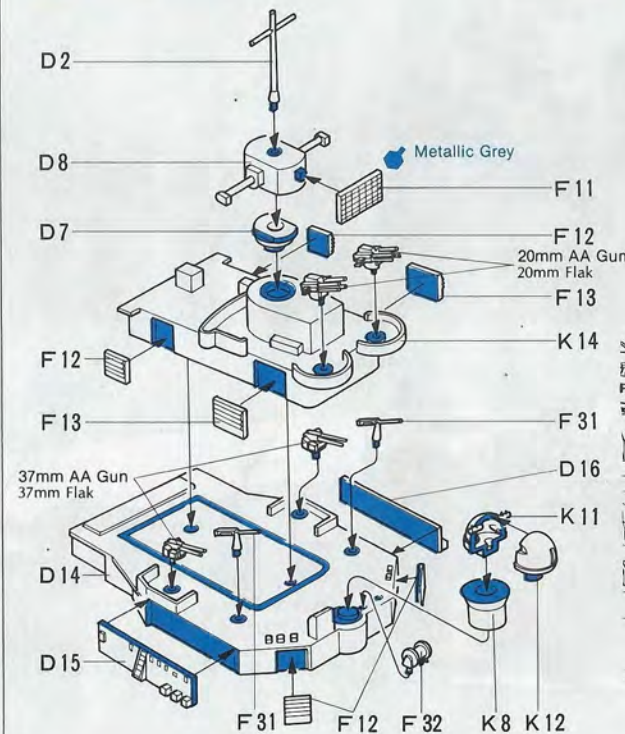
**25**

### Rear Bridge Assembly Hintere Brücke Einbau

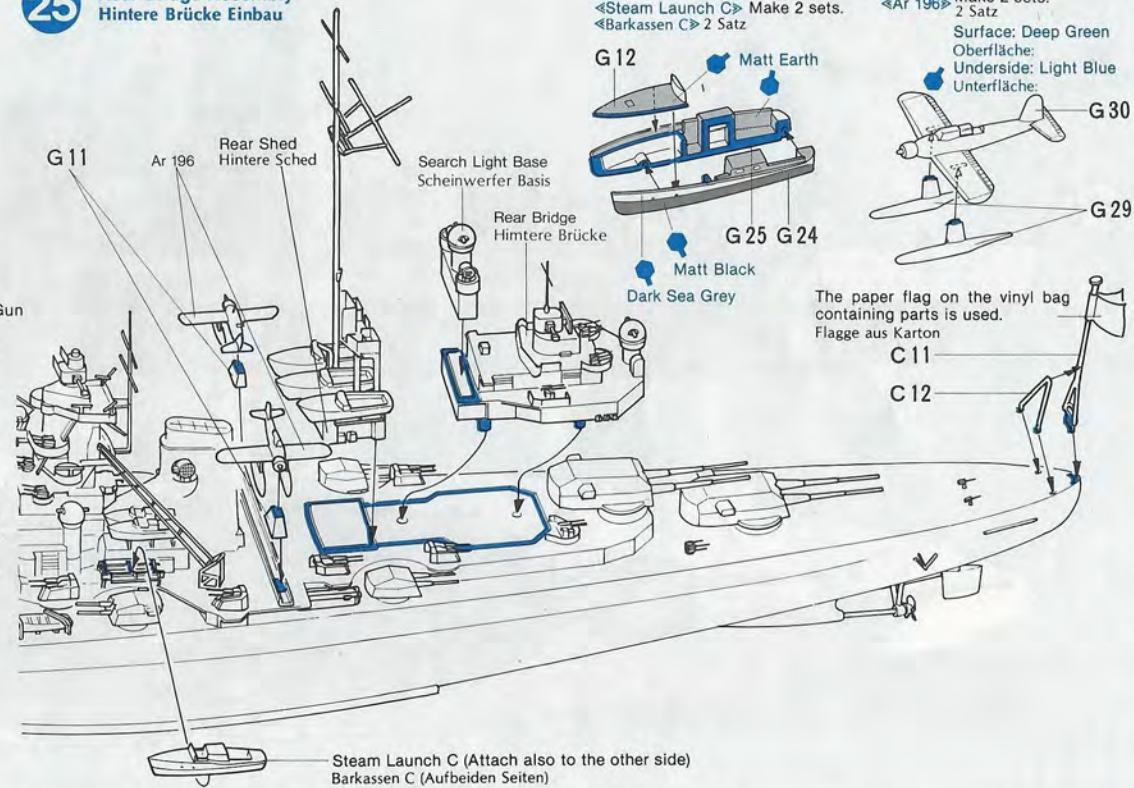

The paper flag on the vinyl bag containing parts is used.  
 Flagge aus Karton

# PAINTING

## «Colour of Tirpitz»

When commissioned for action the Tirpitz was painted an overall dark sea grey. Shortly afterwards she wore the camouflage of three different shades of grey in the usual splinter pattern, while stationed in Germany and Norway. The diagram shows the paint scheme noted between 1943 and 1944. The basic splinter pattern of straight stripes of light and medium sea grey was used throughout. Light grey was used to a certain extent around the 38cm gun turrets, and the lightest grey around the bow and stern. Below the waterline the hull was a lead red color (Black-red). A black line separated the red from the hull grey at the waterline, as in most German warships. The Tirpitz's color scheme at the time of her sinking was an overall dark sea grey.

Camouflage painting shown during 1943~1944.  
Tarnbemalung der Tirpitz am 1943~1944.



Light Grey

Matt White + Dark Sea Grey

Deck Tan

Hull Red

Matt Black

Dark Sea Grey

Deck Tan

## «Bemalung der Tirpitz»

Bei Indienststellung der Tirpitz war diese überall mit dunkelgrauen Tarnstreifen bemalt. Kurz darauf wurde das Schiff mit drei verschiedenen Grautönen getarnt. Das Diagramm zeigt die Bemalung zwischen 1943 und 1944.

Die Splinterstreifen waren von hellgrau bis mittelgrau gehalten.

Hellgrau waren die Plätze um die 38 cm Kanontürme. Das hellste grau hatte der Bug und das Heck. Unter der Wasserlinie war der Rumpf in dunkelrot bemalt. Zwischen dem grau der Aufbauten und des Rumpfes war eine schwarze Linie.

Als die Tirpitz unterging, hatte sie einen einheitlichen dunkelgrauen Anstrich.

## «Painting»

When painting your model, remember to try and be as authentic as possible. 13 basic colours are recommended for your use. If you stick by these colours you will convey the real aura of the actual ship.

## «Bemalung»

Beim Bemalen des Modelles soll man versuchen, so genau wie möglich zu sein. 13 Grundfarben werden benötigt für eine "echte" Tirpitz.

## «Before Painting»

Remove all dust dirt and adhesive smears before attempting any painting. Remember painting does not generally hide bad workmanship. As previously mentioned remove excessive glue or joins with a file, sharp knife or very fine emery cloth. Most parts are best painted after assembly, but some inaccessible parts may be painted before removing from the sprue.

## «Vor dem Malen»

Soll man Staub und Leimreste entfernen. Auch eine gute Bemalung verdeckt nicht schlecht Bauarbeit. Unebenheiten mit Feil oder Flinge entfernen. Viele Teile lassen sich erst nach dem Zusammenbau bemalen, jedoch die kleinen Teile bemalt man am besten am Spritzling.

## «Caution»

If too much paint is applied, it may bubble or run down. In such a case, let it dry for more than an hour, smooth the surface with very fine-grained sandpaper, and then reapply. If dust or waste yarn has stuck to the painted surface, do the same as above. If you paint on a damp day, the surface may become dim or whitish. Wait for a dry day to paint.

## «Versicht»

Das zuviel Farbe aufgetragen wurde, dann kann es Blasen geben oder Tropfen ziehen. In diesem Falle, die Farbe mindestens 1 Stunde trocknen lassen, mit feinem Sandpapier abschleifen und neu bemalen.

## «Painting Implements»

Have the following ready to hand: a flat brush for painting large areas, slender and pointed brushes for painting small parts, trays for mixing paints, sprays etc. After painting, remove paint from the brushes with thinner and wash them in water. Lacquer thinner is cheap and good for washing the brushes, but it must be handled with care because it melts plastic and is very inflammable.

## «Zubehör für die Bemalung»

Flacher Pinsel für grosse flächen, dünner und spitzer Pinsel für klein Teile. Nach Malen den Pinsel mit Verdünner reinigen. Verdünner aber nicht mit Plastik in Verbindung bringen, da sonst Plastik schmilzt.

Dark Sea Grey

Dark Grey

Matt White + Dark Sea Grey

### «Instruction for Using Paint and Solvent»

Paint does not easily adhere to plastic surfaces. This is a property of plastic, it is important to remove dust, finger marks, etc. from the surfaces before they are painted. Solvent should be used in a small quantity. In brushing a large area, move the brush both lengthwise and breadthwise in the same way. Paint must be always kept away from fire.

Farben halten nicht leicht auf Plastik Es ist sehr wichtig, dass Staub, Fingerabdrücke etc. vorher von der Malfläche entfernt werden. Farben nur in Kleinen Mengen verstreichen, grosse Flächen der Länge und auch der Breite nach bemalen. Farben nicht in Nähe offenen Feuers bringen.

### «Colours to be used»

#### «Bemalung»



#### «Dark Sea Grey»

This was the basic colour applied to German ships including the Tirpitz. Grundfarbe deutscher Schiffe

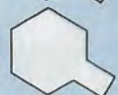

#### «Matt Black»

Apply to the camouflage stripes, waterline, etc. Tarnstreifen, Wasserlinie

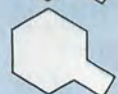

#### «Matt White»

Apply to the camouflage stripes. Tarnstreifen

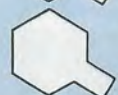

#### «Hull Red»

Apply to the bottom. Rumpf Unterwasserlinie



#### «Light Blue»

Apply to the underside of the planes. Flugzeug Tragfläche Unterseite



#### «Deep Green»

Apply to the topside of the planes. Flugzeug Oberfläche

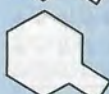

#### «Matt Earth»

Apply to the Steam Launch. Barlassem Oberfläche



#### «Deck Tan»

Apply to wood decks. Holzteile auf dem Deck



#### «Gun Metal»

«Light Grey»  
«Metallic Grey»  
«Gold»  
«Dark Grey»

### «Masking Tape»

Apply the basic paint overall. After it has completely dried, apply masking tape. The tape should be positioned little by little from one end to the other and then press firmly by your fingers. Then, apply another colour. Lastly, remove the masking tape by pulling it toward the newly painted side so that the paint does not come off with it. Work slowly!

### «Abdecken»

Grundfarbe auf die ganze Fläche bringen. Nur wenn die Farbe ganz trocken ist, Abdeckband langsam, Zug um Zug anbringen und mit den Fingern anpressen. Dann andere Farbe auftragen. Auch wieder nur nach volkommenem Trocknen das Abdeckband in Richtung der neuen Farbe langsam abziehen. Darauf achten, dass Farbe nicht abzieht.

### «Weathering»

Express rust to give an air of reality to the model. Use a mixture of matt red, red brown, etc. to show rust caused by sea-water. Dip brush in the mixture, use the brush on a newspaper to remove most of the mixture, and then paint with dry strokes. For your information, rust is often seen along the places where water runs frequently. Recommend you look at photos of fishing boats, tankers, etc.

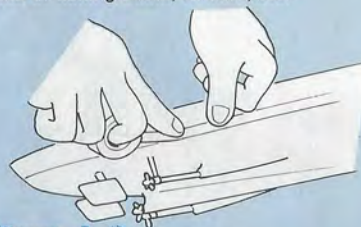

### «Verwitterung – Rost»

Rost gibt mehr Realität dem Modell. Eine Mixtur aus matt red, red brown, etc. zur Malung von Rost- verursacht durch das Meerwasser—verwenden. Pinsel in die Farbe tauchen, auf Zeitungspapier Farbe abtupfen und dann mit trockenen Strichen malen. Rost ist meistens an Stellen, an welchen Wasser ständig Überkommt.

### «Antenna»

The antenna will make your model look better. It should be stretched after the model has been painted. Make slender strings for the antenna as follows. Cut off the runner to a suitable length. Heat it with a candle flame for a while. Then, take it away from the flame and pull it both ways. Stretch the antenna with reference to the drawings, etc. Cut the string a little longer than necessary. Fix it in place by applying adhesive with a match stick. The extra length is cut off after the adhesive has dried.

### «Antennen»

Die Antennen sollten nach dem Bemalen angebracht werden. Die dünnen Fäden können entweder aus Garn, Zwirnfaden oder Plastik hergestellt werden. Aus Plastik gehts so: Spritzlingreste über Kerze unter ständigem Drehen erhitzen und auseinanderziehen. Die Fäden etwas länger lassen, an der Klebestelle wenig Klebstoff anbringen, Fäden ankleben und nach Trocken die Überreste abschneiden. Evtl. Spezialkleber (Schnellkleber) verwenden.



### «Attaching Flag»

The flag is printed on the mouth of a bag containing parts. Cut off carefully and glue it to the Flag staff with the staff in between.

Die Flagge ist auf einen Beutelsverschluss gedruckt, Ausschneiden und an Fahnenmast kleben.

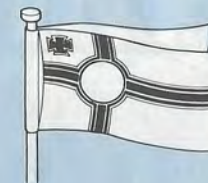

Camouflage painting shown around the middle of 1942. Tarnbemalung mittel 1942.



Dark Sea Grey



Dark Grey

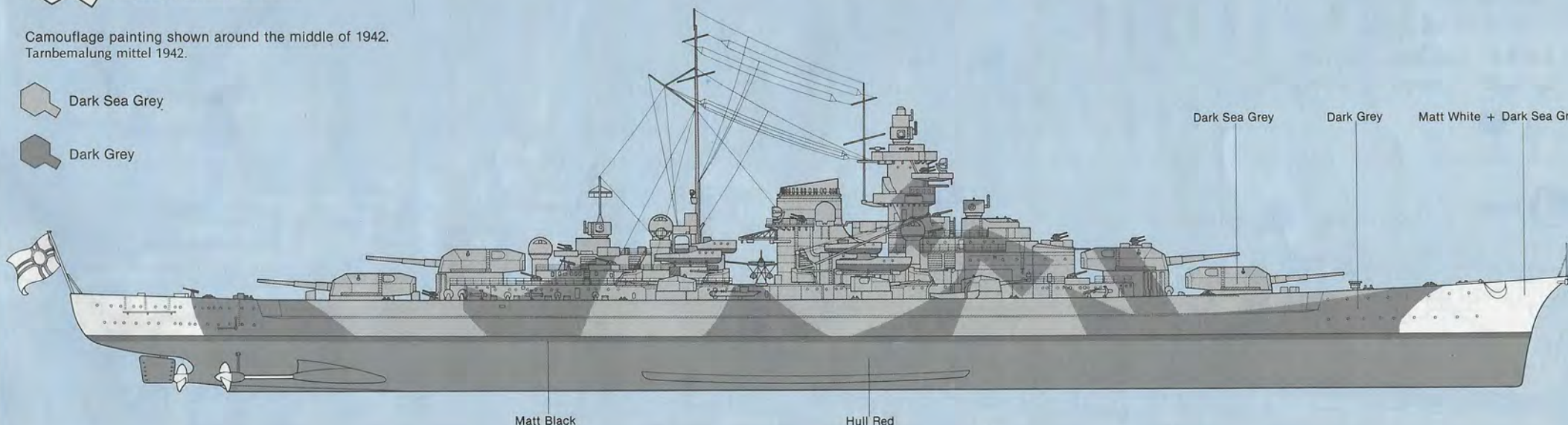

# PARTS

## B Parts

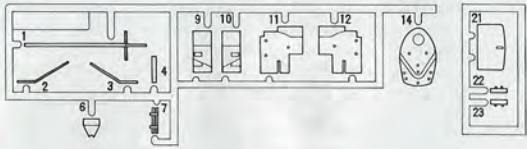

## F Parts (2 pcs.)

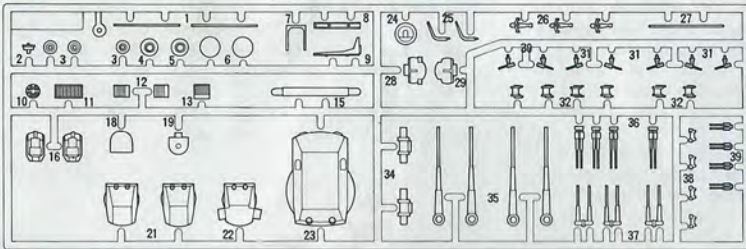

## G Parts (2 pcs.)

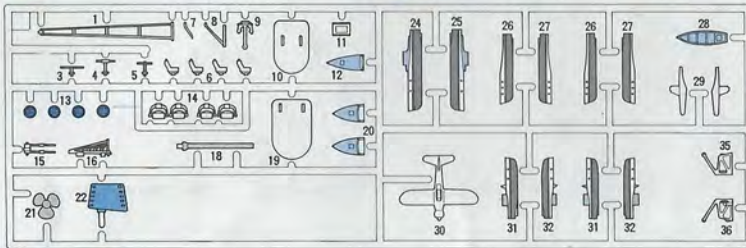

## J Parts

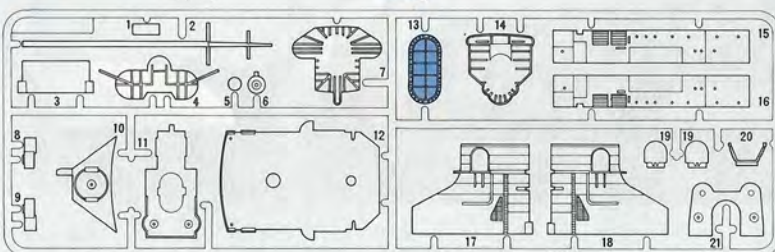

## K Parts

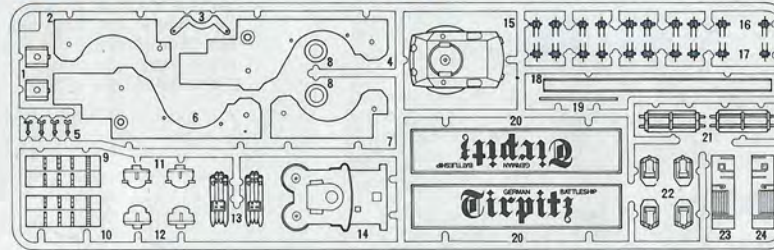

## E Parts

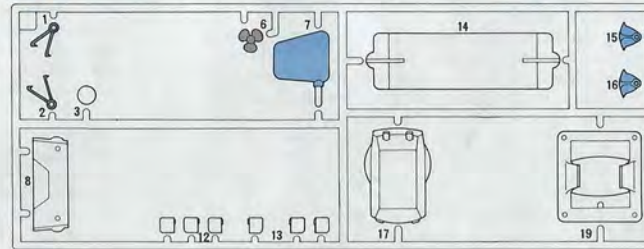

## D Parts

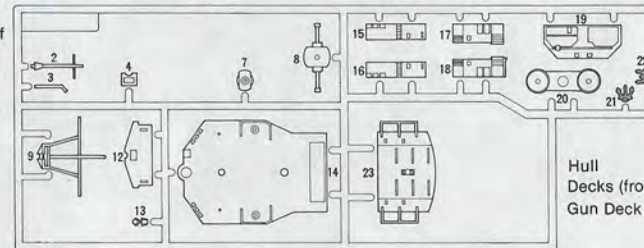

## M Parts

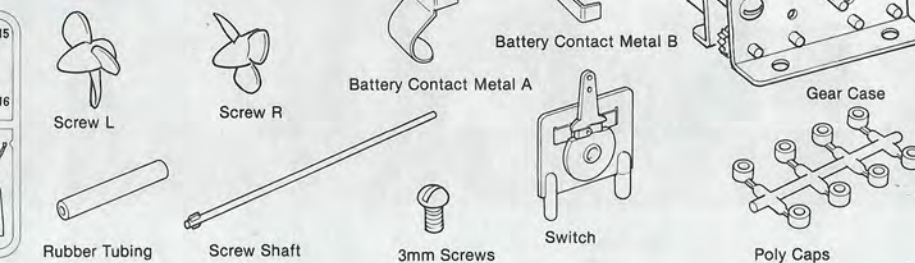

## A Parts (2 pcs.)



## C Parts

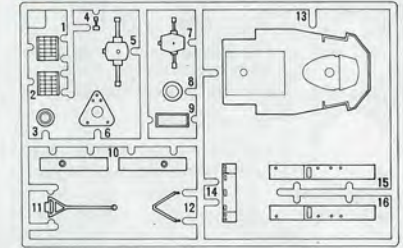

BUILD A COLLECTION OF TAMIYA  
PRECISION SHIP MODELS

1/350 GERMAN BATTLE  
SHIP BISMARCK



1/72 JAPAN TORPEDO BOAT PT-15



1/700 JUNYO AIRCRAFT CARRIER



**TAMIYA**  
TAMIYA PLASTIC MODEL CO.  
3-7 ONDWARA, SHIZUOKA-CITY, JAPAN