

TBF-1 AVENGER

1/72 scale

Although the Grumman TBF Avenger torpedo bomber had only made its first flight on August 1, 1941, it was available in sufficient numbers by the outbreak of World War Two to become a major factor in that war.

One of the primary factors in the success of the Avenger was its ability to carry a full-size submarine torpedo. This required a large weapons bay which could also be used to haul up to 2,000 lbs of bombs or other weapons, whereas earlier torpedo bombers could carry little more than half that amount. The Avenger also was equipped with far more defensive armament than any other carrier-based dive or torpedo bomber. The most apparent was the power turret located behind the cockpit green house. Additional armament was located in the cowling and the lower turret notch. This latter position sometimes gave the Japanese pilots a shock when they mistook the bombers for fighters and approached them from below, only to come face to face

with a live machine gun.

Nearly 10,000 of the big torpedo bombers were built by Grumman and General Motors' Eastern Aircraft Division. The GM-built models were designated TBM. Many of the TBMs were delivered to the Royal New Zealand Air Force and Great Britain's Royal Navy. Later versions of the Avenger were capable of carrying rockets and radar.

The end of the War did not bring an end to the Avenger's usefulness. Some were fitted with huge belly-mounted radar tubs for anti-submarine search; a few were modified into passenger transports for seven people for carrier shuttle flights, and eventually some found their way into the aerial fire fighting service.

Though large, with a 54 foot wingspan, the Avenger had a top speed of 278 mph. With a full weapon load the TBF had a range of over 1,200 miles. Power was provided by a 1,700 hp Wright Cyclone engine.

Minicraft Models, Inc.
1510 W. 228th St.
Torrance, Calif. 90501

1651

ACADEMY
아카데미
MINICRAFT



Cement Parts
Coller
Kleben
Pegar
Incollare
Colar
Kleven



DO NOT cement
Ne pas coller
Nicht kleben
No pegar
Non incollare
Nao colar
Niet kleven



Cut away
Couper
Scheiden
Cortar
Tagliare
Cortar
Snijden



Optional parts
Choix
Auswahlmöglichkeit
Eleccion
Scelta
Opcao
Keuze



3

Repeat operation
Répéter l'opération
Vorgang wiederholen
Repitir la operacion
Ripetere
Repitir a operação
Herhalen

1

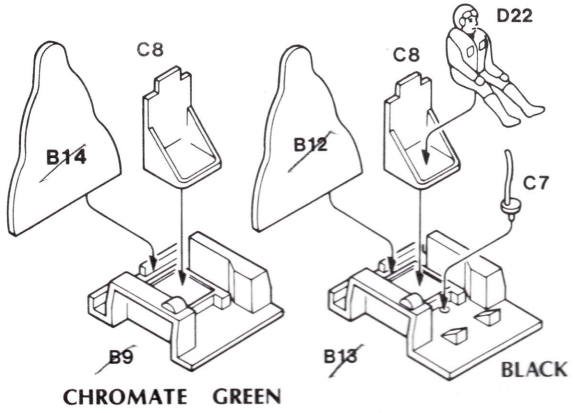

2

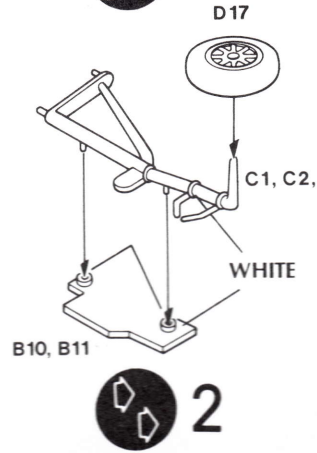

3

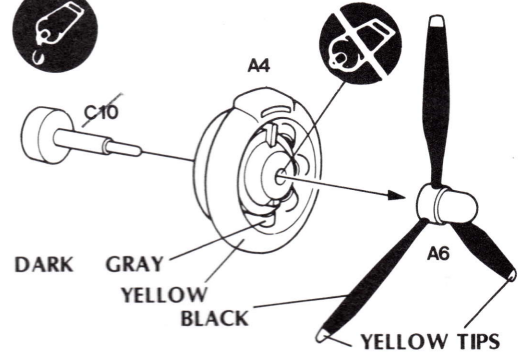

4

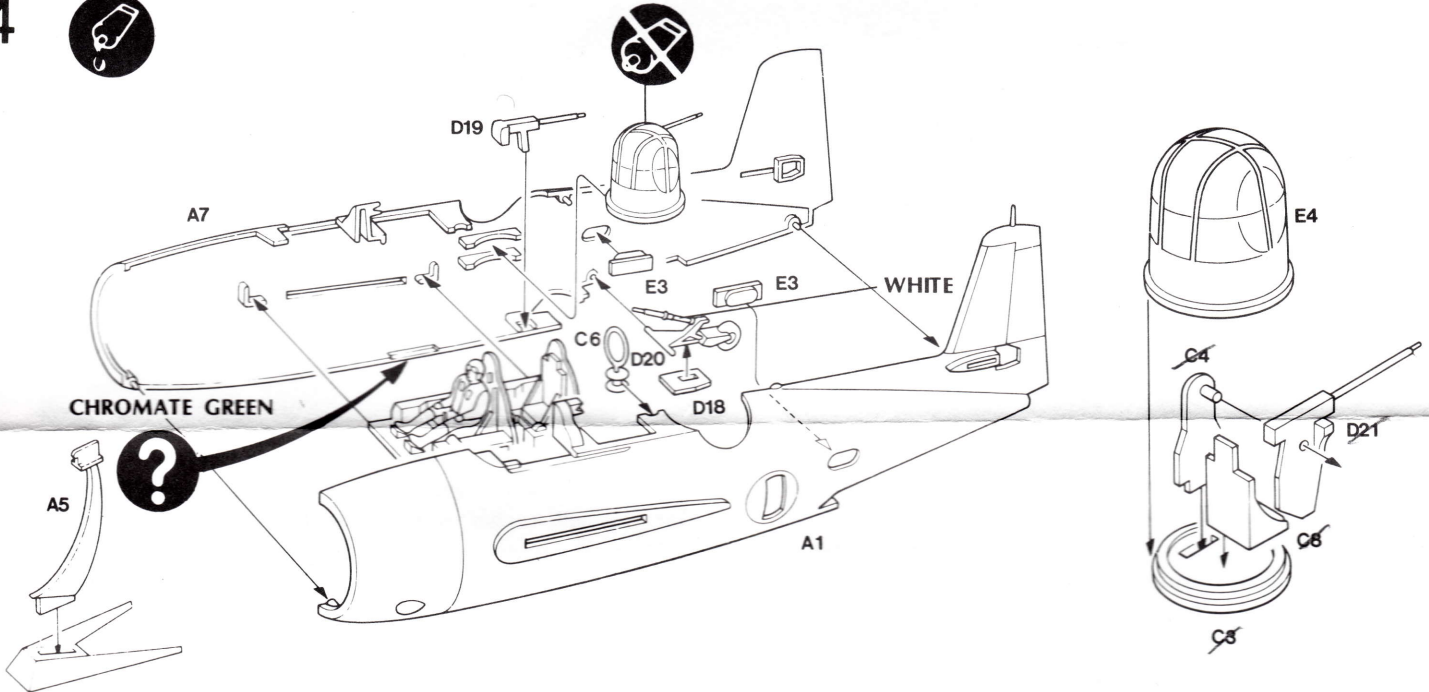

5

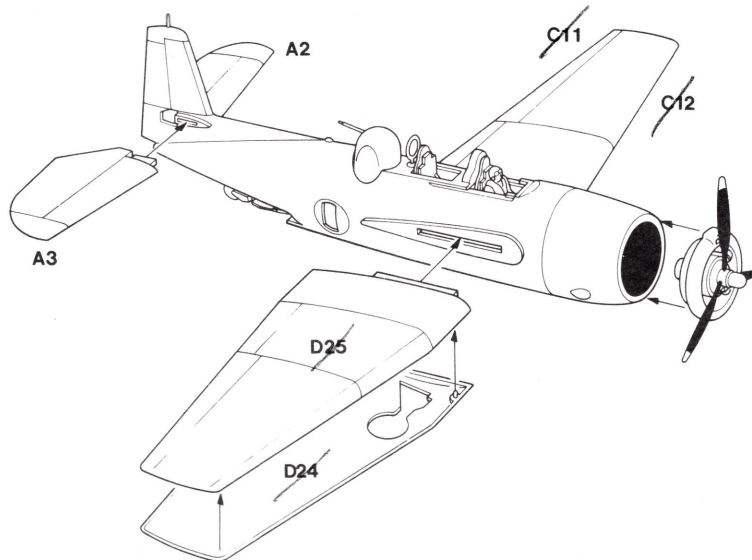

6

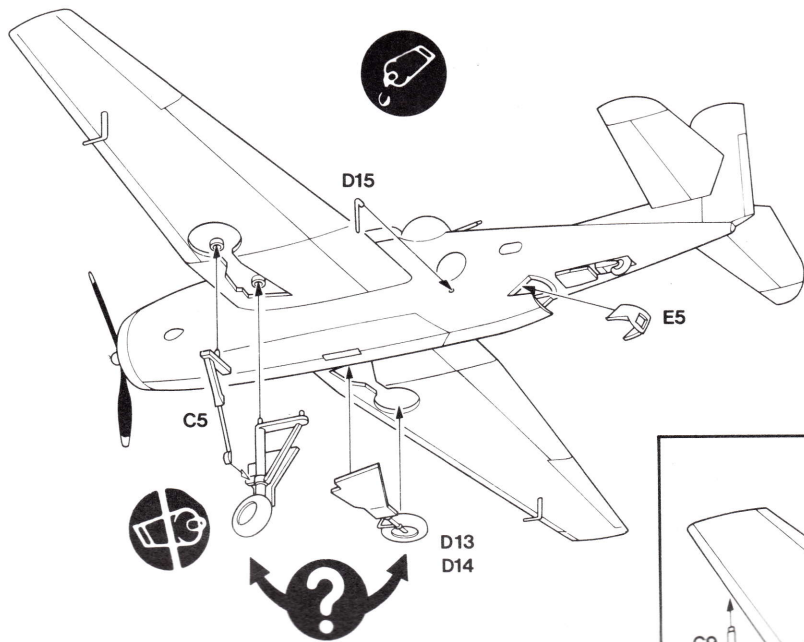

7

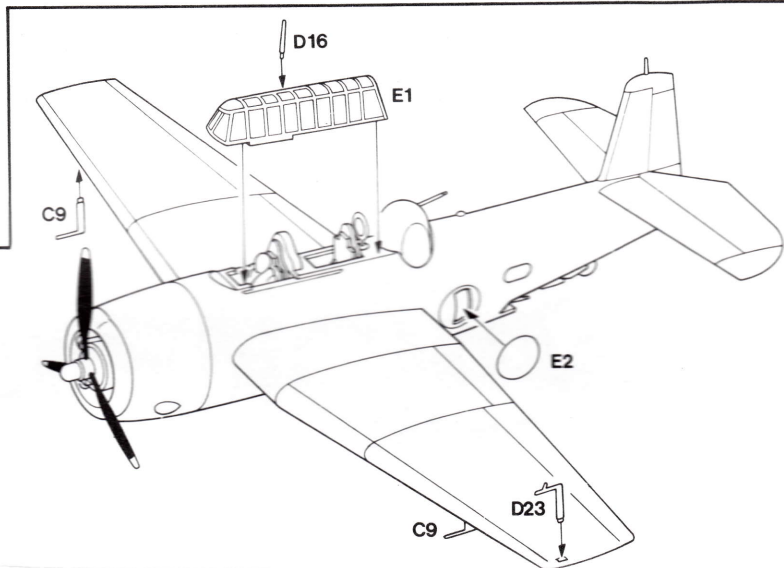

ALL COLORS ARE FLAT FINISH.

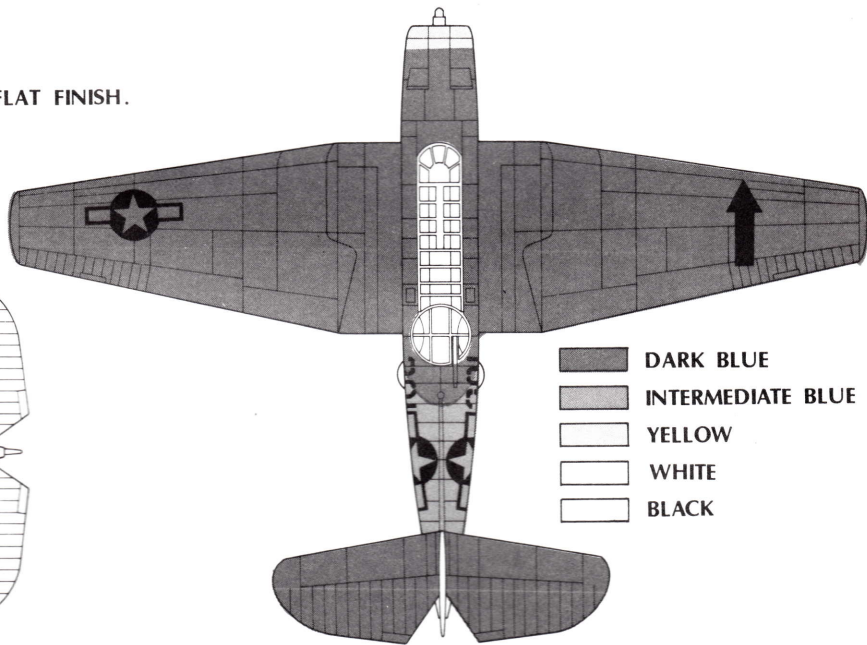
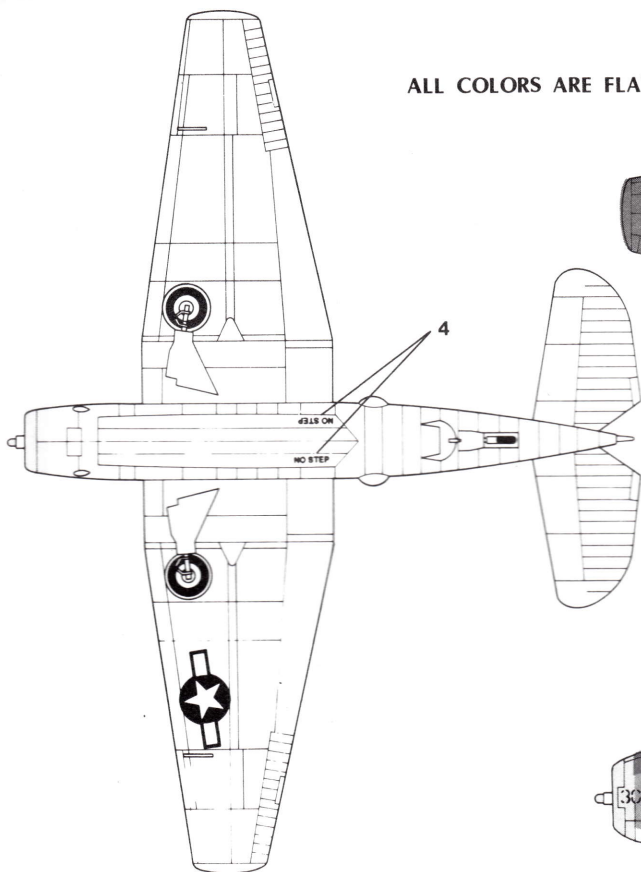

- DARK BLUE
- INTERMEDIATE BLUE
- YELLOW
- WHITE
- BLACK

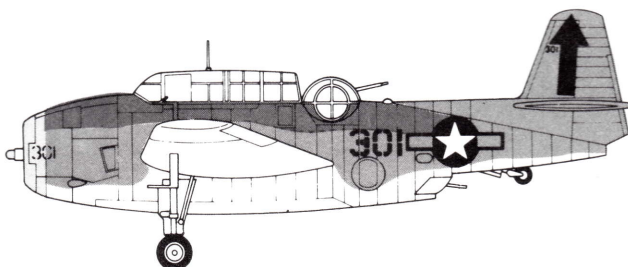

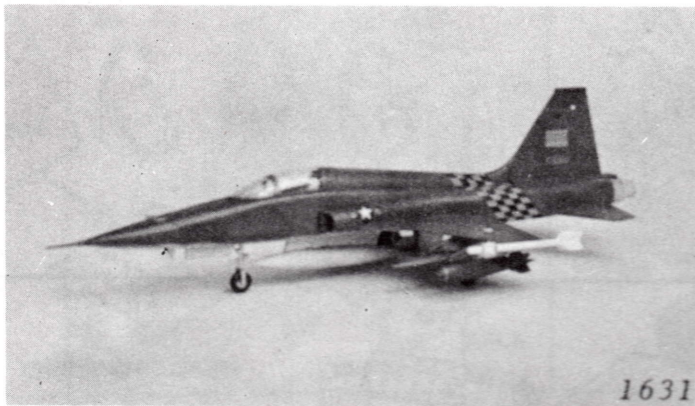

1631

1/48 F-5A NORTHROP FREEDOM FIGHTER



1632

1/48 NORTHROP F-5B FREEDOM FIGHTER



1623

1/72 SPAD XIII WW I FIGHTER

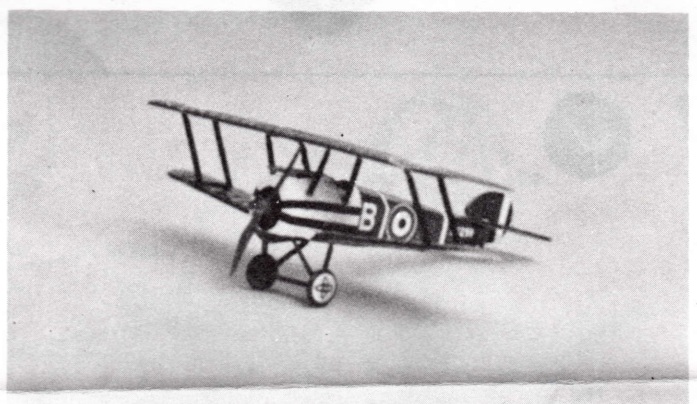

1624

1/72 SOPWITH CAMEL WW I FIGHTER



1633

1/72 F-5A NORTHROP FREEDOM FIGHTER



1620

1/72 YF-16 FIGHTING FALCON

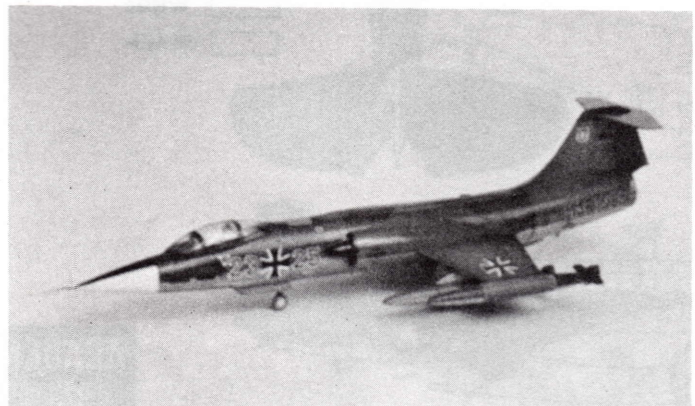

1619

1/72 LOCKHEED F-104G STARFIGHTER

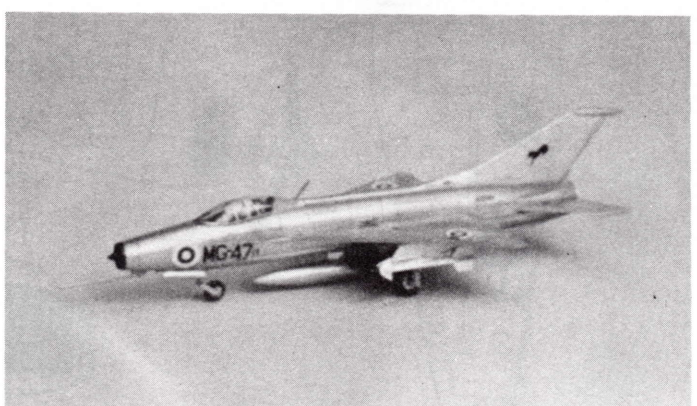

1618

1/72 MIG-21 FISHBED