

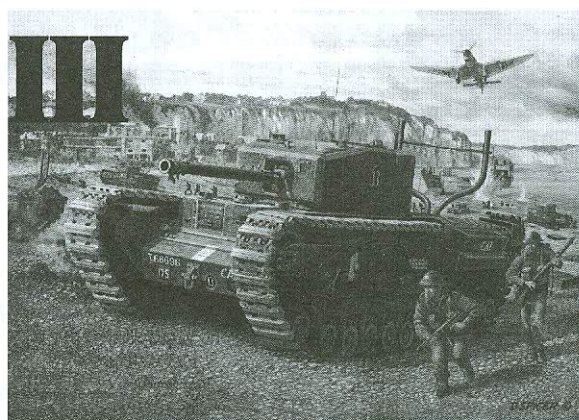

Churchill Mk III

Dieppe Raid



**SPECIAL THANKS: Ossie Orsbourm

1942 was a tough year for the Allied. The Red Army finally stopped the Wehrmacht's attacks just barely therefore Joseph Stalin himself demanded that the Allies create a second front in France to force the Germans to remove some of the pressure on the Red Army. Winston Churchill considered the Allied were still in lack of sufficient amphibious warfare capability, therefore should concentrate forces in the North Africa to prevent the Germans from Middle Asia. Yet to reassure Stalin, also to gather amphibious warfare experience, Operation Jubilee was launched, with was an attack on the German-occupied port of Dieppe, and land component was predominantly the 2nd Canadian Infantry Division.

Dieppe, a coastal town in northern France, is built along a long cliff that overlooks the English Channel. This town is within operating range of the RAF, with a population less than 30,000. By 1942 it was defended by the German 302nd Static Infantry Division, comprised artillery, engineer and anti-tank units.

The initial landings began at 04:50 on 19 August, under cover of the RAF and Royal Navy, more than 6,000 troops landed on French coasts around Dieppe, among them the 14th Canadian Armoured Regiment was the main force to attack the town. There were only 29 Churchill tanks finally landed, 2 of them sank in the sea, and 12 more became bogged down in the soft shingle beach. The rest of 15 managed crossed the seawall, yet were confronted by a series of tank obstacles that prevented their entry into the town. There were ordered retreated back to the coast and offered firepower to infantry. Most Churchill tank crews were forced to surrender after out of ammunition. Although the Dieppe Raid as considered as a failure, yet the experience later influenced preparations for the North African and Normandy landings. Dieppe was finally liberated by the 2nd Canadian Infantry Division on the 1st September, 1944.

1942年、第二次大戦は、ドイツ軍の猛攻を受けたソビエト軍が、厳しい冬の気候に助けられてかろうじて戦線を維持するといった状況であった。ソビエト軍としては、米英政府に対し、西ヨーロッパへの上陸作戦を実施し、東部戦線でのドイツ軍による圧力を軽減させることを期待していた。しかし、英首相チャーチルは、米英軍には大規模な上陸作戦を実施する能力はまだ無いと認識しており、それよりも北アフリカに戦力を集中し、ドイツ軍の中央アジア進出を阻止することが最善の策と考えていた。だが、ソビエト軍がドイツ軍に降伏する恐れや、スターリンに対する配慮から、チャーチル首相は、小規模な上陸作戦をディエップで実施することを決意したのである。上陸部隊の主力は、カナダ第2歩兵師団が務めた。この作戦は、連合軍にとって上陸作戦の実戦経験を得るというだけでなく、LST(戦車揚陸艦)やチャーチル戦車といった新兵器の実戦テストといった意味合いを持っていたのである。

ディエップは、英仏海峡に面した、人口3万人ほどの北フランスの港町である。そこは、英空軍機の行動範囲にあり、フランス降伏後は、ドイツ軍に占領され、砲兵大隊、工兵大隊、対戦車大隊を擁する第302歩兵師団が守備隊として駐屯していた。

1942年8月19日夜明け、空軍と海軍に掩護された6000名の部隊が、幅20kmにわたってディエップの海岸に上陸を開始した。上陸部隊は、3つに編成され、その中のカナダ第14戦車連隊は、主力部隊であり、合計29輦のチャーチル戦車が海岸に送り込まれた。2輦がLSTから発進する際に海没し、上陸に成功した他のチャーチル戦車も困難な状況に直面することとなる。硬い小石が敷き詰められた海岸では、戦車は簡単にスタックし、12輦が動けなくなり、固定砲台と化した。他の15輦は海岸線を横断、ドイツ軍防衛線まで達し、多くの掩体壕を破壊した。しかし、セメント製の障害物を突破することはかなわず、海岸まで後退し、LSTに撤退する歩兵を掩護するという命令が下った。ほとんどのチャーチル戦車乗員は、弾薬が尽きるまで戦い、そして降伏した。上陸作戦は失敗に終わったものの、この戦いはノルマンディ上陸「オーバーロード作戦」のための多くの貴重な経験をもたらした。そして、カナダ第2歩兵師団は、1944年9月1日までに再度ディエップに到達し、その町を開放することに成功したのである。

二次大戰進入1942年，蘇聯在經歷了一場嚴冬之後，勉強的在德軍面前穩住陣腳，迫切的希望英美聯軍能在西歐開闢第二戰場，來緩解德軍直接帶給蘇軍的強大壓力。英國首相邱吉爾卻認為此時英美聯軍尚無大規模的登陸能力，應該將力量集中運用於北非，阻止德軍進入中亞地區。但為了安撫史達林，避免蘇聯與德國片面講和。同時汲取登陸作戰所必須的經驗，測試戰車登陸艇與邱吉爾戰車等武器的實戰性能。於是加拿大第二步兵師為主力的盟軍部隊，選擇1942年8月在法國的迪耶普實施了一次行動代號為“銀禧”的登陸作戰，又被稱做“突襲迪耶普”。

迪耶普是一座位於法國北部，臨英吉利海峽的港口都市，此地位於皇家空軍戰鬥機的航程之內，人口尚不及三萬。法國被佔領後此地由德軍第302靜態步兵師負責防務，該單位擁有砲兵營、工兵營以及反戰車營等納入其編裝。

1942年8月19日凌晨，六千多名地面部隊在海空軍的掩護下，於迪耶普鎮周邊二十公里範圍的海岸登陸。其中由第十四裝甲團做為攻擊迪耶普鎮的主力，登陸的三個梯隊共計29輛邱吉爾戰車，其中兩輛由登陸艇駛出時不慎沉入海中，成功登岸的邱吉爾戰車又面臨深陷在由堅硬卵石構成的礫灘之中，其中12輛因此滯留在海灘之上成為固定的碉堡，另外15輛越過海灘繼續深入，摧毀了多處德軍掩體，但無法通過耶普鎮鎮上預先設置的混凝土路障而奉命折返海灘，為朝登陸艇撤退的步兵提供掩護，多數邱吉爾戰車乘員在射擊完所有彈藥之後繳械被俘。迪耶普登陸雖然以失敗告終，但為日後的諾曼地登陸提供了寶貴的經驗，到了1944年9月1日，加拿大第二步兵師終於又再次的進入並解放了迪耶普鎮。

Illustration: 圖示說明



Method For Applying Decals:

1. Clean Model Surface With Wet Cloth.
2. Cut Out Of Decal Sheet And Dip Them In Warm Water For 15 Seconds.
3. Place it on proper position on model.
4. Slide off base paper leaving decals On Model With Wet Finger Tip.
5. Move Decals To Exact Position, Push Out Excess Water Under Decal With Soft Cotton Cloth.
6. When Decals Get Dry Then Complete.

水貼紙使用說明:

1. 將模型表面擦乾淨
2. 將貼紙剪下泡入溫水中浸泡約15秒
3. 將泡濕之貼紙取出置於欲貼處旁
4. 用指尖輕推貼紙表面使其滑出底紙
5. 將貼紙調整至適當位置並輕擦拭水份
6. 待其自然乾燥後即完成

Color list: 塗料表

Color	Brand	Gunze Sangyo			Humbrol	Revell	Lifecolor
		Hobby Color	Mr.Color	Mr.Color Spray			
Black	黑	H2	C2	J2	21	7	LC52
Brass	黃銅	H9	C9	J9	54	92	LC75
Flat white	消光白	H11	C62	J62	34	05	LC01
Khaki	卡其	H81	C55		72		UA39
German gray	德國灰	H32	C40	J40	92	79	UA073
Red brown	紅褐	H47	C41	J41	160	383	
Steel	黑鐵	H18	C28	J28	53	91	LC76
Tire black	輪胎黑	H77	C33+C62		85	302	LC02
Wood brown	木棕	H37	C43		169		FS12

Churchill Infantry Tank

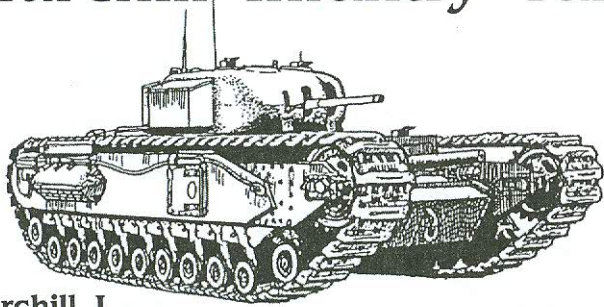

Churchill I
2-pdr gun x 1
3 inch howitzer x 1

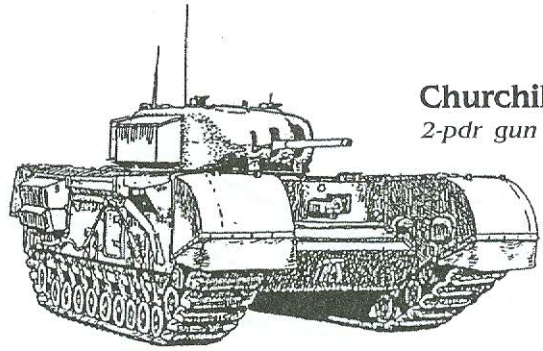

Churchill II
2-pdr gun x 1

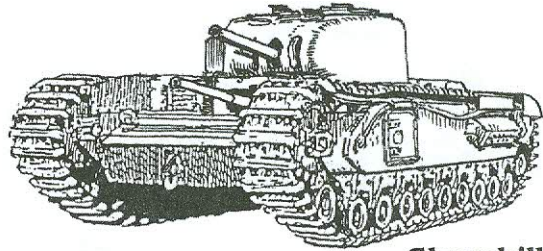

Churchill II CS
3 inch howitzer x 1
2-pdr gun x 1

**3 inch howitzer in turret, 2-pdr in hull. Few built.

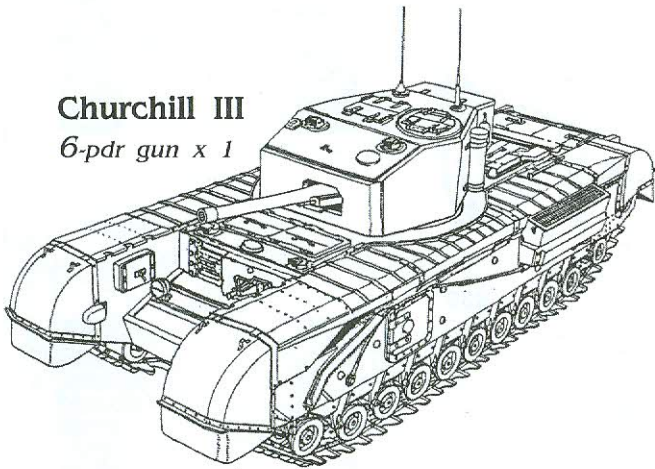

Churchill III
6-pdr gun x 1

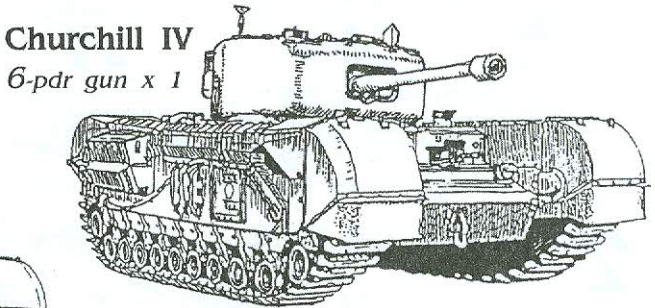

Churchill IV
6-pdr gun x 1

Box Section Spudded

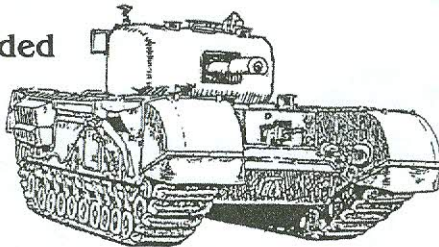
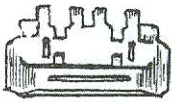

Churchill V
95mm howitzer x 1



Webbed & Studded

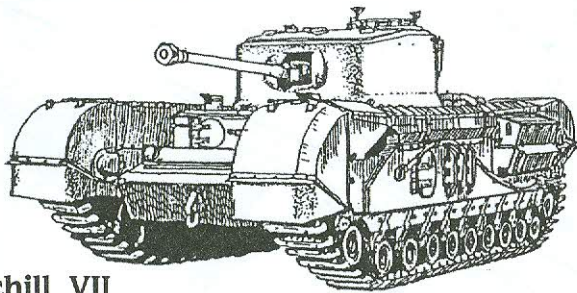

Churchill VII
75mm gun x 1

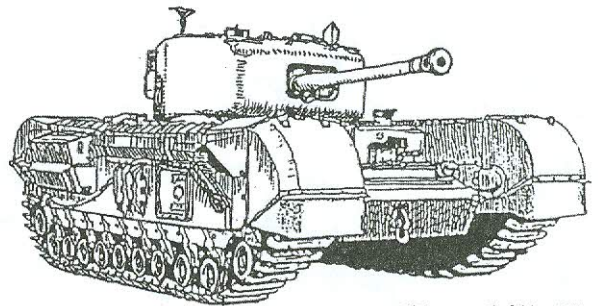

Churchill VI
75mm gun x 1

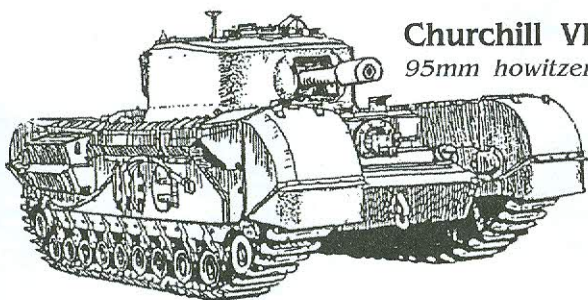

Churchill VIII
95mm howitzer x 1

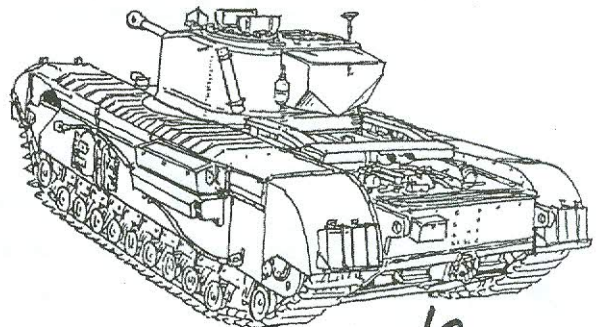

Shin. Ueda

上田 信

1

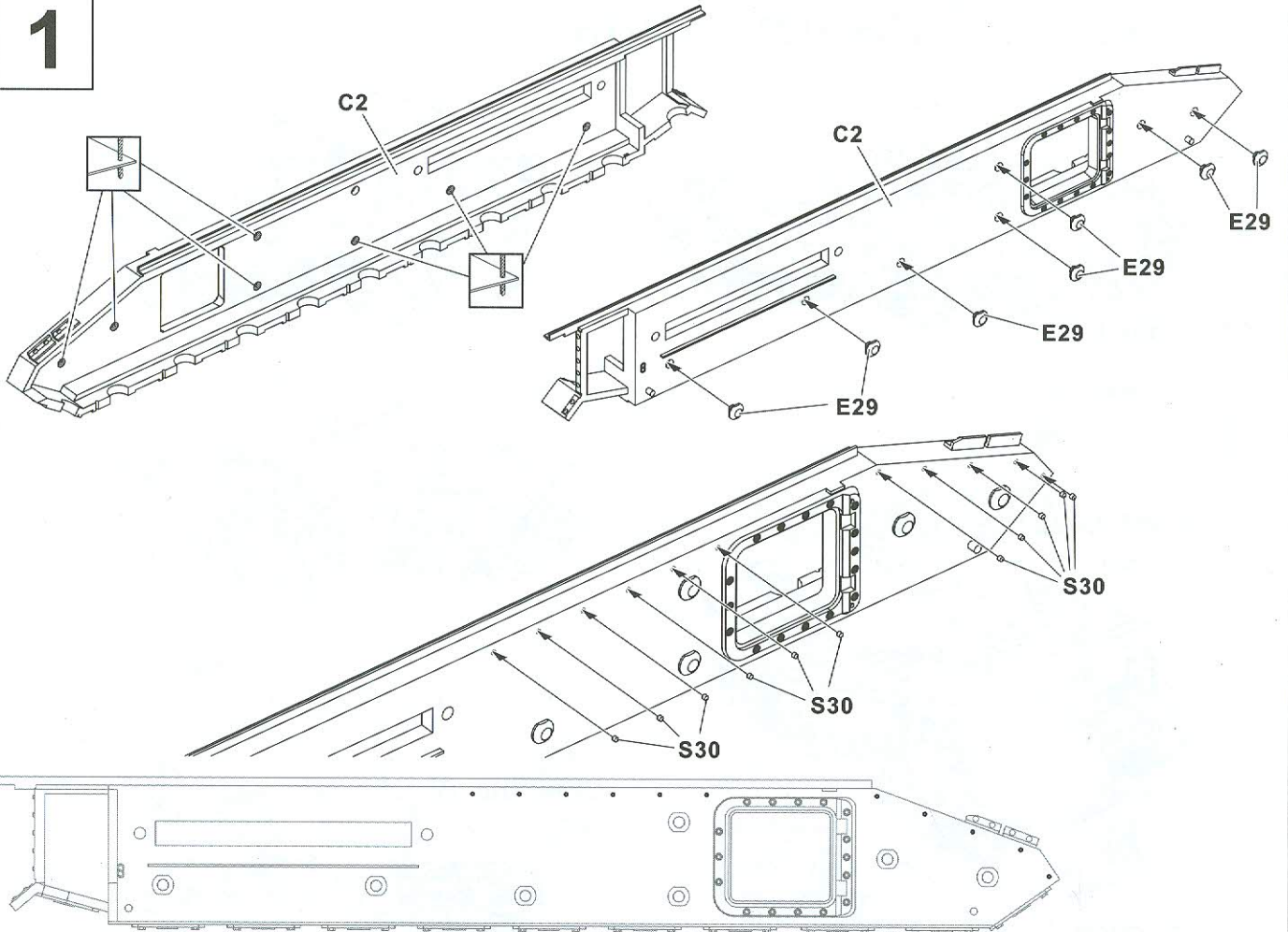

2

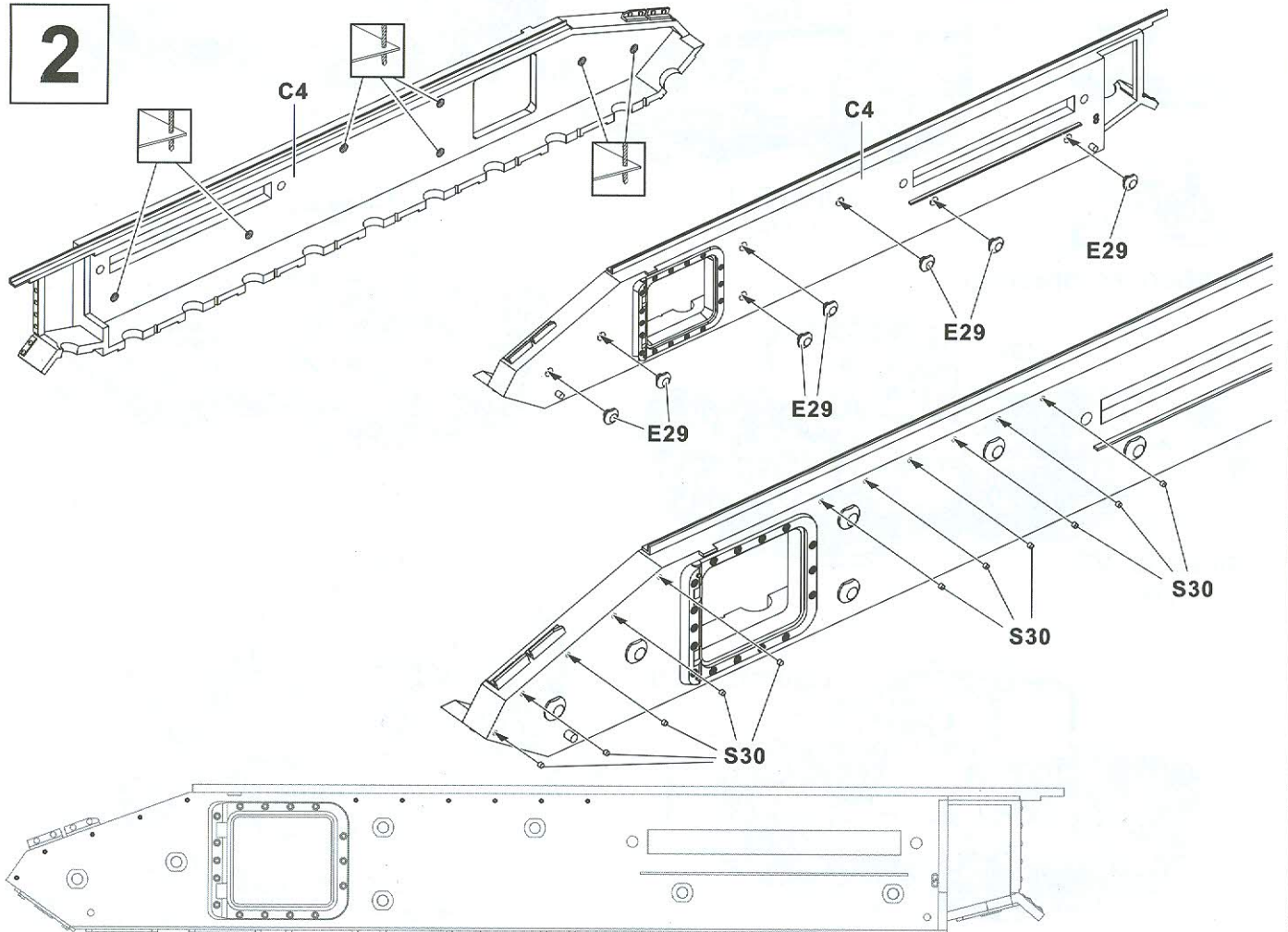

3

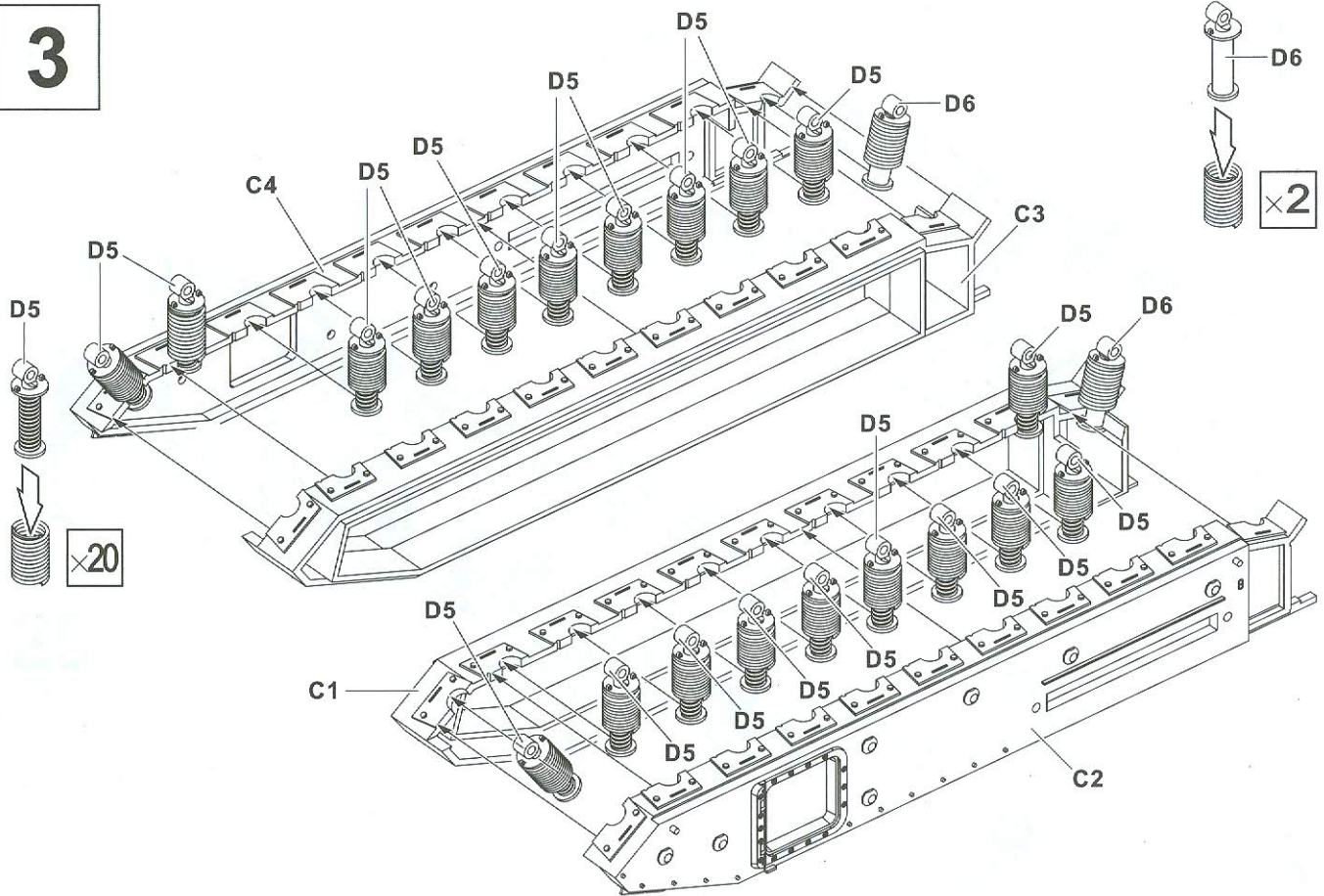

4

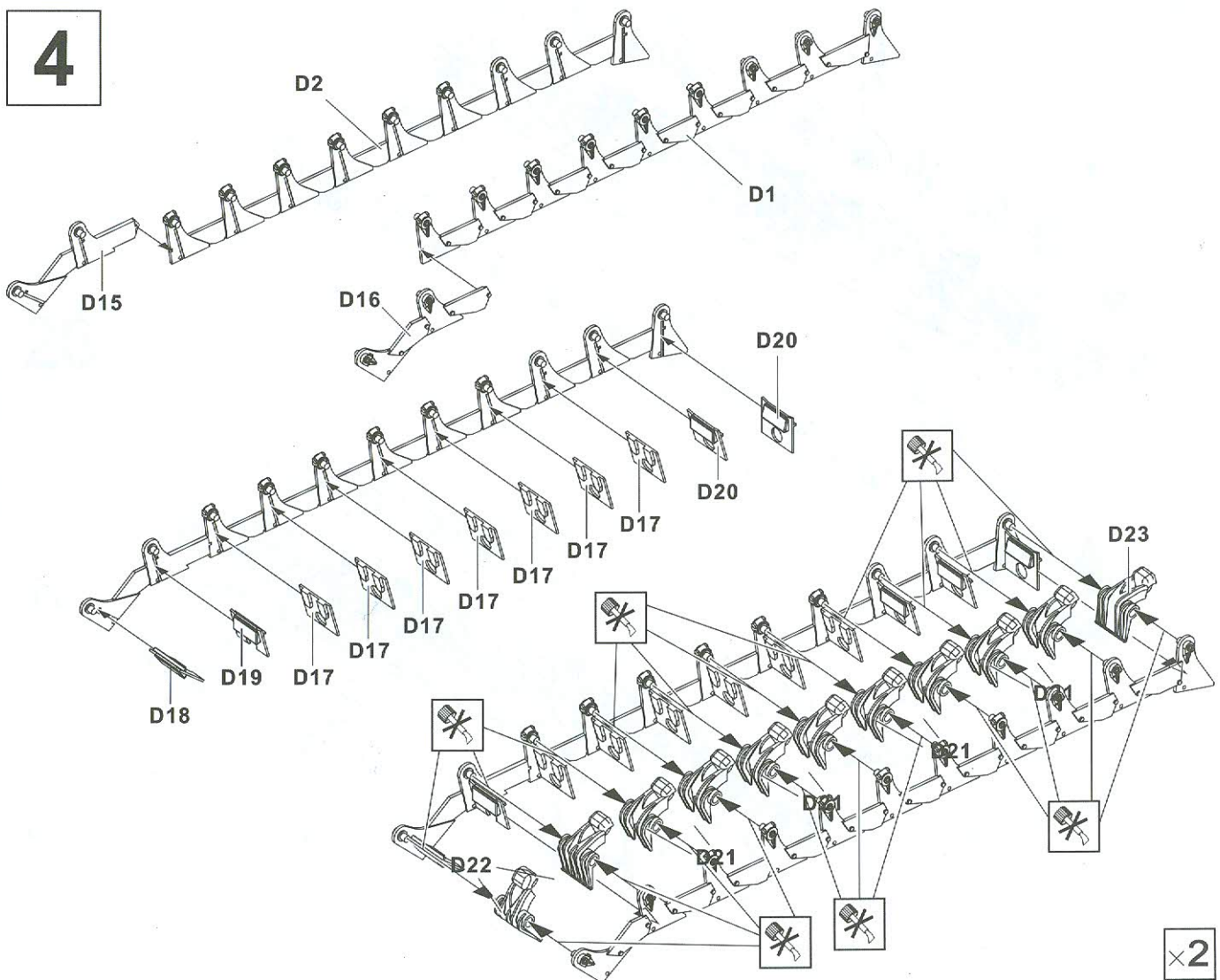

5

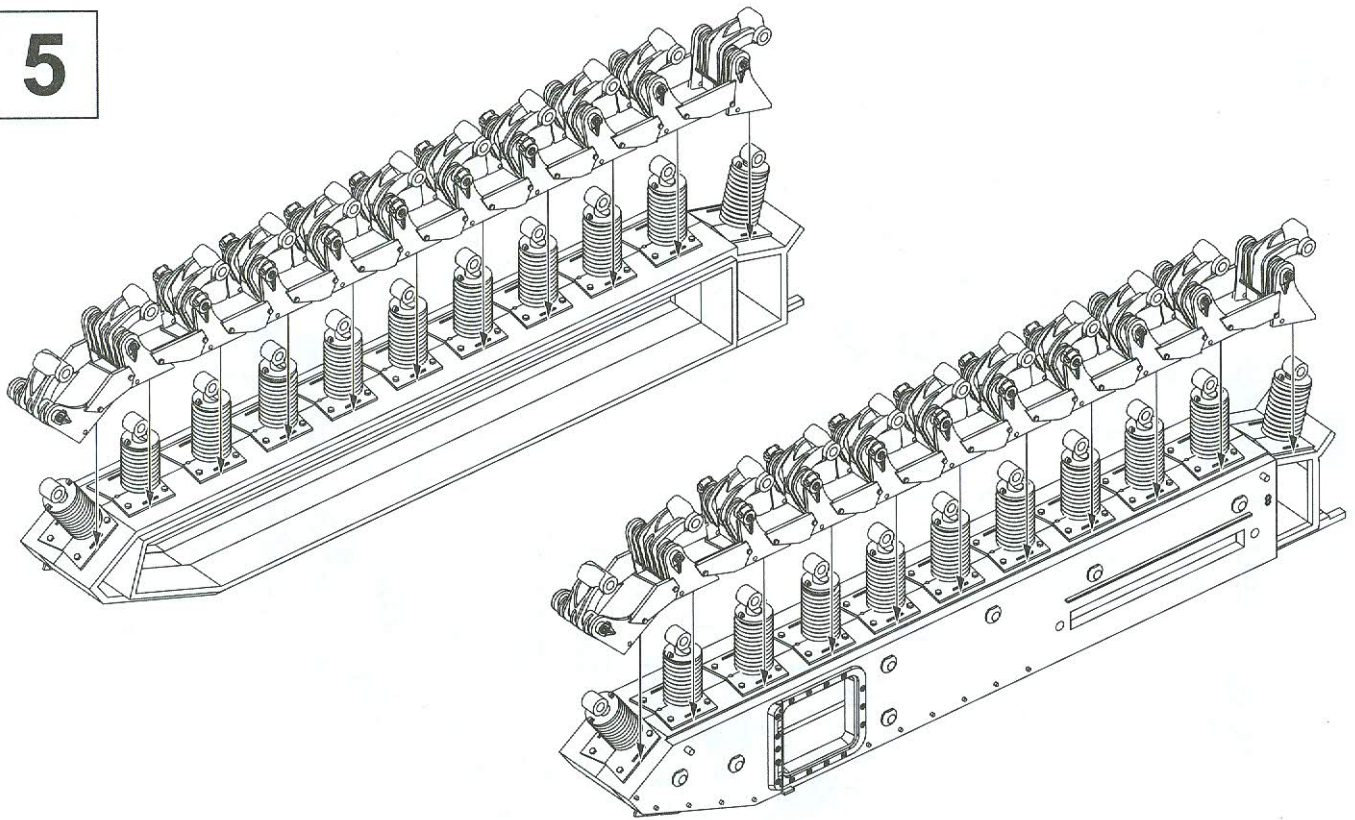

6

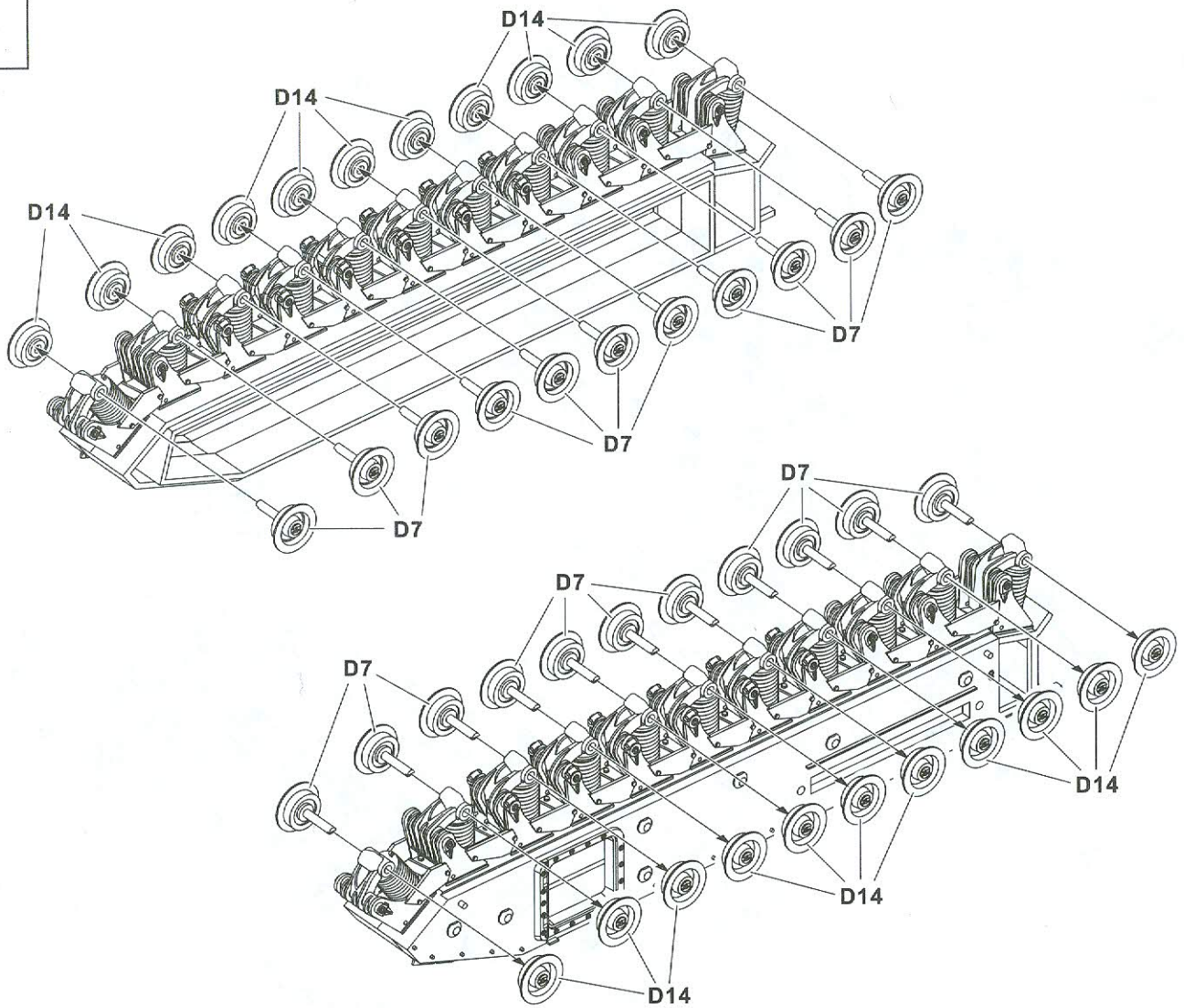

7

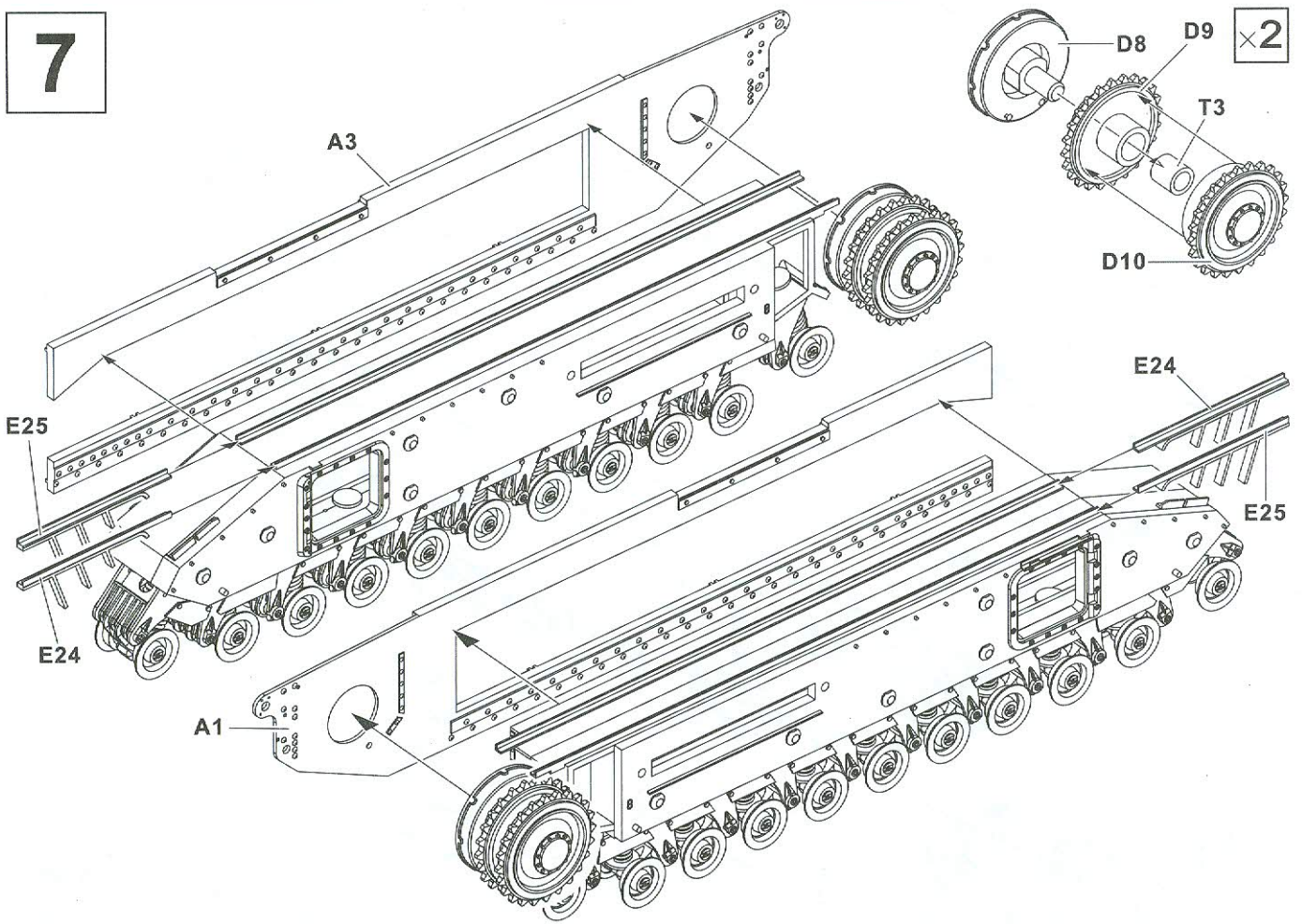

8

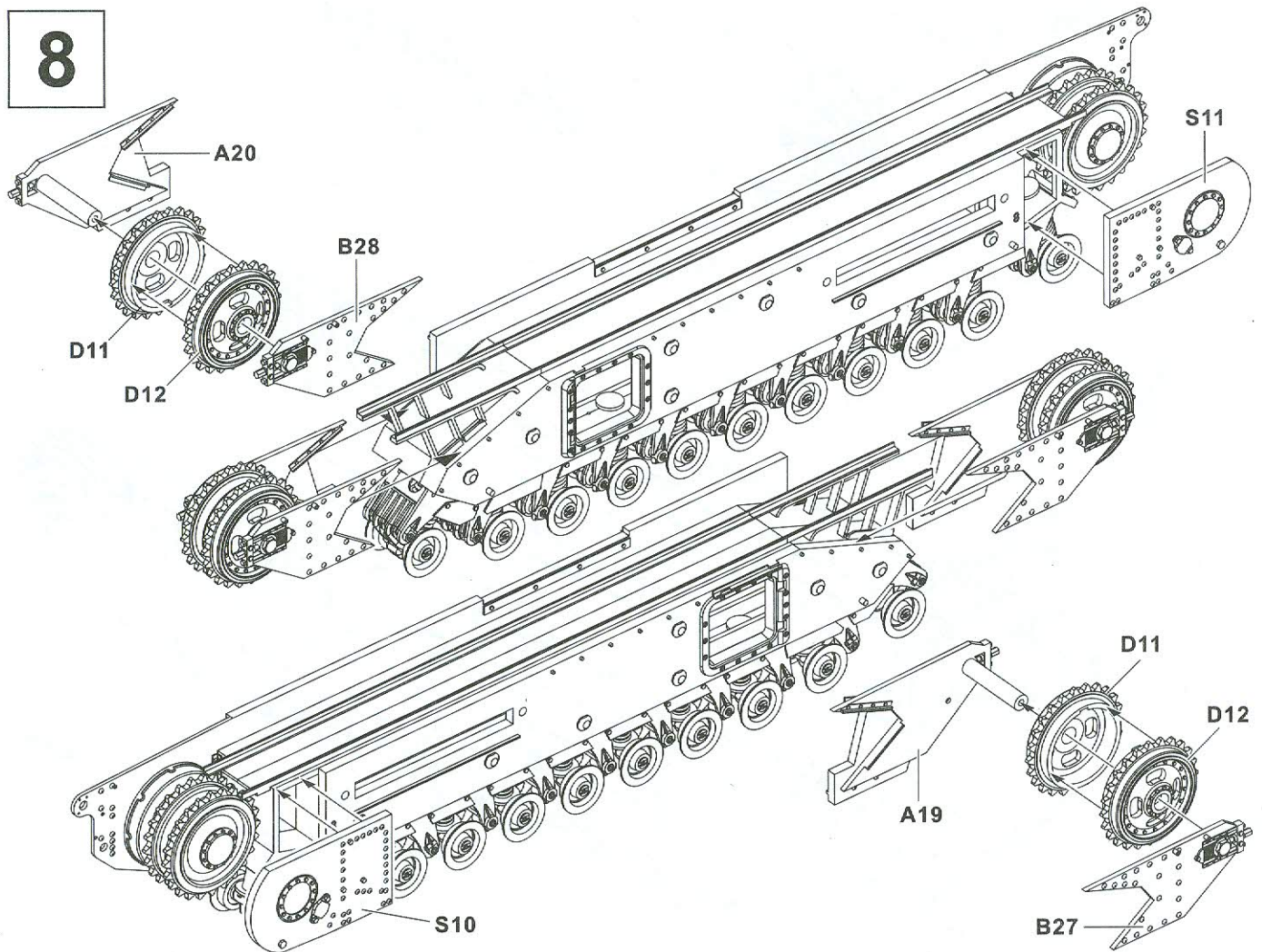

9

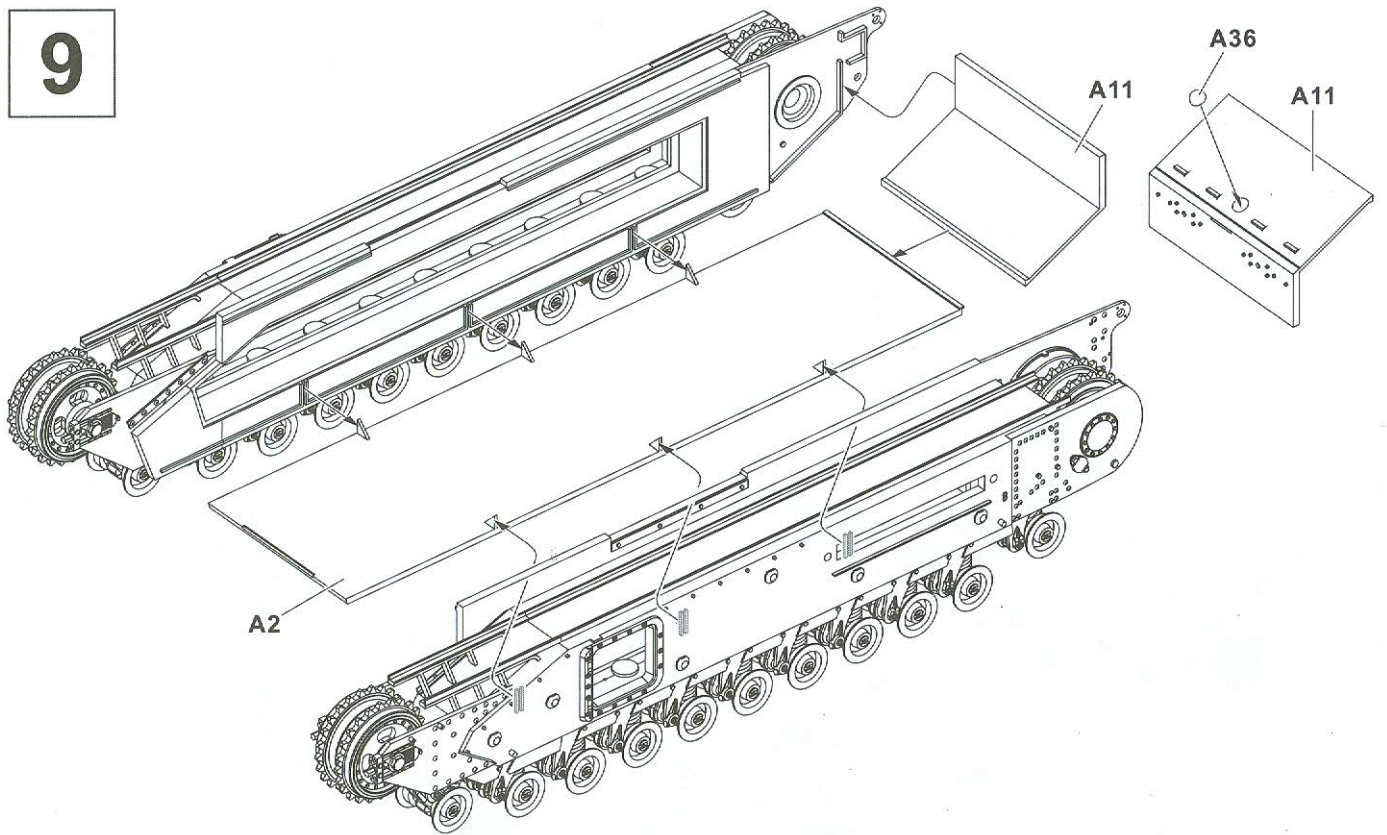

10

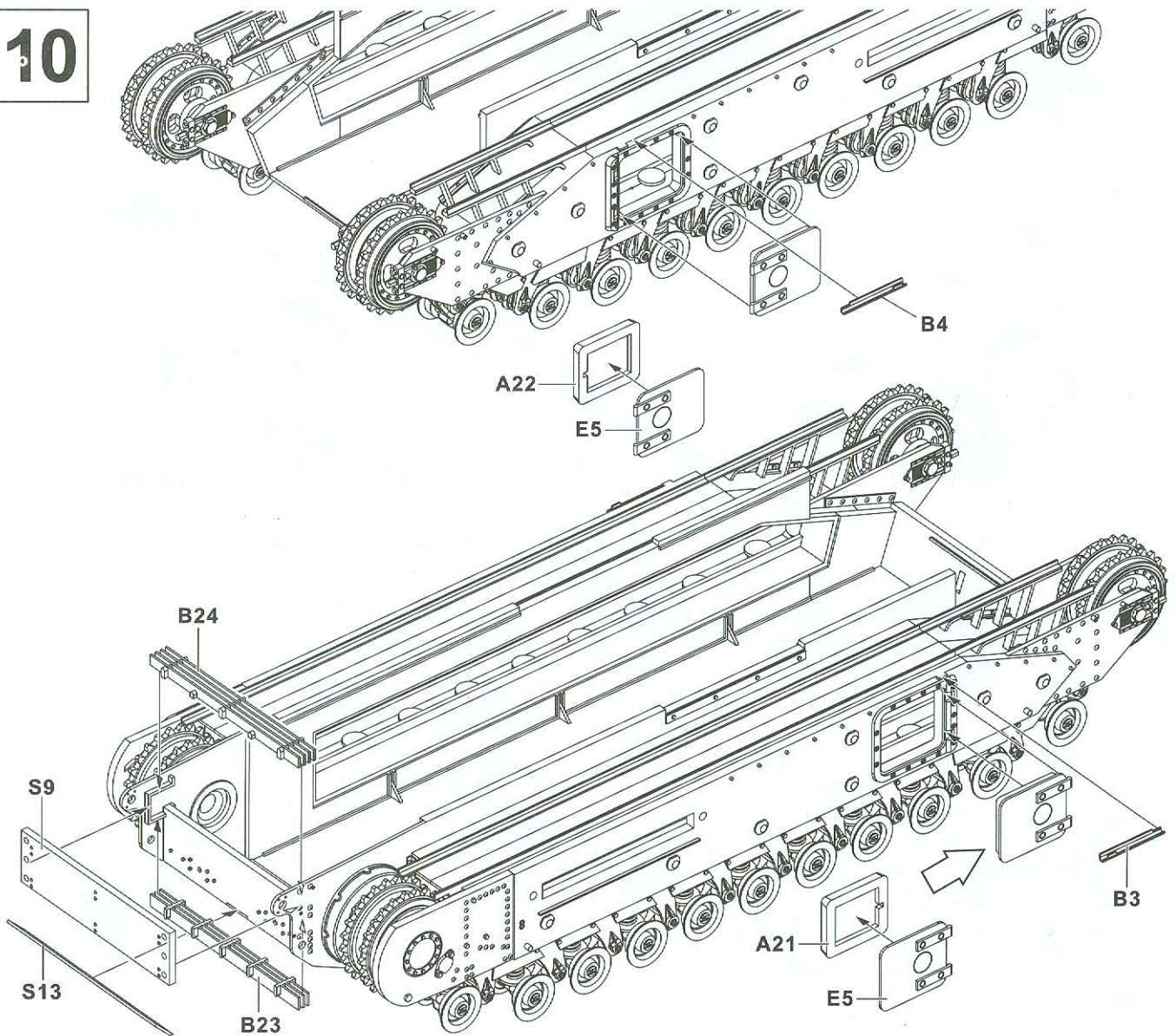

11

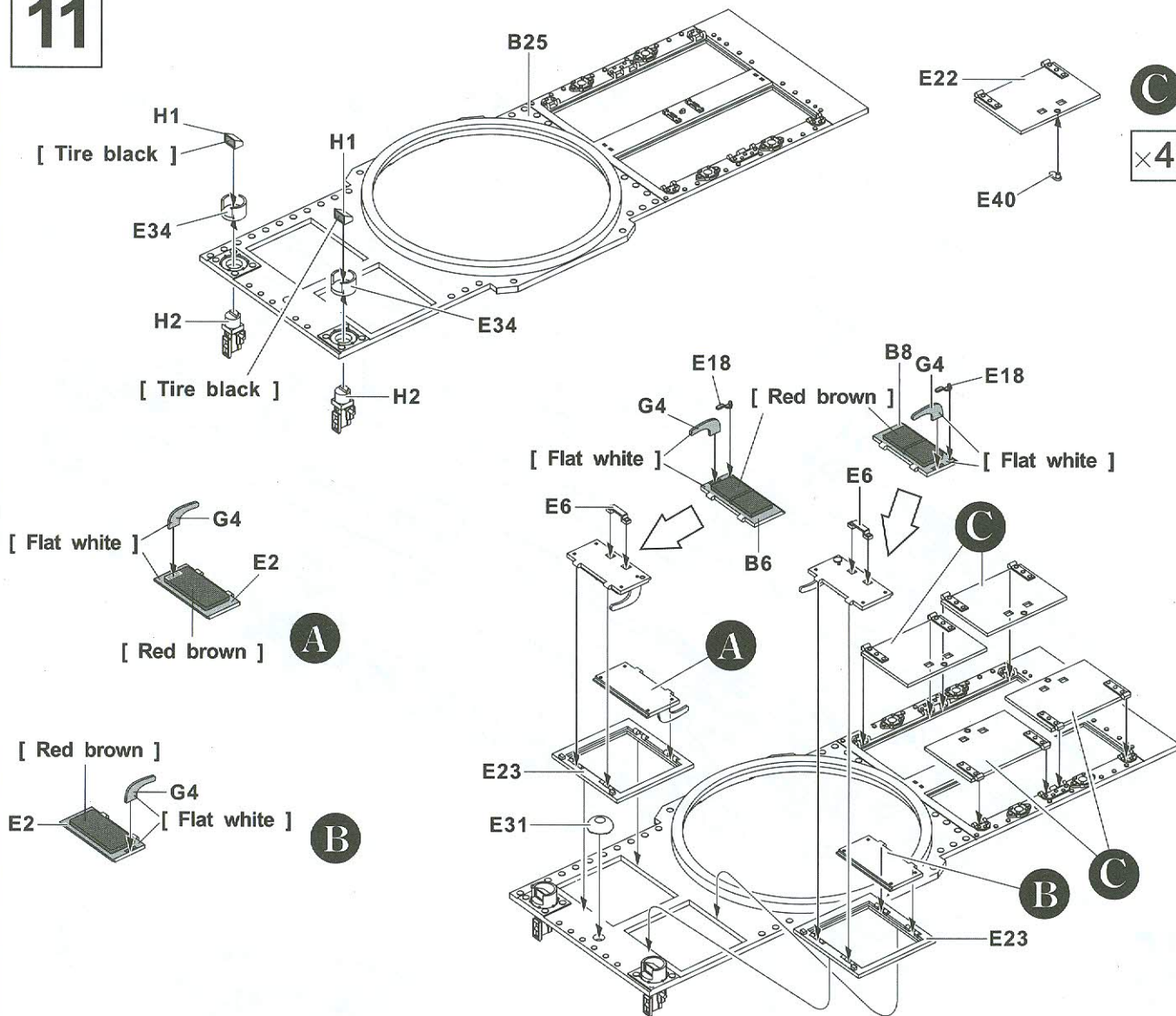

12

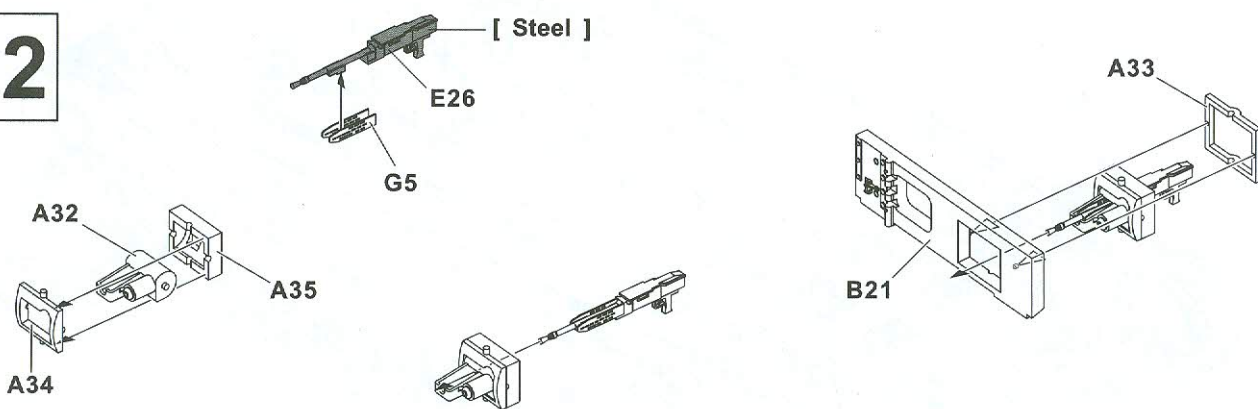

13

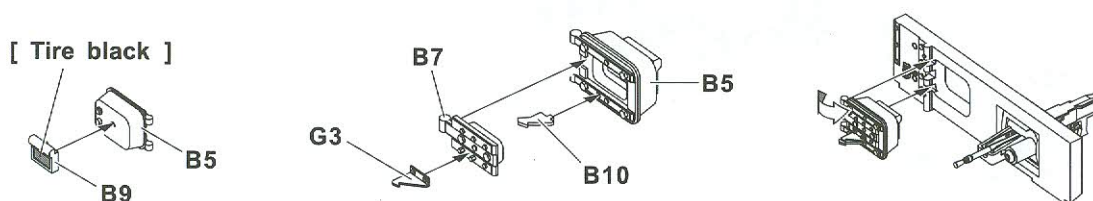

14

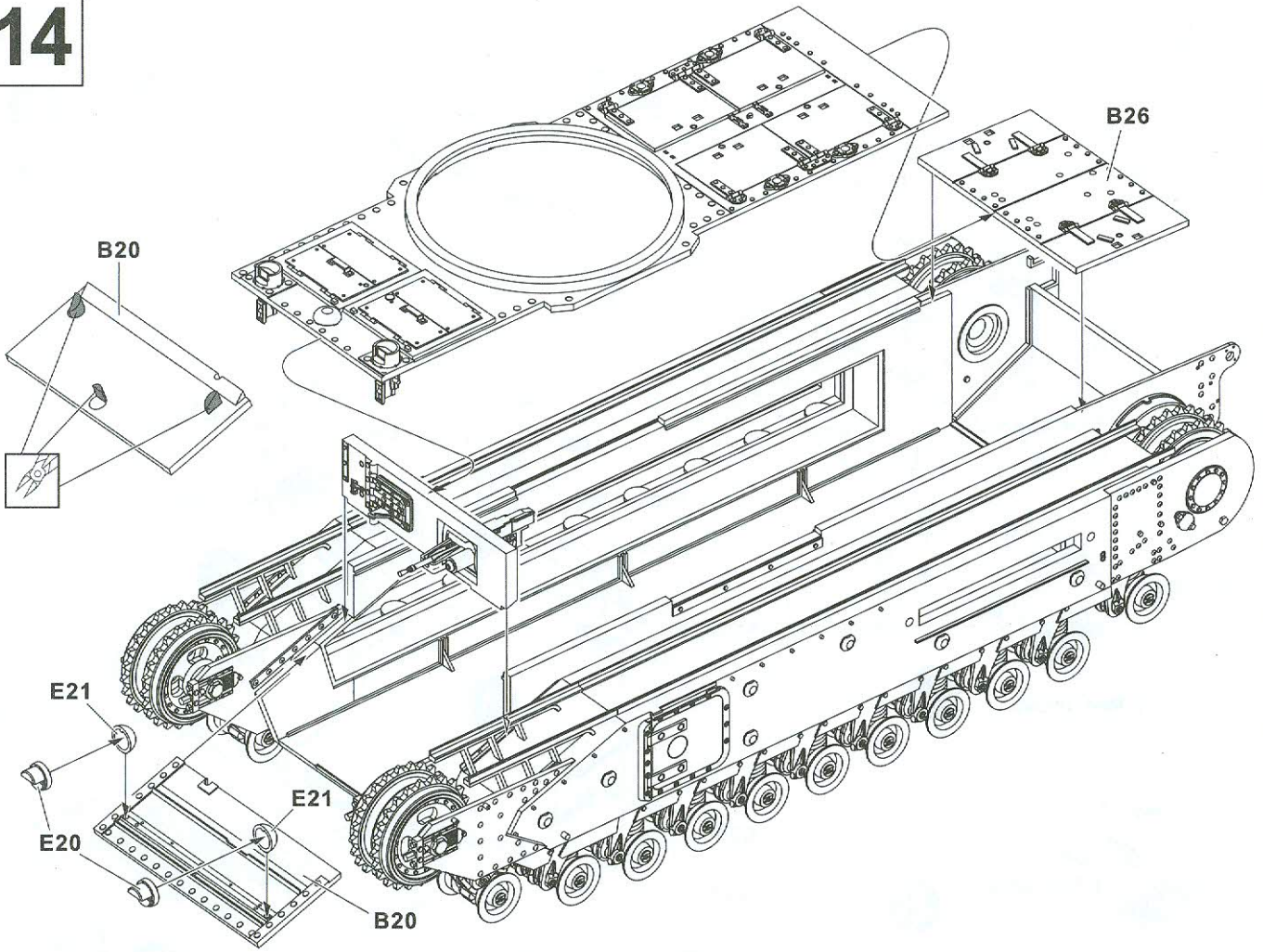

15

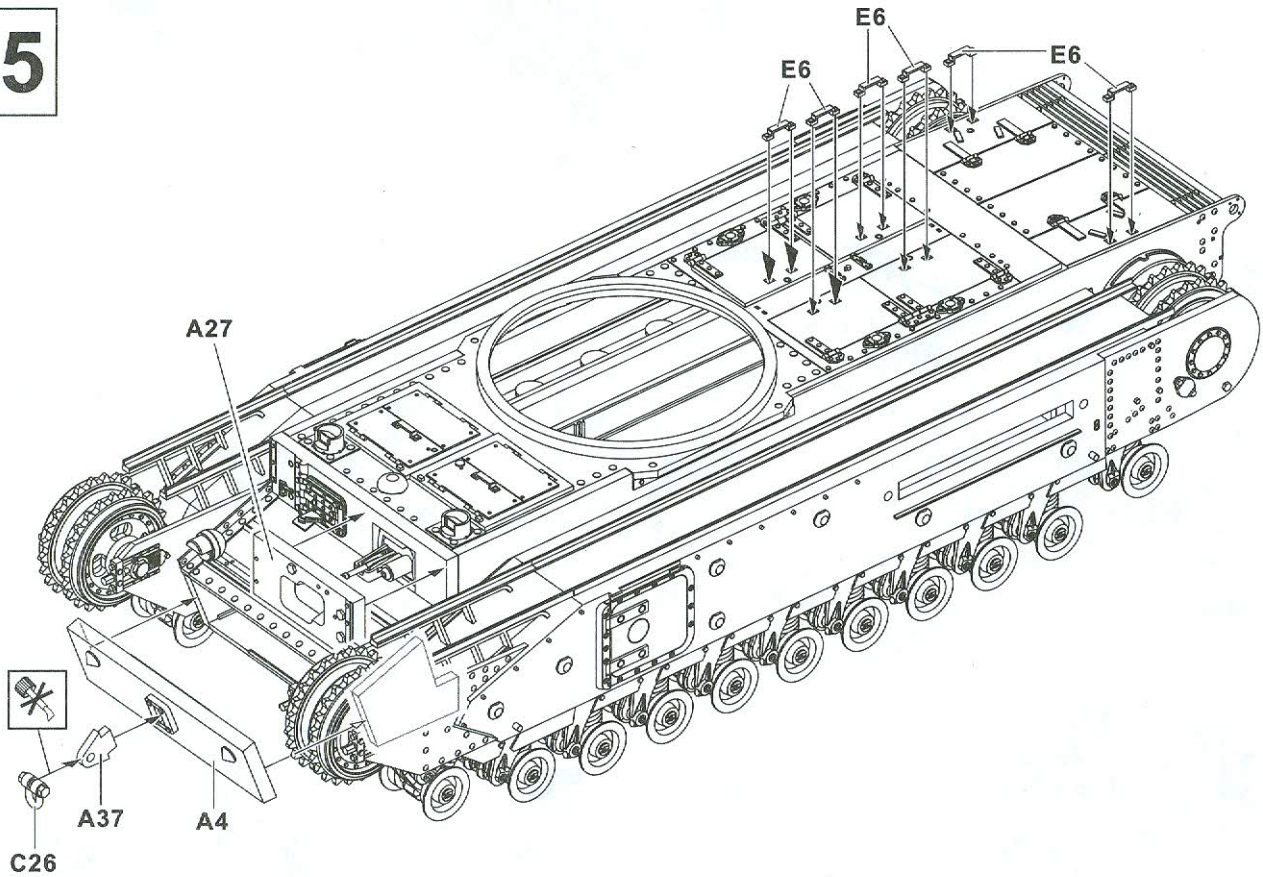

16

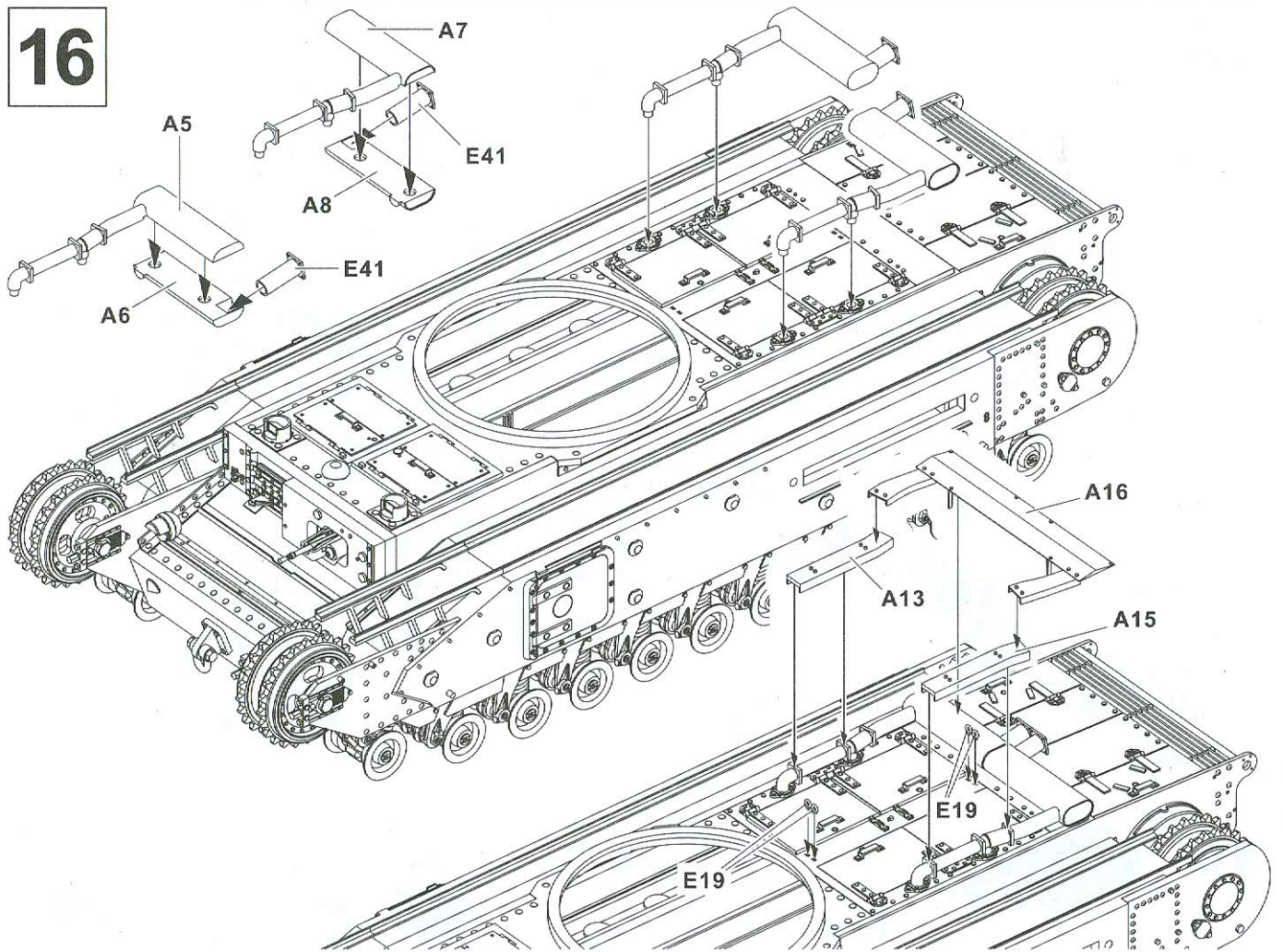

17

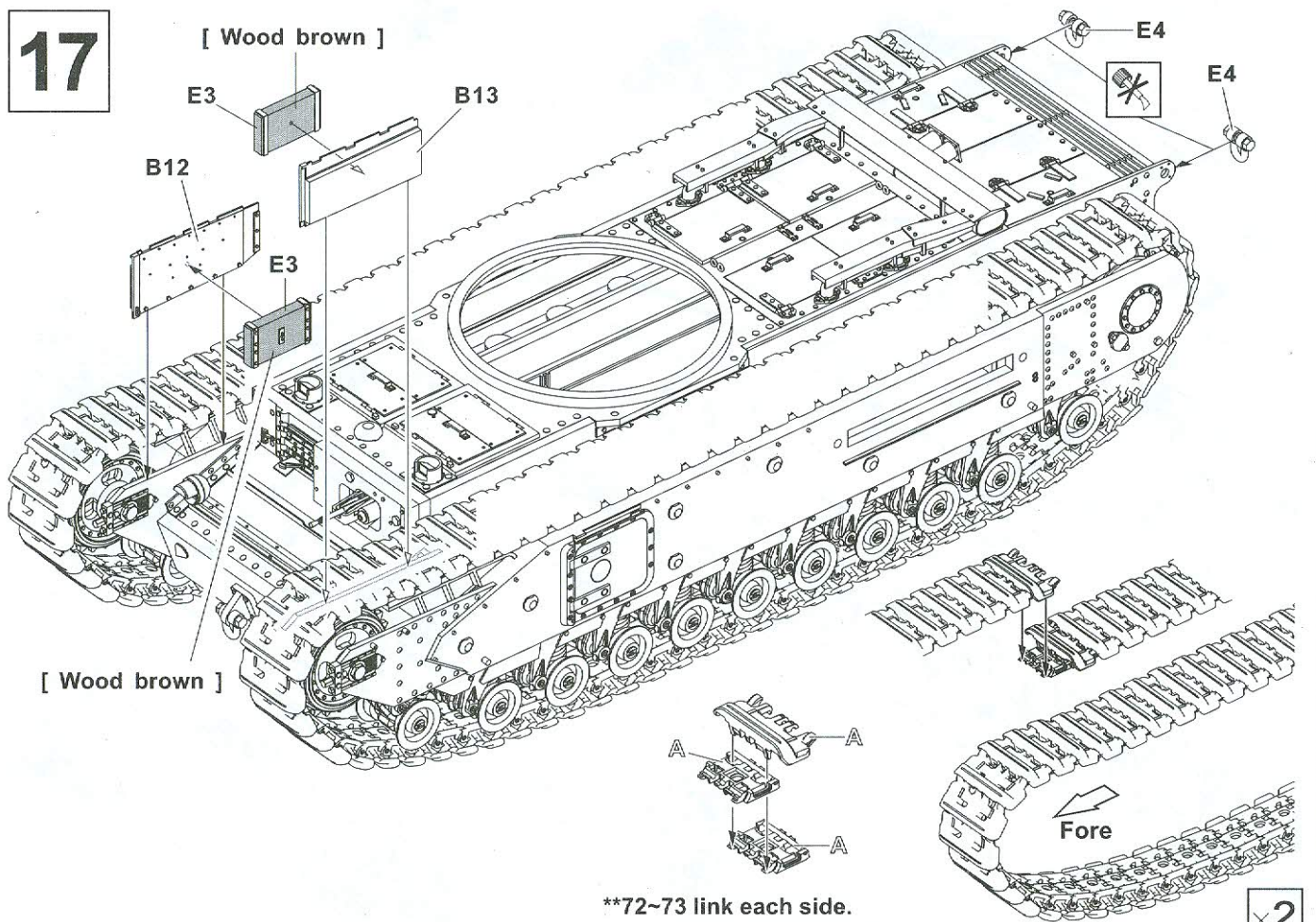

**72~73 link each side.
 **建議每側安裝72至73片履帶。

18

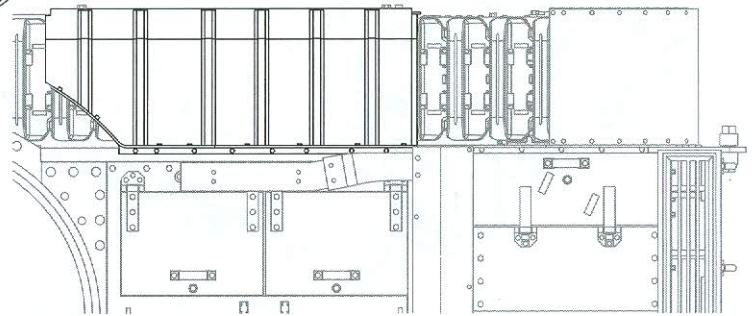
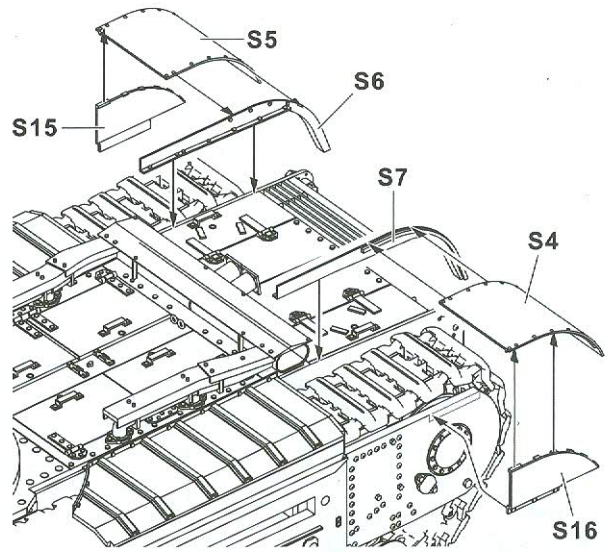
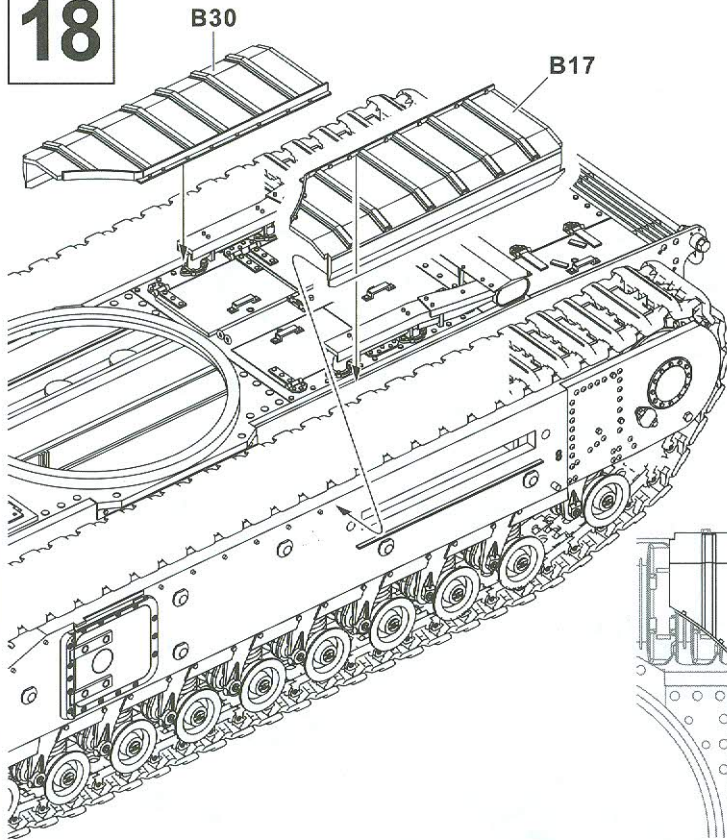

19

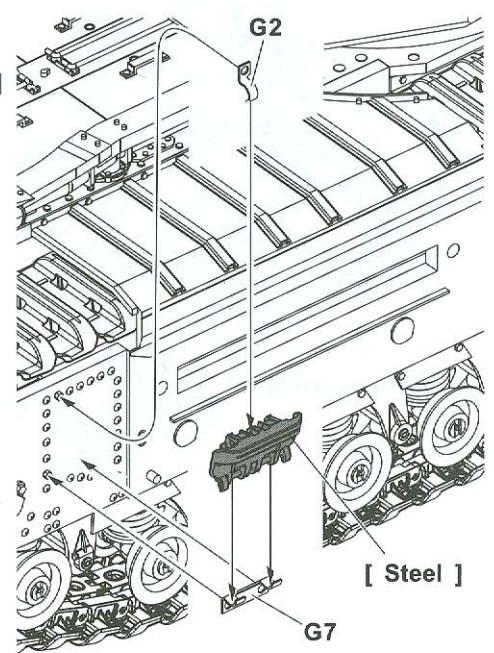
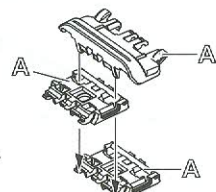
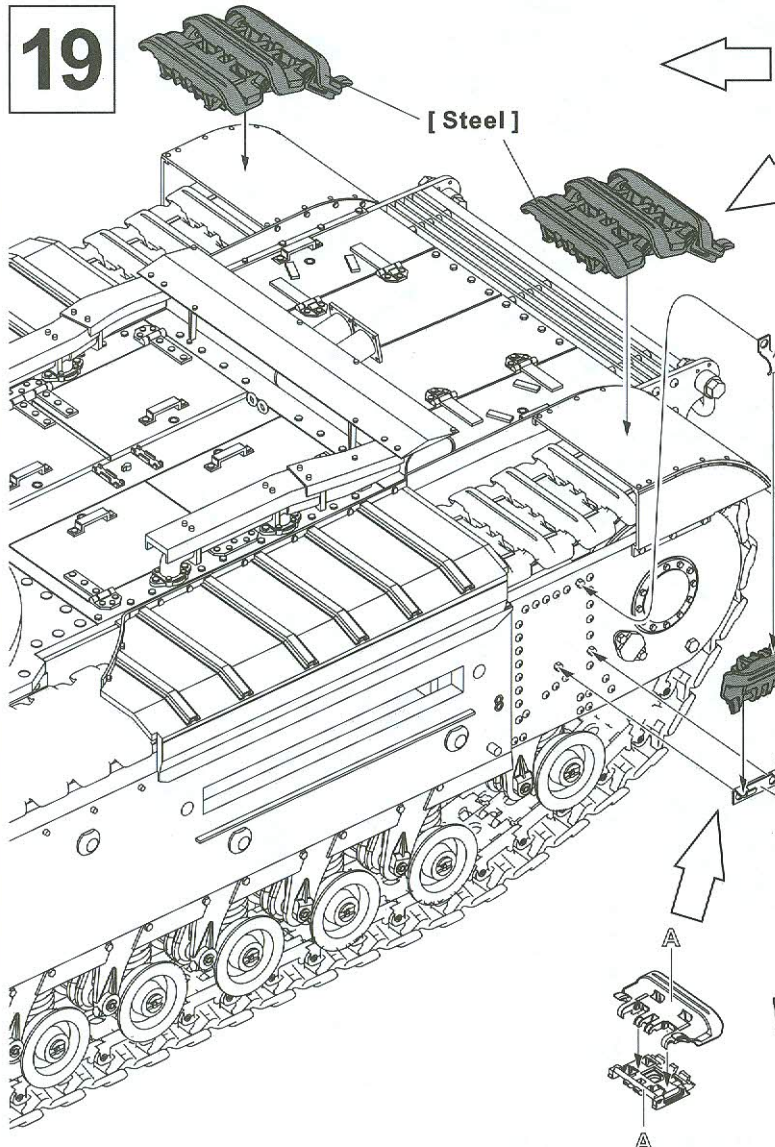

20

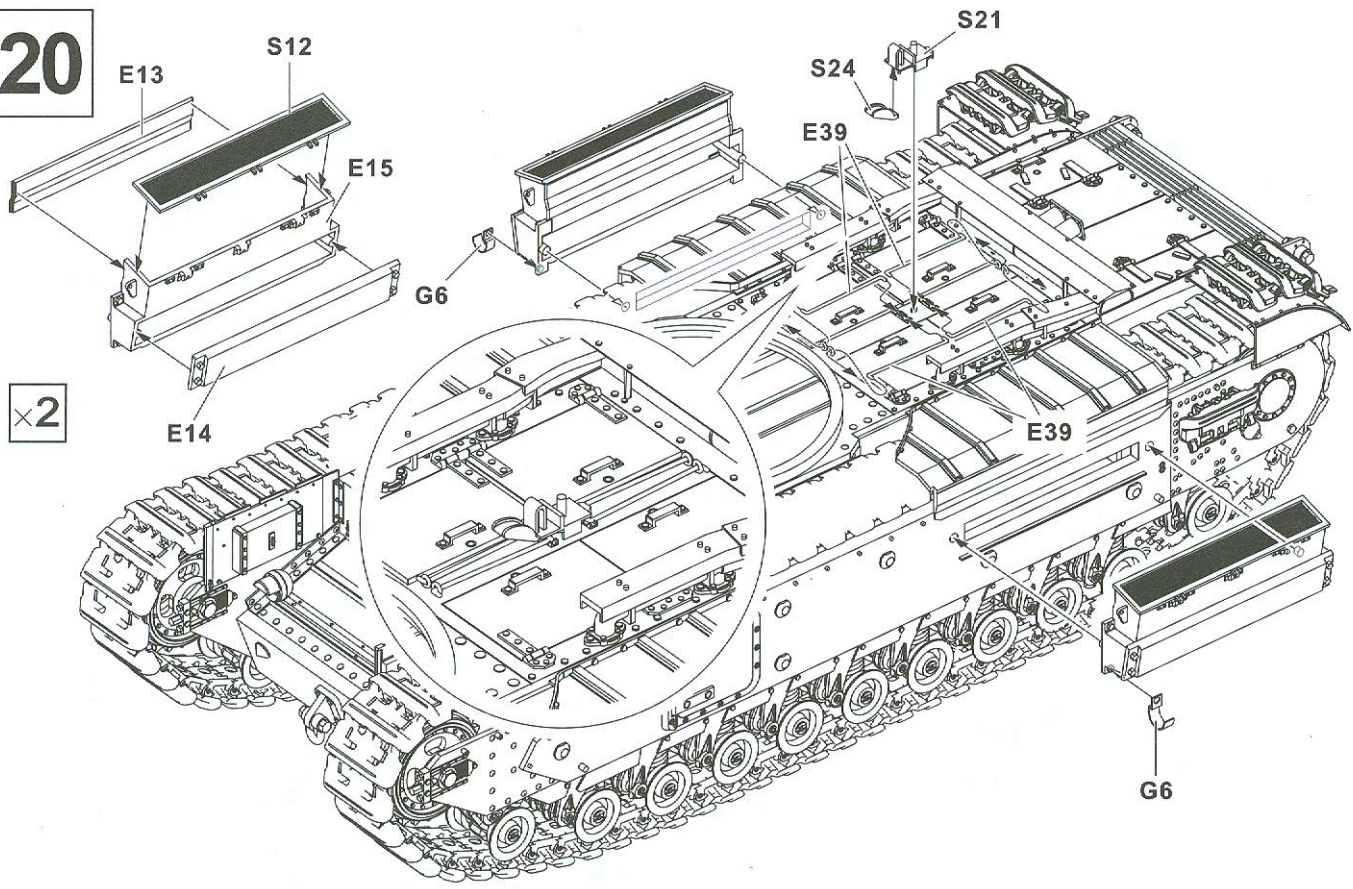

×2

21

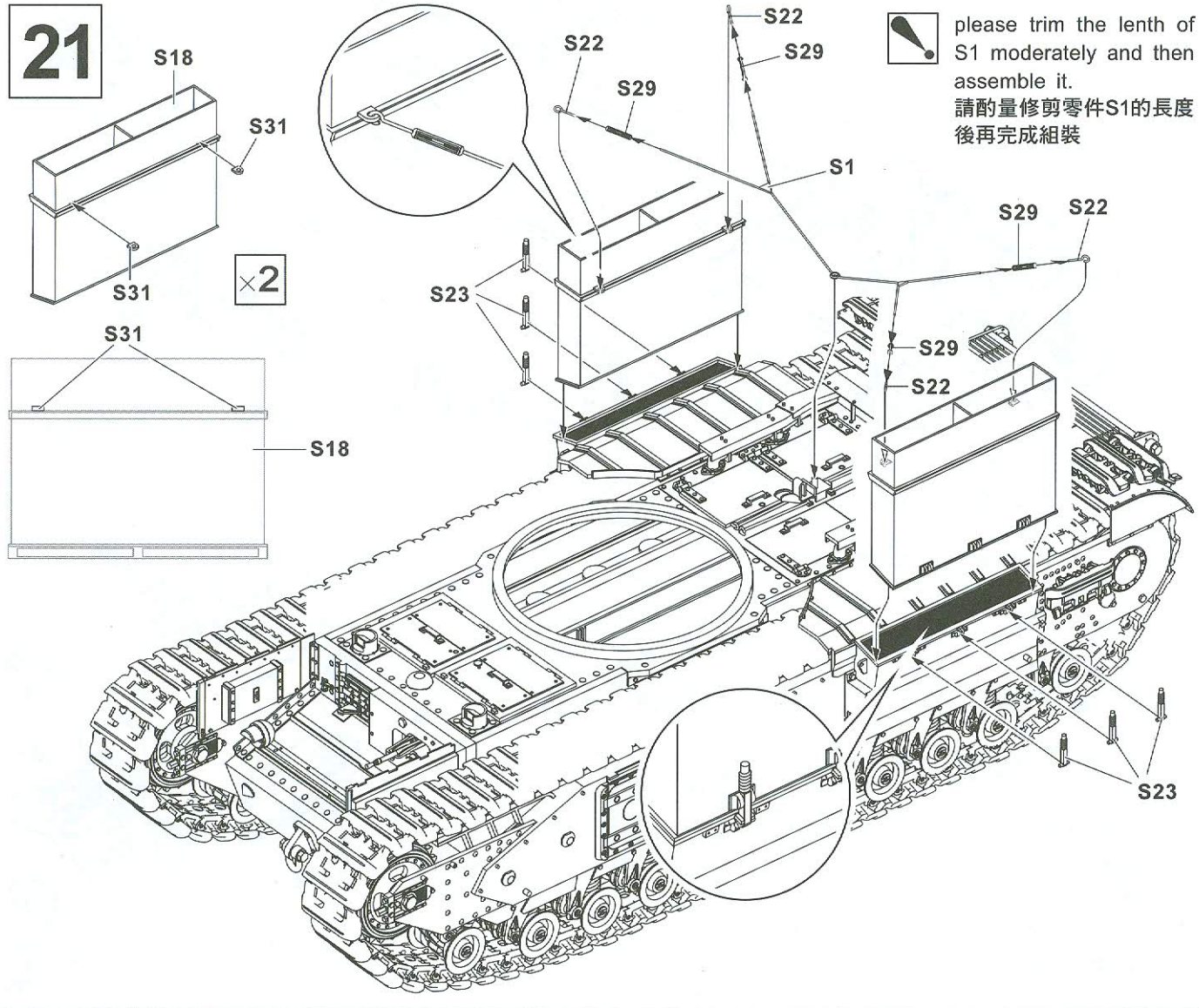

×2



please trim the length of S1 moderately and then assemble it.
請酌量修剪零件S1的長度後再完成組裝

22

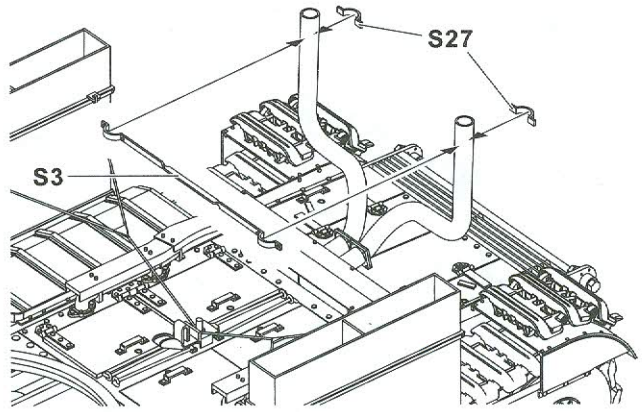
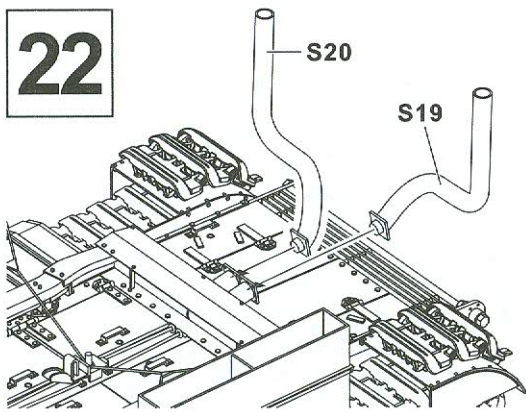

23



please trim the length of S2 moderately and then assemble it.
請酌量修剪零件S2的長度後再完成組裝

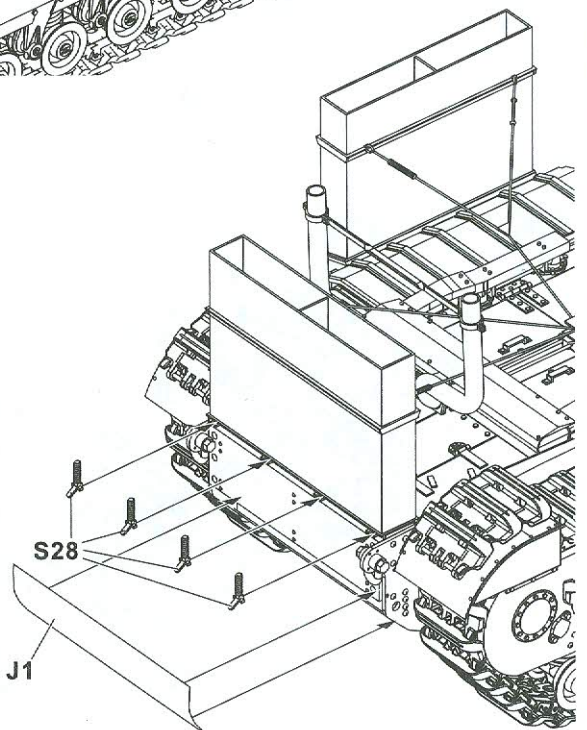
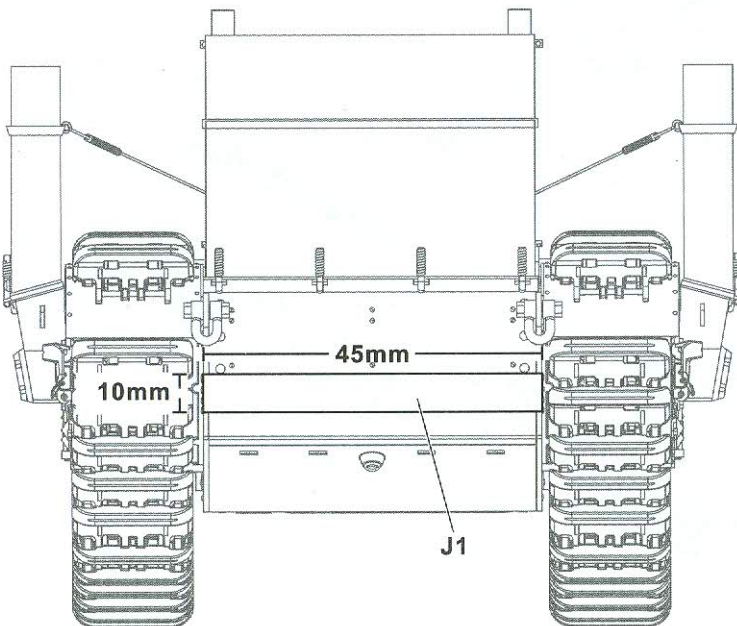
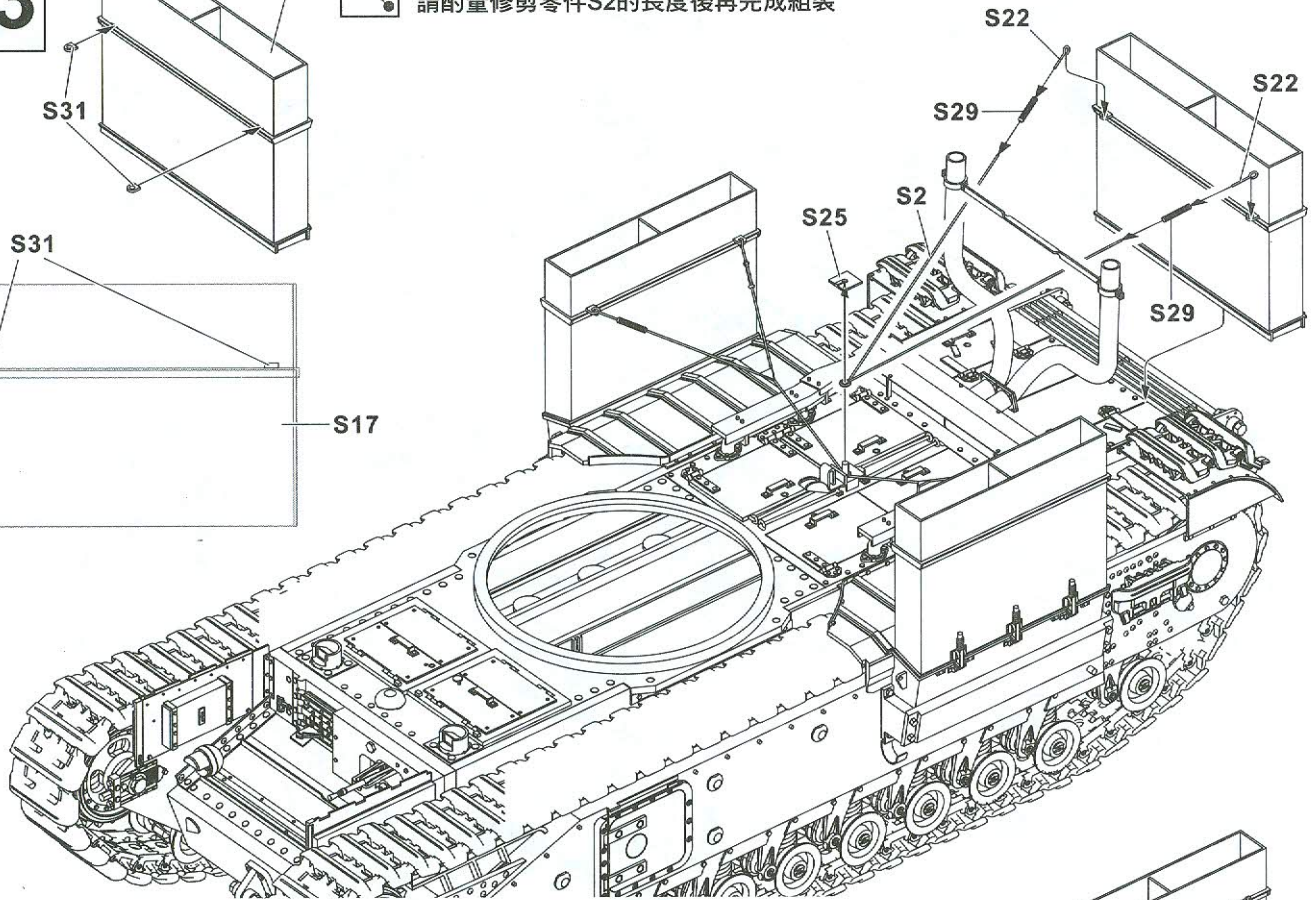
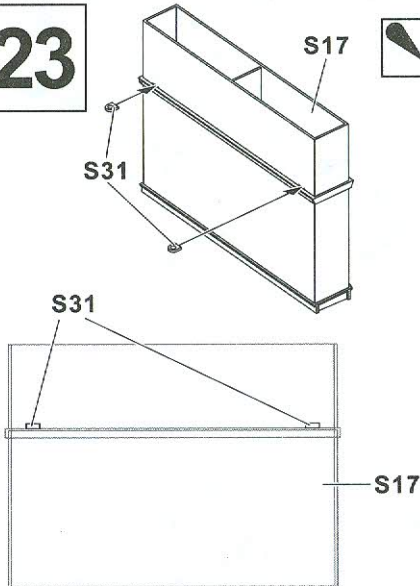

24

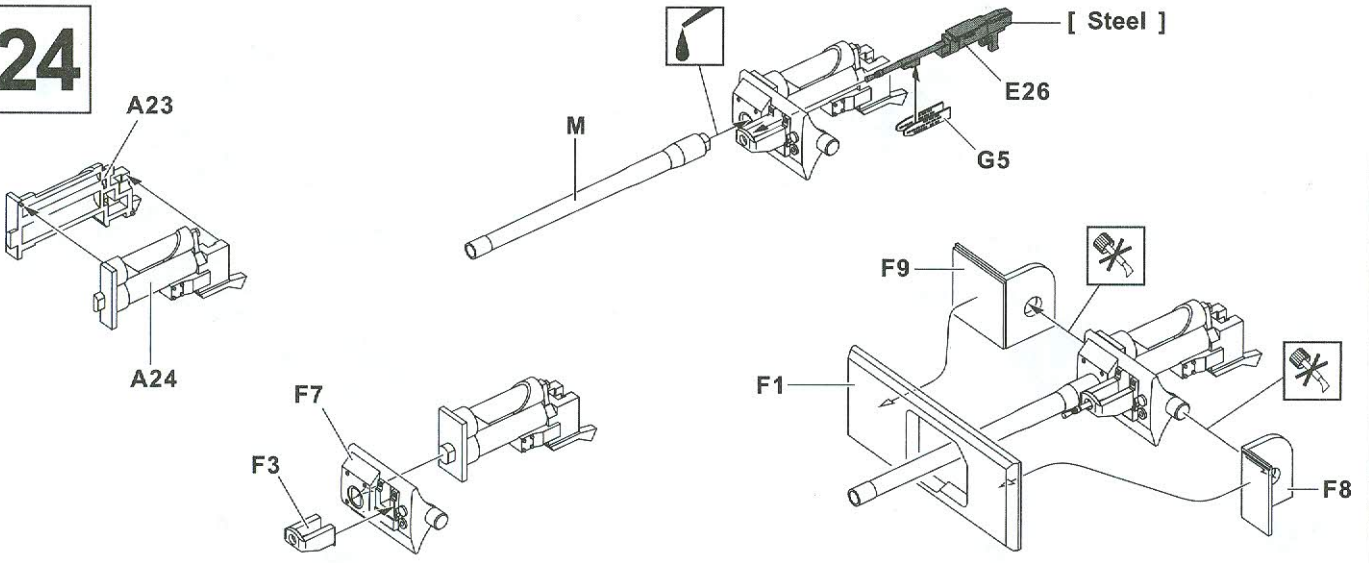

25

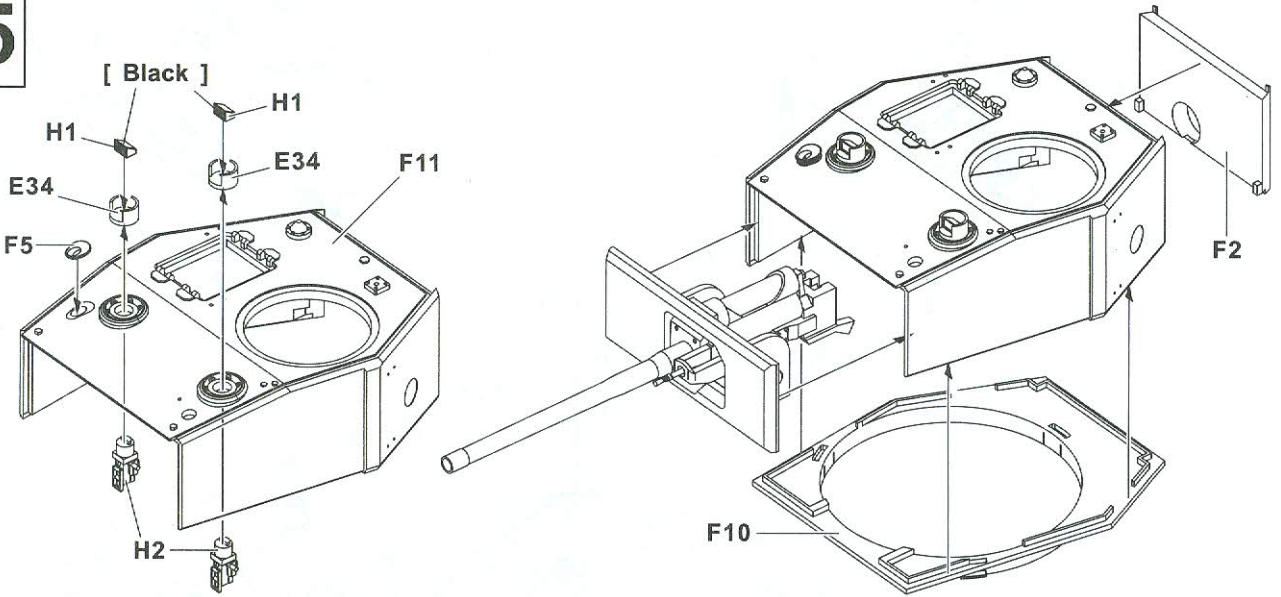

26

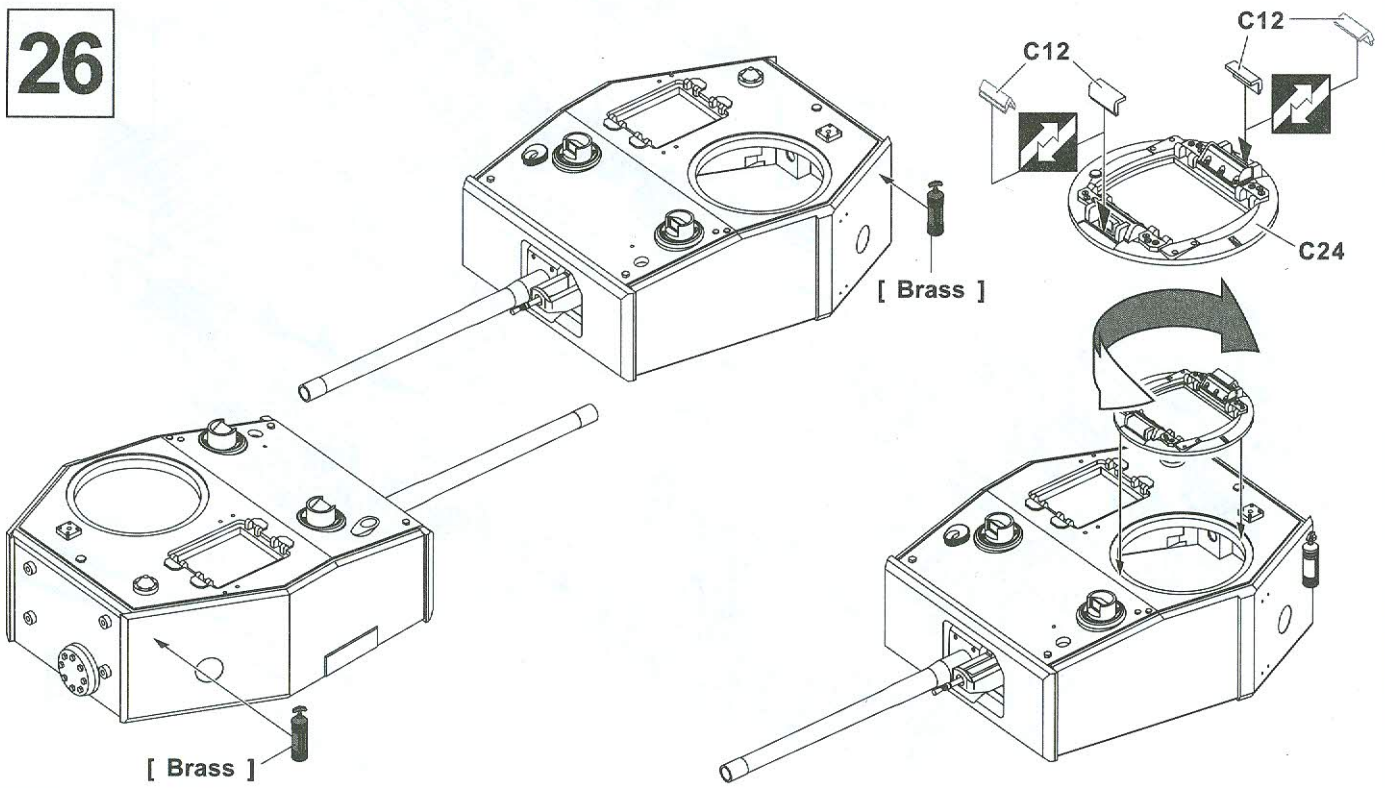

27

[Red brown]

[Flat white]

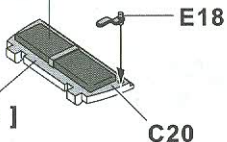

[Red brown]

[Flat white]

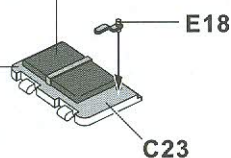

C23 C20

C22 C19

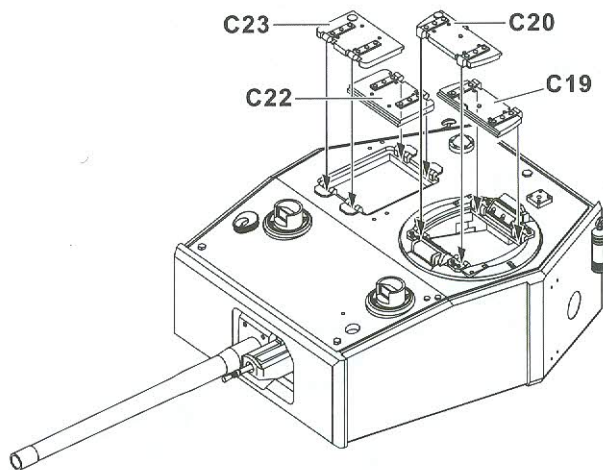

28

E31

E17

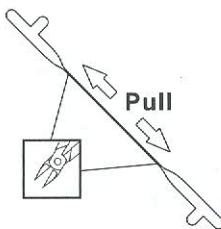
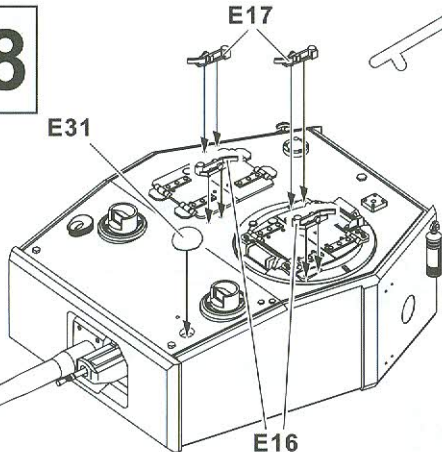
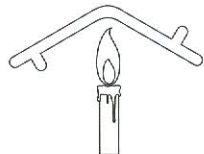

Pull

7mm C25 C13

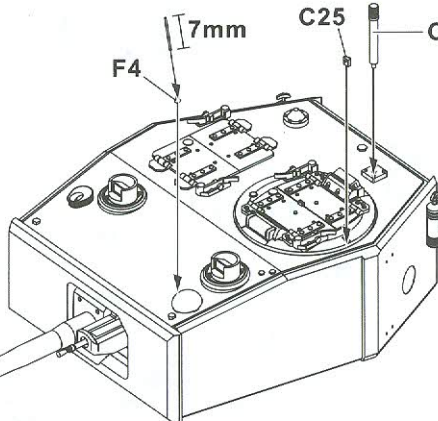

3cm

2cm

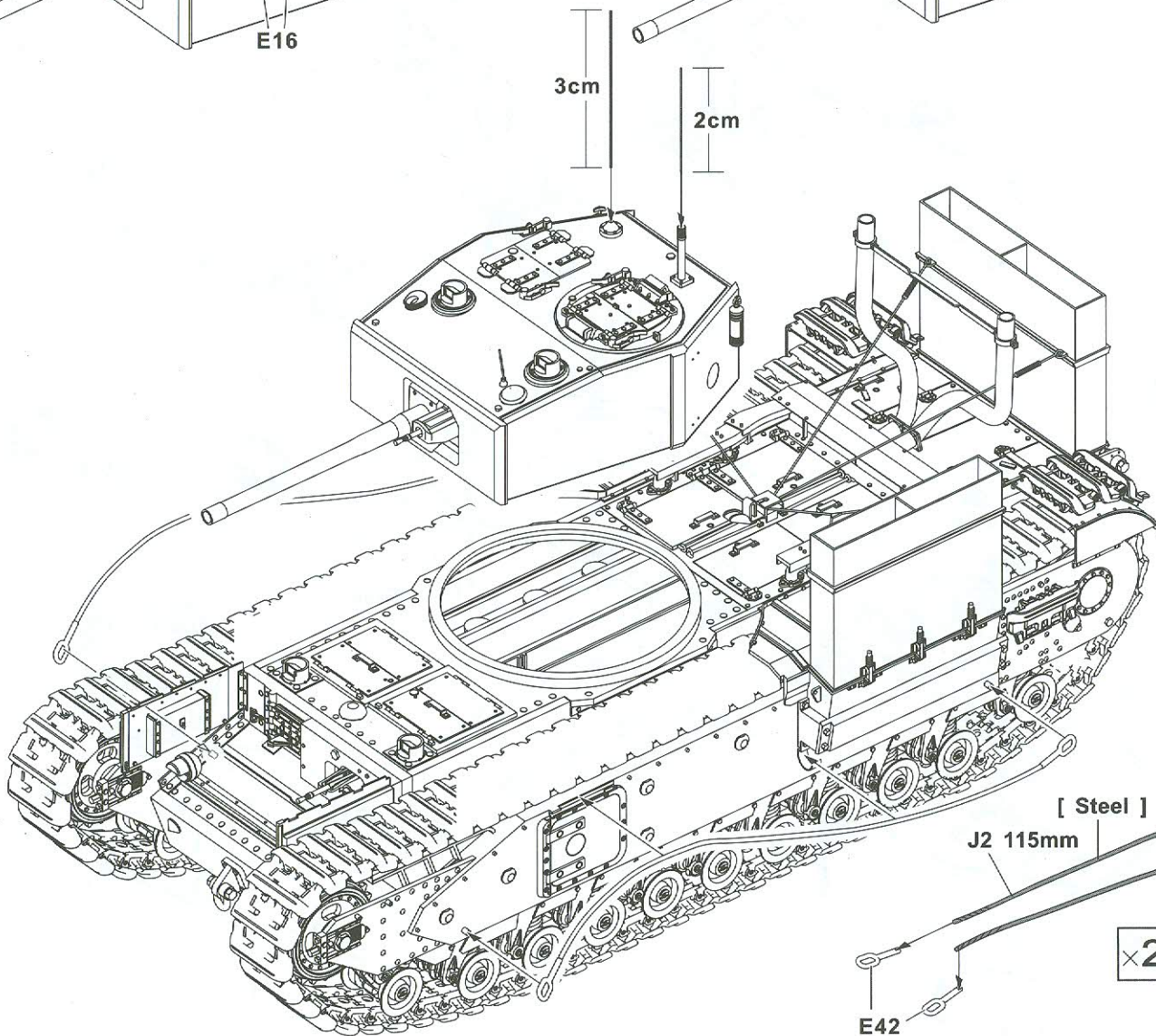

[Steel]

J2 115mm

E42

×2

A 13 troop, C Sqn, 14th Canadian Army Tank Regiment (Calgary Regiment)
 加拿大第十四戰車團(卡爾加里團),C連第十三排所屬車

 Body Color: Khaki

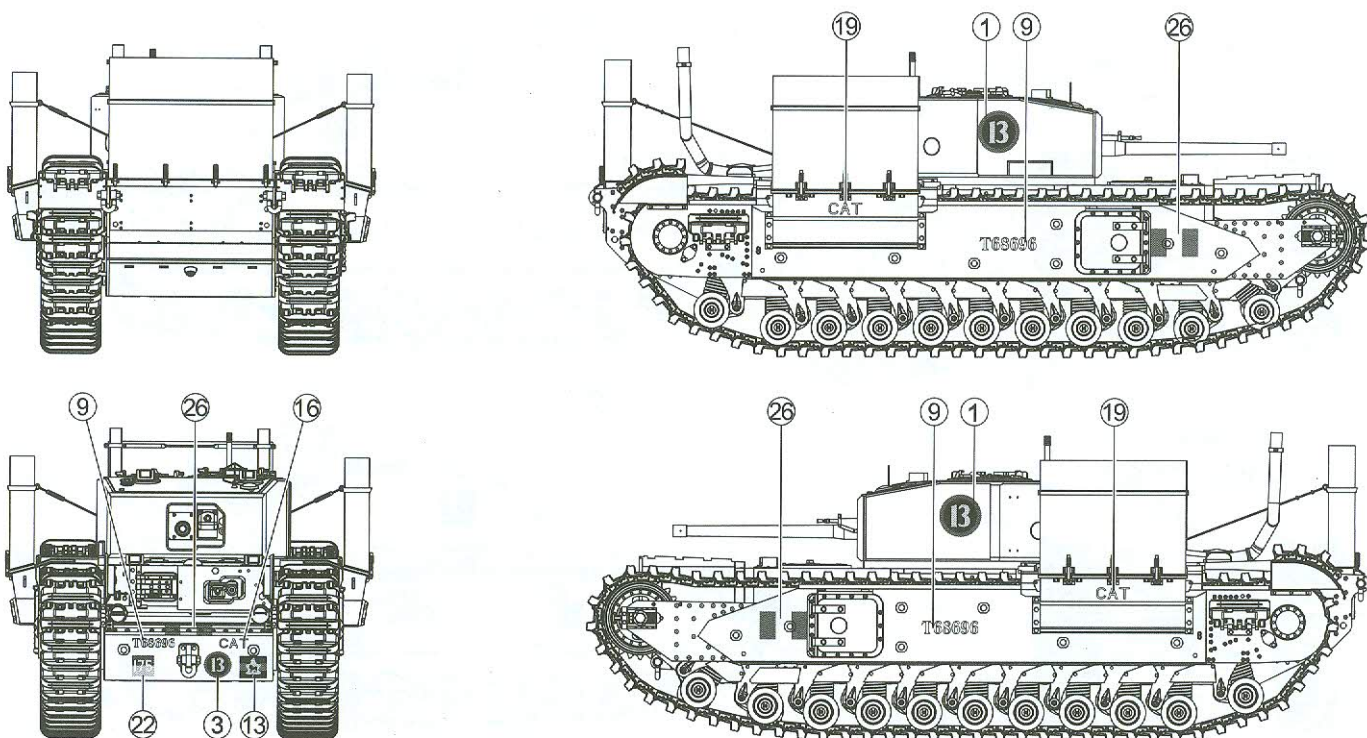

B 6 troop, B Sqn, 14th Canadian Army Tank Regiment (Calgary Regiment)
 加拿大第十四戰車團(卡爾加里團),B連第六排所屬車

 Body Color: Khaki

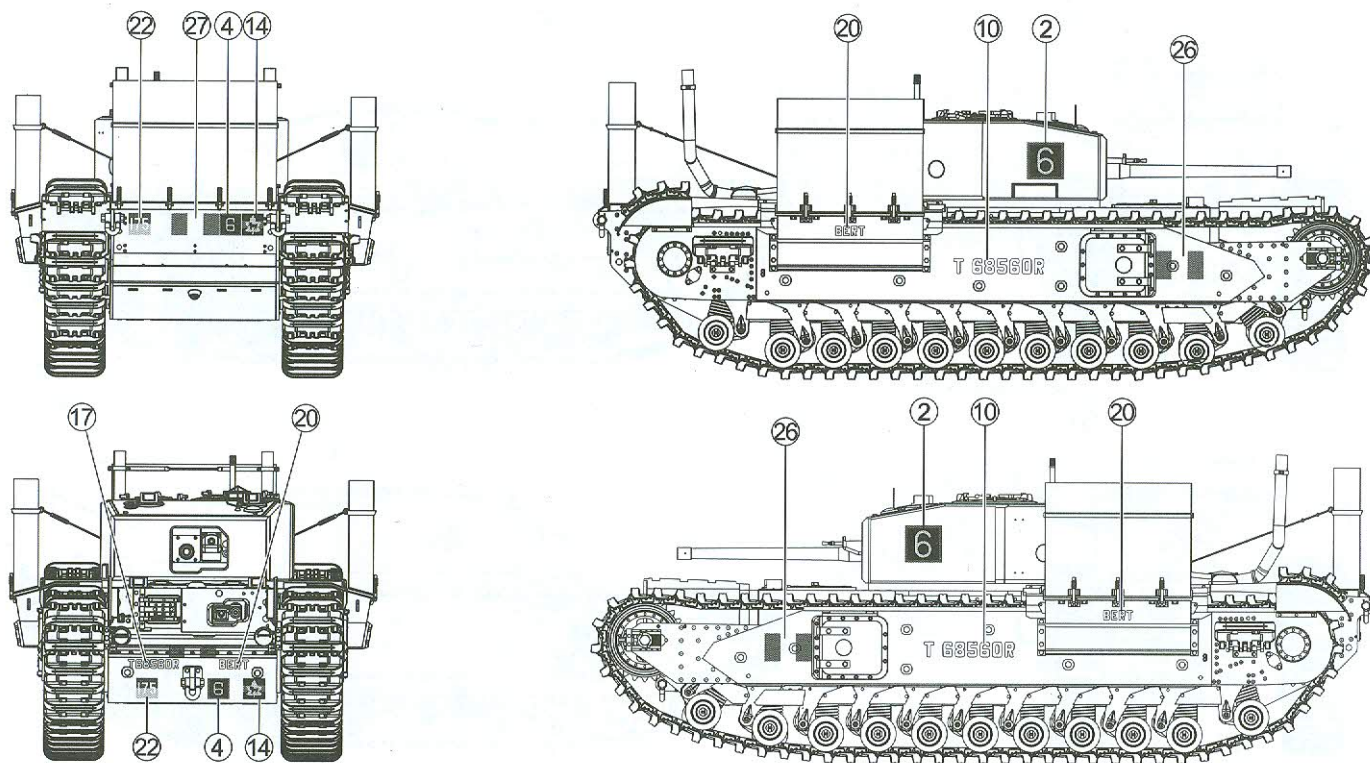

C 7 troop, B Sqn, 14th Canadian Army Tank Regiment (Calgary Regiment)

加拿大第十四戰車團(卡爾加里團),B連第七排所屬車

 Body Color: Khaki

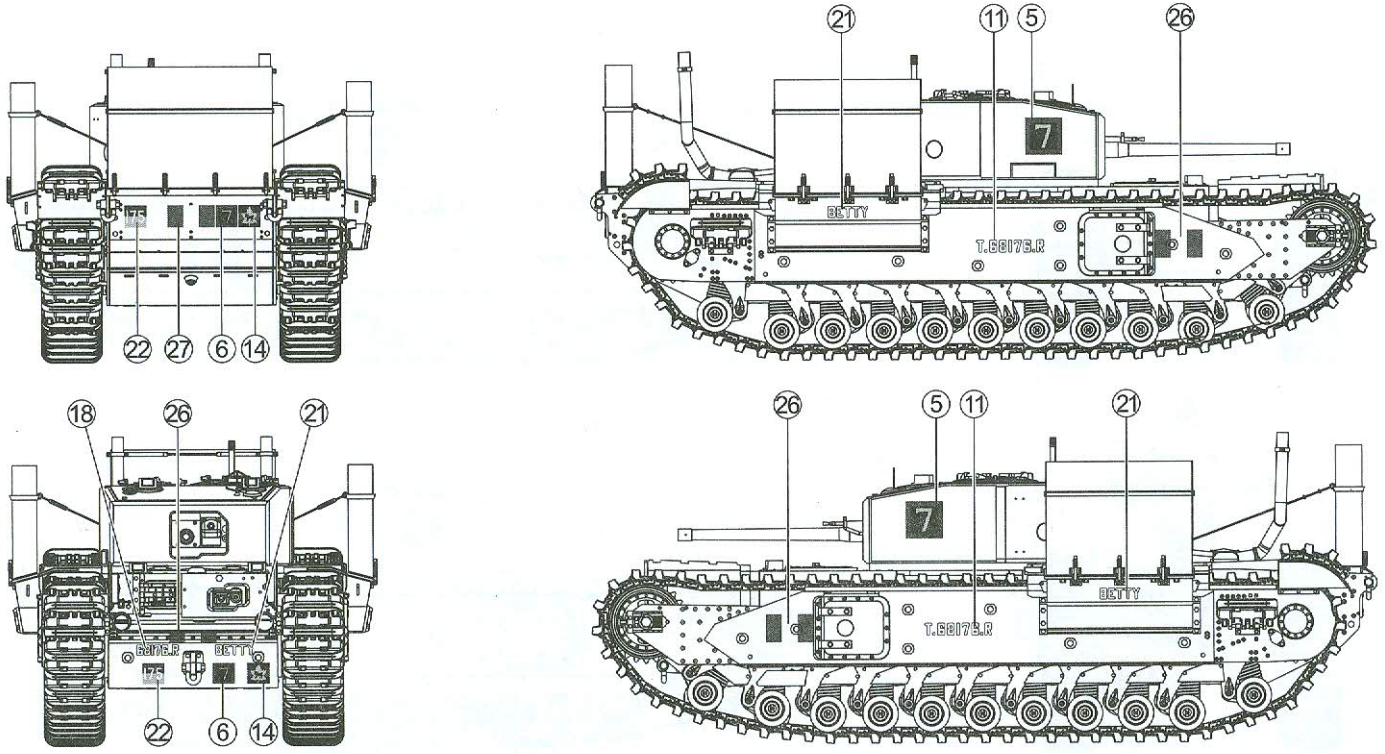

D 10 troop, B Sqn, 14th Canadian Army Tank Regiment (Calgary Regiment)

加拿大第十四戰車團(卡爾加里團),B連第十排所屬車

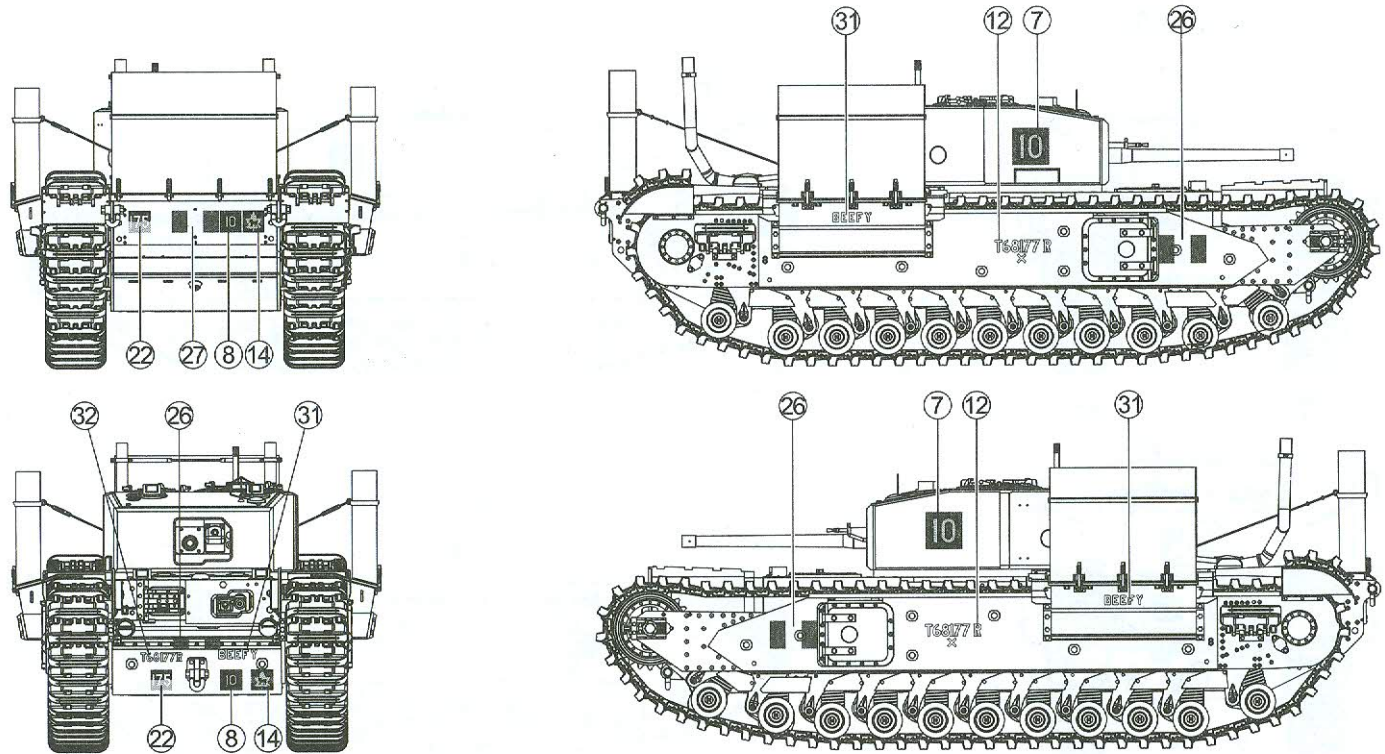

 Body Color: Khaki



E

9 troop, B Sqn, 14th Canadian Army Tank Regiment (Calgary Regiment)

加拿大第十四戰車團(卡爾加里團),B連第九排所屬車

 Body Color: Khaki 

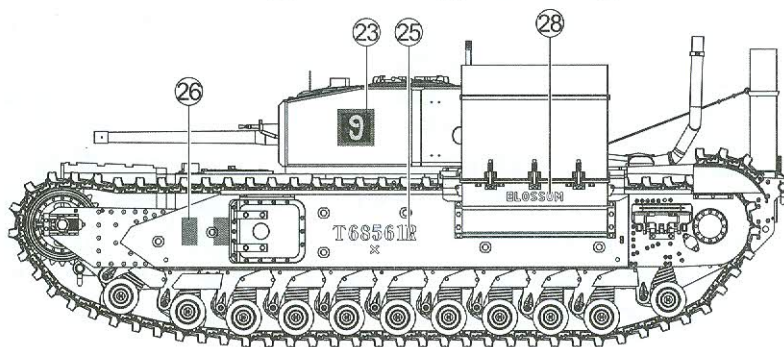
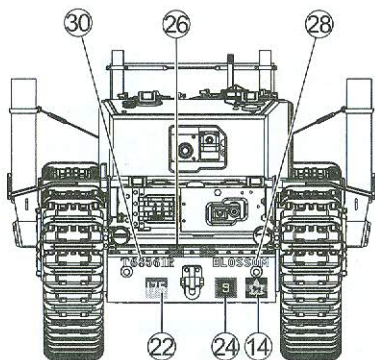
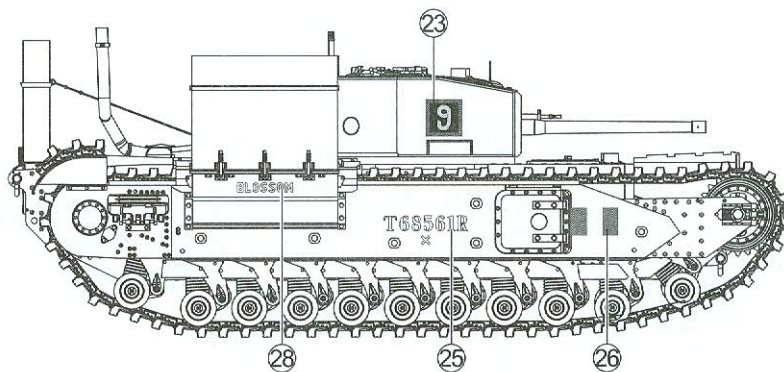
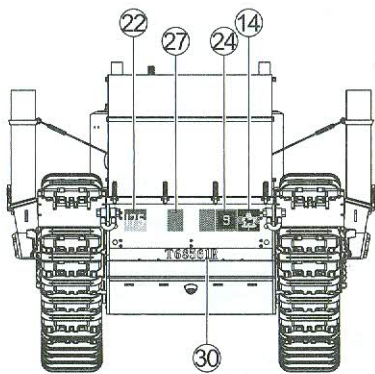

F

 Body Color: German gray 

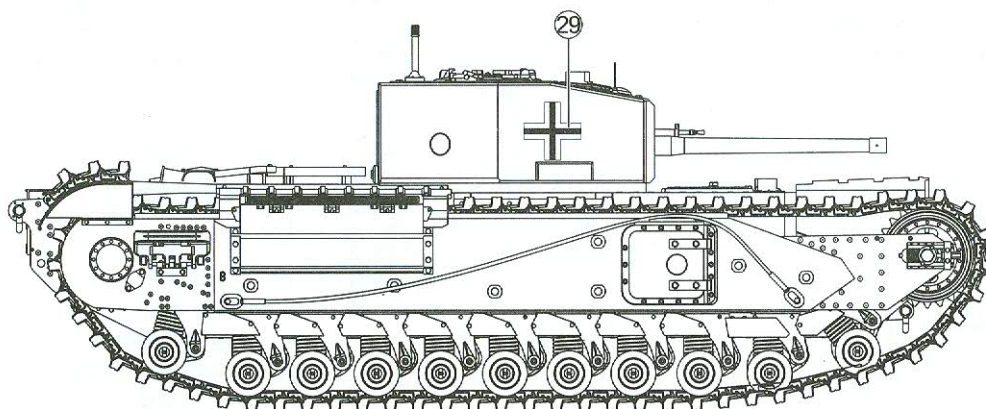
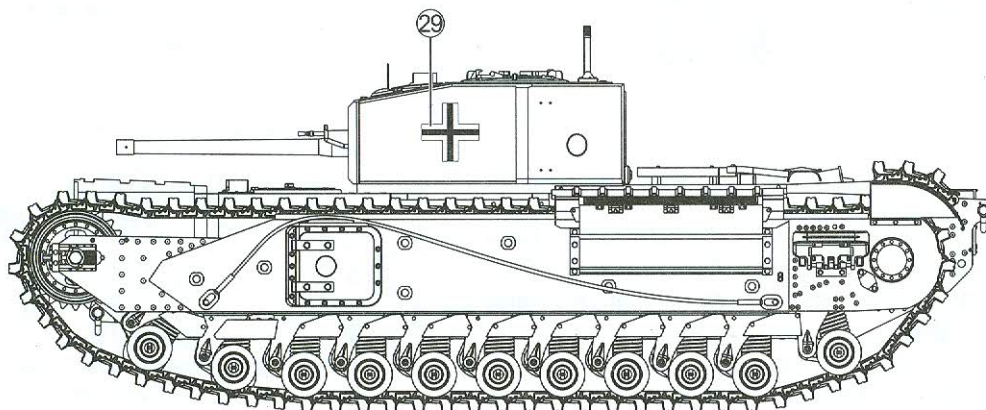

PARTS LIST 零件表

AX1 AF 35153

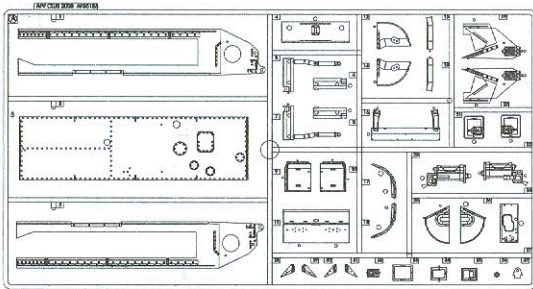

BX1 AF 35153

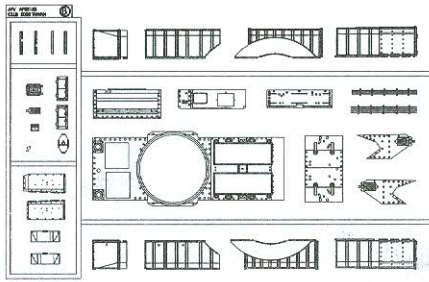

FX1 AF 35153

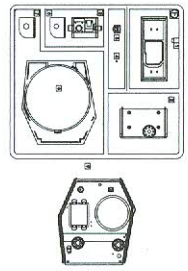

CX1 AF 35153

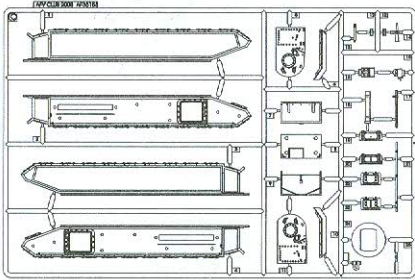

GX1 AF 35176

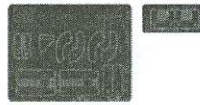

MX1 AF 35176



HX1 AF 35153x1

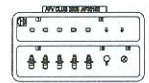

CX1 AF 35153

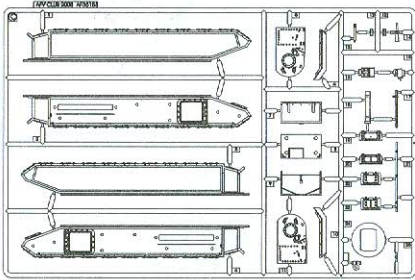

DX2 AF 35153

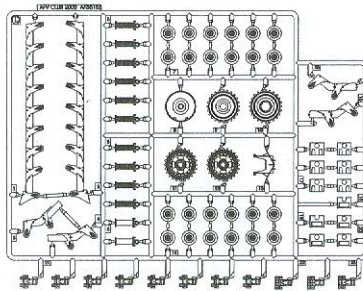

SX1 AF 35176

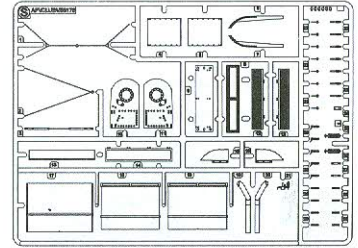

EX2 AF 35153

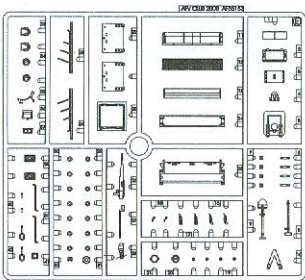

JX1 AF 35176

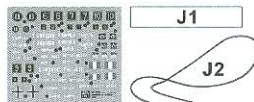

KX22 AF 35153



AX5 AF 35183



Instructions:

If for some reason, you are not fully satisfied or have questions concerning our product; Please use the form provide, and send it to our nearest representative or mail it directly to our office.

We will deal with that A.S.A.P.



AF 35176 Parts Replacement Form

- | | |
|-------------------------------------|-------------------------------------|
| <input type="checkbox"/> AF 35153-A | <input type="checkbox"/> AF 35153-H |
| <input type="checkbox"/> AF 35153-B | <input type="checkbox"/> AF 35176-J |
| <input type="checkbox"/> AF 35153-C | <input type="checkbox"/> AF 35176-M |
| <input type="checkbox"/> AF 35153-D | <input type="checkbox"/> AF 35153-K |
| <input type="checkbox"/> AF 35153-E | <input type="checkbox"/> AF 35176-S |
| <input type="checkbox"/> AF 35153-F | <input type="checkbox"/> AF 35183-A |
| <input type="checkbox"/> AF 35153-G | |

Reason for replacement: Missing
 Broken

Signature: _____

限臺灣地區使用 For Taiwanese use only!



AF 35176 零件補充申請表

申請人
姓名 地址 電話

- | | |
|-------------------------------------|----------|
| <input type="checkbox"/> AF 35153-A | NT\$ 280 |
| <input type="checkbox"/> AF 35153-B | NT\$ 280 |
| <input type="checkbox"/> AF 35153-C | NT\$ 240 |
| <input type="checkbox"/> AF 35153-D | NT\$ 320 |
| <input type="checkbox"/> AF 35153-E | NT\$ 210 |
| <input type="checkbox"/> AF 35153-F | NT\$ 180 |
| <input type="checkbox"/> AF 35176-G | NT\$ 120 |
| <input type="checkbox"/> AF 35153-H | NT\$ 80 |
| <input type="checkbox"/> AF 35176-J | NT\$ 200 |
| <input type="checkbox"/> AF 35153-K | NT\$ 100 |
| <input type="checkbox"/> AF 35176-M | NT\$ 200 |
| <input type="checkbox"/> AF 35176-S | NT\$ 320 |
| <input type="checkbox"/> AF 35183-A | NT\$ 470 |

+郵寄費 NT\$ 80
(請填)總計NT\$ _____

零件補充原因:(請於打)
原包裝即遺失或毀損,
製作途中遺失或毀損,
其他原因 _____

總代理戰鷹企業有限公司收本公司將儘速為您處理。
請將本表與該部品相同金額之郵政匯票一同寄至