

MONOGRAM

KIT 5970

85597000200

JUNKERS JU 88C-6

NIGHT FIGHTER



The role for the JU 88 was dive and high speed level bombing. But as the RLM (German Air Ministry) soon found out, the JU 88 was one of the most versatile aircraft of WWII, close dogfighting being it's only weakness. From the original JU 88, over 100 prototype/variants were produced, which in the modern era is unheard of.

One of these prototype/variants was the night fighter. By mid 1940, with the RAF conducting more and more night bombing missions, there was a call for a new night fighter since the Bf-110 was poorly suited to this role and needed to be replaced. The JU 88C "Zerstörer" (heavy fighter) was a fitting successor to the Bf-110, the JU 88C not only had better endurance and range, it had heavier armament, capacity for four crewmen, and spacious crew areas in comparison to the Bf-110. The JU 88C needed few structural changes to become an effective night fighter. Instead of the glass nose of the JU 88 A bomber version, the C version had a new metal nose with three MG 17 and one MG FF (or MG 151/20) which made concentrated forward fire possible. The original C "Zerstörer" versions of the JU 88, were converted to the C-2, C-4 and C-6 night fighters versions and saw action with various night fighter units. With the introduction of radar, the JU 88C-6 received the first of the FuG 202 Lichtenstein BC radars. Soon the crews called the peculiar radar antennas "Matratzen" (Mattresses) because of their square,boxy design. A total of 3964 destroyers and night fighters were built under JU 88C series.

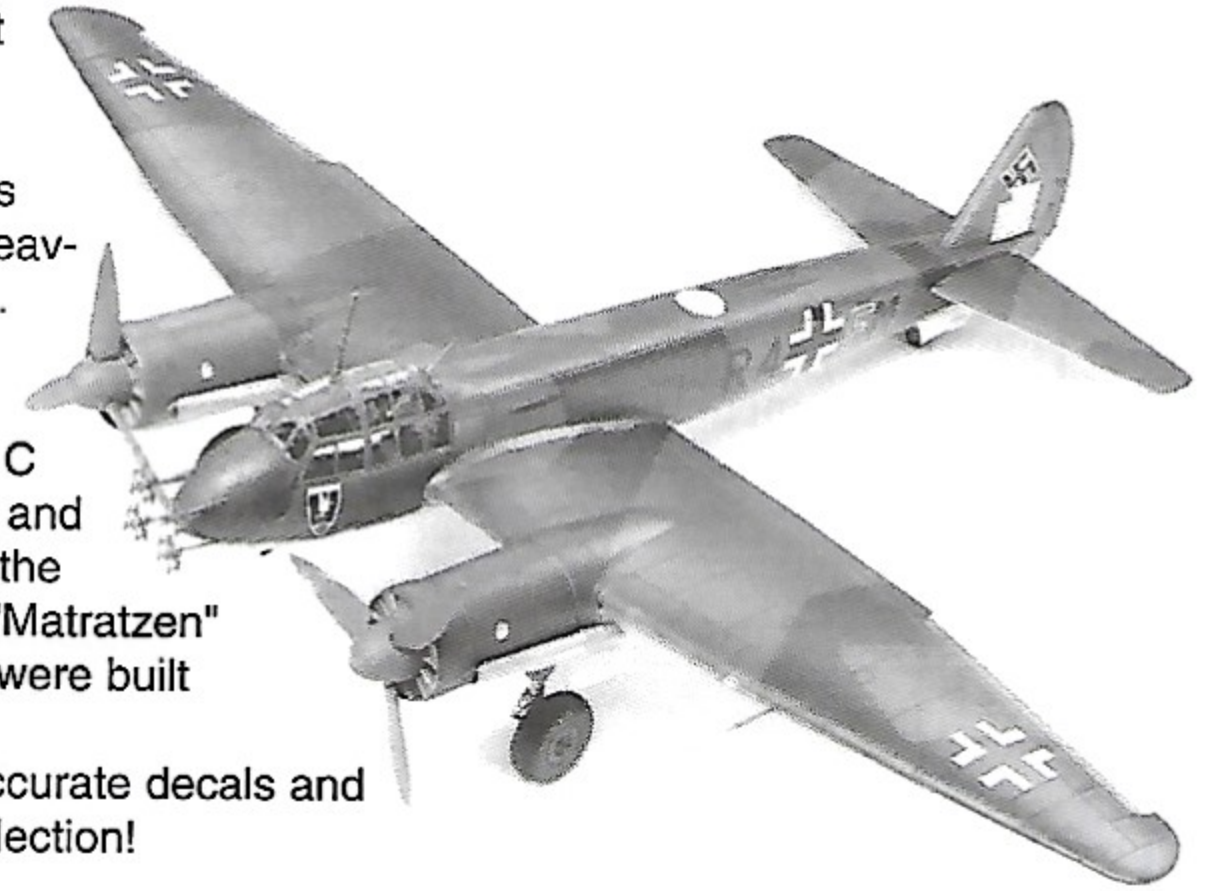

Your revell kit includes high quality injected molded plastic of the JU 88C-6 version, accurate decals and markings, a detailed painting guide is also included to make this JU 88C-6 a standout in any collection!



* REPEAT SEVERAL TIMES
* A REPETER PLUSIEURS FOIS



* OPTIONAL PARTS
* PIECES EN OPTION



* DECAL
* DECAL COMANIE



* MODELING TIPS AND NOTES
* MODELANT POINTES ET NOTES



* REMOVE AND THROW AWAY
* A RETIRER ET JETER



* DO NOT CEMENT
* NE PAS COLLER



* OPEN HOLE
* TROU OUVERT

READ THIS BEFORE YOU BEGIN

- * Study the assembly drawings.
- * Each plastic part is identified by a number.
- * In the assembly drawings, some parts will be marked by a star (★) to indicate chrome plated plastic.
- * For better paint and decal adhesion, wash the plastic parts in a mild detergent solution. Rinse and let air dry.
- * Check the fit of each piece before cementing in place.
- * Use only cement for polystyrene plastic.
- * Scrape plating and paint from areas to be cemented.
- * Allow paint to dry thoroughly before handling parts.
- * Any unused parts may be discarded.

DECAL APPLICATION INSTRUCTIONS

1. Cut desired decal from sheet.
2. Dip decal in water for a few seconds.
3. Place wet decal on paper towel.
4. Wait until decal is movable on paper backing.
5. Place decal in position on model, face up and slide backing away.
6. Press out air bubbles with a soft damp cloth.
7. Milkyness that may appear is for better decal adhesion and will dry clear. Wipe away any excess adhesive.
8. Do not touch decal until fully dry.
9. Allow the decals 48 hours to dry before applying clear coat.

NOTE: Decals are compatible with setting solutions or solvents.

LIRE CE QUI SUIT AVANT DE COMMENCER

- * Etudier les schémas de montage.
- * Chaque pièce en plastique est identifiée par un numéro.
- * Sur les schémas de montage, certaines pièces sont marquées d'une étoile (★) pour indiquer qu'elles sont en plastique chromé.
- * Pour une meilleure prise de la peinture et des autocollants, laver les pièces en plastique avec une solution détergente peu concentrée. Les rincer et les laisser sécher à l'air.
- * Vérifier que chaque pièce s'ajuste bien avant de la coller en place.
- * N'utiliser que de la colle pour polystyrène.
- * Gratter les parties à coller pour enlever le chrome et la peinture.
- * Laisser la peinture bien sécher avant de manipuler les pièces.
- * Toute pièce inutilisée peut être jetée.

DIRECTIVES D'APPLICATION DES AUTOCOLLANTS

1. Découper l'autocollant désiré de la feuille.
2. Tremper l'autocollant dans de l'eau pendant quelques secondes.
3. Placer l'autocollant mouillé sur une serviette en papier.
4. Attendez que l'autocollant puisse être déplacé sur son support en papier.
5. Mettre l'autocollant en position sur le modèle face sur le dessus et faire glisser le support pour l'enlever.
6. Appuyer avec un chiffon doux humide pour éliminer les bulles d'air.
7. La substance laiteuse qui peut apparaître est destinée à améliorer l'adhésion de l'autocollant et devient incolore au séchage. Essuyer pour enlever tout excédent d'adhésif.
8. Ne pas toucher l'autocollant tant qu'il n'est pas bien sec.
9. Laisser l'autocollant sécher pendant 48 heures avant d'appliquer une couche transparente.

REMARQUE: Les autocollants sont compatibles avec les solutions de fixation ou les solvants.

This paint guide is provided to complete this kit as shown on the box.

Ce guide de peinture est fourni pour reproduire le modèle réduit qui apparaît sur la boîte.

Black Gray	RLM 66	<i>Gris noir</i>
Black Green	RLM 70	<i>Vert noir</i>
Dark Green	RLM 71	<i>Vert foncé</i>
Dark Gray	RLM 74	<i>Gris foncé</i>
Flat Black		<i>Noir mat</i>
Flat White		<i>Blanc mat</i>
Gray	RLM 02	<i>Gris</i>
Gray	RLM 76	<i>Gris</i>
Gunmetal		<i>Bronze</i>
Light Blue	RLM 65	<i>Bleu clair</i>
Sand	RLM 79	<i>Sable</i>
Silver		<i>Argent</i>
Steel		<i>Acier</i>

If you have any questions or comments, call our hotline at: **(800) 833-3570**
or, please write to:

Revell-Monogram Consumer Service Department, 8601 Waukegan Road, Morton Grove, Illinois 60053

Be sure to include the plan number (85597000200), part number, description, your return address and phone number.

Visit our website: www.revell-monogram.com

COCKPIT ASSEMBLY

PAINTING NOTE: PAINT ALL COCKPIT PARTS DARK GRAY RLM 66 BEFORE ASSEMBLY AS NOTED. THE INSTRUMENT PANEL AND SOME OF THE PANELS ON THE SIDE CONSOLES WERE FLAT BLACK. DETAILS ON THE INSTRUMENT PANEL WERE FLAT WHITE OR A VERY PALE YELLOW.

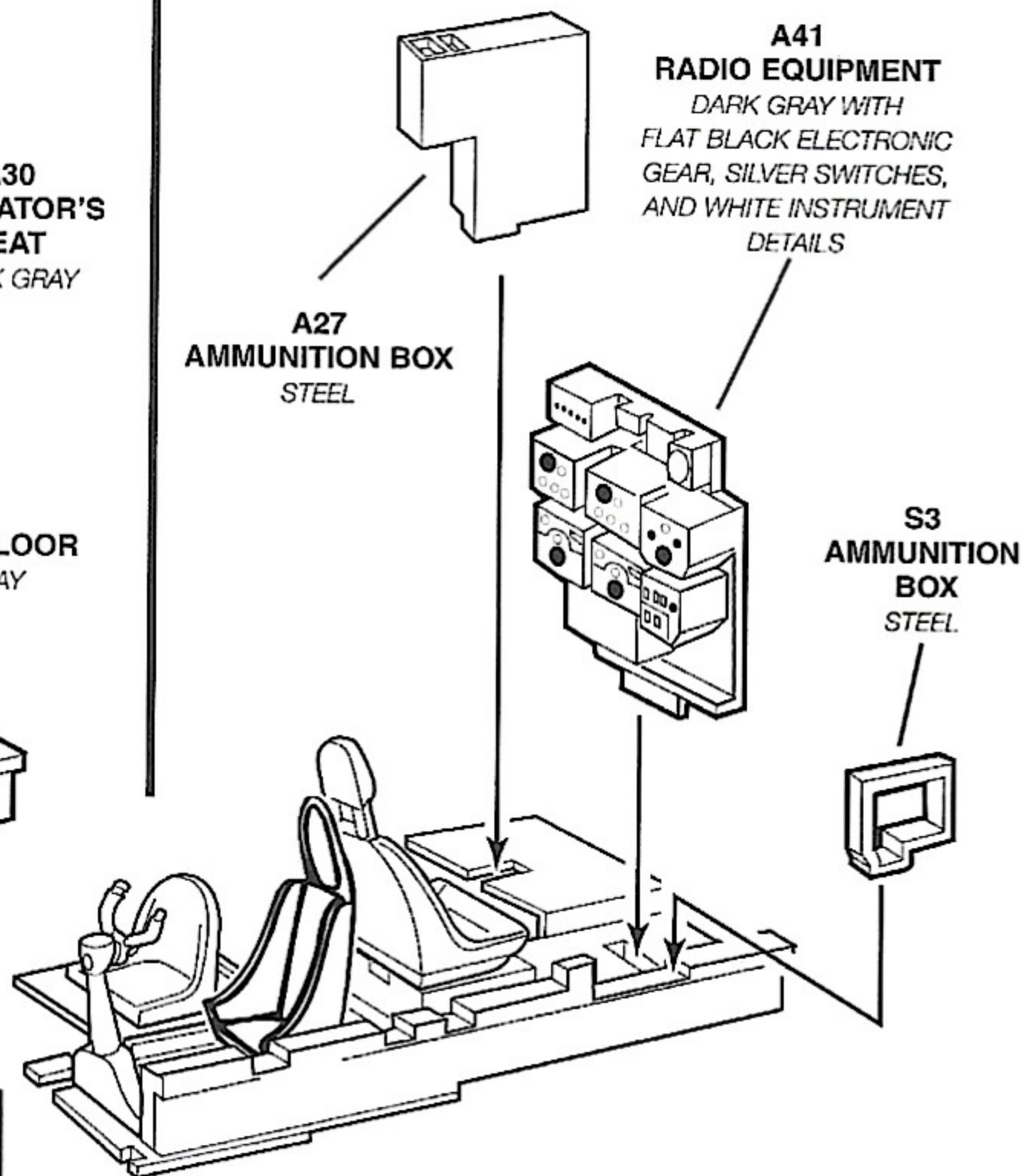
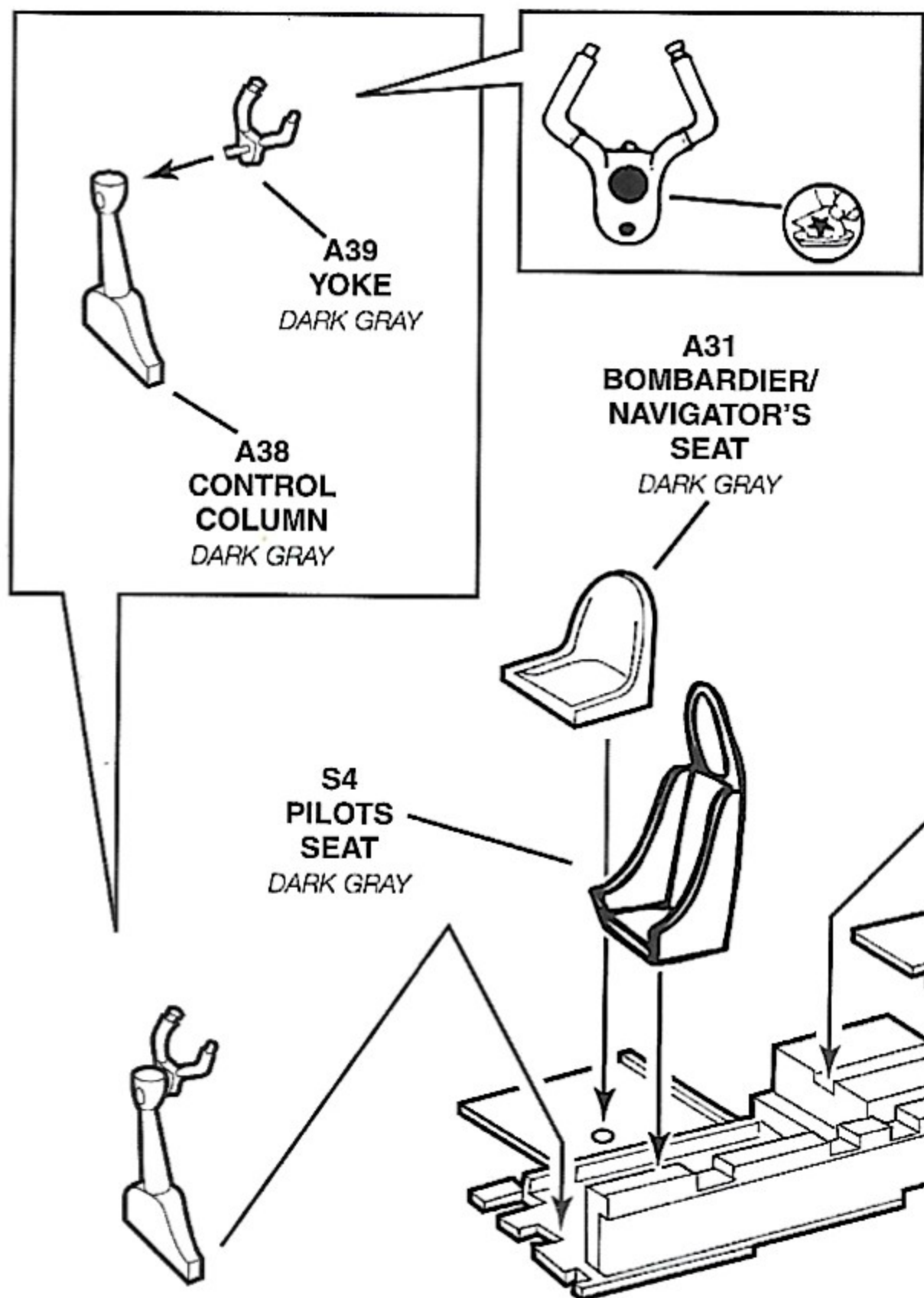

PAINTING NOTE: RUN SOME LIGHT GRAY WASH AROUND THE COCKPIT DETAILS AFTER THE BASIC DARK GRAY RLM 66, PAINT IS COMPLETELY DRY. THIS WILL MAKE THE DETAILS STAND OUT BETTER AFTER THE MODEL IS ASSEMBLED, AND IT WILL ALSO ADD A WEATHERED APPEARANCE. USING SOME FLAT BLACK WASH IN SOME AREAS WILL ALSO ADD TO THE EFFECT.

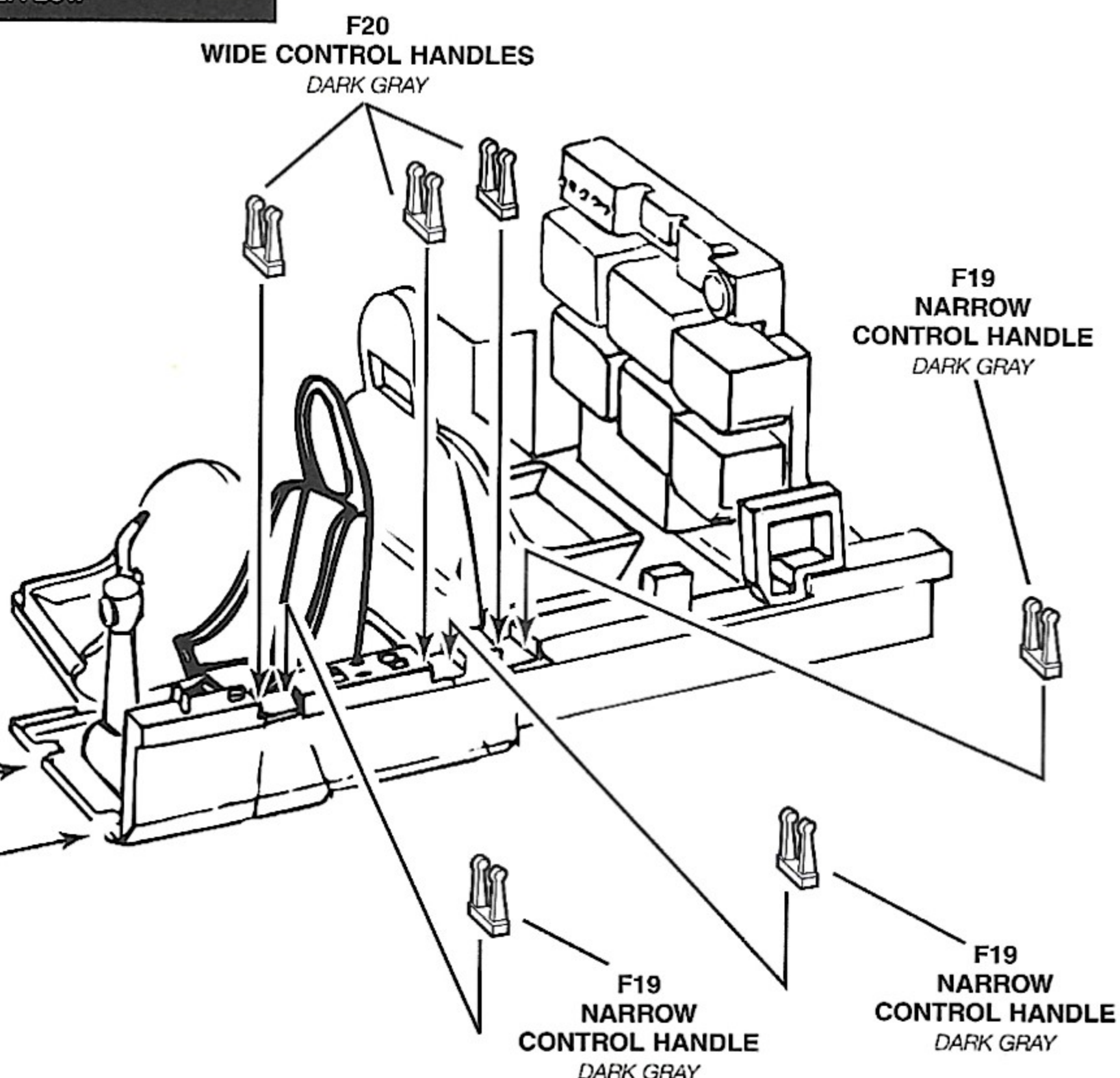
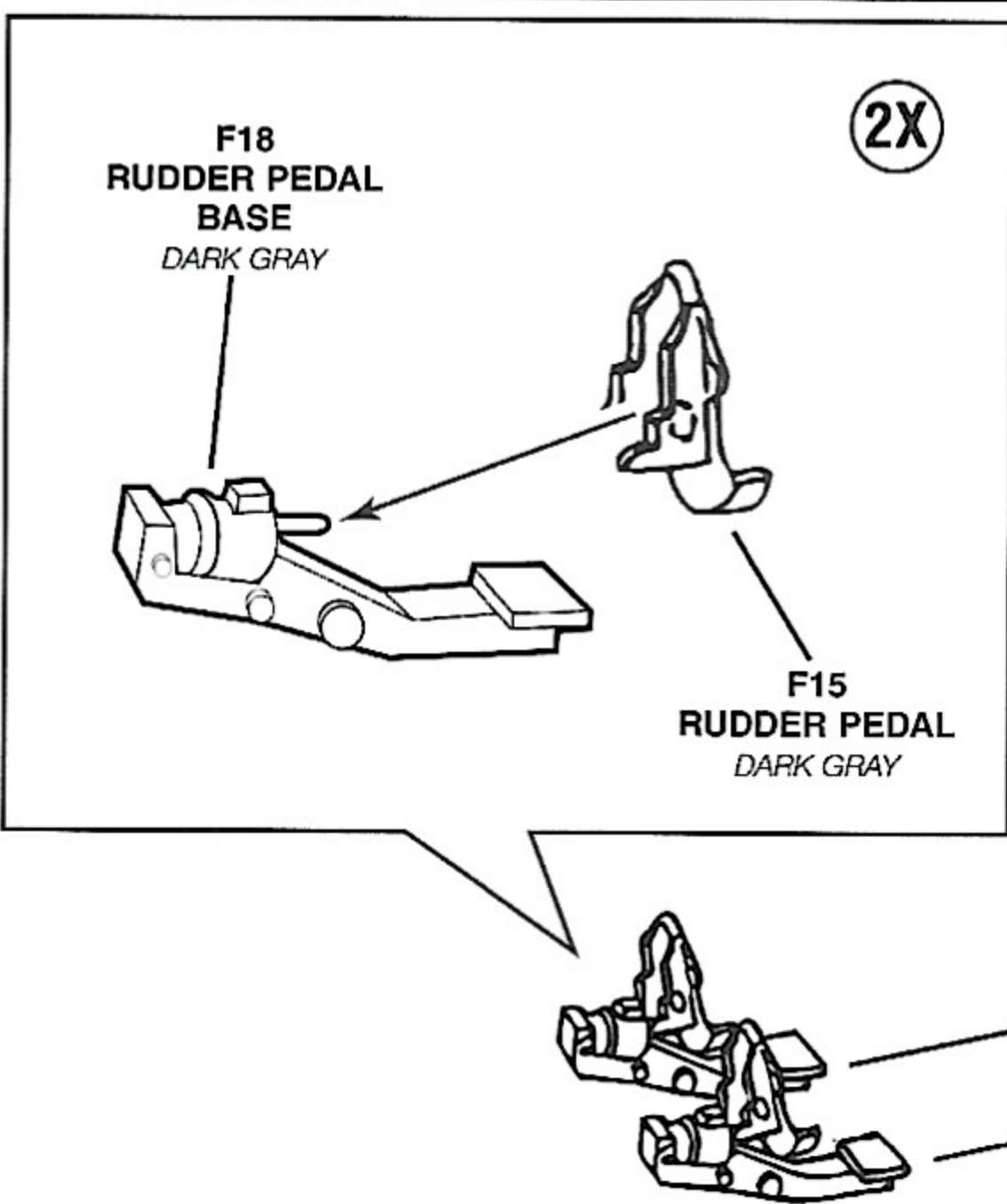

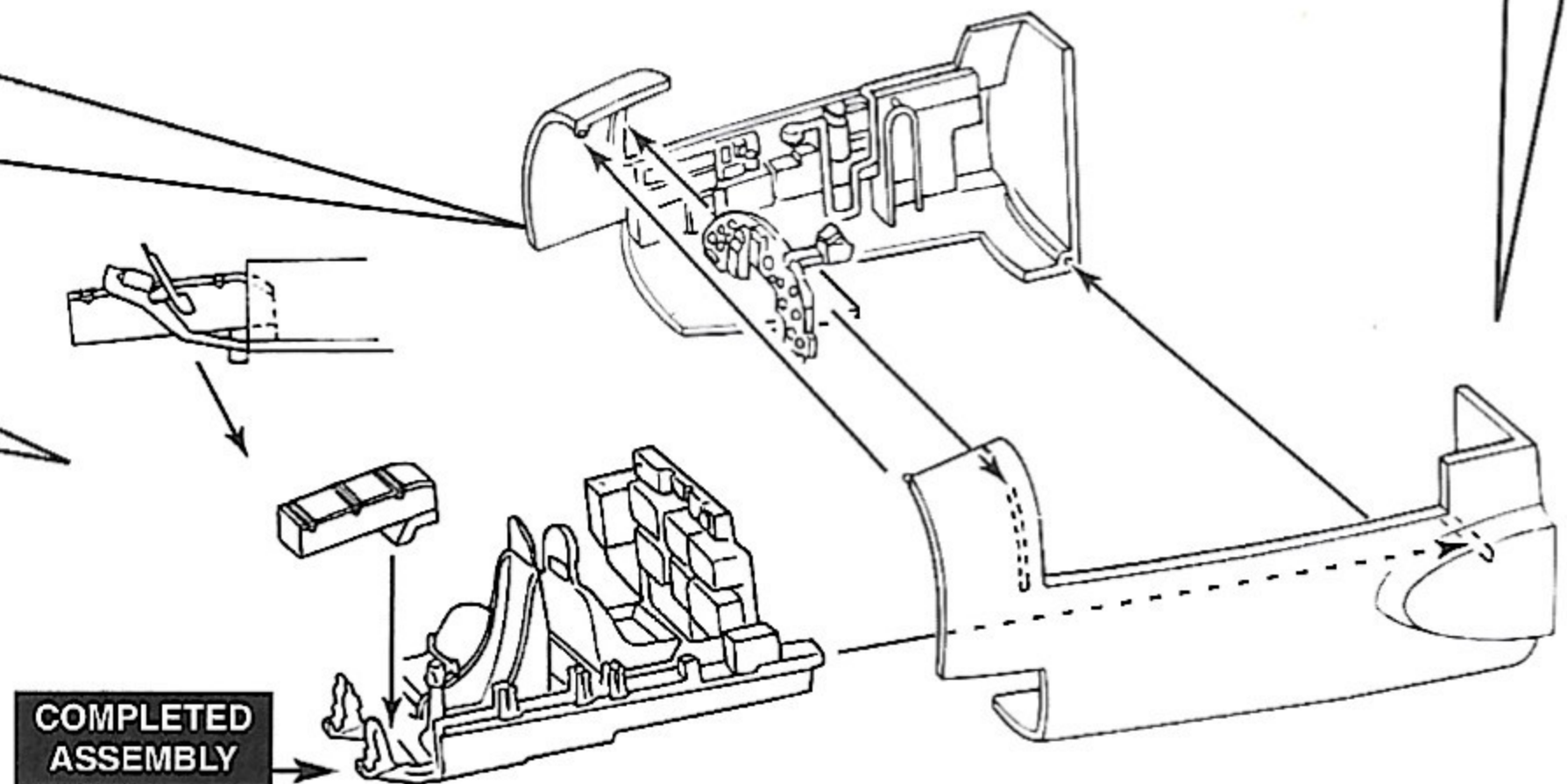
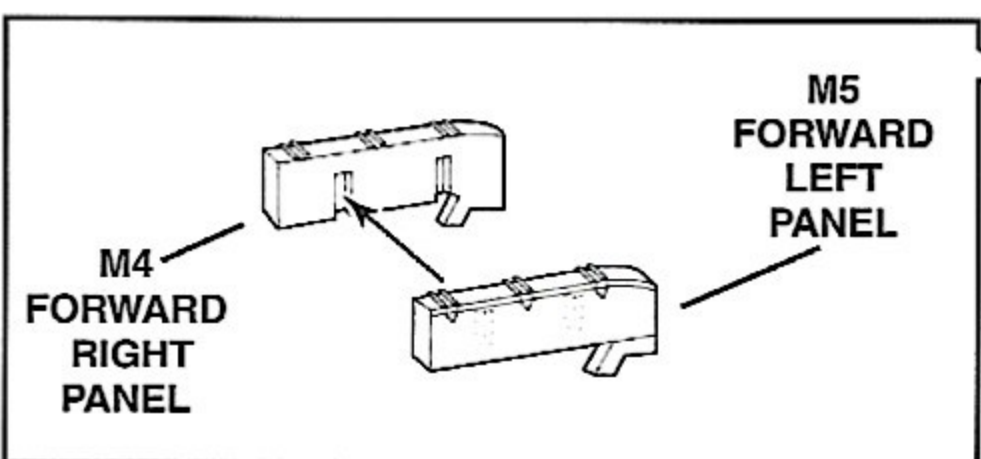
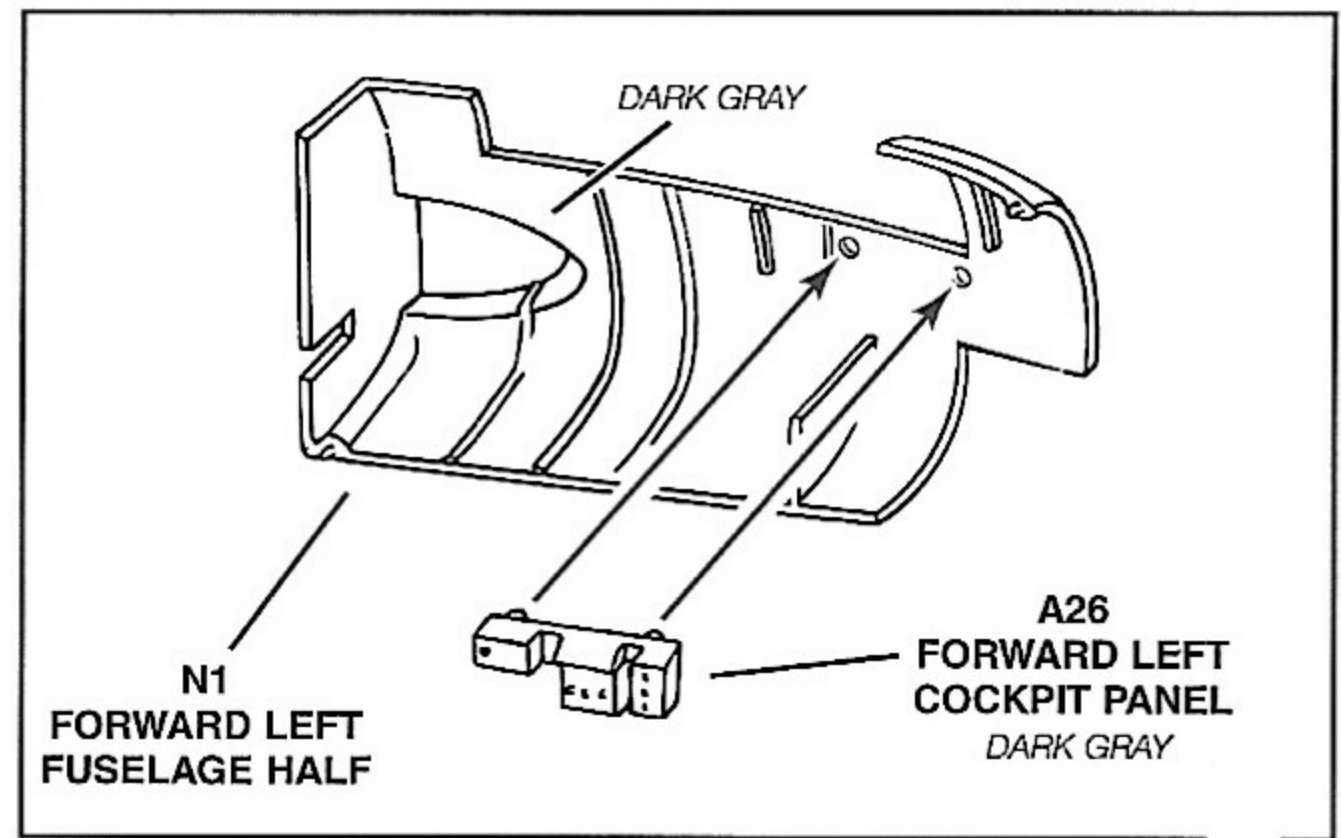
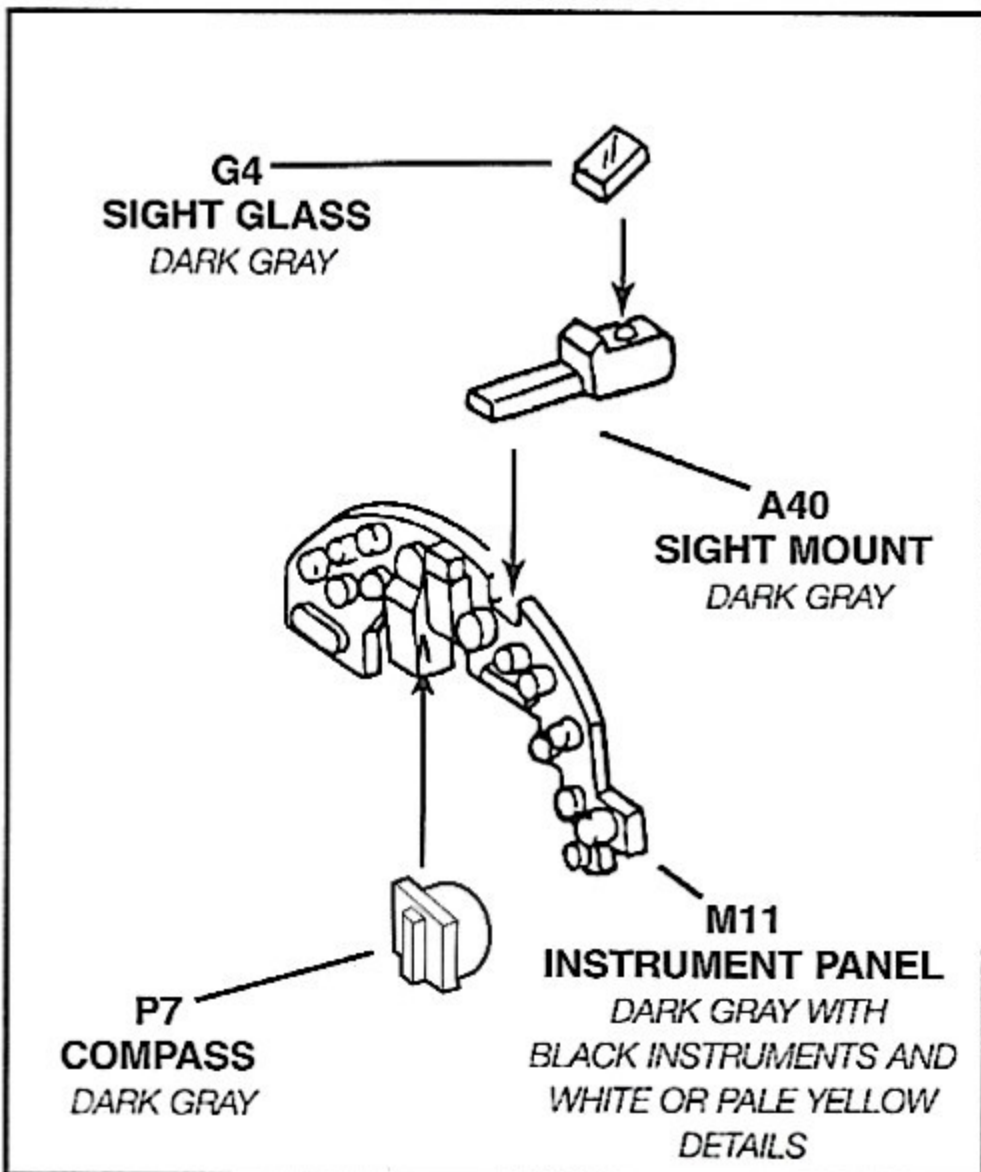
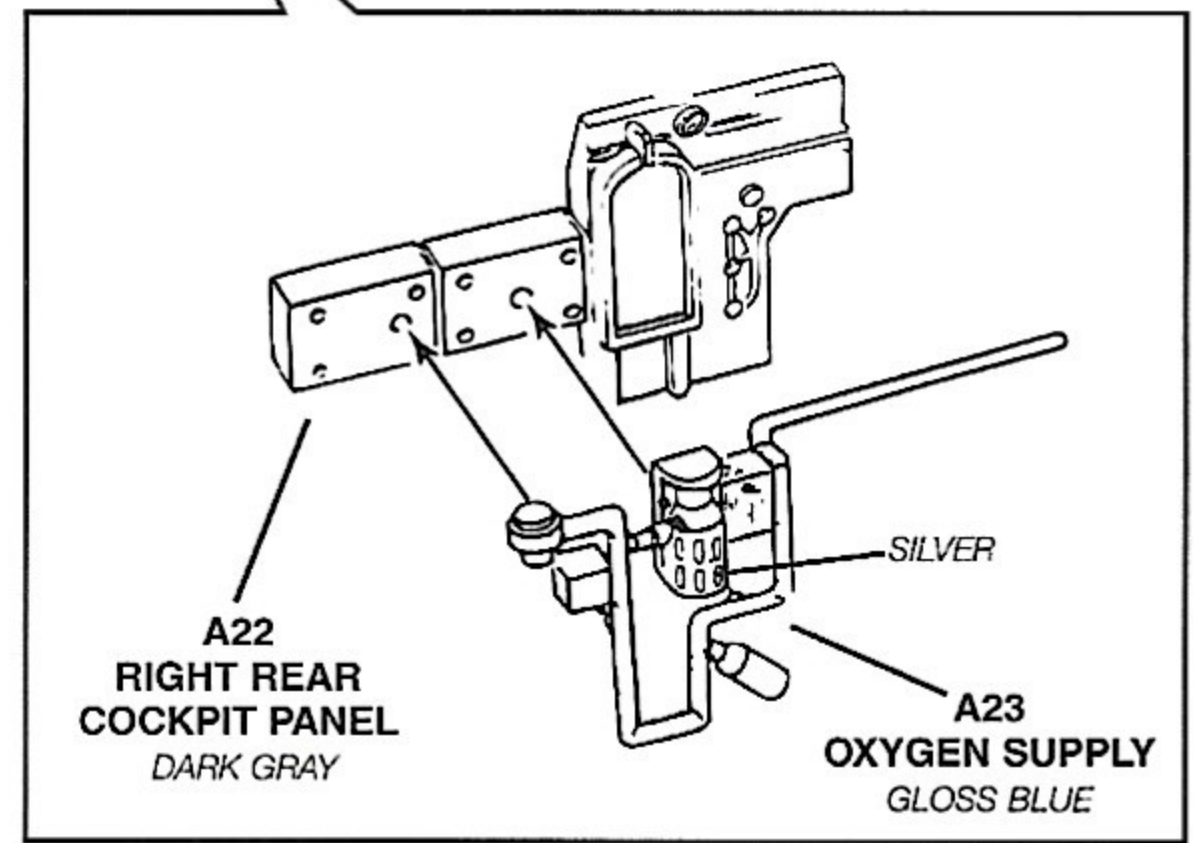
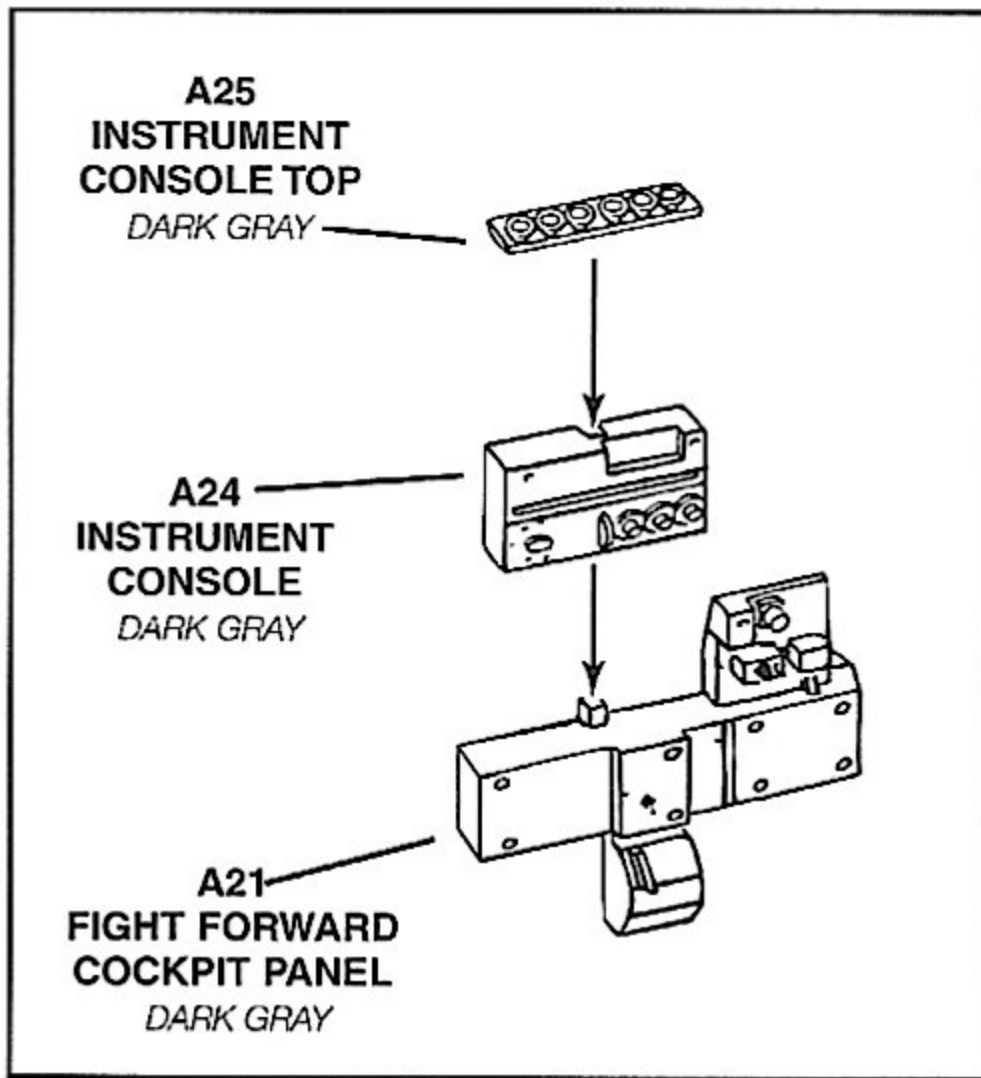
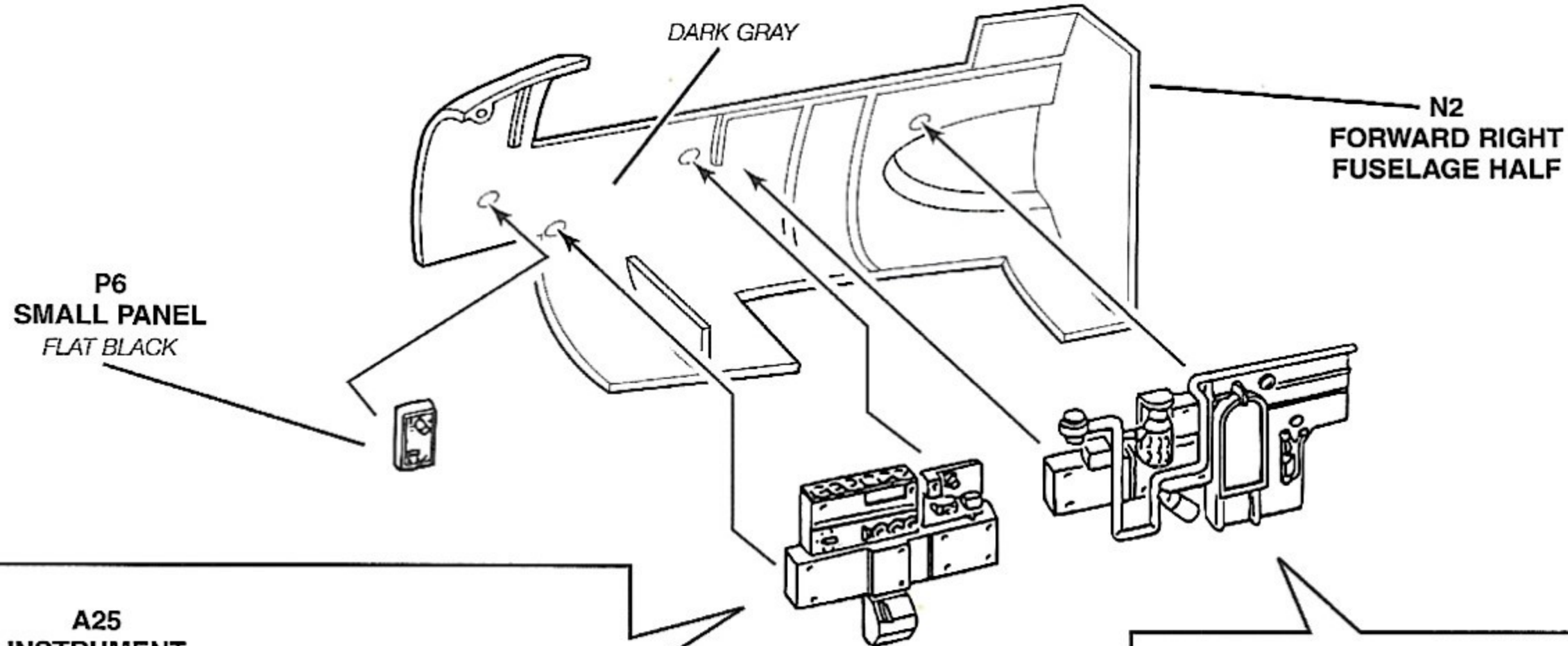

NOTE: INSTEAD OF USING (Z2) DIRECTION FINDER, YOU CAN USE THE DECAL 33, DO NOT REMOVE DECAL FROM BACKING. MOUNT THE DECAL TO THE INSIDE AREA OF THE DIRECTION FINDER COVER USING WHITE GLUE

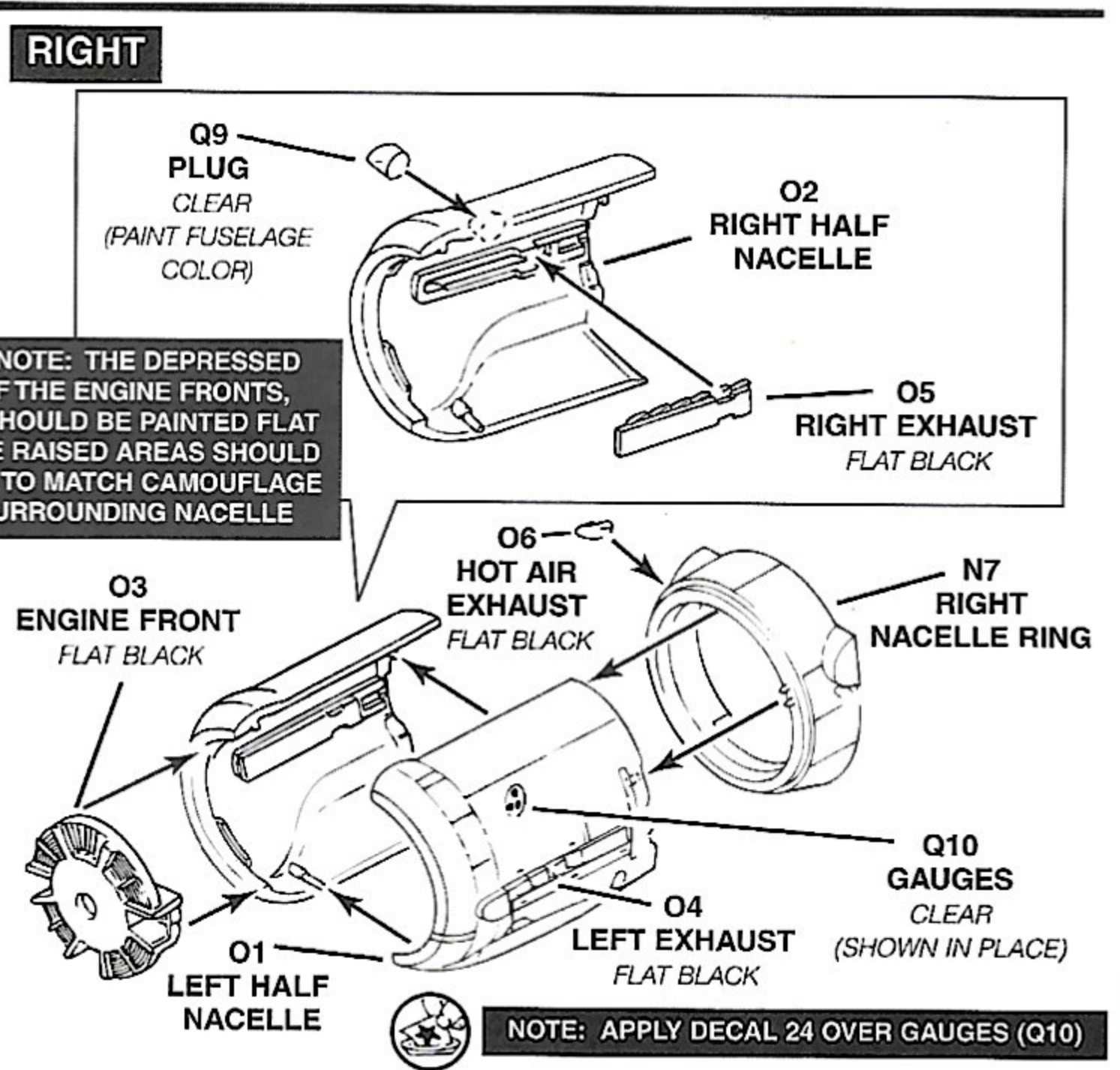
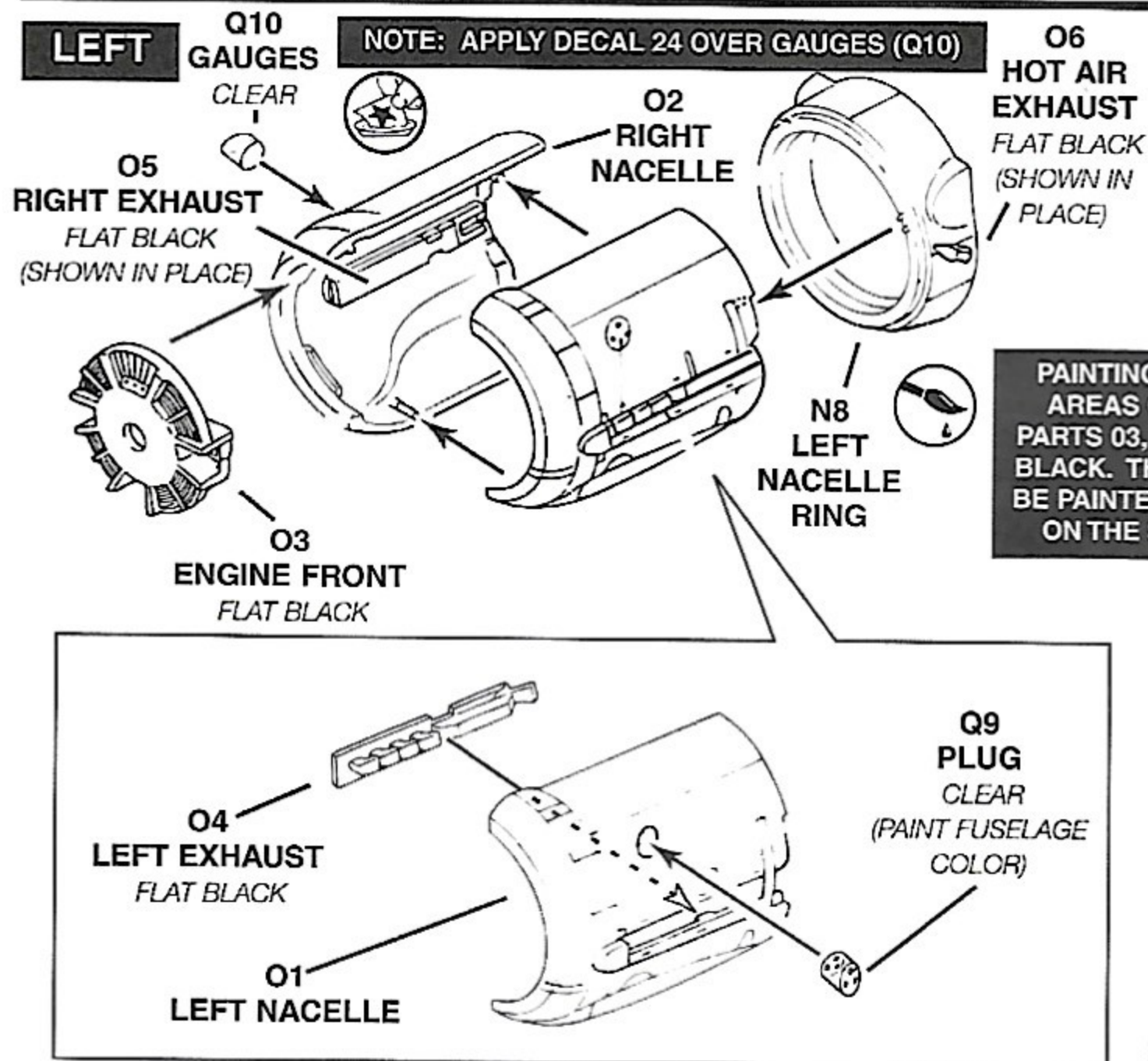
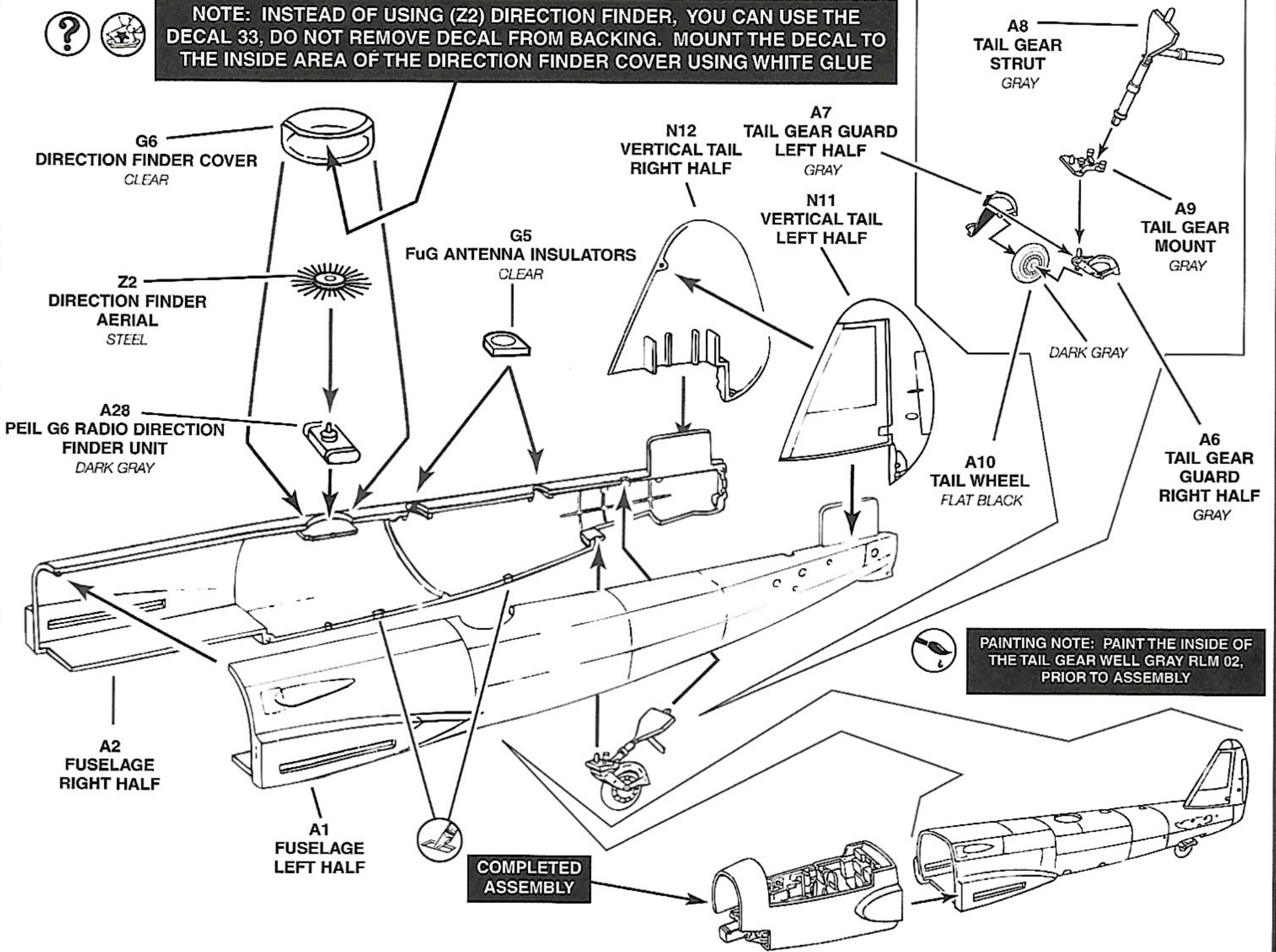

PAINTING NOTE: THE DEPRESSED AREAS OF THE ENGINE FRONTS, PARTS 03, SHOULD BE PAINTED FLAT BLACK. THE RAISED AREAS SHOULD BE PAINTED TO MATCH CAMOUFLAGE ON THE SURROUNDING NACELLE

WING ASSEMBLY

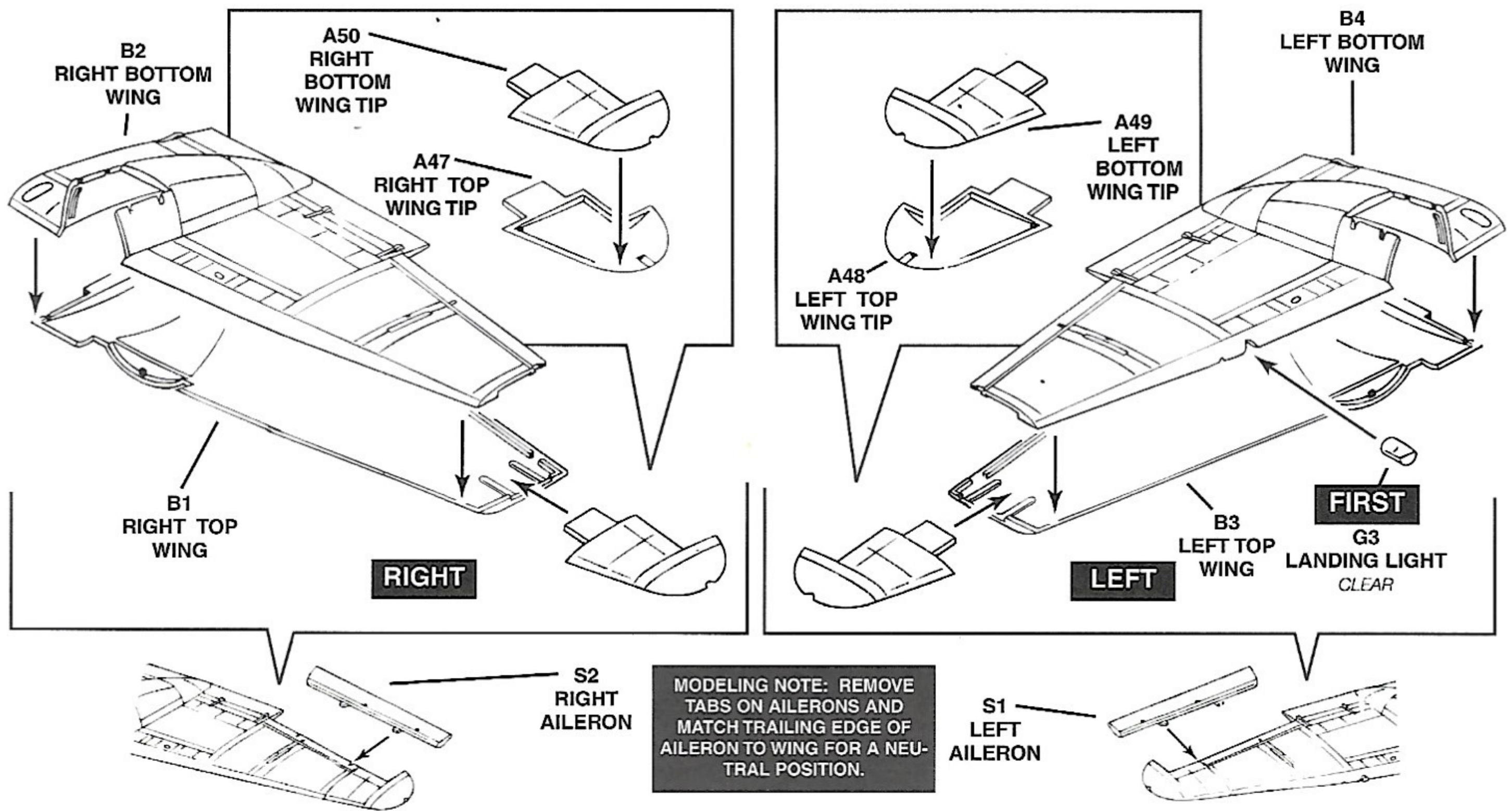

RIGHT WING

PAINTING NOTE: THE LANDING GEAR STRUTS AND WHEEL WELLS WERE USUALLY DIRTY AND GREASY. THIS CAN BE SIMULATED WITH SOME BLACK AND BROWN WASHES ON THE PARTS. BECAUSE GERMAN AIRCRAFT OFTEN OPERATED FROM DIRT OR GRASS FIELDS DURING WWII, THE TIRES OFTEN HAD DIRT AND MUD ON THEM. SIMULATE THIS WITH DIRTY BROWN AND GRAY WASHES

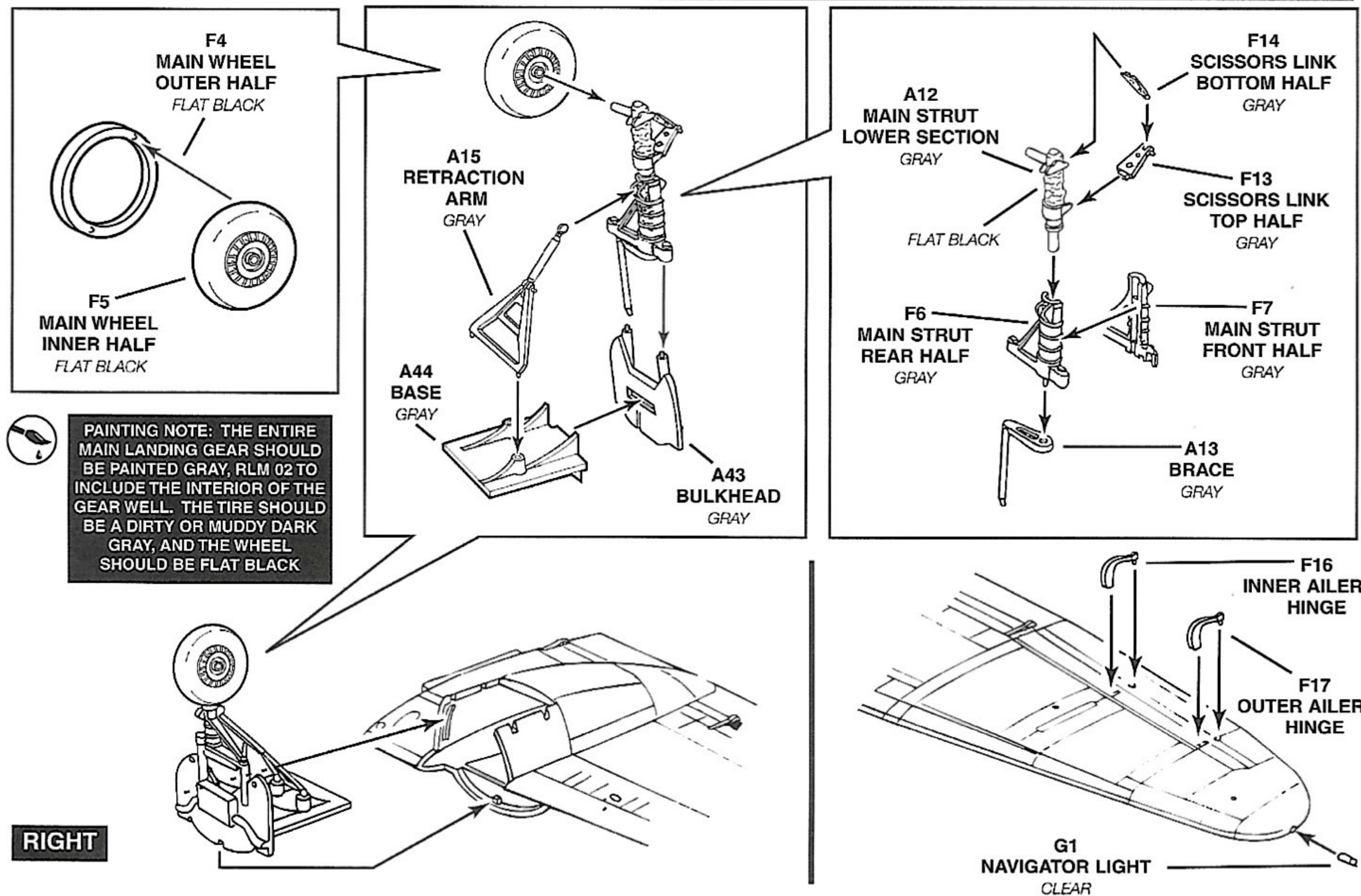

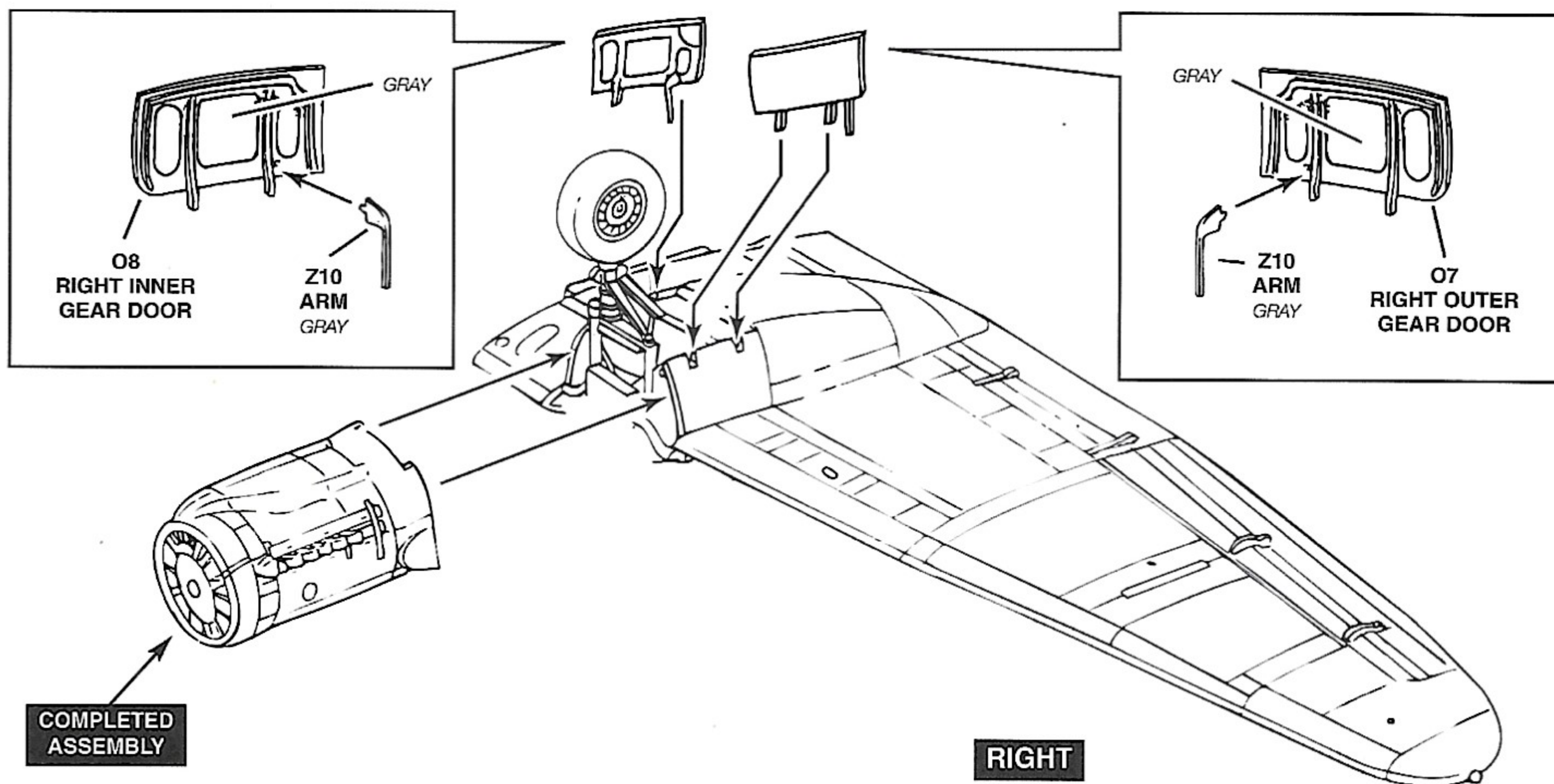

LEFT WING



PAINTING NOTE: THE LANDING GEAR STRUTS AND WHEEL WELLS WERE USUALLY DIRTY AND GREASY. THIS CAN BE SIMULATED WITH SOME BLACK AND BROWN WASHES ON THE PARTS. BECAUSE GERMAN AIRCRAFT OFTEN OPERATED FROM DIRT OR GRASS FIELDS DURING WWII, THE TIRES OFTEN HAD DIRT AND MUD ON THEM. SIMULATE THIS WITH DIRTY BROWN AND GRAY WASHES

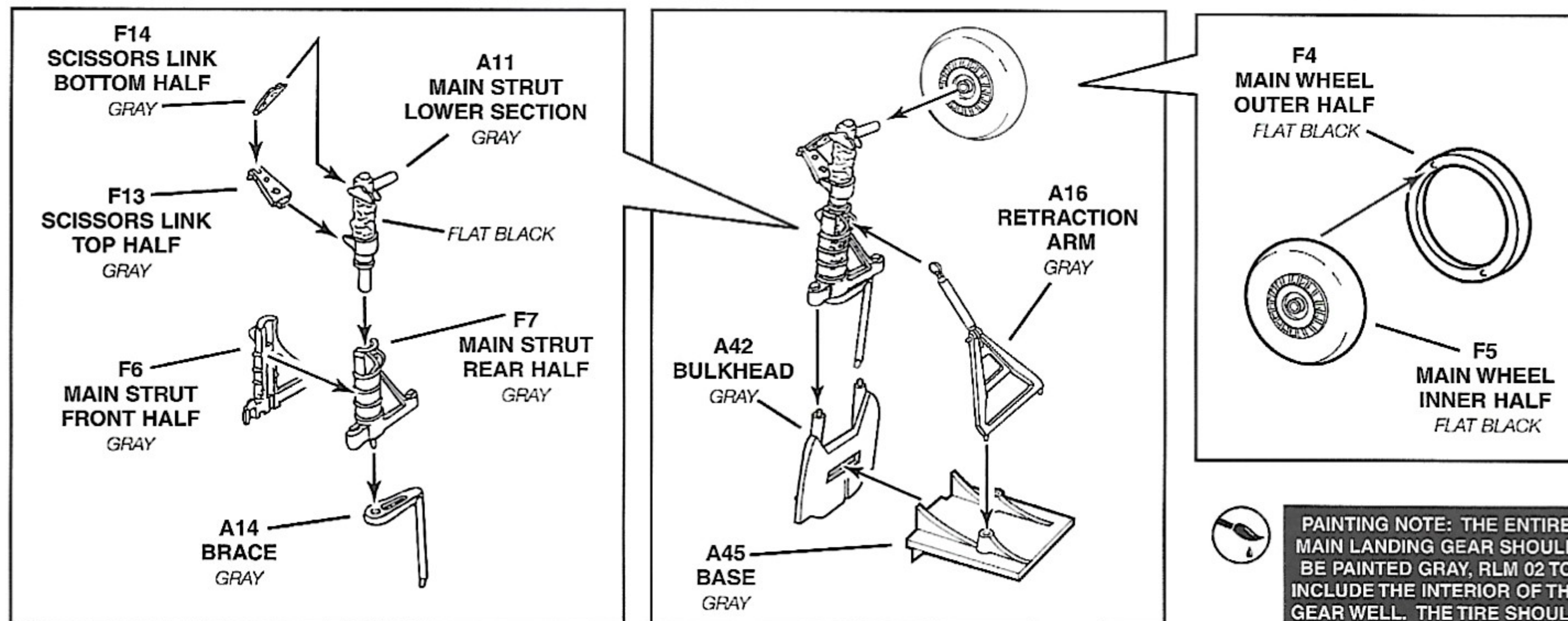

PAINTING NOTE: THE ENTIRE MAIN LANDING GEAR SHOULD BE PAINTED GRAY, RLM 02 TO INCLUDE THE INTERIOR OF THE GEAR WELL. THE TIRE SHOULD BE A DIRTY OR MUDDY DARK GRAY, AND THE WHEEL SHOULD BE FLAT BLACK

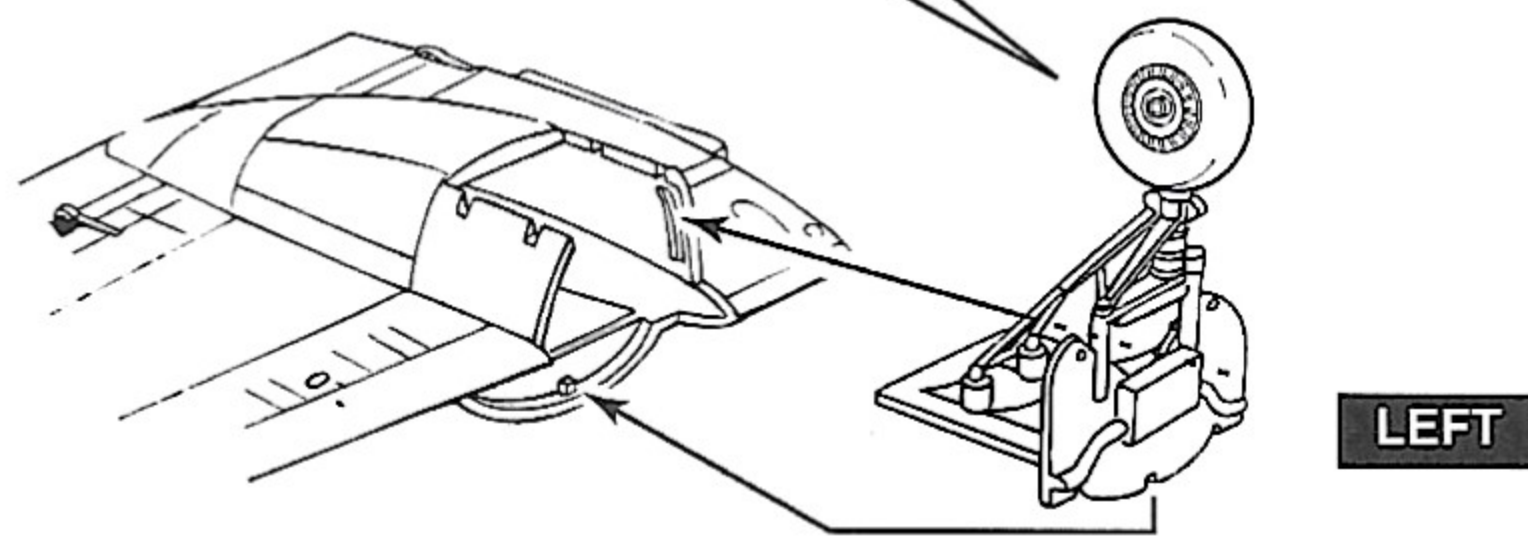
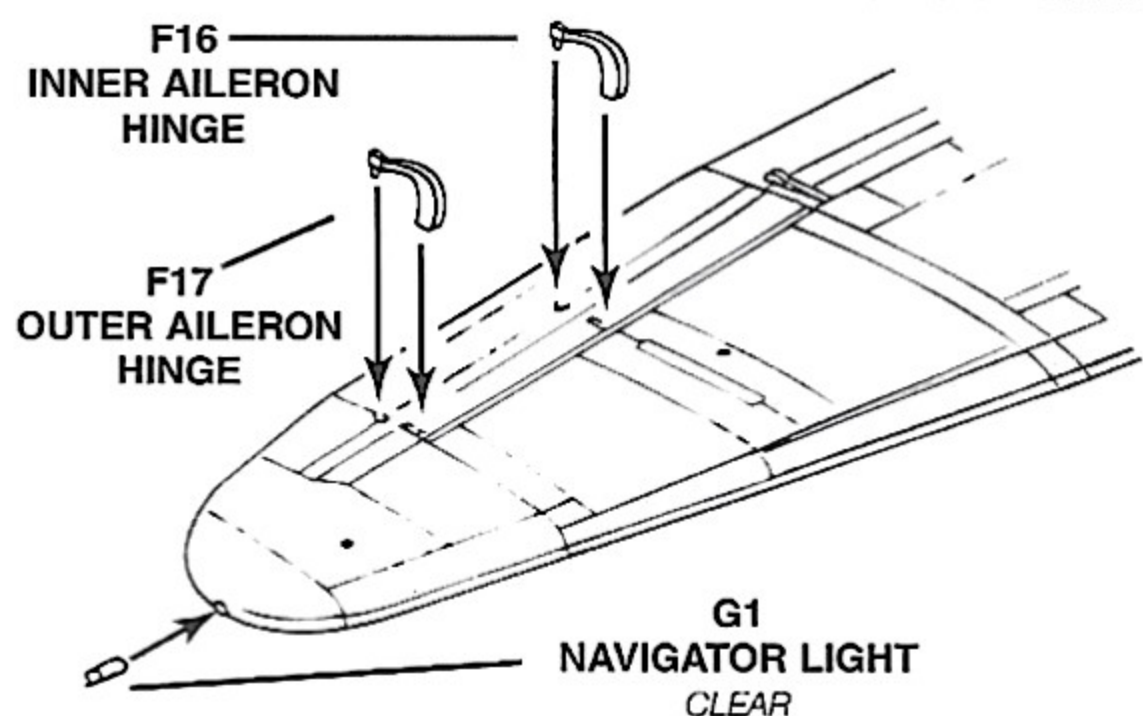

3

WING ASSEMBLY CONTINUED

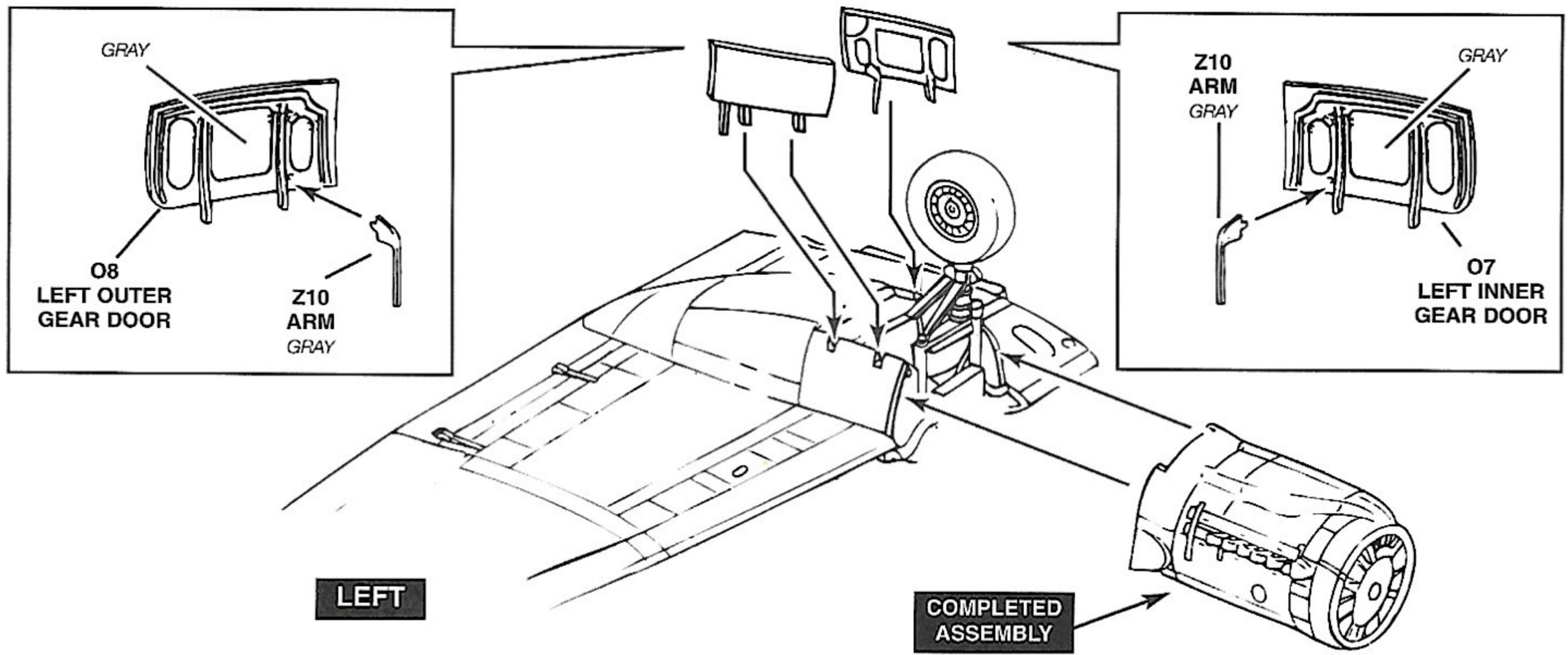

4

TAIL ASSEMBLY

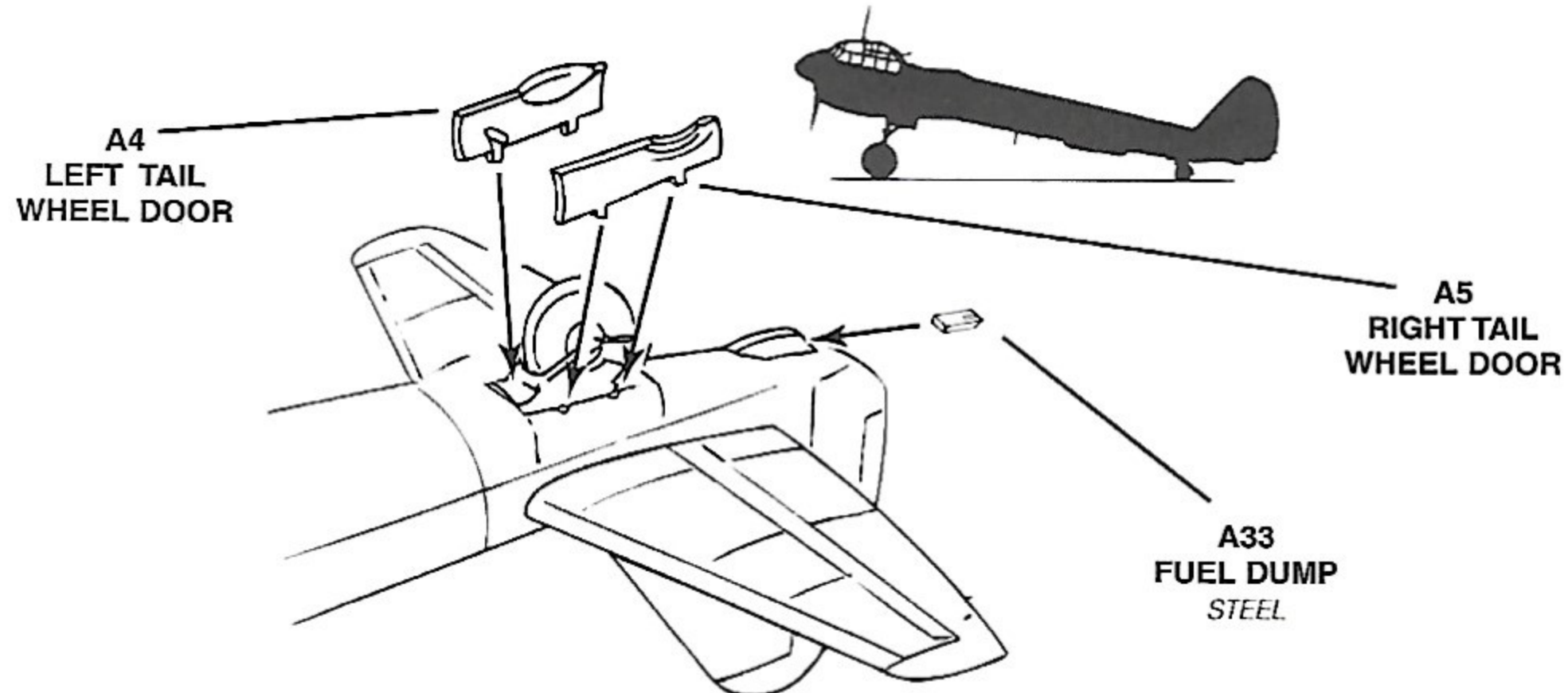
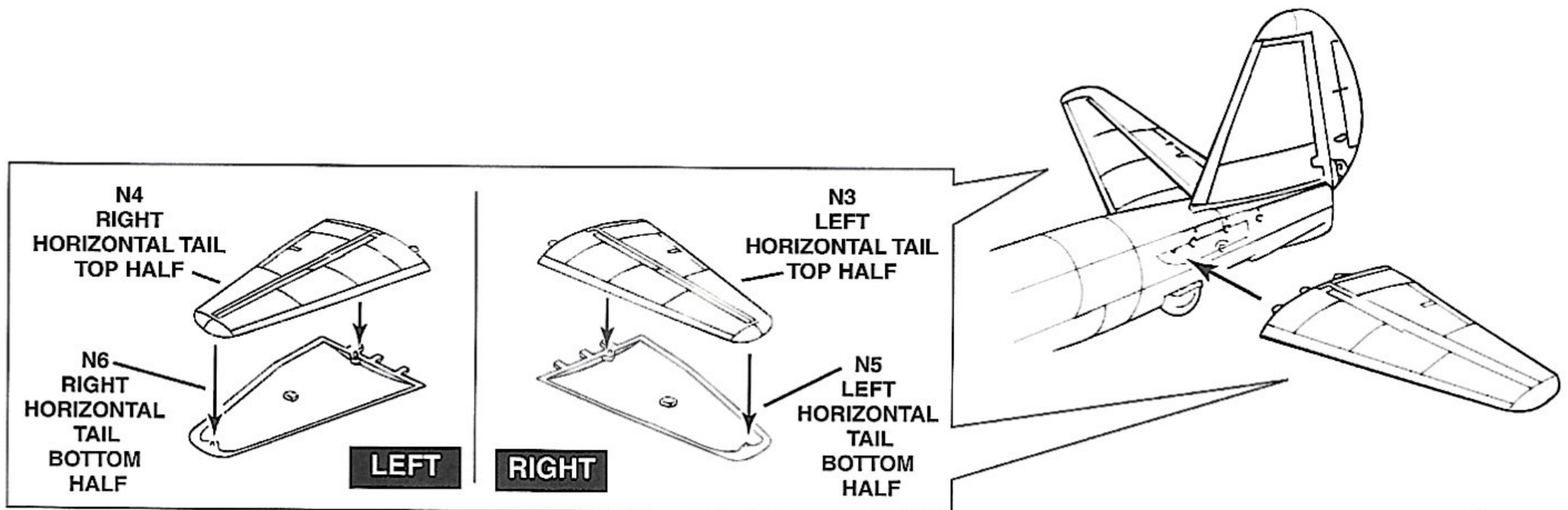

5

EXHAUST VENTS ASSEMBLY

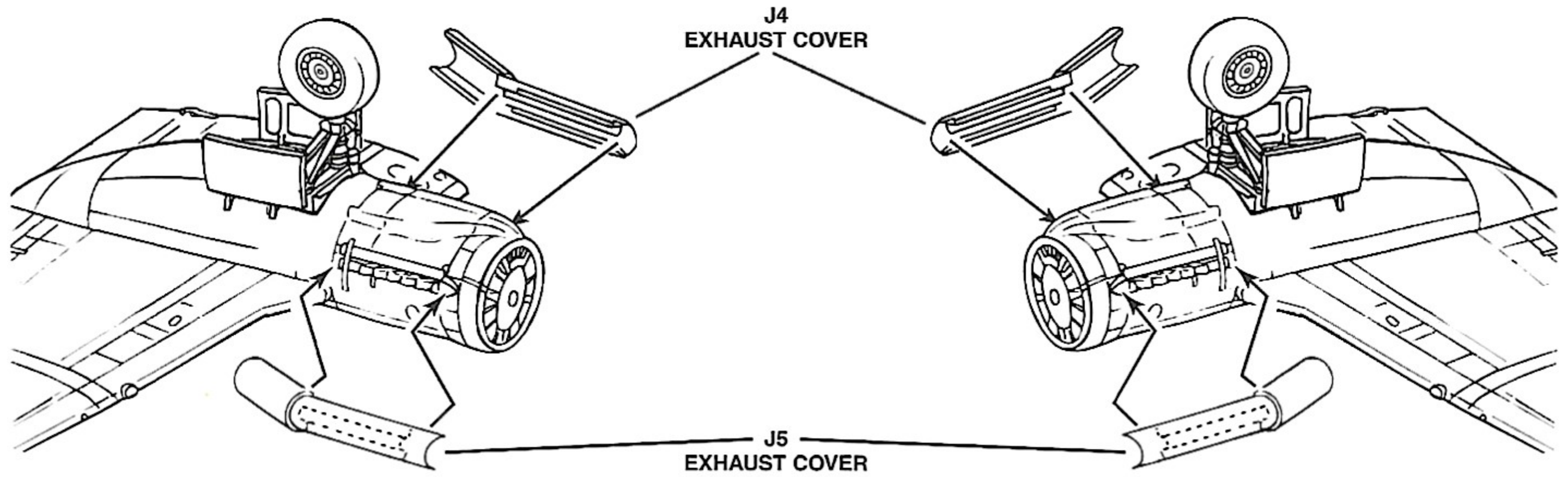

6

PROPELLER ASSEMBLY

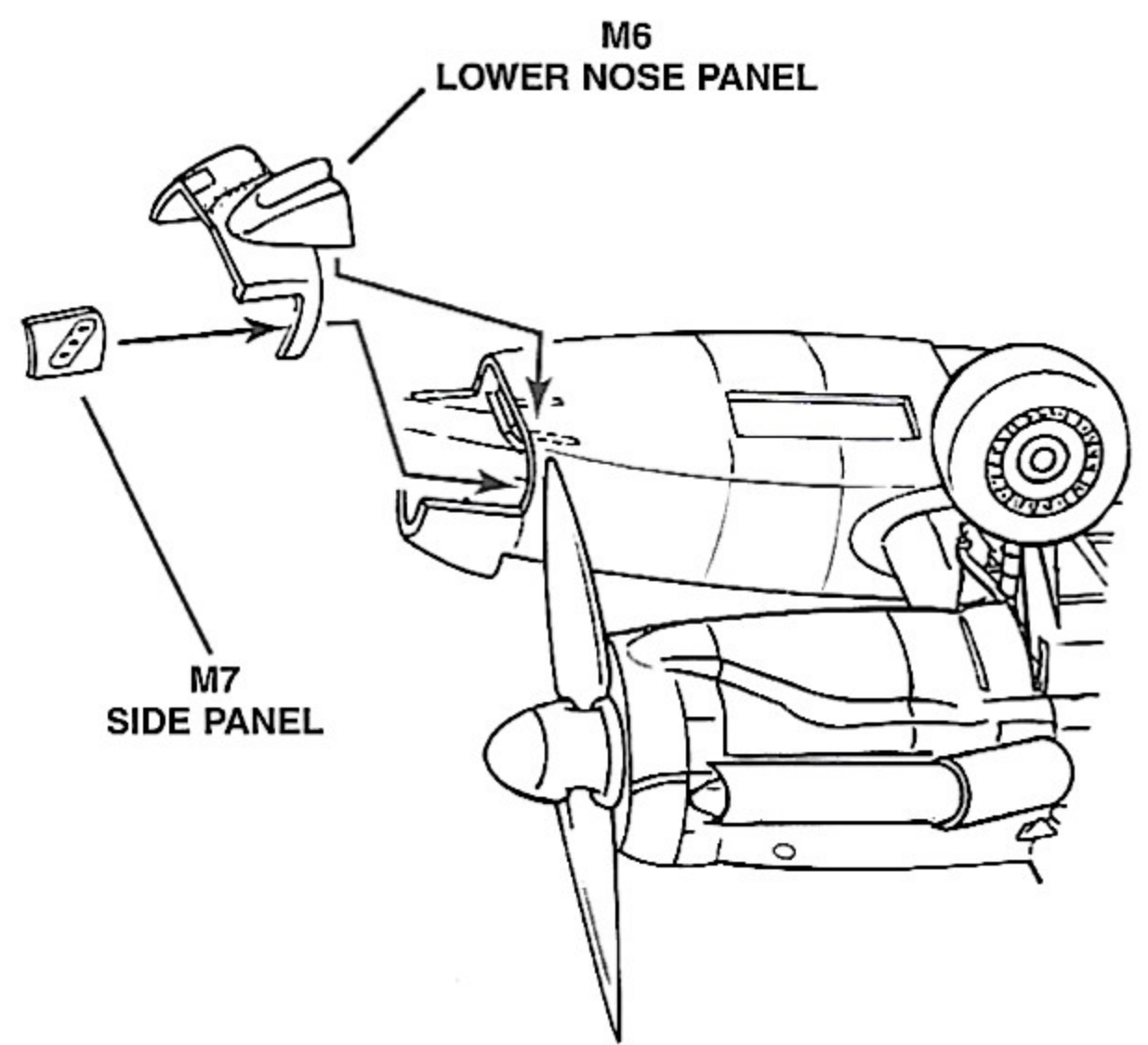
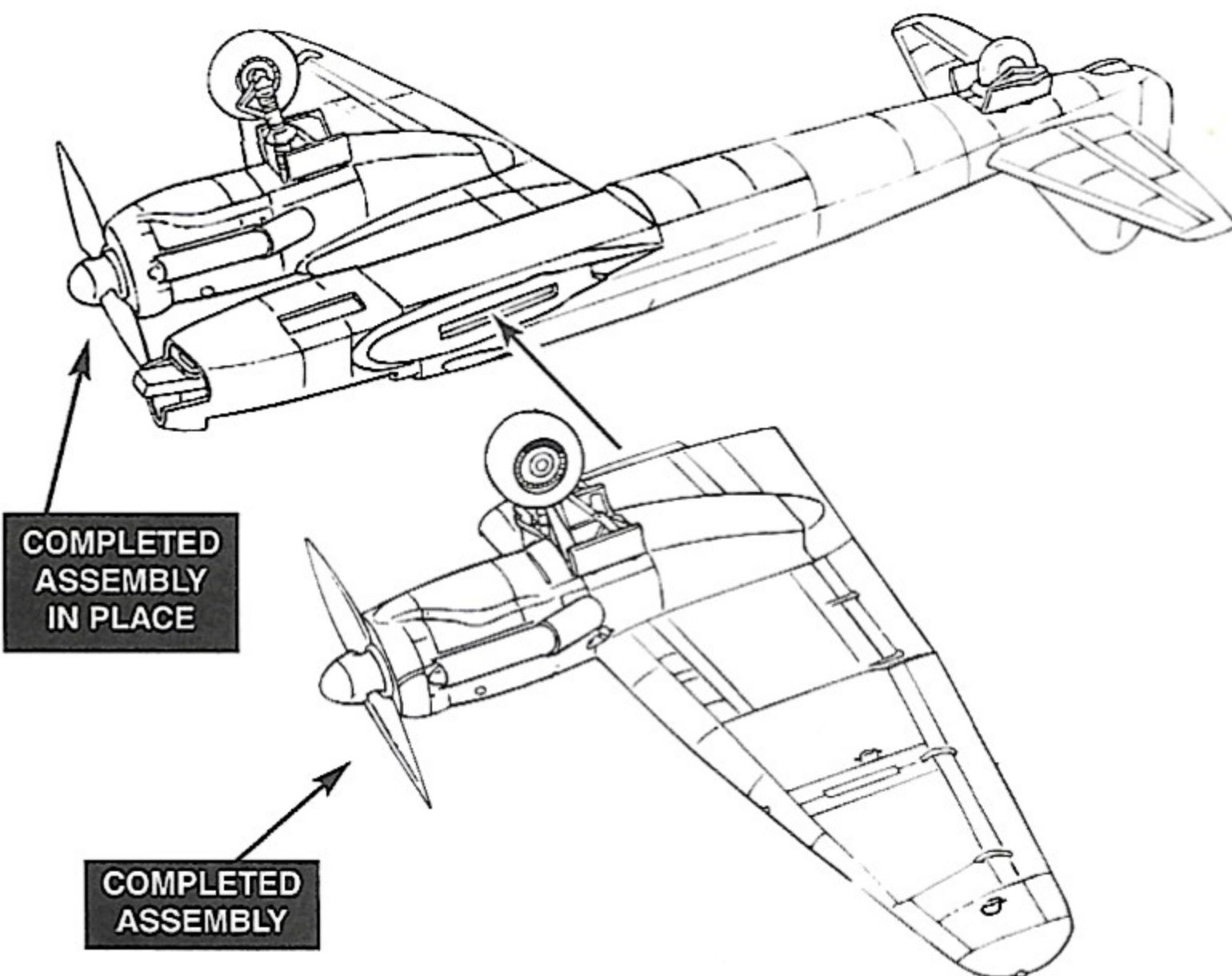
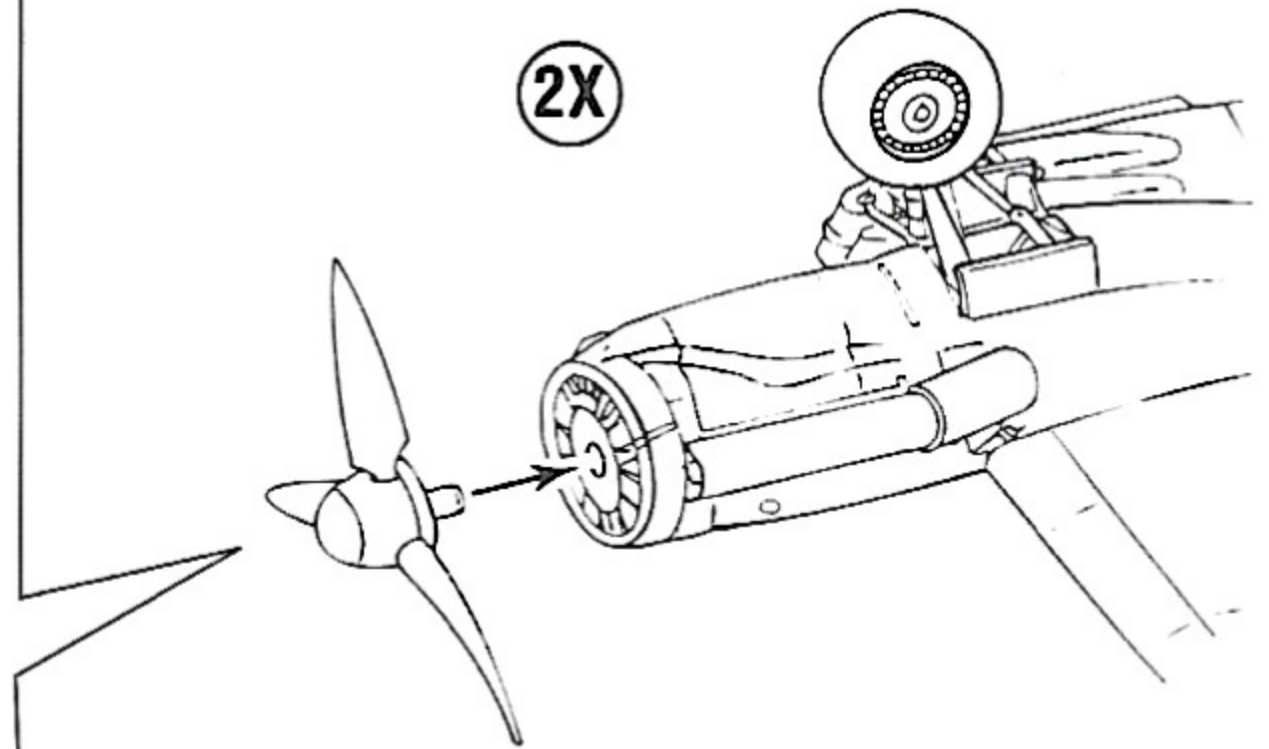
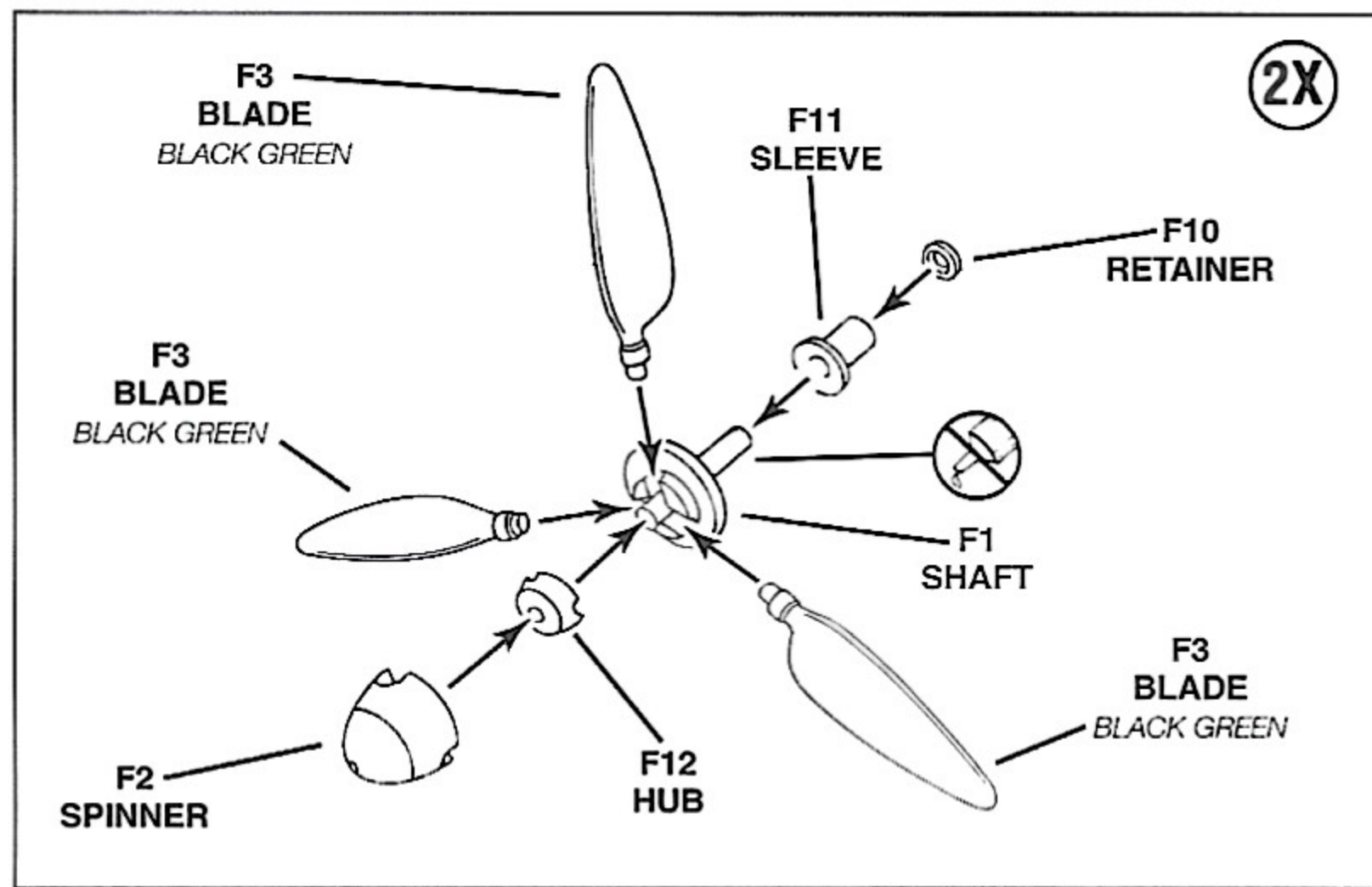

A

Q6 GONDOLA LEFT SIDE

Q5 GONDOLA LEFT SIDE

PAINTING NOTE: PAINT THE COMPLETED GONDOLA ASSEMBLY THE SAME COLOR AS THE UNDERSIDE OF THE FUSELAGE WHILE LEAVING THE WINDOW AREAS CLEAR

B

Q11 GONDOLA FRONT

I4 WINDOW CLEAR

C

M8 MG FF 20MM CANNONS GUNMETAL

E

A36 MG 15 7.92MM MACHINE GUN GUNMETAL

I2 REAR CANOPY CLEAR

I3 GUN MOUNT CLEAR

Z5 AMMUNITION BELT STEEL

A35 AMMO CHUTE GRAY

PAINTING NOTE: PAINT THE FRAMEWORK ON ALL CLEAR PARTS THE SAME COLOR AS THE SURROUNDING FUSELAGE

D

COMPLETED ASSEMBLY

A3 LOWER FUSELAGE CENTER SECTION

M9 FuBI 2 ANTENNA

PAINTING NOTE: STEP D IS THE BEST TIME TO PAINT THE CAMOUFLAGE SCHEME ON YOUR MODEL. FIRST CHECK THE ENTIRE MODEL FOR SEAMS OR CRACKS WHERE PARTS WERE JOINED TOGETHER. FILL ANY YOU FIND WITH MODELING PUTTY, THEN SAND IT SMOOTH ONCE THE PUTTY HAS HARDENED. SELECT ONE OF THE SCHEMES FOUND ON THE LAST SIX PAGES OF THIS INSTRUCTION BOOKLET AND APPLY IT CAREFULLY TO YOUR MODEL. LET THE MODEL DRY BEFORE YOU CONTINUE FURTHER

F

P3 ANTENNA MAST CLEAR

I1 FRONT CANOPY CLEAR

P2 REAR COCKPIT GLAZING

NOSE ASSEMBLY

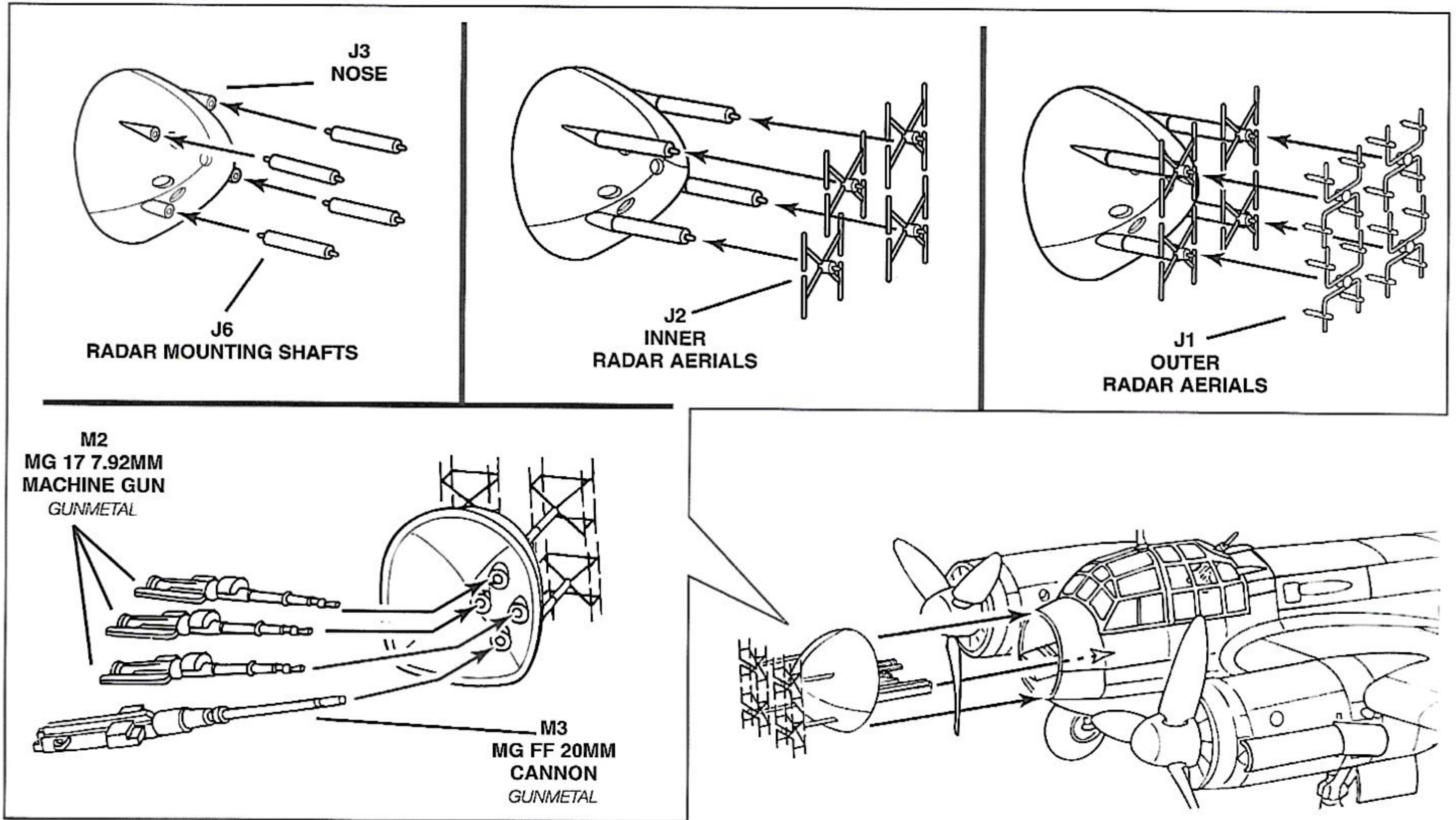

FINAL ASSEMBLY

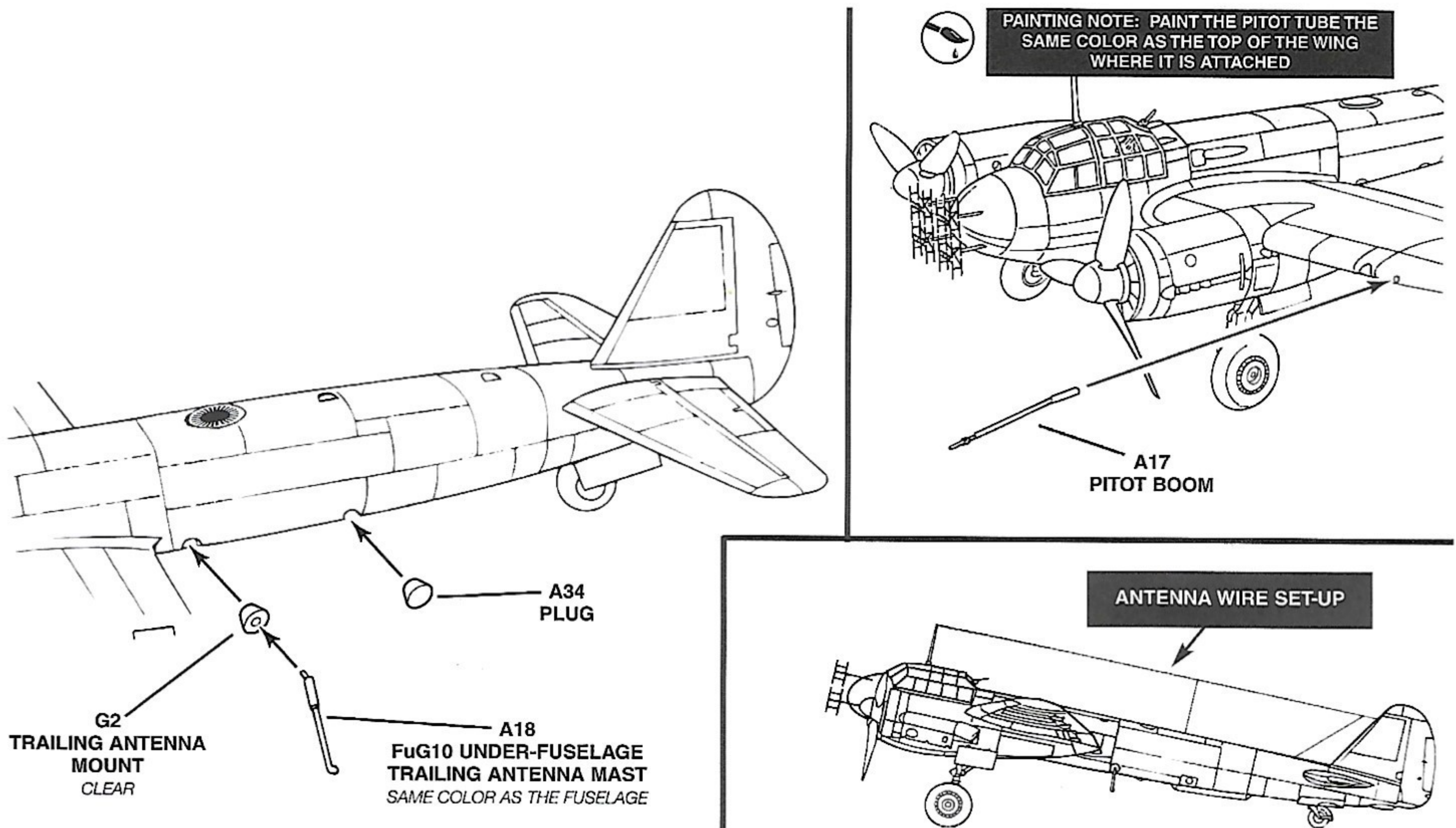



JUNKERS JU 88 C-6, 4./NJG2, 1942, HOLLAND, PILOT: HPTM. HELMUT LENT

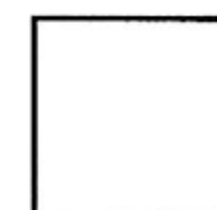
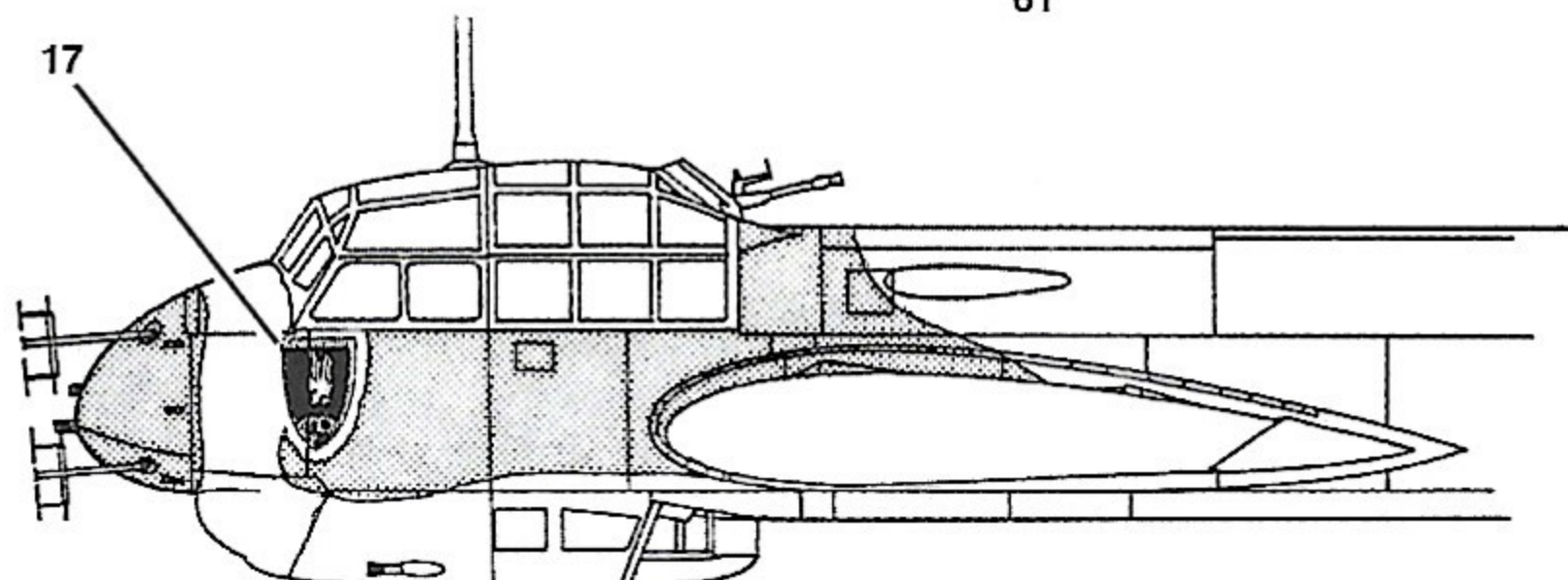
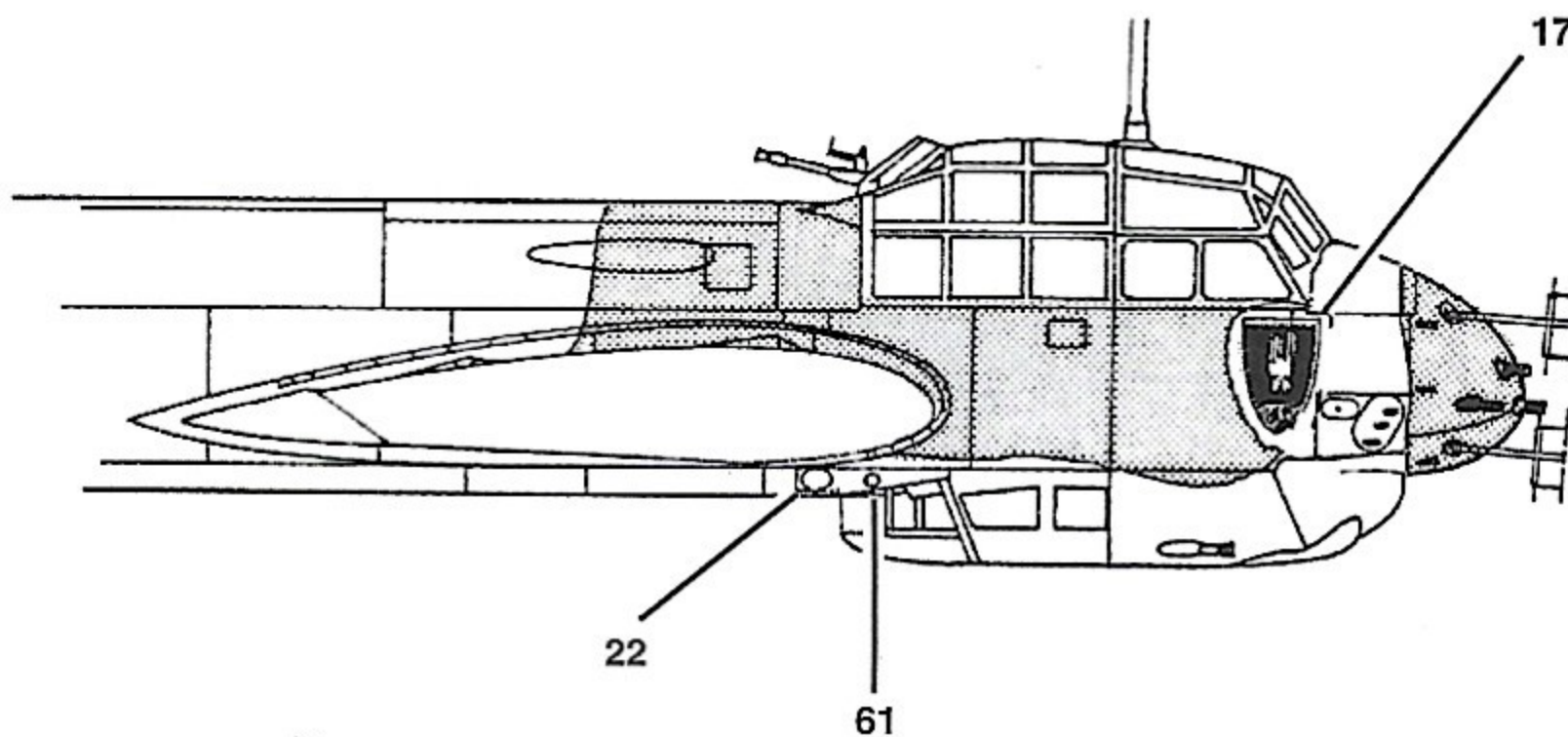
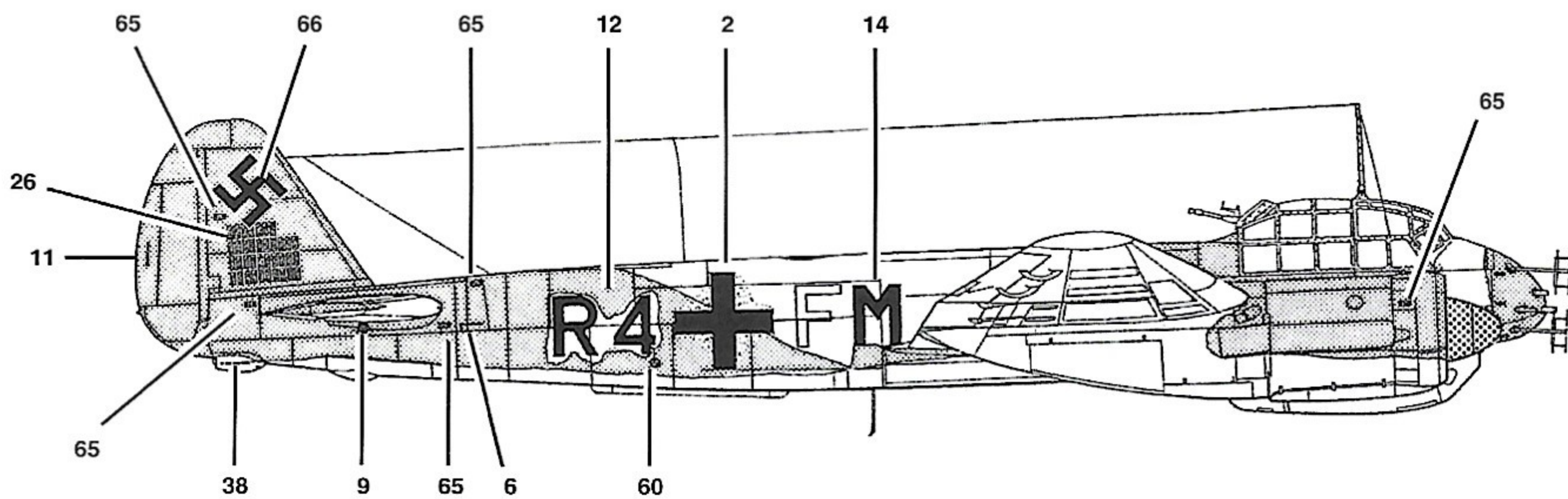
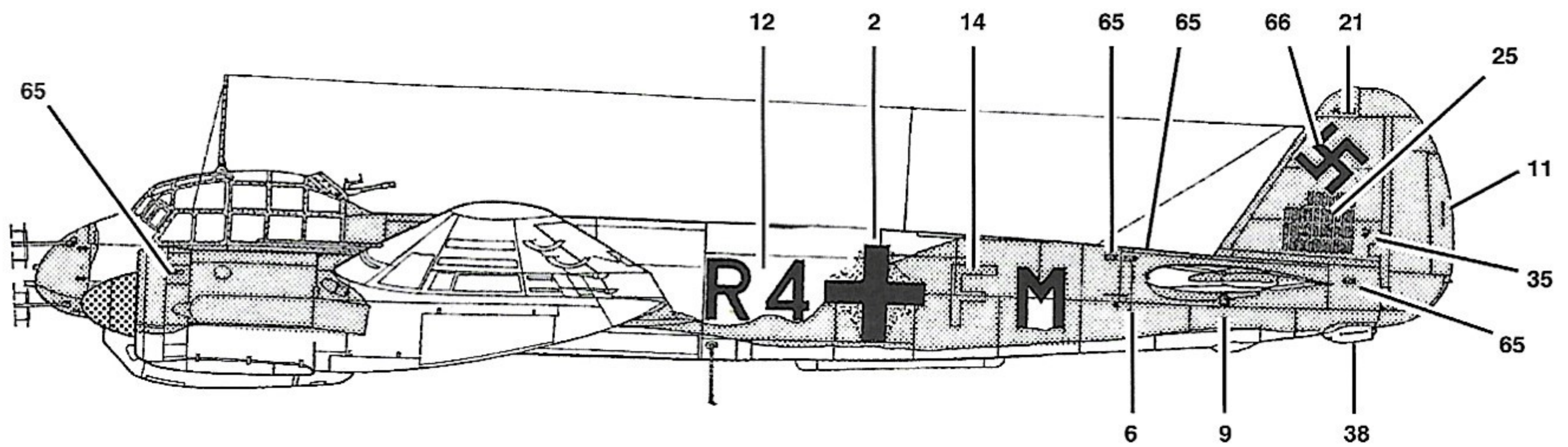

GRAY
RLM 02



DARK GRAY
RLM 74

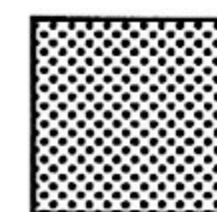

BLACK GREEN
RLM 70



**JUNKERS JU 88 C-6, 4./NJG2, 1942, HOLLAND, PILOT: HPTM. HELMUT LENT
TOP VIEW**

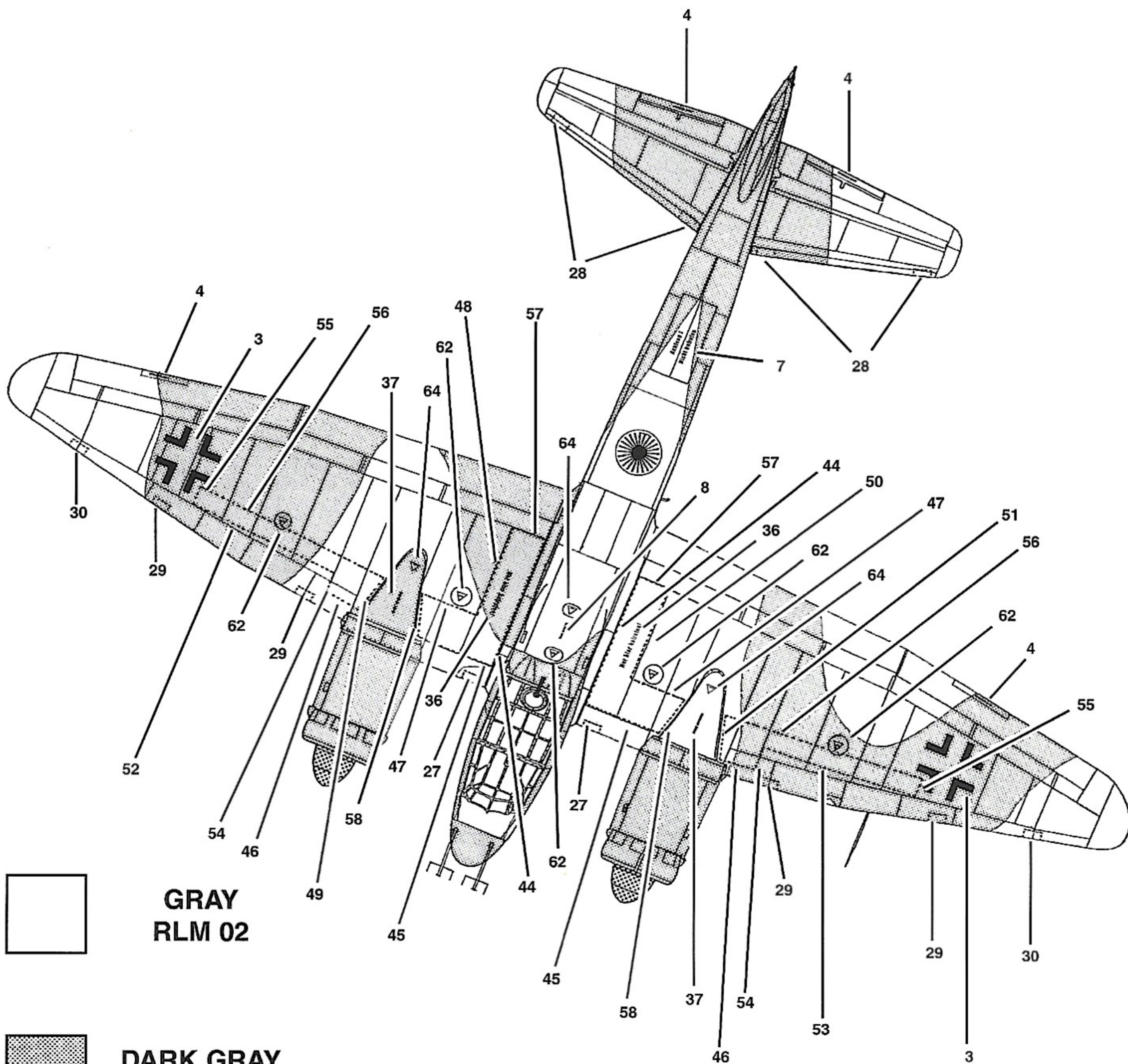

**GRAY
RLM 02**

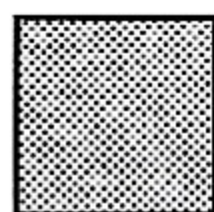

**DARK GRAY
RLM 74**

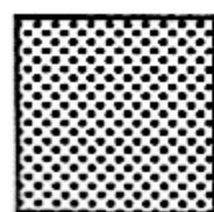

**BLACK GREEN
RLM 70**

NOTE: STENCIL DECAL PATTERN 44 THRU 58 WHICH IS SHOWN ON HPTM. HELMUT LENT'S JU 88 C-6 NIGHT FIGHTER IS ALSO APPLIED TO THE CATANIA SICILY VERSION BUT OMITTED FOR CLARITY



JUNKERS JU 88 C-6, 4./NJG2, 1942, HOLLAND, PILOT: HPTM. HELMUT LENT
BOTTOM VIEW

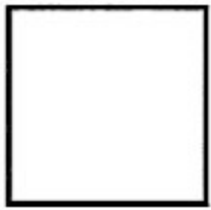

GRAY
RLM 02

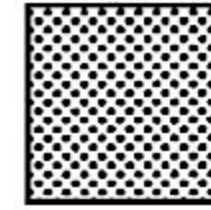

BLACK GREEN
RLM 70

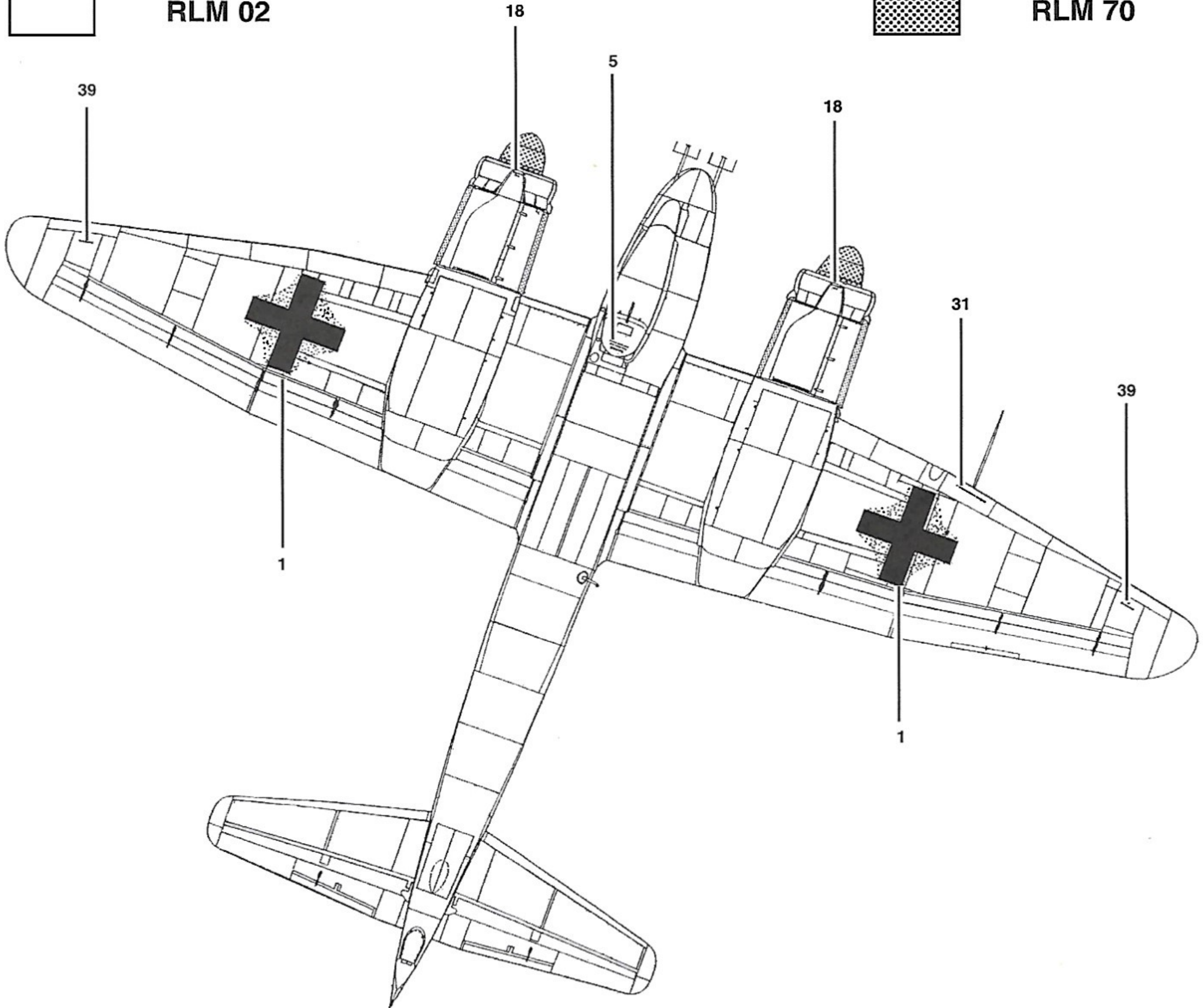



JUNKERS JU 88 C-6, 2./NJG2, JANUARY 1942, CATANIA, SICILY

PAINTING TIP

*

THE AREAS MARKED WITH THE ASTERIX HAVE A CAMOUFLAGE PATTERN OF WAVY STRIPES SAND (RLM 79) OVER DARK GREEN (RLM 71) BASE

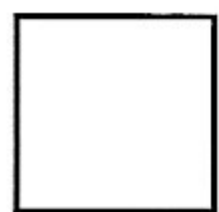
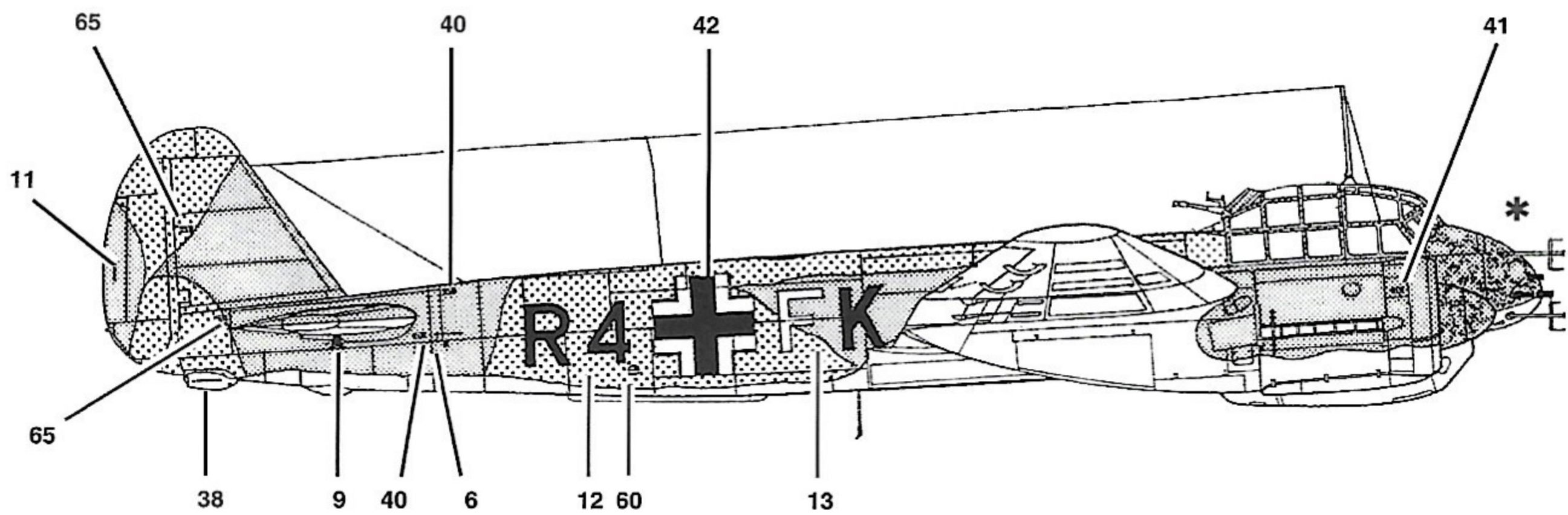
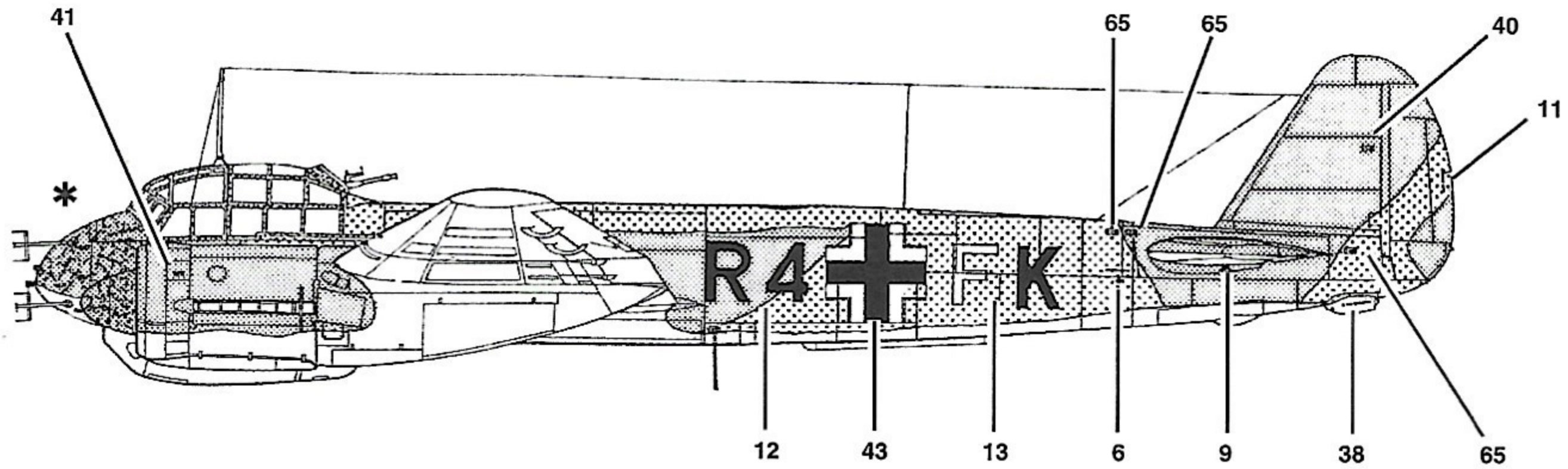

GRAY
RLM 76

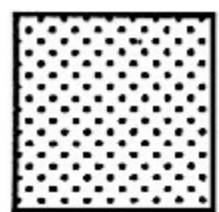

SAND
RLM 79

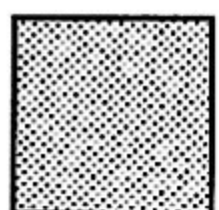

DARK GREEN
RLM 71

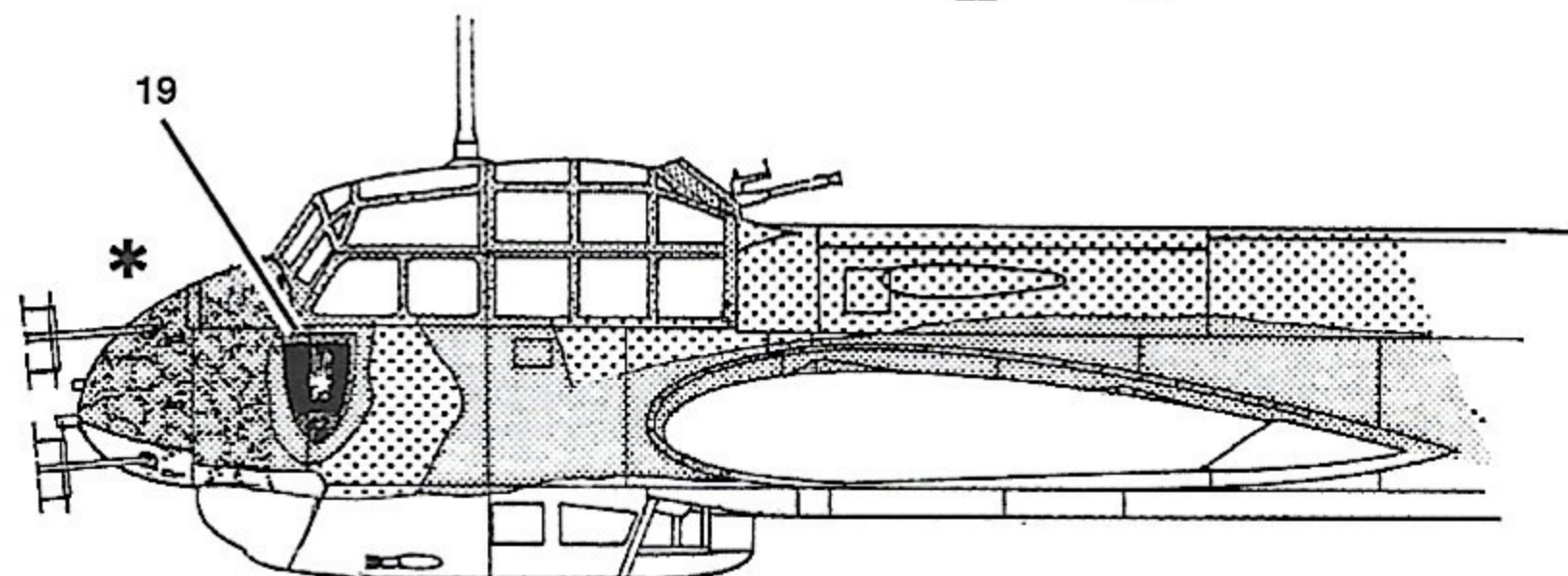
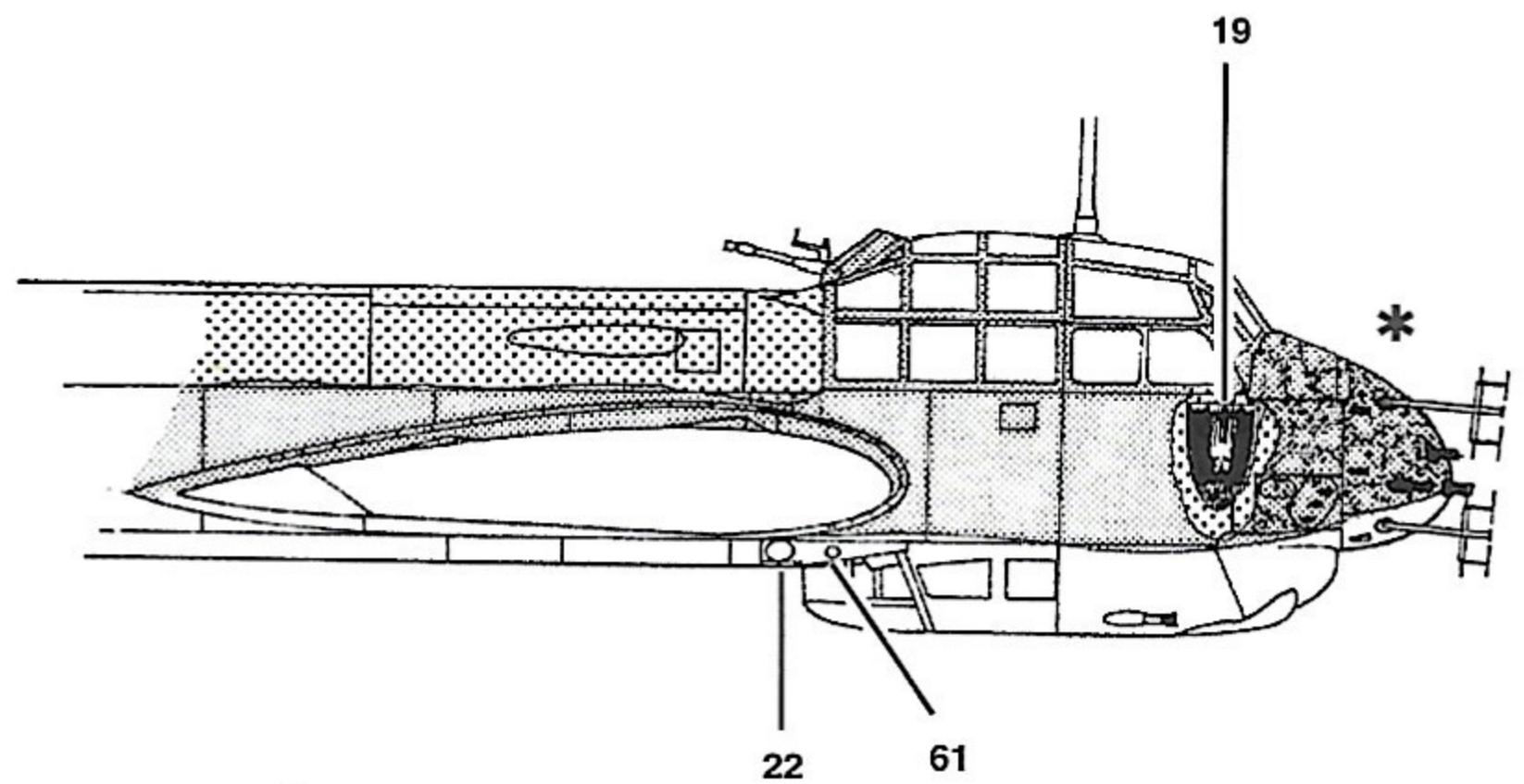



JUNKERS JU 88 C-6, 2./NJG2, JANUARY 1942, CATANIA, SICILY TOP VIEW

PAINTING TIP

*

THE AREAS MARKED WITH THE ASTERIX HAVE A CAMOUFLAGE PATTERN OF WAVY STRIPES SAND (RLM 79) OVER DARK GREEN (RLM 71) BASE

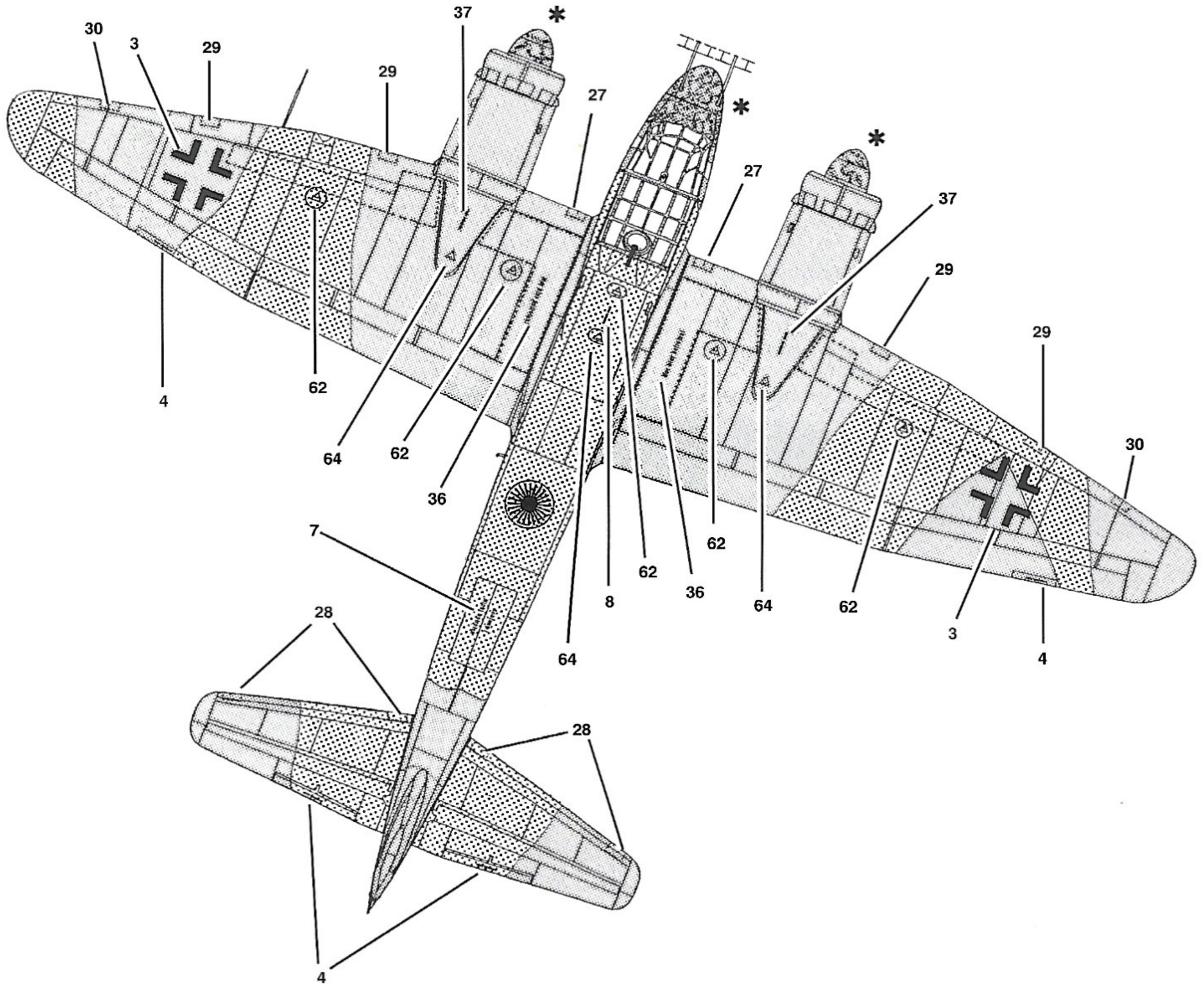

NOTE: STENCIL DECAL PATTERN 44 THRU 58, WHICH IS SHOWN ON HPTM. HELMUT LENT'S JU 88 C-6 NIGHT FIGHTER IS ALSO APPLIED TO THE CATANIA SICILY VERSION BUT OMITTED FOR CLARITY

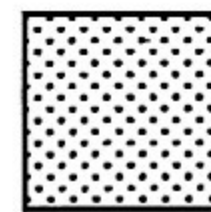

**SAND
RLM 79**

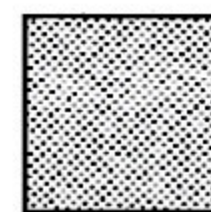

**DARK GREEN
RLM 71**



JUNKERS JU 88 C-6, 2./NJG2, JANUARY 1942, CATANIA, SICILY BOTTOM VIEW

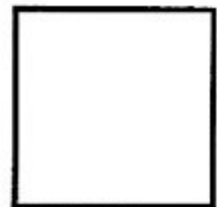

**GRAY
RLM 76**

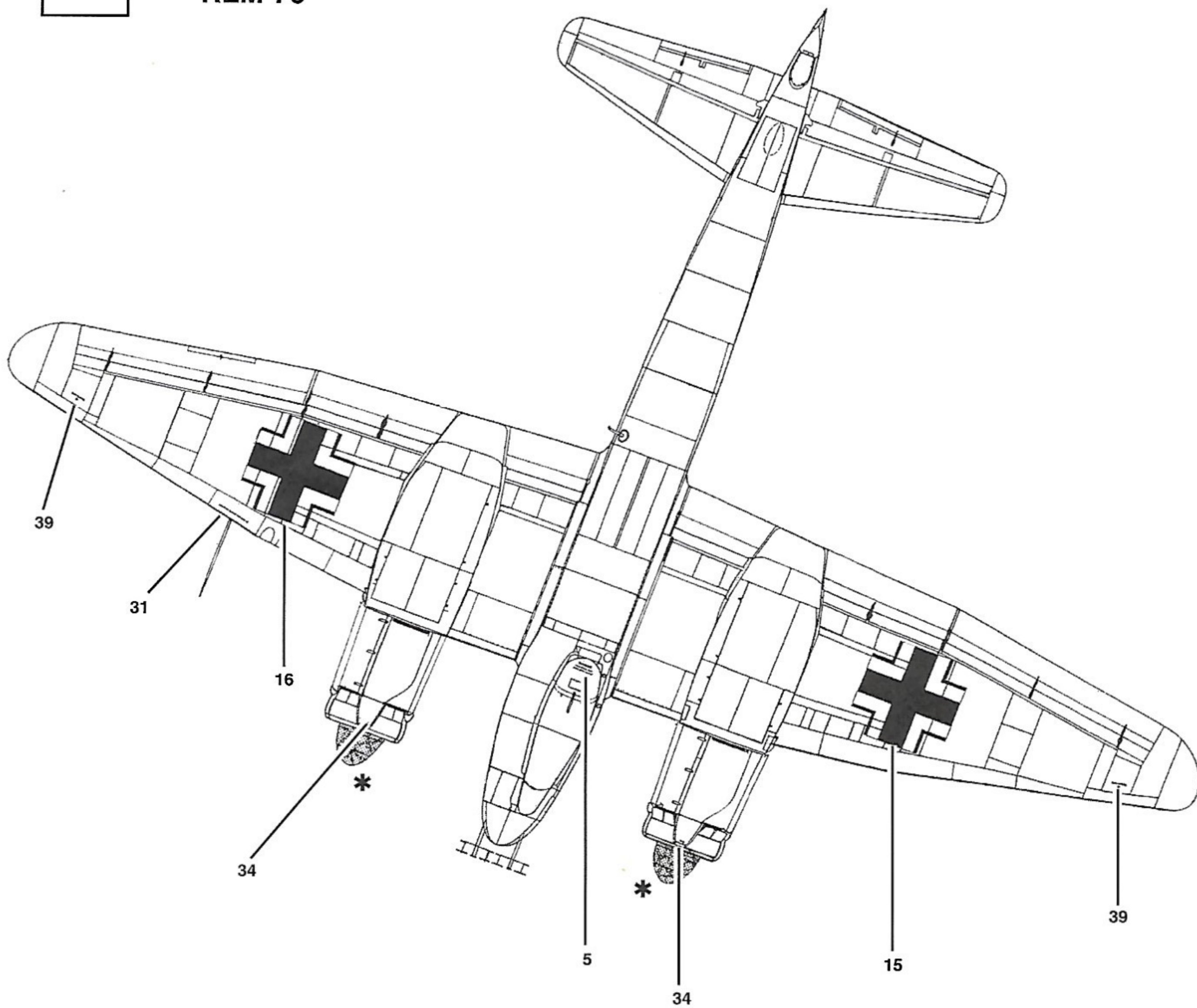

PAINTING TIP

*

THE AREAS MARKED WITH THE ASTERIX HAVE A CAMOUFLAGE PATTERN OF WAVY STRIPES SAND (RLM 79) OVER DARK GREEN (RLM 71) BASE