

Revell**BRISTOL BEAUFIGHTER Mk IC**

KIT 4660

1/32 SCALE

1/32 ECHELLE

ESCALA 1/32

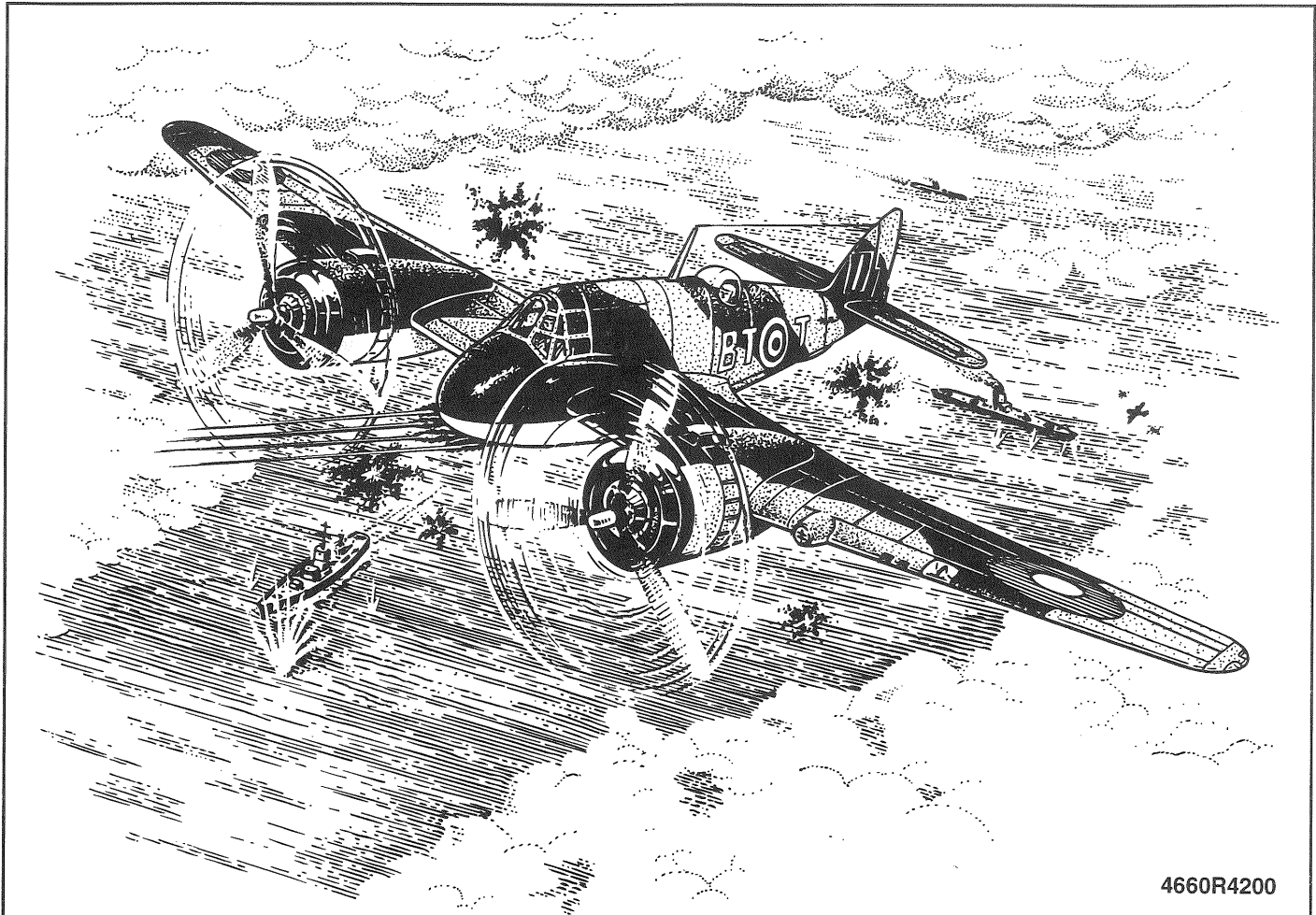

4660R4200

The Luftwaffe had switched to nocturnal sorties during the "Night Blitz" in autumn of 1940, and British cities suffered devastating bombing raids. The Royal Air Force lacked adequate aircraft, equipment, and tactics to counter the threat. The solitary encouraging part of picture was the the Bristol Beaufighter. This durable, long range heavy fighter was developed quickly, because it was constructed 75% off of an existing Bristol Beaufort bomber airframe. The Beaufighter entered service in September 1940, and during the winter their numbers increased rapidly, with airborne radar retrofitted to most of the early Mk I aircraft that had been delivered without it. In November 1940, Squadron 604 pilot John Cunningham and his observer, Sergeant J. Phillipson, shot down a JU 88A1 during a raid on Birmingham. It had been the first Beaufighter kill, and began a powerful and determined defense that would drive the Luftwaffe from English skies.

The Beaufighter Mk IC was a potent aircraft, powered by twin Bristol Hercules sleeve-valve engines developing 1460 horsepower each at 6250 ft. Two massive propellers drove the plane to a maximum speed of 321 mph at 15,800 ft. Four fixed 20mm Hispano cannons mounted in the belly and six fixed .303 Browning machine guns, four on the right, and two on the left, mounted in the wings, provided a knockout punch. The pilot's seat was at the center of all this action, behind a non-distorting bullet-proof windscreen in the nose. His observer sat behind him on a swivel seat, under a transparent dome. From there, he would navigate, operate the radio and radar, plus reload the ammo drums. Both pilot and observer had their own belly-mounted escape hatch.

Almost all of the first batches of Beaufighters were night fighters. As the war expanded on every front, these planes served in coastal strike and ground attack roles as well. Several hundred formed the backbone of the Allied long range heavy fighter force in both Italy and in the Middle East. Your Revell kit depicts a Beaufighter Mk IC of the RAF Coastal Command, which served in the Mediterranean theater during 1942.

REVELL-MONOGRAM INC. MORTON GROVE, IL. COPYRIGHT© 1994. ALL RIGHTS RESERVED. MADE IN U.S.A.

If you have any problems building this model, call our modeling tips hotline at: **(800) 833-3570**

READ THIS FIRST

- Study the assembly drawings.
- Each plastic part is identified by a number.
- Scrape plating from areas to be cemented
- Check the fit of each piece before cementing in place.
- Do not use too much cement to join parts.
- Use only cement for polystyrene plastic.
- Model may be painted to match photos on box.
- Scrape paint from areas to be cemented.
- For better paint and decal adhesion, wash the plastic parts in a mild detergent solution. Rinse and let air dry.

LEA ESTO ANTES DE EMPEZER

- Estudie los dibujos de ensamblaje.
- Cada pieza de plástico se identifica por un número.
- Verifique que cada pieza encaje bien antes de posición.
- No use demasiado pegamento para unir las piezas.
- Use únicamente pegamento para plástico de poliestireno.
- El modelo puede pintarse de acuerdo con las fotografías de la caja.
- Permita que se seque la pintura completamente antes de tocar las piezas.
- Raspe la pintura de las superficies que serán pegadas.
- Para una mejor fijación de la pintura y de las calcomanías lávese las piezas plásticas en una solución de detergente suave. Enjuaguense y dejense secar al aire.

LISEZ CE QUI SUIT AVANT DE COMMENCER LE MONTAGE

- Etudier les schémas d'assemblage.
- Chaque pièce plastique porte un numéro d'identification.
- Contrôler que chaque pièce soit bien cinfirmé avant de la coller a sa place.
- N'utilisez pas trop de colle pour réunir les pièces.
- Utilisez uniquement une colle spéciale pour polystyrene.
- Le modèle peut être peint conformément aux photos sur la boîte.
- Laissez sécher la peinture complètement avant de manipuler les pièces.
- Grattez la peinture sur les surfaces devant être collées. Pour assurer la meilleure adhésion possible de la peinture et des décalomnies, lavez les pièces de plastique avec une légère solution savonneuse. Rincez et laissez sécher à l'air.



DECAL (DIP IN WATER)
DECALCOMANIE (APLONGERDANS L'EAU)
DECALCOMANIA (MOJE CON AGUA)



ALTERNATIVE ASSEMBLY
ENSEMBLE ALTERNATIVO
ENSEMBLAGE ALTERNATIVE



REPEAT SEVERAL TIMES
A REPETER PLUSIEURS FOIS
REPITA VARIAS VECES



DO NOT CEMENT
NE PAS COLLER
NO USE PEGAMENTO



OPTIONAL PARTS
PIECES EN OPTION
PIEZAS OPCIONALES

FLAT BLACK	NOIR TERNE	NEGRO APAGADO
RED	ROUGE	ROJO
YELLOW	JAUNE	AMARILLO
ARMOR SAND	BRUN	MARRON
RADOME TAN	BRUN CLAIR	CANELA
CREAM	COULEUR DE LAPEAU	COLOR DE LAPIEL
OLIVE DRAB	VERT OLIVE	ACEITUNADO
BLUE	BLEU	AZUL
GRAY	GRIS	GRIS
DARK GRAY	GRIS FONCE	GRIS OSCURO
STEEL	METALLIC	METALICO
SILVER	ARGENT	PLATA
COPPER	CUIVRE	COBRIZO

A COMPLETE GUIDE FOR PAINTING THIS AIRCRAFT APPEARS AT THE END OF THIS INSTRUCTION BOOKLET

Revell, Model Kits has put forth every effort to create and manufacture the finest model kit available. If a part may be missing, please write to:

REVELL, MODEL KITS
Consumer Service Department
301 North Third Avenue
Des Plaines, Illinois 60016

Be sure to include the kit number, part number, description, and your return address.

1 ENGINE ASSEMBLY

STEP

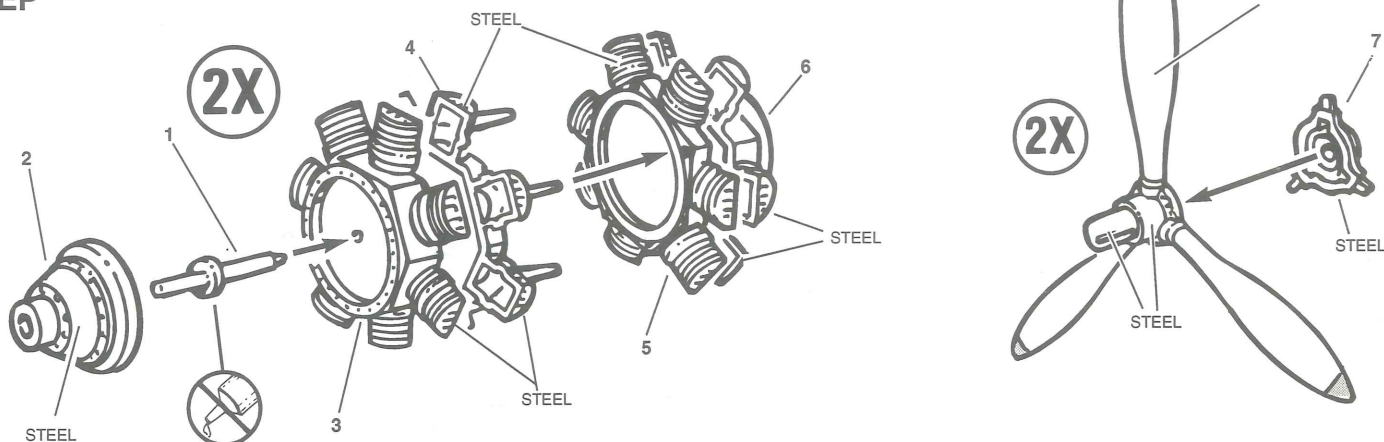

2 COCKPIT ASSEMBLY

STEP

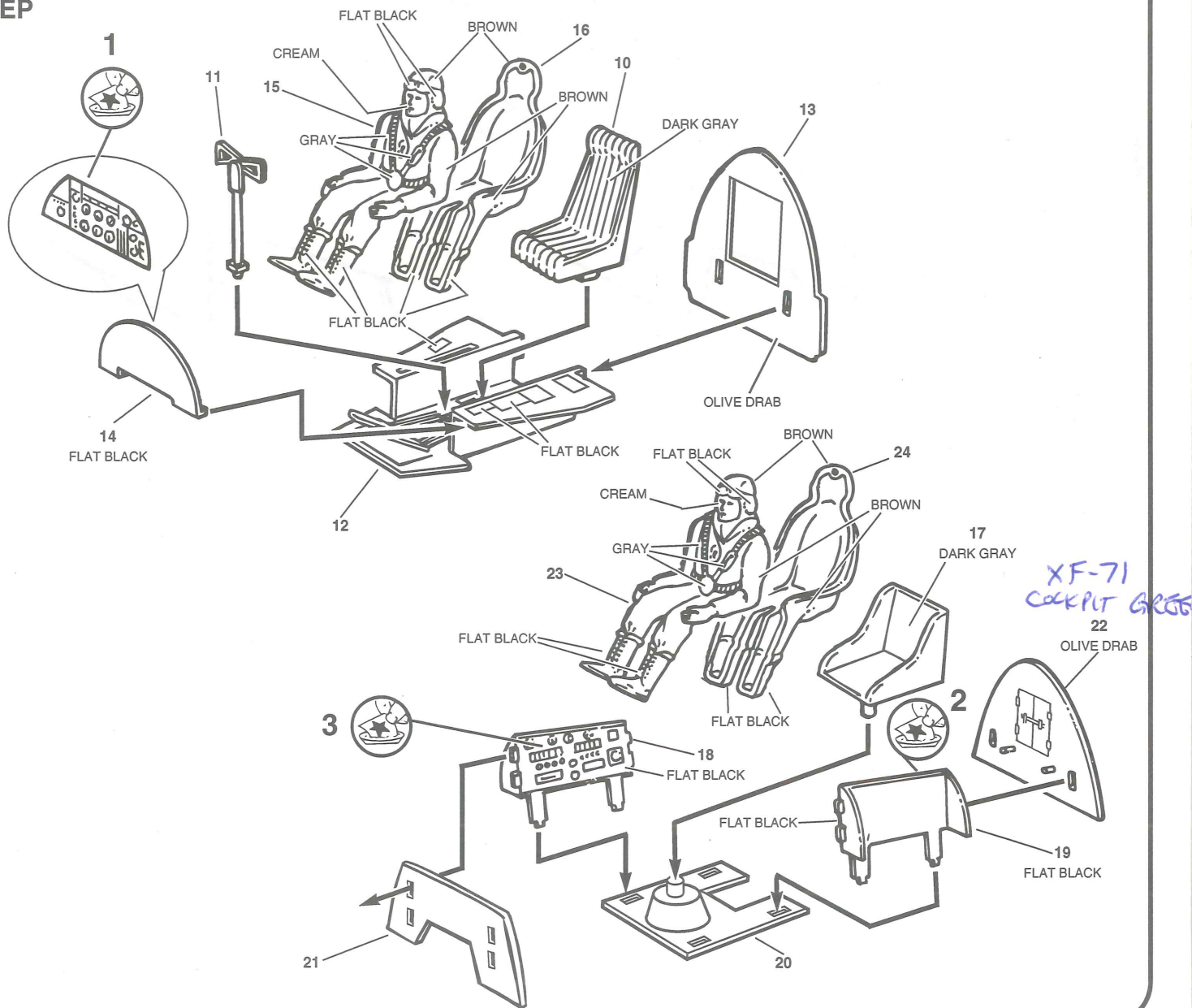

3

STEP

FUSELAGE ASSEMBLY

COMPLETED
COCKPIT
ASSEMBLIES

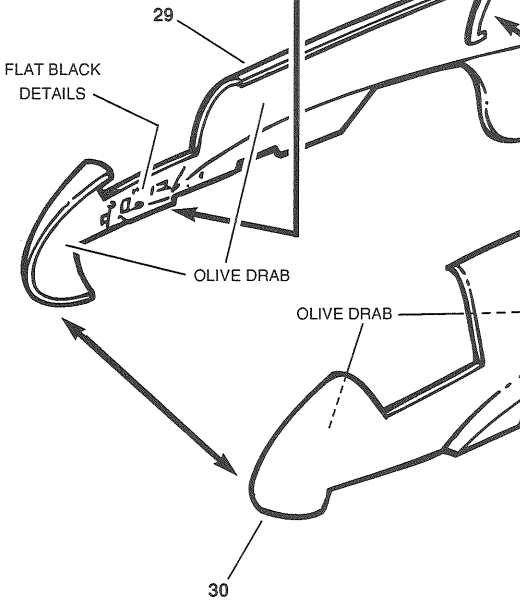
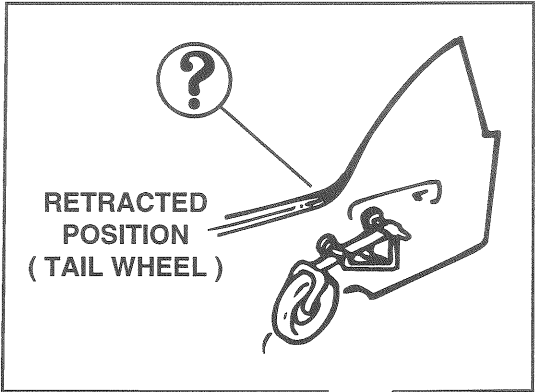

COMPLETED
ASSEMBLY

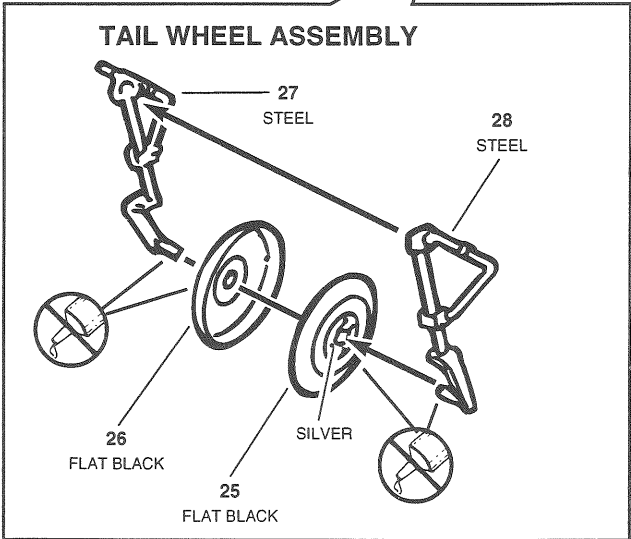

4 STEP

AIRFRAME ASSEMBLY

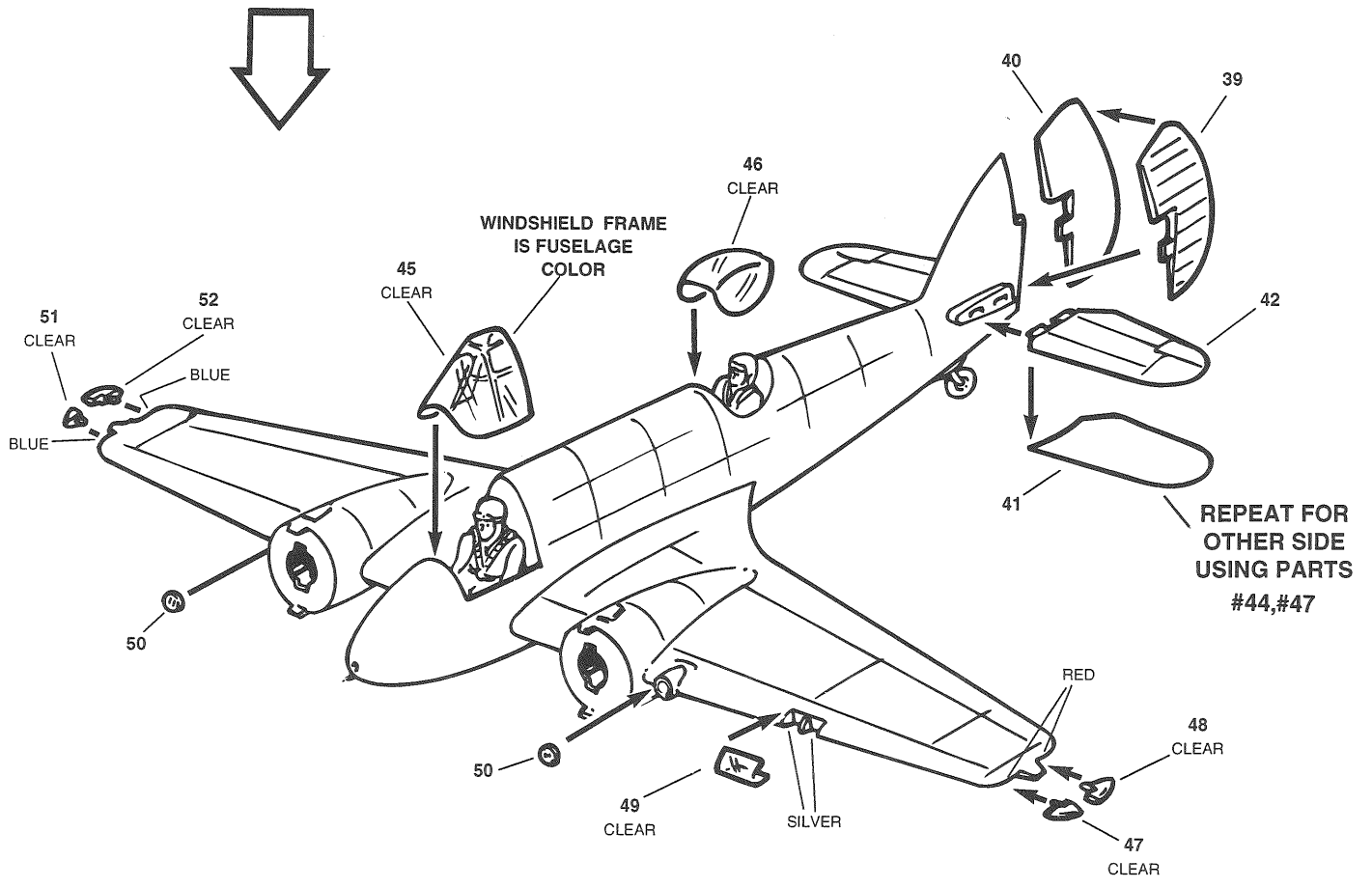
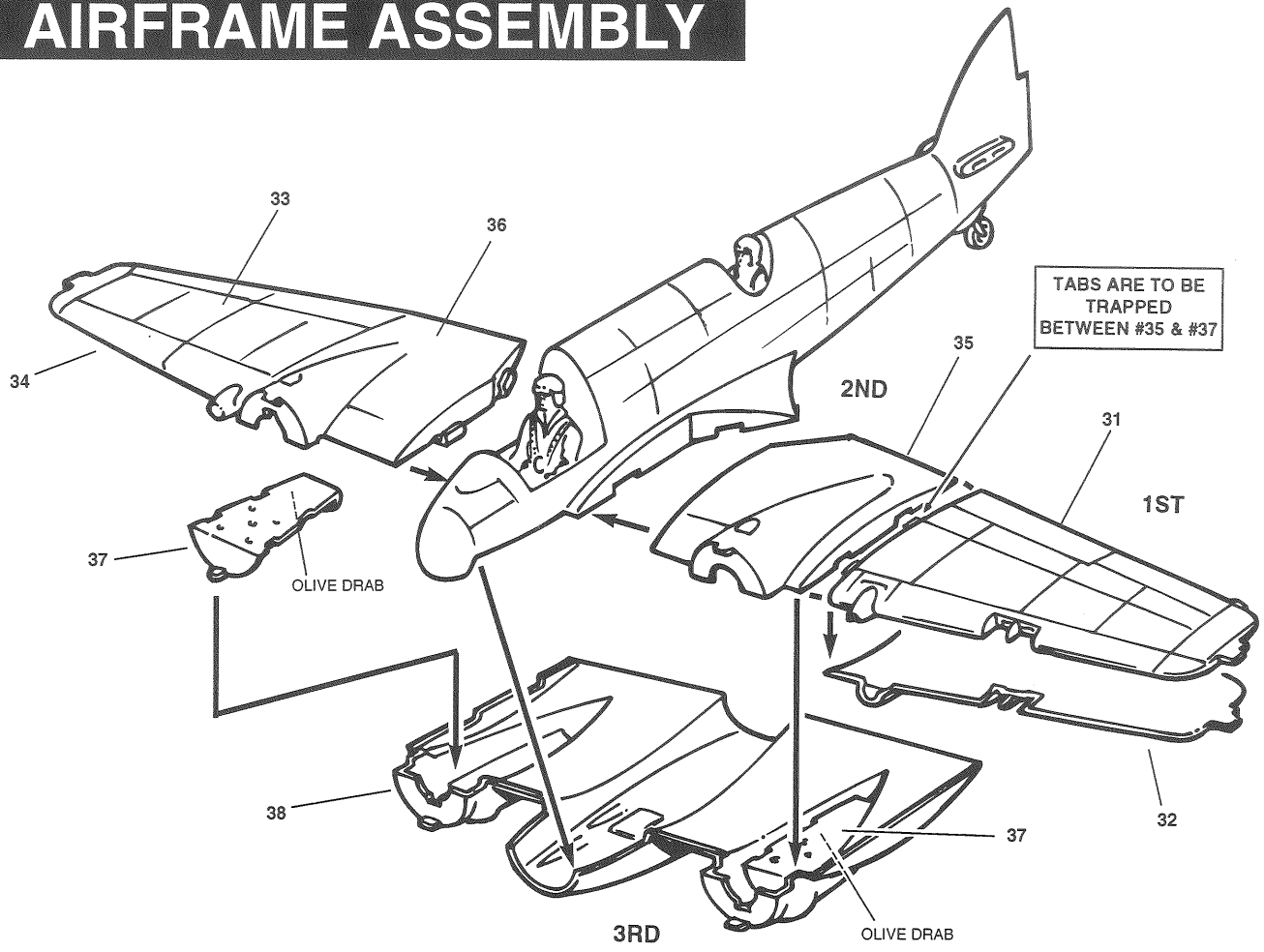



APPLY DECALS

BRISTOL BEAUFIGHTER MK IC FLOWEN BY No.252 SQUADRON
RAF COASTAL COMMAND, EDCU EGYPT, 1942.

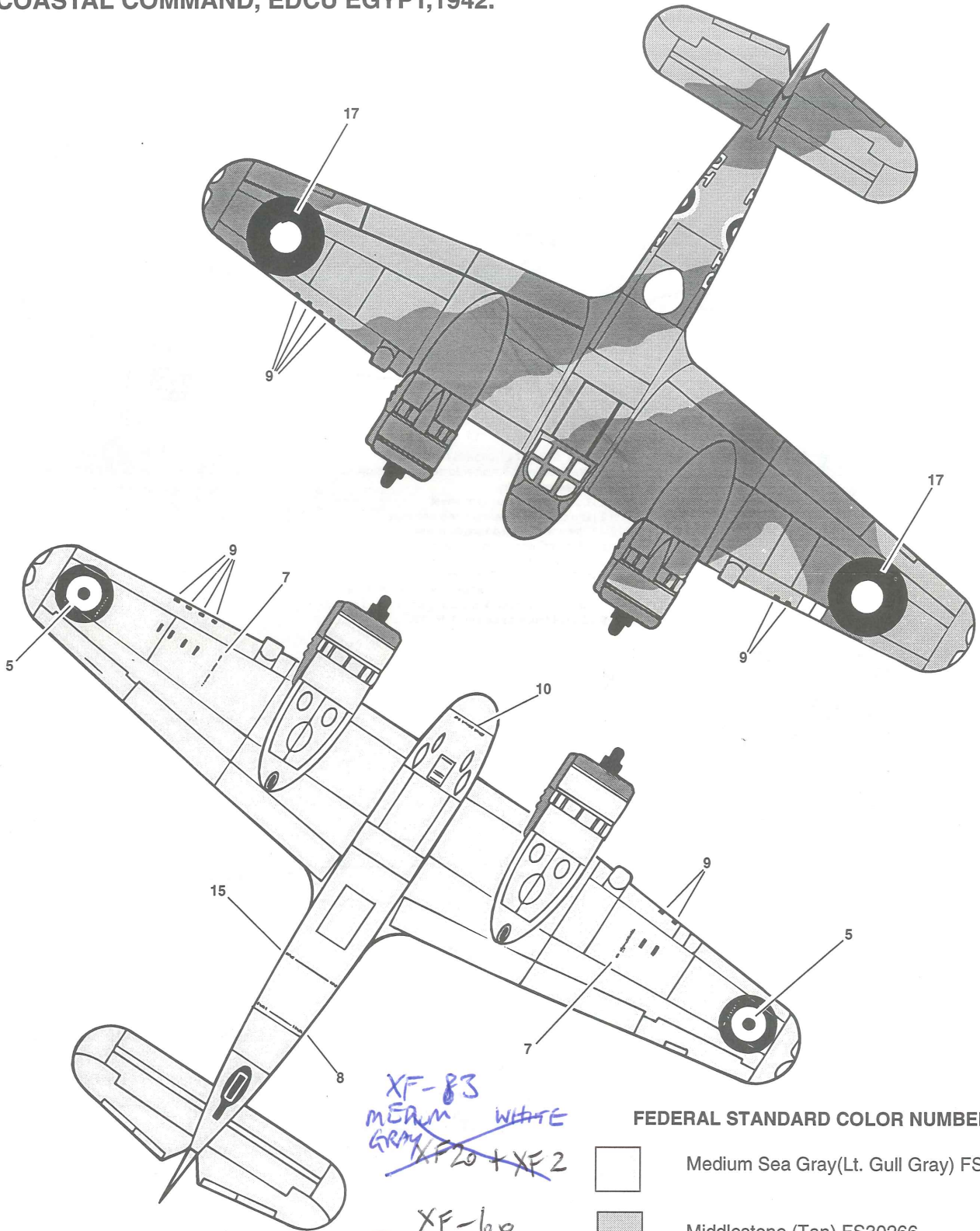



MAYBE
XF-78 DECK TAN ?

XF-83
MEDIUM WHITE
GRAY
~~XF-20 + XF-2~~

XF-60
DARK YELLOW
XF-52
FLAT EARTH

FEDERAL STANDARD COLOR NUMBERS

-  Medium Sea Gray(Lt. Gull Gray) FS 36440
-  Middlestone (Tan) FS30266
-  Dark Earth FS 30118



APPLY DECALS

BRISTOL BEAUFIGHTER MK IC FLOWEN BY No.252 SQUADRON
RAF COASTAL COMMAND, EDCU EGYPT, 1942.

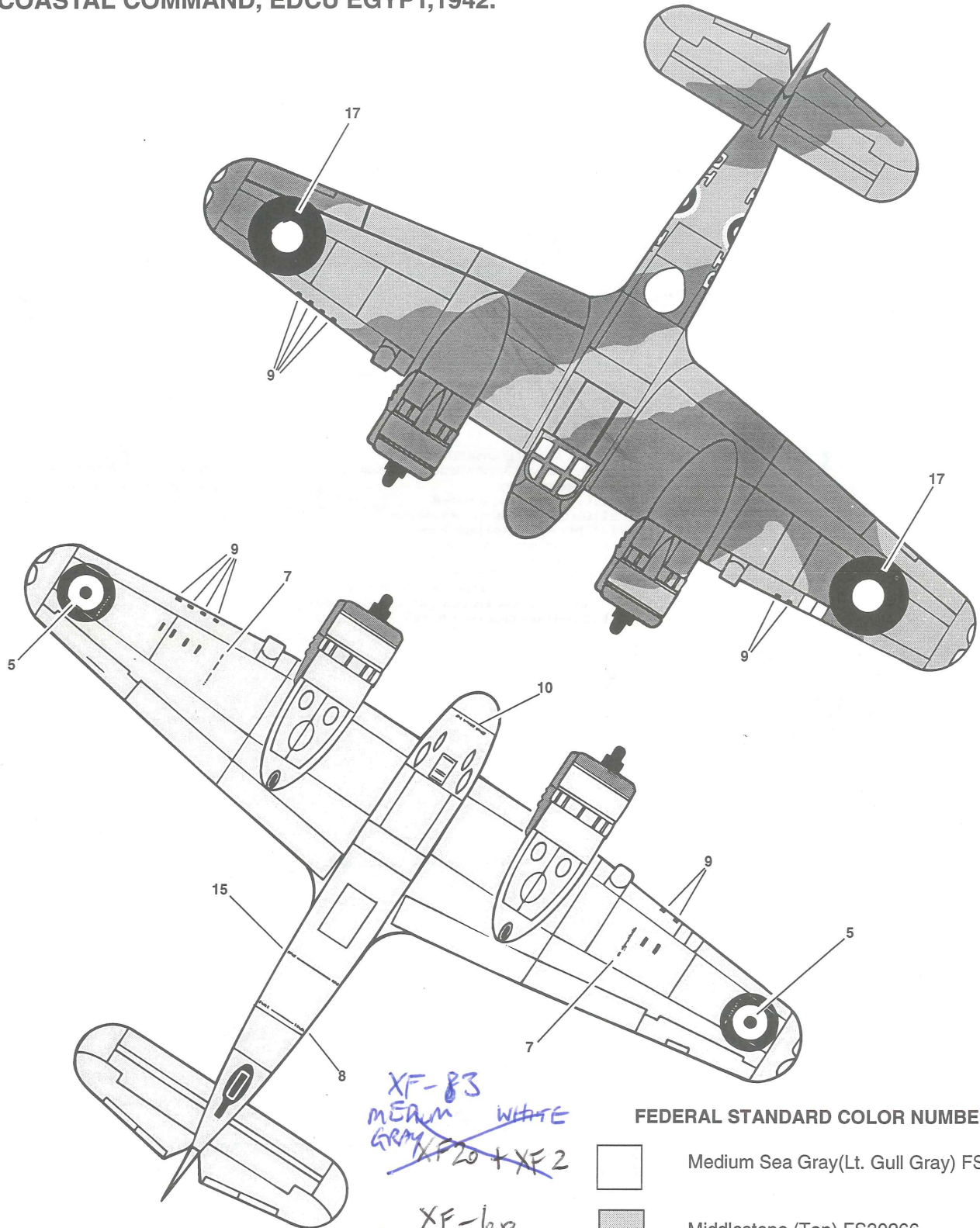

MAYBE
XF-78 DECK TAN ?

XF-83
MEDIUM GRAY
~~XF20 + XF2~~
WHITE

XF-60
DARK YELLOW
XF-52
FLAT EARTH

FEDERAL STANDARD COLOR NUMBERS

-  Medium Sea Gray(Lt. Gull Gray) FS 36440
-  Middlestone (Tan) FS30266
-  Dark Earth FS 30118



APPLY DECALS

**BRISTOL BEAUFIGHTER MK IC FLOWN BY No.252 SQUADRON
RAF COASTAL COMMAND, EDCU EGYPT,1942.**

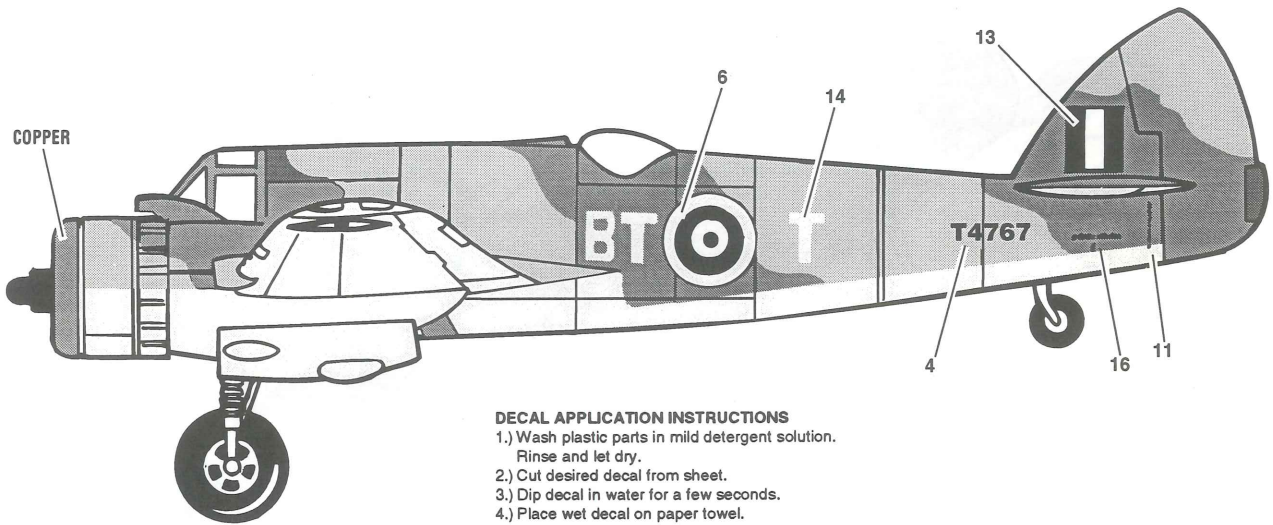

DECAL APPLICATION INSTRUCTIONS

- 1.) Wash plastic parts in mild detergent solution. Rinse and let dry.
- 2.) Cut desired decal from sheet.
- 3.) Dip decal in water for a few seconds.
- 4.) Place wet decal on paper towel.
- 5.) Wait until decal is movable on paper backing.
- 6.) Place decal in position on model, face up and slide backing away.
- 7.) Press out air bubbles with a soft damp cloth.
- 8.) Milkyness that may appear is for better decal adhesion and will dry clear. Wipe away any excess adhesive.
- 9.) Do not touch decal until fully dry.

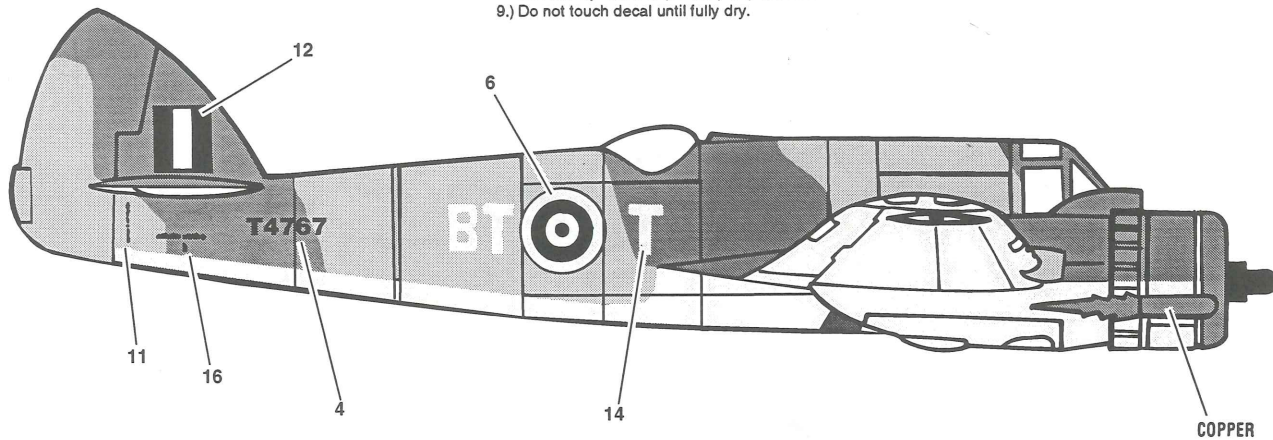

FEDERAL STANDARD COLOR NUMBERS

The box top can be used as a guide to paint your model, or you may wish to use the painting information on this page to achieve a more accurate finish. The listed numbers refer to color samples printed in GSA SPECIFICATIONS. This publication is available from:

**FEDERAL SUPPLY SERVICE BUREAU
GSA SPECIFICATIONS
470 East Lafant Plaza SW.
Suite 8100
Washington, D.C 20407**

Write to GSA for information regarding current price and availability.

FEDERAL STANDARD COLOR NUMBERS

*XF-83
MEDIUM
SEA GRAY*



Medium Sea Gray(Lt. Gull Gray) FS 36440

~~XF-20 + XF-2 MEDIUM GREY
FLAT WHITE~~

Middlestone (Tan) FS30266

~~XF-60 DARK YELLOW~~ XF 59

Dark Earth FS 30118

~~XF-52 FLAT EARTH~~

*DESERT
YELLOW
XF-78
DELT TAN*