

M115
8in
HOWITZER

M115 8吋榴彈砲

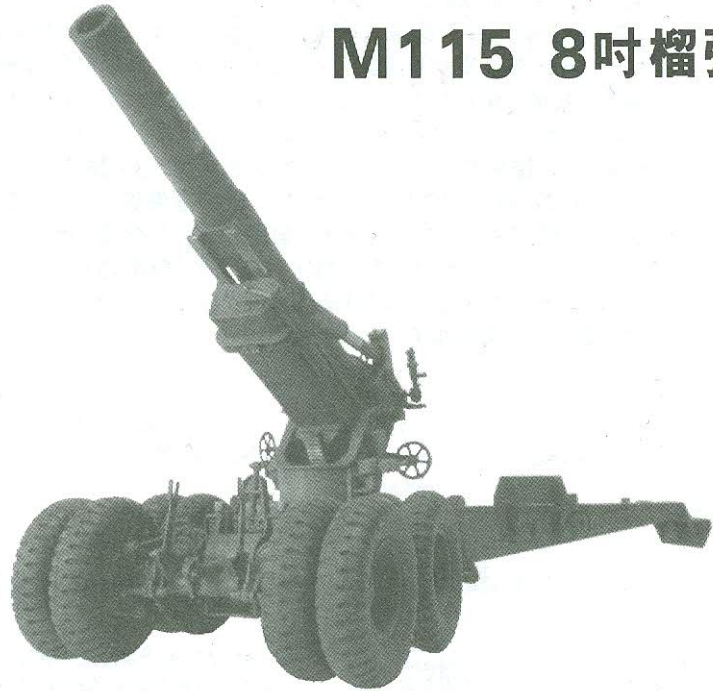

M-115 8inch Howitzer

In order to achieve firepower equivalent to a Division, the U.S.Army had been refining their M1918 155mm cannon's design since the 1920s, including using the same main frame for both the 155mm and 203mm cannons. Although fields testing of these cannons were outstanding the projects were terminated due to lack of funds.

It was until 1941 when the M-2 tube mounted on an M-1 main frame 203mm Howitzer was accepted by the U.S.Army into service, and was used mainly by the artillery divisions. Their main objectives were to destroy enemy's strongholds, transportation routes, bunkers and bridges. By 1945 a total of 1006 howitzers were produced.

Throughout WWII the M-2 203mm howitzers were outstanding in performance and were used in famous battles throughout the Italian Campaign as well as the Pacific War. After WWII, the U.S.Army reorganized their equipment structure and renamed the M-2 to M-115.

During the Korean War the M-115 was the biggest howitzer on the ground and later was even converted to carry the M-422 Nuclear warhead. In 1958 during the outbreak of the Chinese civil war, the U.S. Supplied M-115 and the M-55 Self-propelled guns again showed their might and inflicted heavy casualties, on the enemy.

M-115 Specifications:

Length:10.97m

Width:2.51m

Height:2.74m

Weight:28000lb

Muzzle Vel:1950 f/s

Range:18510 yd max

M-115 8吋榴彈砲

美國陸軍為達到師級砲兵的火力需求,自1920年代起針對國產的M1918,155mm加農砲進行改良計畫,為簡化後勤作業,此計畫中尚包含將155mm與203mm口徑火炮之砲架共通化,雖然這兩型原型火炮測試性能十分傑出,但計畫卻因缺乏經費而告中止,至1929年共用砲架開發成功,1941年以M-1砲架搭載M-2砲身的203mm榴彈砲獲美軍採用,此砲配屬於美軍之軍直屬砲兵部隊,主要用來摧毀敵軍堅強工事、交通線、砲壘與橋樑,至1945年止共生產1006門。

二次大戰期間M-2 203mm榴彈砲在突出部戰役之巴斯通解圍及義大利戰線,皆有傑出的表現,亦曾使用於太平洋戰線之琉球戰役,二次大戰結束後,美國陸軍對其裝備重新編號,M-2榴彈砲改定型號為M-115。

韓戰時M-115成為戰時最大口徑的地面火炮,並開發出供其使用之M-422核子彈頭。1958年於中國沿海地區國民黨與共產黨軍隊爆發衝突,美國緊急軍援M-115榴彈砲與M-55自走榴彈砲予金門島之國民黨守軍,因203mm砲之威力造成共軍重大傷亡,共方懷疑是核子彈頭造成,使得戰事得以和緩,兩岸對峙局勢延續至今。

M-115 性能諸元:

全長:10.97公尺

全寬:2.51公尺

全高:2.74公尺

總重:13.86公噸

砲口初速:594公尺/秒

射程:16.92公

M115 203mm榴弾砲

1920年代アメリカ陸軍は、師団レベルの支援火力向上の要求により、M1918 155mm砲の改良プログラムを立案しました。このプログラムは、運搬作業の効率化のため155mm砲と203mm砲の砲車を兼用することも含まれていました。2つの試製砲の性能は、ずば抜けていたにもかかわらず、開発プログラムは、予算削減のあおりを受け中止されました。

1929年以前に共用砲車の開発に成功していたアメリカ陸軍は、M2シャーシのついたM1砲車を使用した203mm野戦榴弾砲を配備しました。これらの榴弾砲は軍団直轄の砲兵隊に配備され、主に陣地、交通路、要塞、橋梁の破壊に使用、1945年までに1,006門が製造されました。

第二次大戦中M-2 203mm榴弾砲は、バルジの戦いやイタリア戦線、太平洋戦線の硫黄島などでめざましい活躍を見せました。第二次大戦後アメリカ陸軍は、M-2榴弾砲をM-115に改称しました。M-115は朝鮮戦争において、最大口径の榴弾砲として活躍しました。そのころM115用としてM422核弾頭も開発されました。1958年国民党軍と共産軍の戦いが勃発した際、アメリカ陸軍は、M-115榴弾砲とM-55自走砲を金門島地区に緊急展開しました。なぜならば大変強力な核弾頭により共産軍に大きな損害を与えることが可能だったからです。これにより交戦は回避され、台湾海峡をはさんだ対立は今日まで続いています。

データ M115

全長:10.97m
重量:13.86t

全幅:2.51m
砲口初速:594(m/s)

全高:2.74m
射程:16.92km

Illustration: 圖示説明



Agglutinate
用膠黏合



No Agglutinate
不用黏合



Make 2 Sets
二組製作



Cut Off
切除



Optional
選擇使用



Apply Decal
貼上貼紙



Be Careful
注意



Open Hole
鑽孔加工

Method For Applying Decals:

1. Clean Model Surface With Wet Cloth.
2. Cut Out Of Decal Sheet And Dip Them In Water For 15 Seconds.
3. Place it on proper position on model.
4. Slide off base paper leaving decals On Model With Wet Finger Tip.
5. Move Decals To Exact Position, Push Out Excess Water Under Decal With Soft Cotton Cloth.
6. When Decals Get Dry Then Complete.

水貼紙使用説明:

1. 將模型表面擦乾淨
2. 將貼紙剪下泡入清水中約15秒
3. 將泡濕之貼紙取出置於欲貼處旁
4. 用指尖輕推貼紙表面使其滑出底紙
5. 將貼紙調整至適當位置並輕擦拭水份
6. 待其自然乾燥後即完成

Color list: 塗料表

Color	Brand	Gunze Sangyo			Humbrol	Revell
		Hobby Color	Mr. Color	Mr. Color Spray		
Olive Drab	橄欖綠	H-78	C-38	J-38	116	46
Olive Green	橄欖綠		C-120		30	361
Dark Green	濃綠色 (陸上自衛隊色)		TC-07			
Brass	黃銅	H-9	C-9	J-9	54	92
Silver	銀	H-8	C-211	J-8	11	90
Steel	黑鐵	H-18	C-28	J-28	53	91
Olive Drab(2)	橄欖綠	H-304	C-304		161	361

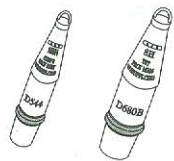

®
AFV CLUB HOWITZER ROUND STOWAGE CASE
AF 35017

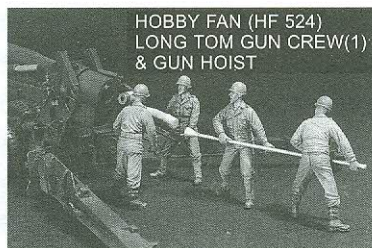

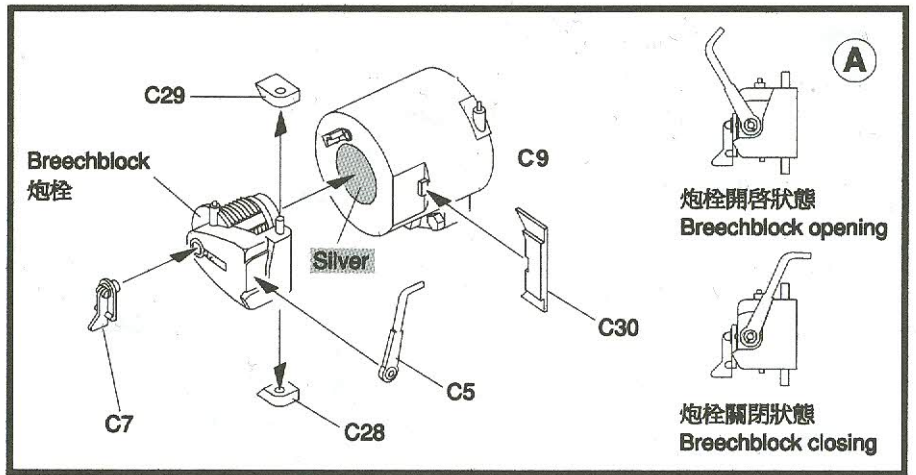
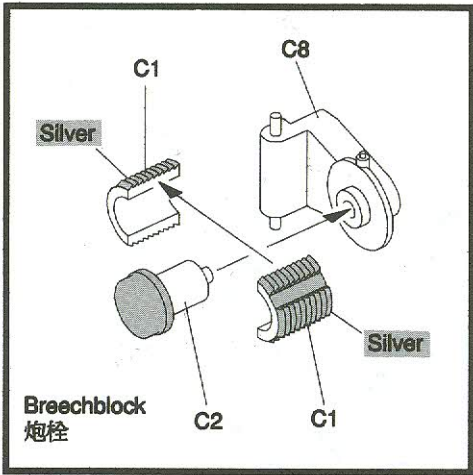

1

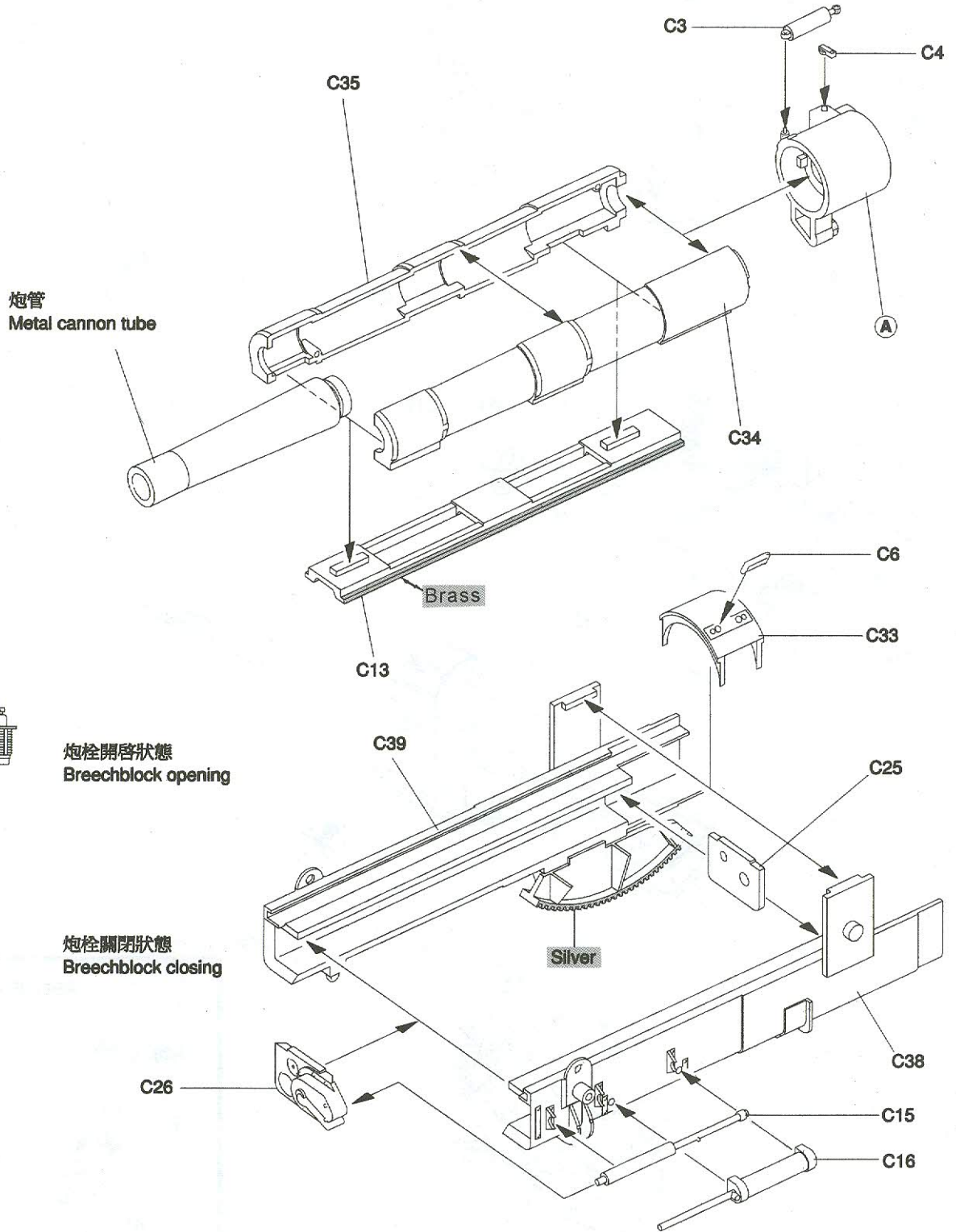

2

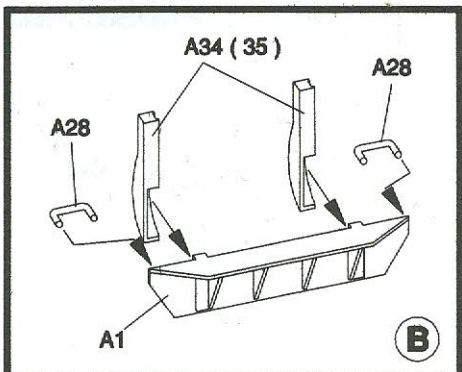
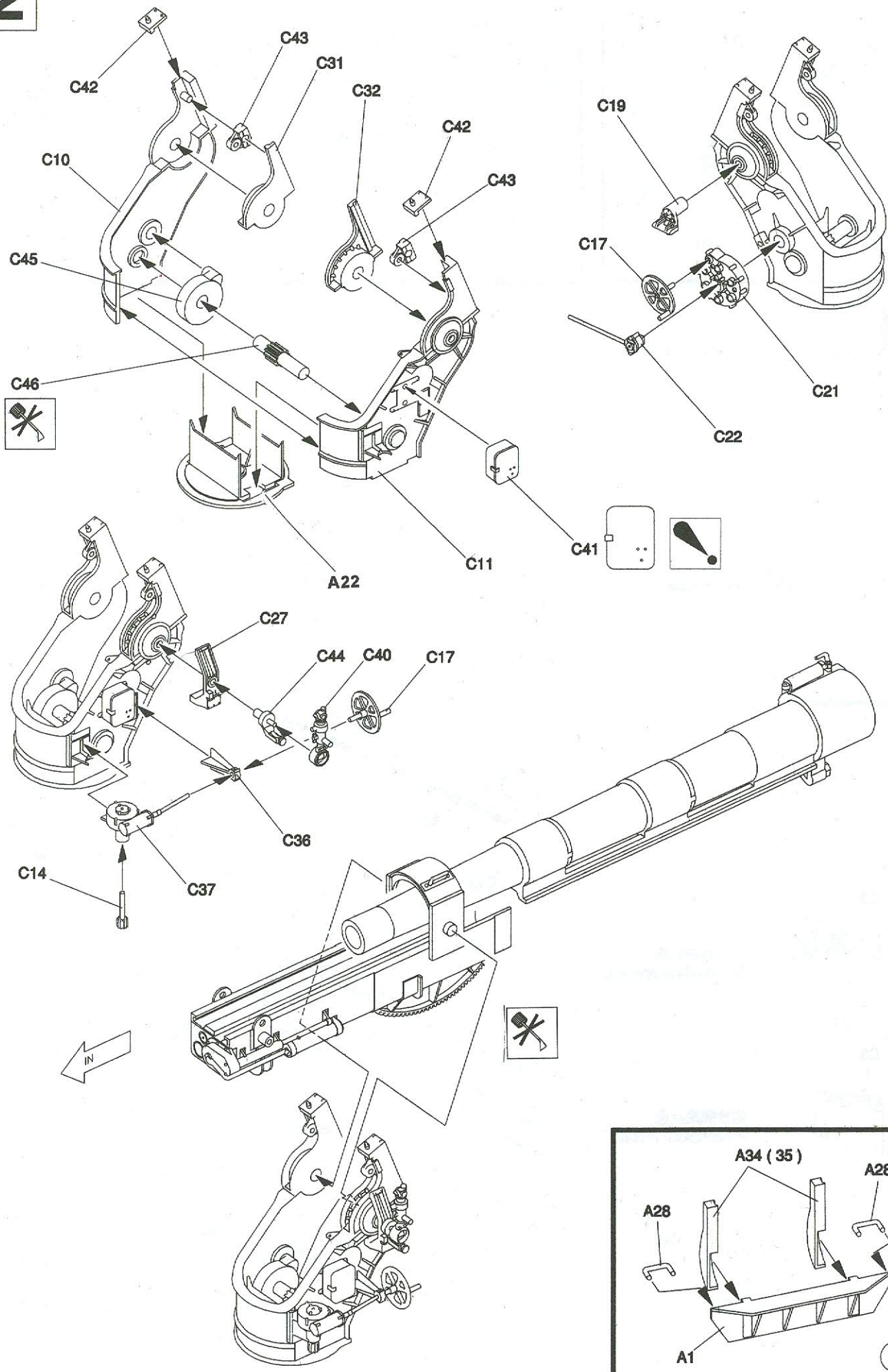

3

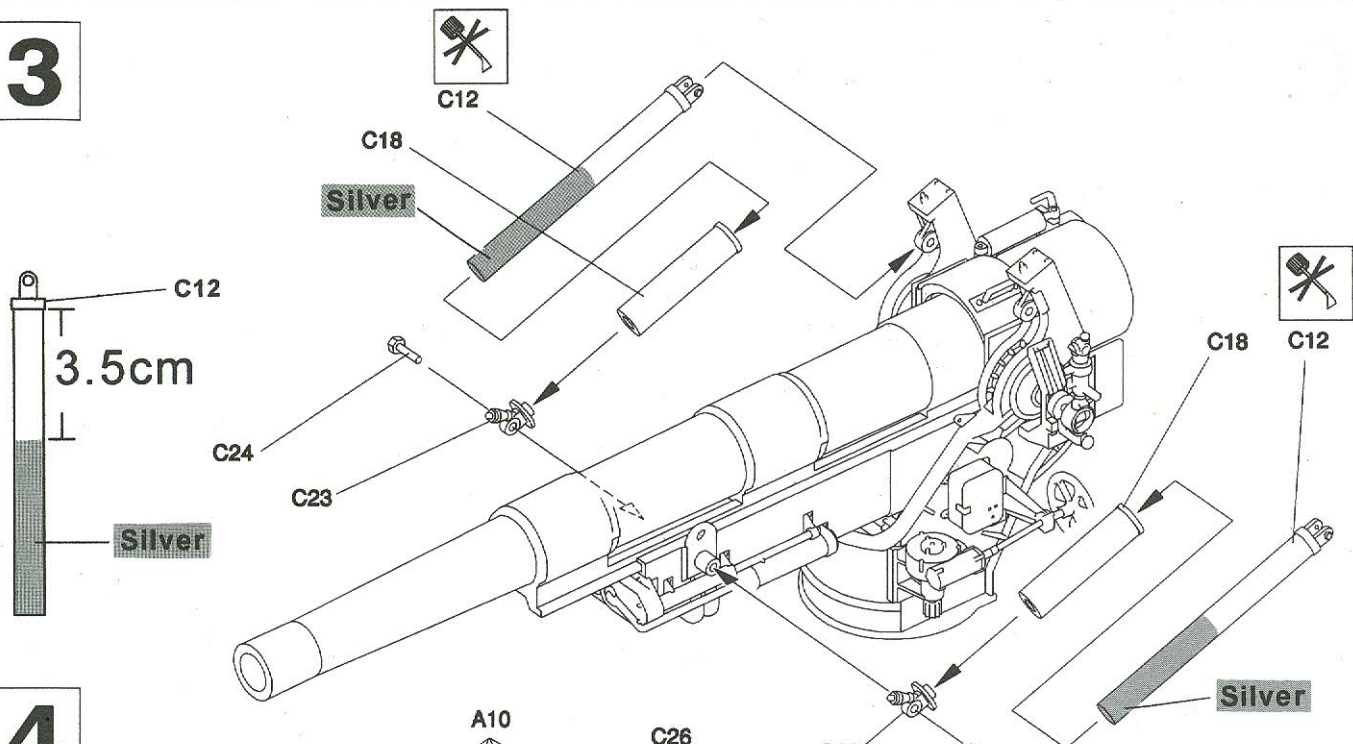

4

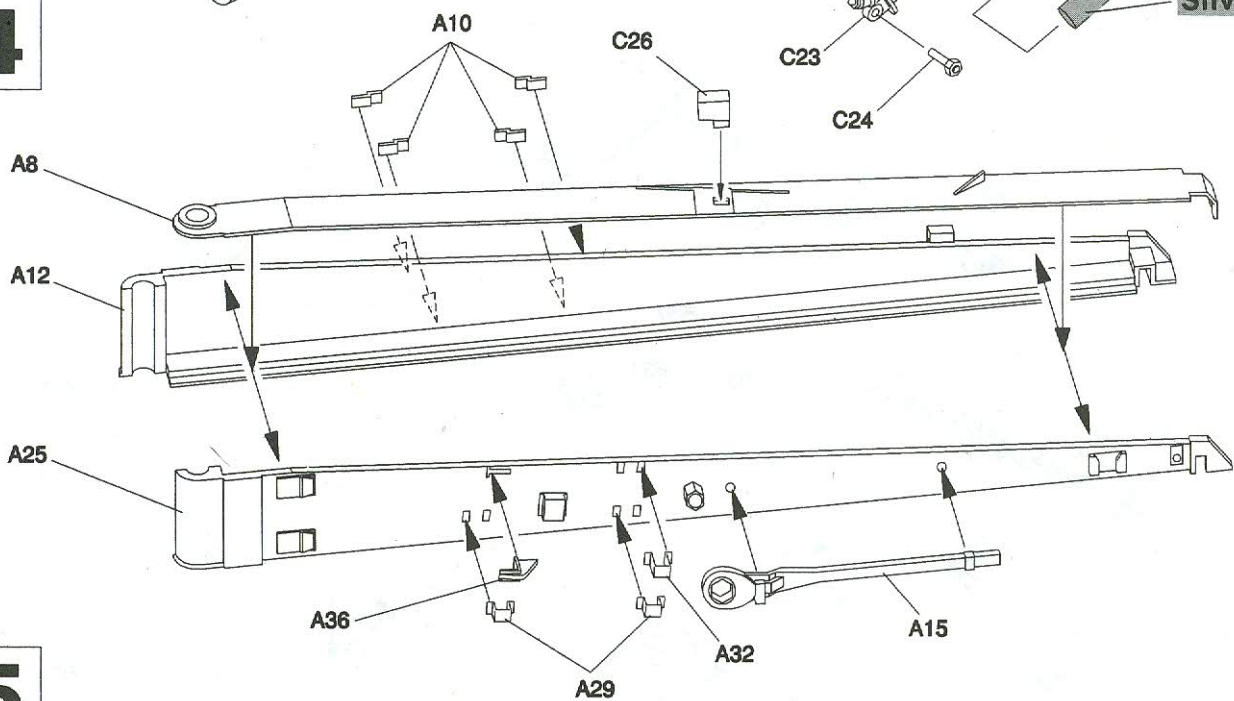

5

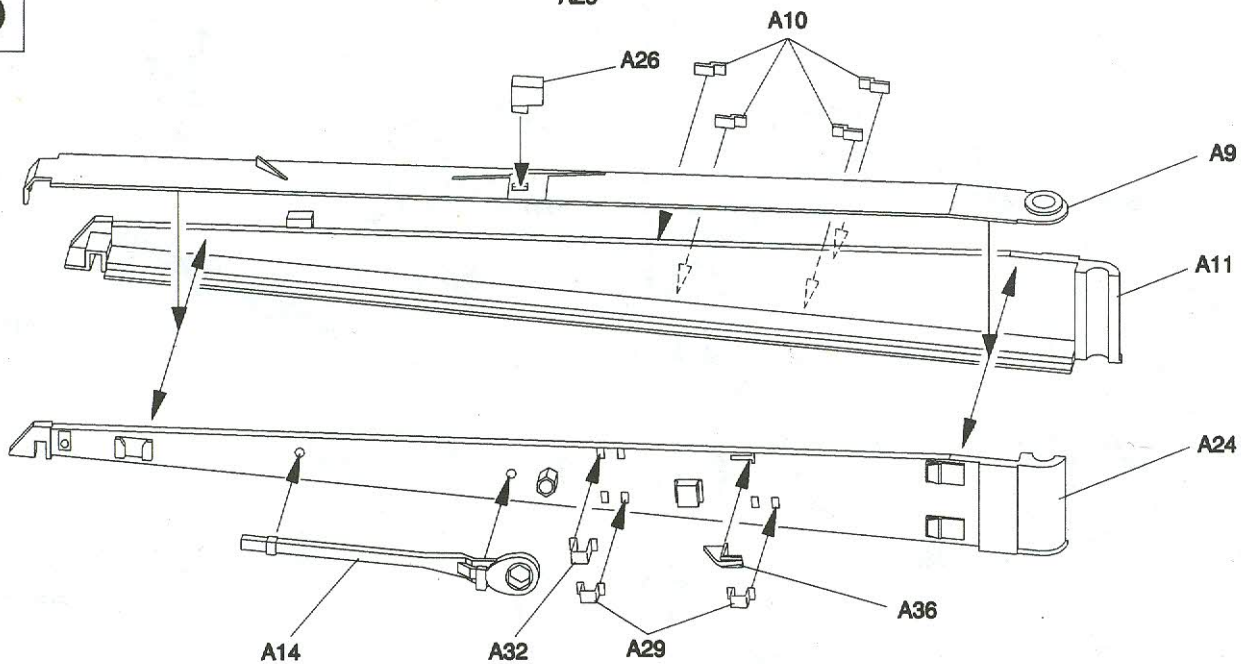

8

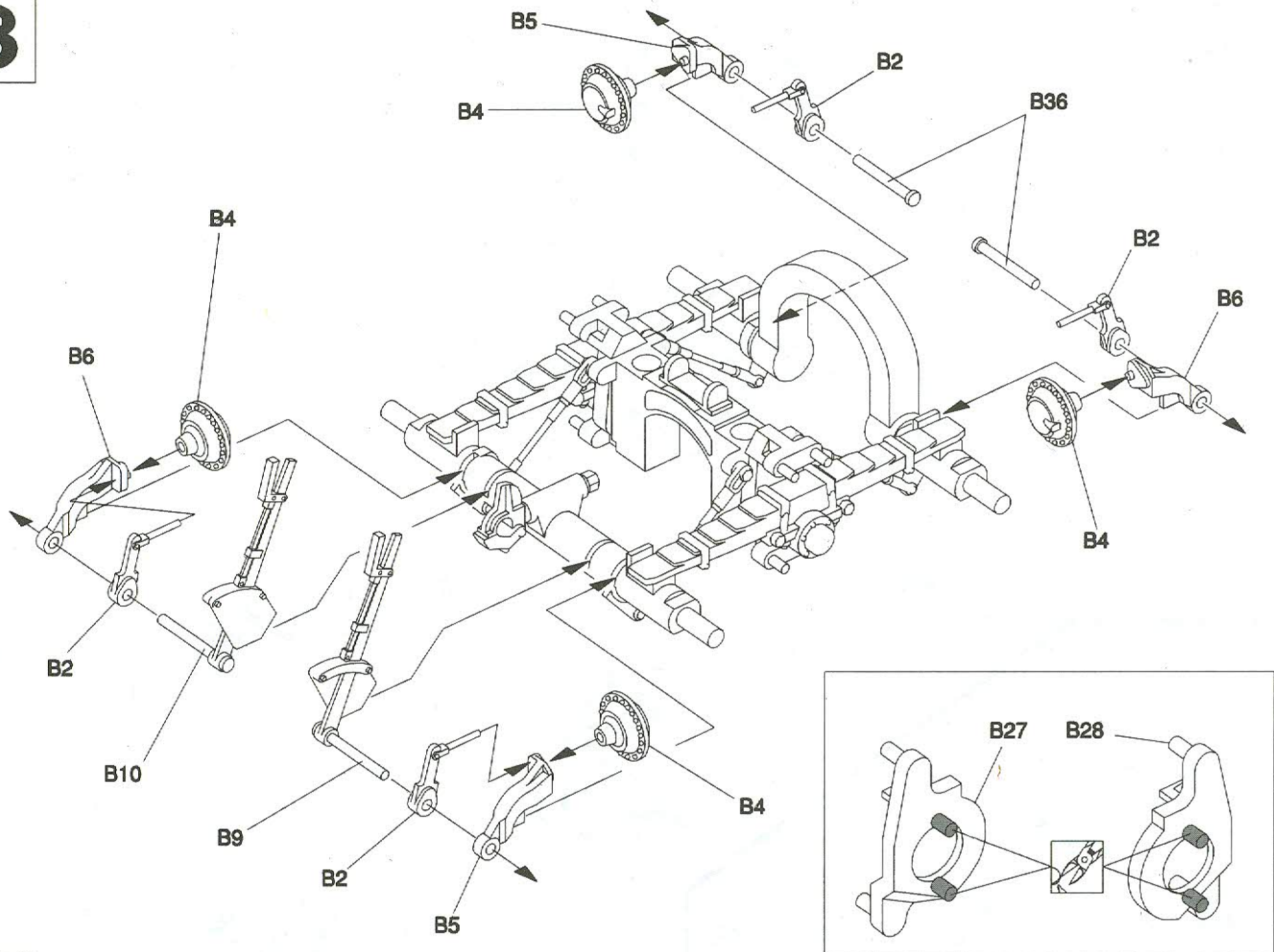

9

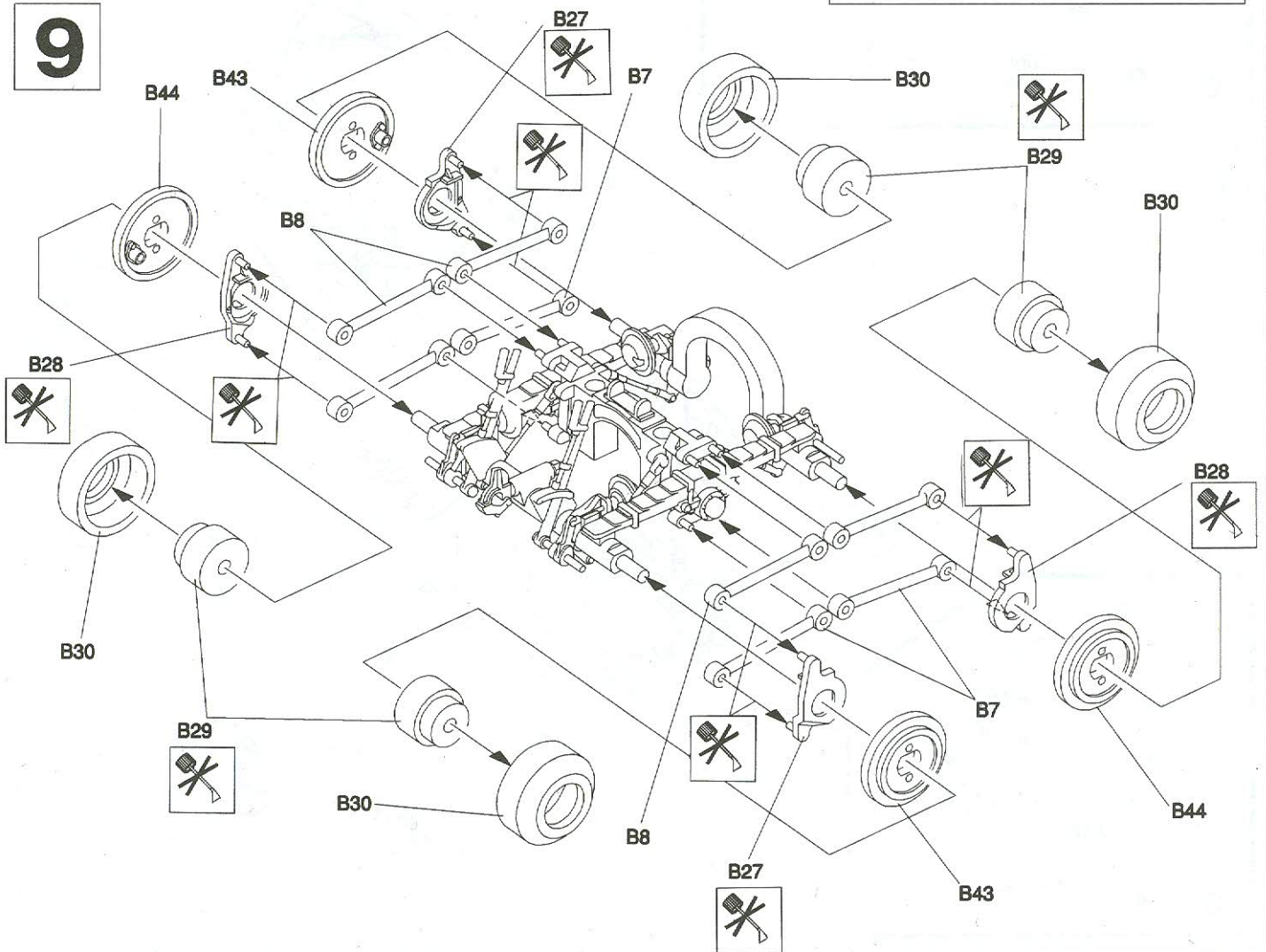

10

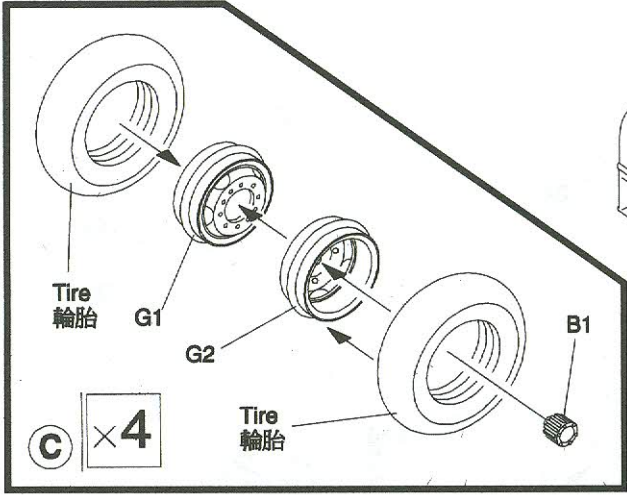
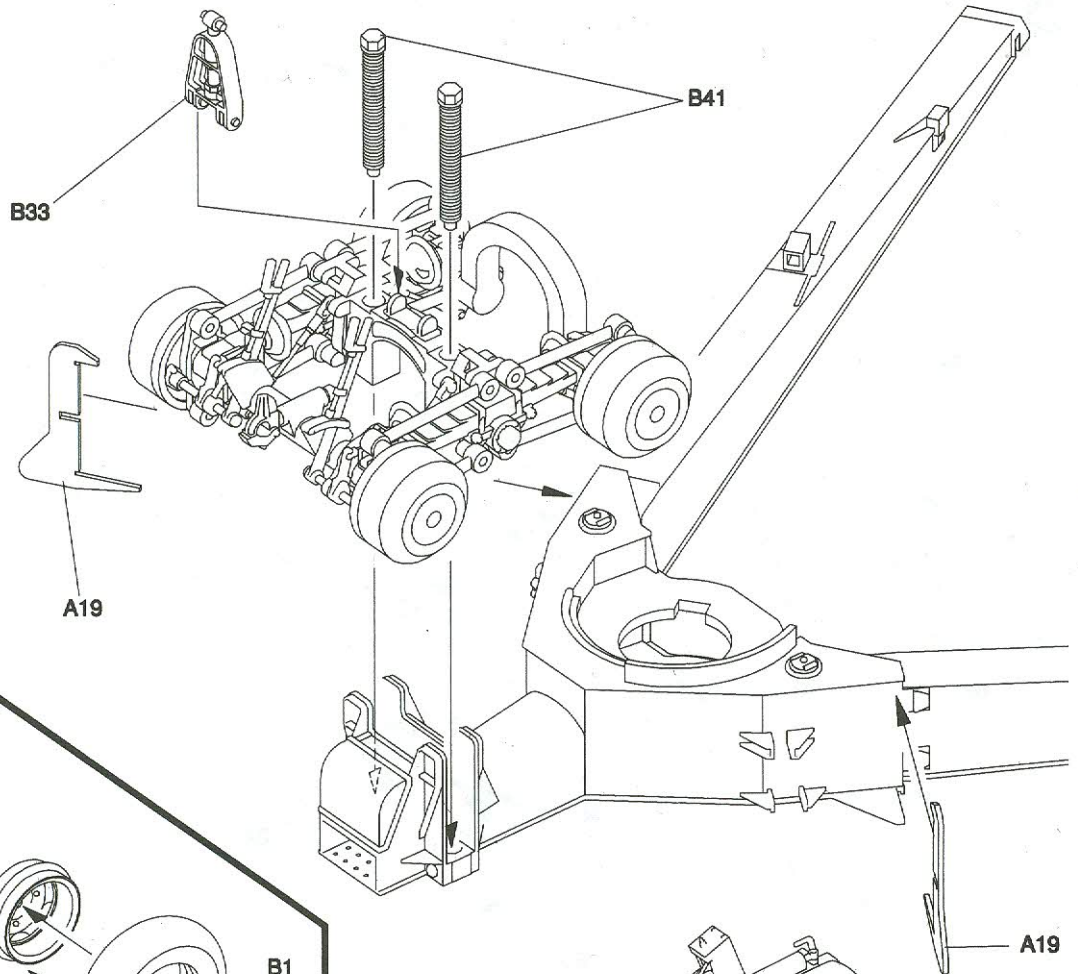

11

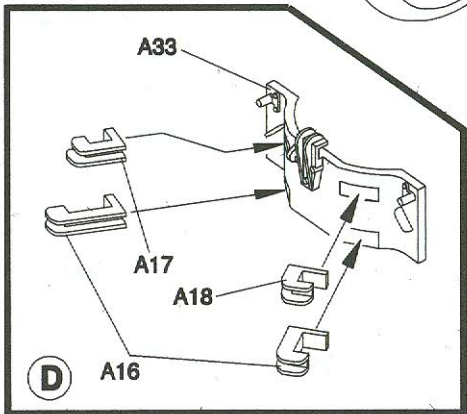
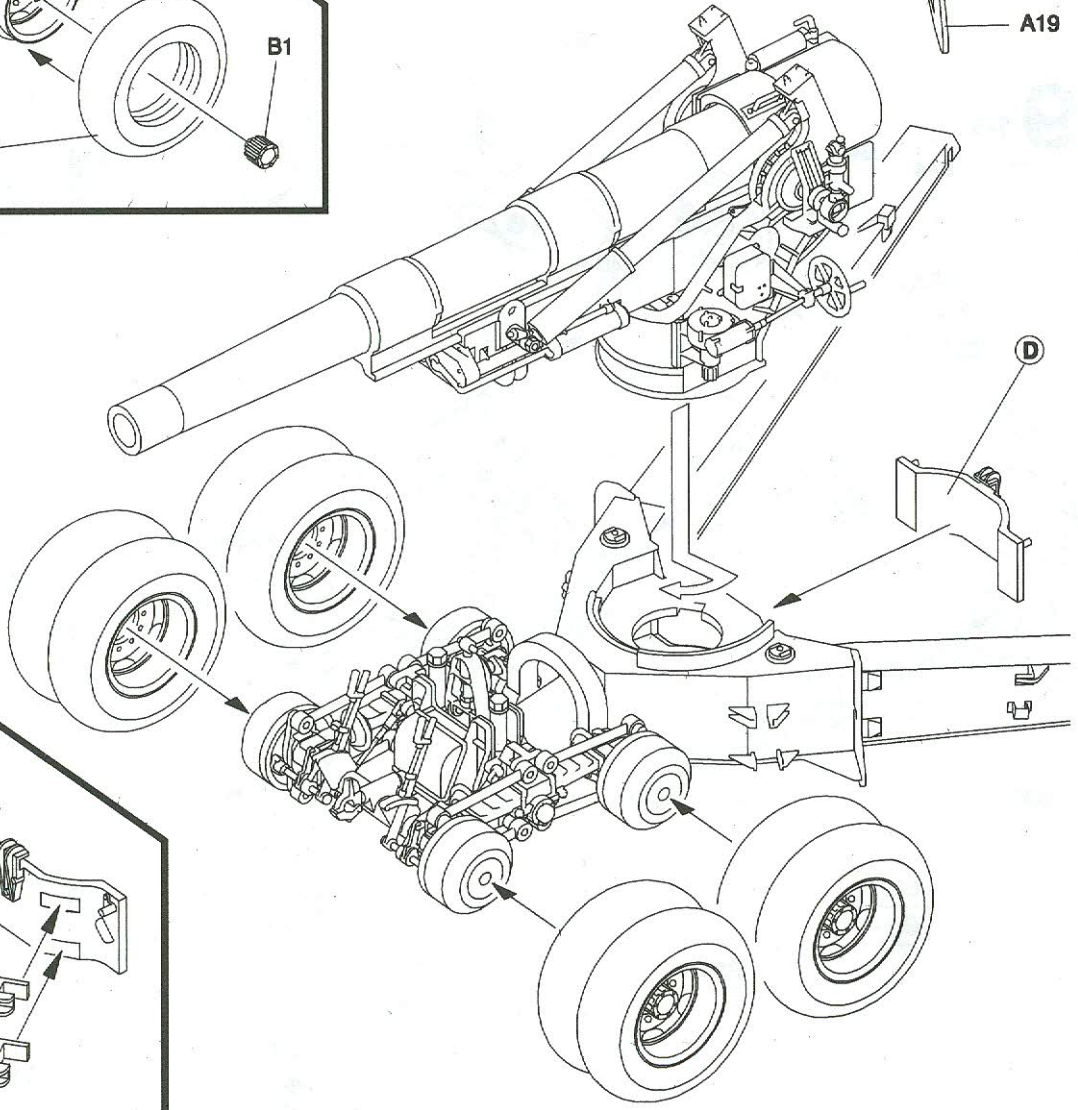

12

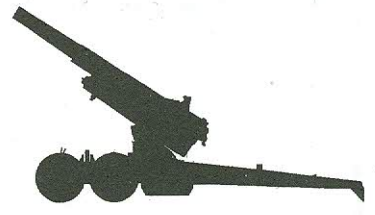

Fire-position
射擊狀態

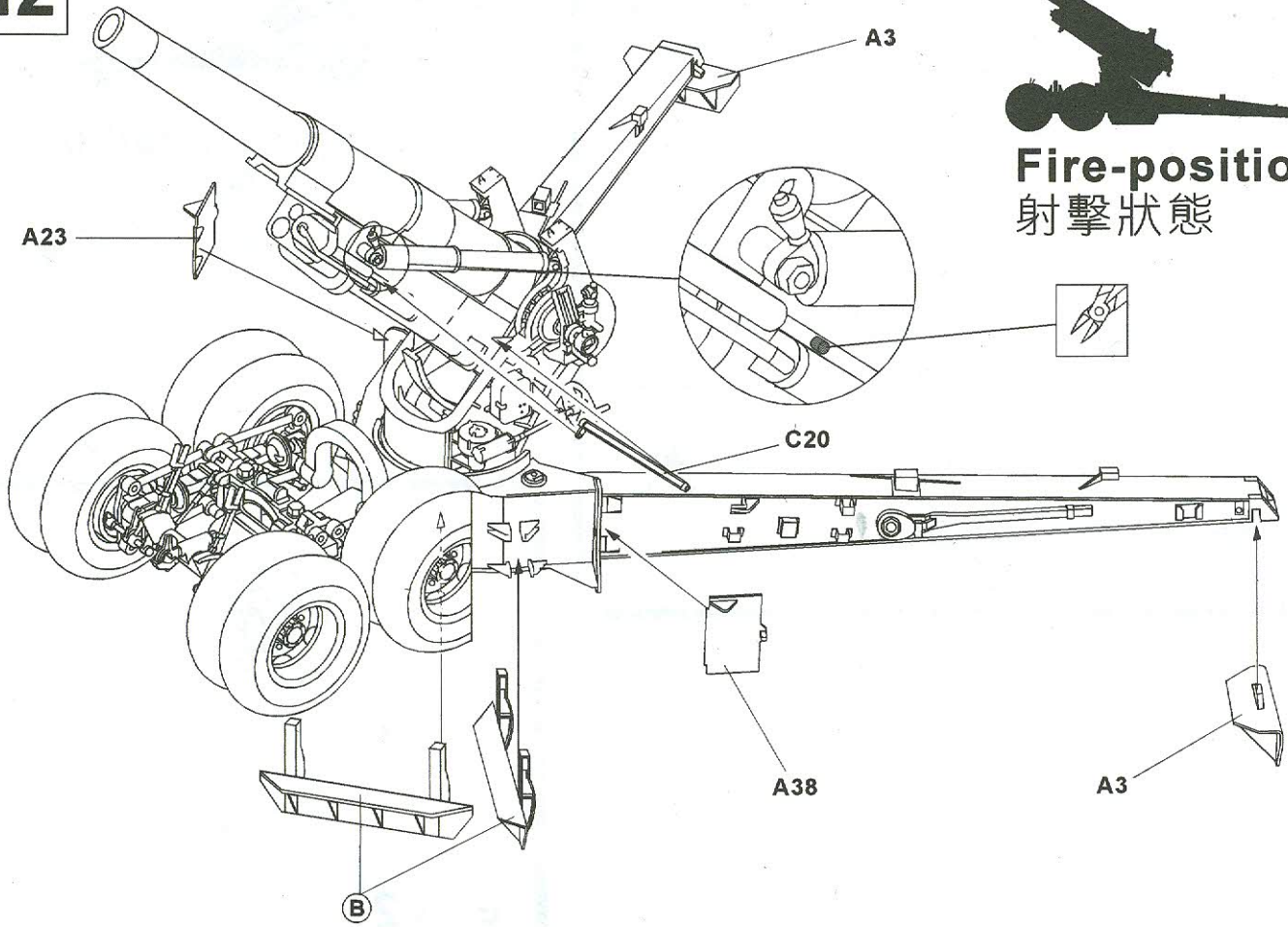

13

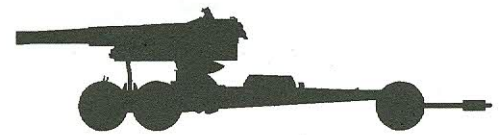

Transport position
運輸狀態

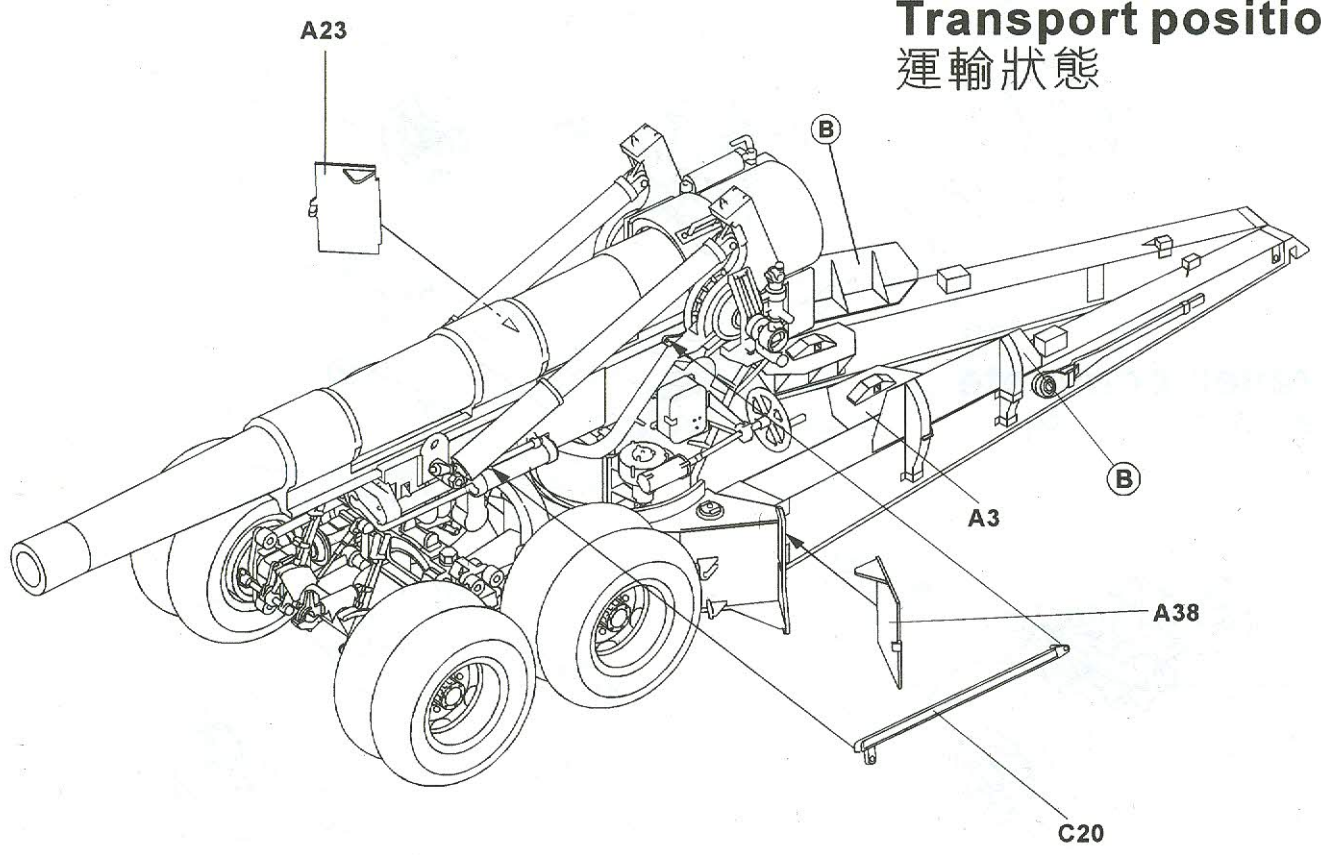

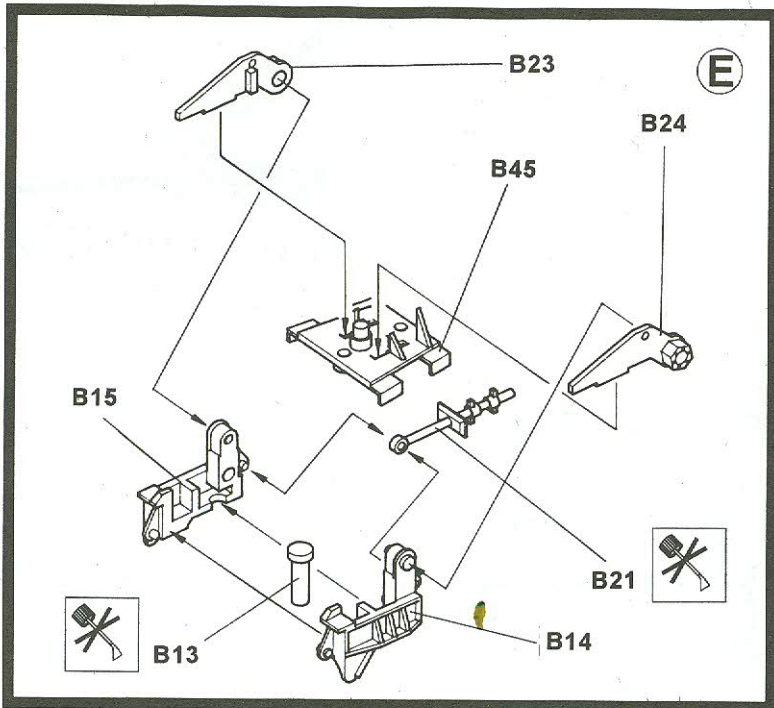

Transport position
運輸狀態

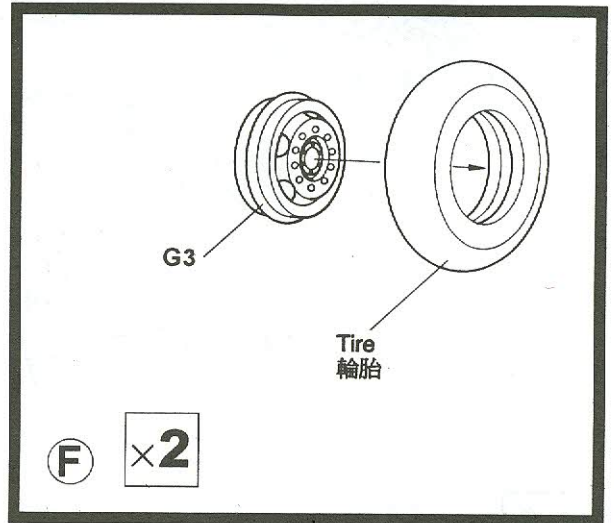
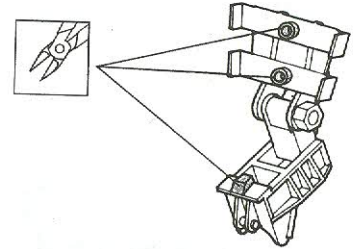

14

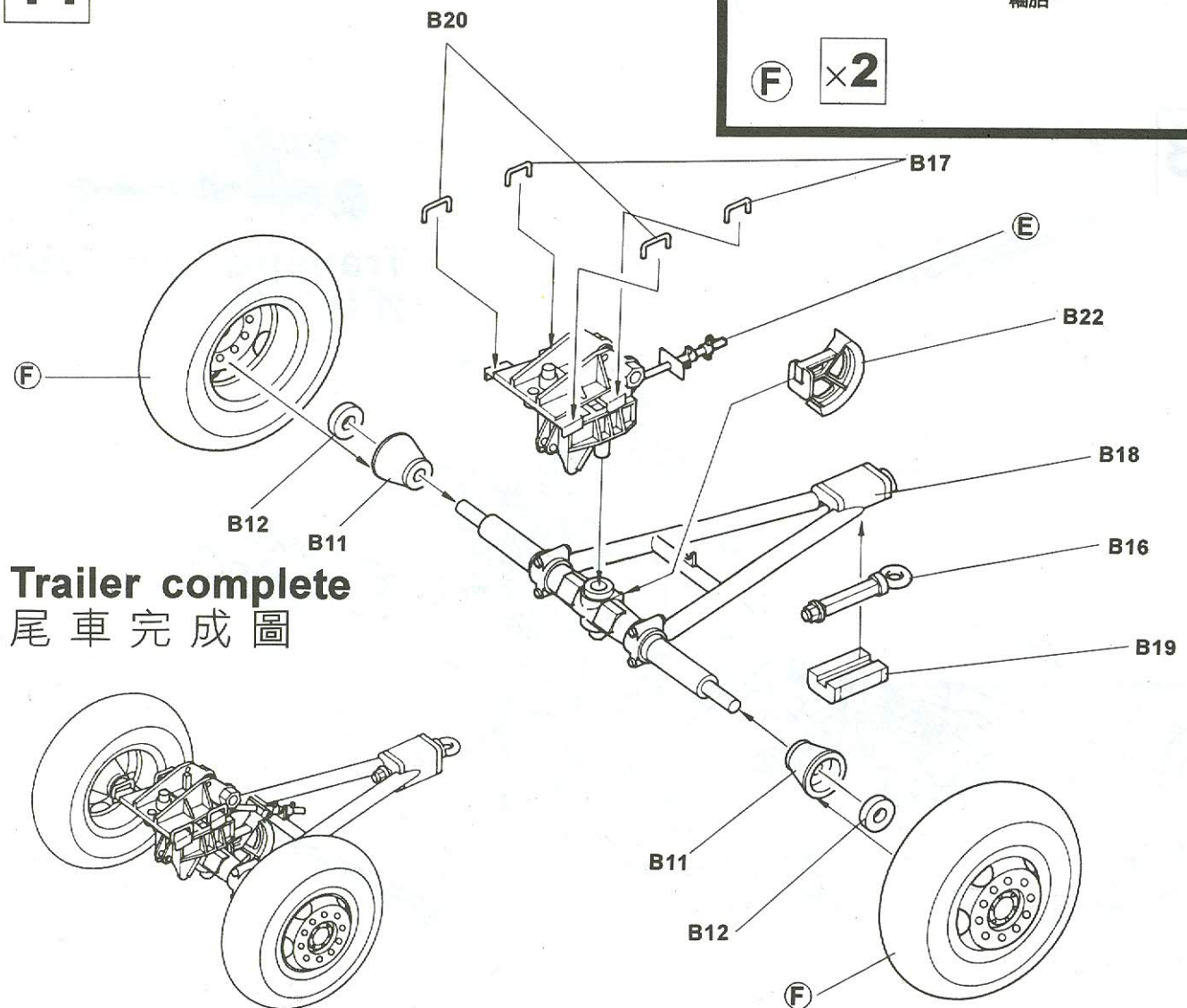

Trailer complete
尾車完成圖



Transport position
運輸狀態

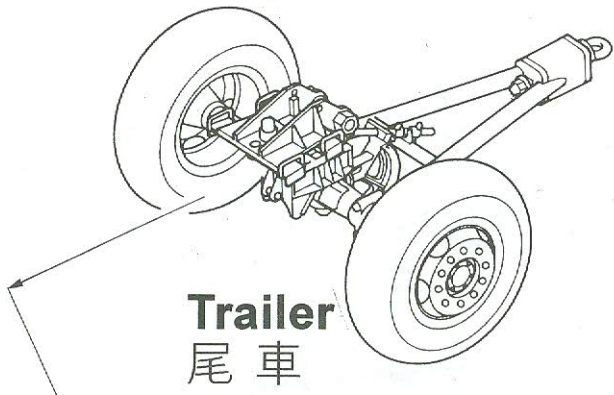

Trailer
尾車

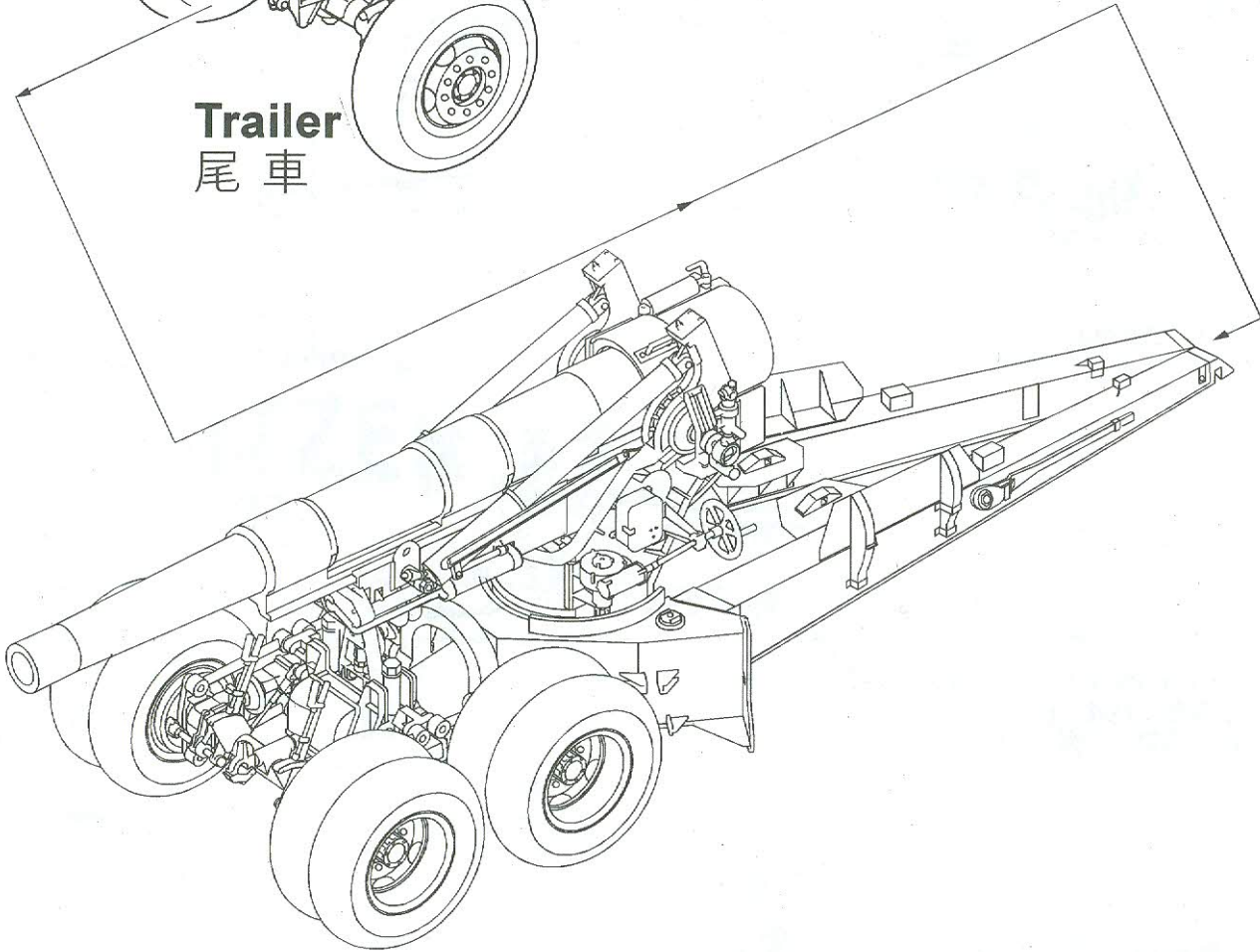

Transport position complete
運輸狀態完成圖

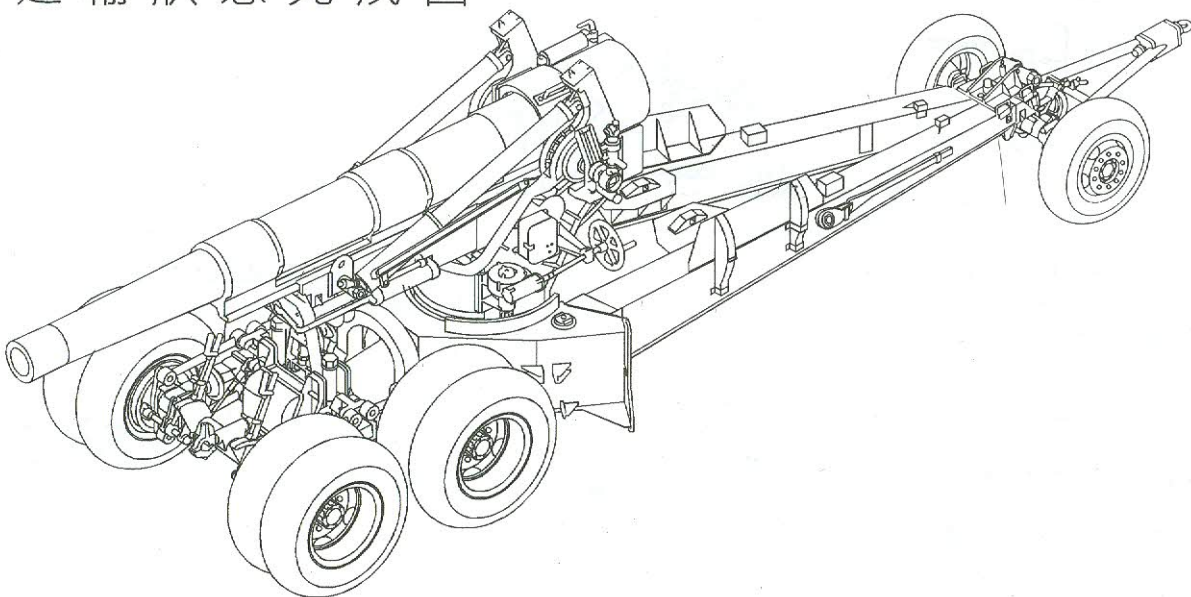

- ① U.S. army. Brittany, France, 1944
 美國陸軍. 1944年, 法國, 不列塔尼
 アメリカ陸軍 フランス、ブルターニュ 1944年



Body Color: Olive Drab(2)

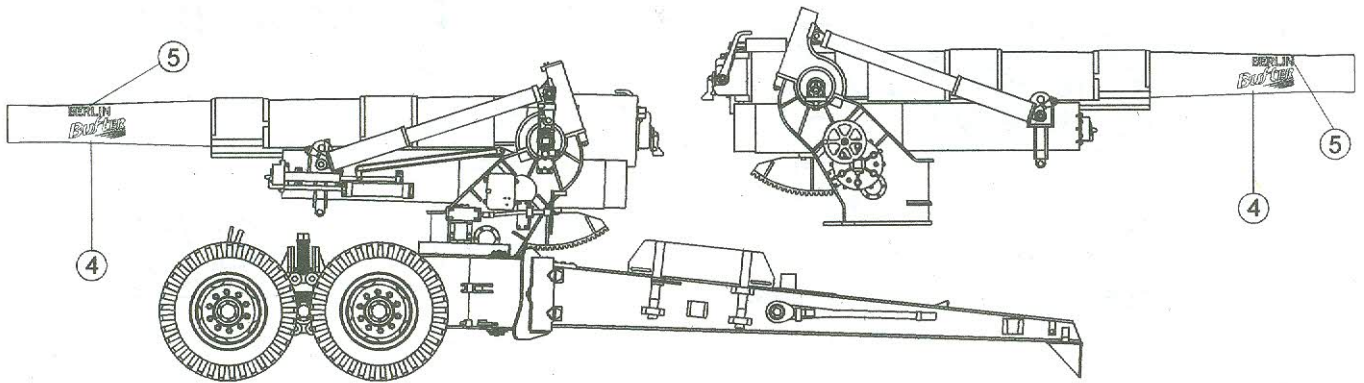

- ② U.S. army. German, 1945
 美國陸軍. 1945年, 德國
 アメリカ陸軍 ドイツ 1945年



Body Color: Olive Drab(2)

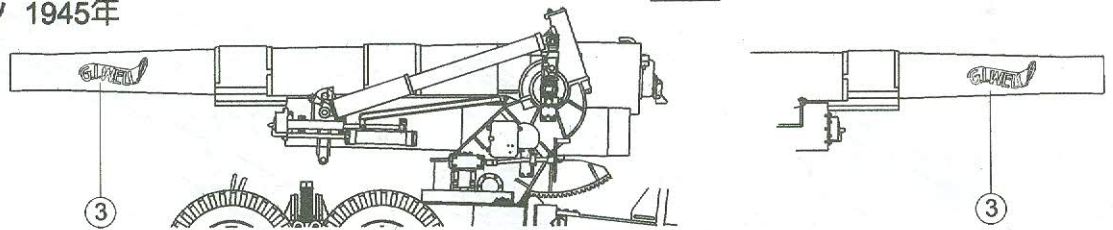

- ③ U.S. marine corps. Okinawa, 1945
 美國陸戰隊. 1945年, 琉球
 アメリカ海兵隊 沖縄 1945年



Body Color: Olive Drab

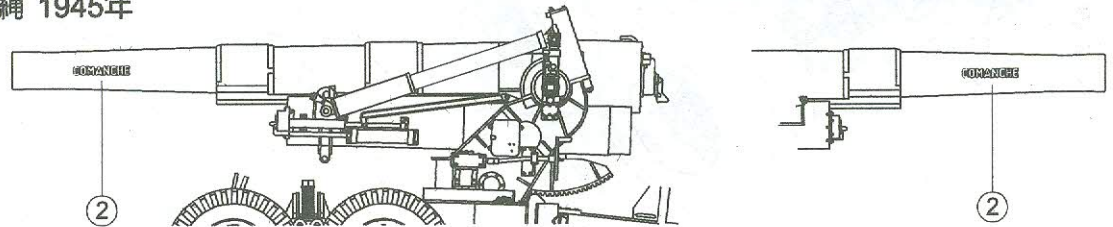

- ④ U.S. army (UN forces). Korean, 1951
 美國陸軍(聯合國軍). 1951年, 朝鮮
 アメリカ陸軍(国連軍) 韓国 1951年



Body Color: Olive Drab(2)

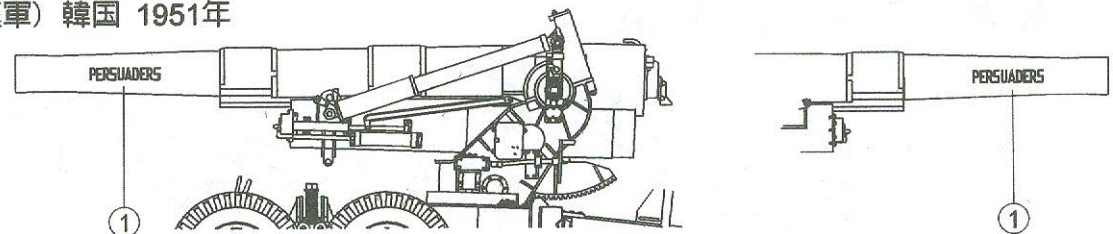

- ⑤ R.O.C. army. Jinmen island 1958~
 中華民國陸軍. 1958年~, 福建省金門縣
 中華民國陸軍 金門島 1958年~



Body Color: Olive Green

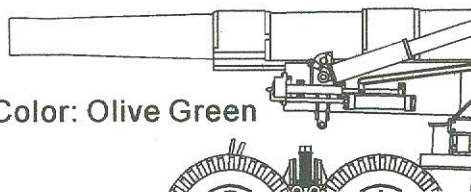

- ⑥ Japan ground self defense force
 日本陸上自衛隊



Body Color: Dark Green

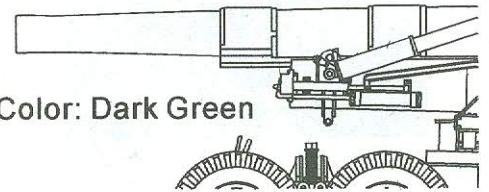

Parts list: 零件表

(A)

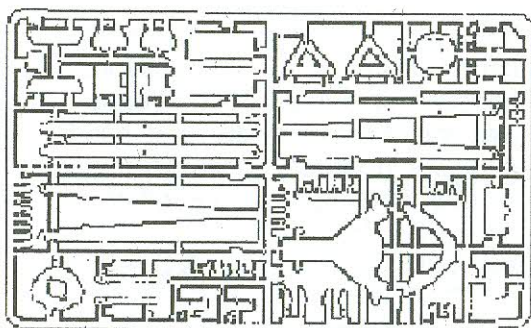

(B)

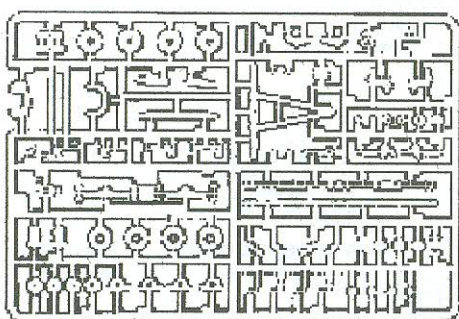

(C)

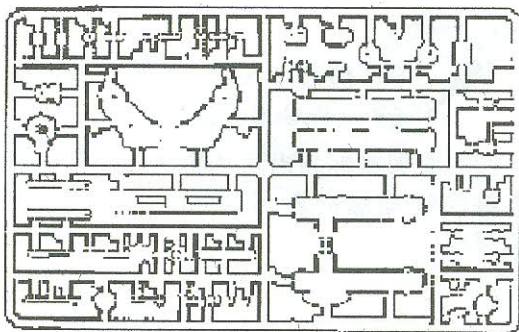

(G)

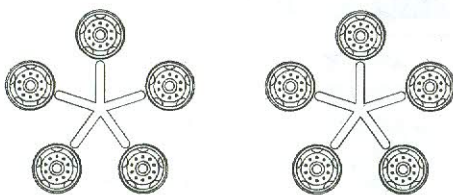

Tire
輪胎

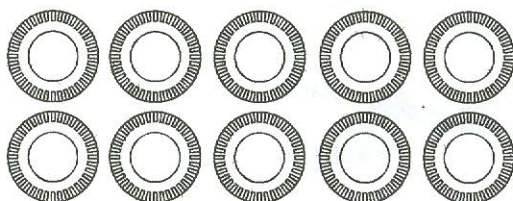

Gun tube
砲管



Decal
貼紙





Instruction:

If for some reason, you are not fully satisfied or have questions concerning our product; Please use the form provide, and send it to our nearest representative or mail it directly to our office.

We will deal with that A.S.A.P.

	AF 35S06 Parts Replacement Form
<input type="checkbox"/> A parts	<input type="checkbox"/> Gun tube
<input type="checkbox"/> B parts	<input type="checkbox"/> Decal
<input type="checkbox"/> C parts	
<input type="checkbox"/> G parts	
<input type="checkbox"/> Tire	
Reason for replacement: <input type="checkbox"/> Missing	
<input type="checkbox"/> Broken	
Signature: _____	



**零件補充表內價格限國內地區有效
(For R.O.C. Use only)**

請將本表與該部品相同金額之郵政匯票一同寄至總代理:戰鷹企業 客服部收,本公司將盡速為您辦理!

	AF 35S06 零件補充申請表	申請人 姓 地 電 名 址 話
<input type="checkbox"/> A部品零件 ----NT\$ 150	
<input type="checkbox"/> B部品零件 ----NT\$ 250	
<input type="checkbox"/> C部品零件 ----NT\$ 60	
<input type="checkbox"/> G部品零件 ----NT\$ 280	
<input type="checkbox"/> 輪胎 ----NT\$ 160	
<input type="checkbox"/> 砲管 ----NT\$ 120	
<input type="checkbox"/> 貼紙 ----NT\$ 150	
+郵寄費 ----NT\$ 40		
(請填)總計 NT\$ _____		
零件補充原因:(請於 <input type="checkbox"/> 打 <input checked="" type="checkbox"/>)		
原包裝即 <input type="checkbox"/> 遺失或 <input type="checkbox"/> 毀損.		
製作途中 <input type="checkbox"/> 遺失或 <input type="checkbox"/> 毀損.		
<input type="checkbox"/> 補充多餘零件.		
其它原因 _____		