

# Korean War Sea Fury “海怒” 战斗机

"Sea Fury" was a kind of carrier-based fighter which was investigated and produced by the Great Britain during the World War II. It had used folding wing of "Tempest". The fuselage was even smaller and lighter. Totally 860 aircrafts had been produced. All of them were being used to equip the British Royal Navy. In 1949, it set a speed record flying from London to Rome and proved itself to be a good long-range fighter.

**Range: 740km, Maximum speed: 740km/h, Ceiling: 10,910m, Wing span: 11.70m,**  
Length: 10.60m, Height: 4.90m

“海怒”是英国在第二次世界大战中研制的一种舰载战斗机。使用“Tempest”的可折叠机翼，机身更小、更轻。共生产860架，全部装备英皇家海军。

航程：740km 最大速度740km/h 升限：10,910m，翼展：11.70m 机长：10.60m 机高：4.90m



**Attention-Useful Advice**

1. Study the instructions carefully prior to assembly.
2. Check the fitness of each part before assembling.
3. Remove parts from frame with a sharp knife or a pair of scissors and trim away excess plastic. Be careful, do not break off any plastic parts.
4. Don't pull off the parts from frame.
5. Use plastic cement only and use cement sparingly to avoid damaging the model.
6. Paint small parts before detaching them from frame.
7. Remove paint where parts are to be cement.
8. Parts with shadows are not used for this model.

**CAUTION**

1. Before you start assembly, you should read all the instructions carefully.
2. Please have all the necessary tools ready before start assembling.
3. The removed plastic parts have sharp, pointed or jagged edges. Remove these with a file or sandpaper.
4. Do not use glue or paint near open flame. Keep the window open.
5. Plastic bags can be dangerous. To avoid danger of suffocation, keep this bag away from babies and children.
6. Keep out of the reach of children under 36 months old, as some parts are detachable. Children must not be allowed to suck any parts with this kits.
7. Please keep this instructions for future reference because it contains important information.

**注意：拼装技巧提议**

1. 拼装之前请小心阅读说明书。
2. 拼装之前请检查每部份零件是否吻合。
3. 请用小切刀或模型剪从注塑件中剪去多余的胶片，请小心，勿剪断塑胶零件。
4. 切勿从塑胶片中拉断零件。
5. 请使用模型专用胶水粘接，小心使用胶水以免损坏模型。
6. 请先替小零件涂上颜色，然后将小零件从塑胶片中取出。
7. 请刮去零件要沾合处的油漆。
8. 阴影部分的零件不是作为装配此模型之用。

**小心：**

1. 请在拼装之前，小心阅读所有说明书。
2. 请在拼装之前，准备好所需工具。
3. 移去的塑胶零件会有尖锐的锯齿状的边缘，用小挫子或沙纸磨掉。
4. 切勿在火旁使用胶水或油漆，应保持窗户通风。
5. 胶袋可以造成危险，为避免窒息，请勿让婴儿及小孩接触此胶袋。
6. 由于部分零件是可以分开的，切勿让3岁以下小孩接触。禁止让此模型的零件让小孩含入口中。
7. 请保留此说明书作为将来参考之用，因为此说明书包含重要资料。

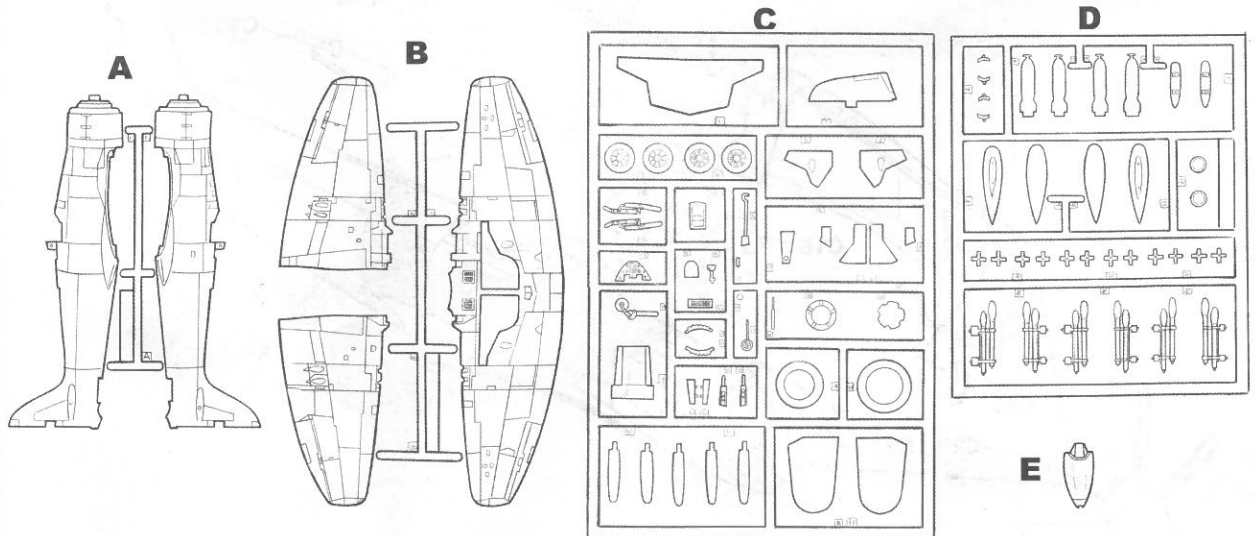

1

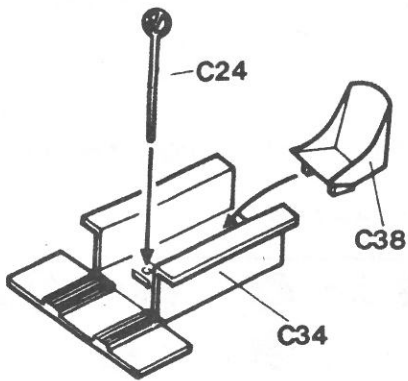

2

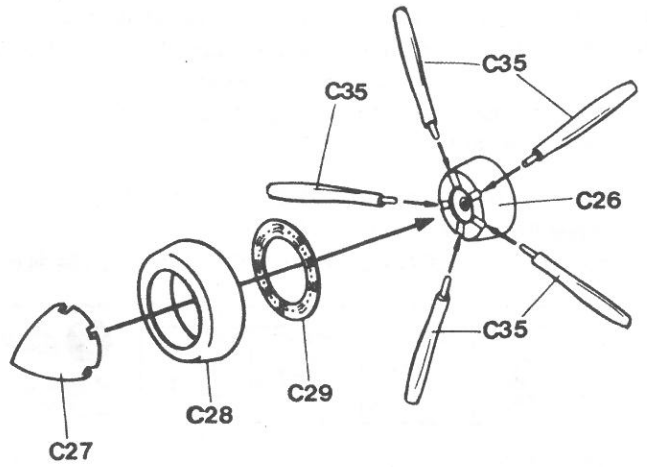

3

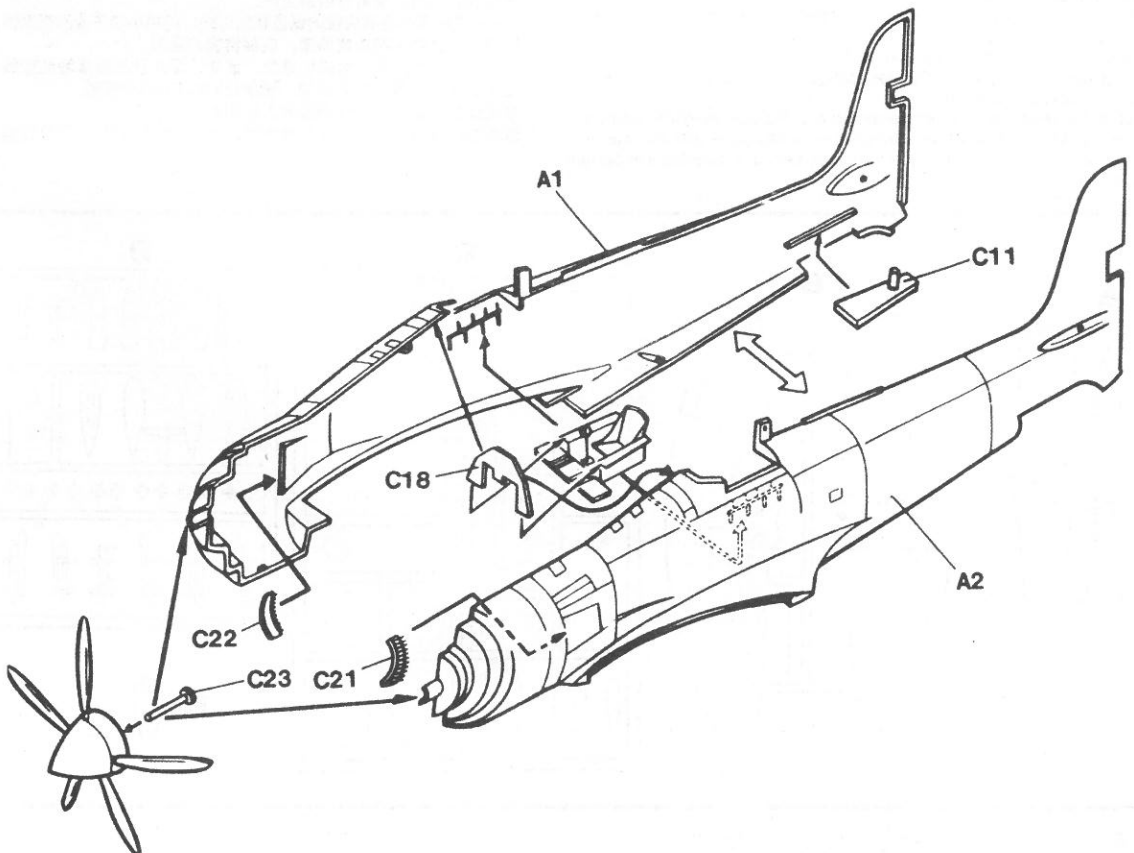

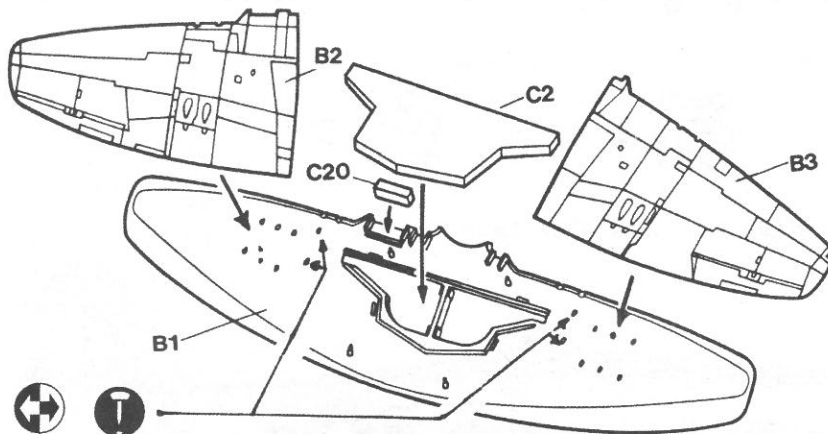
**4****5**

Drill small, angled hole in the top of the fin for part C13. See insert drawing

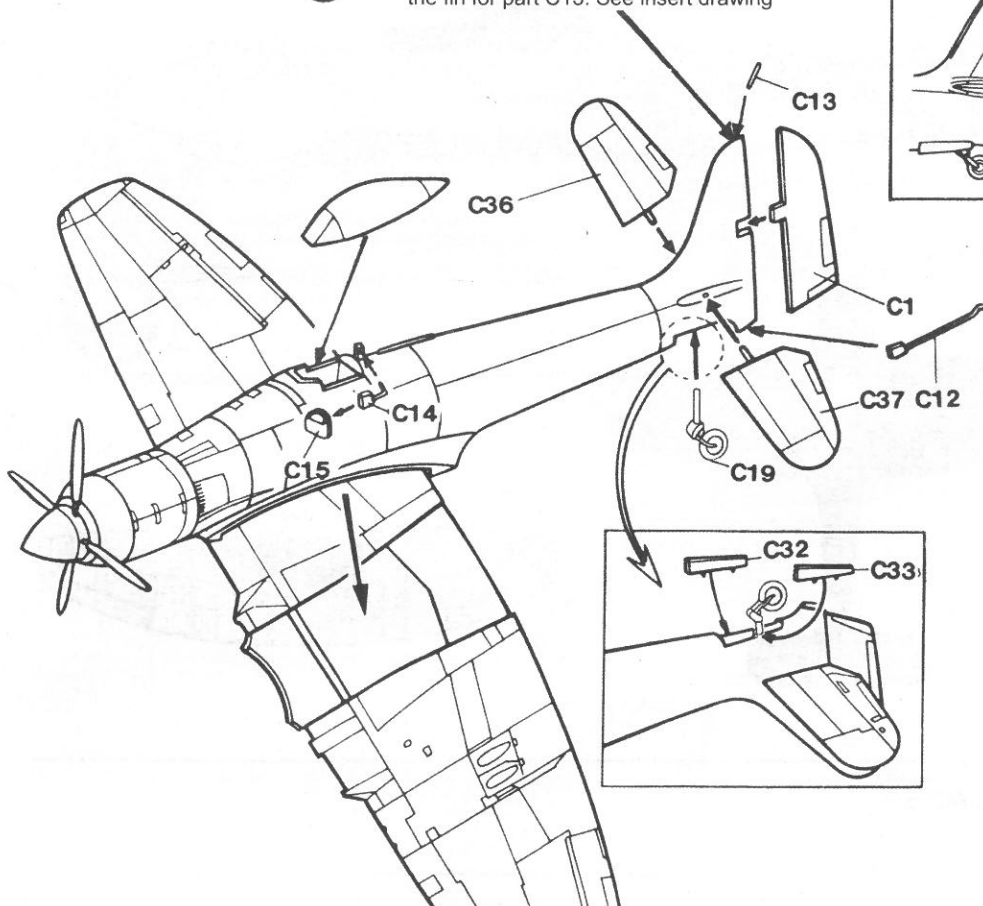
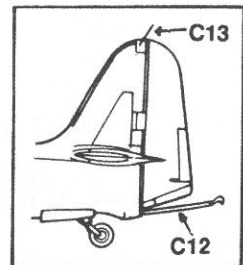

6

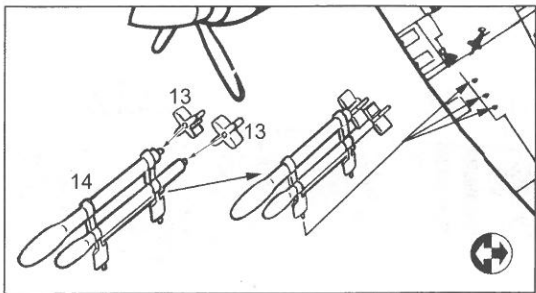
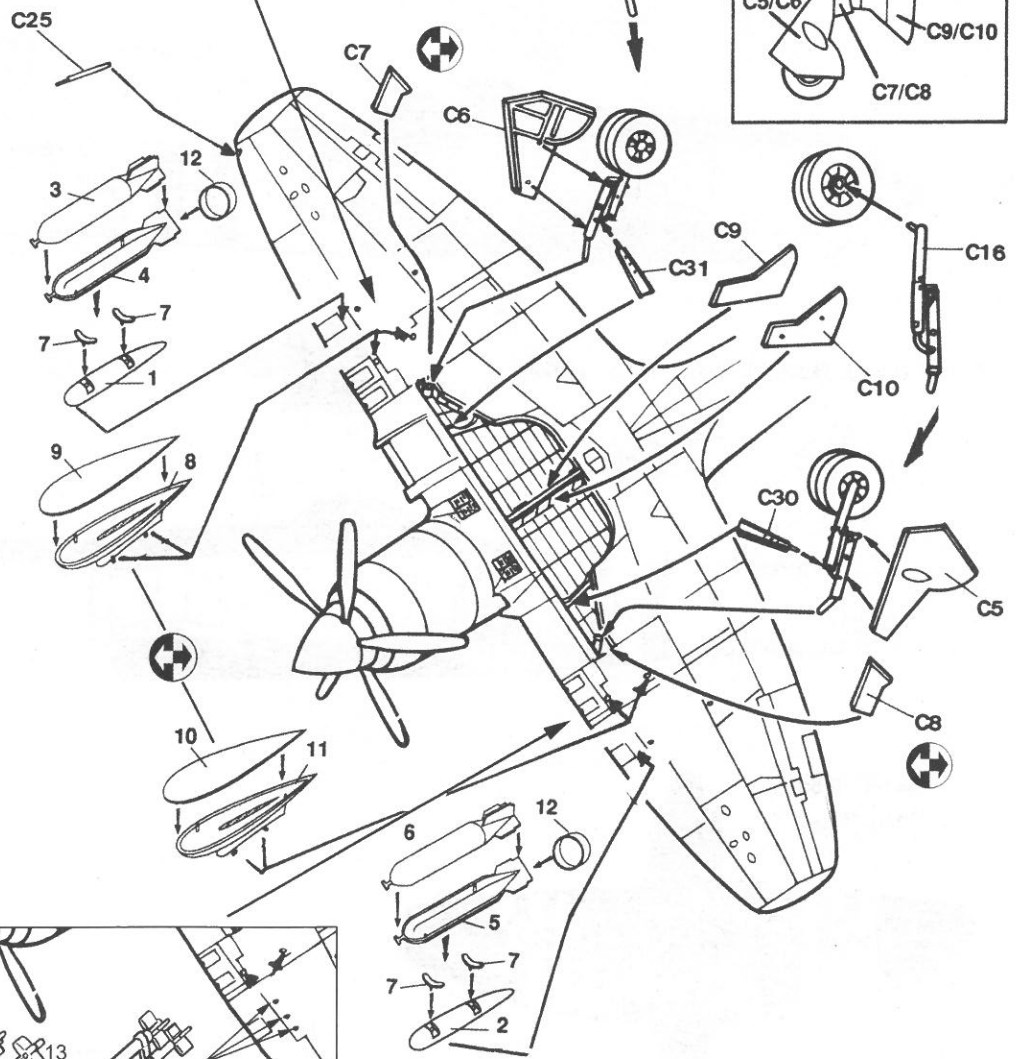
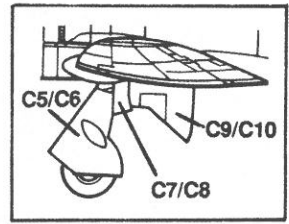
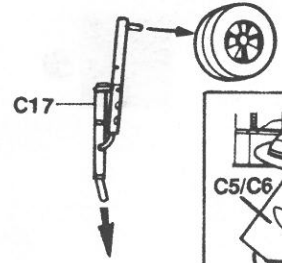
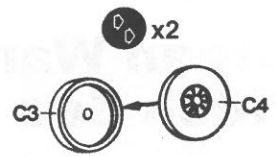
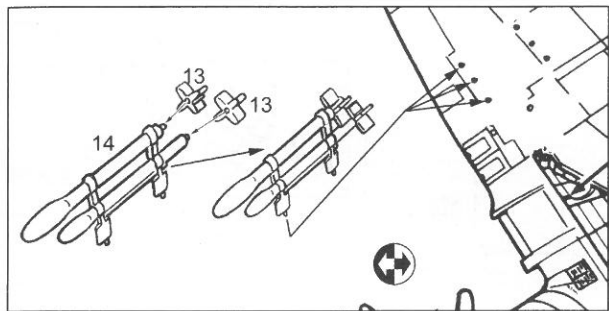

# Painting instruction 涂装指导

## Korean War British Sea Fury

### APPLYING DECALS

1. Cut off decal from sheet.
2. Dip the decal in tepid water for about 10 second place on a clean cloth.
3. Hold the backing sheet edge and slide decal onto the model.
4. Move decal into position by wetting decal with finger.
5. Press decal gently down with a soft cloth until excess water and air bubbles are gone.



印花(印花水贴纸)应用  
· 由印花纸剪下印花。  
· 将印花放入温水中约10秒, 然后放于干净布上。  
· 将印花移入模型上。  
· 手指沾水移放印花到位。  
· 用软布轻轻压印花直到水泡消失。



J4

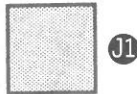

J1

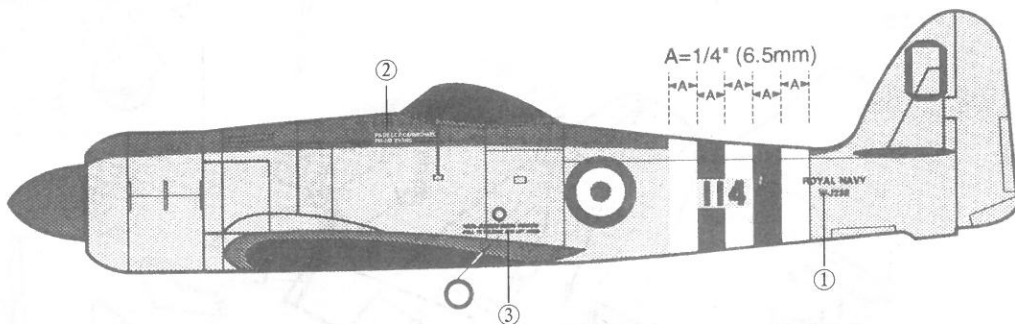

Royal Navy, No.802 Sqn., Aug. 1952

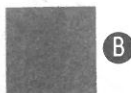

B

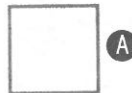

A

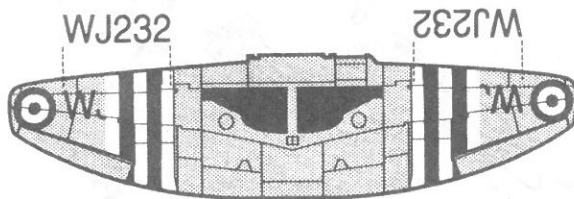
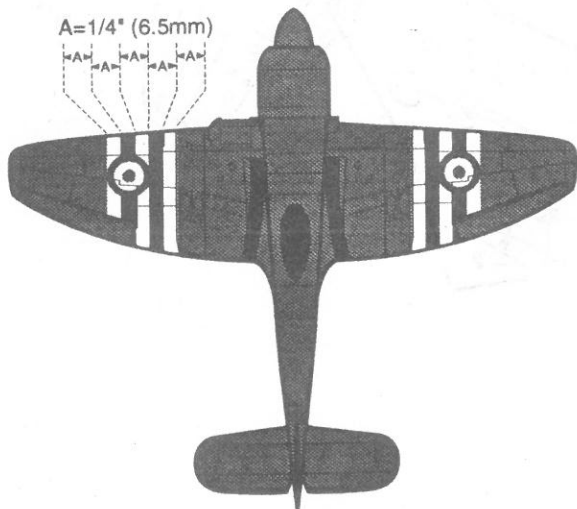
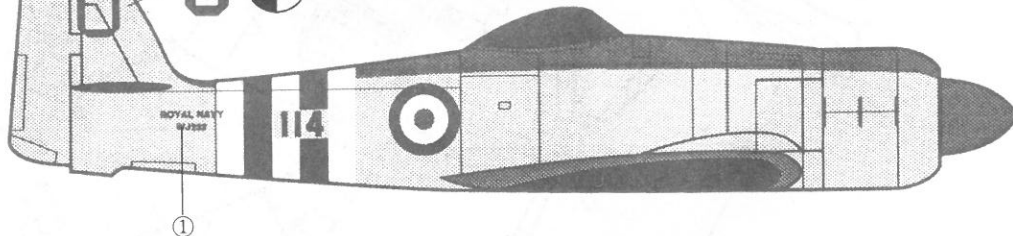

# Royal Dutch Navy Sea Fury



J4



J1

Royal Netherlands Navy, No.3 Sqn., Oct. 1955

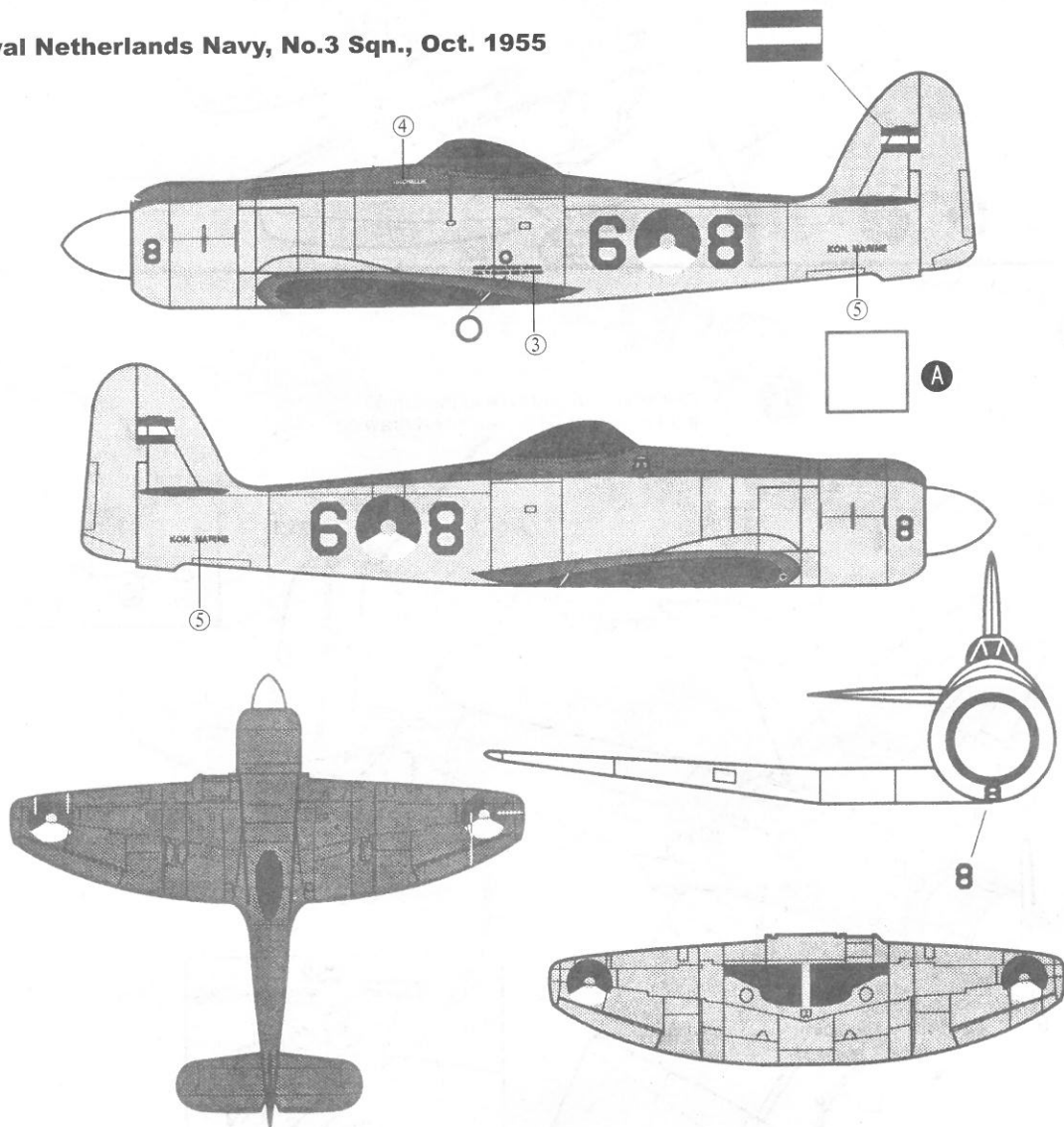

Colour Index Table 颜色指示

<p><b>A</b> White 白色</p>	<p><b>B</b> Black 黑色</p>	<p><b>J1</b> Light Ghost Gray 浅灰色</p>	<p><b>J4</b> Sea Gray 海灰色</p>
------------------------------	------------------------------	---	-----------------------------------