



L1500A с поднятым тентом Германский армейский автомобиль II MB

В конце 1941 г. компания Даймлер-Бенц разработала полноприводное шасси L1500A грузоподъемностью 1,5 т. Большая часть автомобилей получила открытый кузов для перевозки 7 человек (Kfz.70).

Всего было выпущено около 4900 автомобилей L1500A. Они показали себя прочными и надежными машинами.

Автомобили L1500A применялись всеми родами войск Германии на протяжении всей войны повсеместно – на советско-германском фронте, в Северной Африке, Италии, Франции.

Тактико-технические характеристики автомобиля L1500A (Kfz.70) с поднятым тентом

Число мест.....	8
Сухая масса, кг.....	2390
Длина, мм.....	4930
Ширина, мм.....	2050
Высота, мм.....	2280
База, мм.....	3000
Колея передняя, мм.....	1575
Колея задняя, мм.....	1634
Двигатель.....	Daimler-Benz M159, 6-цил., 2,6 л, 60 л.с.
Максимальная скорость, км/ч.....	84
Запас хода по шоссе, км.....	370

ВНИМАНИЕ!

Перед сборкой внимательно прочитайте руководство по монтажу. Каждая деталь пронумерована. Соблюдать последовательность монтажа. Необходимые рабочие инструменты: нож и напильник для зачистки деталей; резиновая лента, клейкая лента и зажимы для сушки Белья для прижимаемых склеиваемых деталей. Детали из пластика очистить в растворе мягкого моющего средства и высушить на воздухе для того, чтобы краска и переводные картинки лучше прилипали. Перед приклеиванием проверить, подходят ли детали; клей наносить экономно. Хром и краску удалить с поверхностей склеивания. Небольшие детали покрасить перед тем, как они будут удалены из рамок. Краску необходимо хорошо просушить, только после этого продолжать сборку. Каждую соответствующую переводную картинку отдельно вырезать и примерно на 20 секунд окунуть в теплую воду. На обозначенном месте картинку отделить от бумаги и прижать промокательной бумагой.

ИСПОЛЗУЕМЫЕ КРАСКИ / USED COLORS:

	Model Master		
A	1597	Черный, полуматовый	Semigloss Black
B	2094	Темно-серый, матовый	Schwarzgrau
C	1768	Белый, матовый	Flat White
D	2071	Серый, матовый	RLM Grau 02
E	1735	Дерево	Wood
F	1780	Сталь	Steel
G	1795	Черная сталь	Gun Metal

L1500A Soft Top WWII German Personnel Car

The Daimler-Benz company was designed all-wheel-drive chassis L1500A of 1,5 t capacity in the end of 1941. Most of these chassis received open bodies for transportation of 7 men (Kfz.70).

All in all there were produced about 4900 L1500A. These vehicles were extremely durable and reliable.

L1500A personnel cars were used by all German arms of service in the Soviet-German front, in North Africa, Italy, France up to the end of war.

Tactical and Technical Specifications of L1500A (Kfz.70) Soft Top

Crew, men.....	8
Empty weight, kg.....	2390
Length, mm.....	4930
Width, mm.....	2050
Height, mm.....	2280
Wheel base, mm.....	3000
Track front, mm.....	1575
Track rear, mm.....	1634
Engine.....	Daimler-Benz M159, 6 cyl., 2,6 l, 60 hp
Max. Speed, km/h.....	84
Range, km.....	370

CAUTION!

Read the instructions thoroughly prior to assembly. Each component is numbered. Adhere to specified sequence of assembly. Tools required: knife and file for removal of components from frame; rubber bond, adhesive tape and clothes pegs for clamping components together after applying adhesive. Clean plastic components in a mild detergent solution and allow to air-dry so that paint and transfers adhere better. Prior to applying adhesive, check to see whether the components fit together; apply adhesive sparingly. Remove chrome and paint from the contact surfaces. Paint small components before removing them from the frame. Allow paint to dry well, and only then continue to assemble. Cut out each transfer individually and immerse in warm water for approx. 20 seconds. Slide transfer off paper and into designated position, then press on with blotting paper.

	Model Master		
H	1790	Серебристый	Chrome Silver
J	1785	Ржавчина	Rust
K	1503	Красный, полуматовый	Red
L	2102	Желто-коричневый, мат.	Afrika Braun'42
M	2095	Темно-желтый, матовый	Panzer Dunkelgelb'43
N	2097	Зеленый, матовый Panzer	Olivgrun '43

01 СТАДИЯ СБОРКИ
ASSEMBLY STEP

03 СБОРОЧНАЯ ЕДИНИЦА
ASSEMBLY UNIT

? ПРОИЗВОЛЬНЫЙ ВЫБОР
OPTIONAL

x2 СДЕЛАТЬ ДВЕ ДЕТАЛИ
MAKE 2 PCS

A ИСПОЛЗУЕМАЯ КРАСКА
USED COLOR

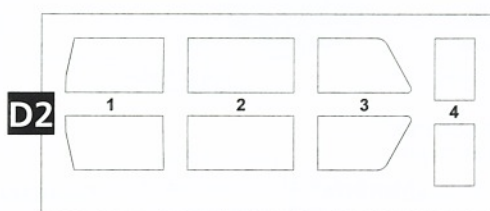
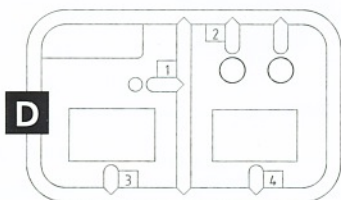
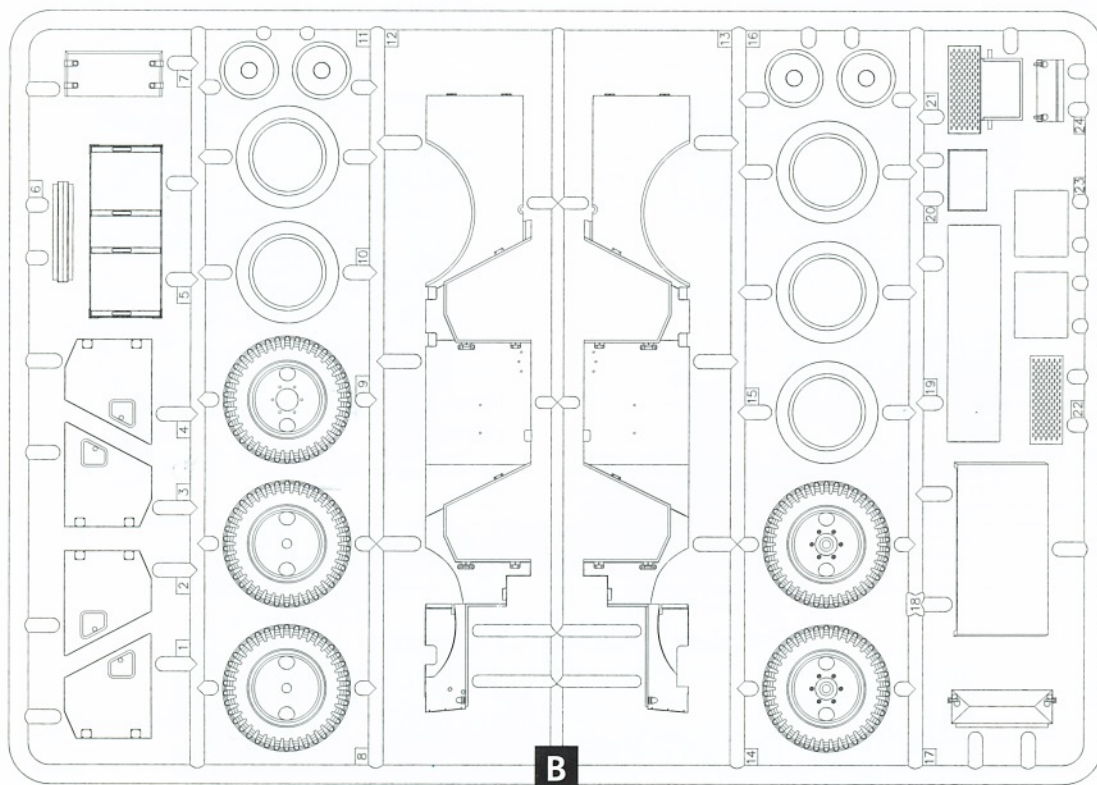
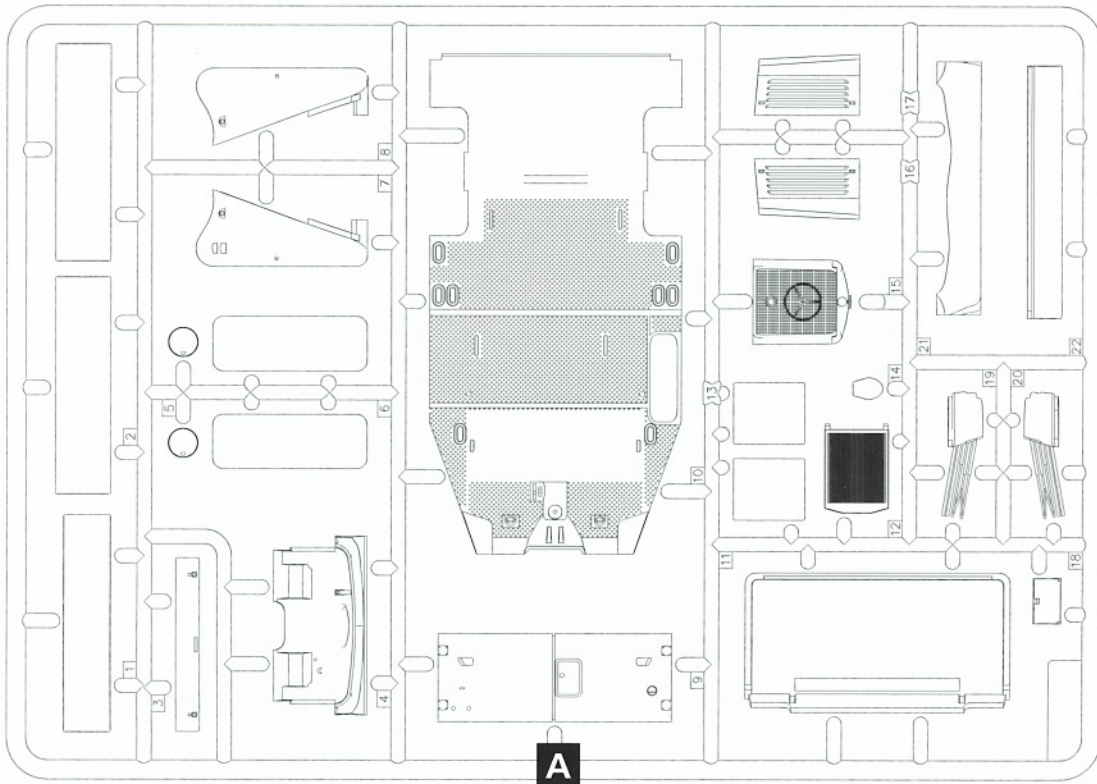

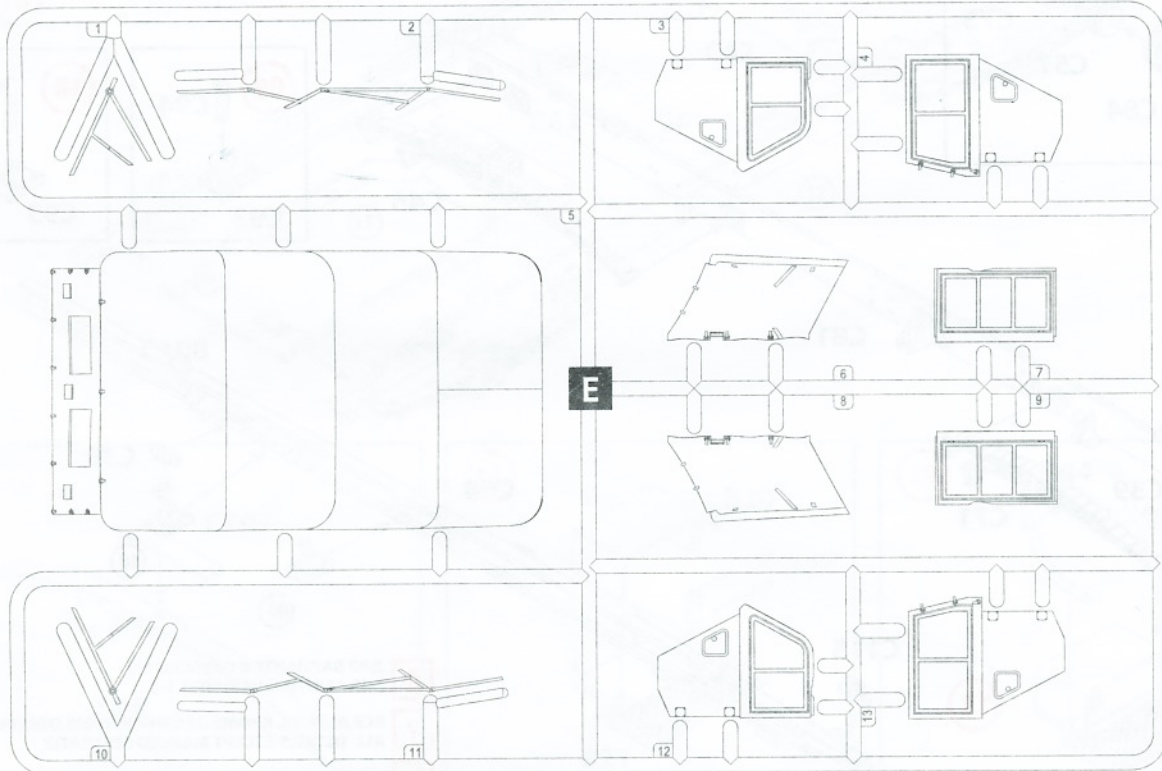
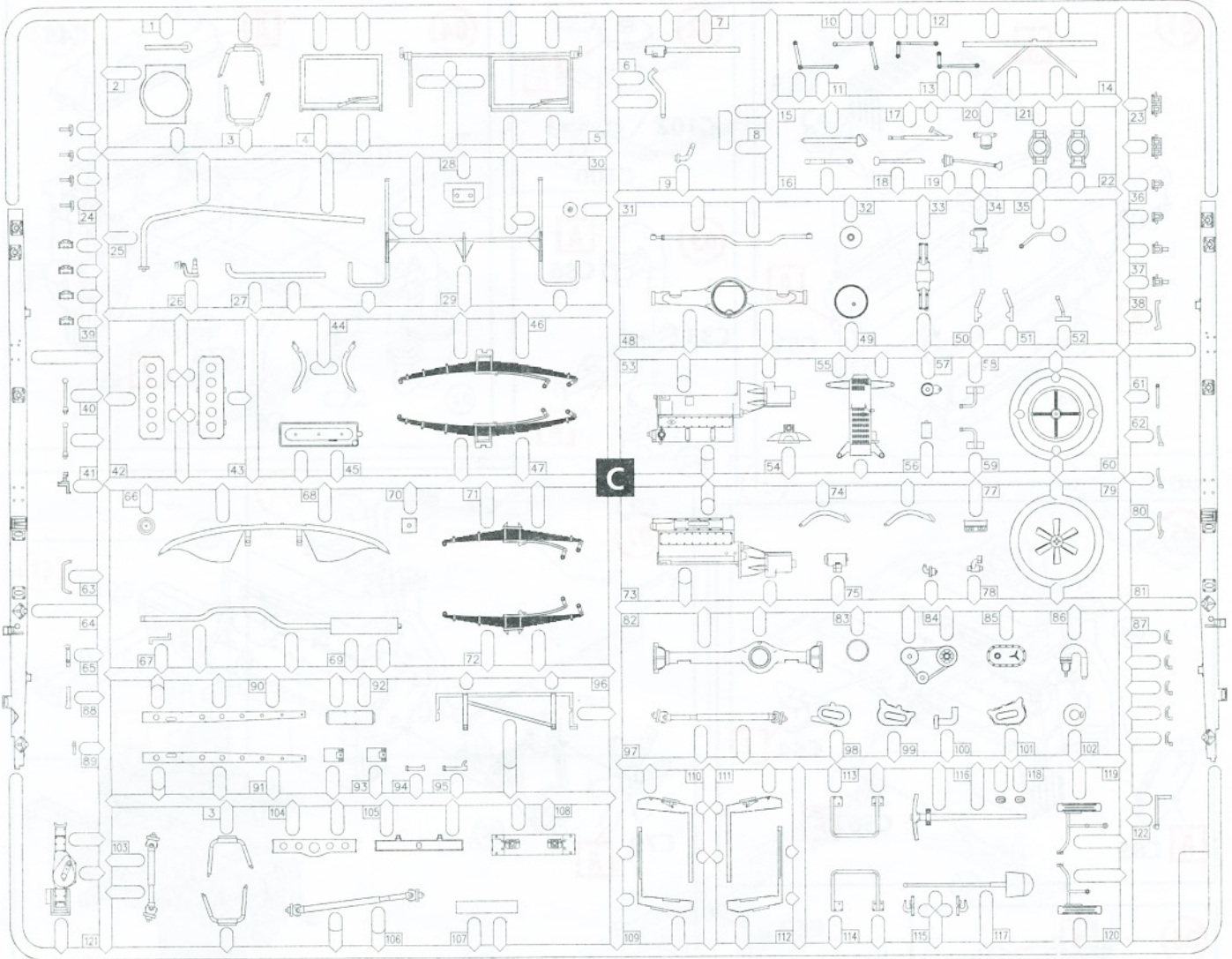

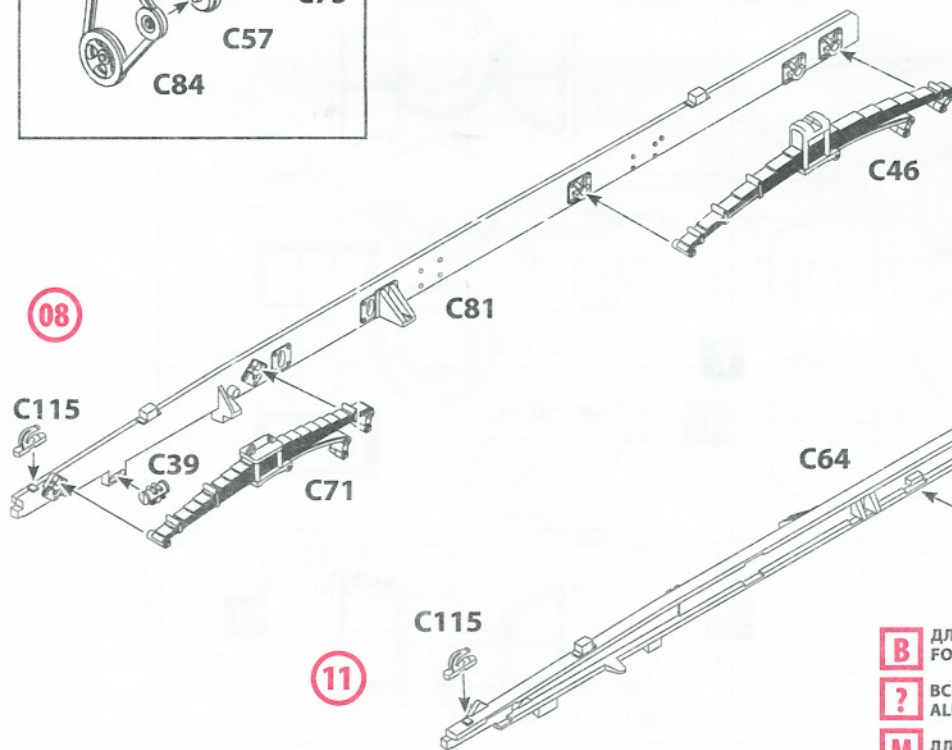
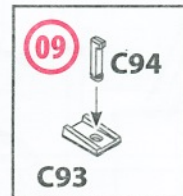
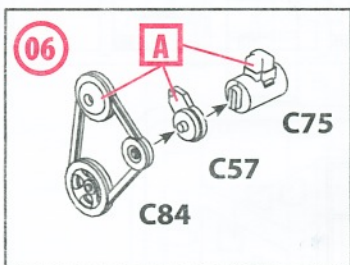
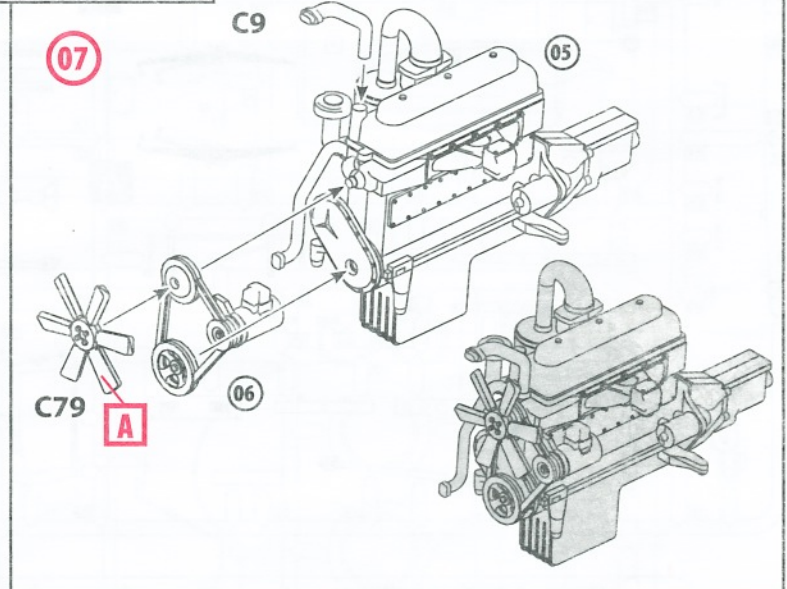
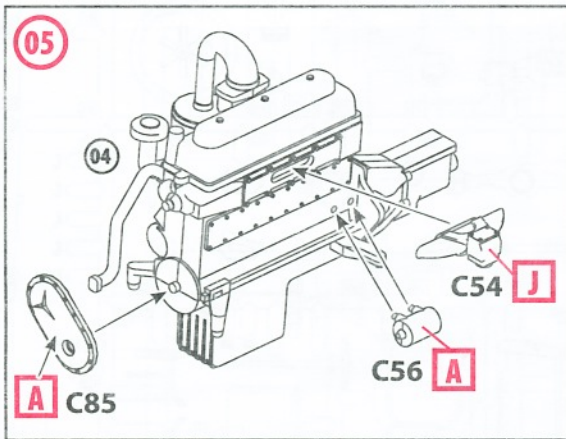
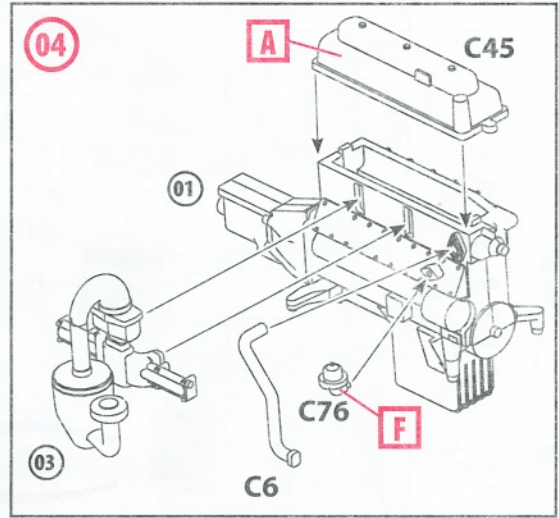
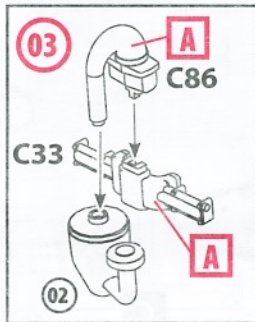
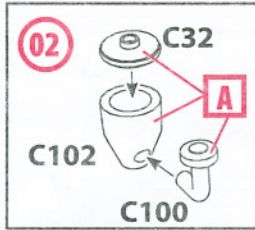
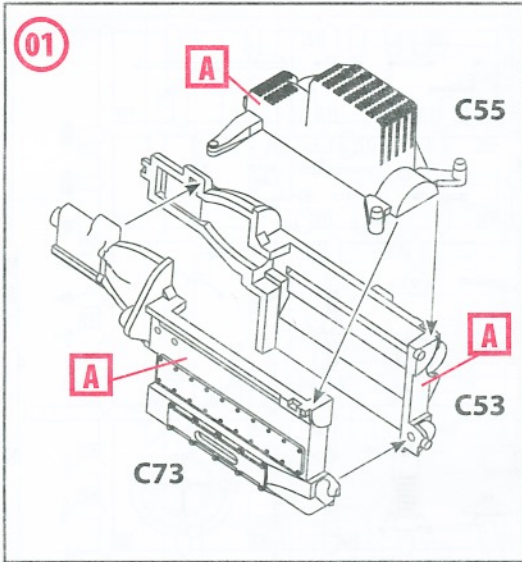

- B** ДЛЯ ВАРИАНТОВ ОКРАСКИ 1-3
FOR PAINTING VARIANTS 1-3
- ?** ВСЕ ДЕТАЛИ, КРОМЕ ОБОЗНАЧЕННЫХ ОТДЕЛЬНО
ALL DETAILS EXCEPT MARKED SEPARATELY
- M** ДЛЯ ВАРИАНТА ОКРАСКИ 4
FOR PAINTING VARIANT 4

12

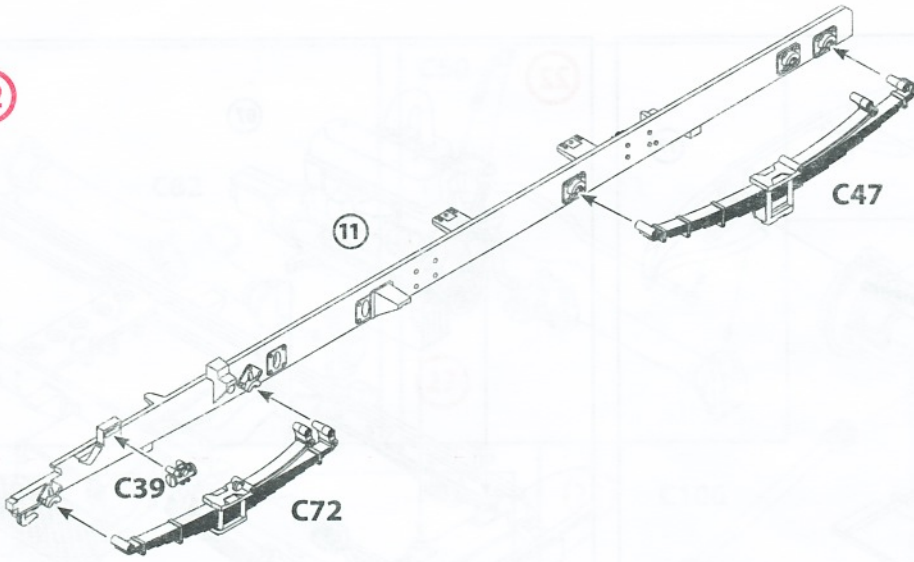

13

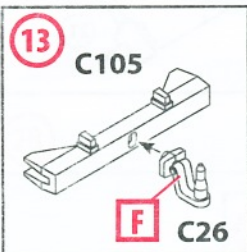

14

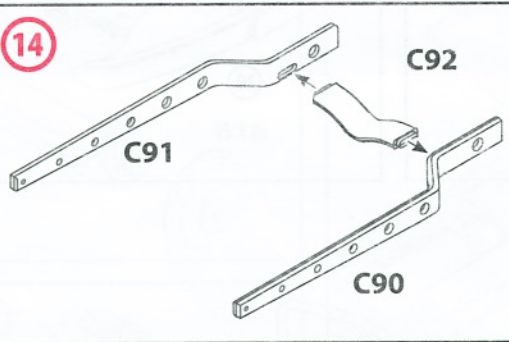

15

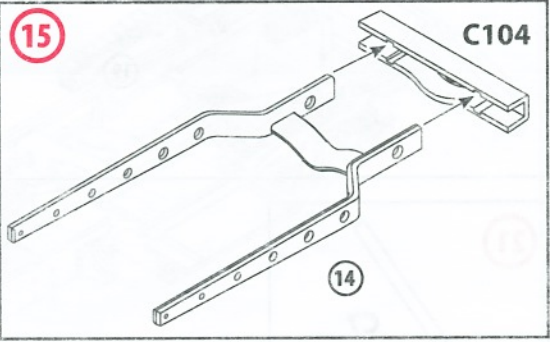

16

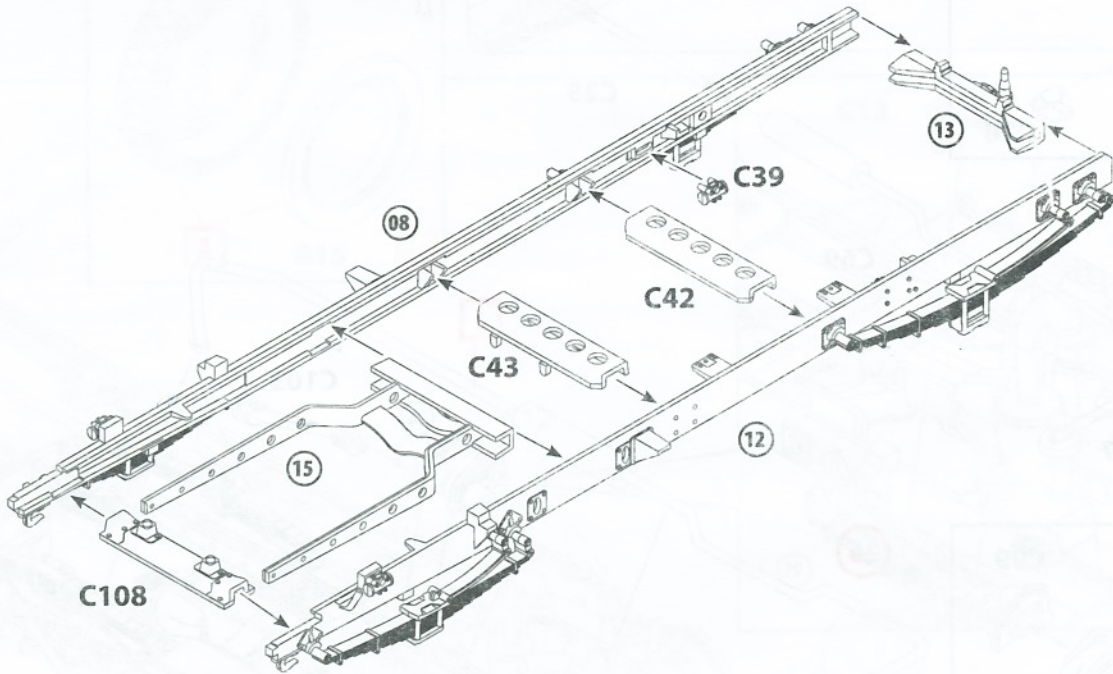

17

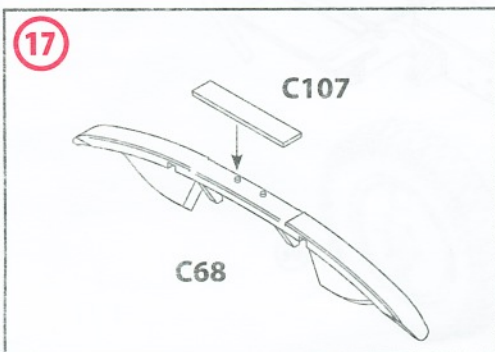

18

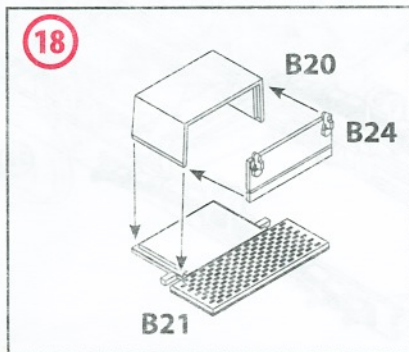

19

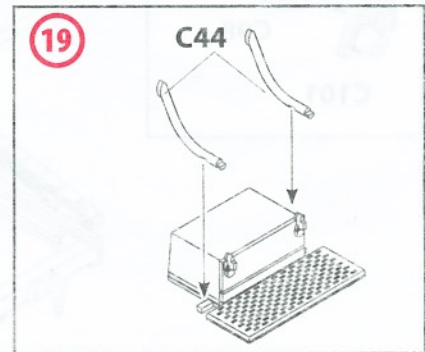

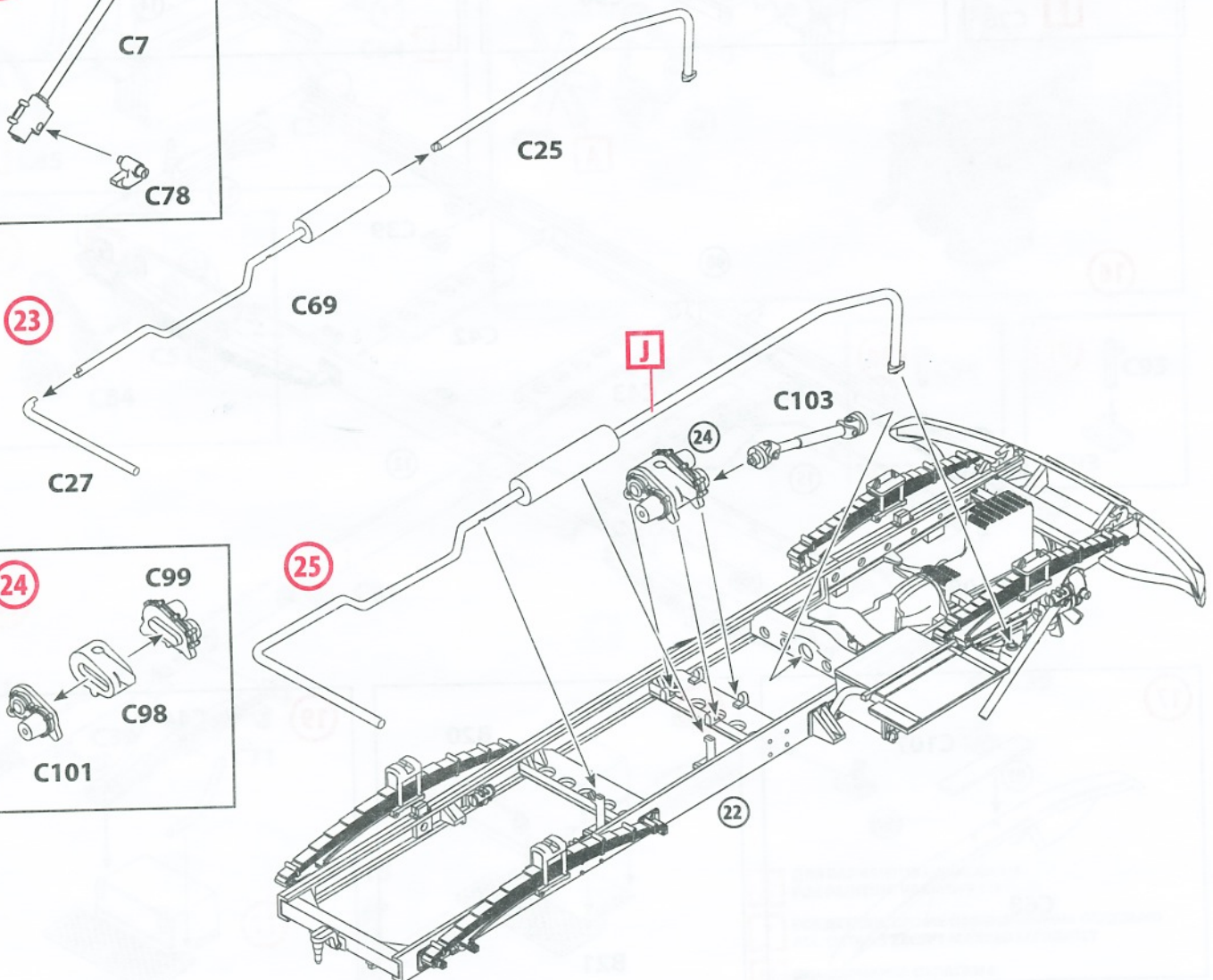
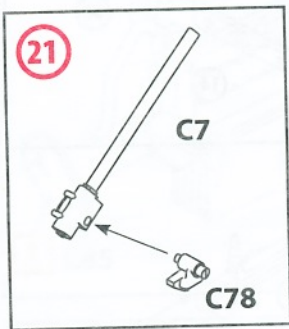
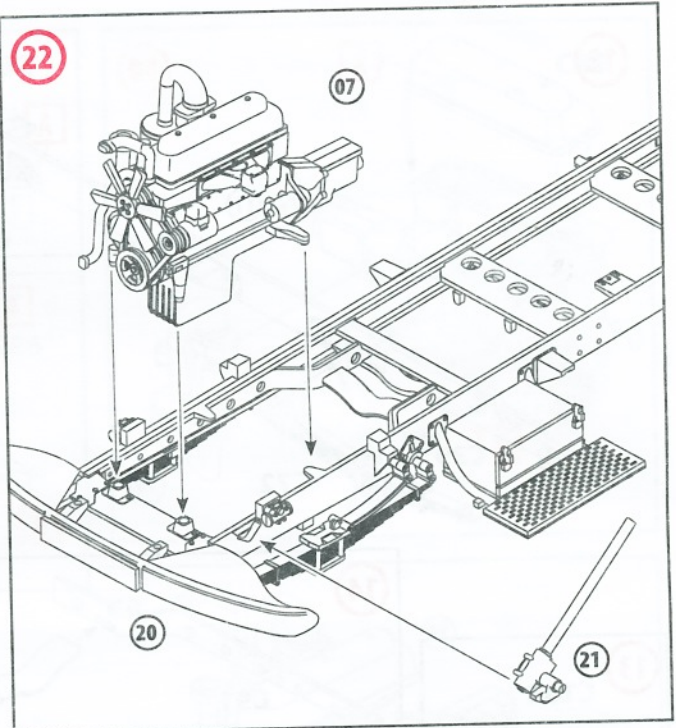
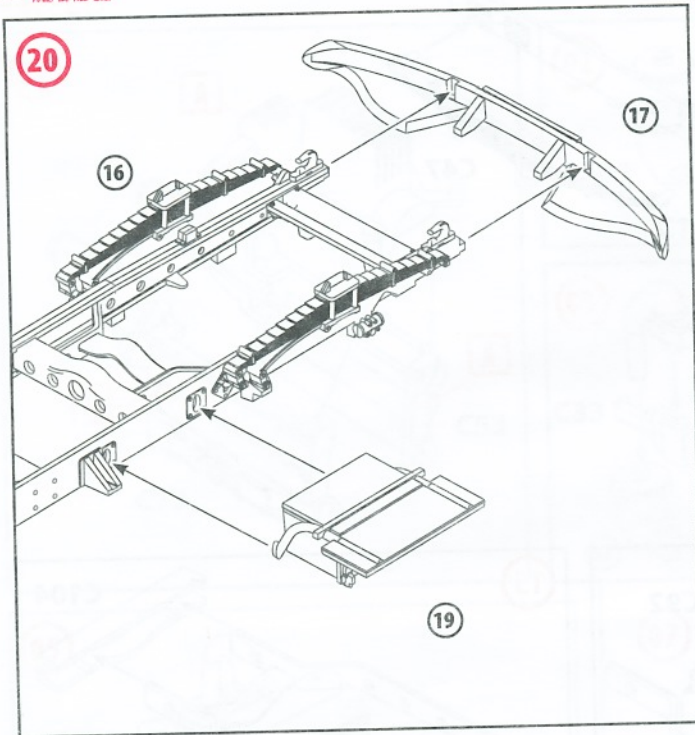

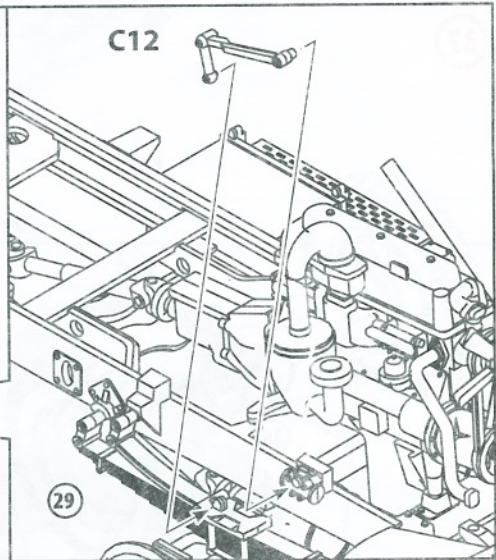
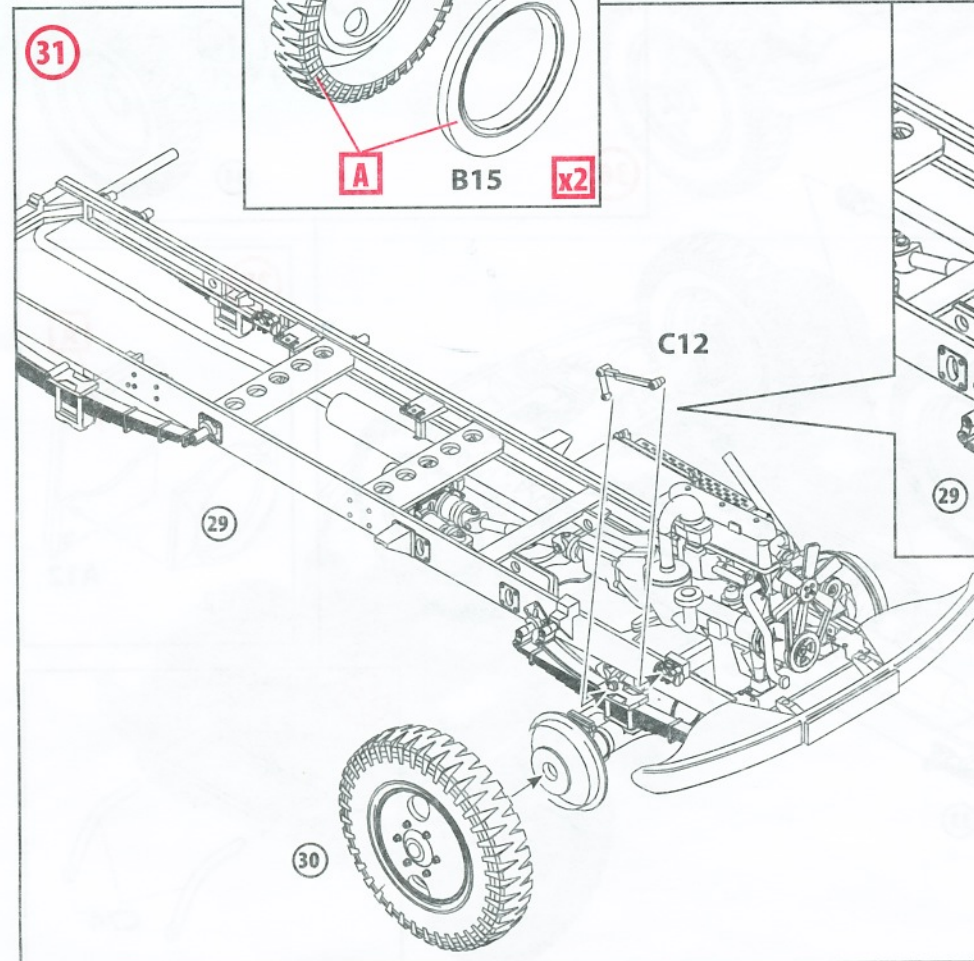
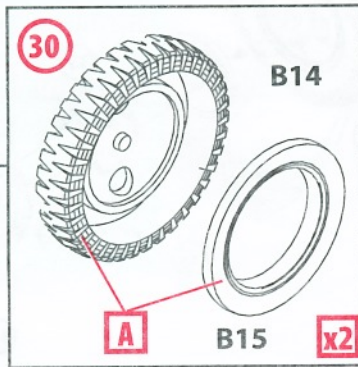
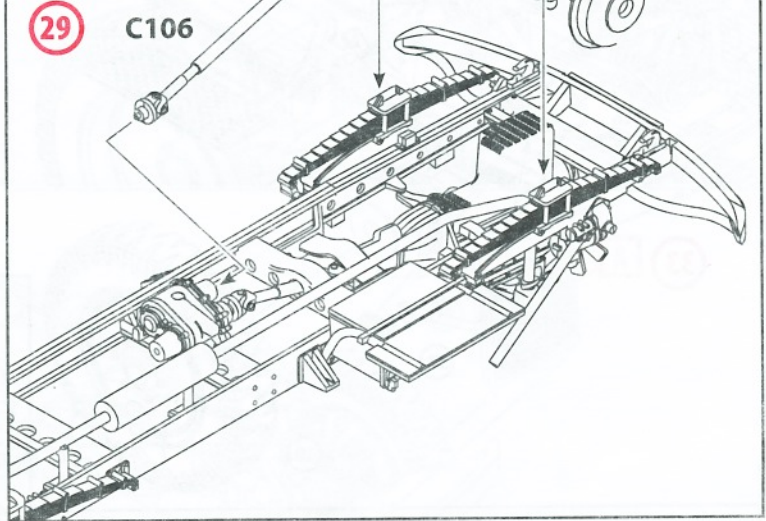
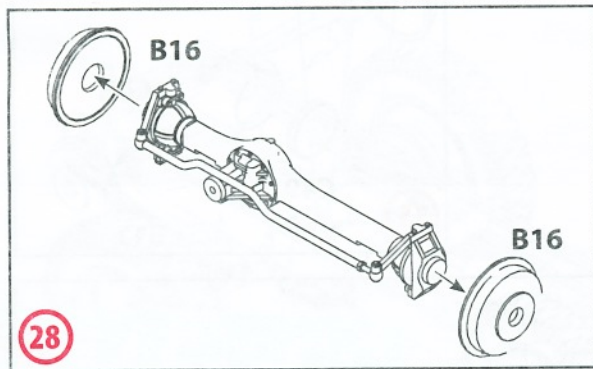
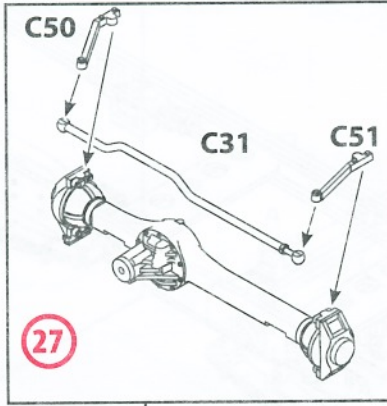
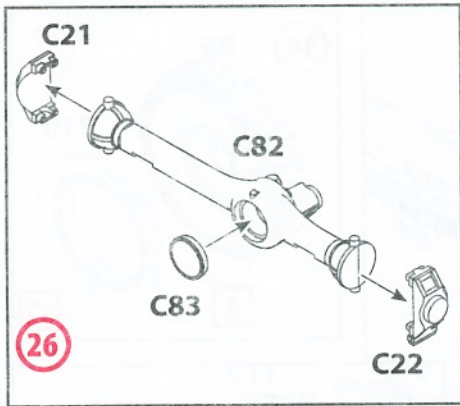

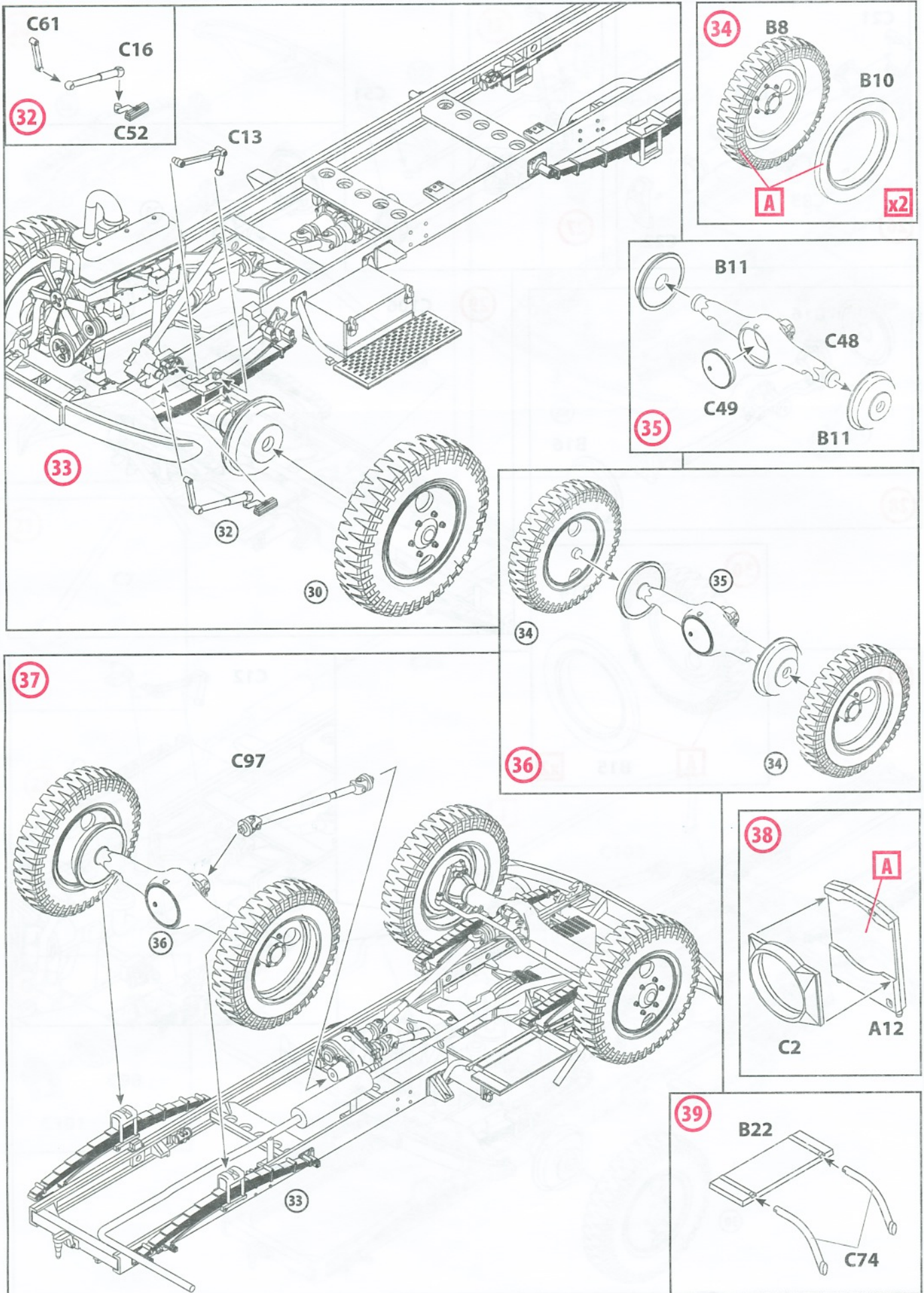

40

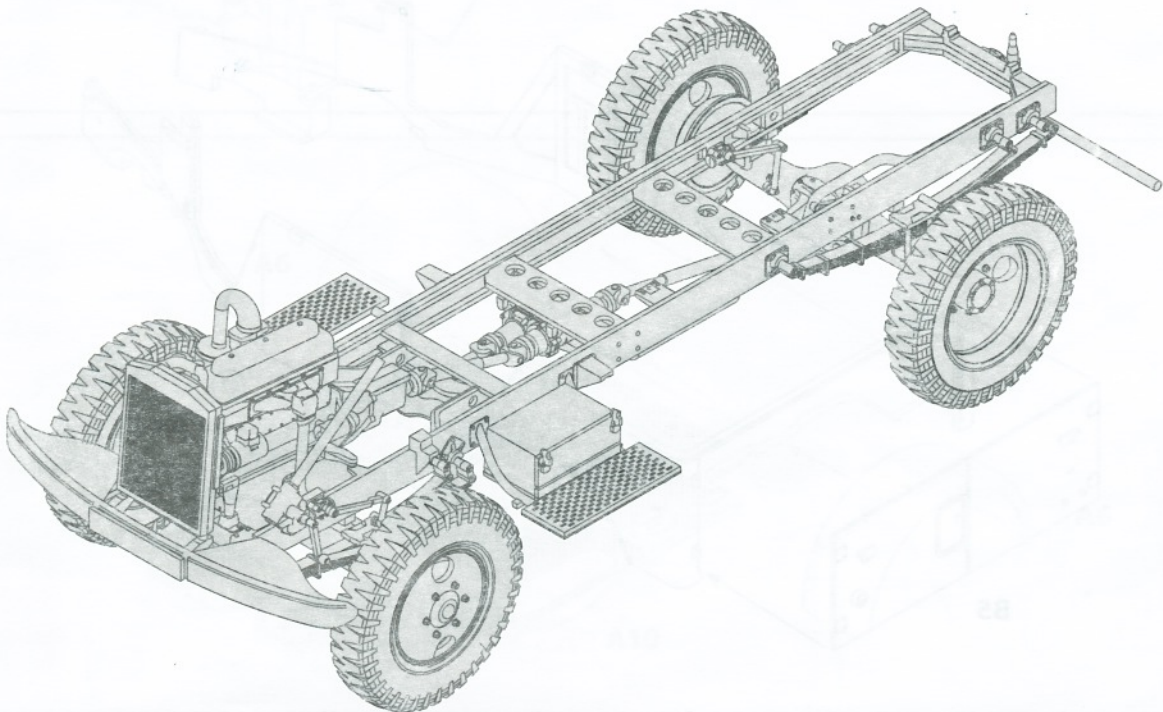
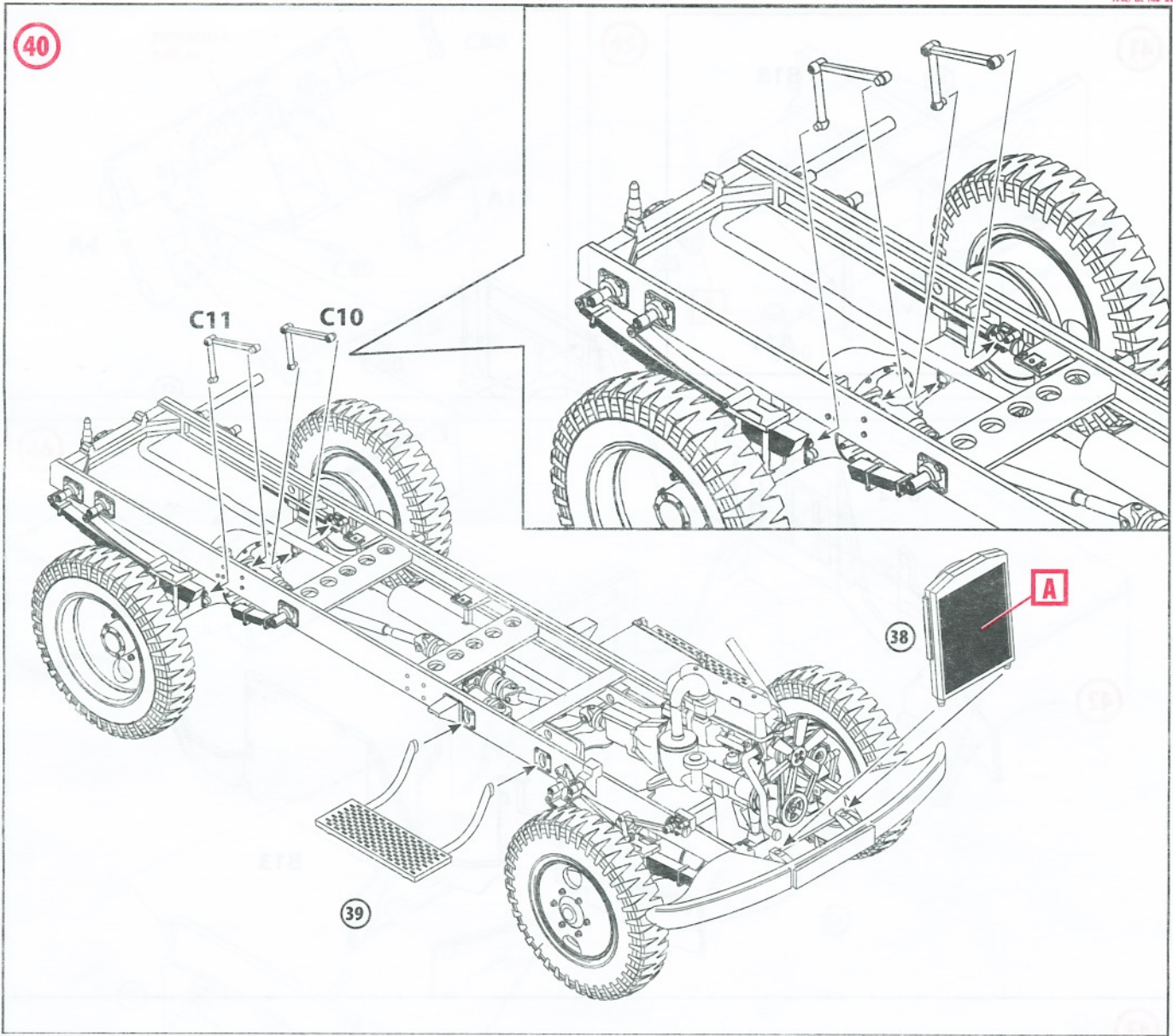

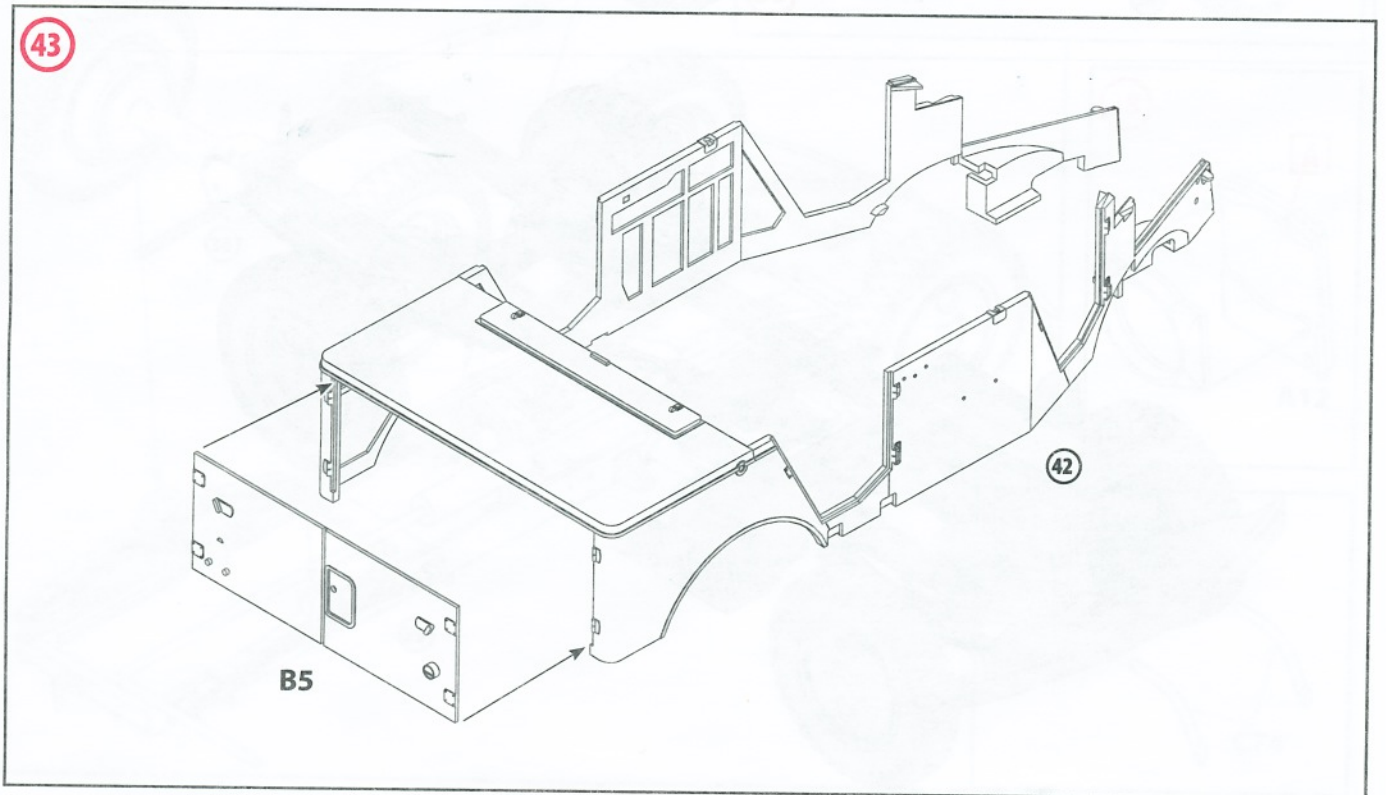
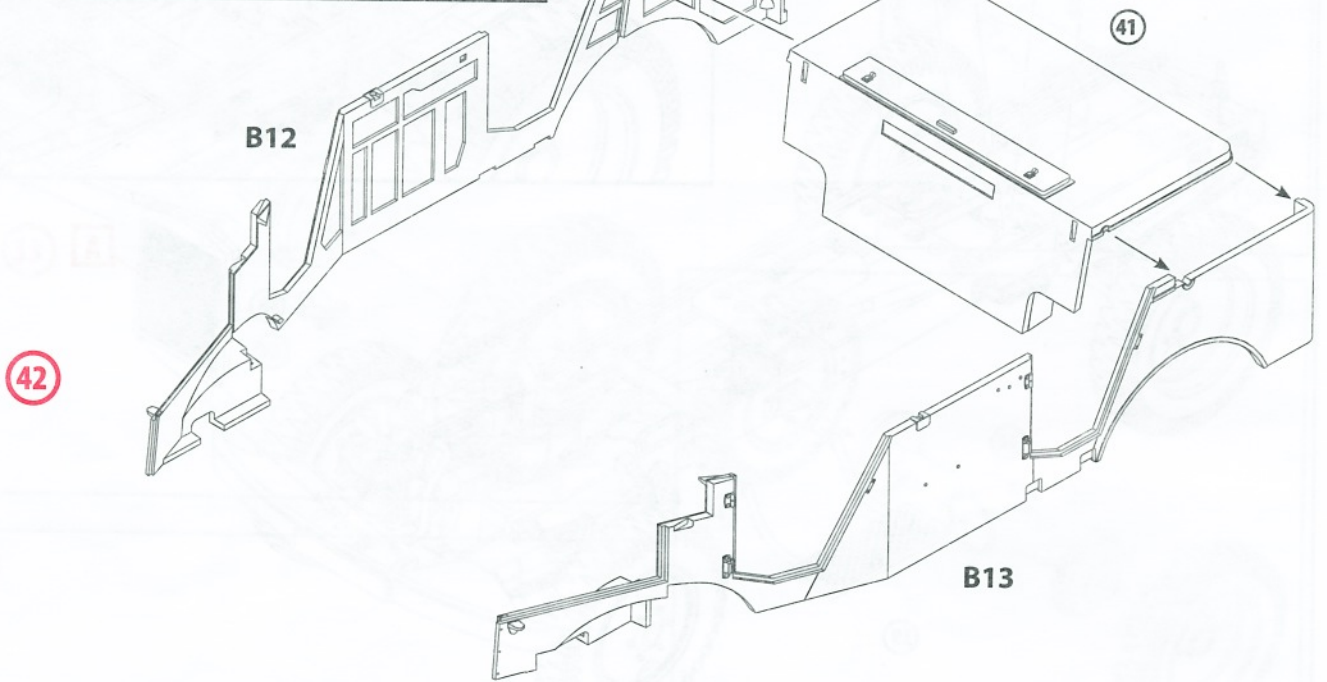
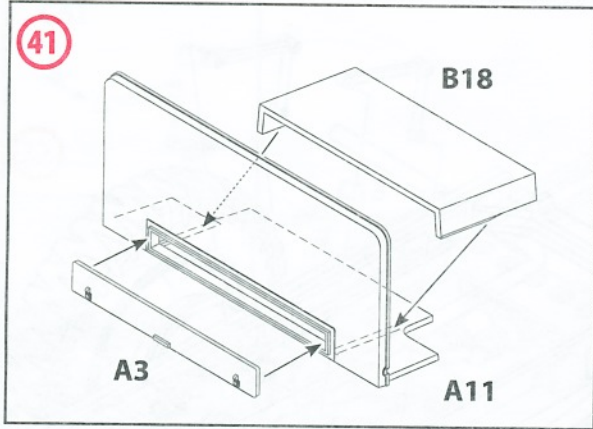

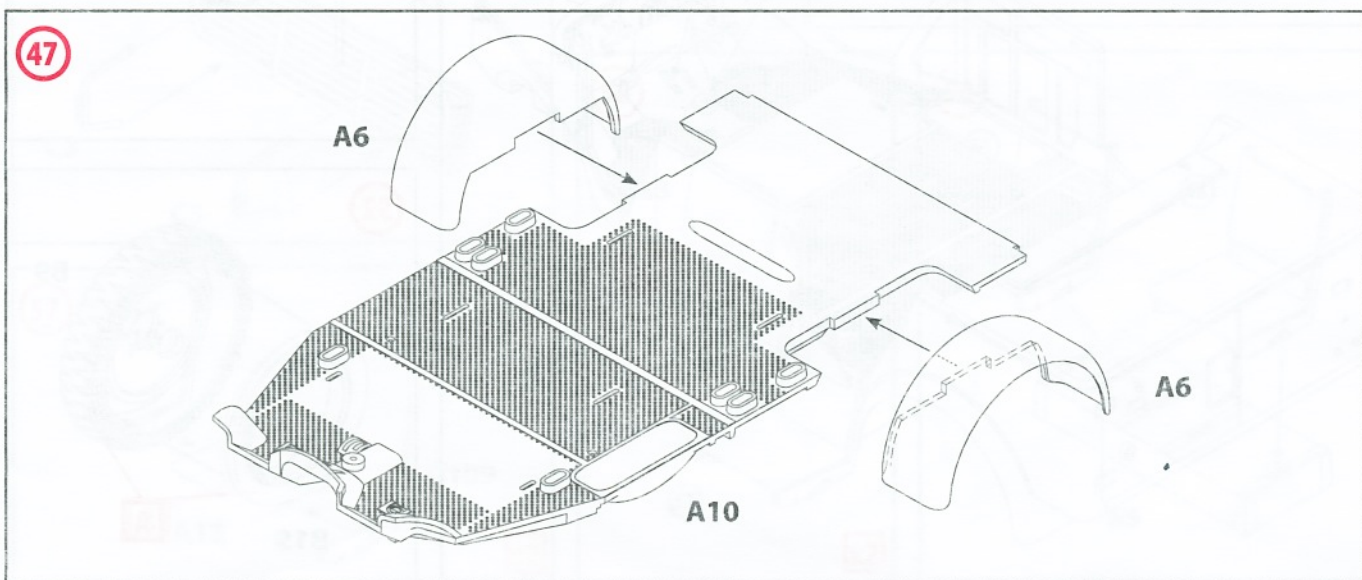
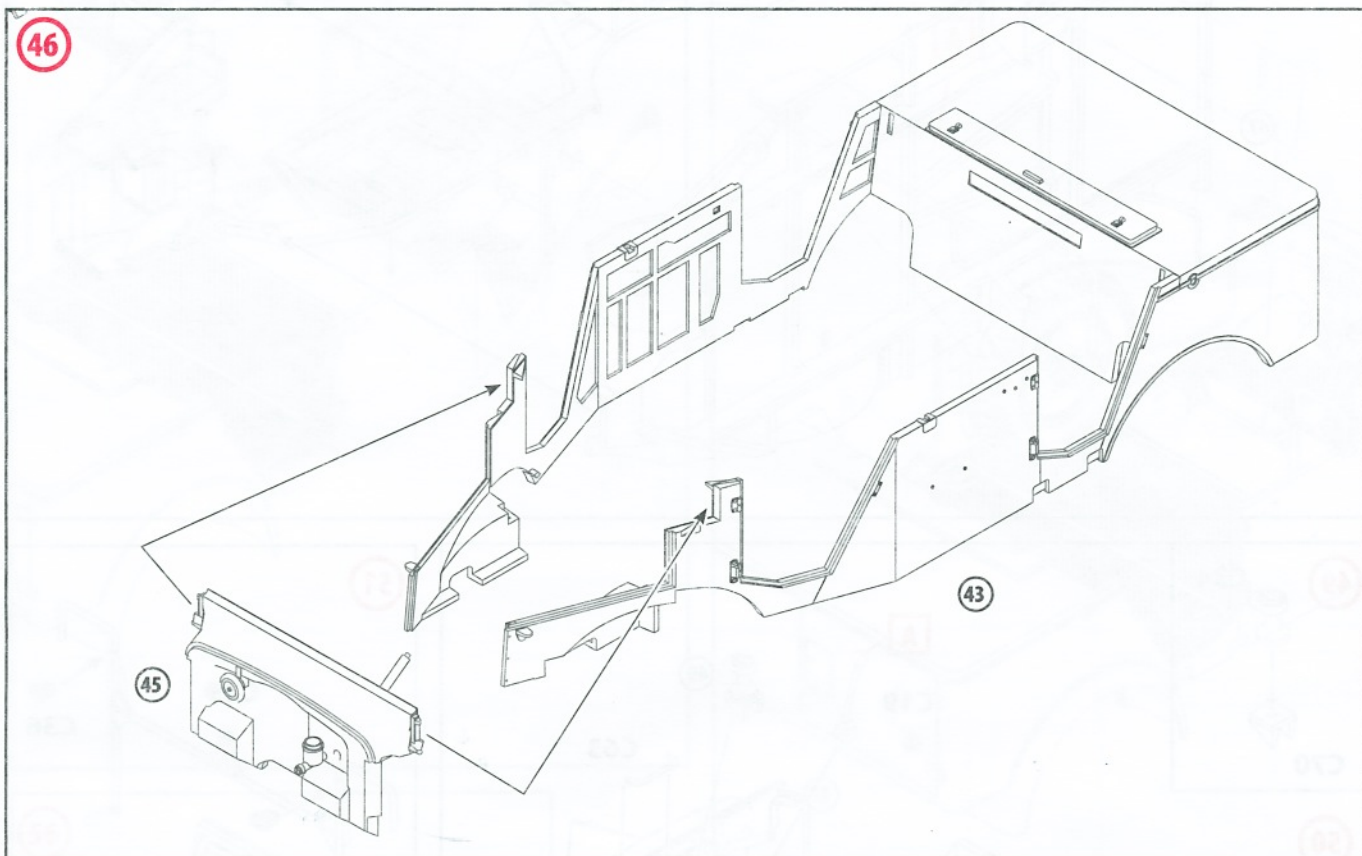
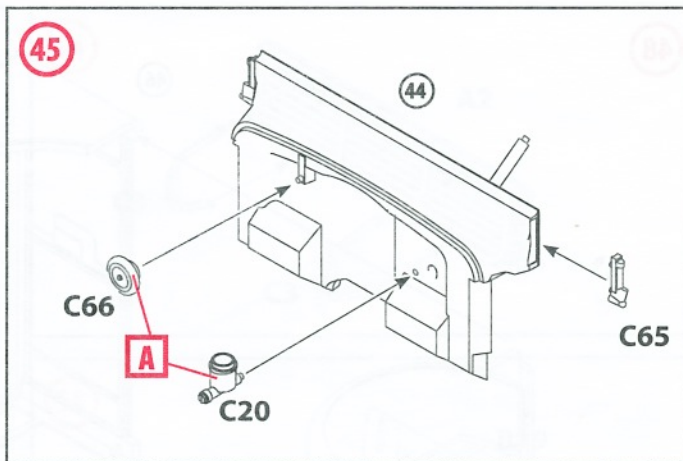
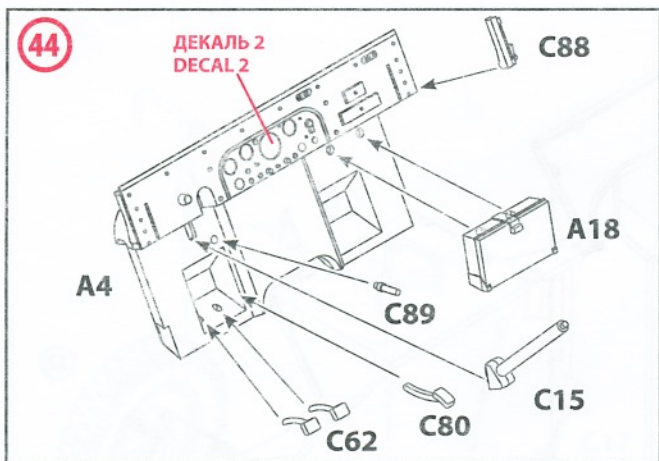

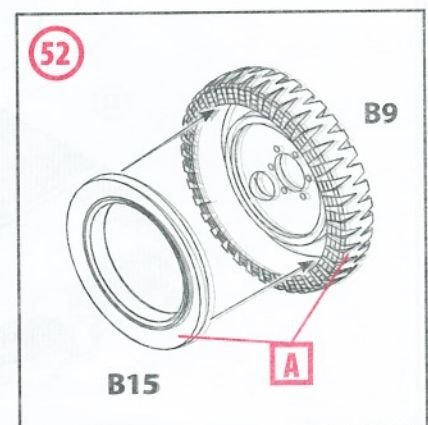
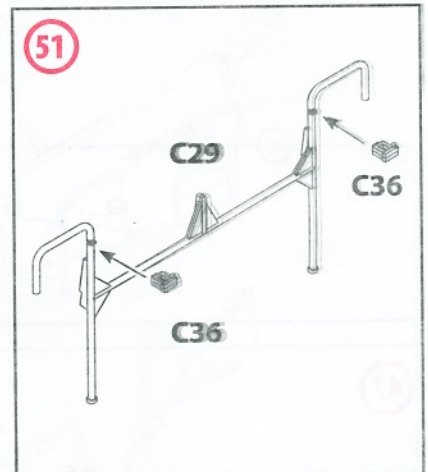
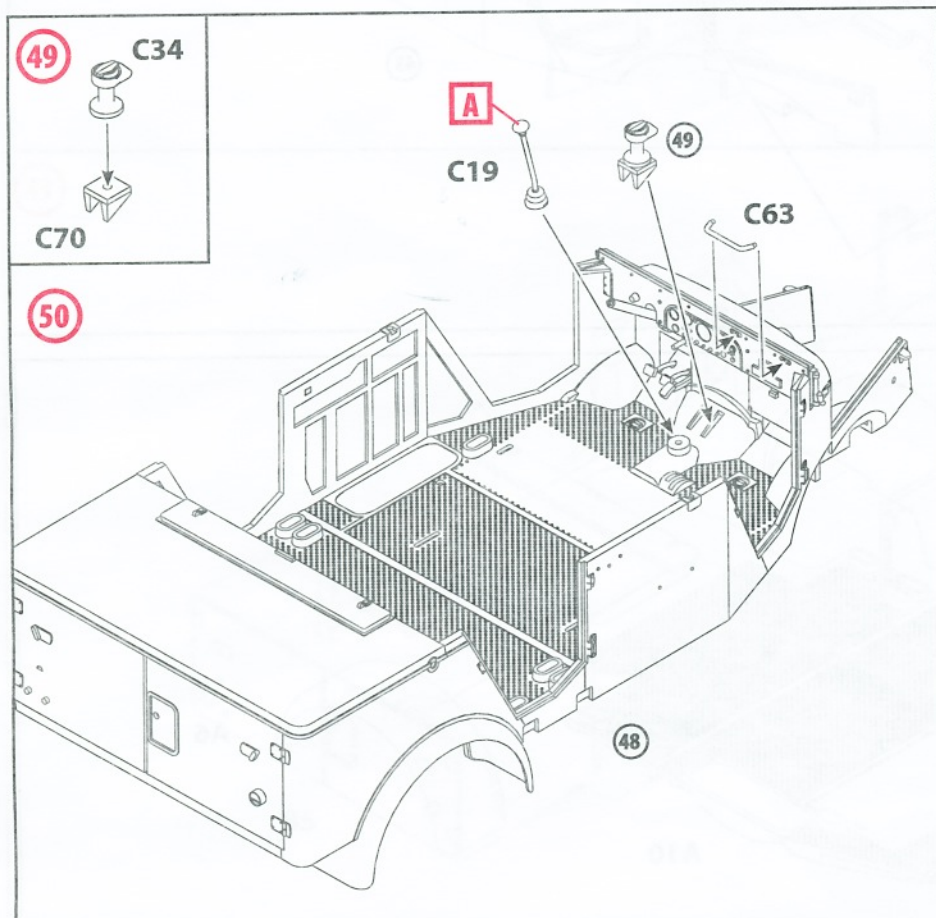
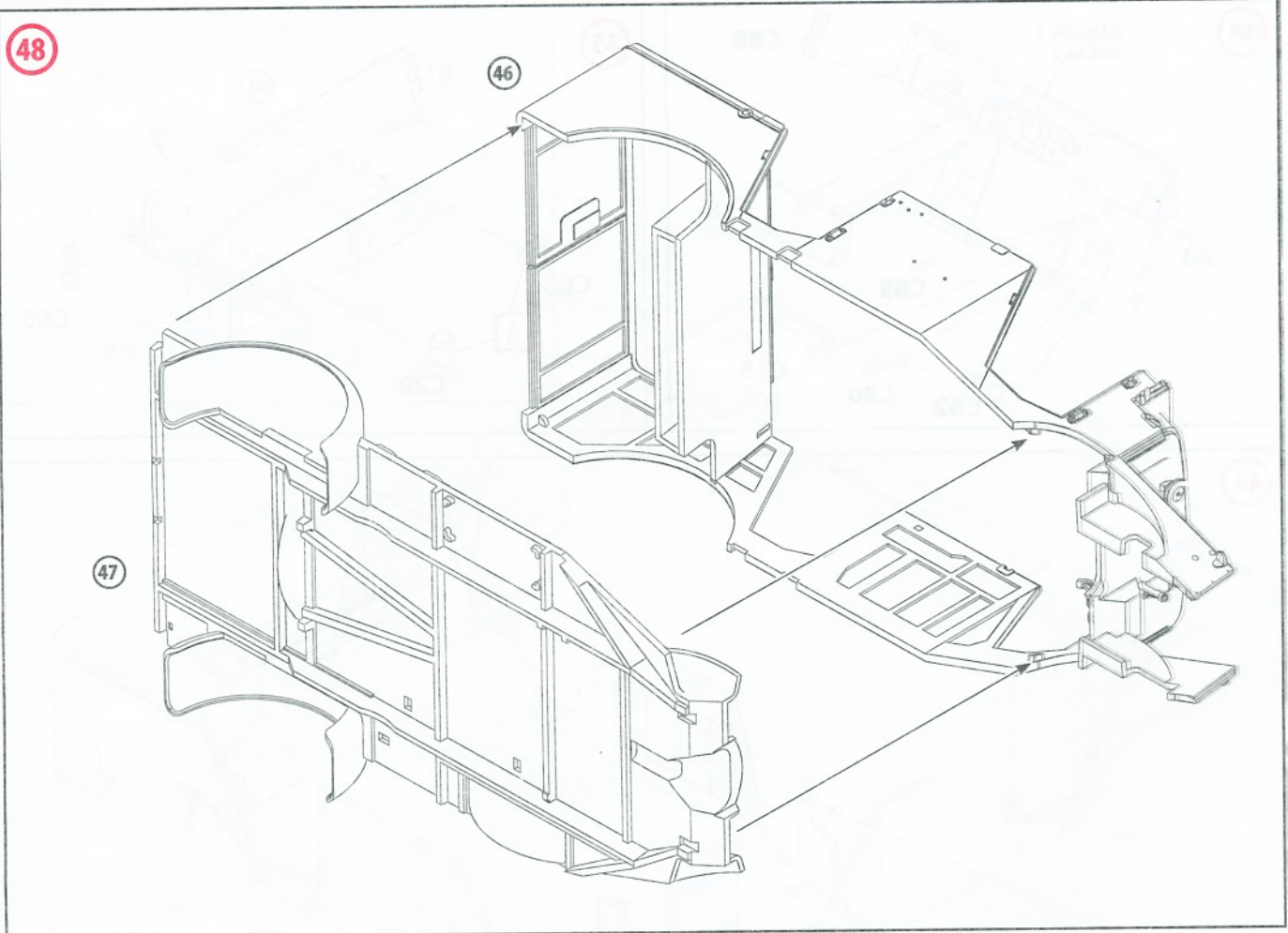

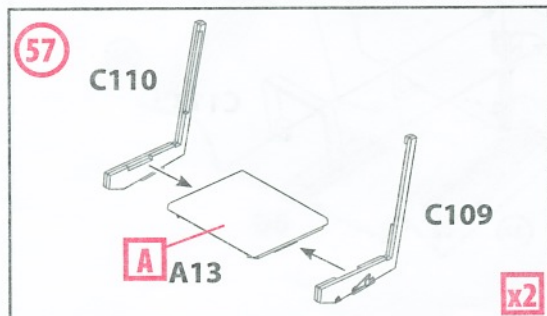
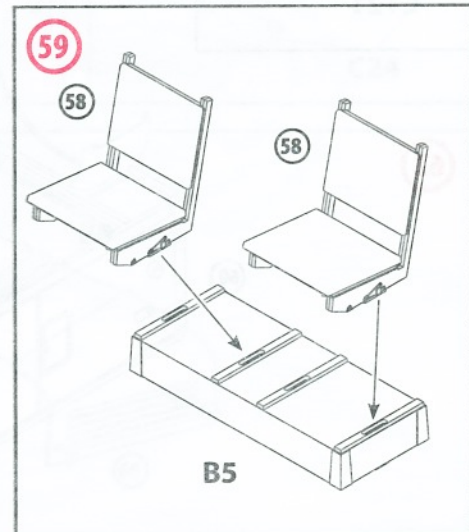
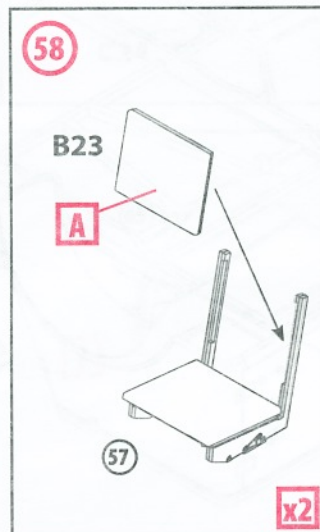
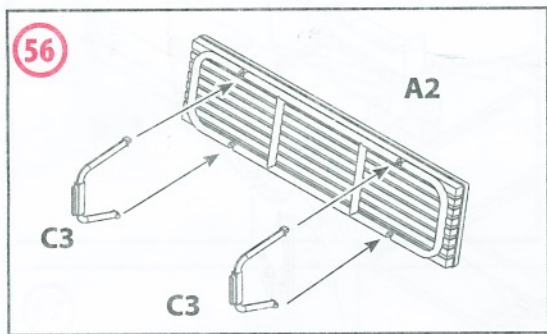
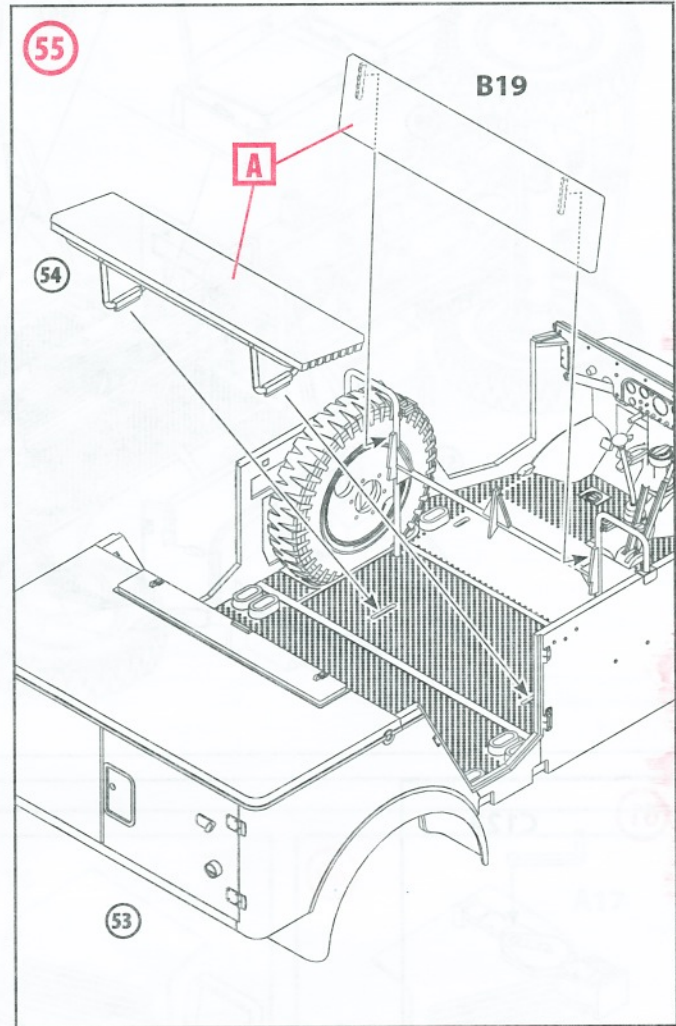
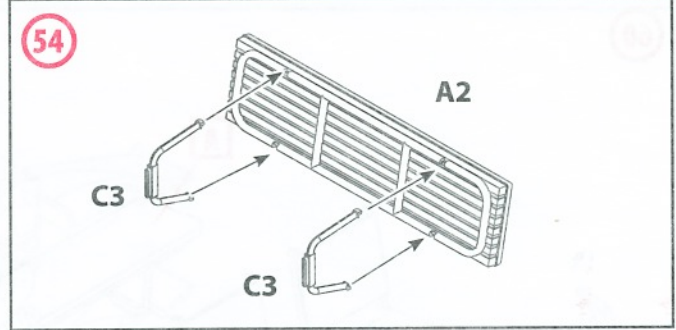
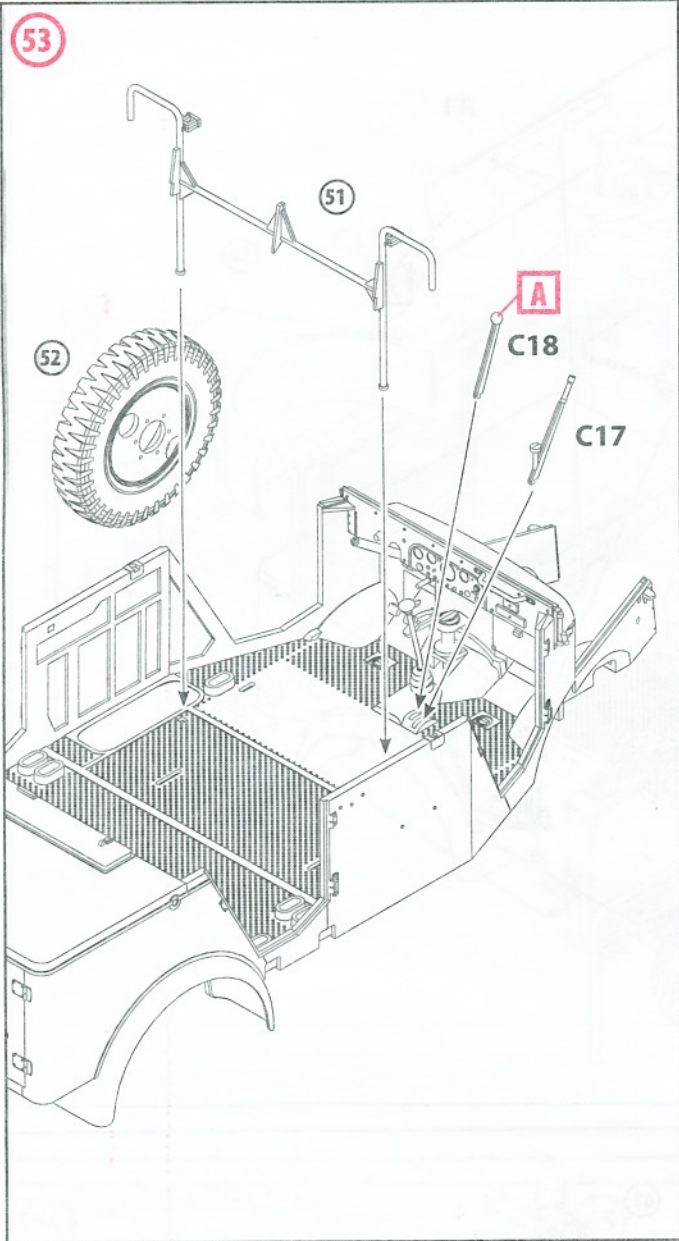

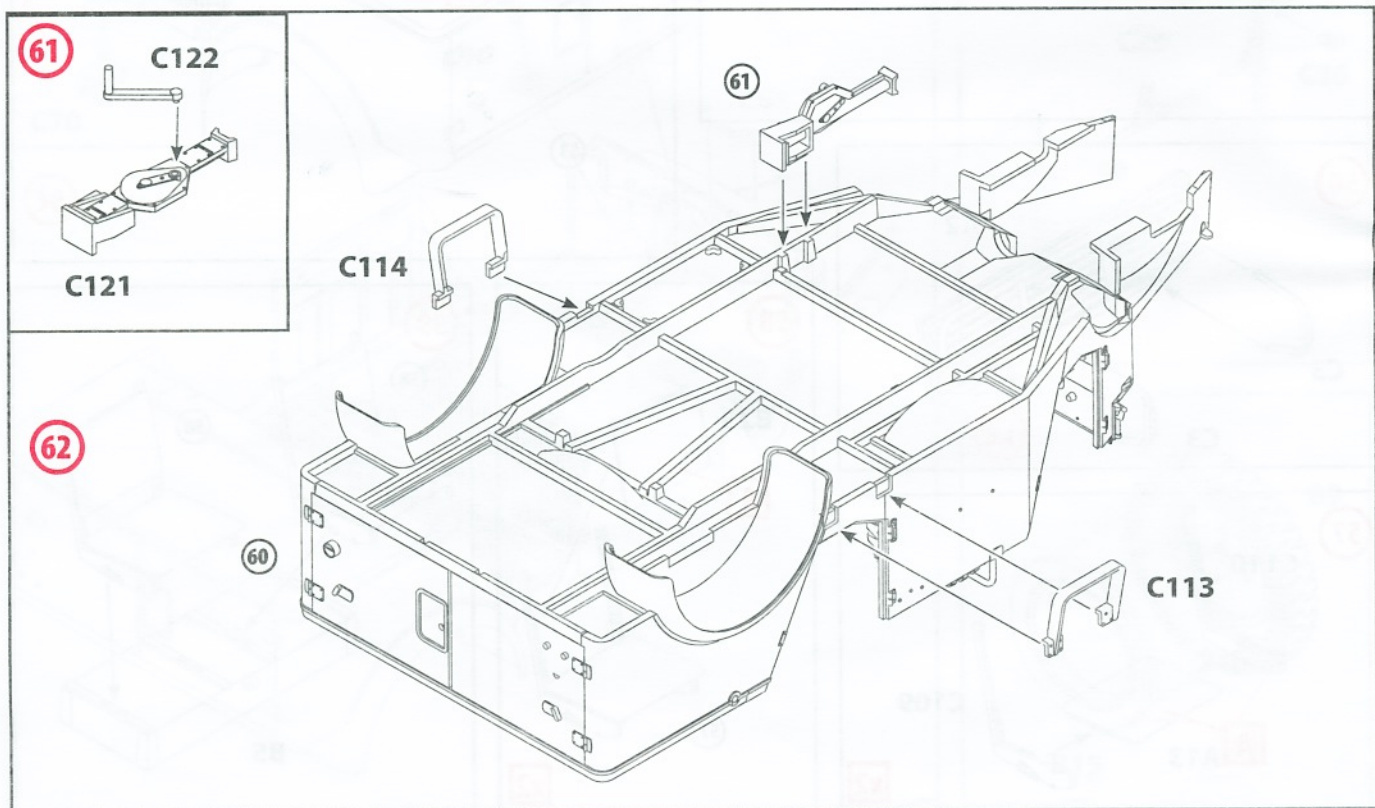
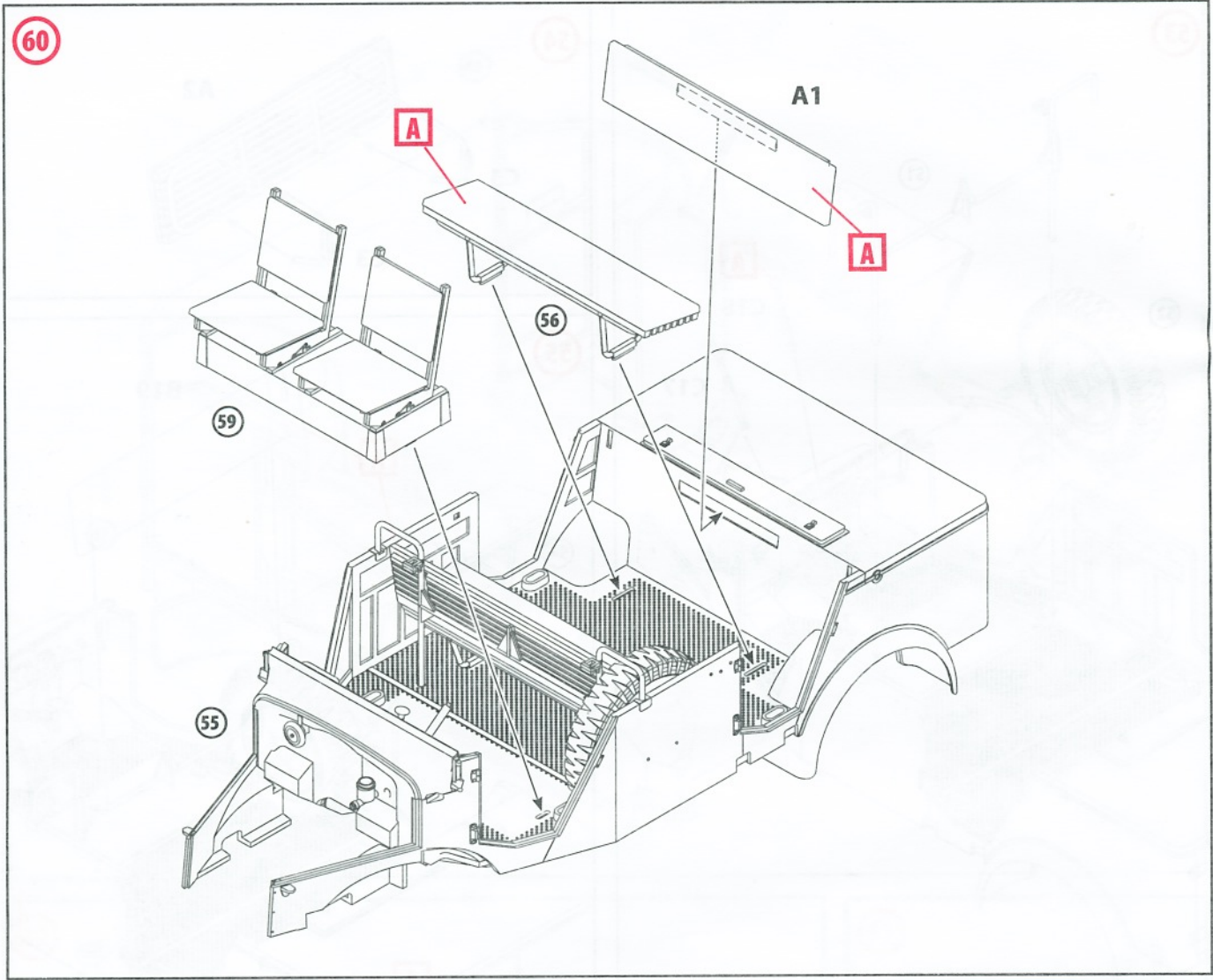

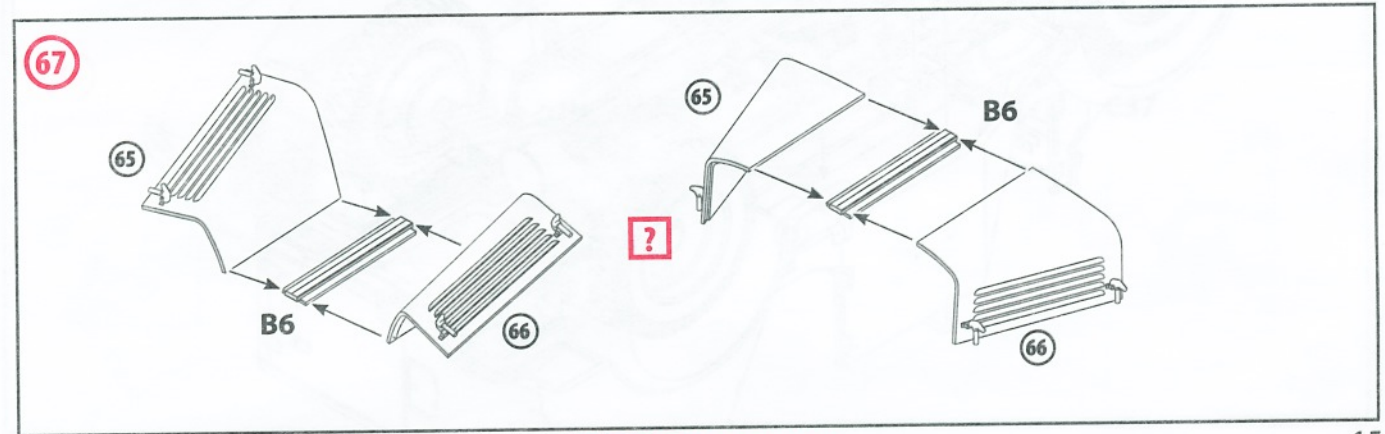
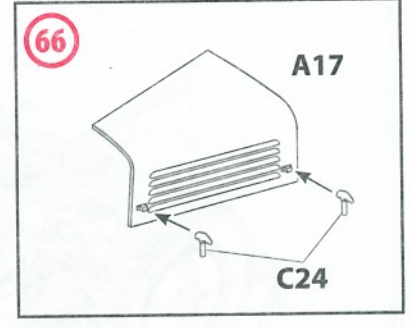
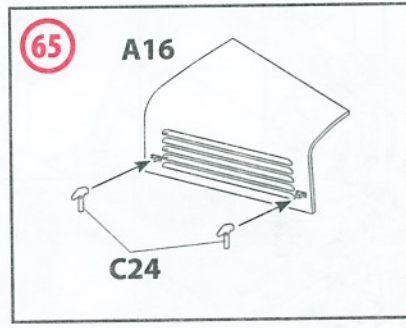
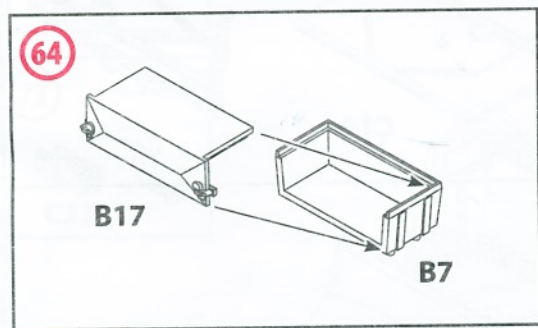
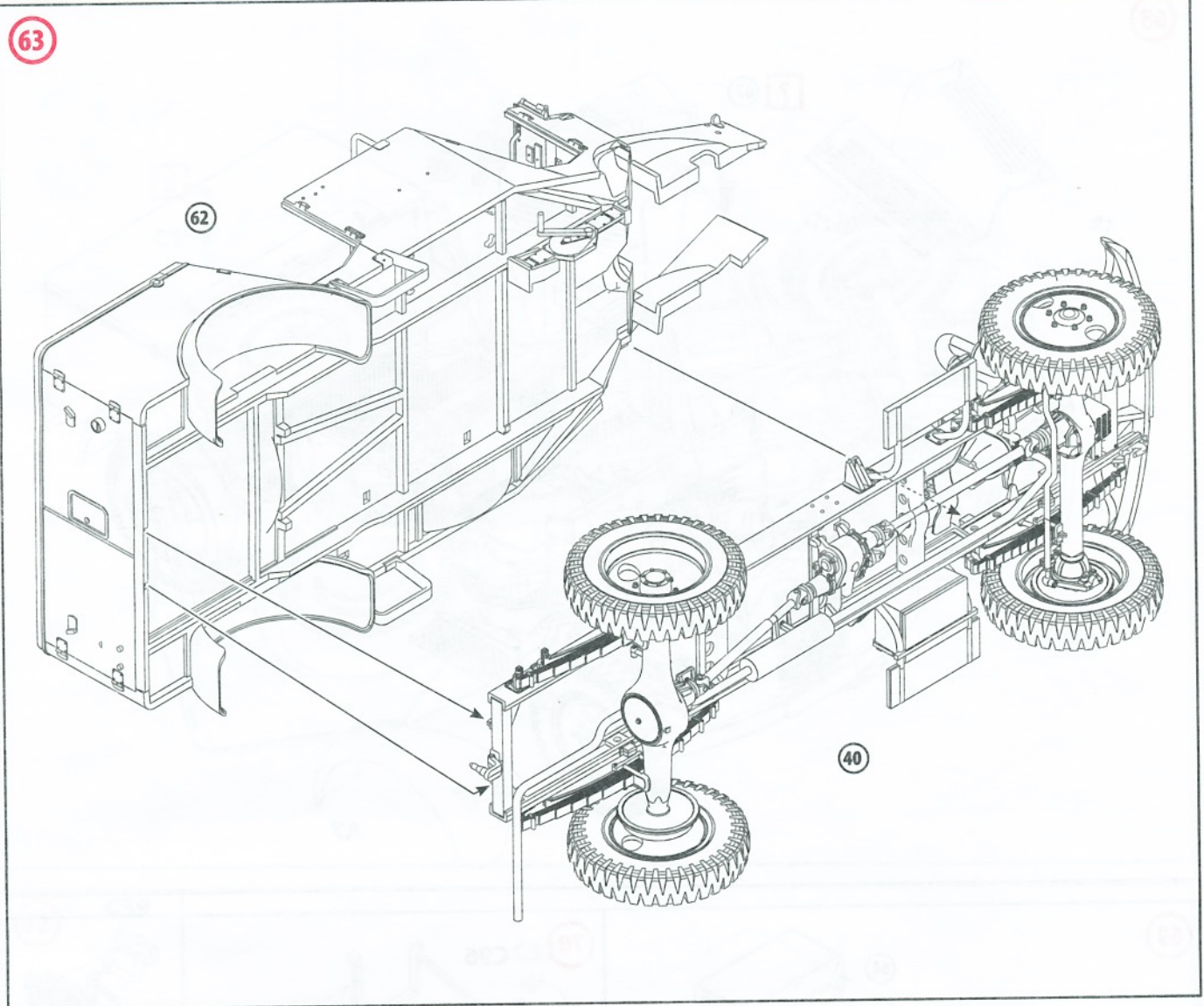

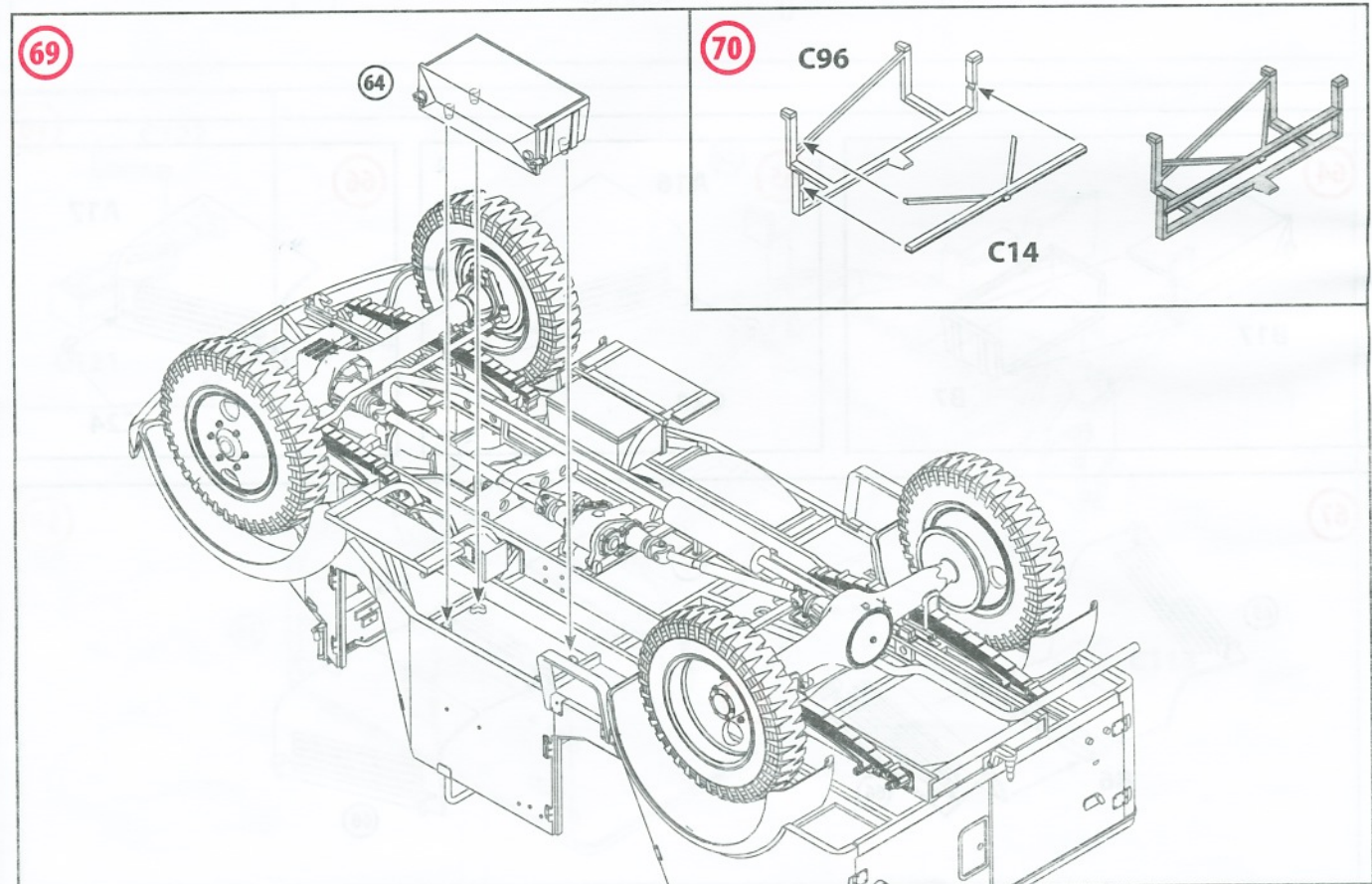
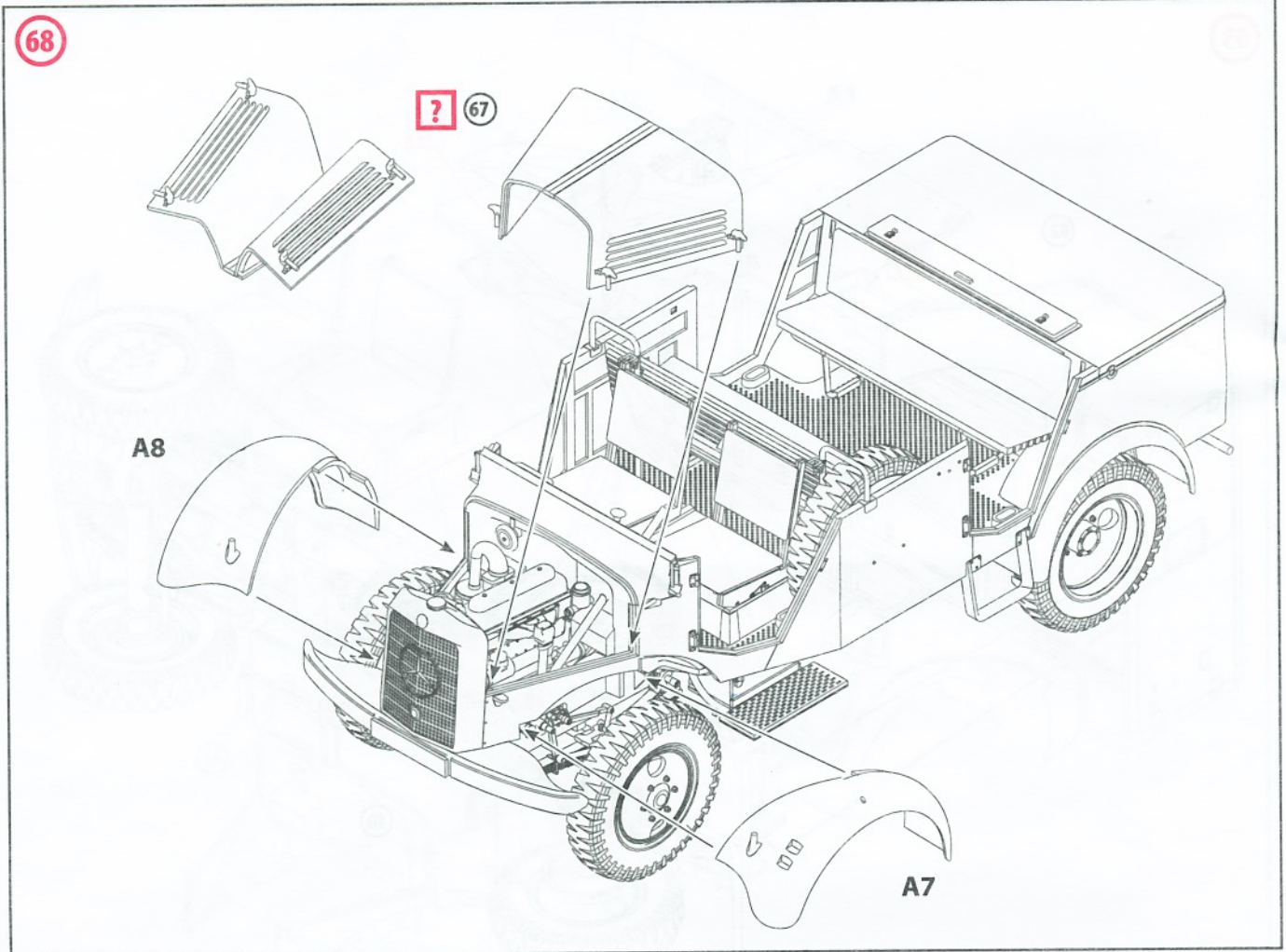

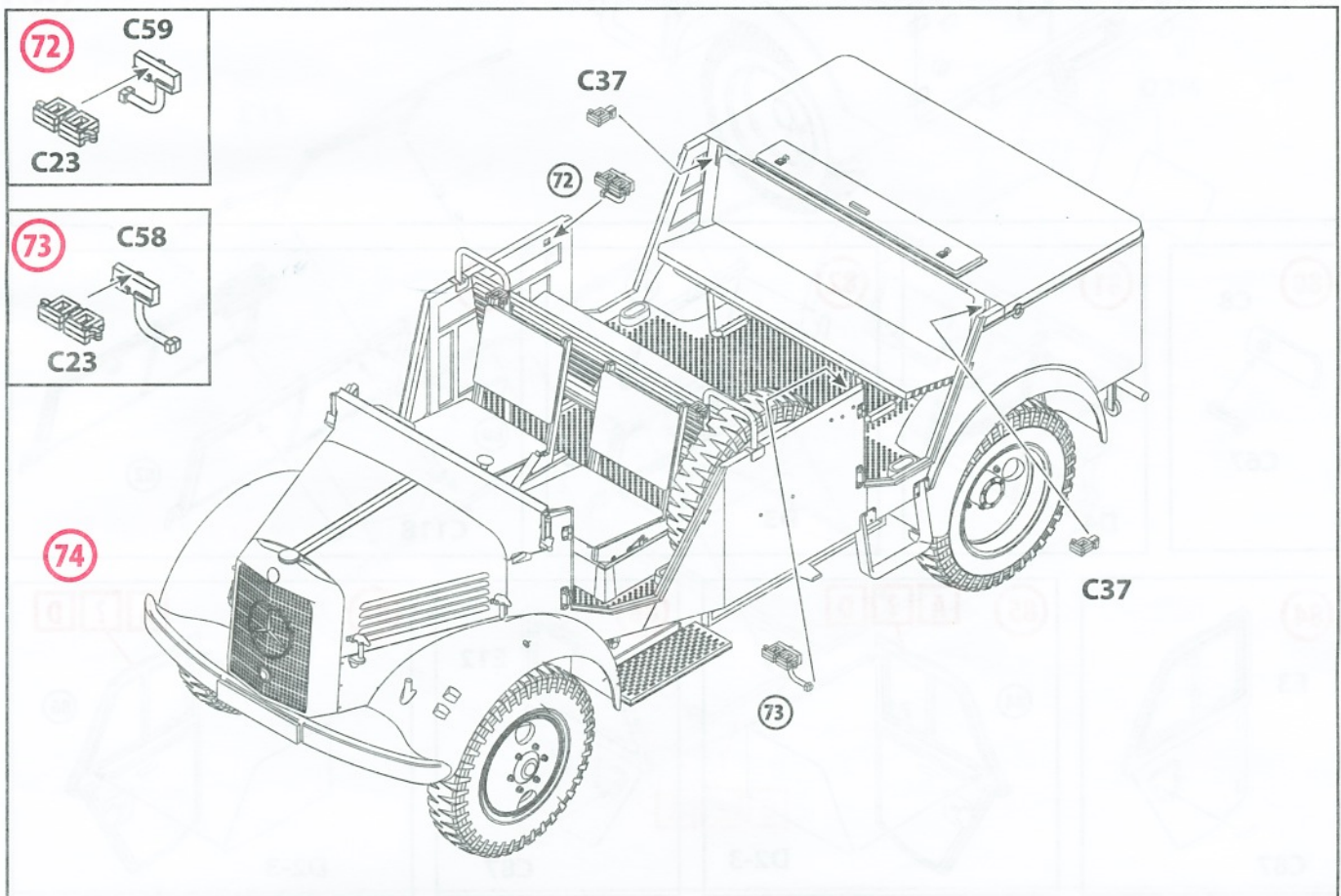
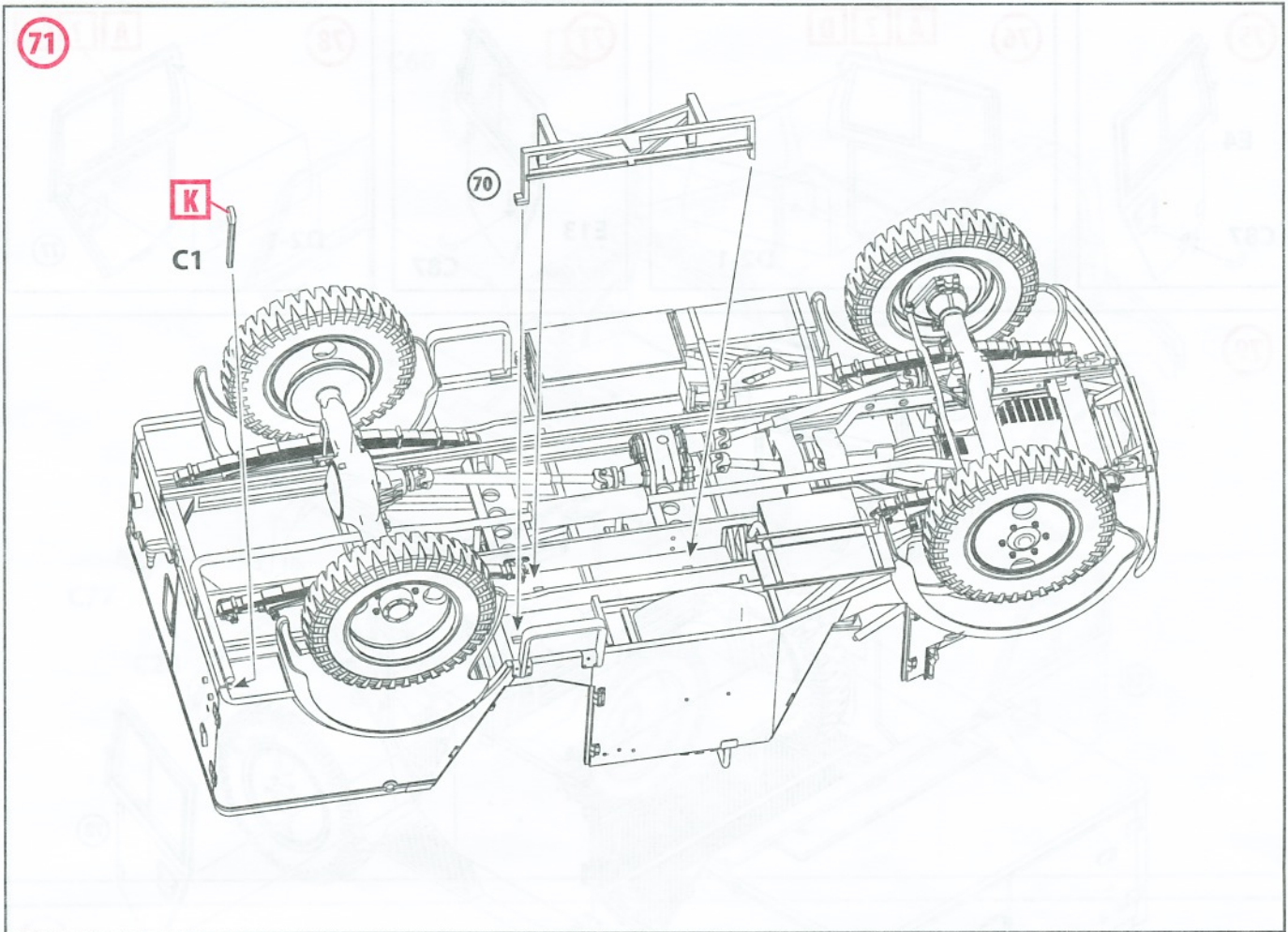

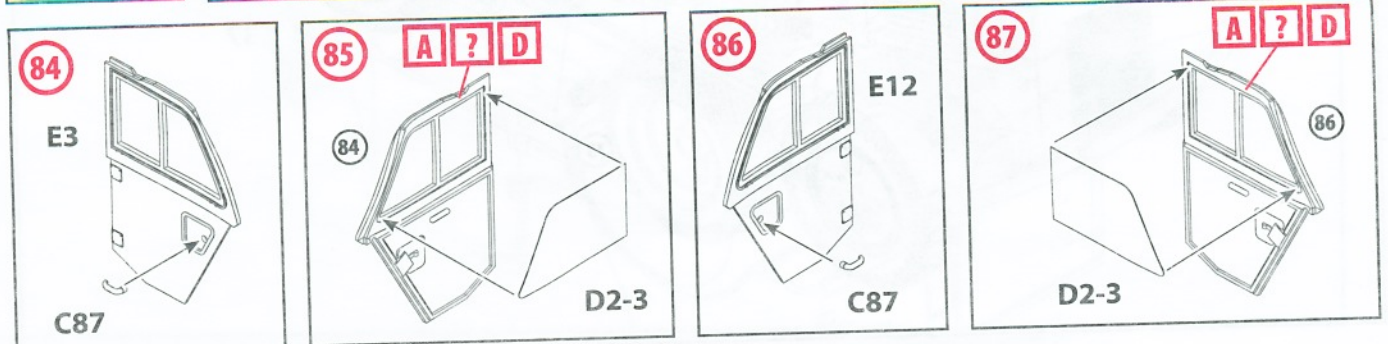
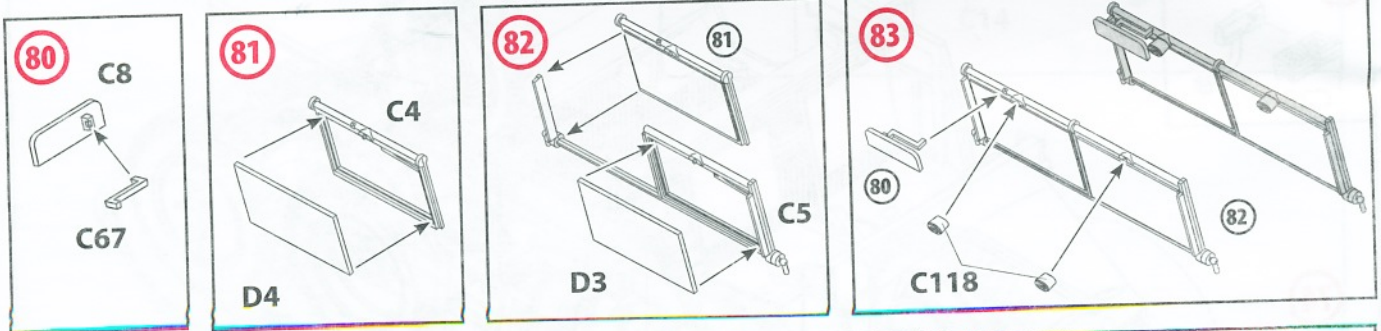
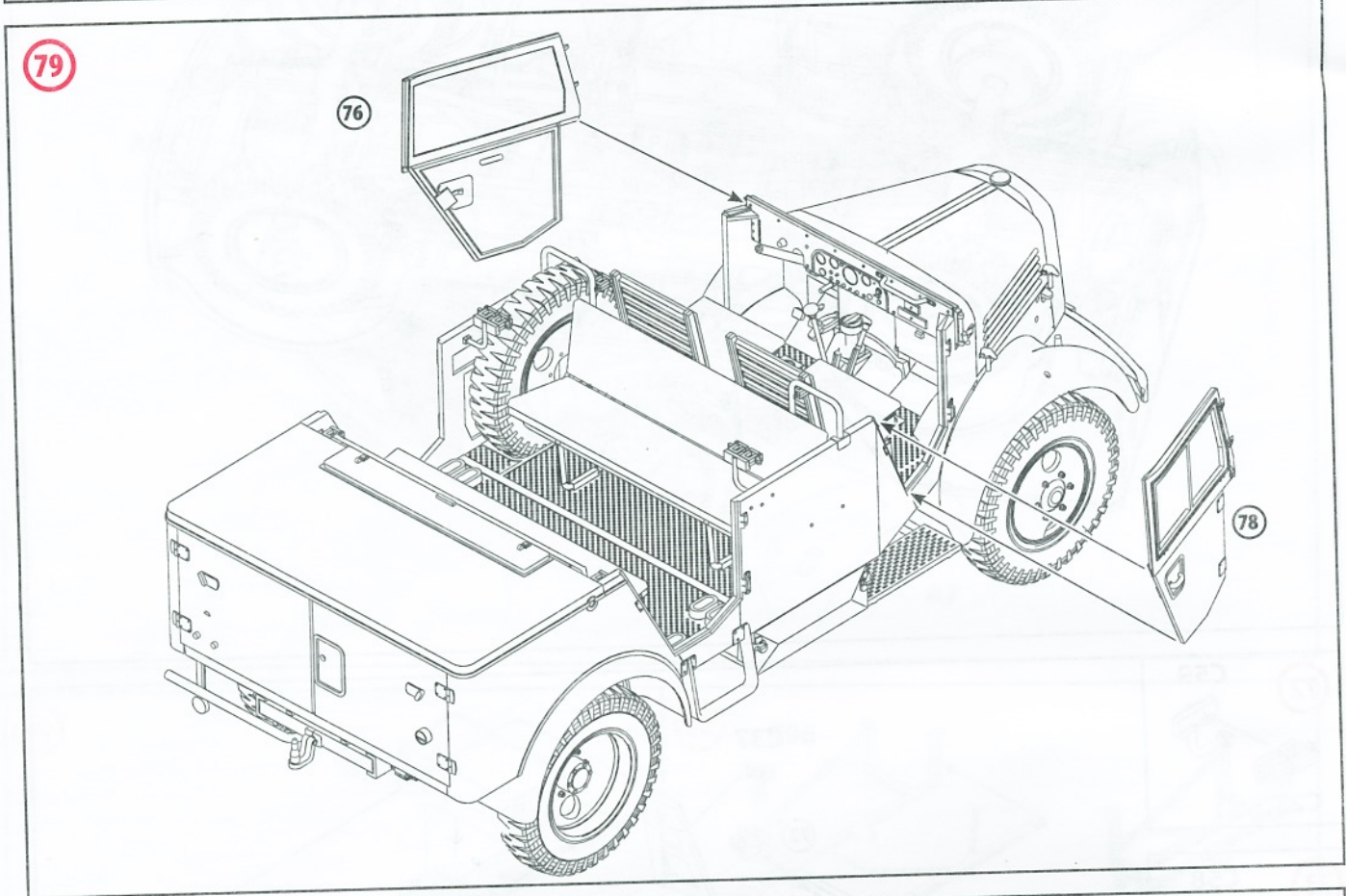
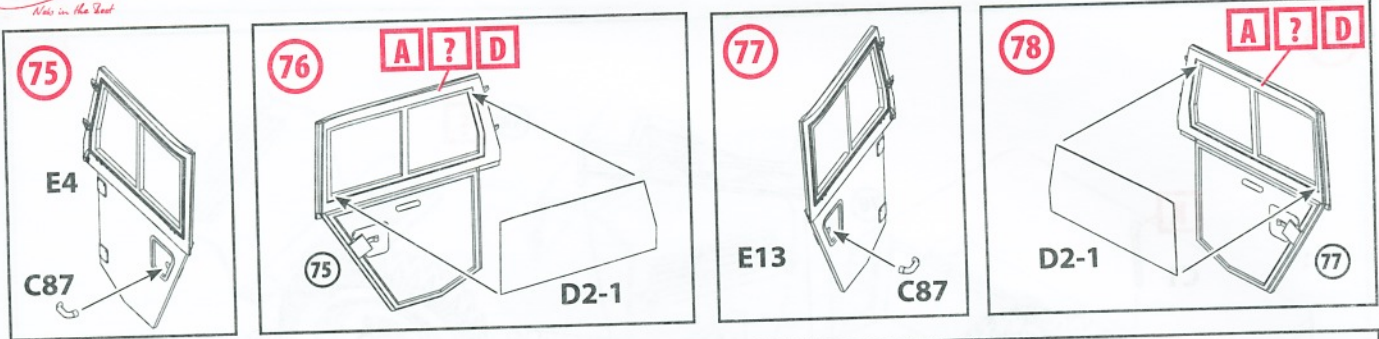

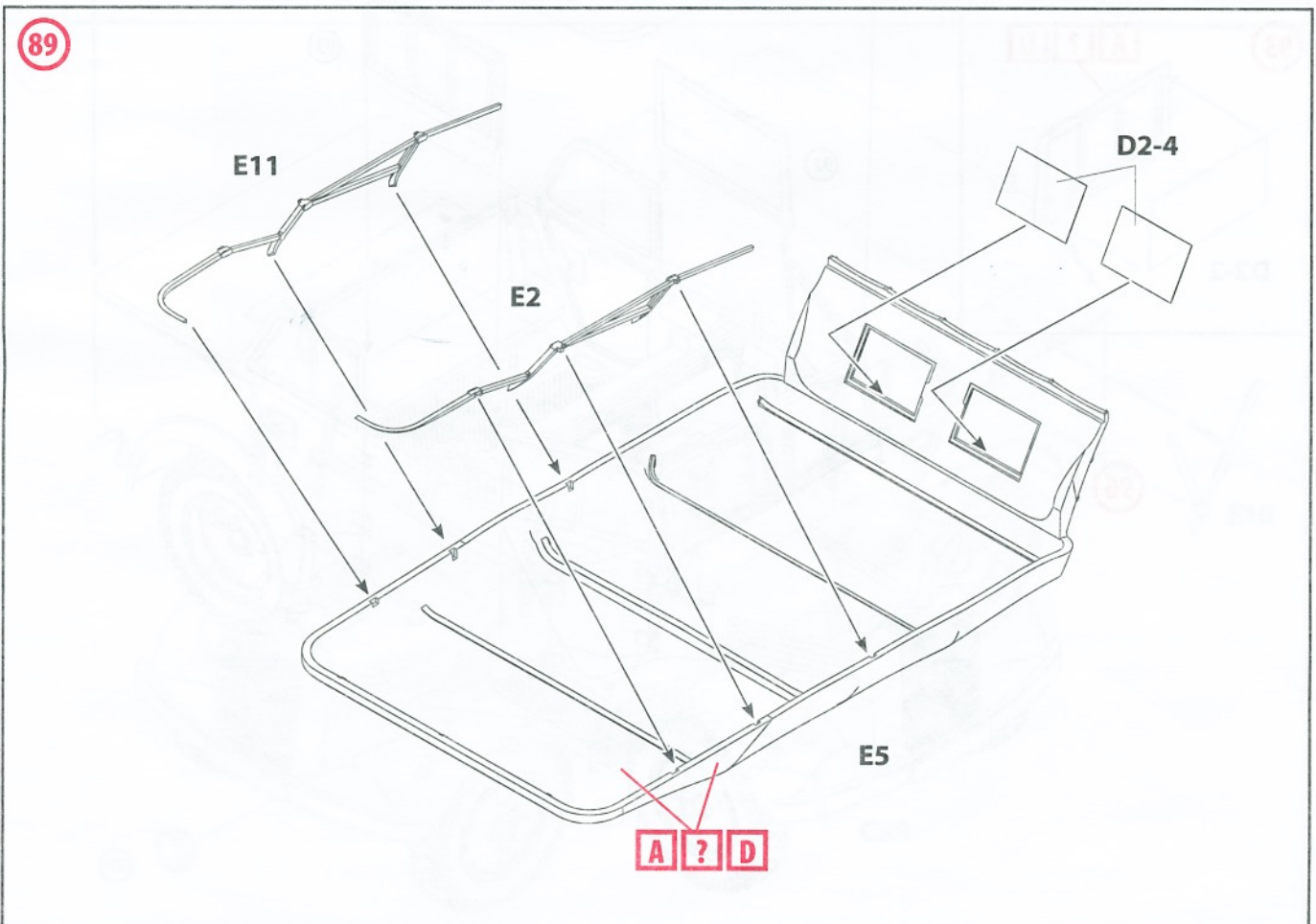
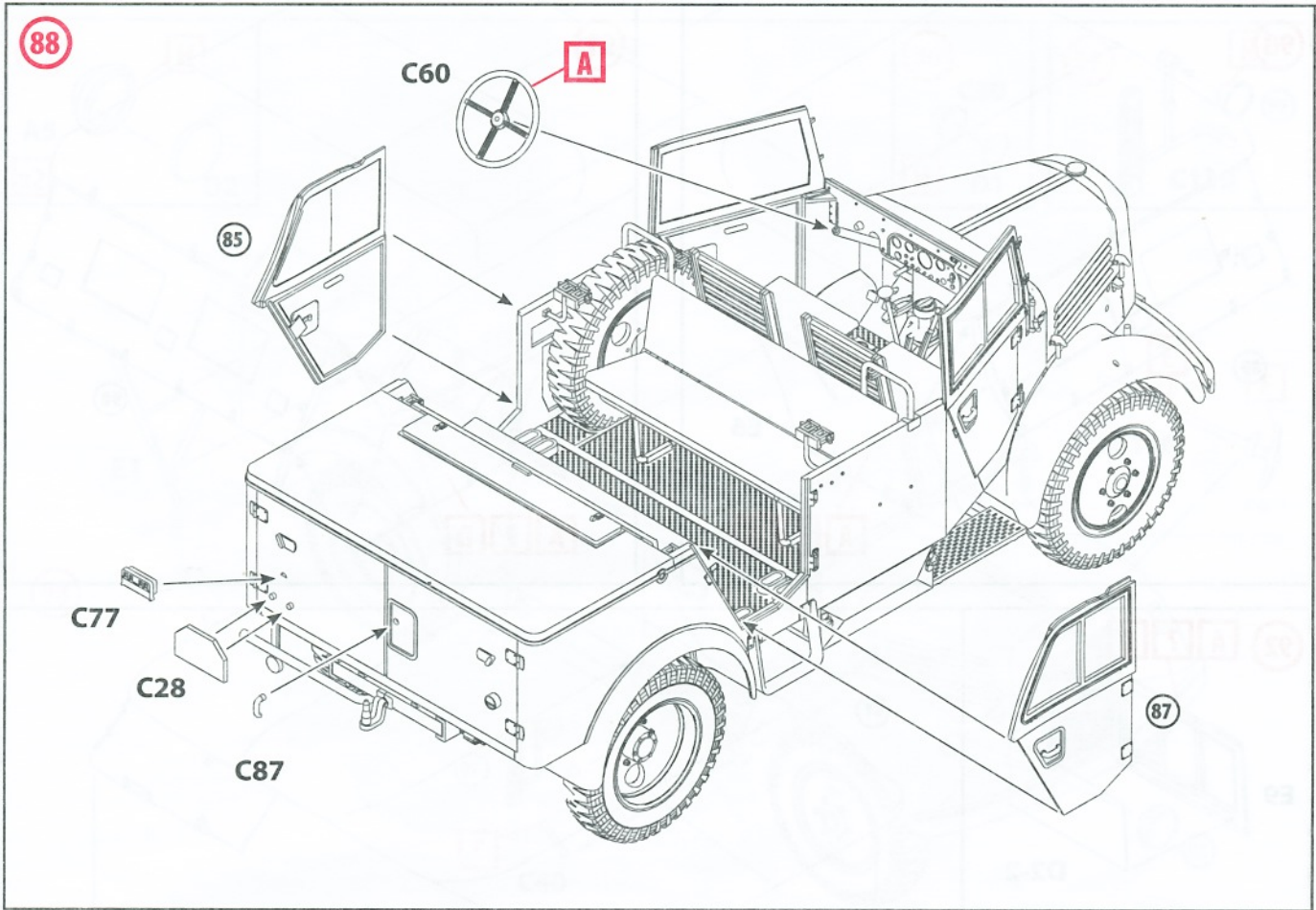

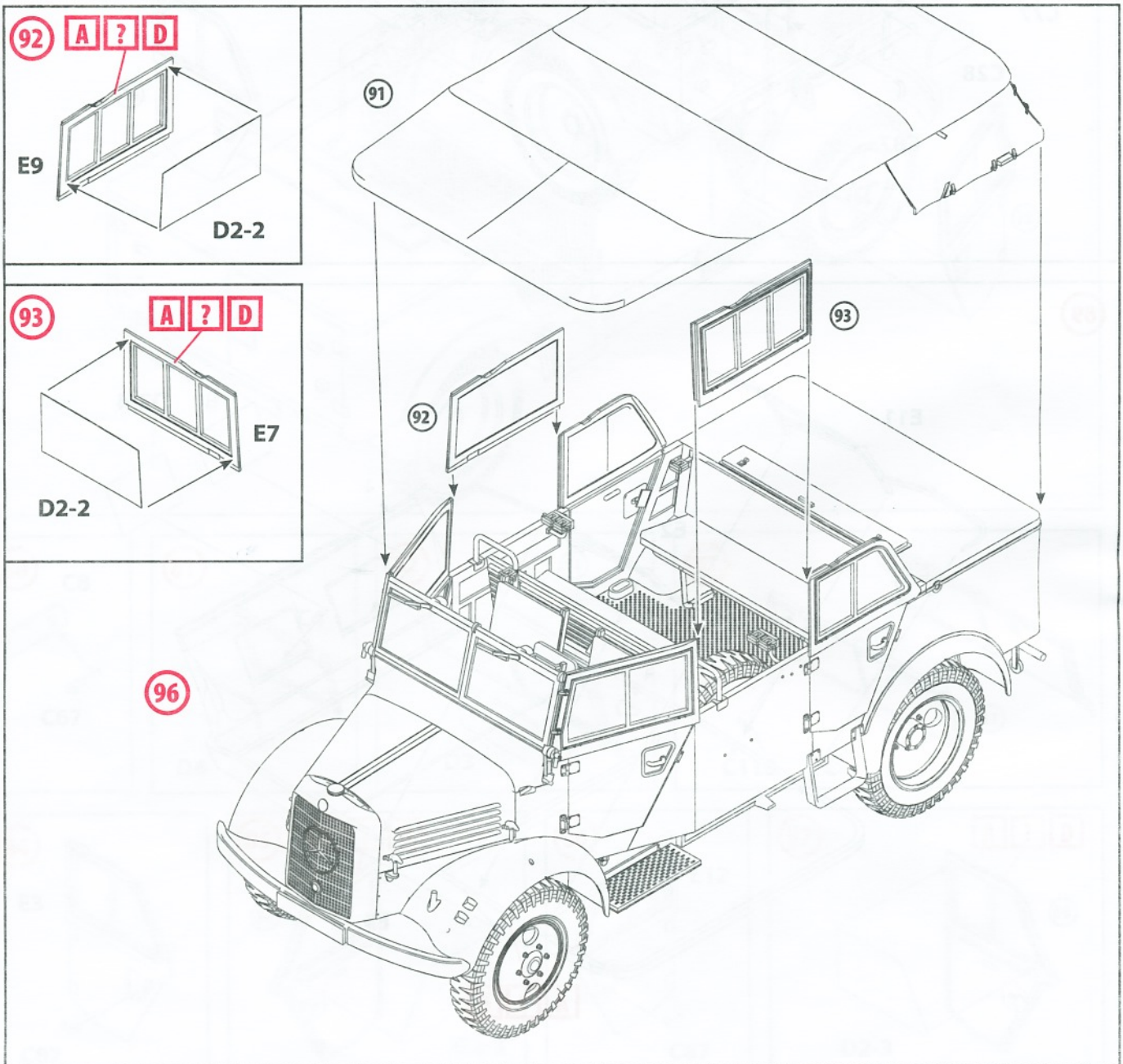
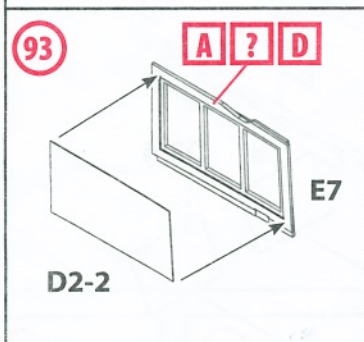
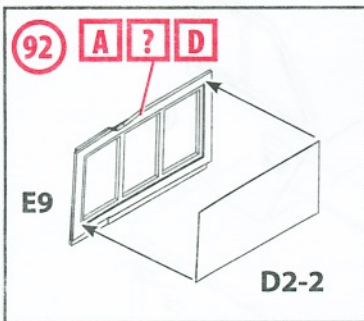
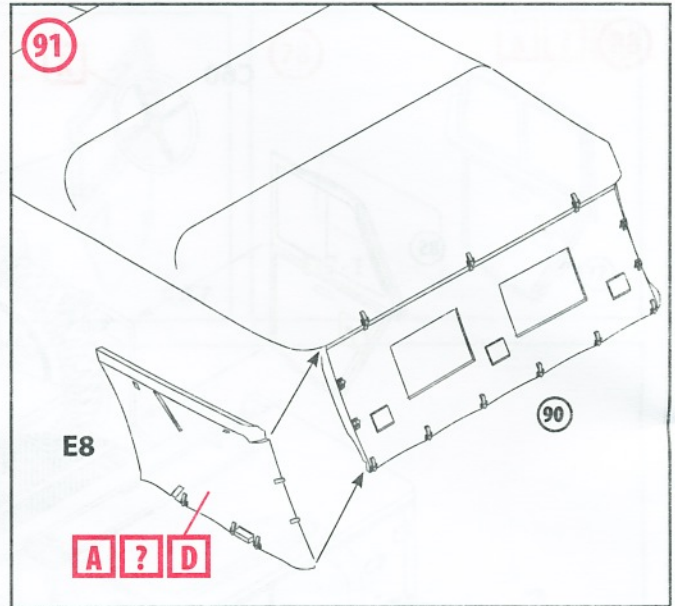
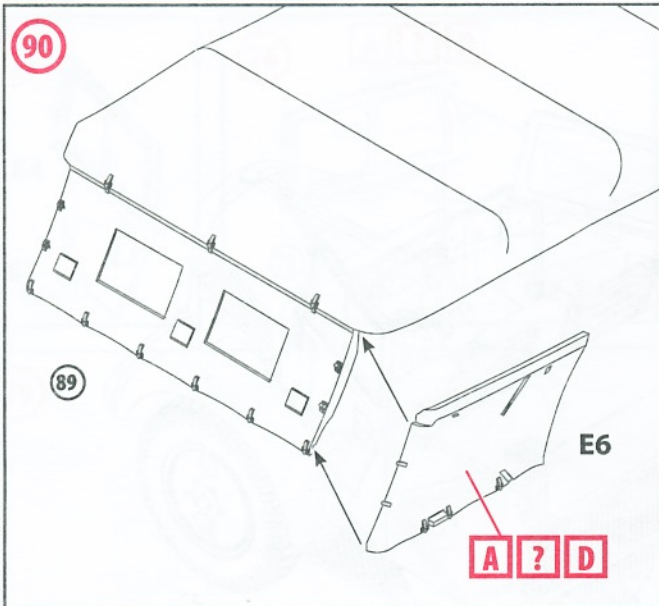

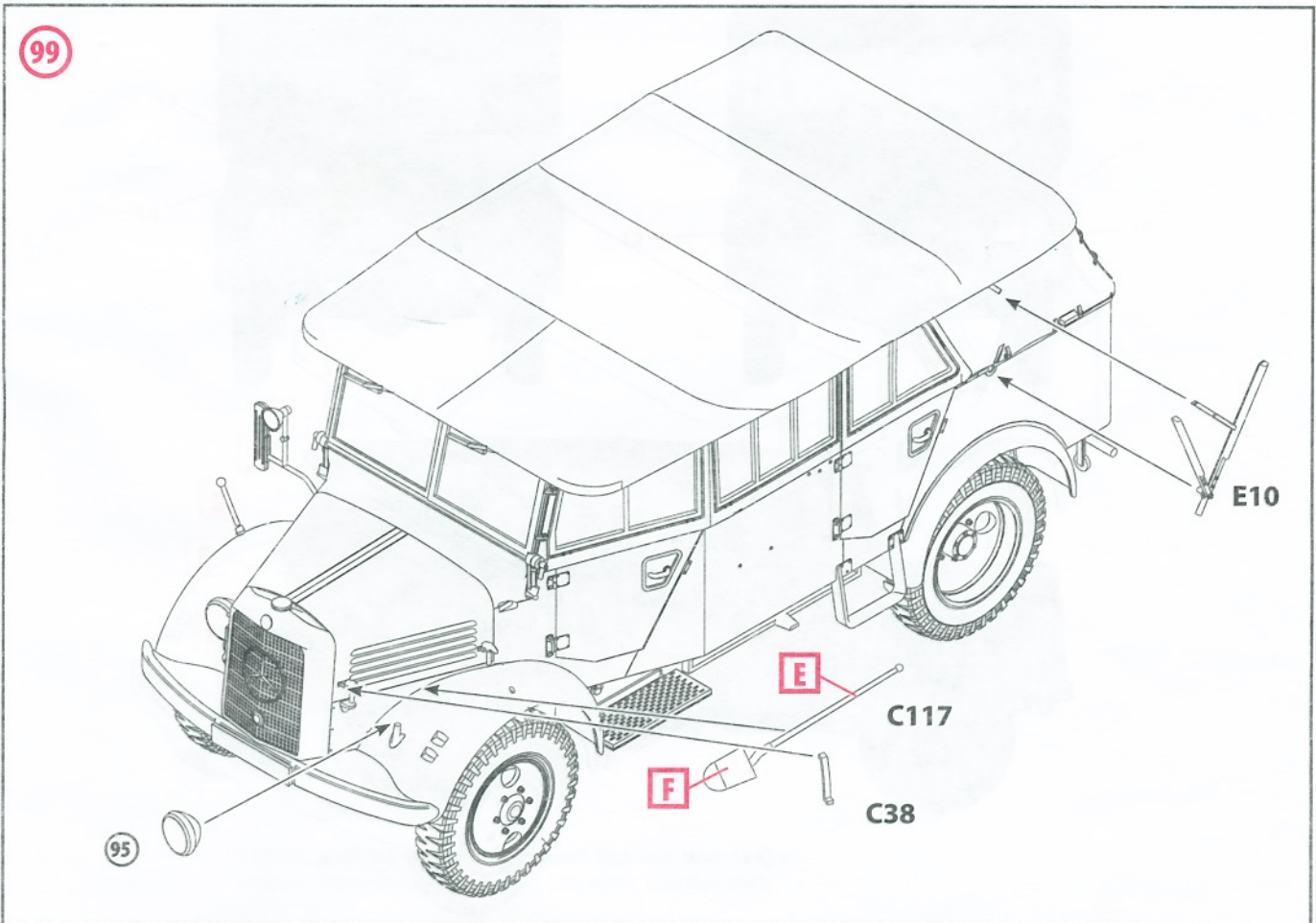
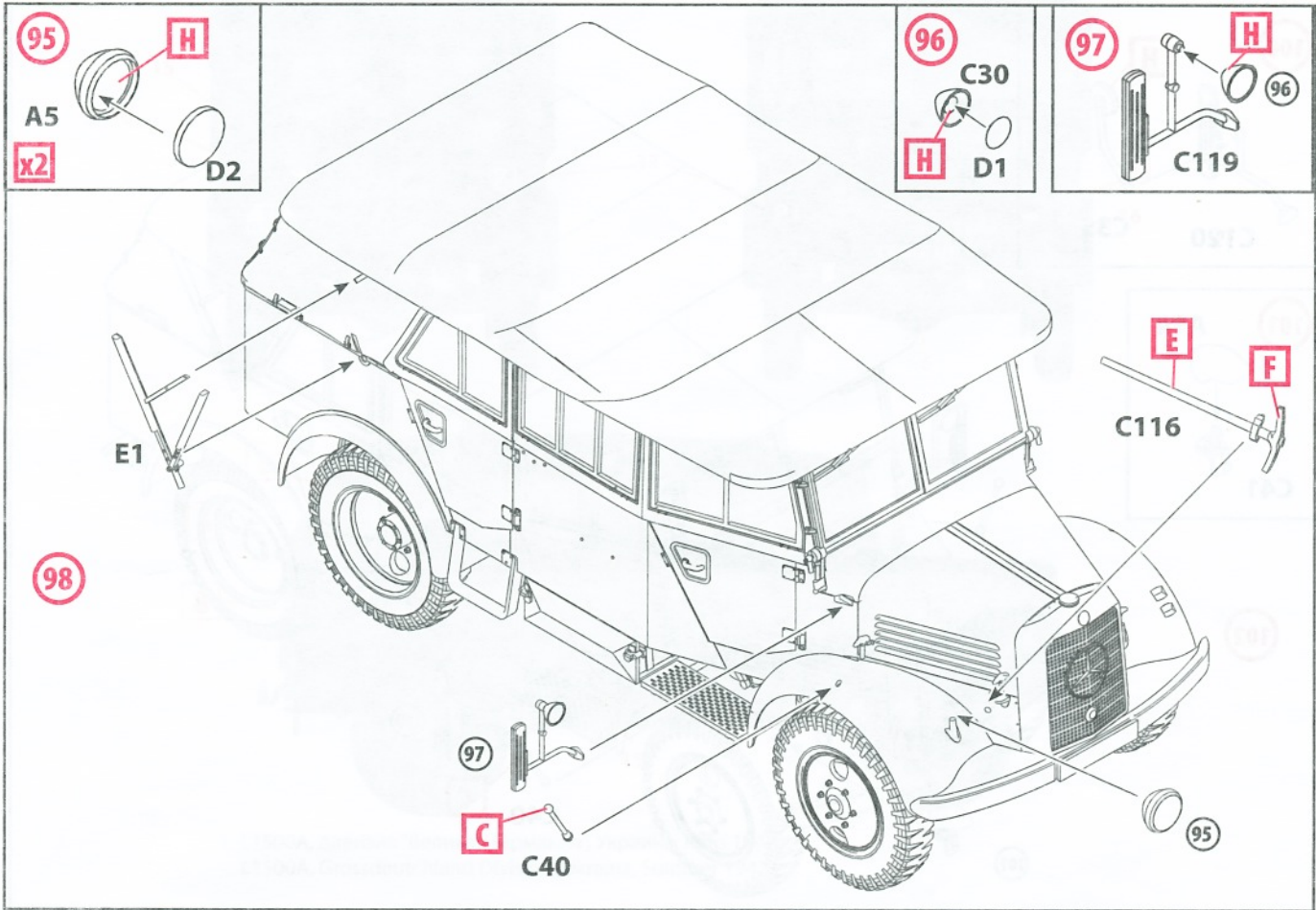

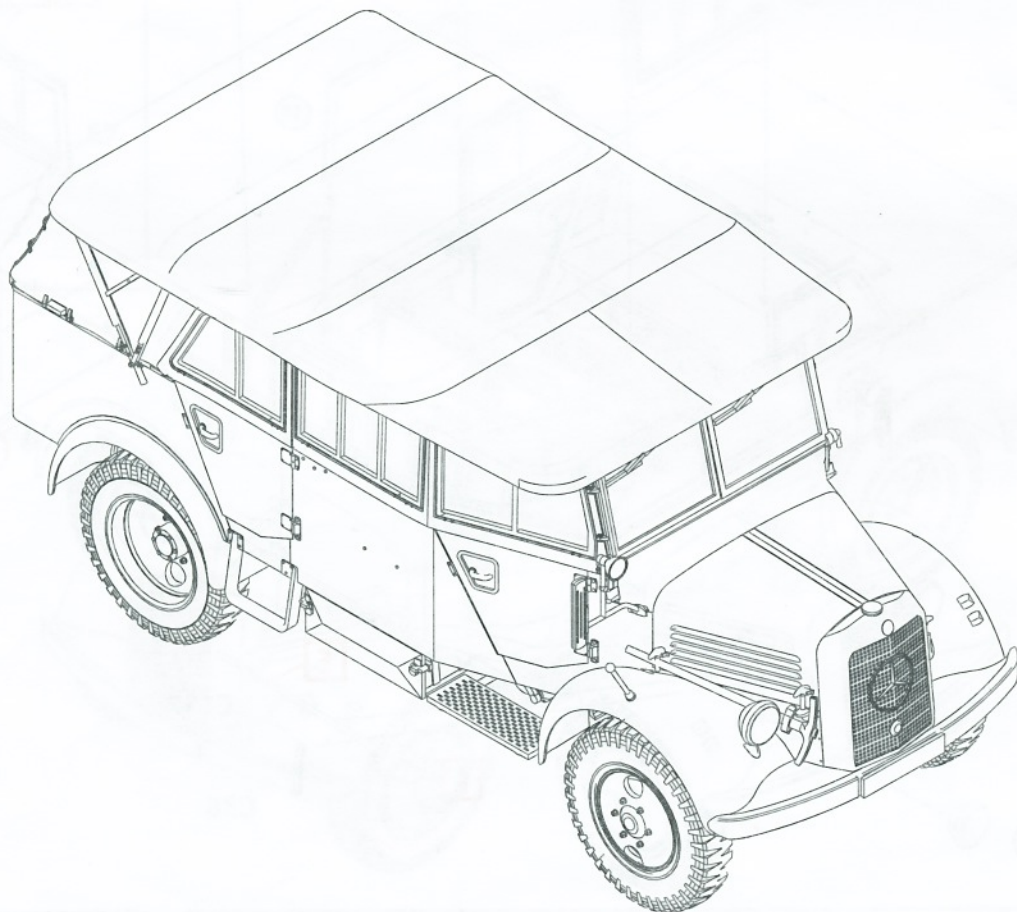
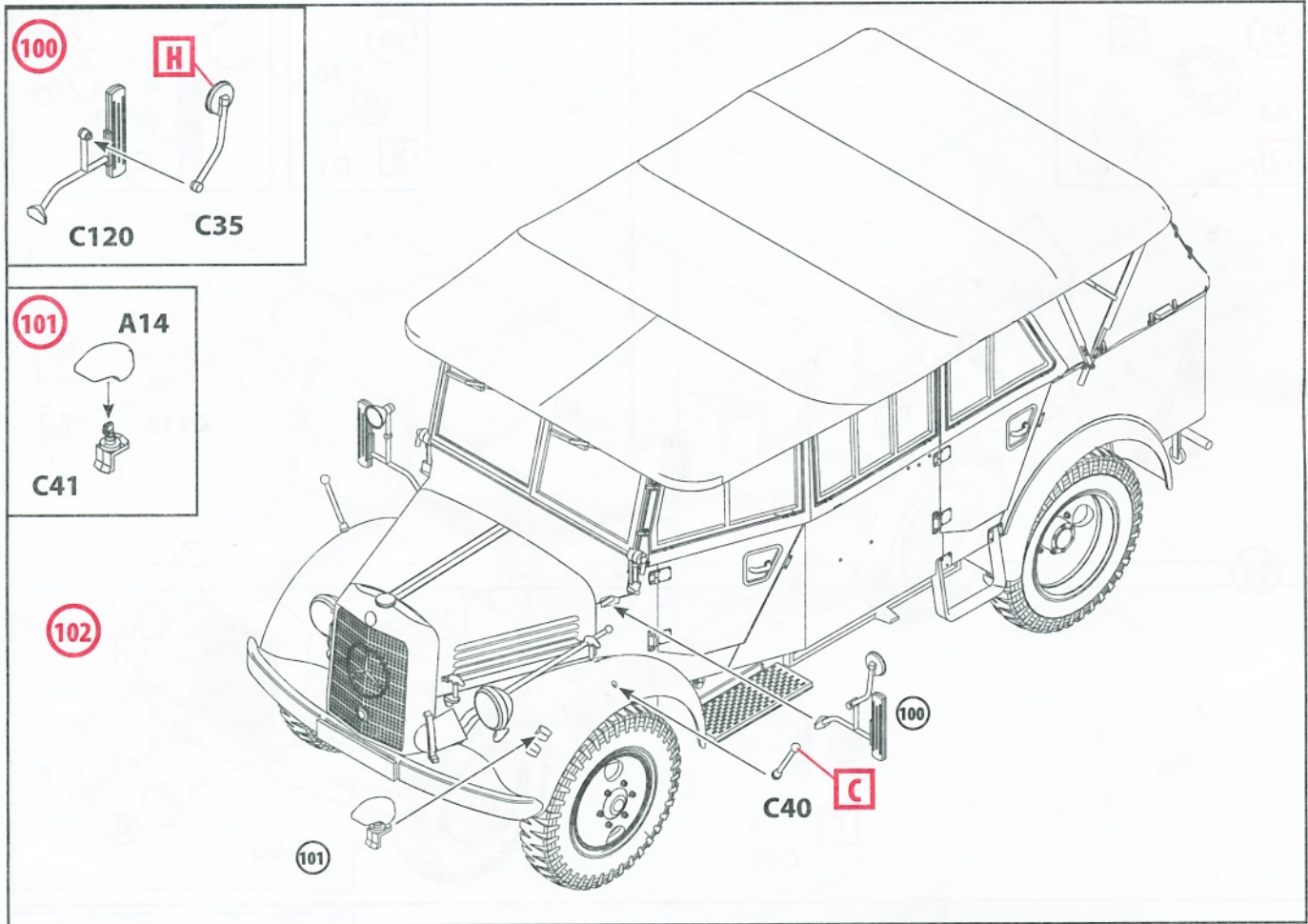

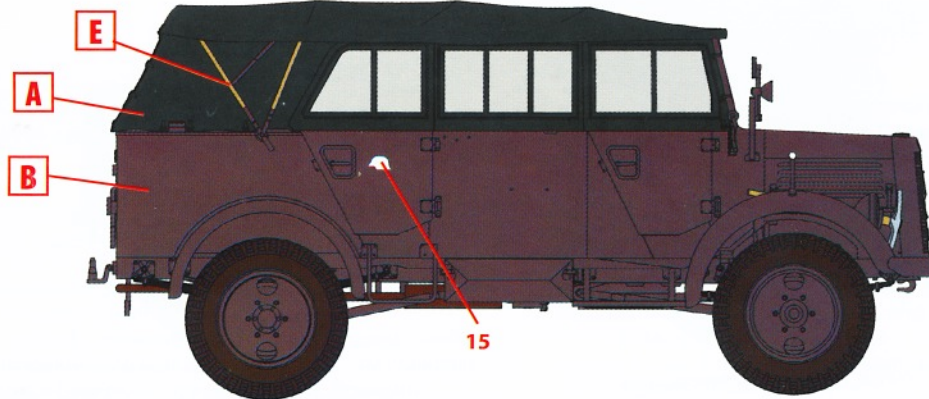
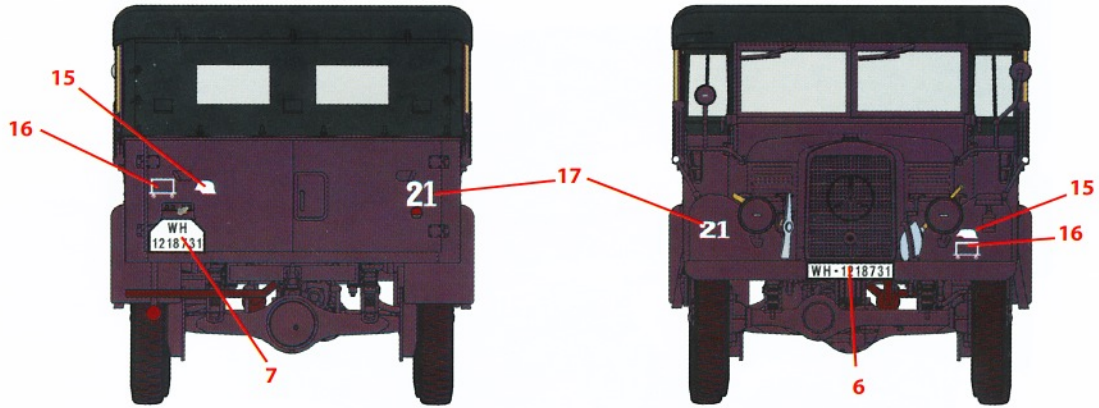

1. L1500A, дивизия "Великая Германия", Украина, лето 1942 г.
L1500A, Grossdeutschland Division, Ukraine, Summer 1942

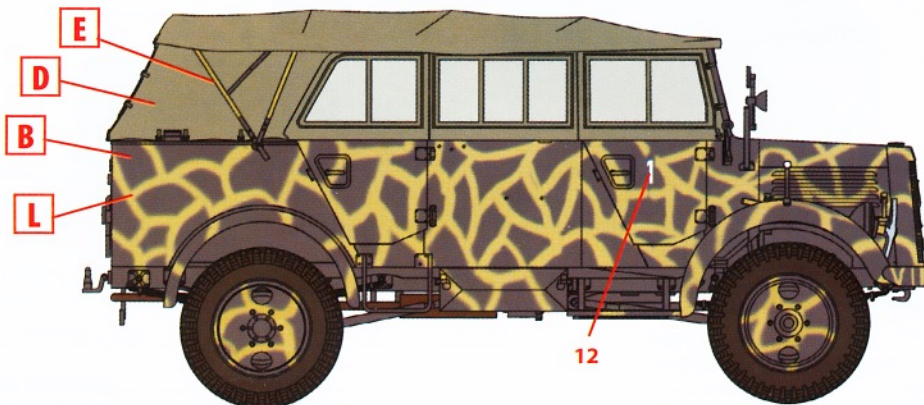
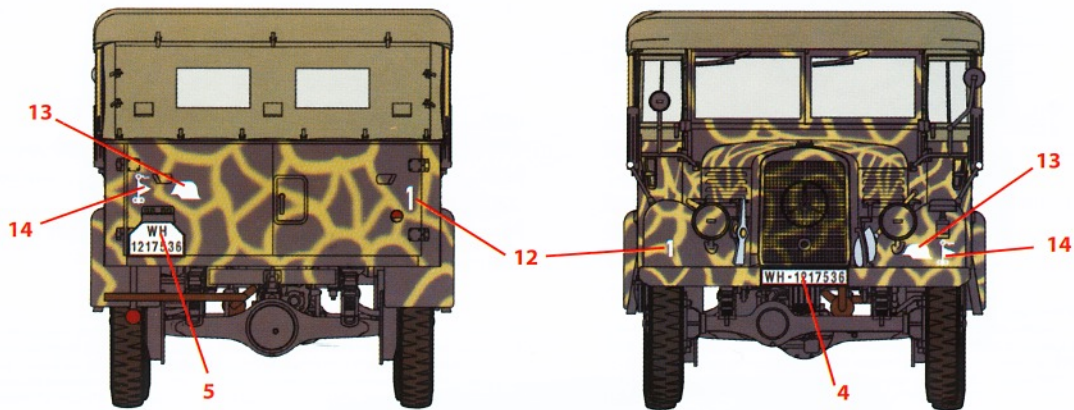

2. L1500A, дивизия "Великая Германия", Харьков, лето 1942 г.
L1500A, Grossdeutschland Division, Kharkov, Summer 1942

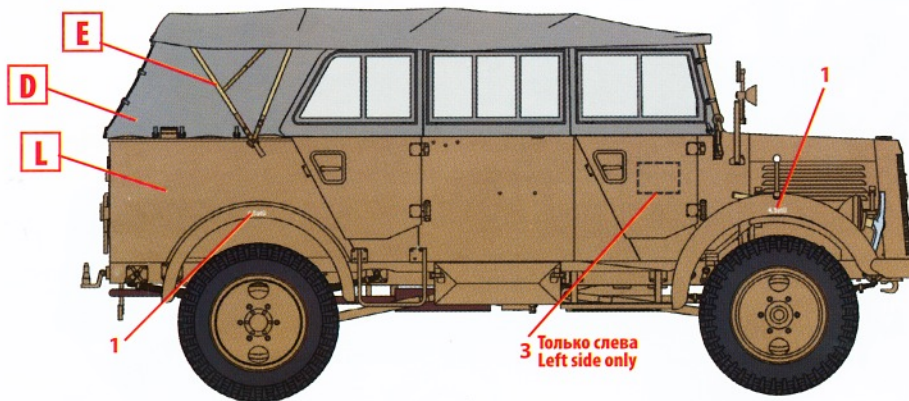
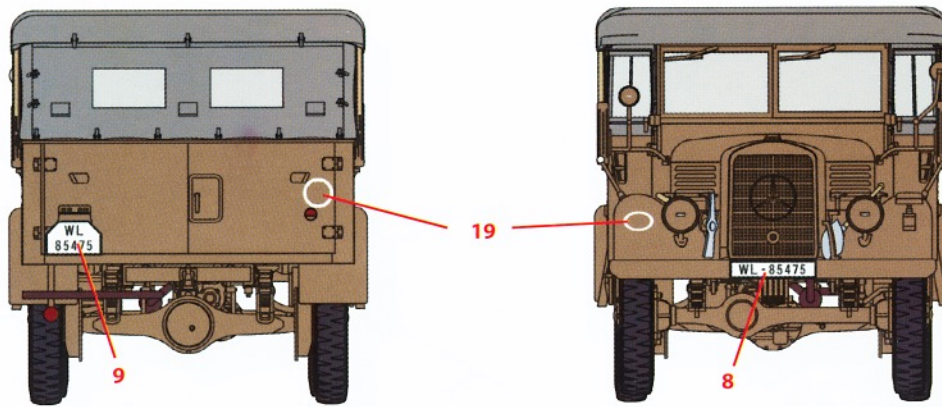

3. L1500A, Северная Африка, лето 1942 г.
L1500A, North Africa, Summer 1942

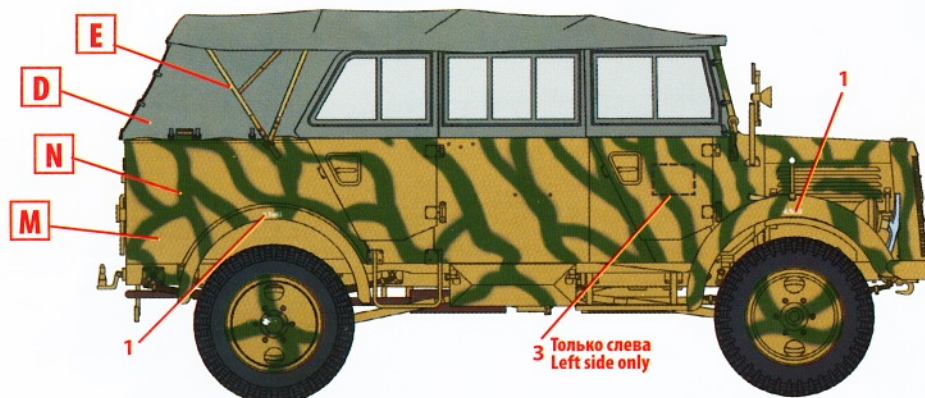
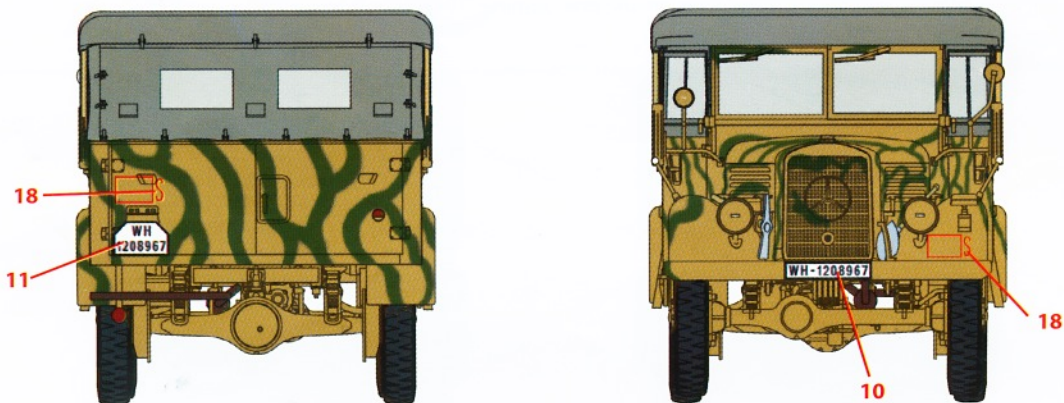

4. L1500A, Италия, лето 1944 г.
L1500A, Italy, Summer 1944

ООО ICM Холдинг
ул. Бориспольская 9, строение 64,
02099, Киев, Украина
Тел./факс: +38(044) 369 54 12
E-mail: export@icm.com.ua



www.icm.com.ua

ICM Holding
Borispolskaya, 9, build. 64,
02099, Kiev, Ukraine
Tel./Fax: +38(044) 369 54 12
E-mail: export@icm.com.ua