



# U.S. ARMY

## 1/4 TON 4x4 UTILITY TRUCK

# M38A1

The U.S. Army introduced the M38A1 in 1953 to replace the M38 1/4 ton truck, an earlier model. The M38A1 was powered with a new overhead valve 4 cylinder engine that required the hood to be 4 inches higher which also shaped newly designed streamlined hood and fenders. M38A1 also featured production integrated Deep Water Forging system and two body variations. Wheel base lengthened M170 Front line Ambulance and M38A1/C 106mm recoilless rifle truck versions, all were served in U.S. ground Forces over the next 20 years including early half of Vietnam War till replaced with M151 series 1/4 ton truck in 60' to 70's.

The M38A1 was widely used by Israel Army in Middle east with a variety of conversion. The M38A1 soldiers on and in many third world countries and the M38A1 is still in front line services with its sturdy body and tough engine. Body design was later used best selling Civilian 4x4 until end of 80'.

1953年、米陸軍はそれまでのMB、GWP、M38 1/4トン車に替わる車輦として、新型のOHV4気筒エンジンを搭載したM38A1を登場させた。M38A1は、50年代の米軍戦術車輦特有の丸みを帯びたボンネットとフェンダー、24ボルト電装を装備し、生産段階で全車に完全防水装置が施されていた。また、ホイールベースを延長した野戦救急車M170や、106mm無反動砲を搭載するための特装ボディを持つ、M38A1C等のバリエーションが存在し、これらのM38A1系車輦は、頑丈なボディとタフなエンジンによる高い信頼性から、ベトナム戦争の前半を含む約20年間の長きにわたって活躍し、60年代末から70年代にかけて M151シリーズと交代するまで米地上軍によって使用されたのであった。さらに、イスラエル軍によって中東戦争の際に広く活躍した他、多くの第三世界でも使用され、その一部は今なお第一線に配備されている。後に、ボディデザインはそのまま、民間向けの四輪駆動車として発売されると、たちまちベストセラーとなり、80年代の終わりまでその生産が続けられたのであった。

1950年、美軍推出，新型戰術車輦 M38A1 1/4T 4x4，用它種以取代二次大戰的 MB、GWP 系統以及大戰後的 M38。M38A1 的車款與美軍 50 年代的戰術車輦有著共通之處，車身採稍許的流線造型，是一嶄新的創舉，24V 的電流供應，車體變寬大，配備 OHV ENGINE，從生產階段開始，便採用防水裝置，1/4 車款的多用途性，也是從 M38A1 開始，譬如：車身加長成為野戰救急車 M170，以及搭載 106mm 無座力砲的 M38A1C 等，這些都是 M38A1 的衍生車輦。

在 60 年代中期，M151 系列尚未取代之前，它曾在越戰中活躍過，以色列在中東戰爭時大量地投入該型車輦，M38A1 是與 MB、GWP 有直接的血緣關係，它是美軍最後的 1/4T 卡車，並一直受到士兵的愛戴，直到 70 年代初，才卸下光榮的歷史任務。

由於它如此屹立不搖，以致當今美國尚有多處民兵基地仍妥善保存、及使用它。

1. 穴を開ける  
OPEN HOLE  
OFFEN  
FARE UN TRUO  
FORO APERTO  
HACER AGUERO  
BURA

2. 接着剤を塗る  
REMOVE  
ENTRENER  
RETRER  
SEPARARE  
CORTAR  
SEP

3. 2つの穴を開ける  
2 SETS NEEDED  
ZWO DOHRER  
DEUX SETS NECESSAIRES  
NECESSARIE 2 SERIE  
SE NECESITAN DOS PREGAS  
ZWEI LOCHER

4. 穴を削る  
BITE BEGON  
BITE IL VOUS PLAT  
PEGARE  
PEGAR  
BIT

5. 穴を開ける  
OPTIONAL  
HACER AGUERO  
FACULTAT  
FACULTATIVO  
OPZIONALE  
TORNARE

6. 穴を埋める  
APPLY DECAL  
HEAR ASSEMBLD  
APPLIQUE DECALOMANE  
APPLIQUE DECALOMANE  
PAPER CALCOMANIA  
BILKLEB

7. 接着剤を塗る  
INSTANT GLE FOR METAL  
METALLKLEBER  
COLLE A METAL INSTANTANE  
COLLA INSTANTANEA PER METALLI  
COLAS PEGAMENTO INSTANTANEO  
METALLKLEBER

8. 穴を開ける  
FILL HOLE  
SCHLIESSEN  
BOUCHER LE TROU  
FORO PENO  
ESPLUR IL AGUERO  
EPLUR

9. 穴を開ける  
DO NOT DEMENT  
NIGHT ALERIN  
NE PAS COLLER  
NON INCOLLARE  
NO PEGAR  
FRAGILE

Color list: 塗料表

Color	Brand	GSI Creos (Gunze Sangyo)			Humbrol	Revell	Life Color
		Hobby Color	Mr. Color	Mr. Color Spray			
Olive drab(2)	橄欖綠	H-72	C-38	J-38	66	46	UA006
Olive drab(1)	橄欖綠	H-58	C-12		155		UA103
Gold	金	H-9	C-9	J-9	16		LC75
Steel	黑鐵	H-18	C-28	J-28	53	91	LC76
Wood brown	木棕	H-37	C-43	J-43	10	81	UA085
Silver	銀	H-8	C-8	J-8	11	90	LC74
Khaki green	卡其綠	H-80	C-54				
Red	紅	H-3	C-3	J-3	19	31	LC56
Burnt iron	燒鐵	H-76	C-61		53		UA061
Flat black	消光黑	H-12	C-33	J-33	33	8	LC02
Semi gloss black	半光黑		C-92	J-92	85	9	

Method For Applying Decals:

1. Clean Model Surface With Wet Cloth.
2. Cut Out Of Decal Sheet And Dip Them In Water For 3 Seconds.
3. Place it on proper position on model.
4. Slide off base paper leaving decals On Model With Wet Finger Tip.
5. Move Decals To Exact Position, Push Out Excess Water Under Decal With Soft Cotton Cloth.
6. When Decals Get Dry Then Complete.

水貼紙使用說明:

1. 將模型表面擦乾淨
2. 將貼紙剪下泡入清水中約 3 秒
3. 將泡過之水貼紙取出置於欲貼處
4. 用溼手指將貼紙移至其精確位置
5. 將貼紙調整至適當位置並輕輕拭去水份
6. 待其自然乾後即告完成

1

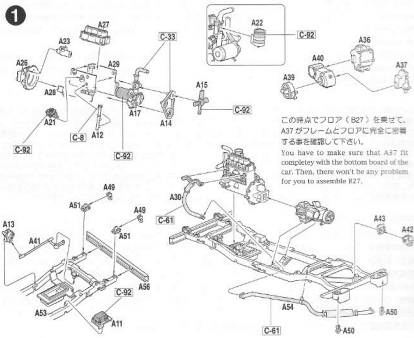

この時点でフロア (B27) を乗せて、A37 がフレームとフロアに完全に密着する事を確認して下さい。

You have to make sure that A37 fit completely with the bottom board of the car. Then, there won't be any problem for you to assemble B27.

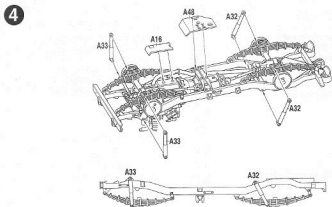
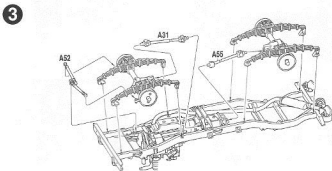
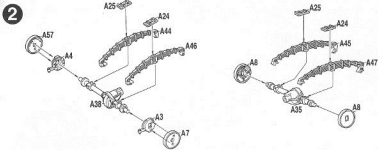

5

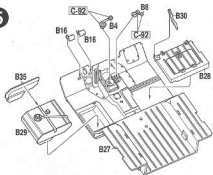

偵察車式樣請鑽預孔  
Please bore a hole on the model of  
the reconnaissance car.

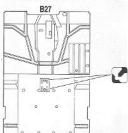

6

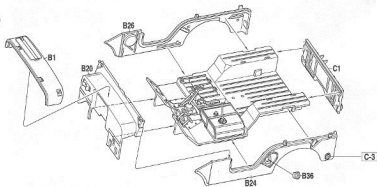

7

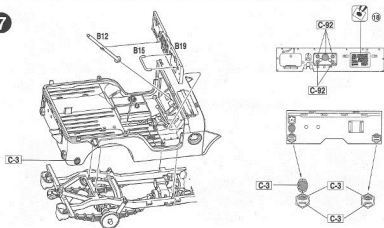

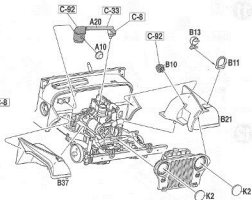
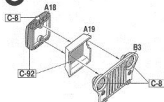
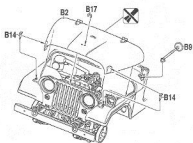
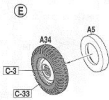
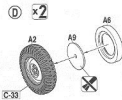
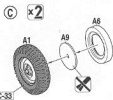
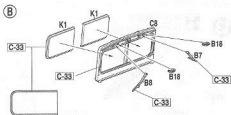
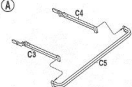
**8****9****10**

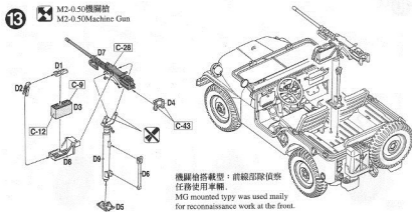
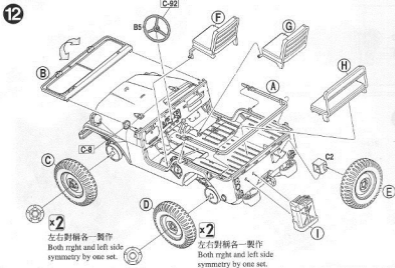
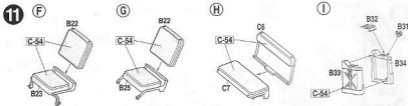

**A: U.S. ARMY**

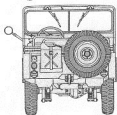
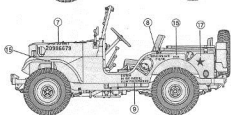
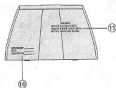
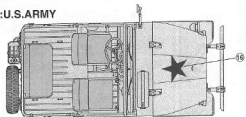

**B: U.S. ARMY IN GERMANY 1959**

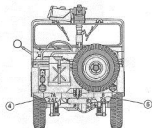
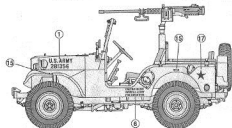

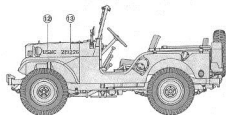
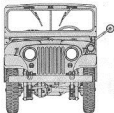
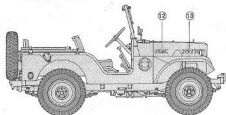
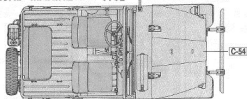

Instructions:

If for some reason, you are not fully satisfied or have questions concerning our product; Please use the form provide, and send it to our nearest representative or mail it directly to our office.

We will deal with that A.S.A.P.

限台灣地區使用 For Taiwanese use only!

總代理：戰鷹企業 客服中心收本公司將盡速為您處理  
請將本表與該部品相同金額之郵政匯票一同寄至



**AF 35S17**  
Parts Replacement Form

- A parts
- B parts
- C parts
- D parts
- K parts
- decal parts
- 

Reason for replacement:  Missing  broken

Signature: \_\_\_\_\_



**AF 35S17**  
零件補充申請表

申請人  
姓名 地址 電話  
: : :

- A部品零件 — NTS160
- B部品零件 — NTS140
- C部品零件 — NTS100
- D部品零件 — NTS100
- K部品零件 — NTS50
- 水貼紙 — NTS100

(請準) 總計 NTS \_\_\_\_\_

零件補充原因: (請於 打)  
原包裝  遺失或  破損  
製作途中  遺失或  毀損  
 補充多餘零件  
其他原因 \_\_\_\_\_



# AF 35S19 M38A1C 106mm 中華民國海軍陸戰隊

 Body Color: IJN Green

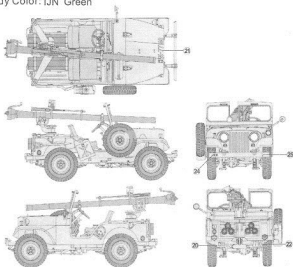

# AF 35S17 M38A1 中華民國海軍陸戰隊

 Body Color: IJN Green

