

NÁVOD / INSTRUCTION

Morane Saulnier AI

1/48

CZ - Historie

V roce 1917 navrhla a postavila firma Morane Saulnier dva nové stíhací prototypy, hornoplošný MoS 27 a dvouplošný MoS 28. Hornoplošný MoS 27, vyzbrojený jedním kulometem, byl poháněn rotačním devítiválcem Gnome Monosoupape 9Nb. S tímto motorem dokázal prototyp vystoupat až do výšky 8.000 m (pilot byl vybaven dýchačem). Testy nové stíhačky proběhly v létě 1917, byly úspěšné, o měsíc později byl otestován prototyp MoS 29 s výzbrojí dvou kulometů. Nakonec byly objednány obě provedení. Firma Morane Saulnier tento typ označovala písmeny AI.

Do výzbroje bojových jednotek byly nové stíhačky zařazeny během ledna 1918. Jejich výkony byly na úrovni Spadů XIII. Bohužel se objevily problémy s pevností křídla a s motorem Monosoupape 9Nb. Morane Saulniery AI se tak dostaly do výzbroje jen tří escadrille (č. 156, 158 a 161). Z první linie byly staženy v květnu 1918 a tak skončila krátká bojová služba Morane-Saulnier A.I. Všechny letky převzaly 20.května náhradou stroje SPAD 13. V podstatě neuvážené stažení výkonné stíhačky z první linie však neznamenalo konec její kariéry. S slabšími typy motorů byl typ dále vyráběn jako cvičný pod označeními MoS.30 (s motorem Le Rhône 9Jb o výkonu 89 kW, nebo motorem Le Rhône 9Jby o výkonu 101 kW) a MoS.30 bis (verze se sníženým výkonem motoru Le Rhône 9Jby o výkonu 67 kW). Nakonec bylo vyrobeno přes 1000 kusů typu AI. Kromě Francie se dostal do výzbroje Belgického, Švýcarského, Polského a Japonského letectva.

Rozpětí: 8,51 m, Délka: 5,65 m, Max. rychlost: 221 km/h, Výzbroj: 1-2x synchronizovaný kulomet Vickers ráže 7,7 mm, Dostup: 7.000 m, Dolet: 1 hod 45 min

GB - History

Morane Saulnier had designed and built two new fighter prototypes in 1917. These were high wing MoS 27 and biplane MoS 28. The high wing monoplane MoS 27 was powered by 9-cylinder Gnome Monosoupape 9Nb rotary engine and equipped with one machine gun. This engine allowed the aircraft to reach 8,000 m (pilot had to wear respirator). The trials of the new fighter were carried out in summer 1917 and were successful. One month later, Mos 29 equipped with two machine guns was trialed. Eventually, both versions were ordered for production. Morane Saulnier Company designated this type with letters AI.

During January 1918 these new fighters were assigned to combat units. The performances of AI were comparable to Spad XIII ones. Unfortunately, the wing rigidity and Monosoupape 9Nb engine problems occurred. Nevertheless, only three escadrilles (No 156, 158 and 161) were equipped with Morane Saulnier AIs. In May 1918 were AIs withdrawn from the first line service and so their short combat service ended. On May 20 were all units re-equipped with Spad XIII's. The fore thoughtless withdrawn of a powerful fighter didn't mean the end of it carrier. It was produced as a trainer MoS 30 with less powerful engines (89 KW Le Rhône 9Jb or 101KW Le Rhône 9Jby) and MoS 30 bis powered by Le Rhône 9Jby with lowered output to 67 Kw. Eventually, more than 1,000 AIs were produced. Except of French AF, it was used by Belgium, Switzerland, Poland and Japan.

Wingspan: 8.51 m, Length: 5.65 m, Max. Speed: 221 kmh, Armament: 1-2x synchronized 7.7 mm Vickers machine gun/s, Service ceiling: 7,000 m, Endurance: 1h 45 min.

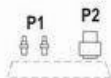
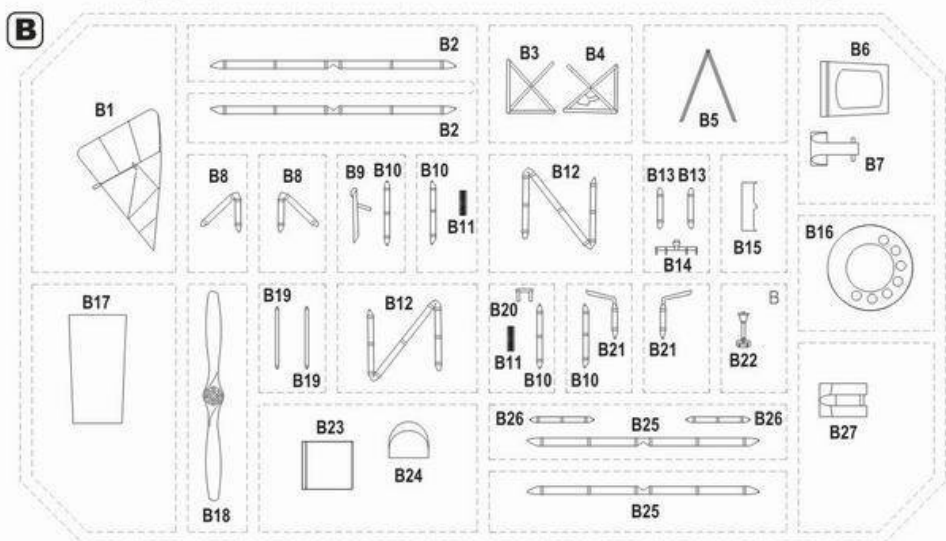
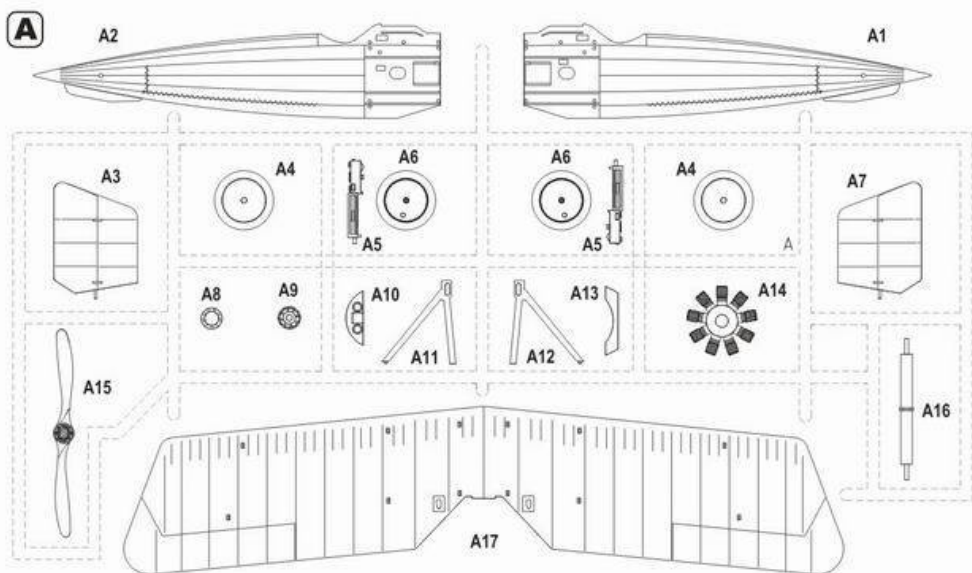

POLYURETHANE PARTS (P)

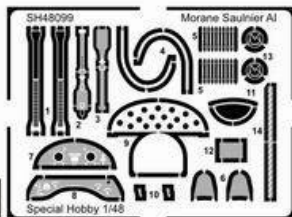

PHOTO-ETCHED PARTS (PE)



FILM (F)



SYMBOLS

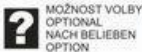

MOŽNOST VOLBY
OPTIONAL
NACH BELIEBEN
OPTION



POUŽÍŤ KYANOAKRYLÁTOVÉ LEPIDLO
INSTANT CYANOACRYLATE GLUE
ZYANOAKRYLÁTKLEBER
ADHESIF CYANOACRYLAT



OHNOUT
BIEGN
COURBER



ZHOTOVIT NOVÉ
BEND
FERTIGSTELLEN
ACHEVER



REZAT/VIRTAT
CUT OFF/DRILL
ENTFERNEN
DETACHER



GSF
colour code

NATRÍT
COLOUR
FARBEN
PEINDRE

1

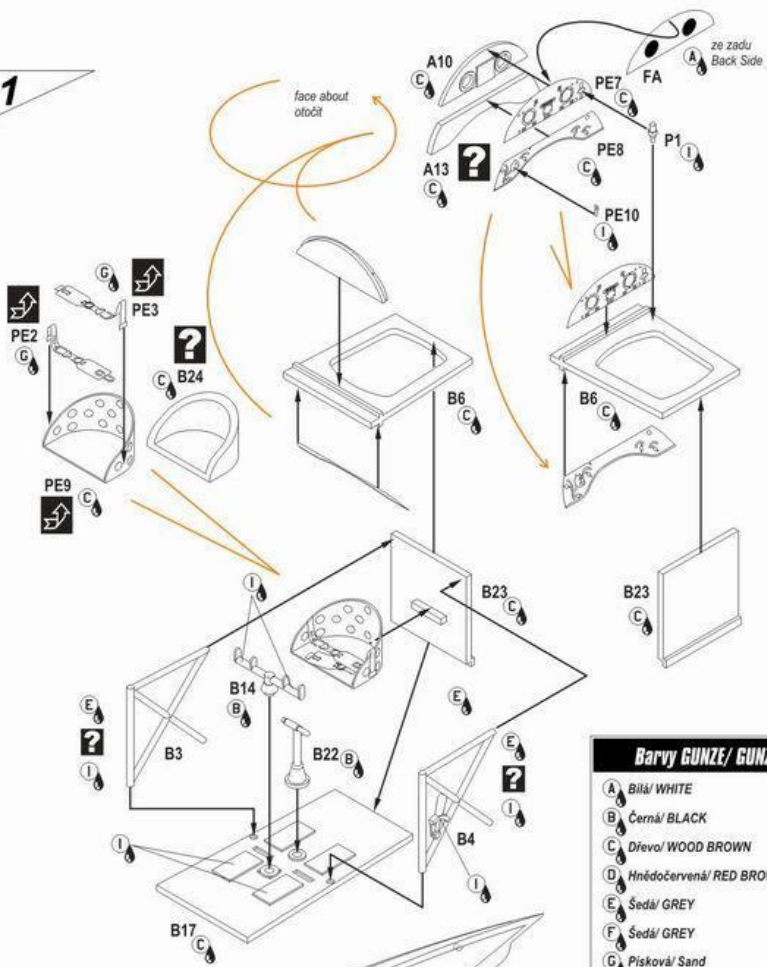

2

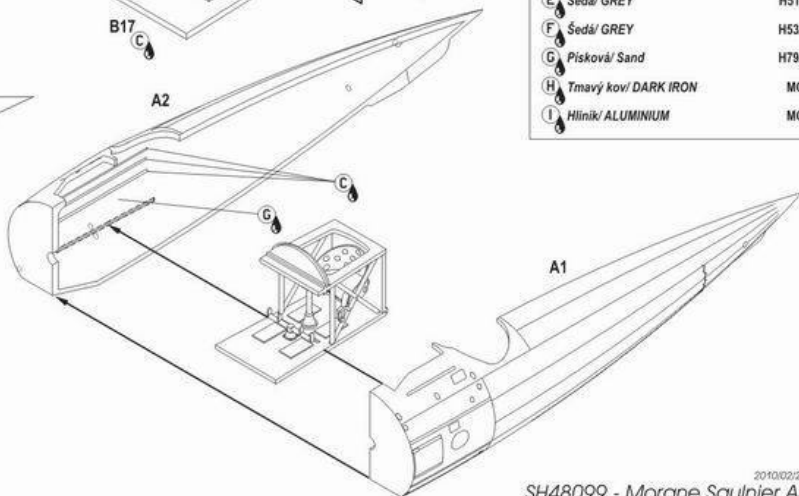

8

3

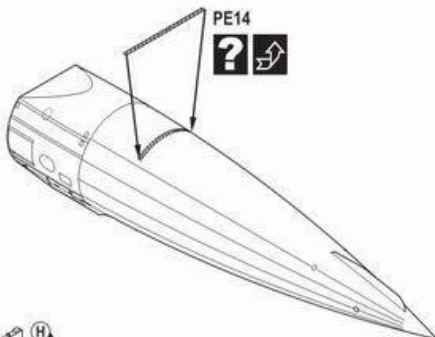
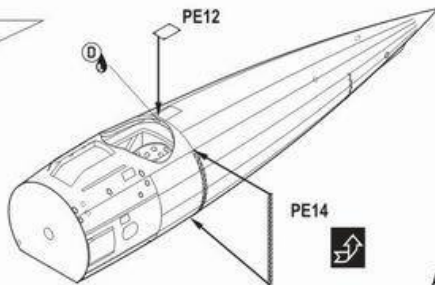

PE14

?



4

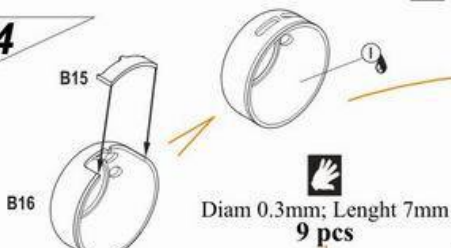

Diam 0.3mm; Lenght 7mm
9 pcs



A5

H

PE6

H

B27

B7

H

H

H

H

H

H

H

H

H

H

H

H

H

H

H

H

H

H

H

H

H

H

H

H

H

H

H

H

H

H

H

H

H

H

H

H

H

H

H

H

H

H

H

H

A5

H

PE6

H

B27

B7

H

H

H

H

H

H

H

H

H

H

H

H

H

H

H

H

H

H

H

H

H

H

H

H

H

H

H

H

H

H

H

H

H

H

H

H

H

H

H

H

H

H

H

5

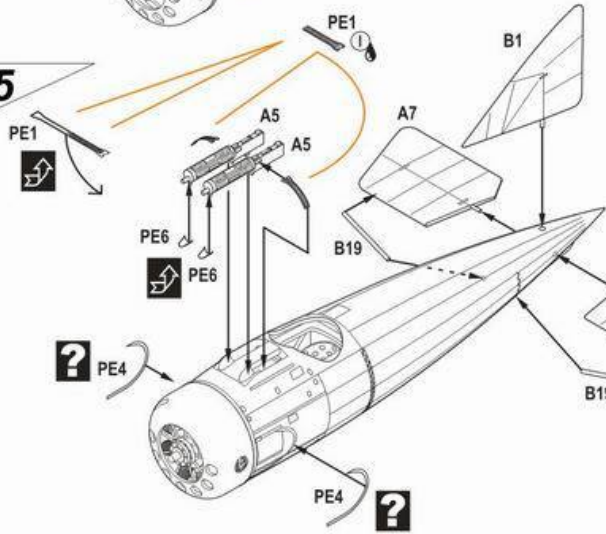

PE1

H

PE6

H

PE6

H

PE6

H

A5

H

A5

H

A7

H

B19

H

B1

H

A3

H

B19

H

PE4

H

PE4

H

PE4

H

PE4

H

PE4

H

PE4

H

PE4

H

PE4

H

PE4

H

PE4

H

PE4

H

PE4

H

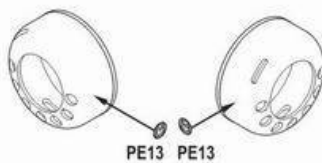

PE13 PE13

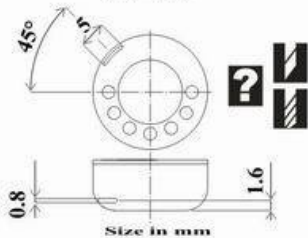

45°

0.8

1.6

Size in mm

2010102124

SH48099 - Morane Saulnier AI

4

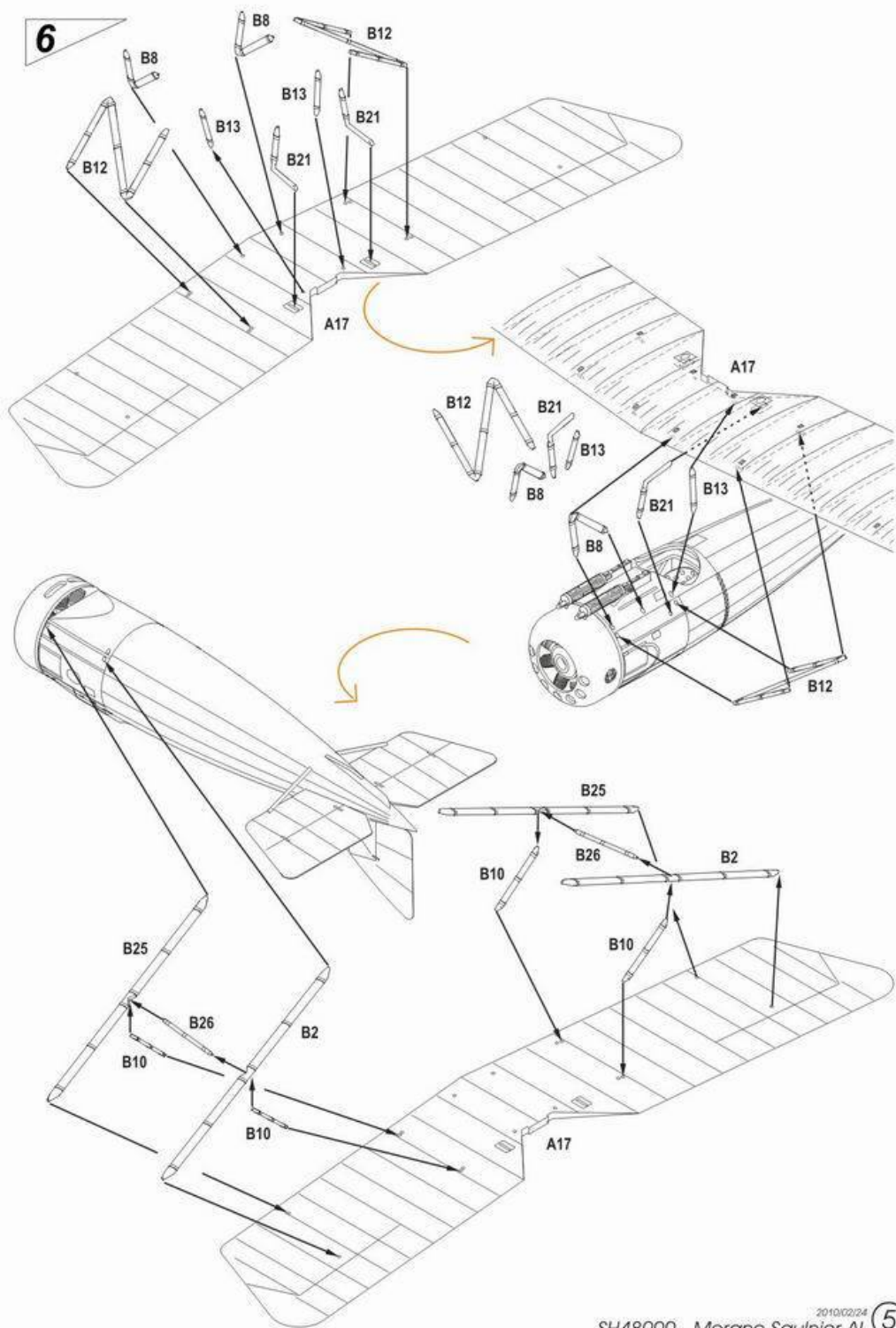
6

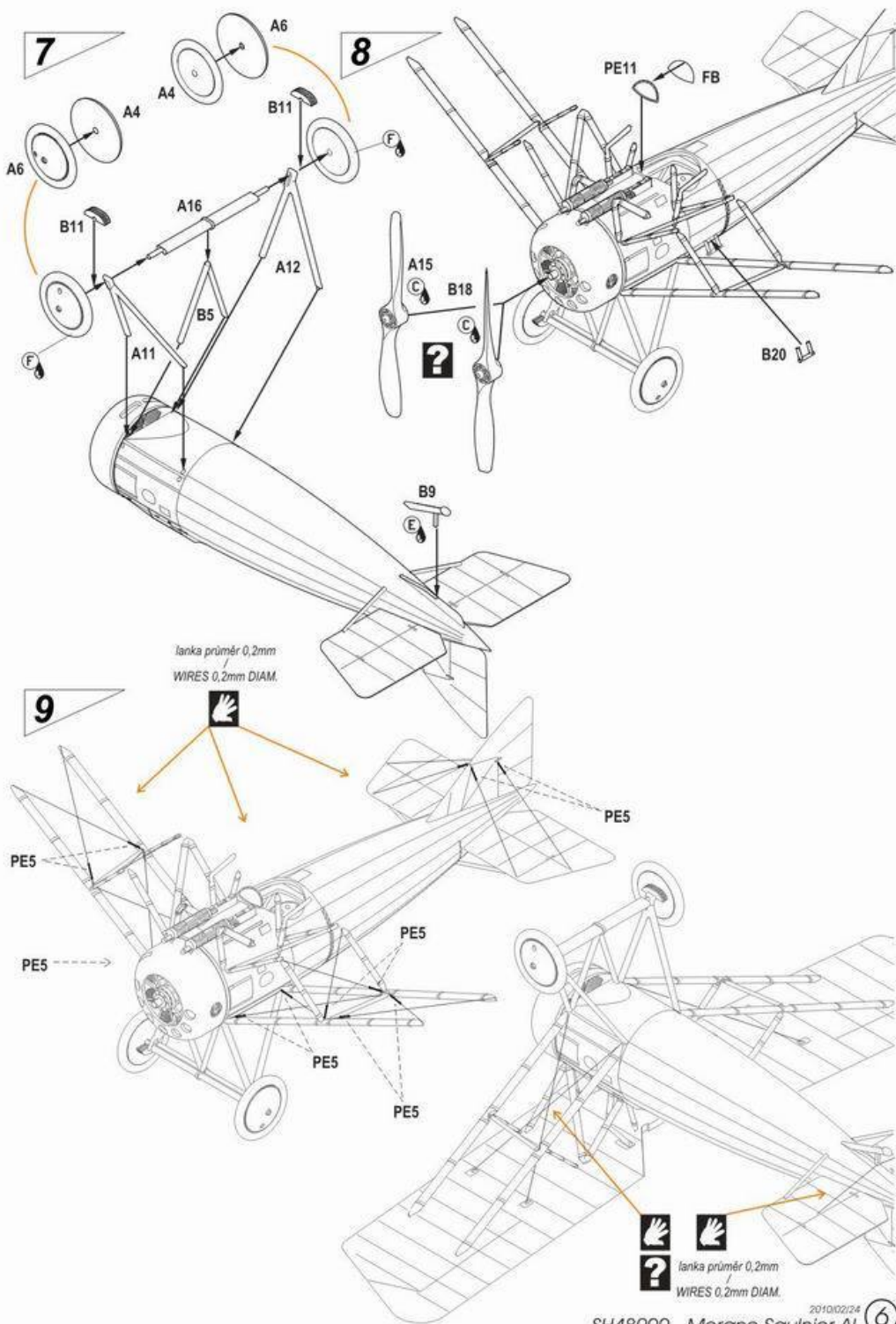

Morane-Saulnier AI, MS1591, červená „11“, Escadrille MSP 156, pilot Sgt. Walter J. Shaffer., únor 1918. Znak jednotky byl na letoun nastříkan v průběhu služby u MSP156, fotografie jej ukazují bez i se znakem.

Morane-Saulnier AI, MS1591, Red „11“, Escadrille MSP 156, pilot Sgt. Walter J. Shaffer, February 1918. The unit emblem was applied during its service with MSP156, although some photos show this machine both with and without this emblem.

CAM. A

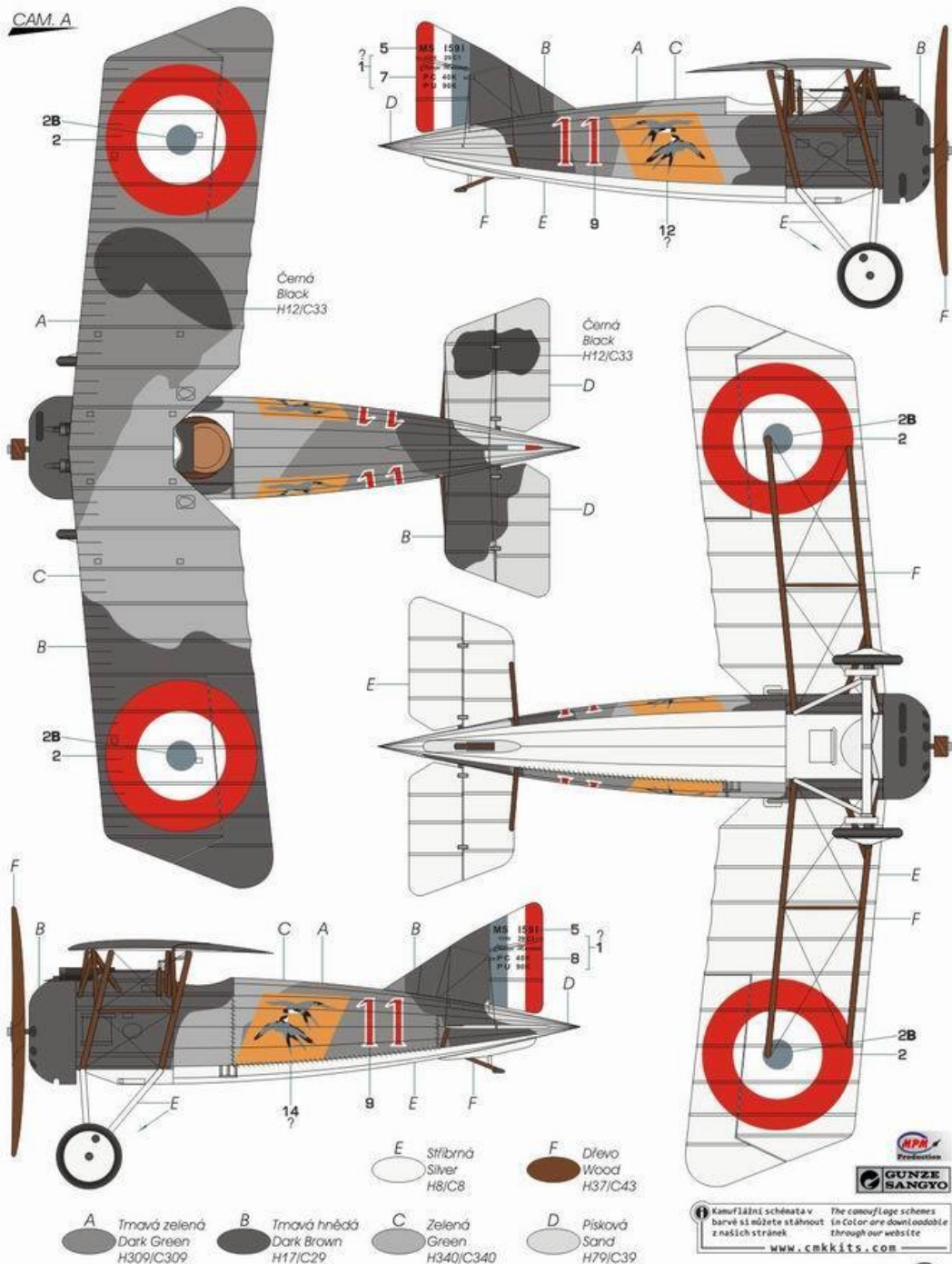

Černá
Black
H12/C33

Černá
Black
H12/C33

E
Stříbrná
Silver
H8/C8

F
Dřevo
Wood
H37/C43

A
Tmavá zelená
Dark Green
H309/C309

B
Tmavá hnědá
Dark Brown
H17/C29

C
Zelená
Green
H340/C340

D
Písková
Sand
H79/C39

! Kanulažní schémata v barvách si můžete stáhnout z našich stránek. The camouflage schemes in color are downloadable through our website. www.cmkkits.com

2010/02/24

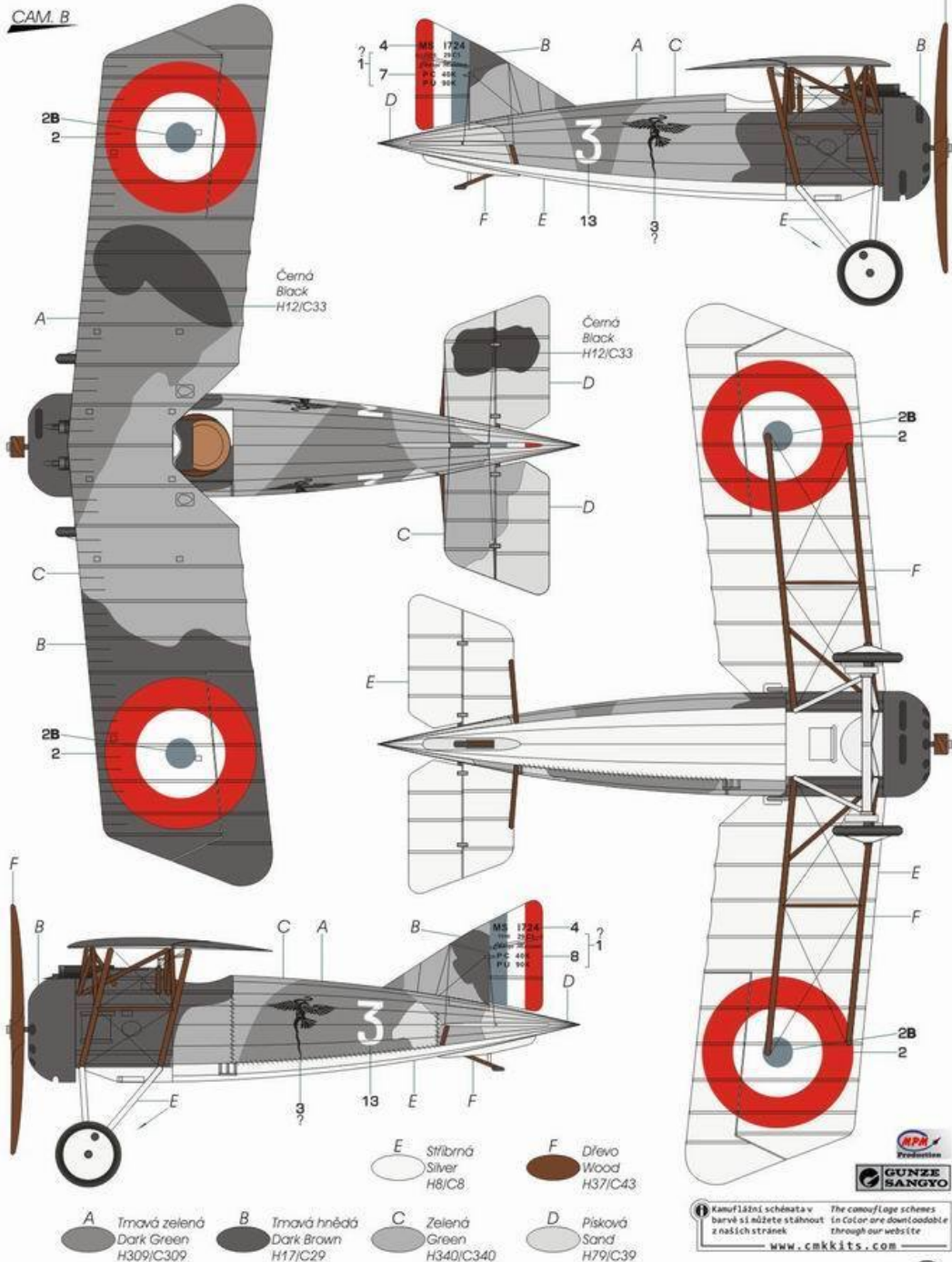

CAM. B

Černá
Black
H12/C33

Černá
Black
H12/C33

E Stříbrná
Silver
H8/C8

F Dřevo
Wood
H37/C43

A Tmavá zelená
Dark Green
H309/C309

B Tmavá hnědá
Dark Brown
H17/C29

C Zelená
Green
H340/C340

D Písková
Sand
H79/C39

Kamuflažní schémata v barvě si můžete stáhnout z našich stránek. The camouflage schemes in color are downloadable through our website. www.cmkkits.com

2010/02/24

CAM. C

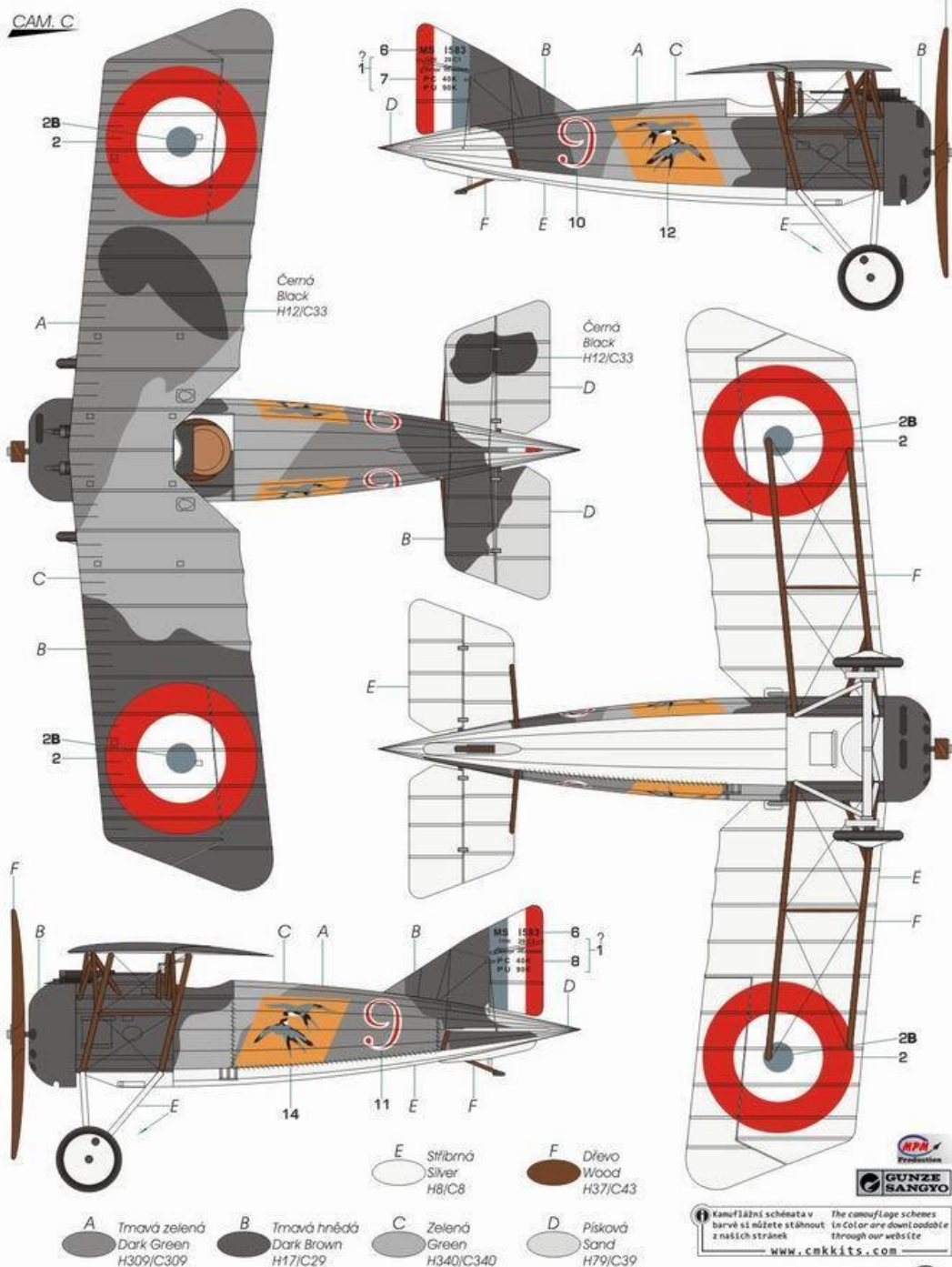

1 Kamuflážní schémata v barvě si můžete stáhnout z našich stránek. The camouflage schemes in color are downloadable through our website. www.cmkkits.com

2010/G2/24

Morane-Saulnier AI, MS1591, červená „11“, Escadrille MSP 156, pilot Sgt. Walter J. Shaffer., únor 1918. Znak jednotky byl na letoun nastříkán v průběhu služby u MSP156, fotografie jej ukazují bez i se znakem.

Morane-Saulnier AI, MS1591, Red „11“, Escadrille MSP 156, pilot Sgt. Walter J. Shaffer, February 1918. The unit emblem was applied during its service with MSP156, although some photos show this machine both with and without this emblem.

CAM. A

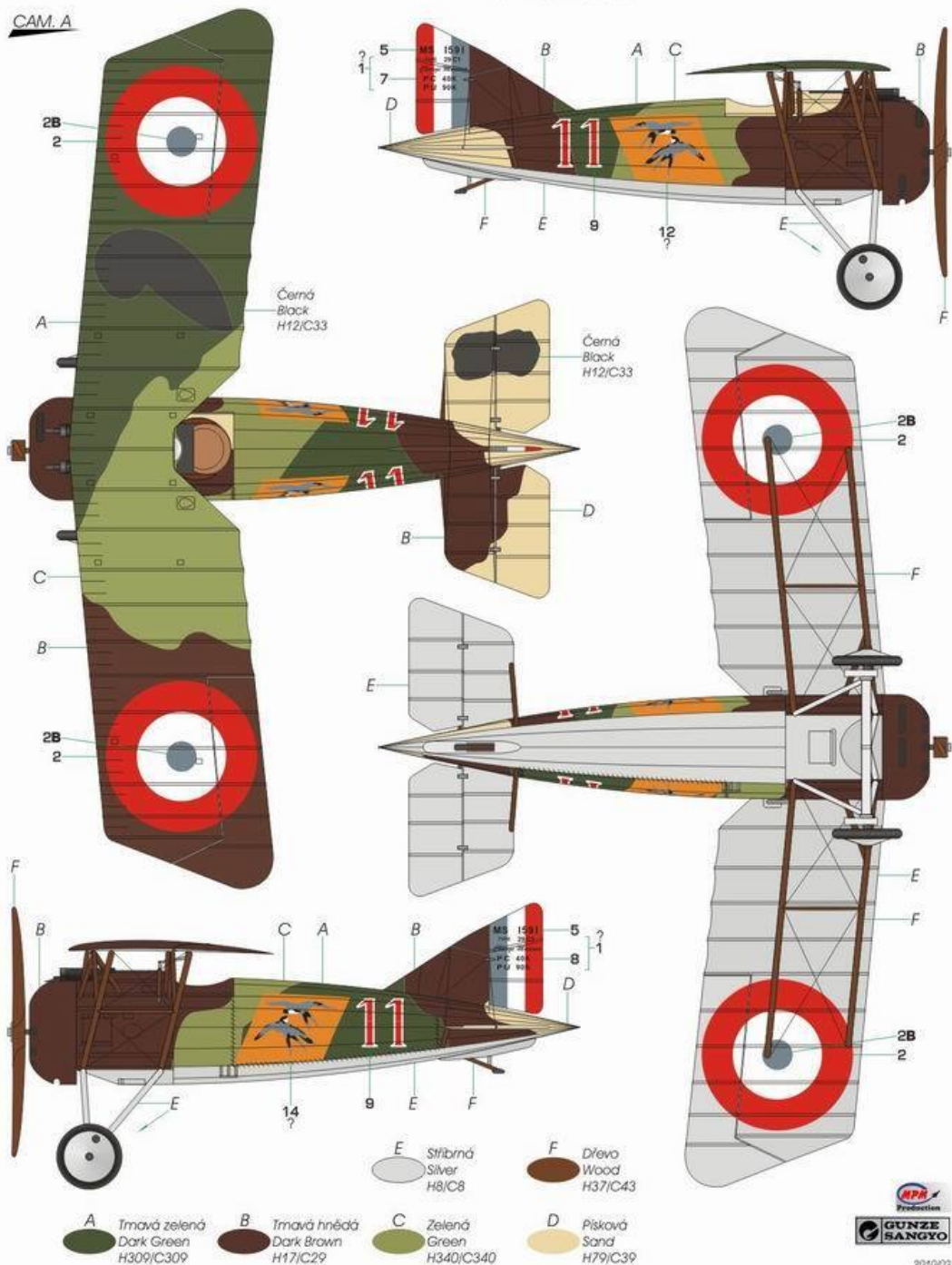

CAM. B

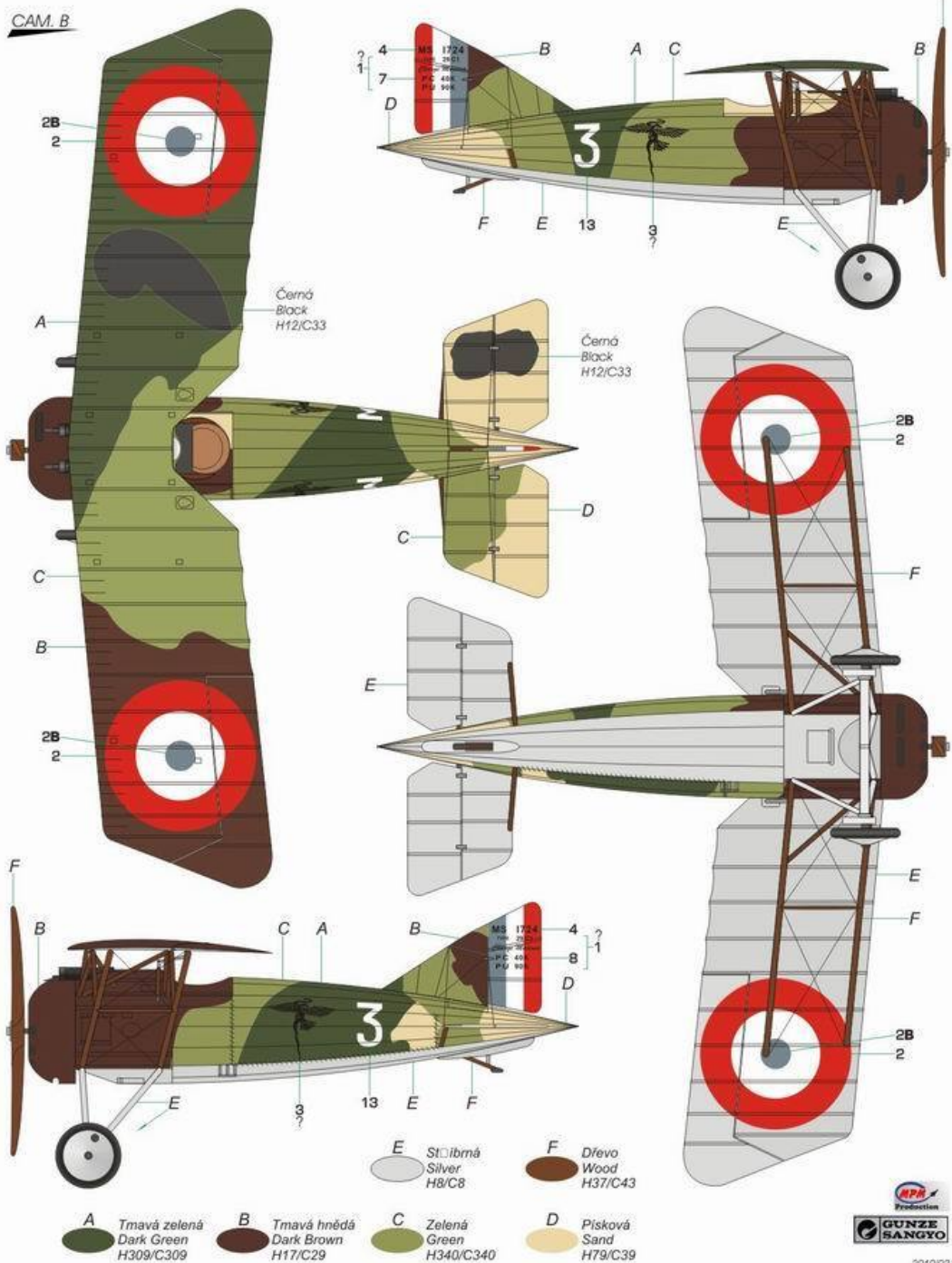

Morane-Saulnier AI, MS1591, červená „9“, Escadrille MSP 156, únor 1918. Znak jednotky byl na letoun nastříkán v průběhu služby u MSP156, fotografie jej ukazují bez i se známkem.

Morane-Saulnier AI, MS1591, Red „9“, Escadrille MSP 156, February 1918. The unit emblem was applied during its service with MSP156, although some photos show this machine both with and without this emblem.

CAM. C

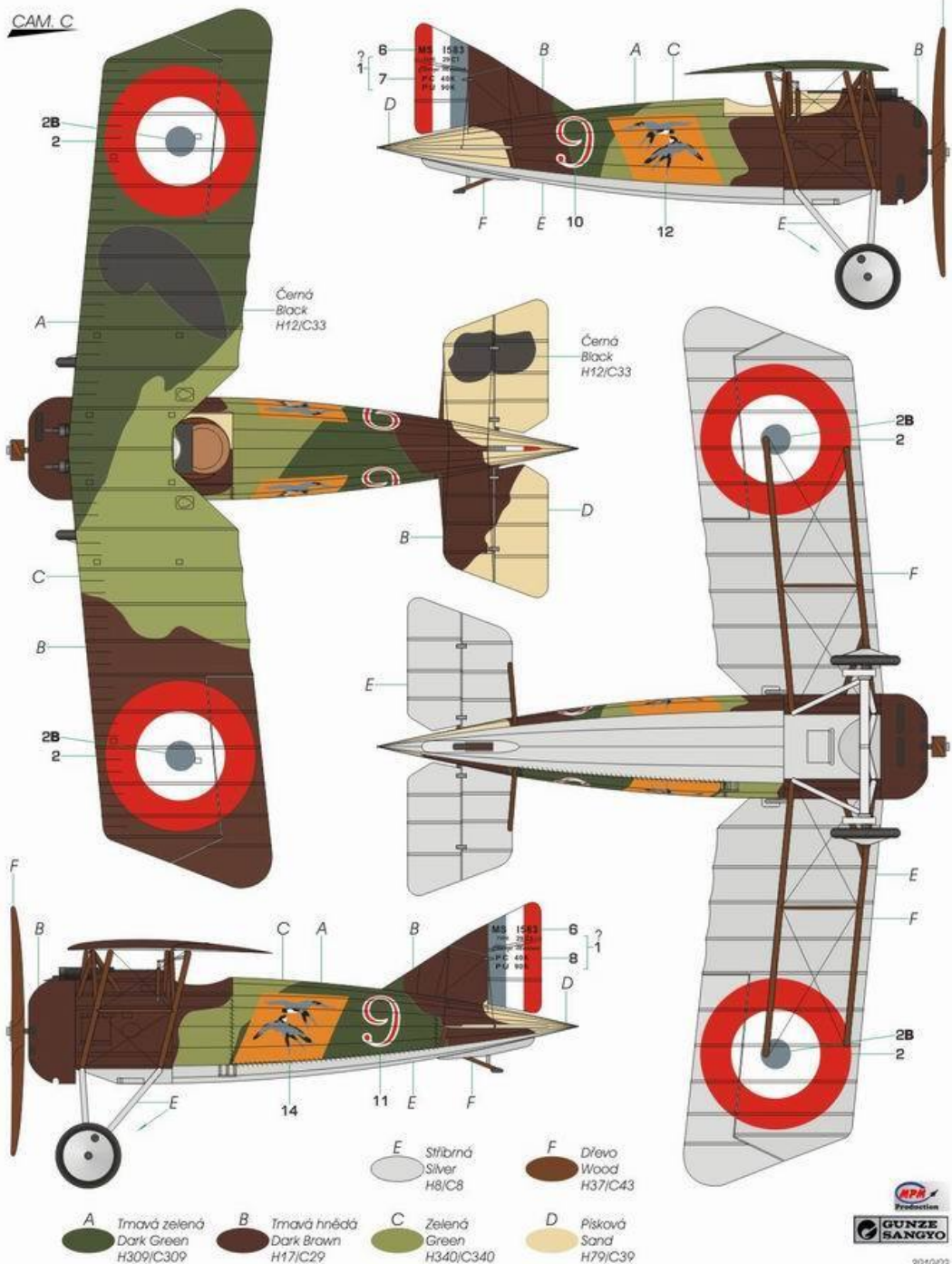

2010/02

SH48099 Morane Saulnier type AI