

TIGER I, Ausf.E

- Early version

(Basic set)

Zestaw podstawowy

1/16 scale update for Tamiya model

ABER[®]

16 002

WWW.ABER.NET.PL

Made in Poland © 2002

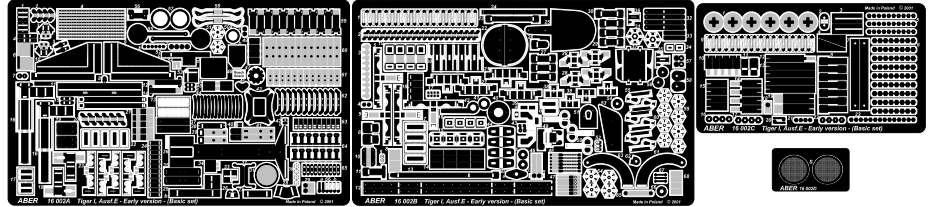

WARNING

Any unauthorized copying, producing and reproducing of ABER company products, or any part thereof, is strictly prohibited and any such action establishes liability for a civil action and may give rise to criminal prosecution.

OSTRZEŻENIE

Jakiegolwiek kopiowanie, produkowanie i reprodukcja wyrobów firmy ABER bez zezwolenia, w całości lub części jest surowo zabronione. Powyższe działania powodują powstanie odpowiedzialności cywilnej oraz mogą spowodować wszczęcie postępowania karnego.

C9

Solder together (złutować razem)

B1

Solder together (złutować razem)

B2&A20

Metal rod \varnothing 0,5mm (metalowy pręt)

Plastic or metal plate (pasek z tworzywa lub metalu)

Fold (zagiąć)

Solder (złutować)

\varnothing 0,5mm

OPTIONAL

Solder together (złutować razem)

A60

Wire (drut) \varnothing 0,4 mm

A61

A64

Wire (drut) \varnothing 0,3 mm

A59

A44

Wire (drut) \varnothing 0,3 mm

A62

Wire (drut) \varnothing 0,4 mm

A3

Wire (drut) \varnothing 0,6 mm

A5

C1

A24

Wire (drut) \varnothing 0,4 mm

C5

Cable (lina) \varnothing 1,2 mm

Wire (drut) \varnothing 0,3 mm

A37

Wire (drut) \varnothing 1,2 mm

C11

Wire (drut) \varnothing 0,5 mm

C23

C8

A4

Wire (drut) \varnothing 0,4 mm

A22

Wire (drut)

A23

B1/C9

Wire (drut)

A21

C10

We advise that better method to join metal to metal is soldering. Use ABER soldering solution AF20 (doradzamy łączenie części metalowych za pomocą lutownia. Zastosuj nasz topnik AF20)

Please note that, for purpose of improvement ABER sets designs are subjects to change without notice. Proszę mieć na uwadze fakt, że zestawy ABER mogą ulec zmianie ze względu na ulepszenia, bez powiadomienia.

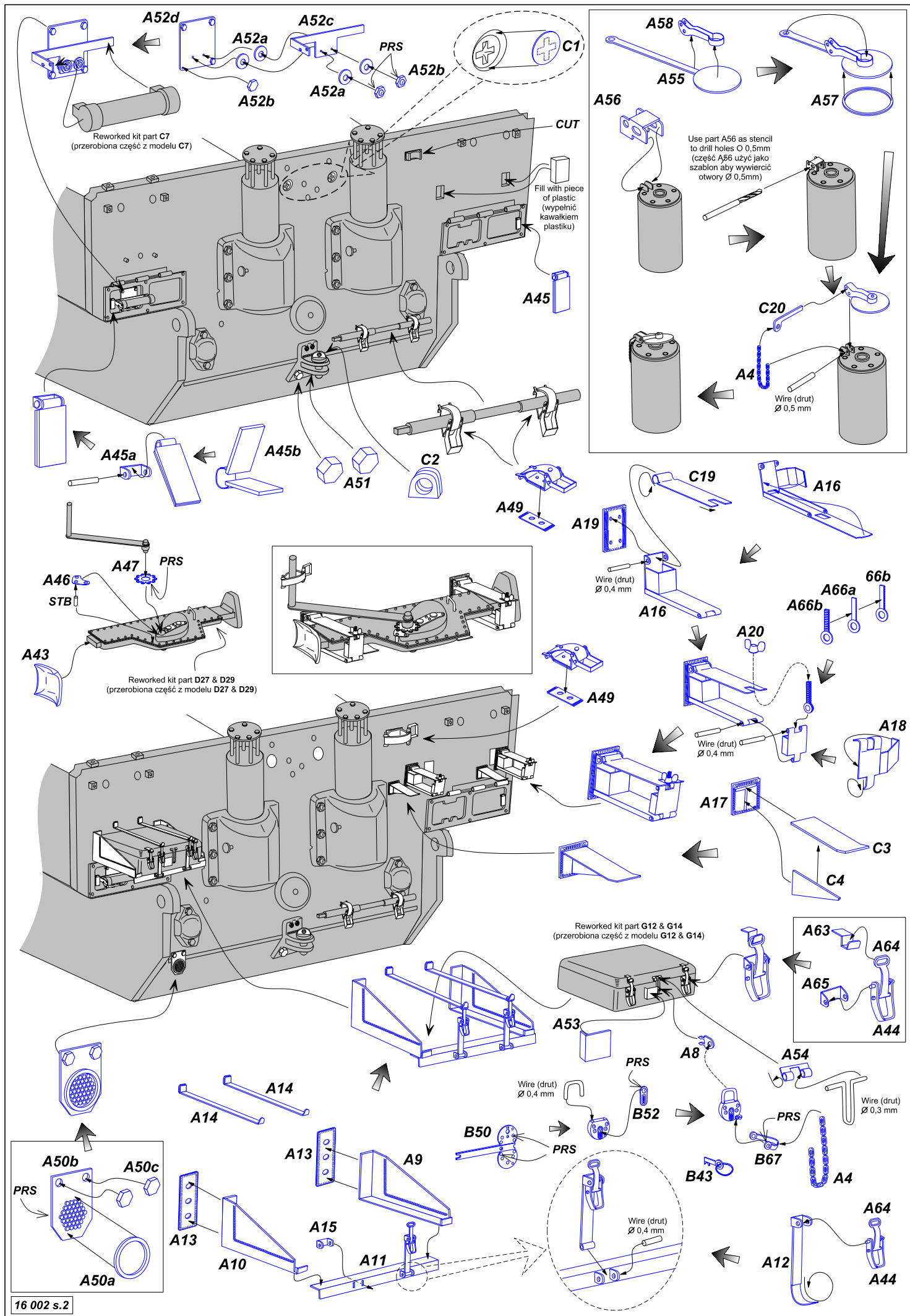

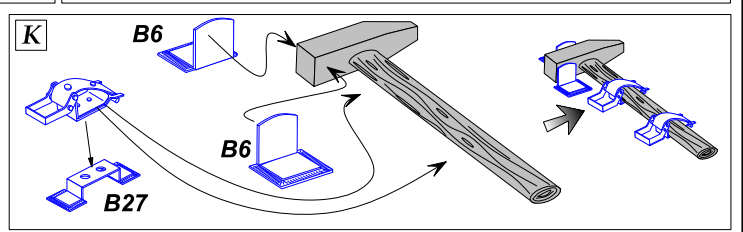
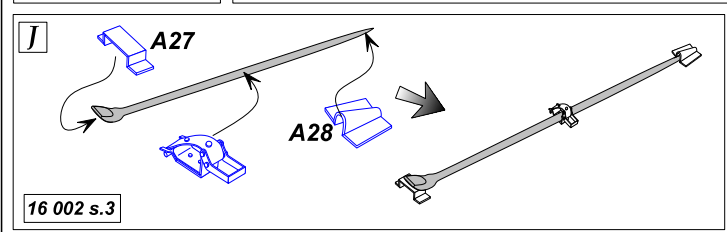
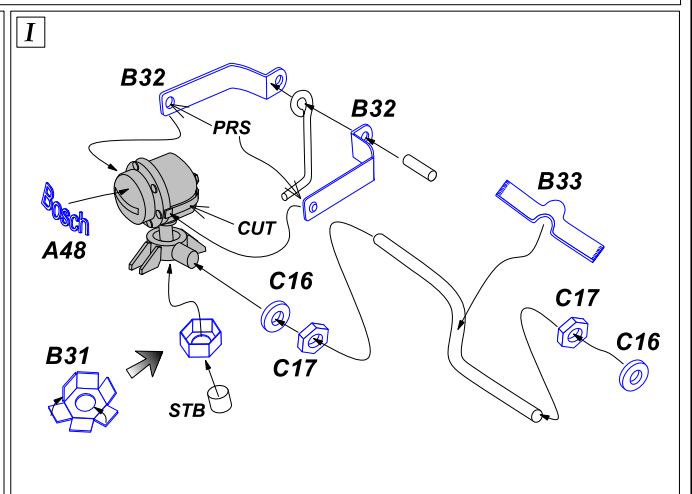
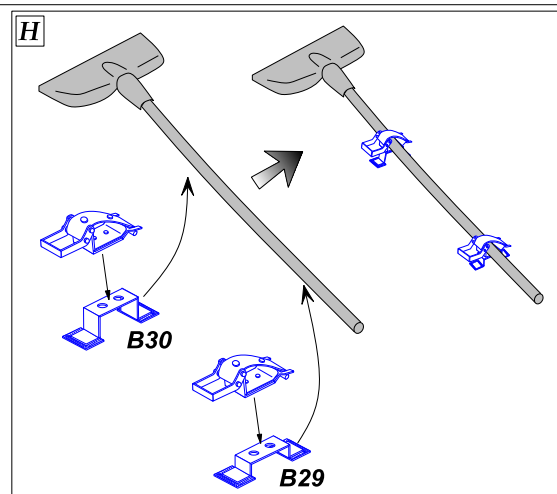
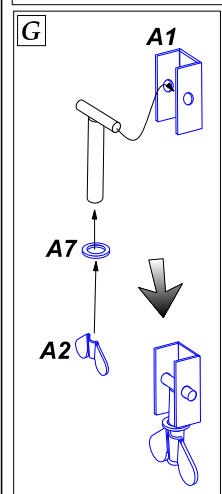
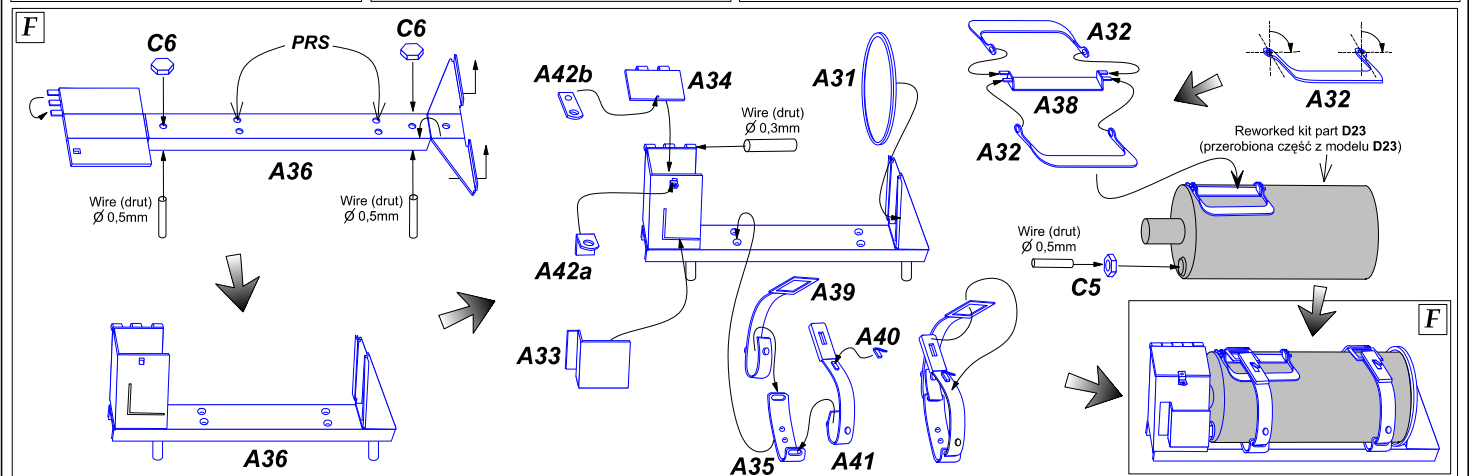
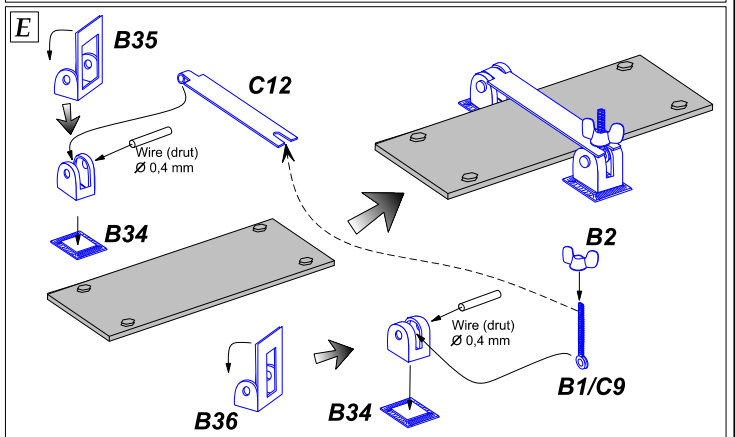
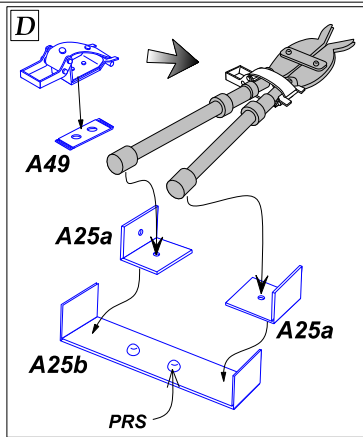
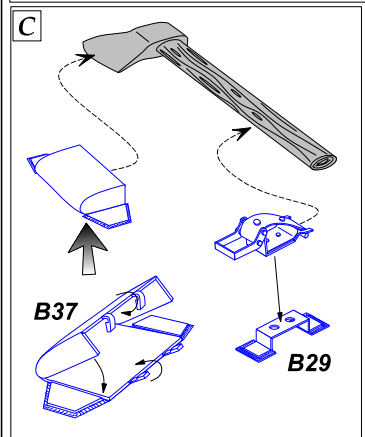
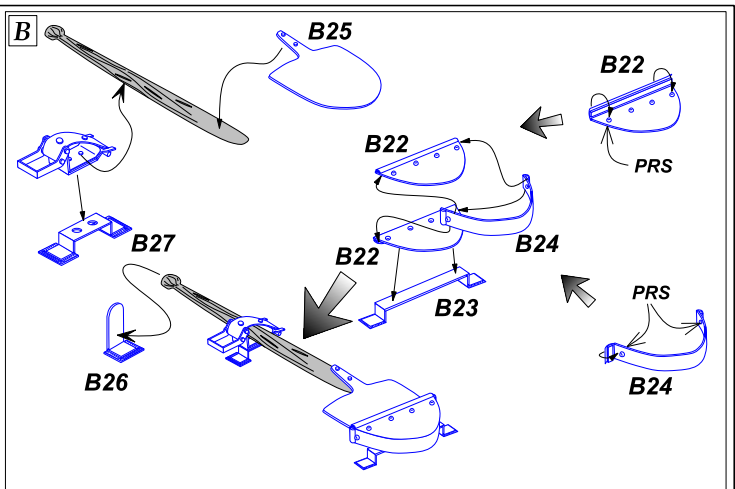
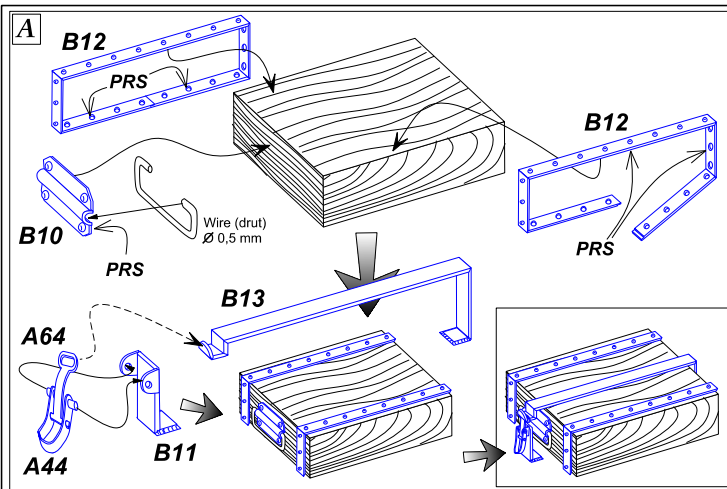

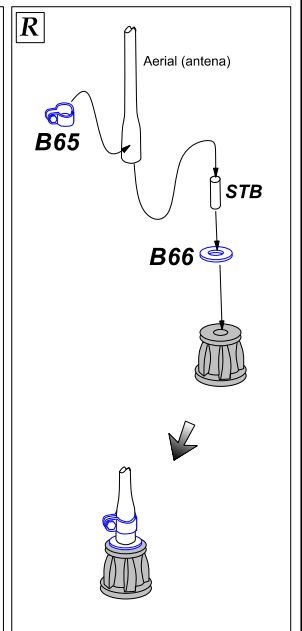
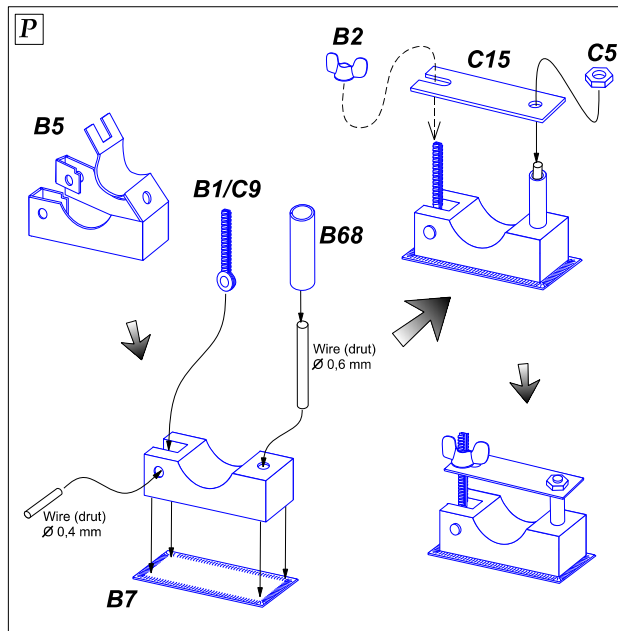
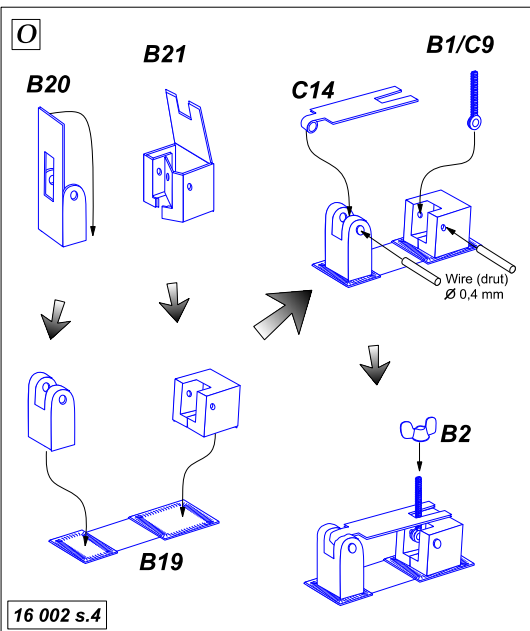
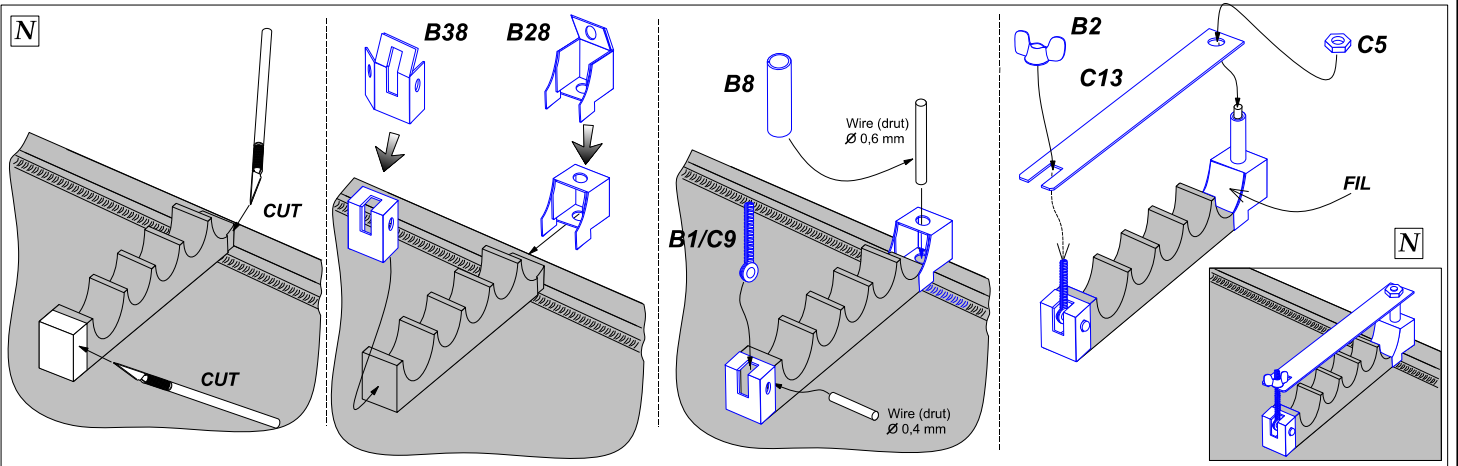
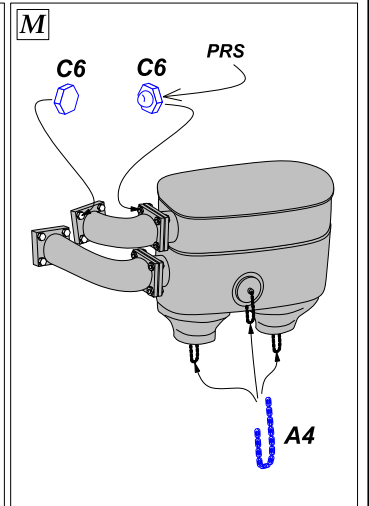
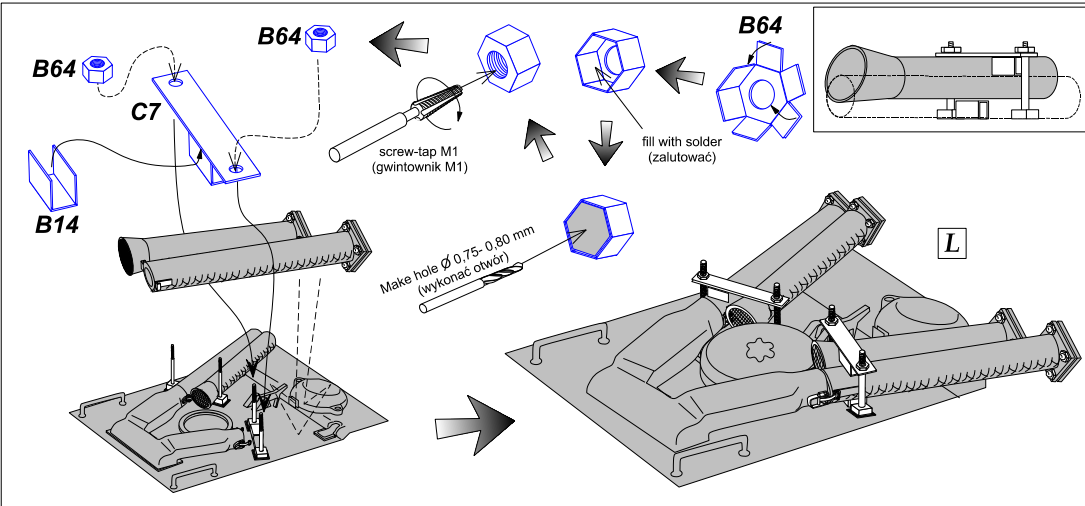
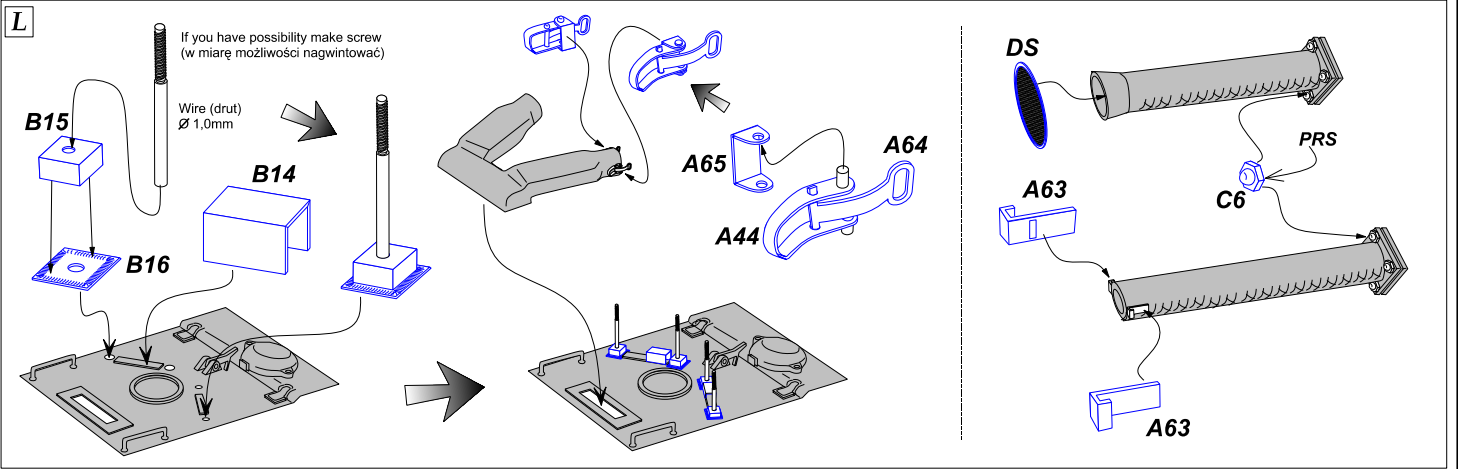

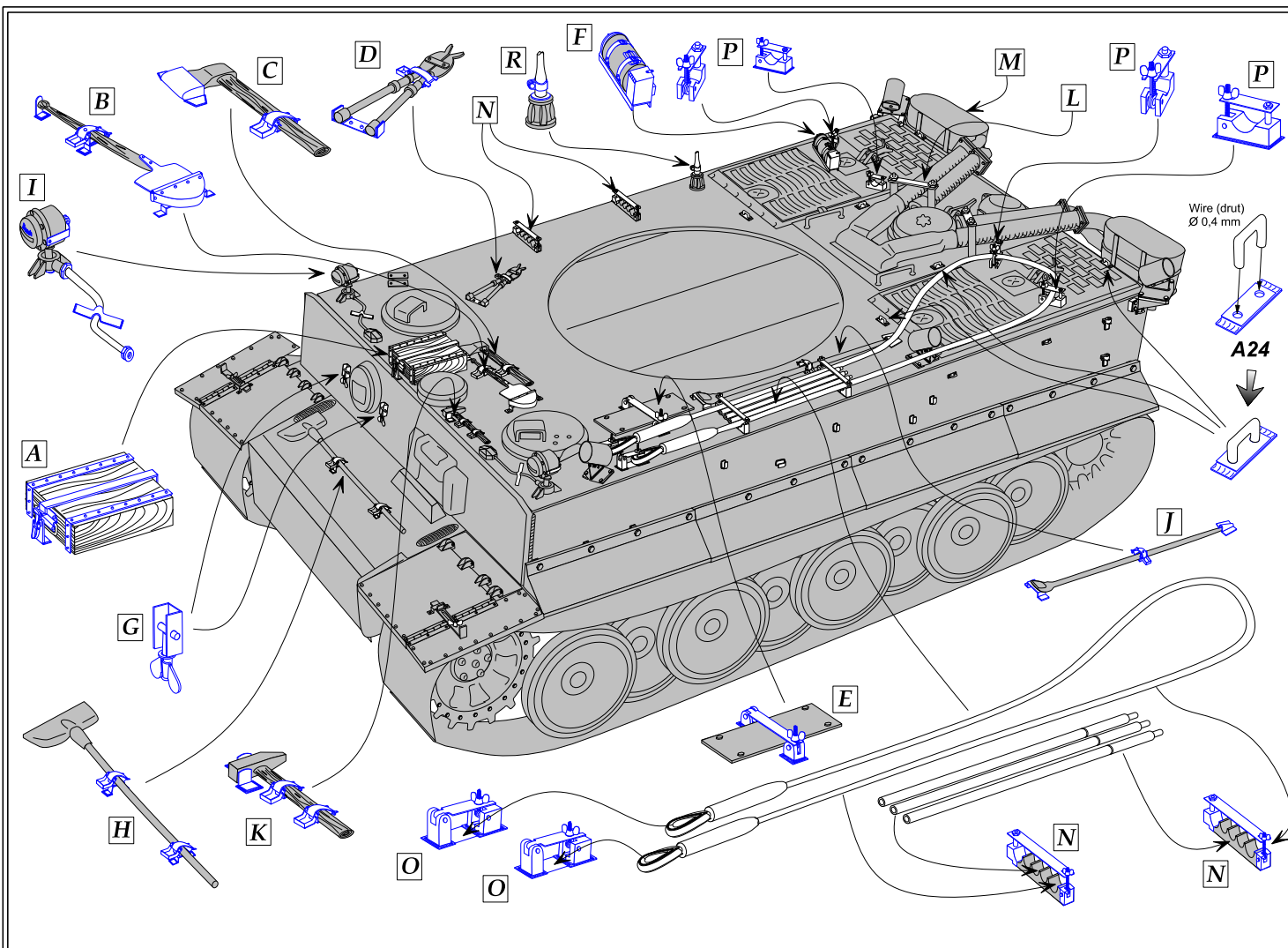

Use part B51 as stencil to mark holes
(zastosować część B51 jako szablon
do zaznaczenia otworów)

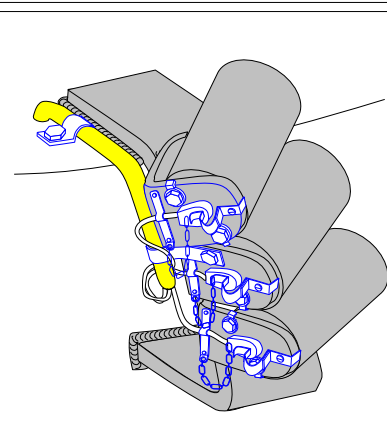
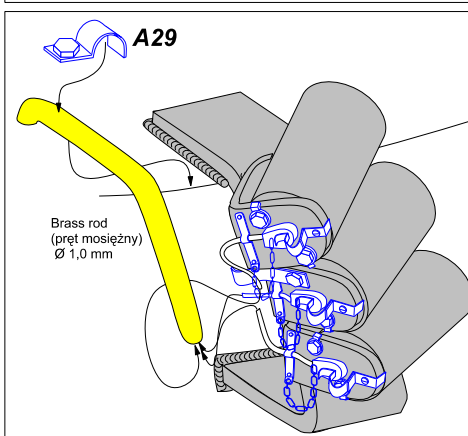
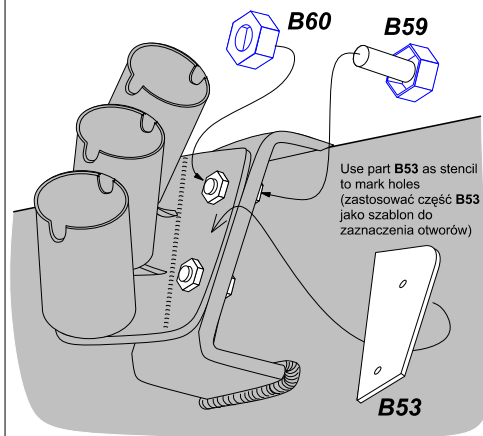
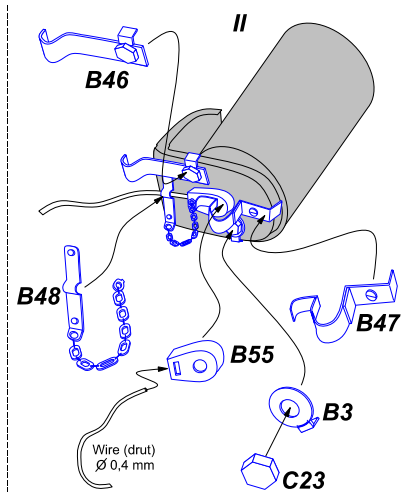
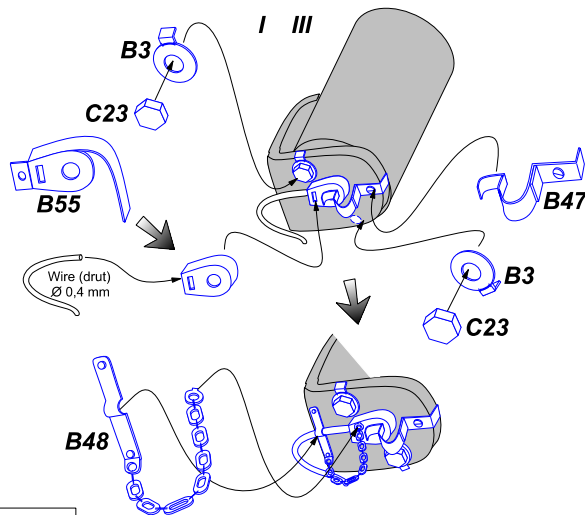
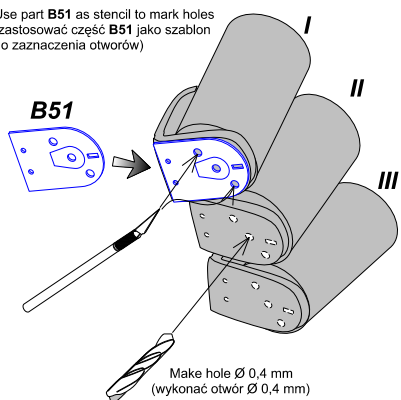

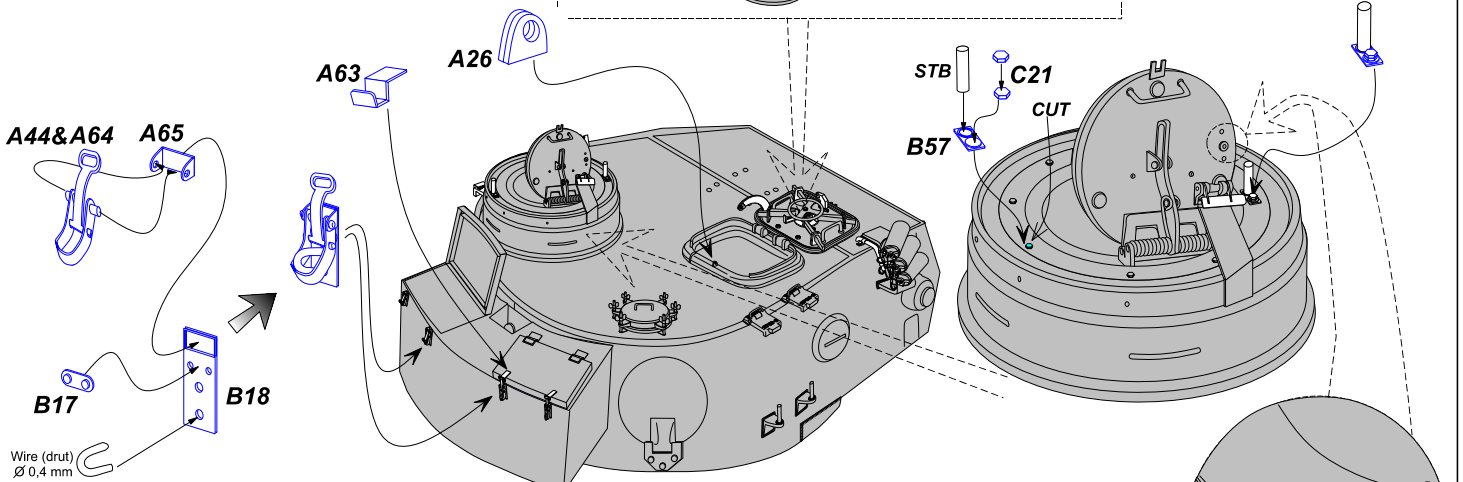
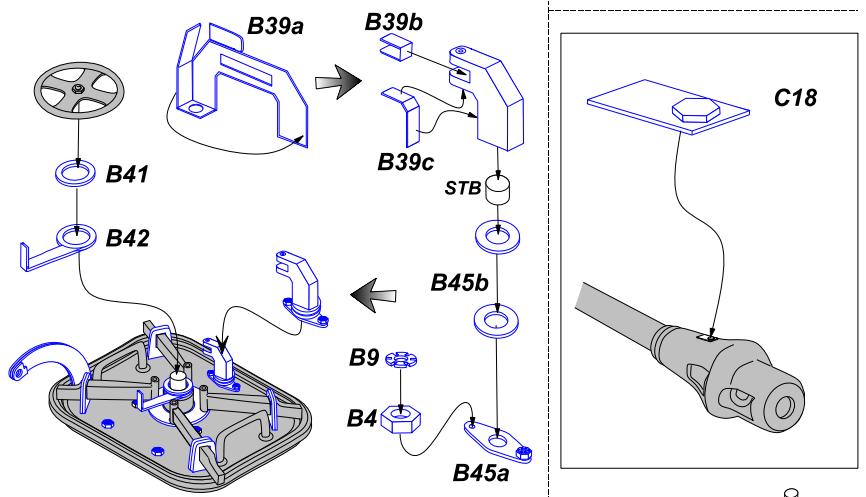
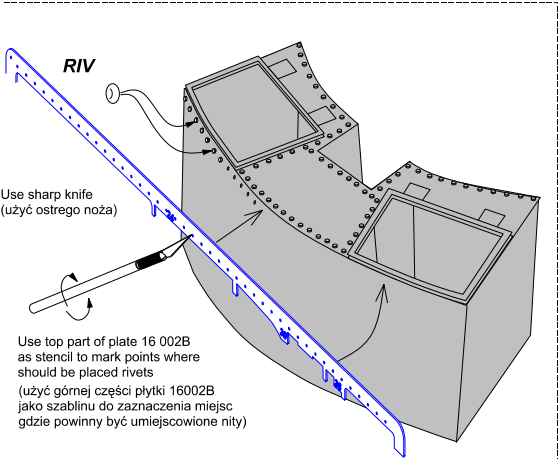
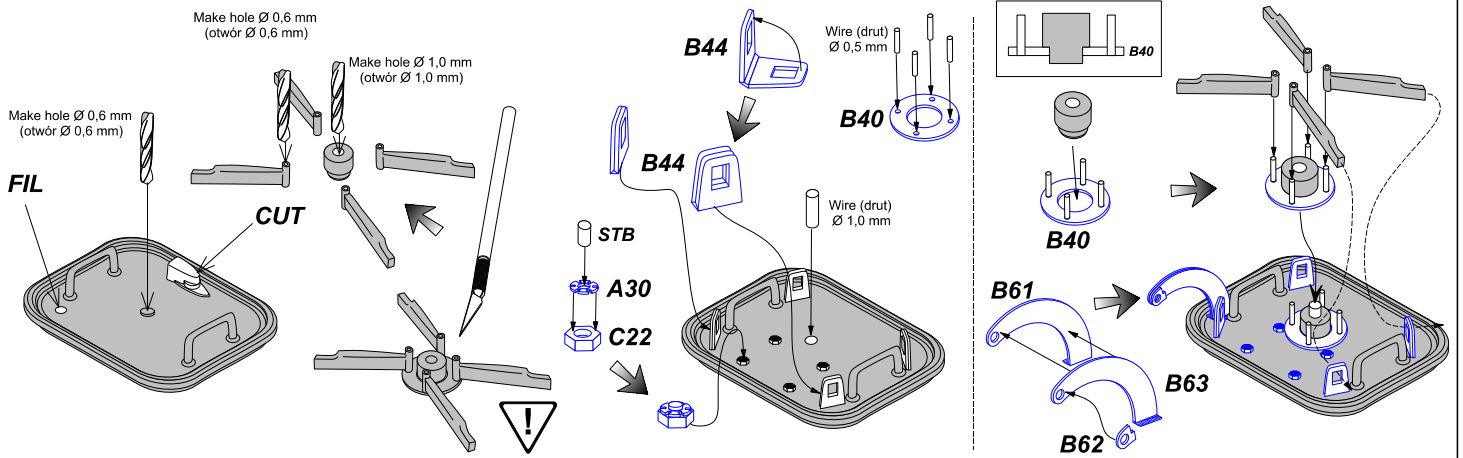

- Separately sold (oddzielnie w sprzedaży):
- 16 003 -TIGER I, Ausf.E - Grilles (Early vesion)
 - 16 004 -Front fenders Tiger I, Ausf.E (Early/Late vesion)
 - 16 005 -Rear fenders Tiger I, Ausf.E (Early vesion)
 - 16 006 -Side fenders Tiger I, Ausf.E (Early/Late vesion)
 - 16 007 -Exhaust covers Tiger I, Ausf.E (Early/Late vesion)
 - 16 008 -TIGER I, Ausf.E - Early vesion (Additional set)
 - 16 009 -Commander's cupola interior for Tiger I, Ausf.E early vesion
 - 16 010 -Driver's hatch details for Tiger I, Ausf.E (for all vesions)
 - 16 012 8.8 cm Tiger I A/T Ammo with box
 - 16 032 German 2 meter standard Antenna
 - 16 L-03 - German barrel for tank machine gun MG 34 with Panzermantel

