

NICARAGUAN FAN 306; AIRCRAFT IS BARE METAL OVERALL WITH ORANGE INTAKE WARNINGS, DIVE BRAKES, AND TURBINE WARNING STRIPE, TIP TANKS ARE FLAT BLACK ON THE INSIDE, GUN PORTS ARE OUTLINED IN ORANGE.

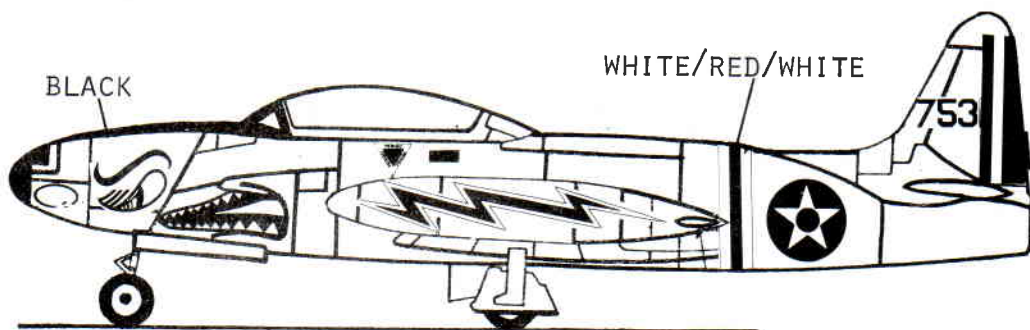

GUATAMALA FAG 753; AT LEAST 5 T-33'S WERE ACQUIRED IN 1971, THESE AIRCRAFT EQUIP ESQUADRON DE CAZA-BOMBARDEO, AIRCRAFT IS OVERALL DARK GRAY FSC#36231

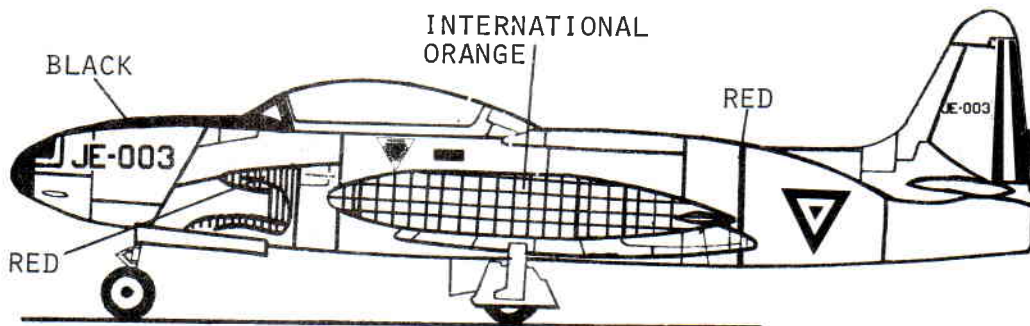

MEXICO JE-003; AT LEAST 15 T33'S ARE OPERATED BY 202 SQUADRON OF THE MEXICAN AIR FORCE.

THERE HAVE BEEN MANY PROGRESSIVE CHANGES IN THE COLOR SCHEMES OF MEXICAN T33'S. THE AIRCRAFT WERE DELIVERED BARE METAL OVERALL WITH THE MARKINGS AS SHOWN;

1965; INTAKES WERE PAINTED RED

1961; TIP TANKS PAINTED OUTER HALF INTERNATIONAL ORANGE, INNER HALF REMAINED BLACK.

1972; VERTICAL STABILIZER MINUS RUDDER AREA PAINTED INTERNATIONAL ORANGE.

1977; AIRCRAFT PAINTED LT. GULL GRAY FSC#16440 OVERALL, ALL MARKINGS REMAIN THE SAME

NICARAGUAN

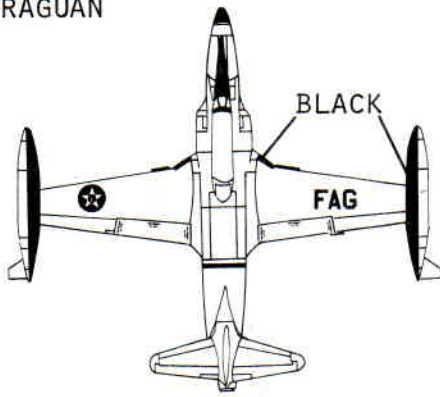

TOP

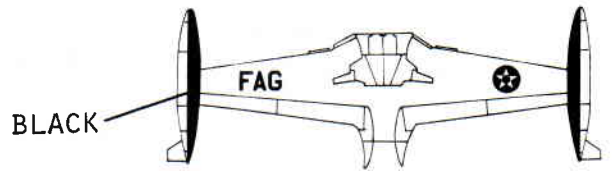

BOTTOM

GUATAMALA

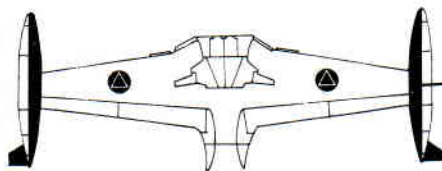

BOTTOM

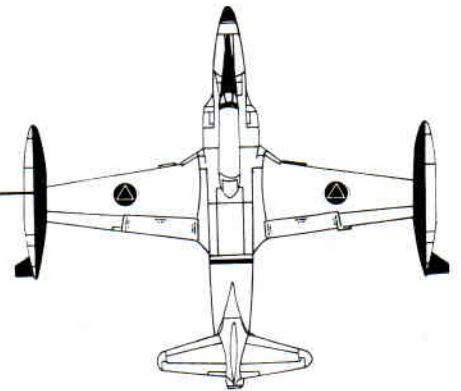

TOP

MEXICO

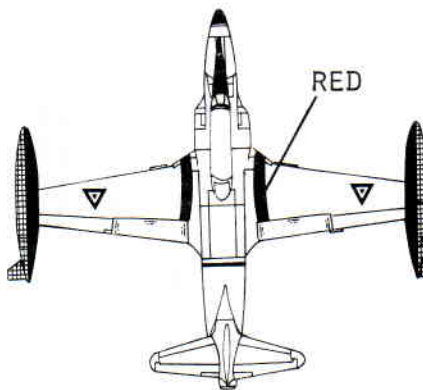

TOP

RESEARCH BY
NICK WATERS

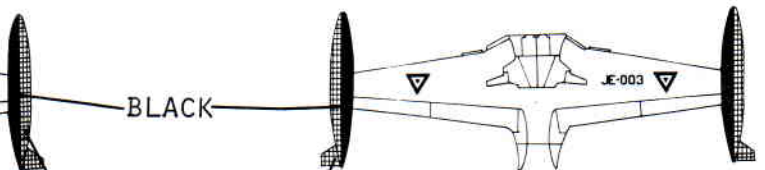

BOTTOM

INTERNATIONAL ORANGE

DETAILS OF MEXICAN FIN
MARKINGS 1972. ALL MARKINGS
REMAIN THE SAME AS IN
MAIN DRAWING.

