



### SAAB JA37 Viggen

Saab 37 Viggen took to the skies for the first time on February 8th 1967, in the hands of test pilot Erik Dahlström.

The first studies that lead to the Viggen were conducted as early as 1952. The Swedish Air Force (Flygvapnet) needed a replacement for Lansen and Draken, that at the time had yet to enter service. The aim was to produce a multirole fighter able to replace all different aircraft types in the inventory.

The Swedish strategy was at the time based on dispersion of the aircraft and this meant that the new fighter had to be able to take off and land on 800m long strips of roads. Combined with requirements for high speed and good performance at all altitudes meant that Saab had to choose an unconventional design. A large delta wing provided good performance at high speeds and a canard wing provided positive lift which ensured good low speed handling. In order to ensure short landing distances, the aircraft was equipped with a thrust reverser, enabling the Viggen to reverse on the ground.

The fighter version of the Viggen, JA37, differed significantly from the earlier versions. In fact, it was considered to be half a generation younger. Mods included a fixed 30mm Oerlikon automatic cannon, new pulse Doppler radar, new avionics, the fin from the Sk 37 trainer version and completely new electronics.

JA37 had a more powerful engine, the RM8B, giving 12750kp in full reheat. The new engine was longer and required the fuselage of the fighter version to be lengthened.

The first JA37 was delivered to F13 wing in Norrköping in 1979. Production ended in 1990 after 149 airframes. At that time, JA37 served with F4 Östersund, F13 Norrköping, F16 Uppsala, F17 Ronneby and F21 Luleå. The JA37 Viggen served in Flygvapnet until 2004.

Two of the aircraft on our decal sheet are preserved: 37338 at Vidsel and 37449 at the Air Force Museum in Linköping. Many other JA37s are preserved at museums in Europe. However, only 37415 and 37449 are airworthy but due to the advanced electronics it's highly unlikely that any JA37 will ever fly again.

For more references and a complete production list of all JA37's, visit [www.tarangus.se](http://www.tarangus.se).

SAAB JA37 Viggen

1/72  
scale

**PLASTIC PARTS**

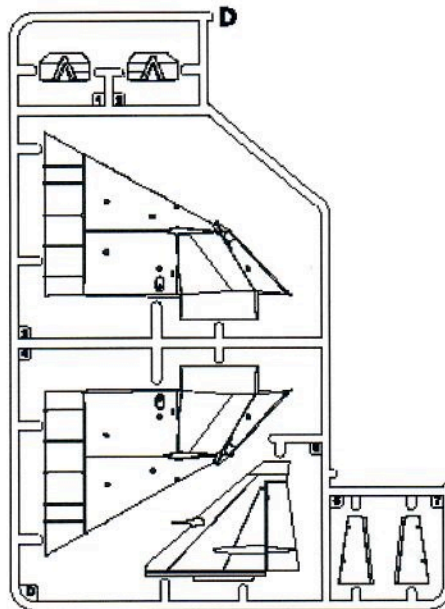
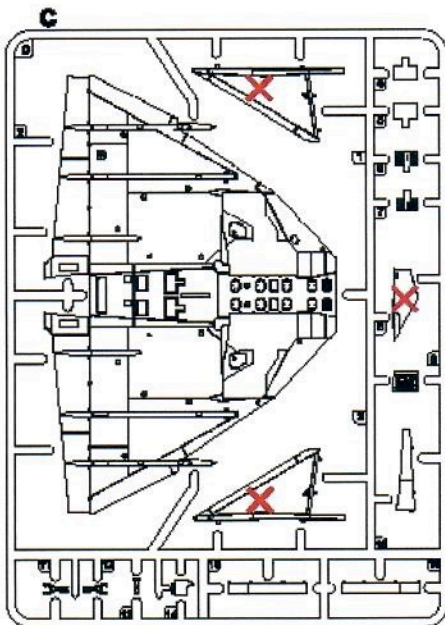
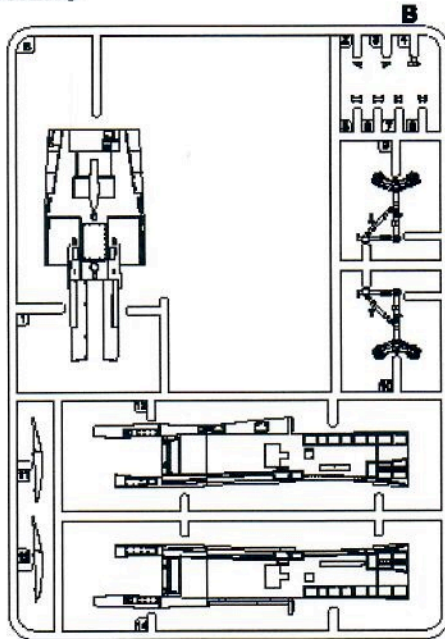
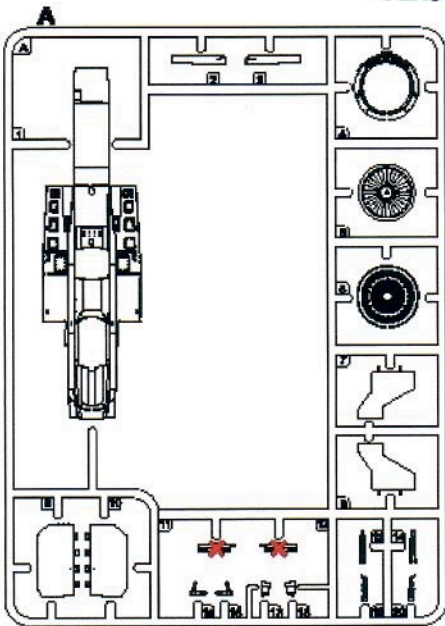

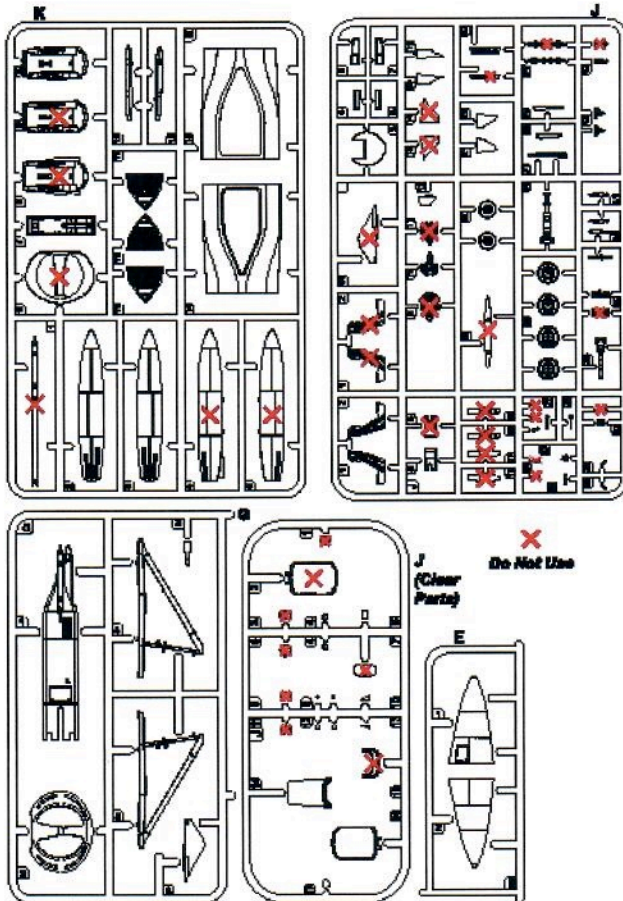

#### GENERAL INFORMATION

We suggest that you rinse the plastic parts with soap and water, to remove possible remains of release agents.

Plastic model glue and some model paints can be unhealthy to inhale. Make sure you have good ventilation in the building area.

This kit is not recommended for children under the age of 14 - if not accompanied by an assisting adult.

#### PAINTING

A separate colour print with camo patterns and stenciling instructions is enclosed with this kit.

The splinter camo was applied in a specified pattern so all Viggen were almost identical in appearance - at least when new! Some differences have been documented so check your references when building other decal versions than in the model kit. Aircraft colours faded and got weathered over the years.

A way to save some work when doing the splinter camo is using the camo paint mask set MMK7271 from [www.maestromodels.com](http://www.maestromodels.com). They also have a lot of extra equipment on and around the Viggen aircraft and other Swedish subjects.

#### Interior colours (Gunze Sangyo)

Cockpit interior grey H-308  
 Seat cushions green H-319  
 Pedals aluminum with black rubber details  
 Rudder stick handle black.

Wheel wells are different tones of natural metal.

SEE OUR WEB SITE FOR DETAIL PHOTOS!

[www.tarangus.com](http://www.tarangus.com)

#### HINTS AND TIPS

An extremely useful book about Viggen is available:

**Nordic Airpower #5 SAAB 37**

**Viggen, The ultimate portfolio.**

It is probably the best Viggen book ever released.

The book lacks only one ingredient that the modeller looks for, namely close-up detail photos. You find more of that in:

**Squadron Signal: Viggen Walk Around.**

On Facebook, you can find a group all devoted to Viggen. The name is Saab 37 Viggen and had over 10.000 members in October 2018.

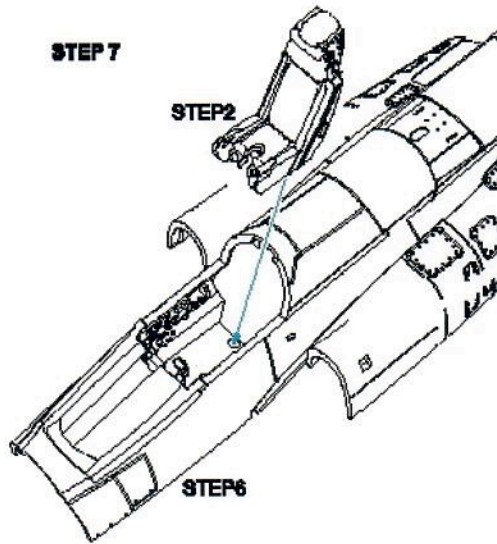
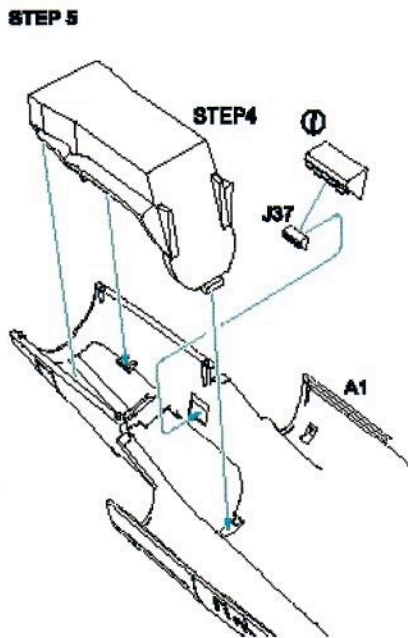
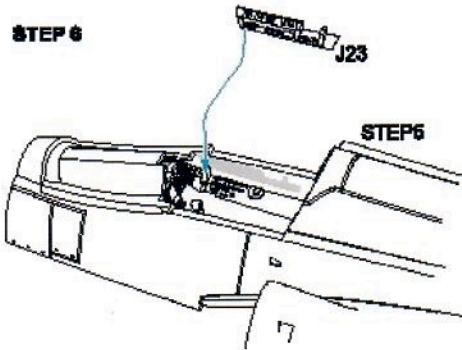
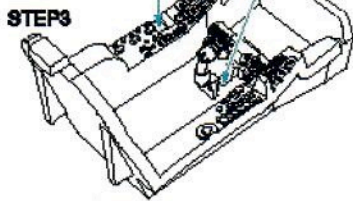
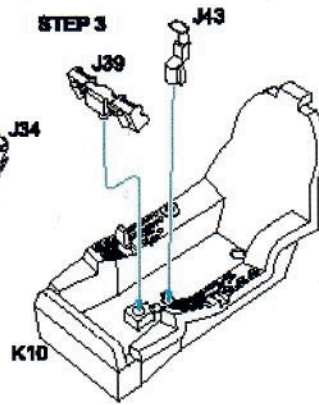
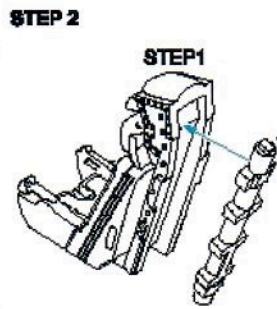

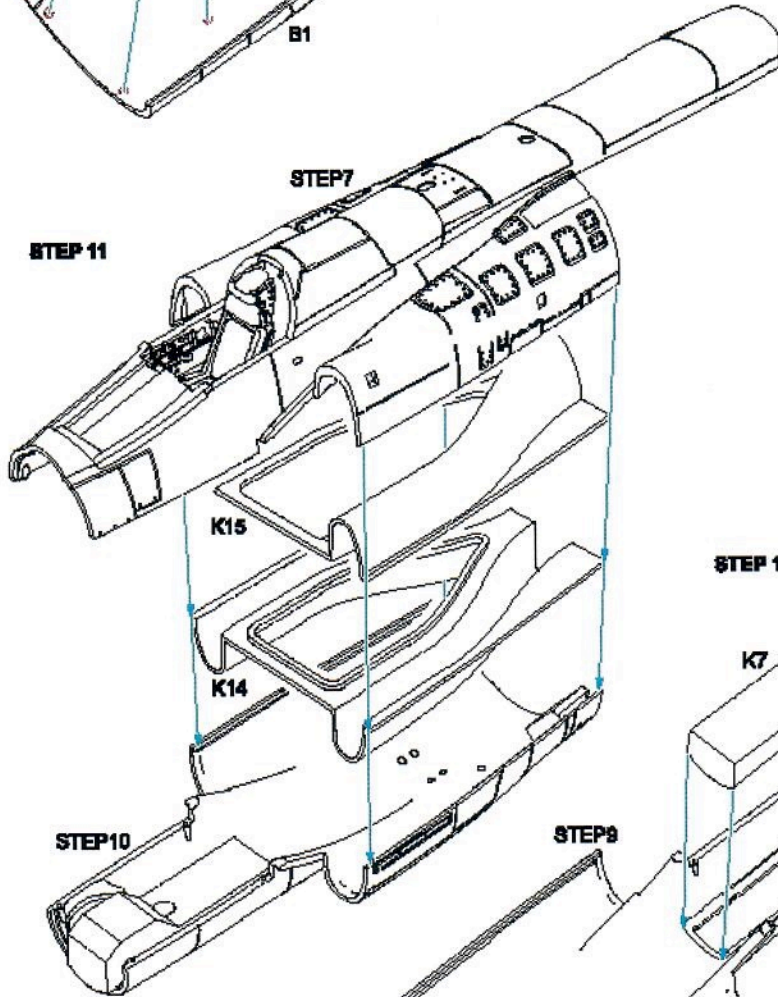
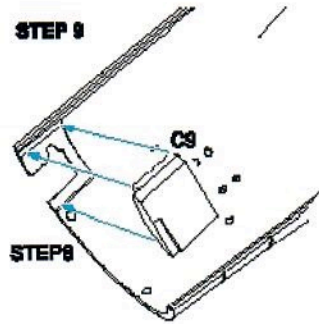
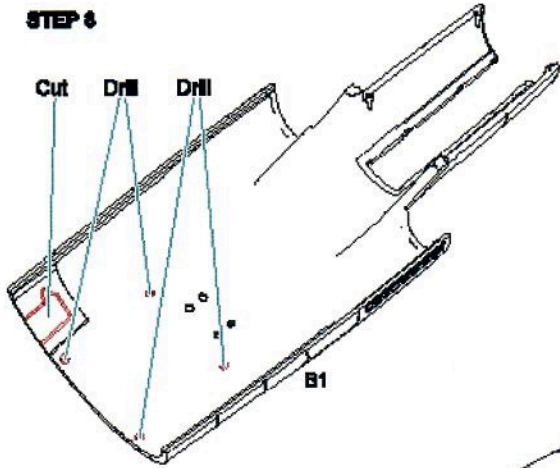

**STEP 12**

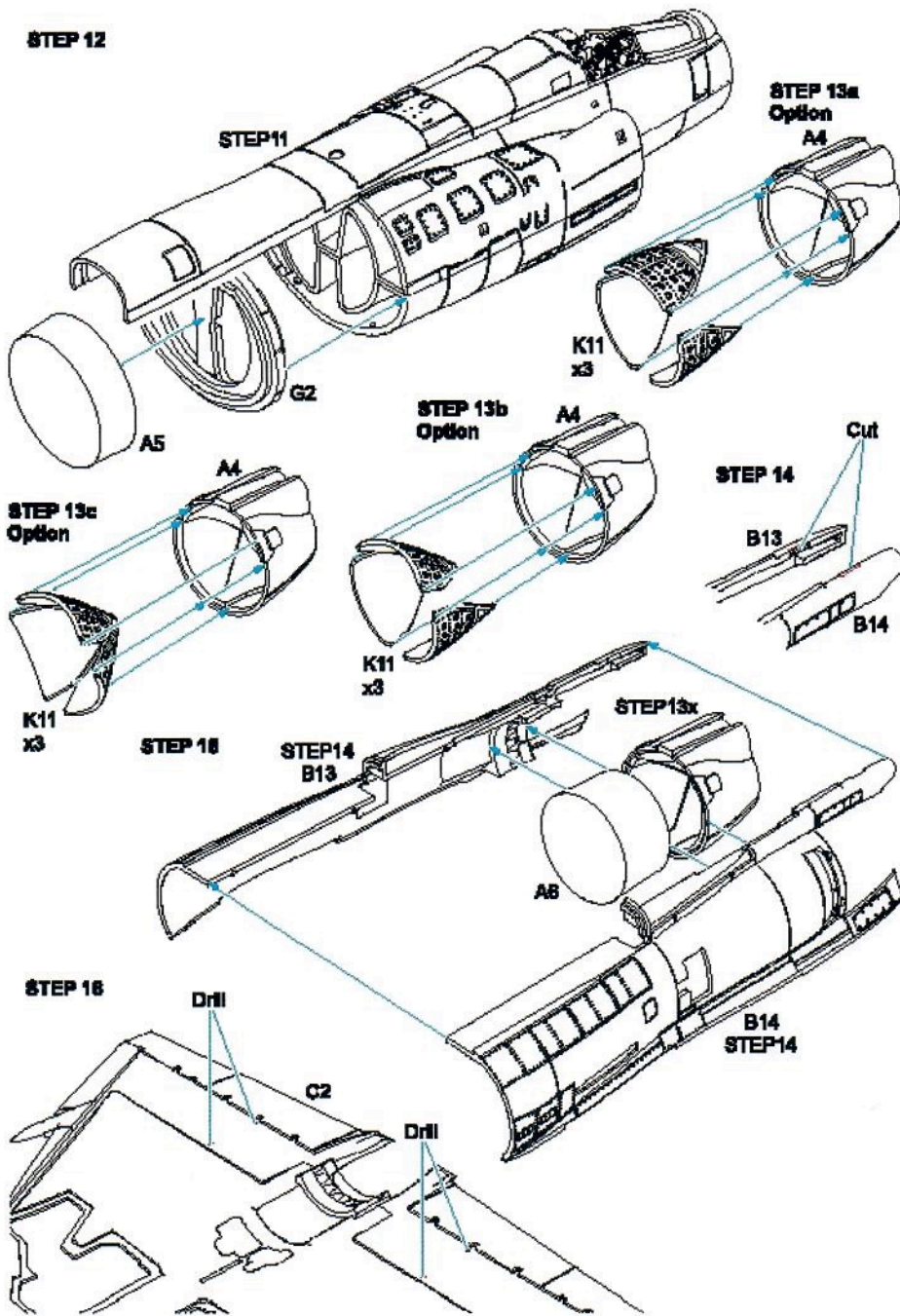

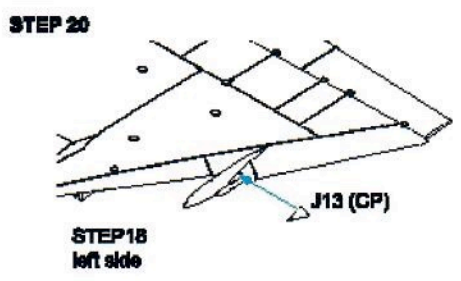
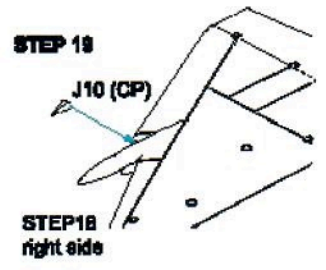
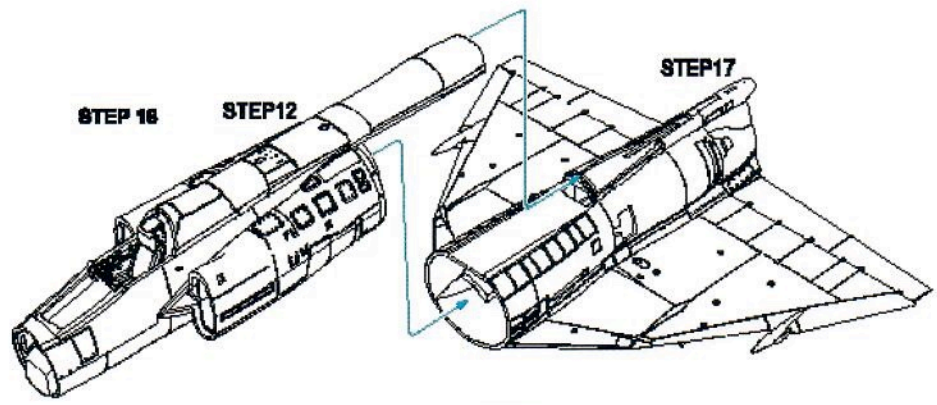
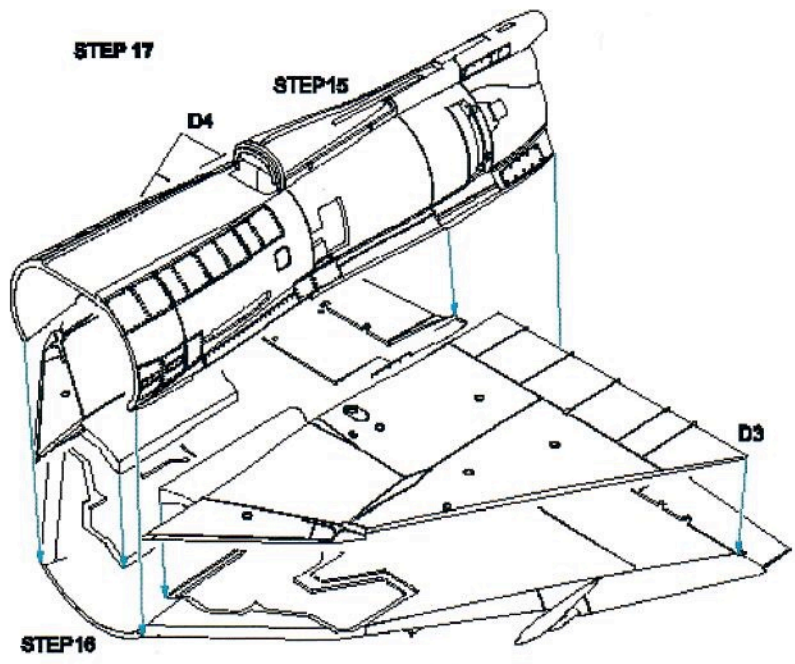

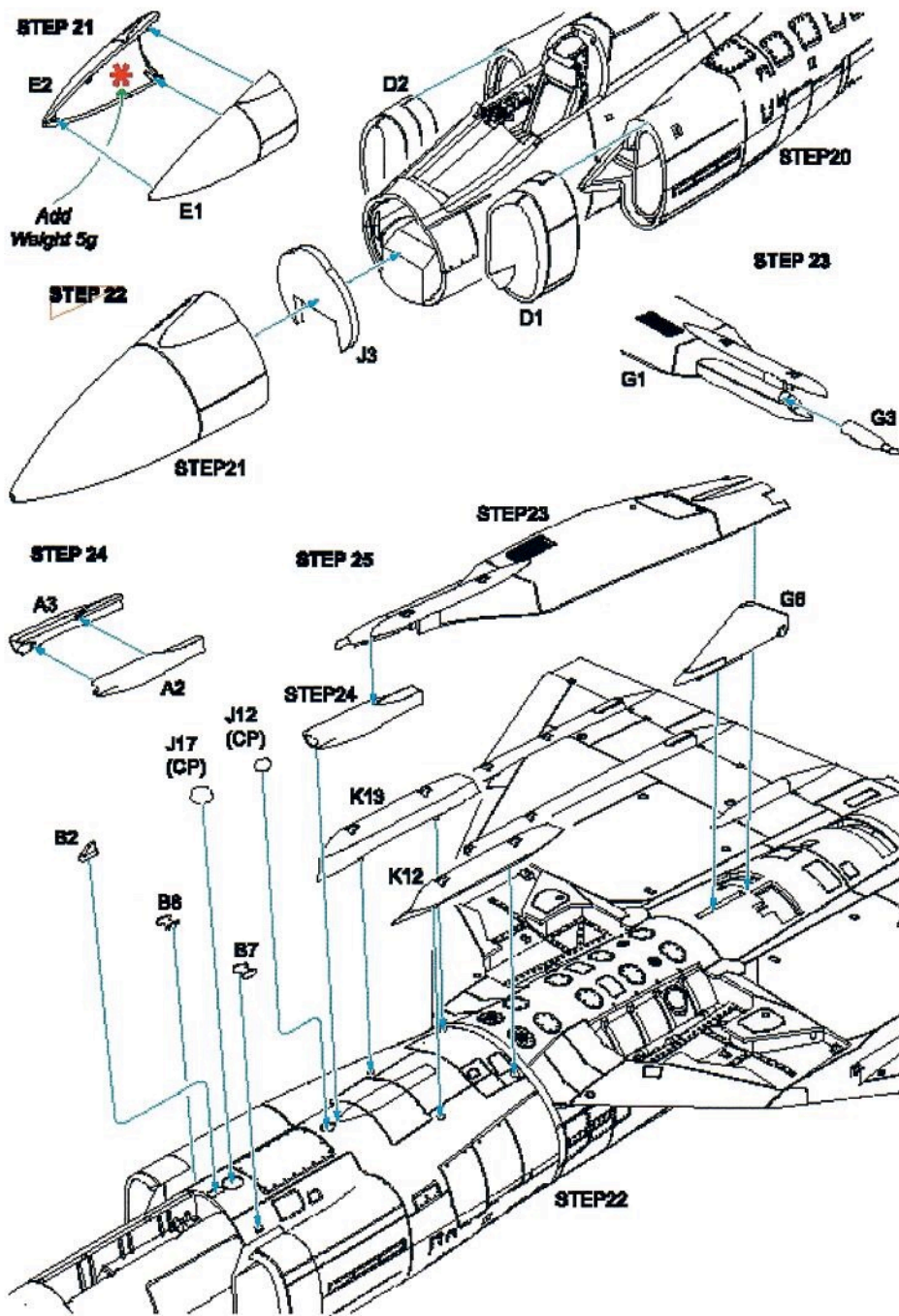



STEP 26

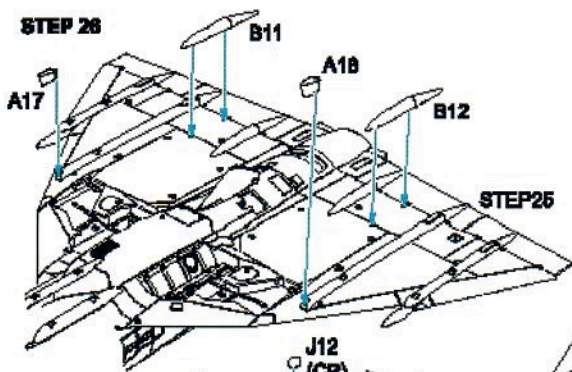

STEP 28

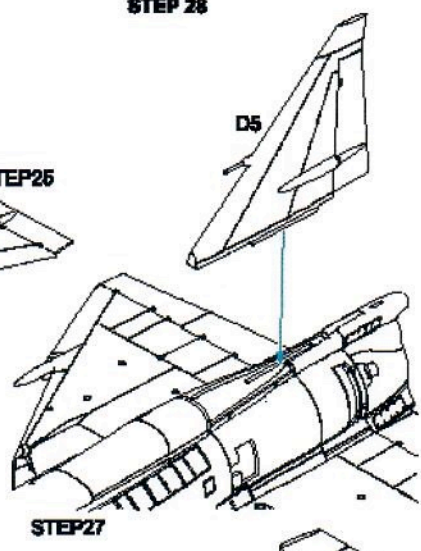

STEP 27

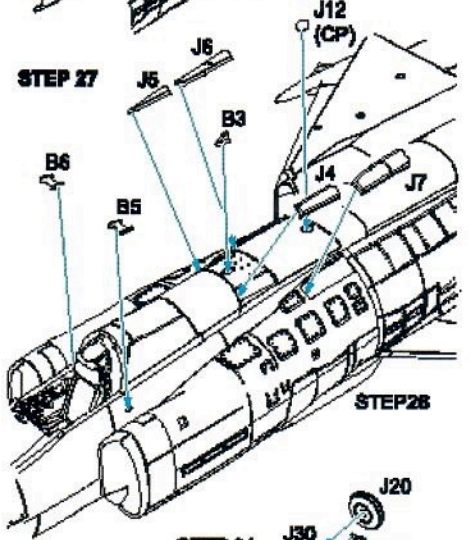

STEP 27

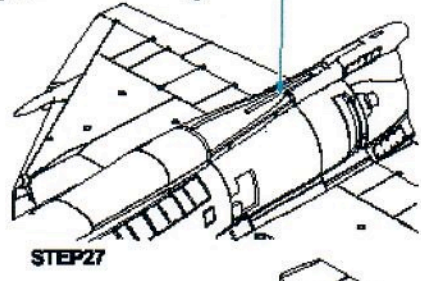

STEP 29

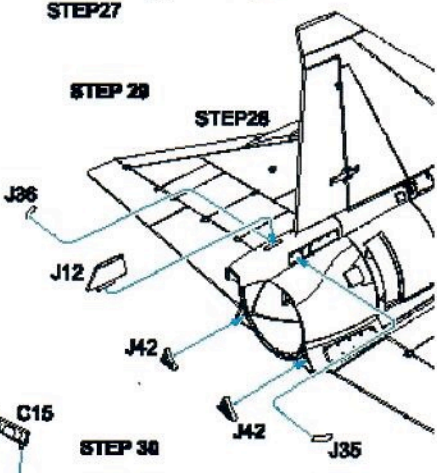

STEP 28

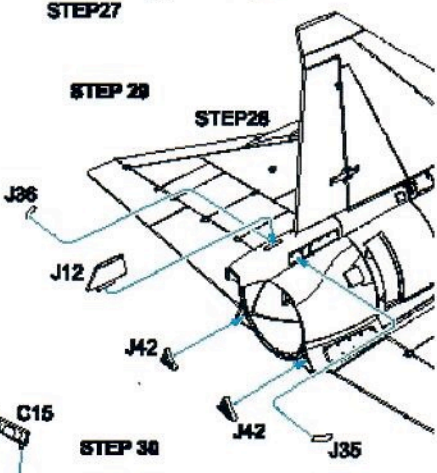

STEP 31

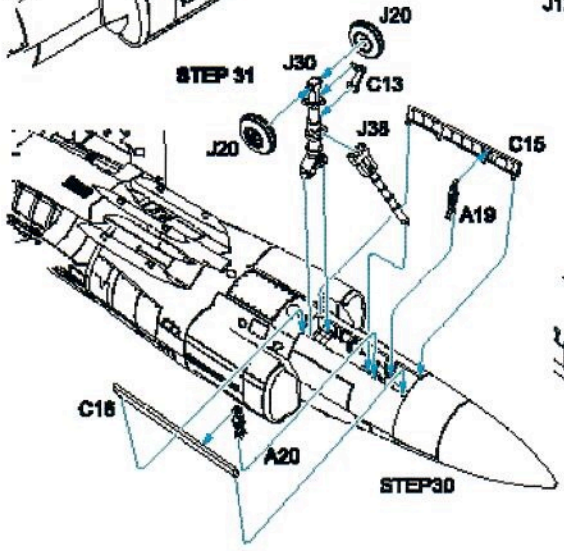

STEP 30

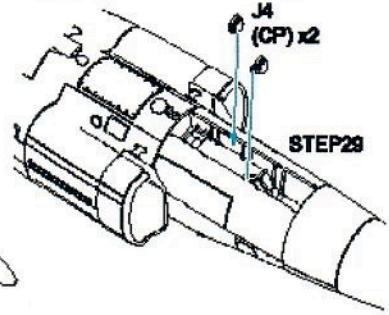

STEP 29

**STEP 32**

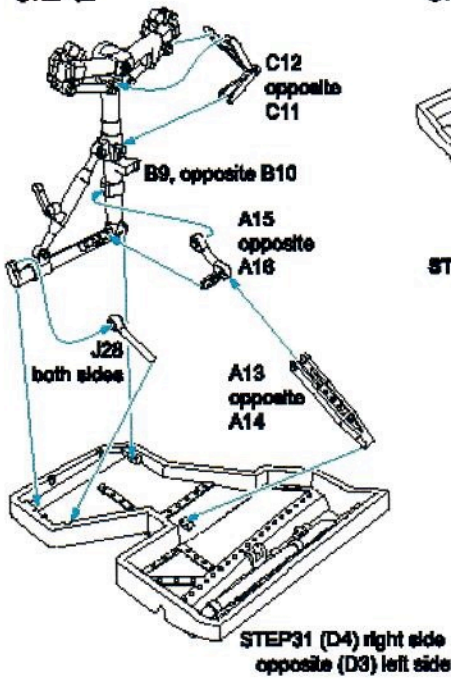

**STEP 33**

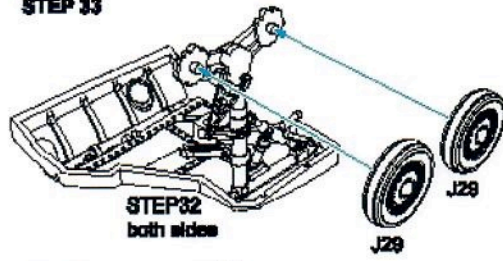

**STEP 34**

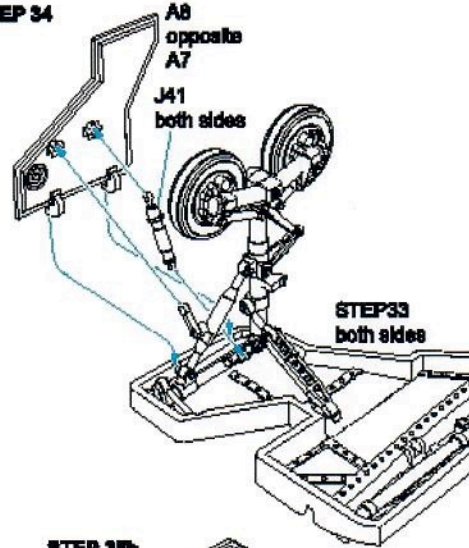

**STEP 35a**  
Option

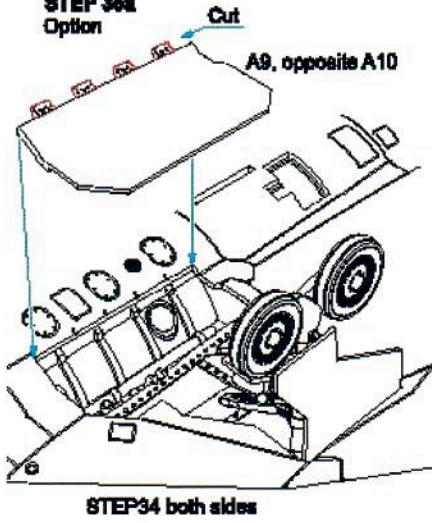

**STEP 35b**  
Option

