



✈ 467 mm ✈ 477 mm ✨ 549 mm

ENG

The Boeing C-40 Clipper is a military version of the Boeing 737 Next Generation used to transport cargo and passengers. First flight took place in April 2000 and the first of the C-40A aircraft entered service in April 2001.

The U.S. Navy Reserve was the first customer for a 737 Next Generation based "combi" aircraft (capable of transporting cargo and passengers). In the 2018 Marine Aviation Plan, the U.S. Marine Corps indicated that it intended to acquire two C-40A aircraft for airlift missions, replacing its Skytrain fleet. The United States Air Force selected the C-40B, a military version of the 737-700 Boeing Business Jet, to replace the aging fleet of C-137 aircraft used to transport U.S. combatant commanders.

technical data

Length: 33.63 m Span: 34.32 m Height: 12.55 m
Max take-off weight: 77 564 kg Payload capacity: 18 144 kg
Range: 9 300 km Cruising speed: 989 km/h
Ceiling: 12 000 m Crew: 9 persons

UKR

Boeing C-40 Clipper є військовою версією Boeing 737 Next Generation, яка використовувалася для перевезень вантажів та пасажирів. Перший політ C-40A відбувся в квітні 2000 року. Літак надійшов на озброєння у квітні 2001 року.

Резерв ВМС США був першим замовником 737 Next Generation, як літака "комбі" (здатного перевозити вантаж і пасажирів). У плані морської авіації на 2018 рік, Корпус морської піхоти США заявив, що має намір придбати два літаки C-40A для місій авіаперевезень, замінивши свій парк Skytrain. ВПС США вибрали C-40B, військову версію 737-700 Boeing Business Jet, щоб замінити застарілий парк літаків C-137, які використовувалися для транспортування бойового командування США.

технічні характеристики

Довжина: 33,63 м Розмах: 34,32 м Висота: 12,55 м
Максимальна злітна вага: 77 564 кг Корисна вага: 18 144 кг
Дальність: 9 300 км Крейсерська швидкість: 989 км/год.
Фактична стеля: 12 000 м Екіпаж: 9 чол.

assembly symbols / спеціальні умовні позначки для збирання



assembly options

варіанти збирання



use CA glue

використати «суперклеї»



do not cement

не клеїти



bend part

зігнути деталь



multiple times assembly

зібрати кілька



drill a hole

просвердити отвір



symmetrical assembly

симетричне збирання



cut off / cut out

відрізати / прорізати

A

White
Білий

H1 1 71.001

B

Flat Black
Чорний Матовий

H12 33 71.057

C

Light Grey (FS 36495)
Світло-сірий

H338 338 71.276

D

Grey (FS 36270)
Сірий нейтральний

H306 306 71.275

E

Grey (FS 36118)
Сірий

H305 305 71.097

F

Green (FS 34227)
Зелений

H312 312 71.126

G

Shine Silver / Chrome
Сріблястий / Хром

H8 90 77.707

H

Burnt Iron
Палений метал

H76 61 77.721

I

Steel
Сталь

H18 28 77.712

J

Tire Black
Гума

H77 137 71.315

K

Sky Blue
Небесно-блакитний

H25 34 70.841

L

Red
Червоний

H3 3 70.945

M

Clear Red
Прозорий червоний

H90 47 70.934

N

Clear Green
Прозорий зелений

H94 138 70.936

*



COLORS H304 304

COLORS 72.000

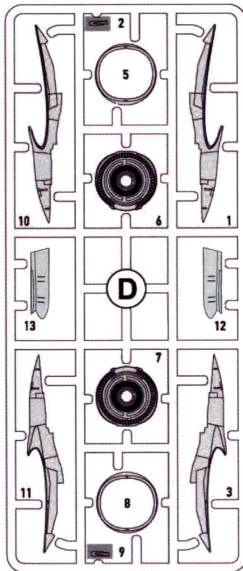
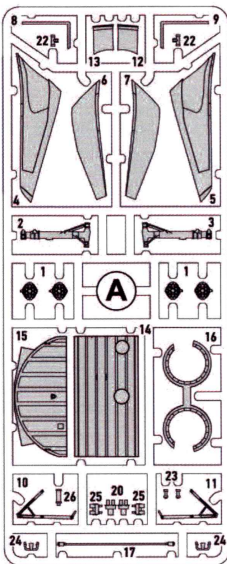
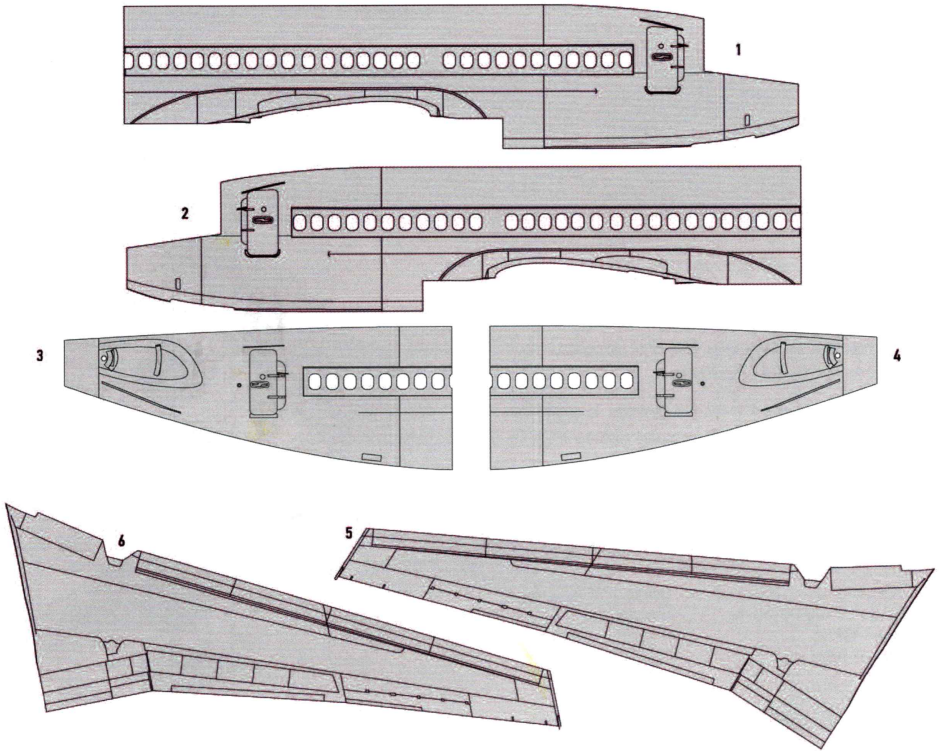

do not use / не використовувати

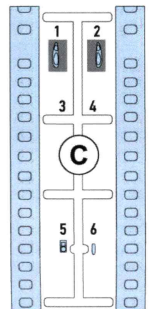
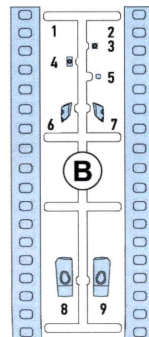
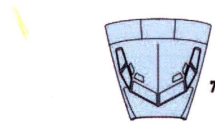

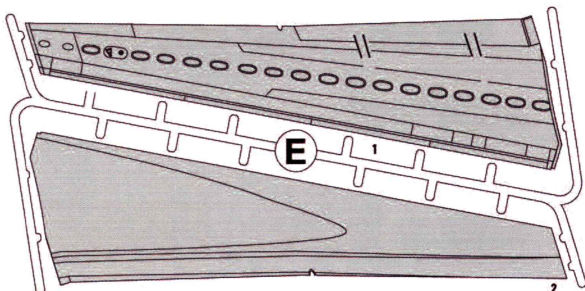
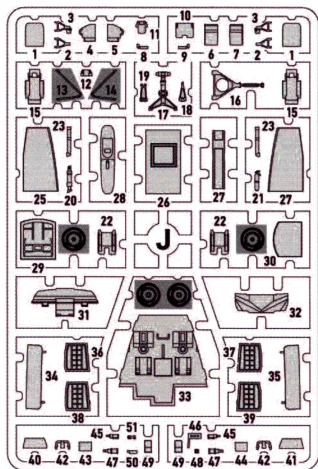
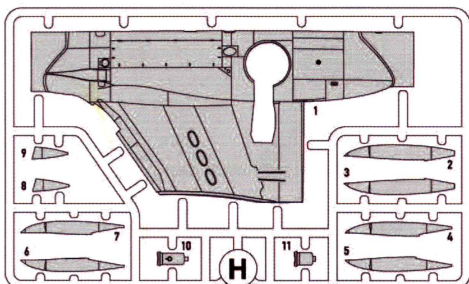
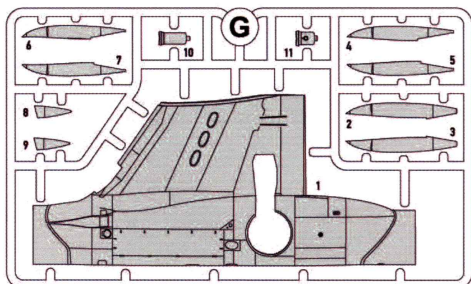
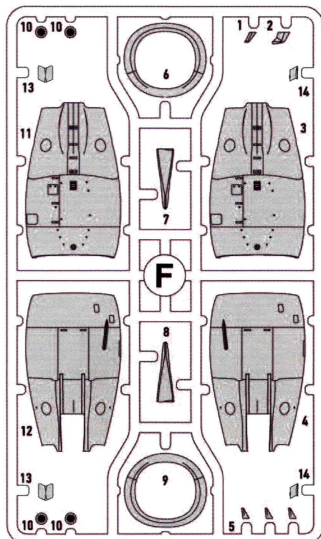
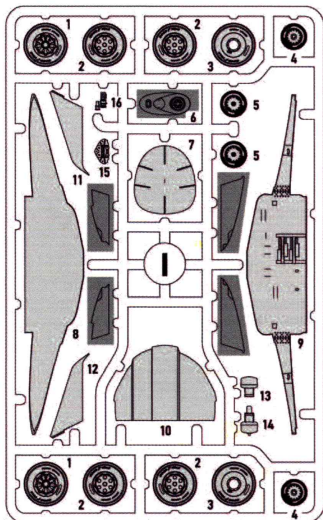

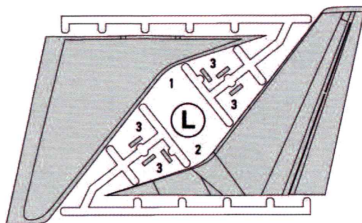
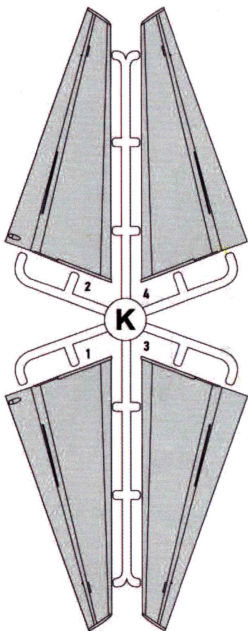

decals / деколі

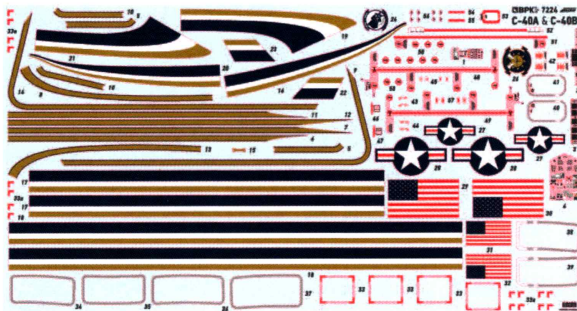

R

3D-printed parts / 3D-друковані деталі

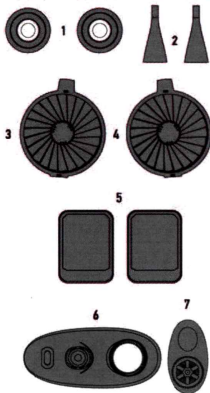
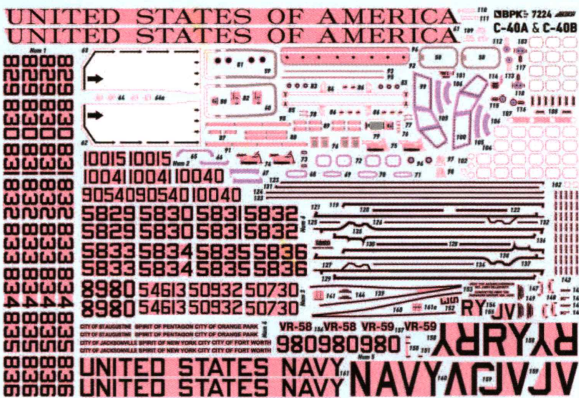
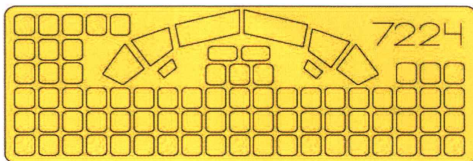
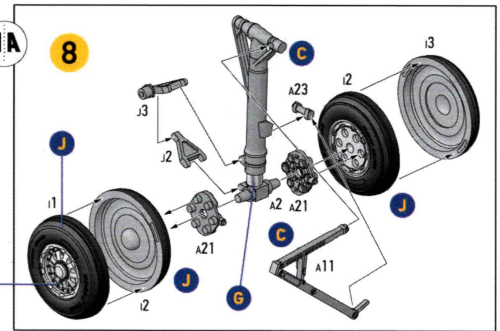
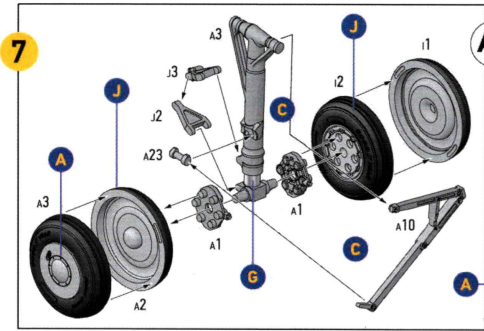
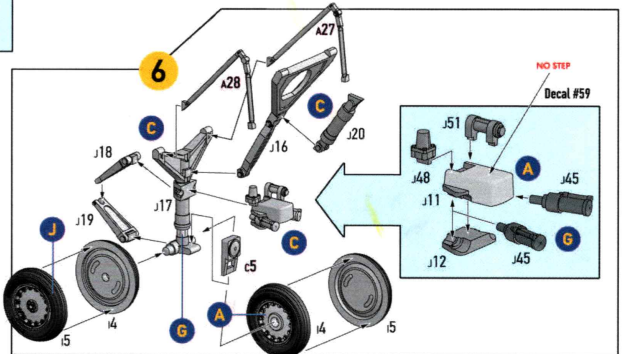
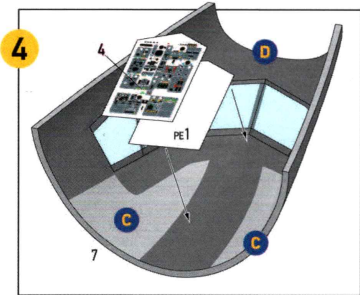
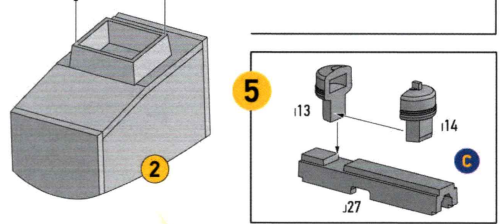
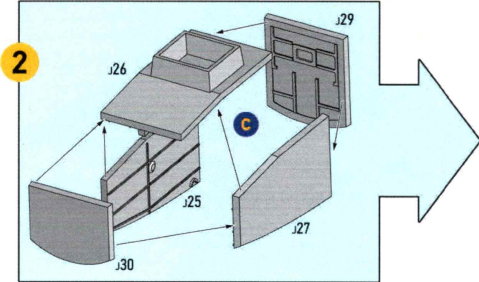
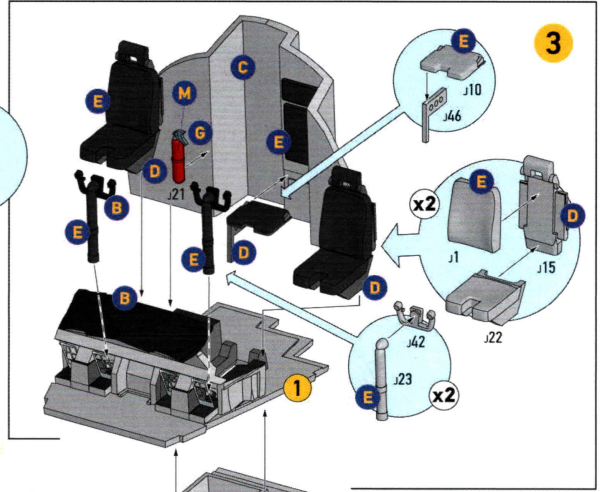
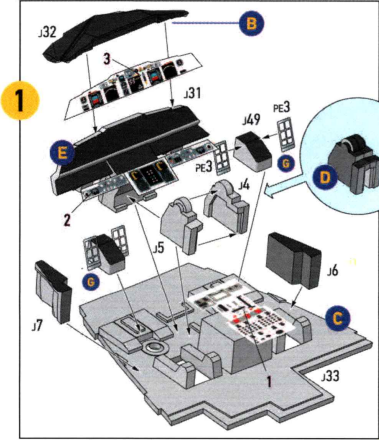

photo etched parts / фототравлені деталі



painting masks / маски для фарбування





9

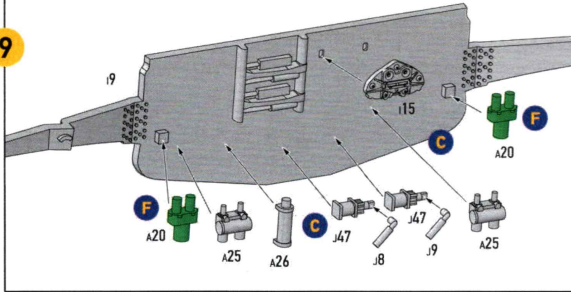

10

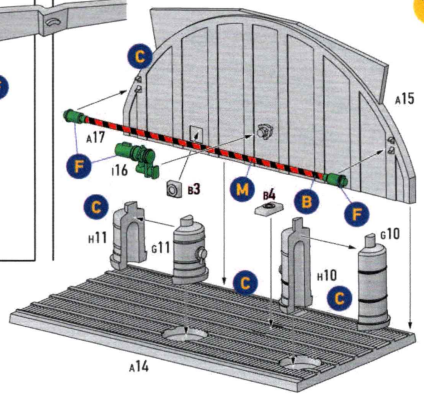

11

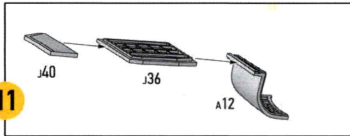

13

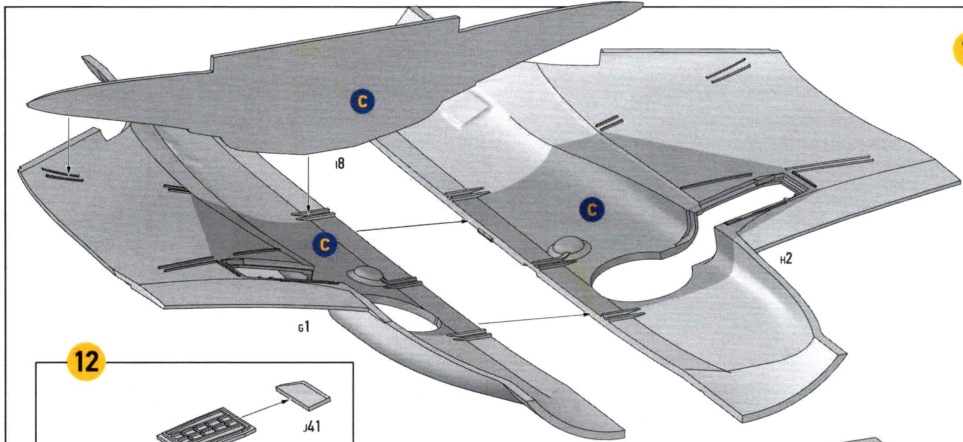

12

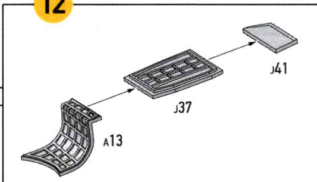

14

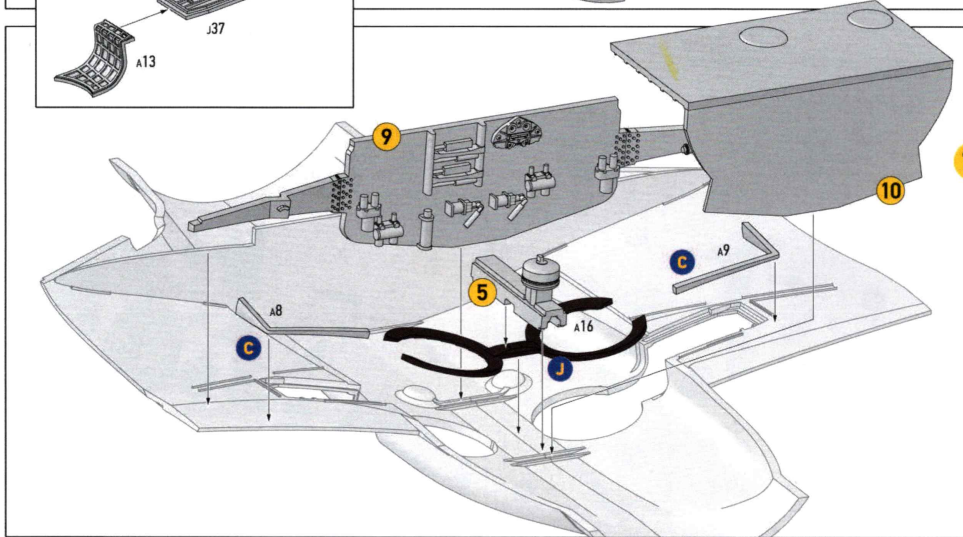

15

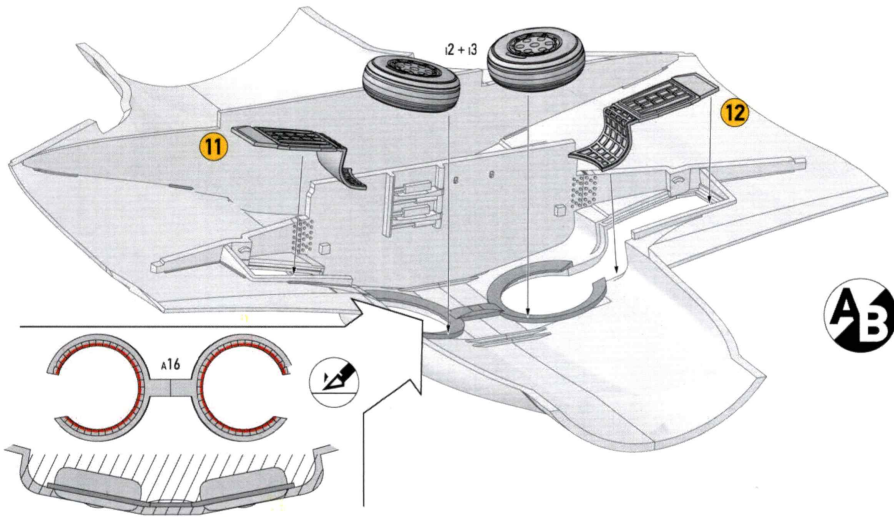

16

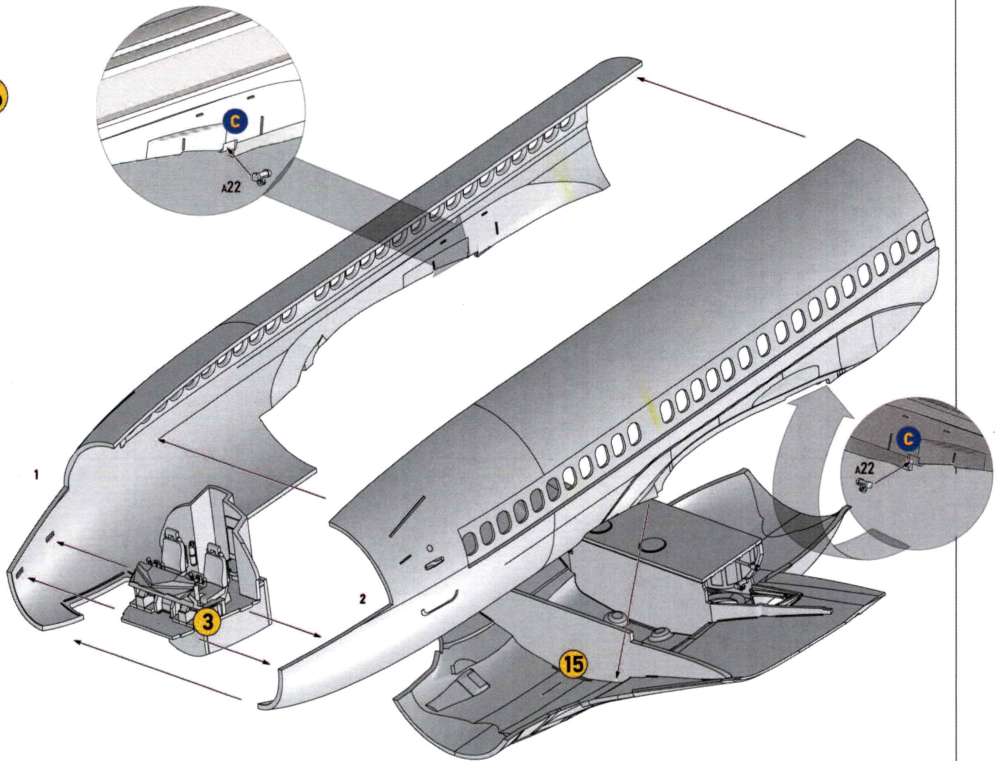

17

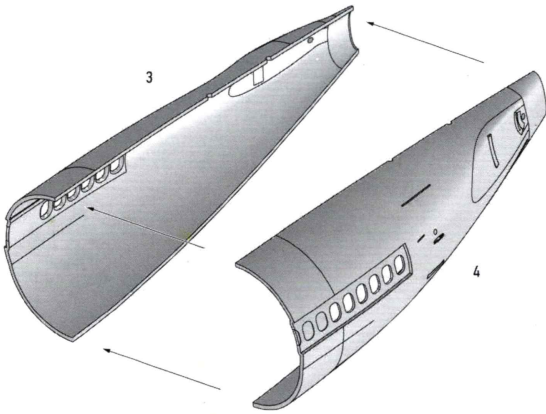

18

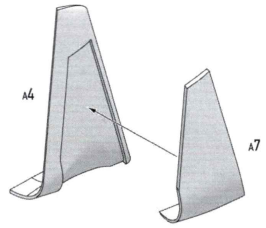

19

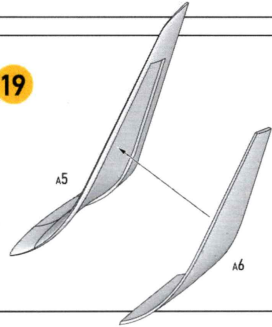

20

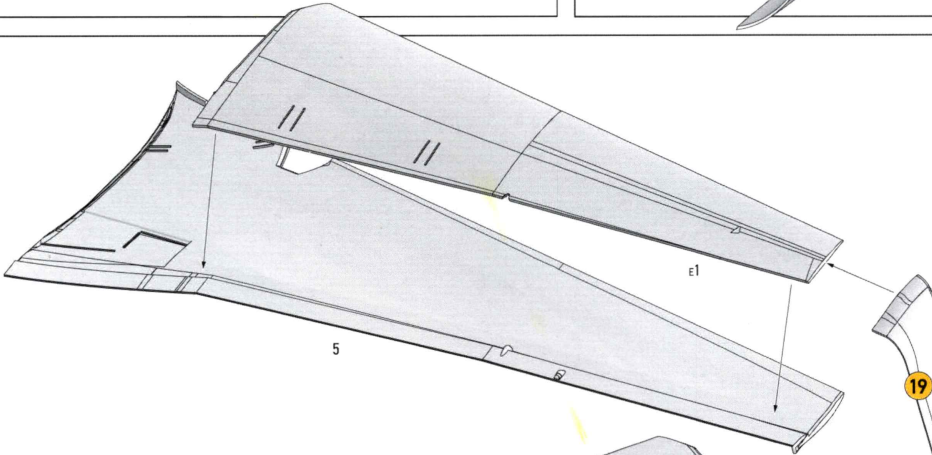

19

21

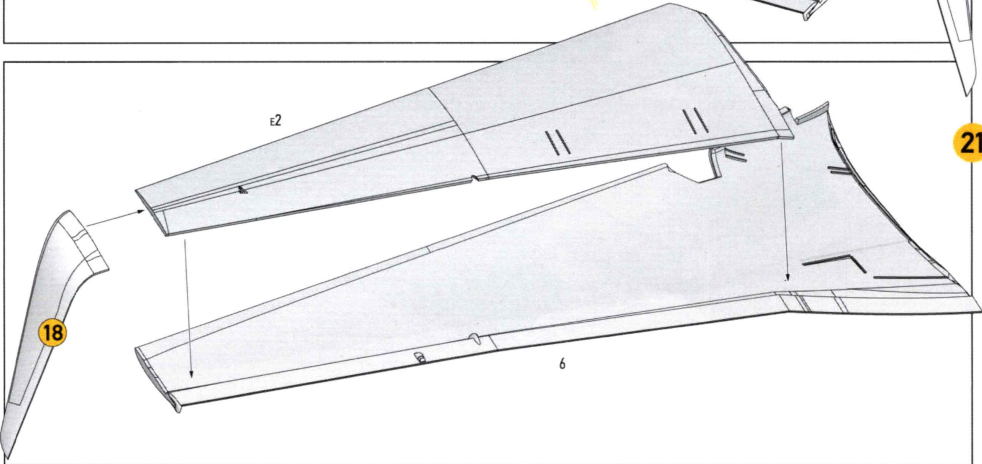

18

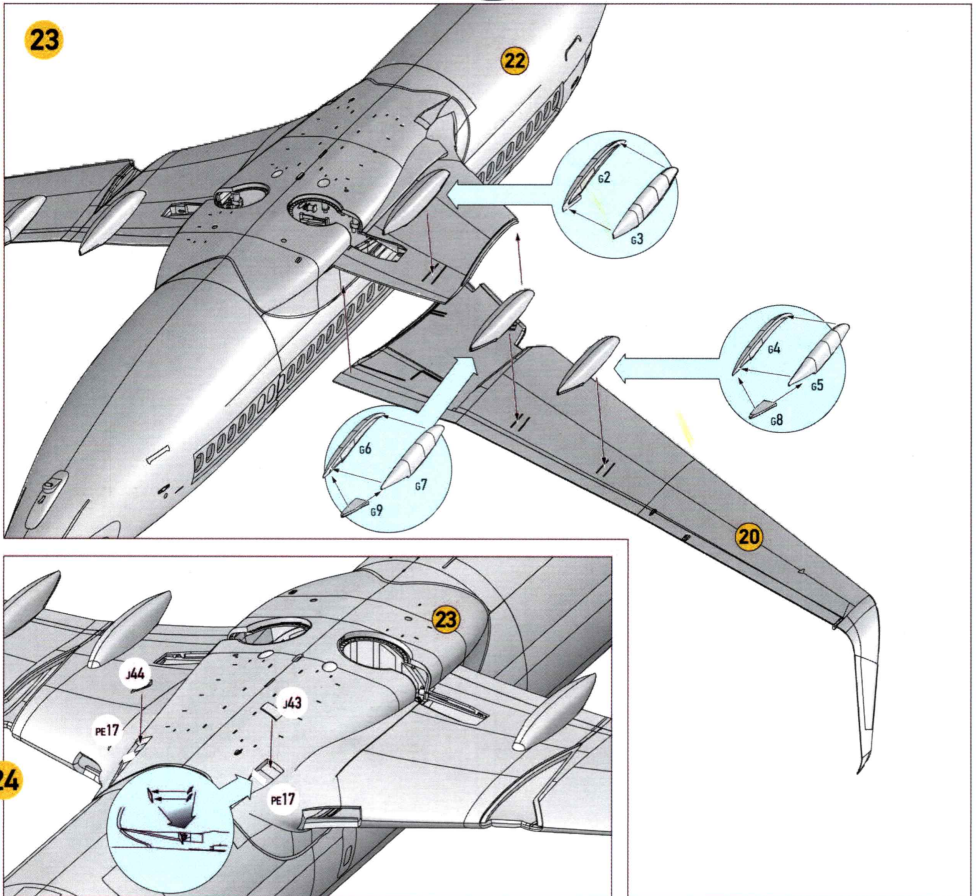
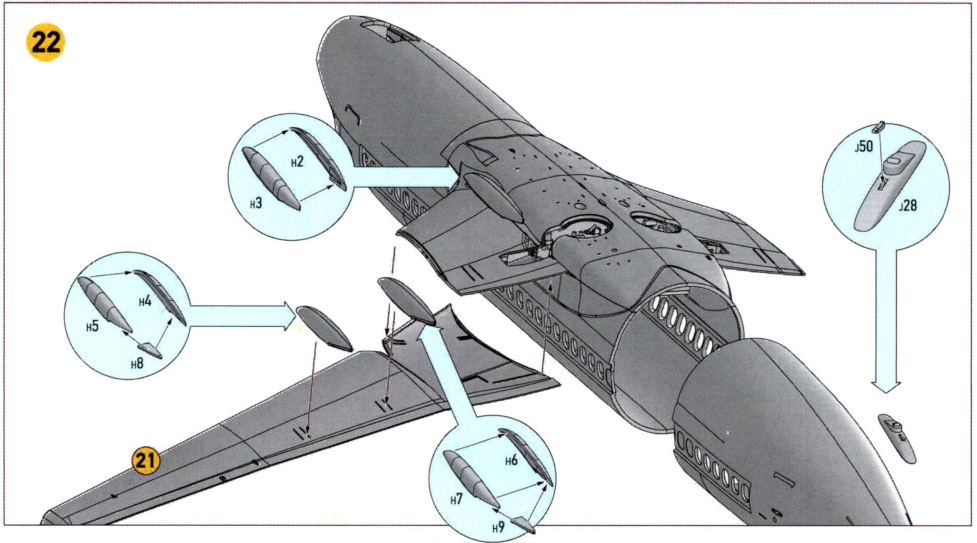

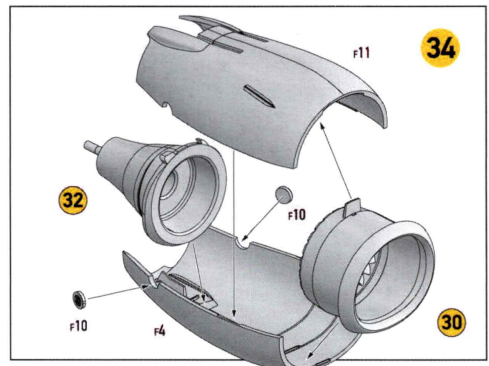
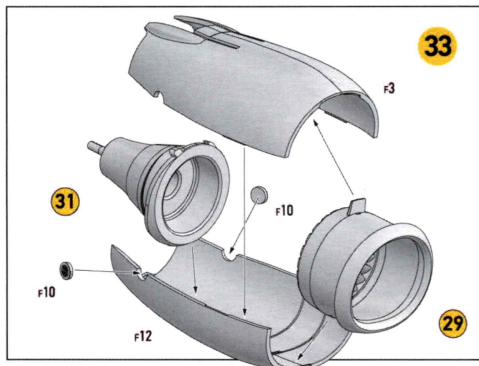
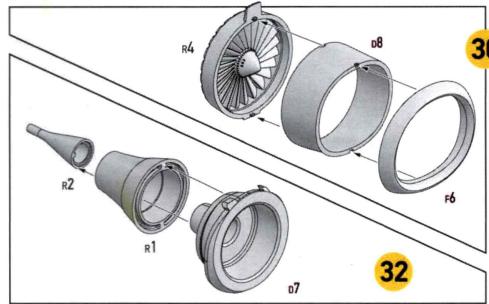
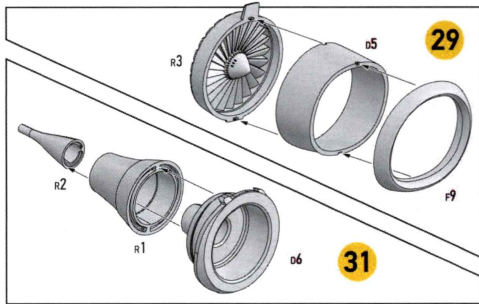
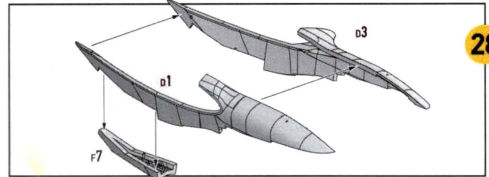
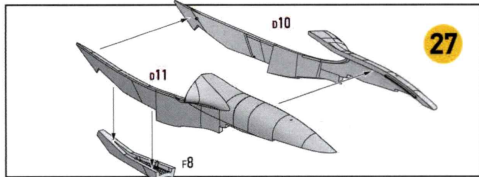
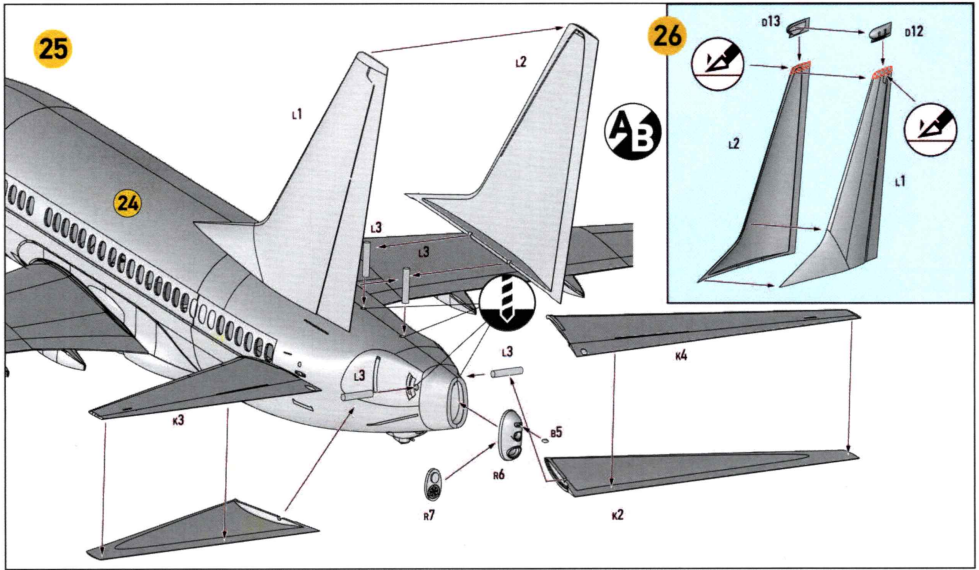

35

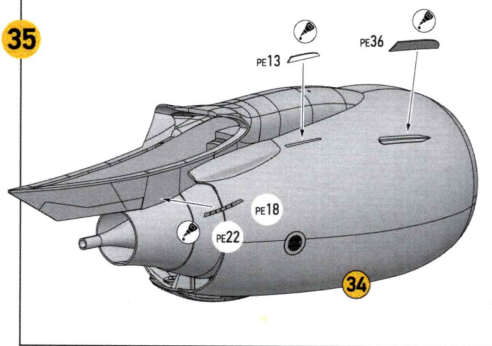

36

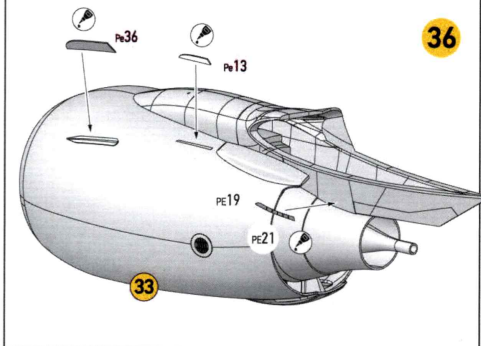

37

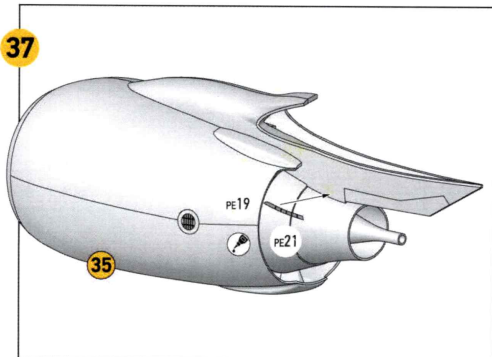

38

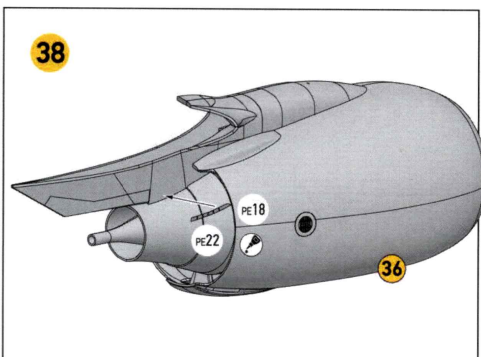

39

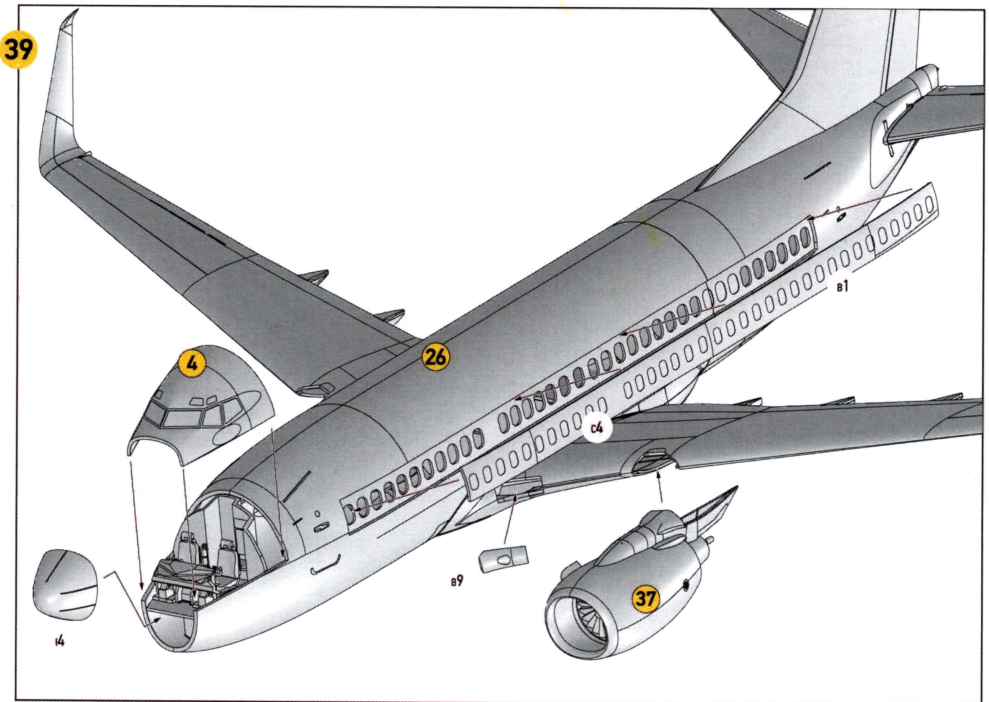

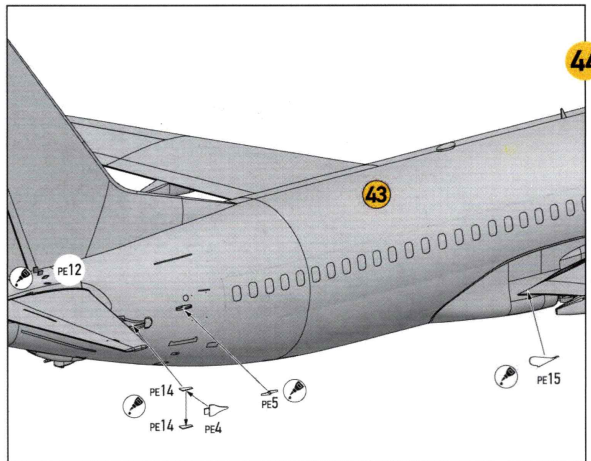
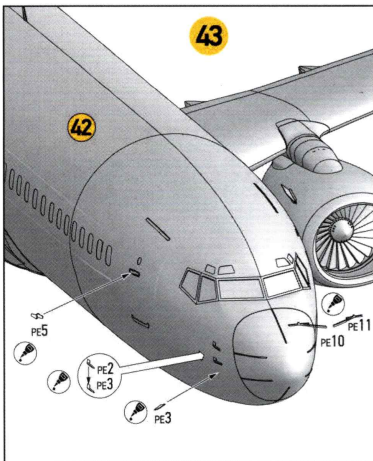
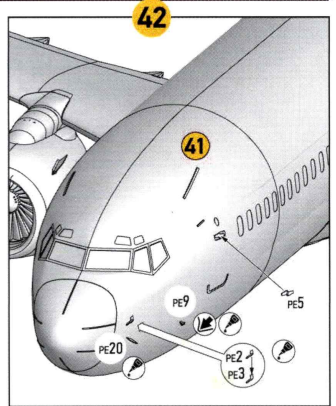
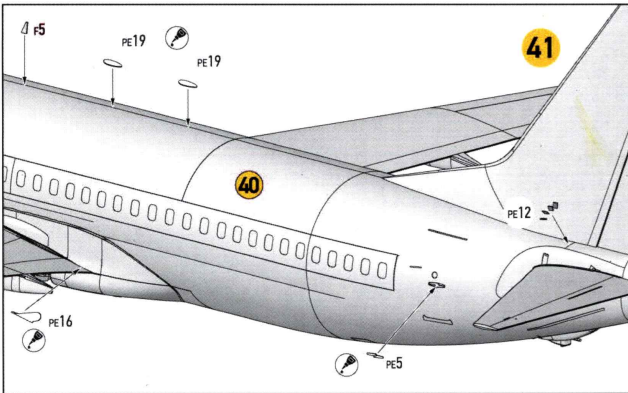
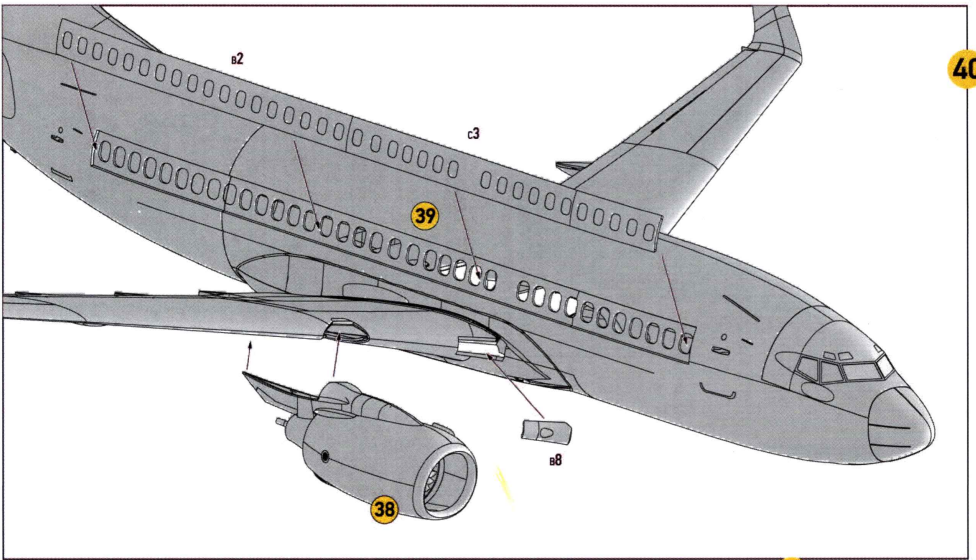

45

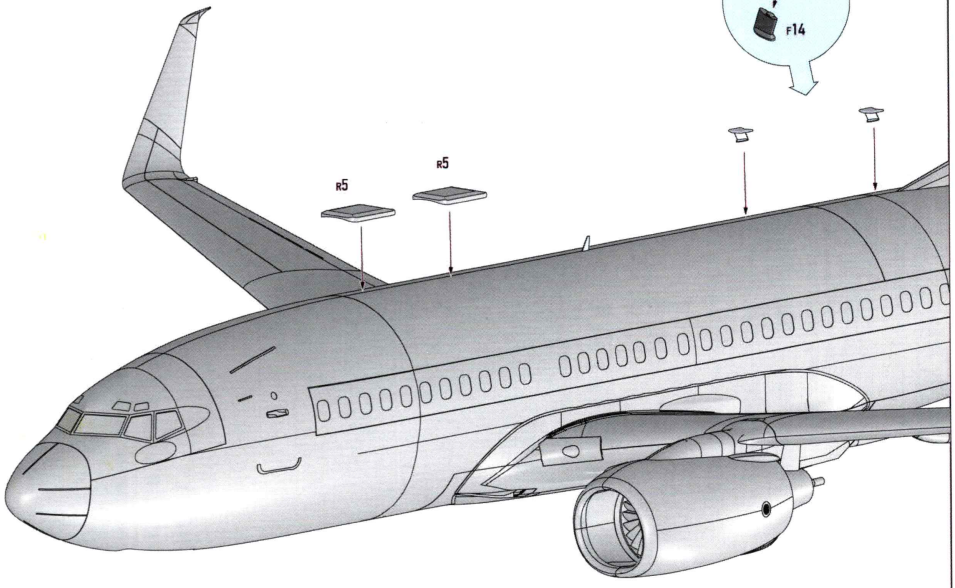
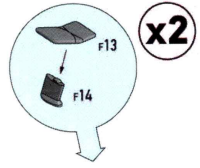

46

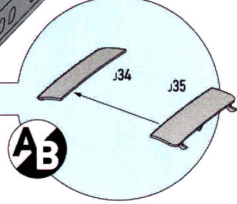
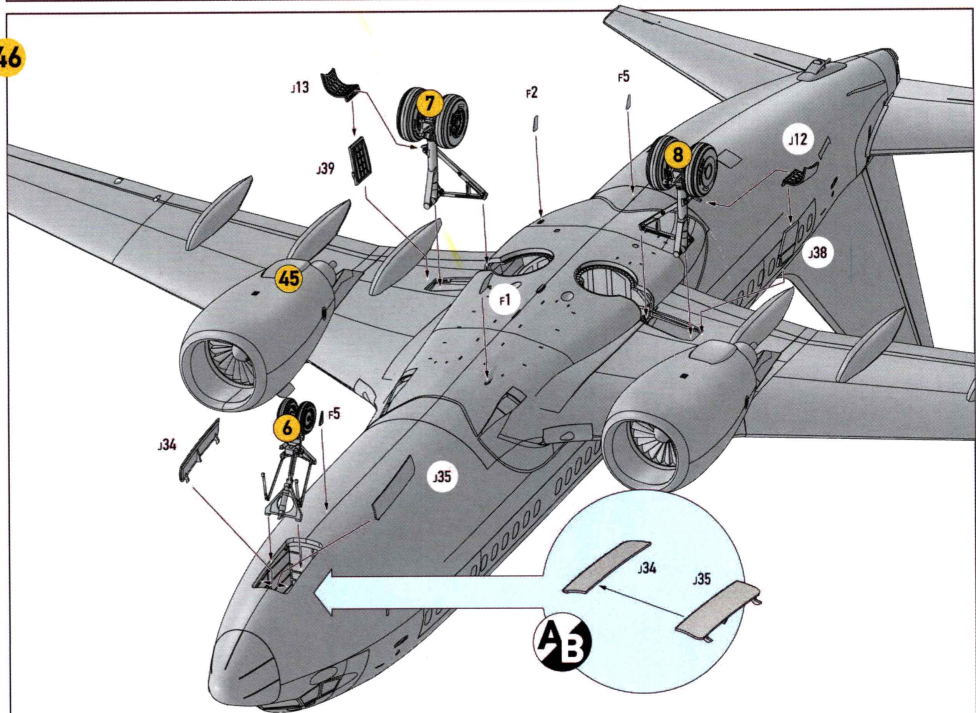

Fleet Logistics Support Squadron 59 (VR-59), Naval Air Station Joint Reserve Base, Fort Worth, Texas

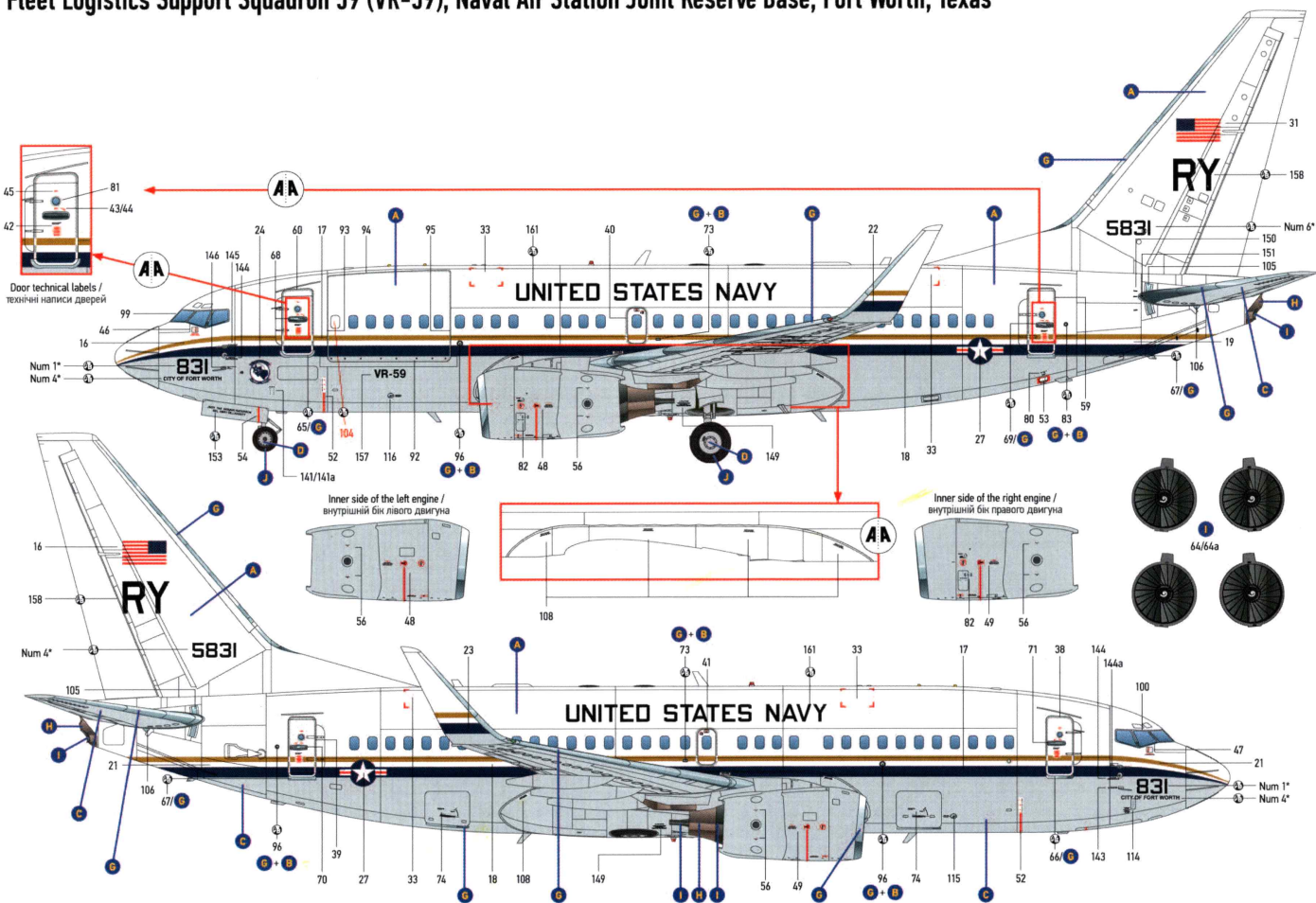

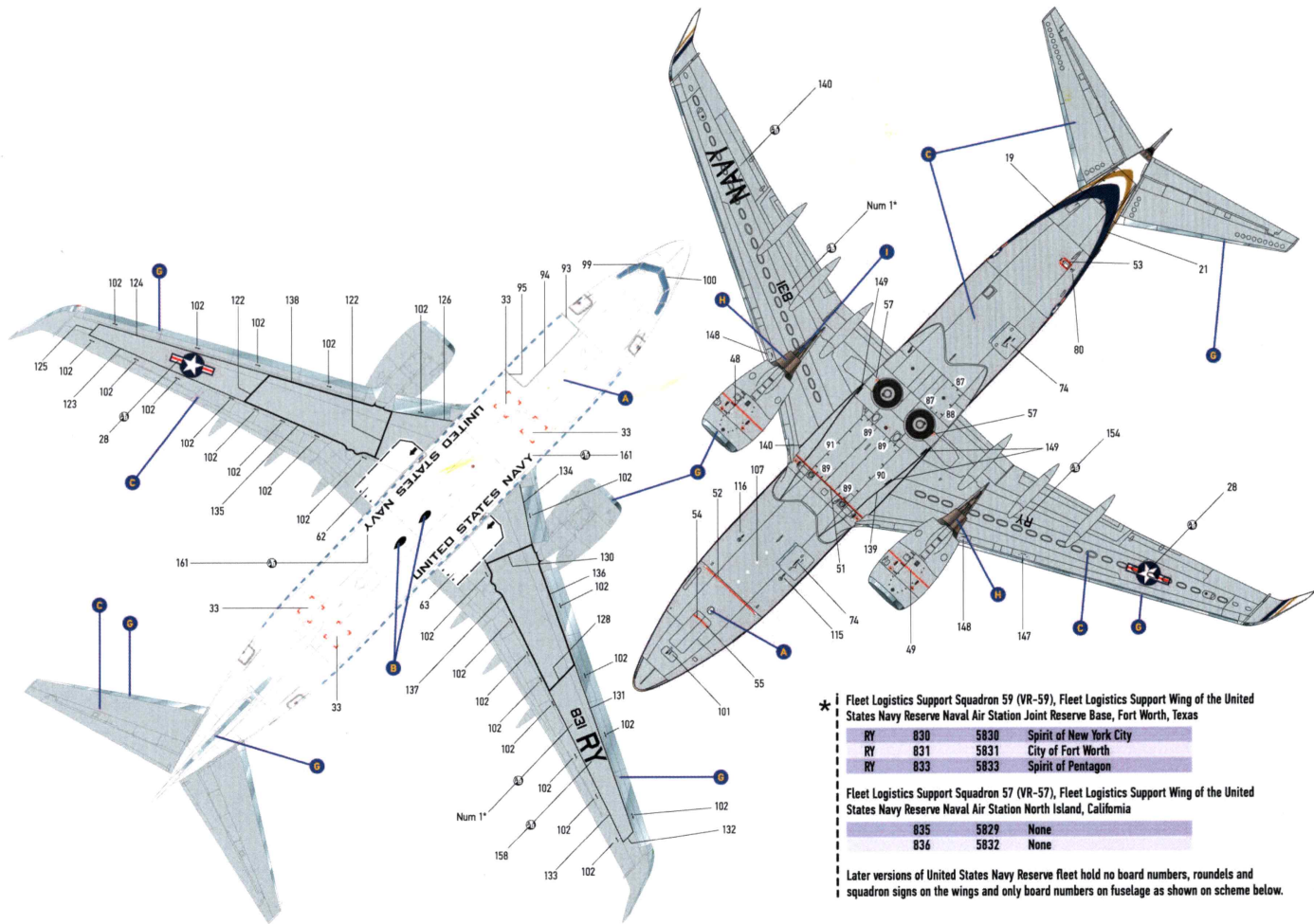

* Fleet Logistics Support Squadron 59 (VR-59), Fleet Logistics Support Wing of the United States Navy Reserve Naval Air Station Joint Reserve Base, Fort Worth, Texas

RY	830	5830	Spirit of New York City
RY	831	5831	City of Fort Worth
RY	833	5833	Spirit of Pentagon

Fleet Logistics Support Squadron 57 (VR-57), Fleet Logistics Support Wing of the United States Navy Reserve Naval Air Station North Island, California

	835	5829	None
	836	5832	None

Later versions of United States Navy Reserve fleet hold no board numbers, roundels and squadron signs on the wings and only board numbers on fuselage as shown on scheme below.

Fleet Logistics Support Squadron 58 (VR-58), Naval Air Station, Jacksonville, Florida

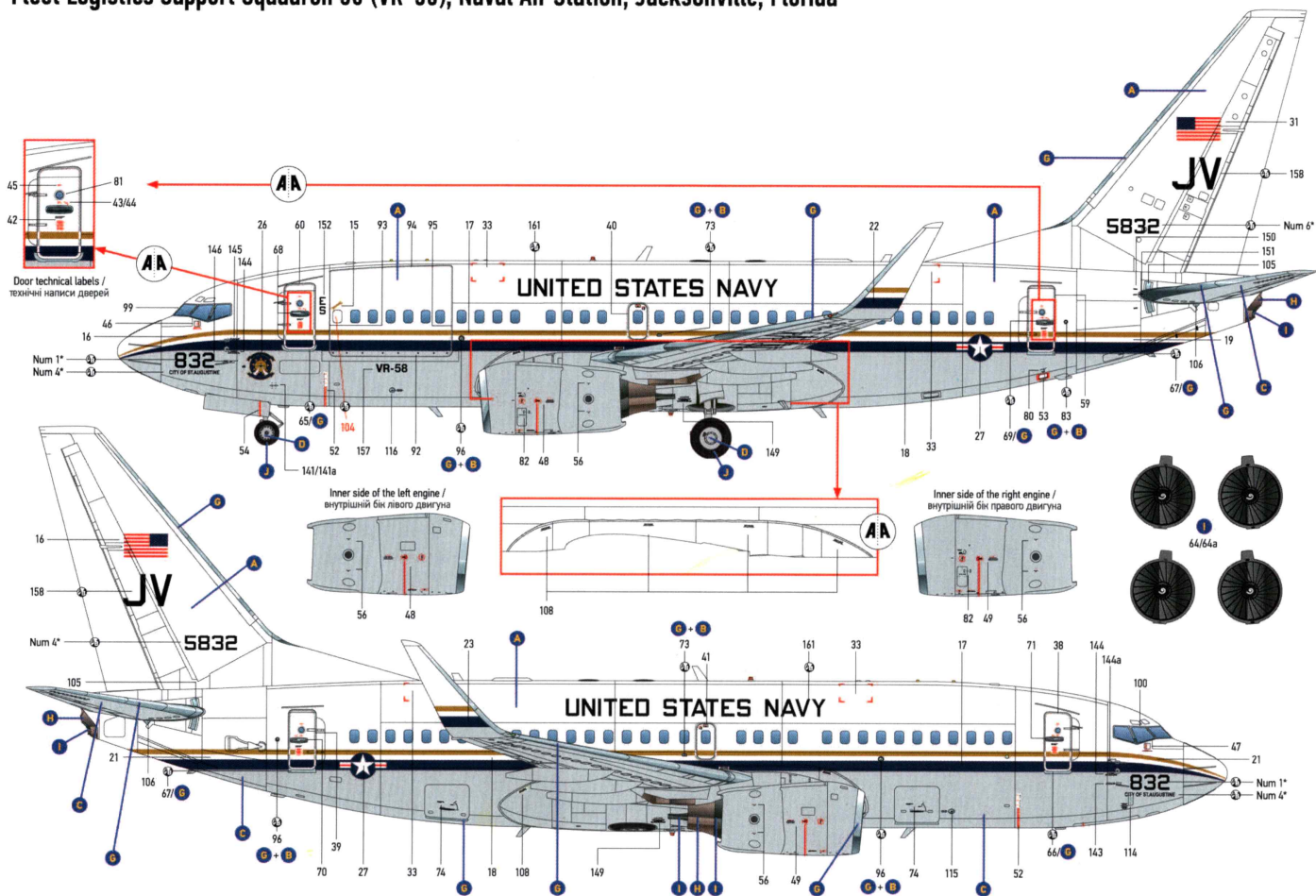

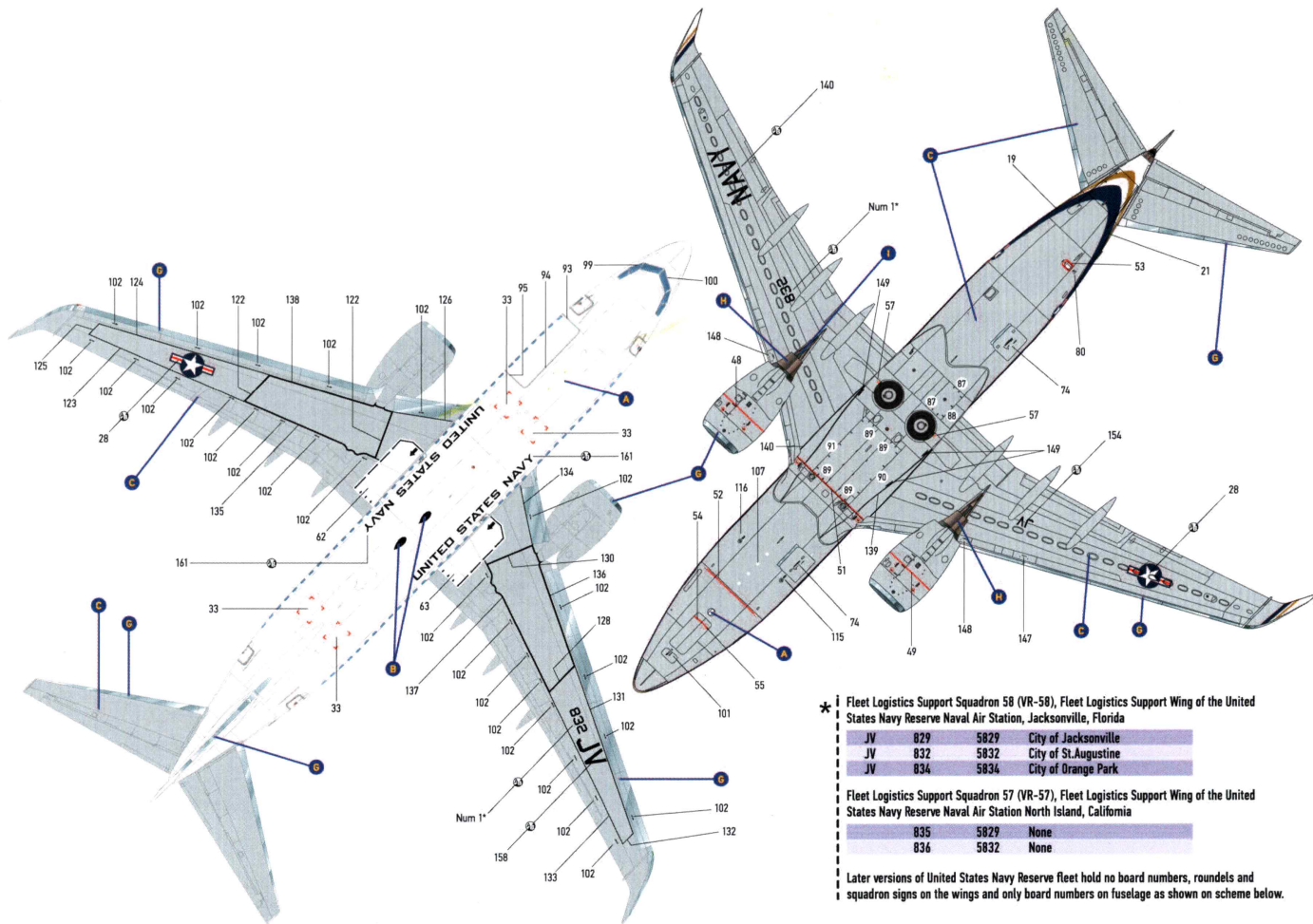

* Fleet Logistics Support Squadron 58 (VR-58), Fleet Logistics Support Wing of the United States Navy Reserve Naval Air Station, Jacksonville, Florida

JV	829	5829	City of Jacksonville
JV	832	5832	City of St. Augustine
JV	834	5834	City of Orange Park

Fleet Logistics Support Squadron 57 (VR-57), Fleet Logistics Support Wing of the United States Navy Reserve Naval Air Station North Island, California

	835	5829	None
	836	5832	None

Later versions of United States Navy Reserve fleet hold no board numbers, roundels and squadron signs on the wings and only board numbers on fuselage as shown on scheme below.

Fleet Logistics Support Squadron 61 (VR-61), Fleet Logistics Support Wing of the United States Navy Reserve

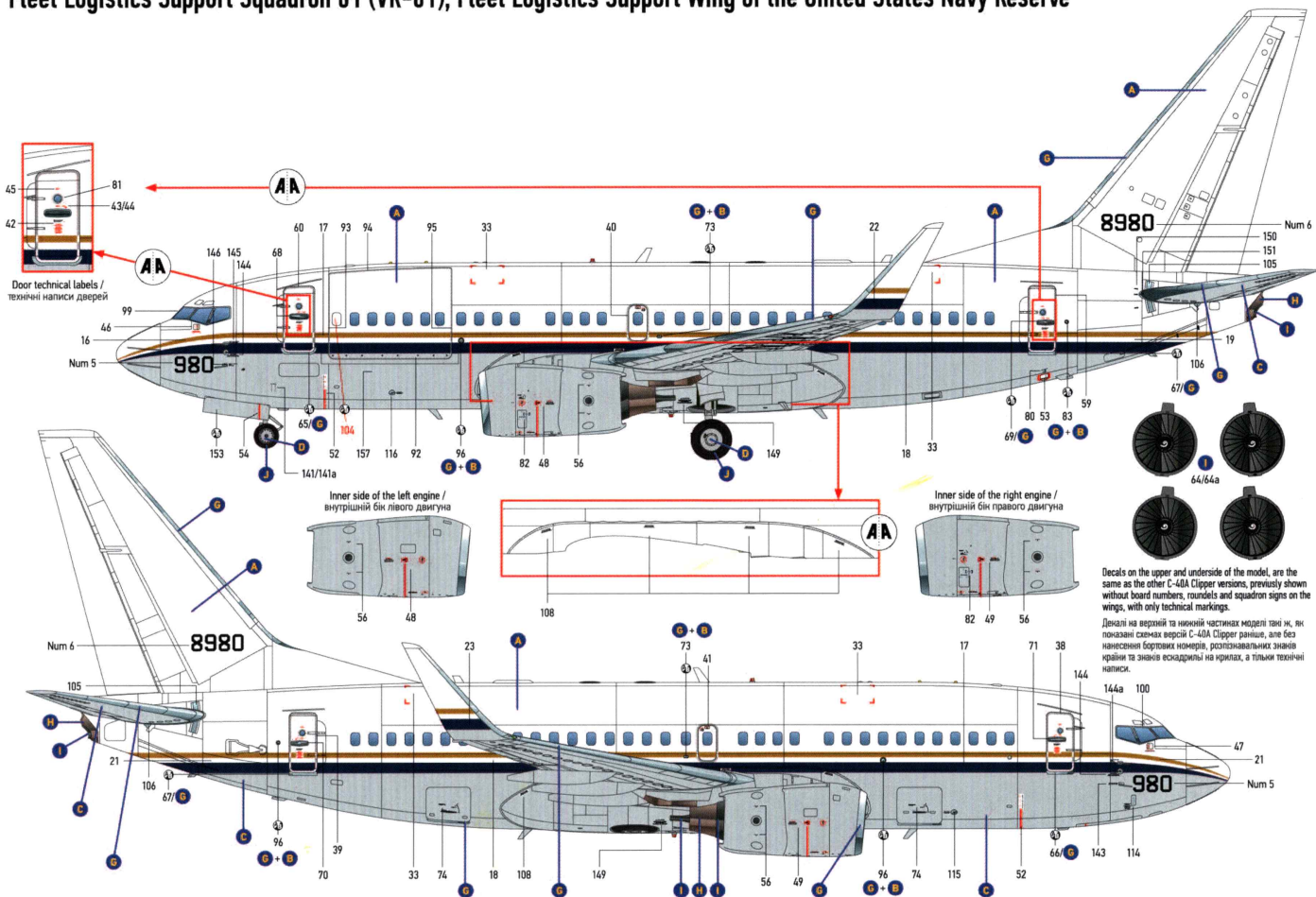

89th Airlift Wing, United States Department of State, Camp Springs, Joint Base Andrews, Maryland, United States of America

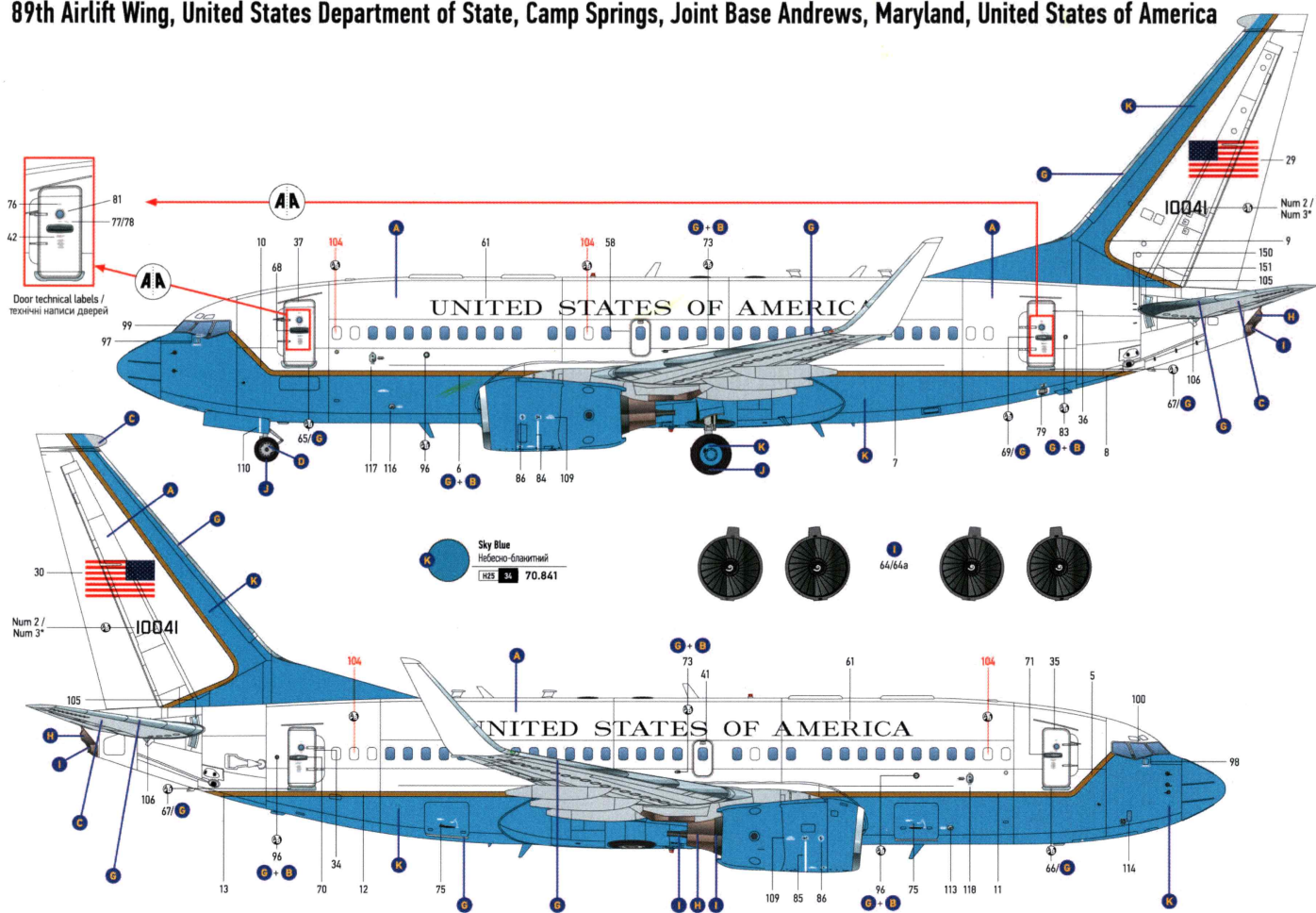

Door technical labels /
технічні написи дверей

Sky Blue
Небесно-блакитний
HS 34 70.841

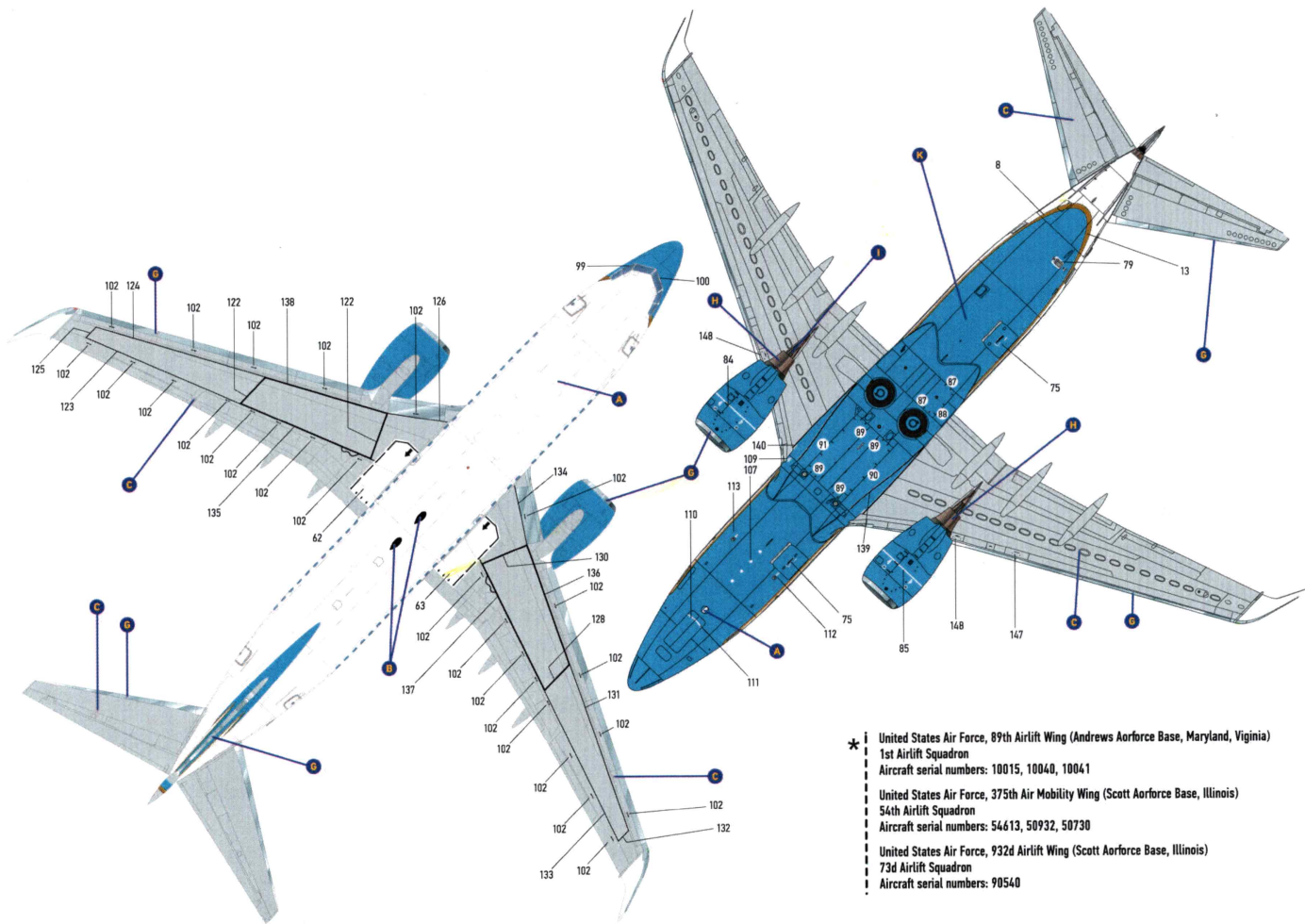

- * United States Air Force, 89th Airlift Wing (Andrews Air Force Base, Maryland, Virginia)
1st Airlift Squadron
Aircraft serial numbers: 10015, 10040, 10041
- United States Air Force, 375th Air Mobility Wing (Scott Air Force Base, Illinois)
54th Airlift Squadron
Aircraft serial numbers: 54613, 50932, 50730
- United States Air Force, 932d Airlift Wing (Scott Air Force Base, Illinois)
73d Airlift Squadron
Aircraft serial numbers: 90540

UNITED STATES OF AMERICA

UNITED STATES OF AMERICA

110 **BPK** 7224/2 **ALUSI**
 111 **C-40A & C-40B**
 112 103

Num 1

000000
 222222
 666666
 888888
 333333
 000000
 888888
 333333
 000000
 555555
 888888
 333333
 000000
 444444
 888888
 333333
 555555
 888888
 333333
 999999

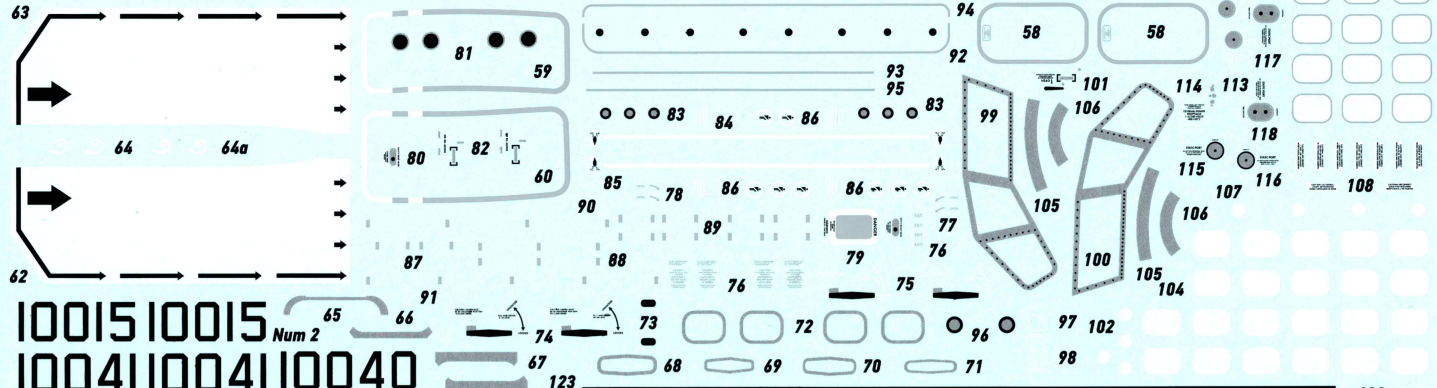

1001510015

100411004110040

905409054010040

5829 5830 5831 5832

5829 5830 5831 5832

5833 5834 5835 5836

5833 5834 5835 5836

8980 54613 50932 50730

8980 54613 50932 50730

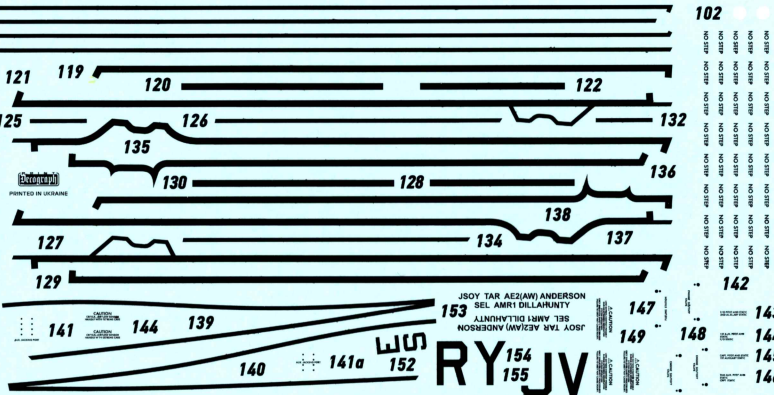

CITY OF ST.AUGUSTINE SPIRIT OF PENTAGON CITY OF ORANGE PARK
 CITY OF ST.AUGUSTINE SPIRIT OF PENTAGON CITY OF ORANGE PARK
 CITY OF JACKSONVILLE SPIRIT OF NEW YORK CITY CITY OF FORT WORTH
 CITY OF JACKSONVILLE SPIRIT OF NEW YORK CITY CITY OF FORT WORTH

VR-58¹⁵⁶ VR-58 VR-59¹⁵⁷ VR-59

980980980

RYJV

RYRYRY

NAVY¹⁶¹ NAVY¹⁶⁰ NAVY¹⁵⁹ NAVY¹⁵⁹

