



Royal Australian Air Force

A72-76 B-24I

25 Squadron

AUSTRALIA
 U.S. ARMY B-24L-1-CO
 AIR FORCES SERIAL 44-41402
 SUITABLE FOR AROMATICS
 SERVICE THIS AIRCRAFT WITH 100
 OCTANE FUEL IF NOT AVAILABLE
 T.O.D. 8-1 WILL BE CONSULTED
 FOR EMERGENCY ACTION
 EXCEPT A.F.C.E

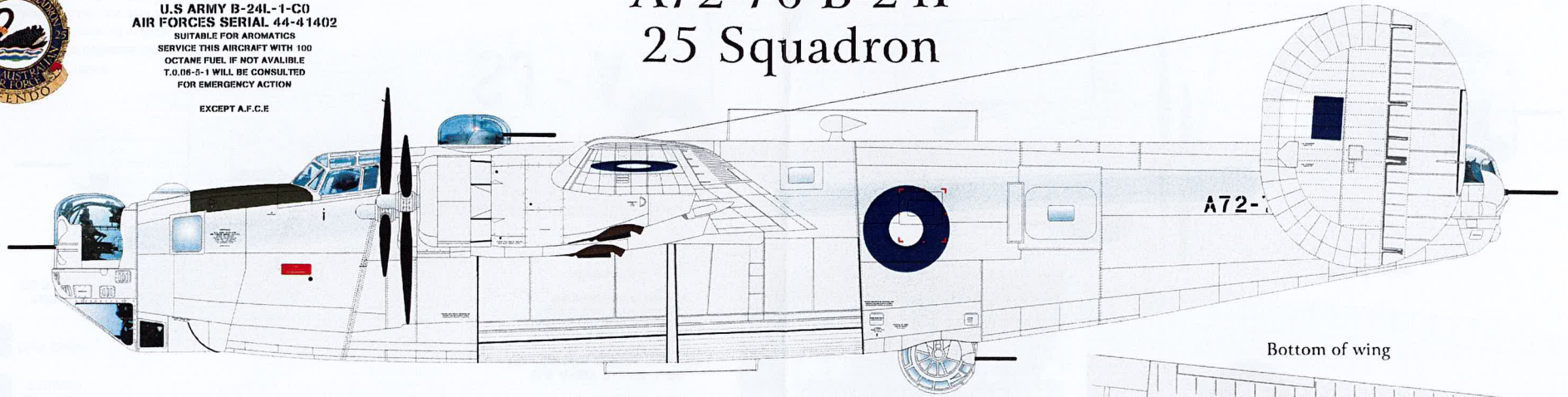

Bottom of wing

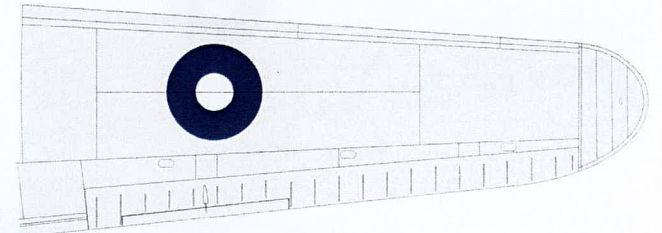
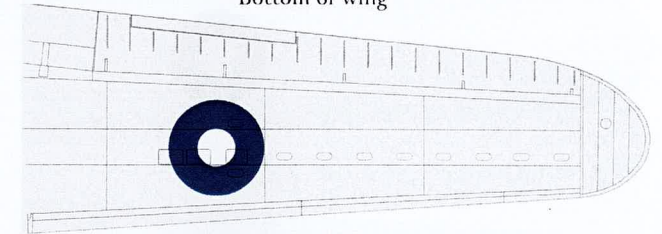

Top of wing

-  Matt Black
FS27038
-  Overall
Chrome Silver
-  Olive Drab
FS34087
-  Dark Brown
-  Yellow
FS-33538



Propeller

Note:

When these were delivered to the RAAF
 they were covered in data.
 As time went on, not all the data was applied.
 For Data Placement see Data Placement sheets.

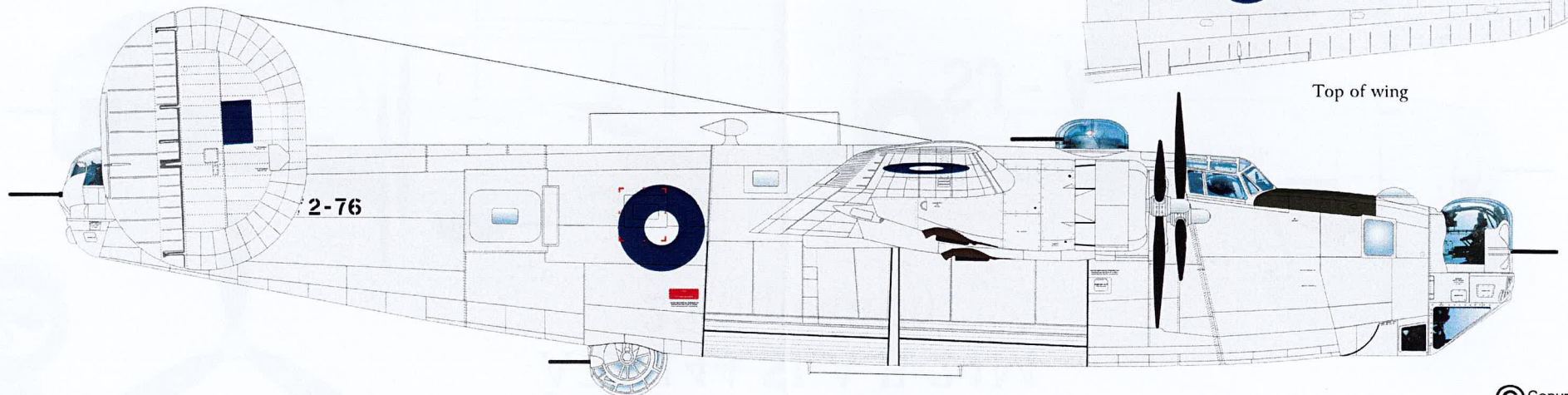



Propeller



Royal Australian Air Force A72-144 SJ-A B-24M 25 Squadron



Use swan tail marking A

A72-144

SJ - A



Bottom of wing

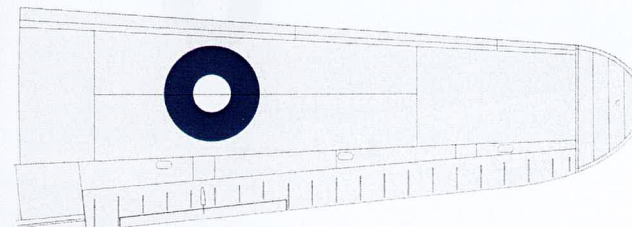
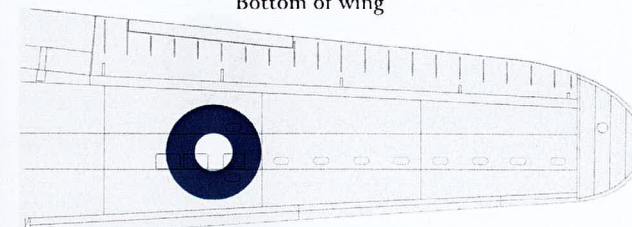

Top of wing

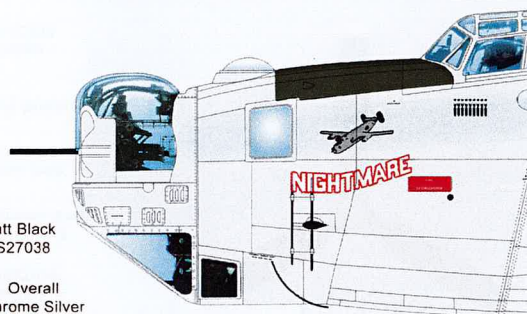

SJ-A A72-144 B-24M-1-CO 44-41831
Also Carried the Nose art names of
"ELIZABETH ANN"
"NIPPONS NIGHMARE"
"NIGHTMARE"
AND
"NELLIES NIGHTMARE"



This data plate was painted over by the Nose art.

AUSTRALIA

**U.S ARMY B-24M-1-CO
AIR FORCES SERIAL 44-41831**
SUITABLE FOR AROMATICS
SERVICE THIS AIRCRAFT WITH 100
OCTANE FUEL IF NOT AVAILABLE
T.O.08-5-1 WILL BE CONSULTED
FOR EMERGENCY ACTION

EXCEPT A-F-C-E

-  Matt Black FS27038
-  Overall Chrome Silver
-  Olive Drab FS34087
-  Dark Brown
-  Yellow FS-33538

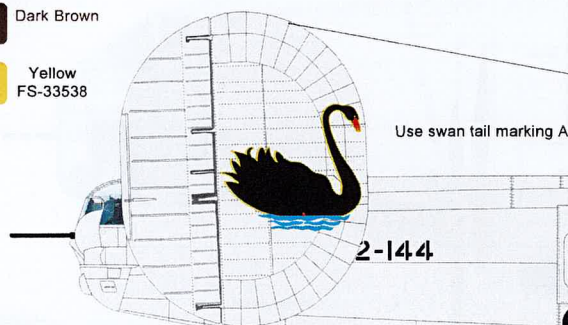

Use swan tail marking A

2-144

SJ - A

Note:

When these were delivered to the RAAF they were covered in data.

As time went on, not all the data was applied. For Data Placement see Data Placement sheets.



Royal Australian Air Force

A72-152 SJ-F B-24L

25 Squadron

NOTE:
 In the image Below it shows
 That A72-152 had 4 bomb markings painted on her.
 By the end of here time records show that she had
 ended up with 6 bomb markings.

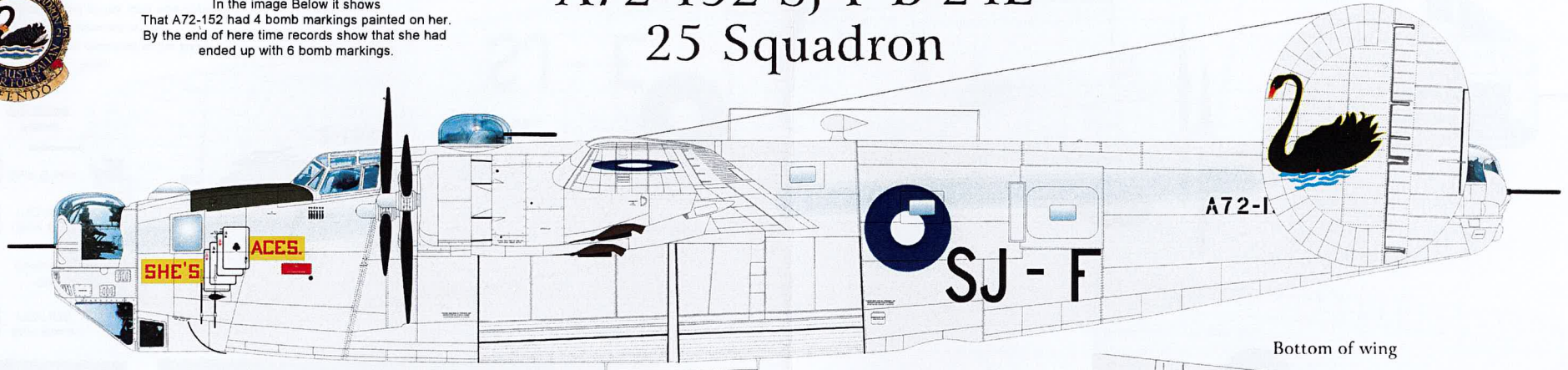

Bottom of wing

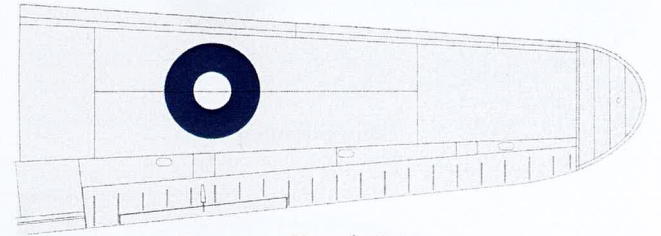
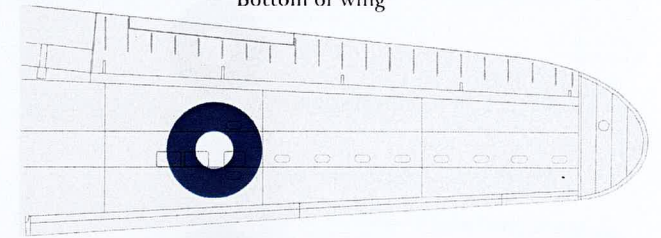

Top of wing

- Matt Black
FS27038
- Overall
Chrome Silver
- Olive Drab
FS34087
- Dark Brown
- Yellow
FS-33538

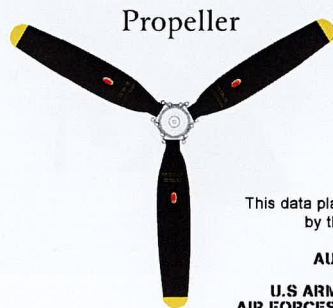

This data plate was painted over
 by the Nose art.

AUSTRALIA
U.S ARMY B-24L-5-C0
AIR FORCES SERIAL. 44-41518
 SUITABLE FOR AROMATICS
 SERVICE THIS AIRCRAFT WITH 100
 OCTANE FUEL IF NOT AVAILBLE
 T.O.08-5-1 WILL BE CONSULTED
 FOR EMERGENCY ACTION
 EXCEPT A.F.C.E



FRONT LEFT: PL BOB GREEN, W.O. 1; PL ARTHUR WHEELER; PL WYLLIE BERNINGTON, A.C. 1; PL NORMAN GILL; PL FRANK NORTH; CAPTAIN
 FORSYTH EVANS, A.C. 1; PL ANDY LAYLA, W.O. 1; PL PAT WELSH, W.O. 1; PL NORMAN BERRY; CAPTAIN; PL BILL POOLE, W.O. 1; PL FRANK MERRY, W.O. 1
 PL FRANK WOODS; CREW: 2; SERGEANT; CANTONER, W.O. 1; 1948

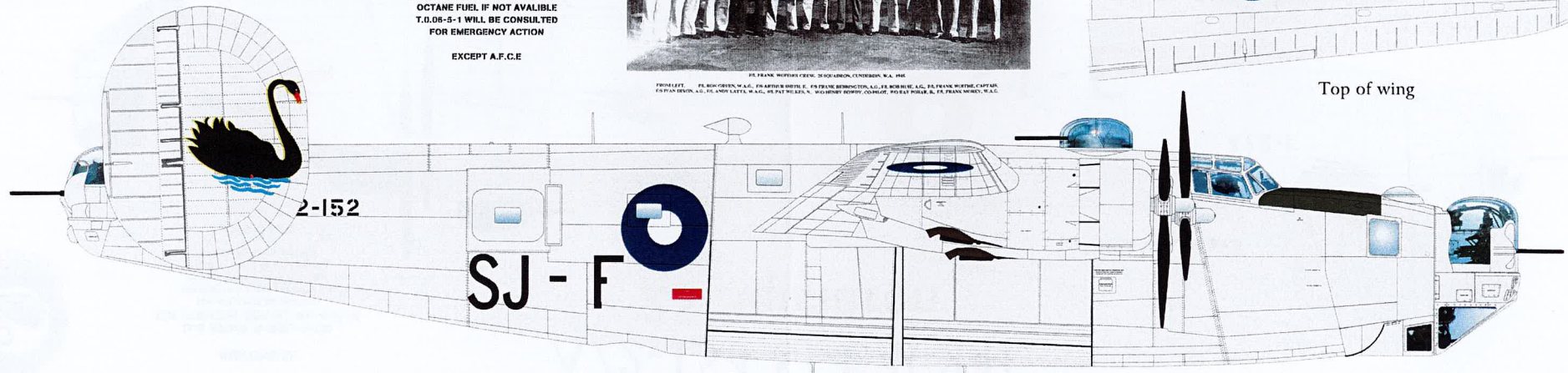



Royal Australian Air Force A72-154 SJ-E B-24L 25 Squadron

AUSTRALIA
U.S. ARMY B-24L-5-CO
AIR FORCES SERIAL 44-41518
- SUITABLE FOR AROMATICS
SERVICE THIS AIRCRAFT WITH 100
OCTANE FUEL, IF NOT AVAILABLE
T.O.06-5-1 WILL BE CONSULTED
FOR EMERGENCY ACTION

EXCEPT A.F.C.E

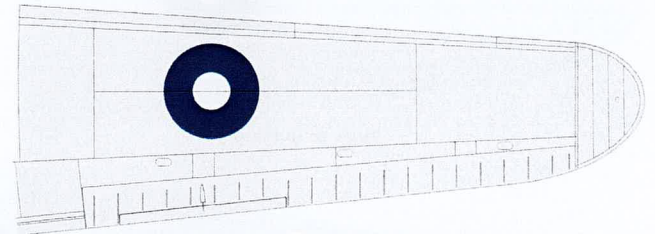
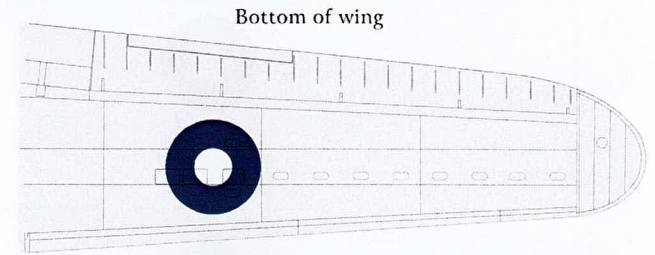
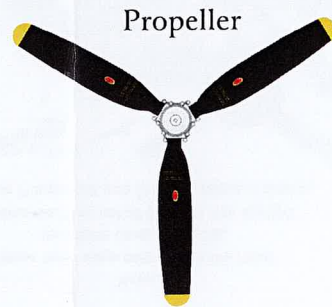
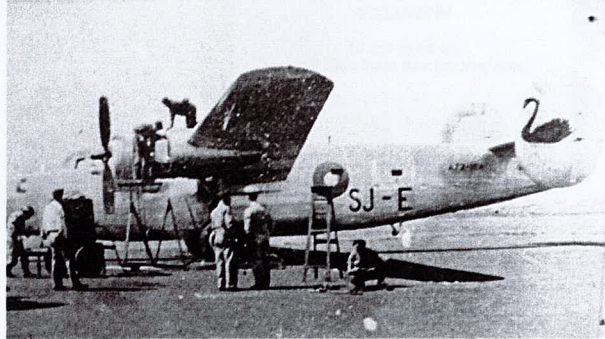
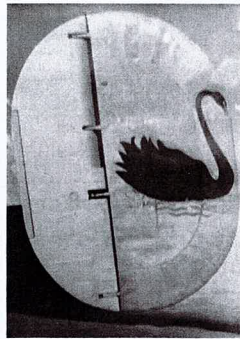
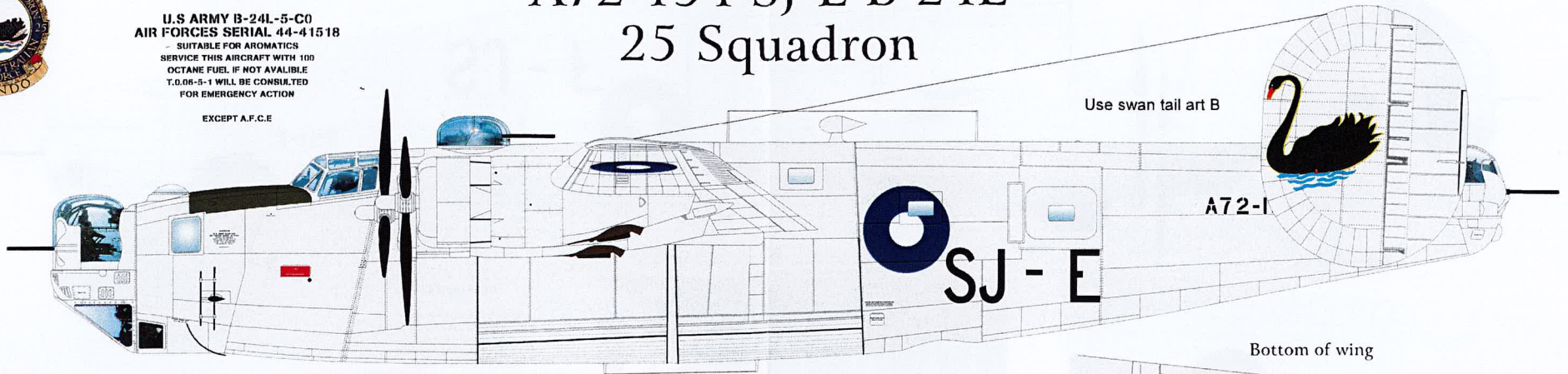

-  Matt Black
FS27038
-  Overall
Chrome Silver
-  Olive Drab
FS34087
-  Dark Brown
-  Yellow
FS-33538

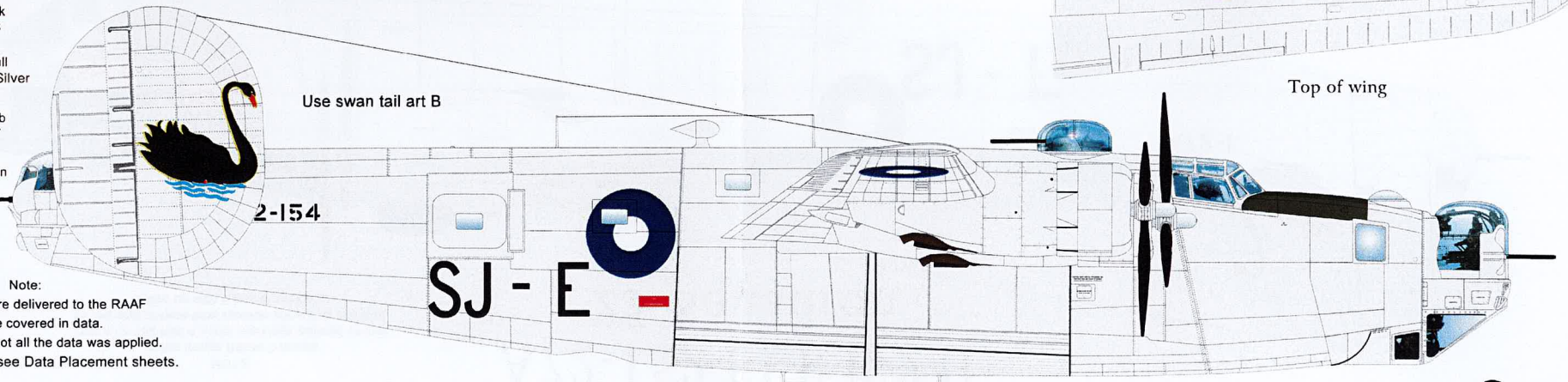

Note:
When these were delivered to the RAAF
they were covered in data.
As time went on, not all the data was applied.
For Data Placement see Data Placement sheets.

Royal Australian Air Force B-24I/J/L/M Liberator's Data Placement



Early Days

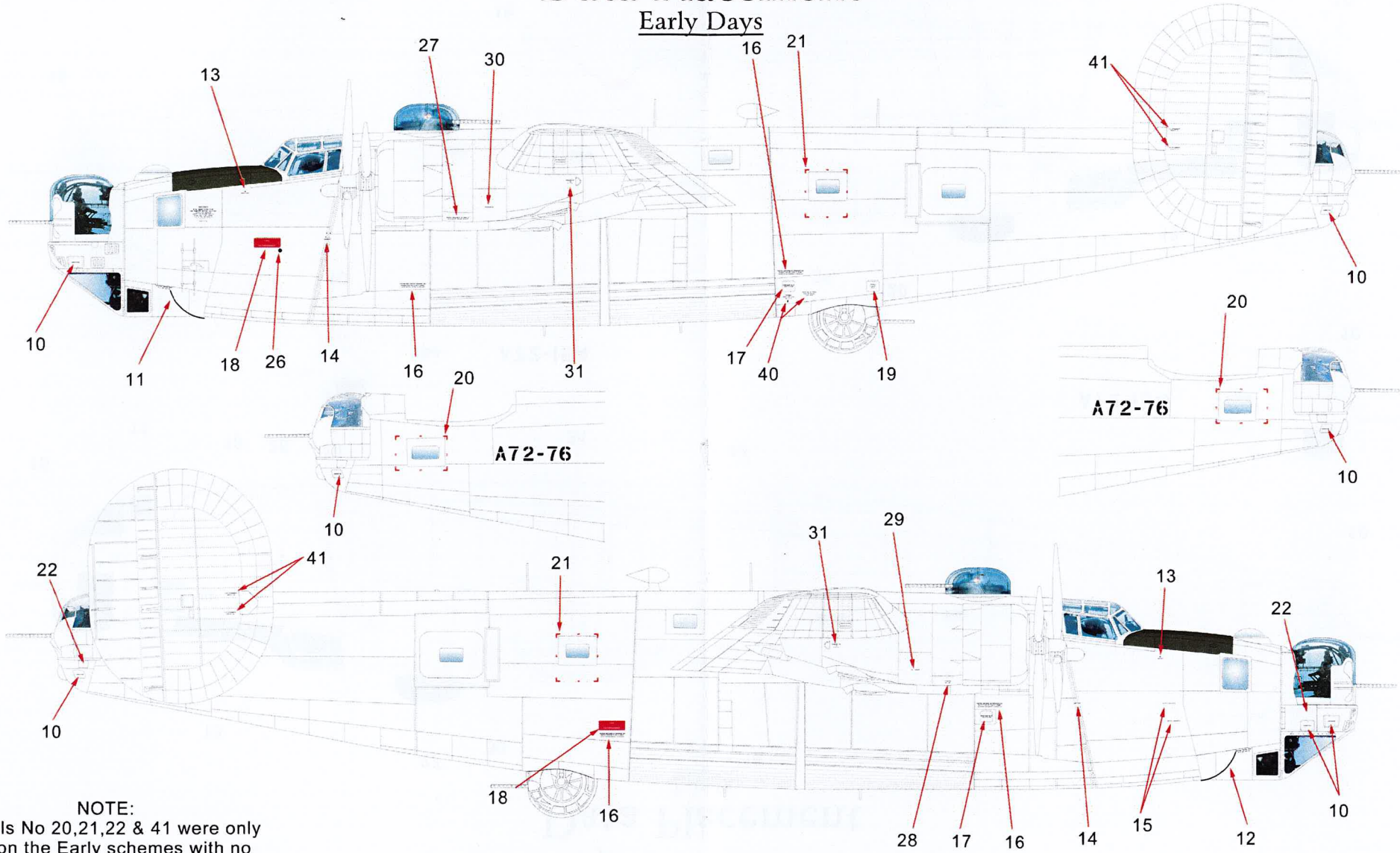

NOTE:
Decals No 20,21,22 & 41 were only
use on the Early schemes with no
Swan on the tail.

RDS-306 RAAF 25 Sqn B-24J/L/M Liberator

Royal Australian Air Force B-24I/J/L/M Liberator's Data Placement

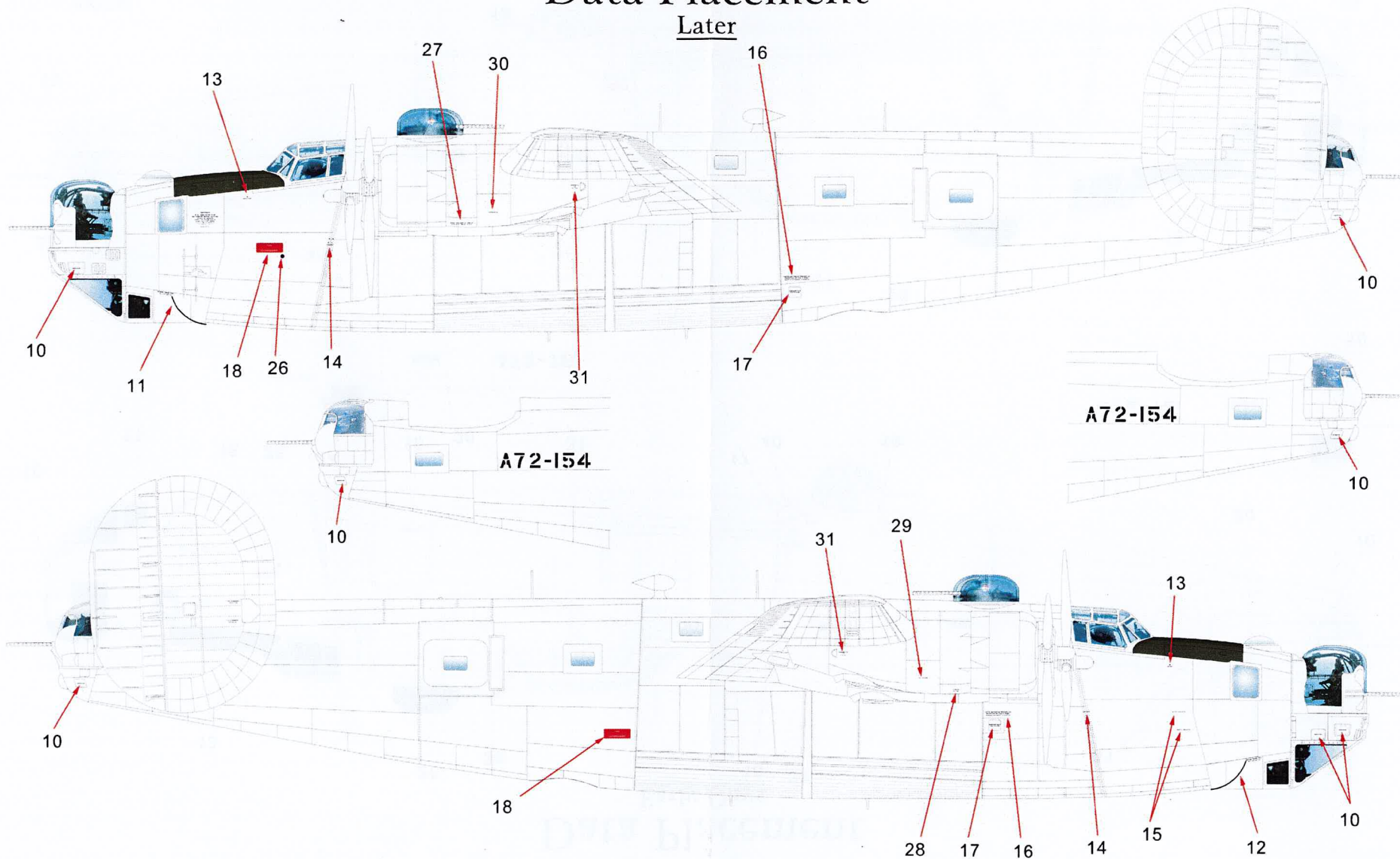

Royal Australian Air Force B-24J/I/M Liberator Wing Data Placement

NOTE:2
All Data goes in the same place
on the starboard side wing.

Upper Port wing

Note 3
Decals 28 & 29 go on inside of engine cells on the port wing
and on the outside of the engine cells on the starboard wing.

Note 4
Decals 27 & 30 go on outside of engine cells on the port wing
and on the inside of the engine cells on the starboard wing.

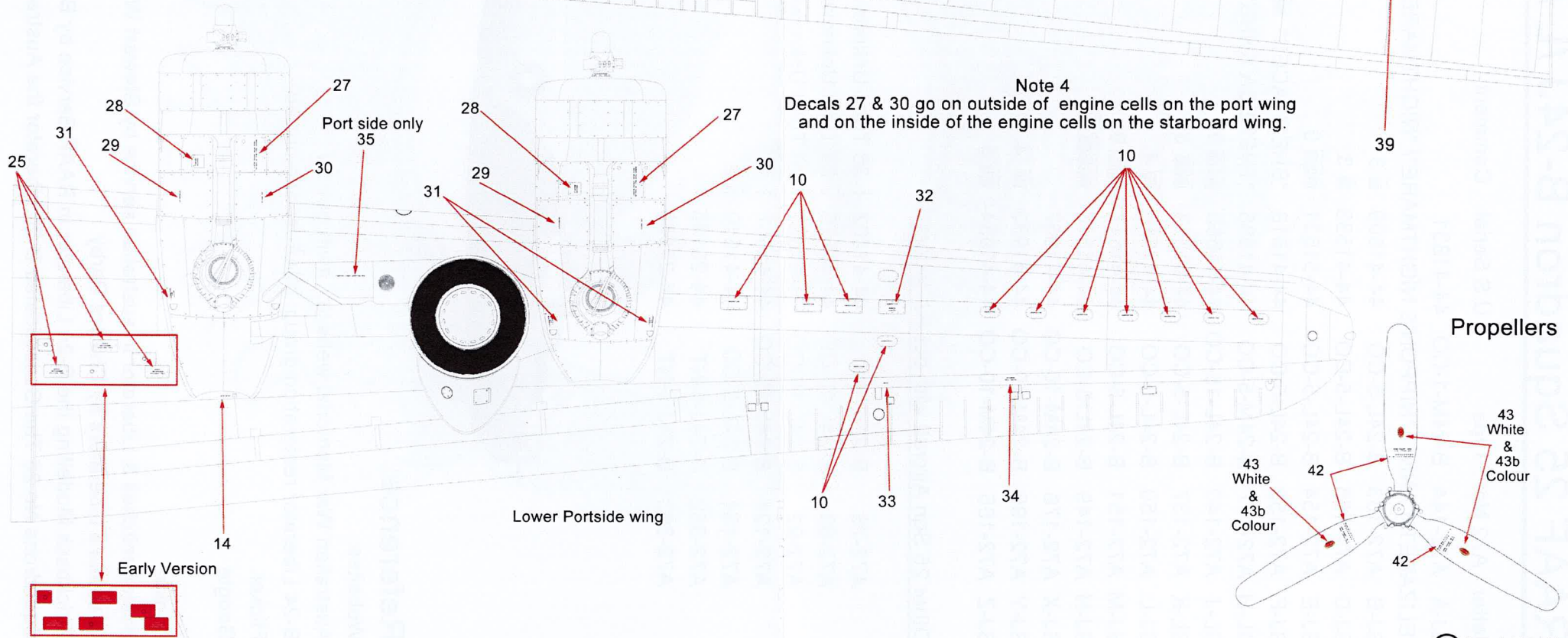

23 / 24
Port side Starboard side

RDS-306 RAAF 25 Sqn B-24J/L/M Liberator

RAAF 25 Squadron B-24J /L /M Aircraft serials

letter	A72 No	Type	U.S Serial	Comment
SJ-A	A72-144	B-24M-1-CO	44-41831	"ELIZABETH ANN" / "NIPPON'S NIGHTMARE" / "NIGHTMARE" / "NELLIES NIGHTMARE" / 8
SJ-B	A72-133	B-24L-5-CO	44-41509	3
SJ-D	A72-156	B-24L-5-CO	44-41533	3
SJ-E	A72-154	B-24L-5-CO	44-51531	9
SJ-F	A72-152	B-24L-5-CO	44-41518	"SHE'S ACES" 6
SL-H	A72-147	B-24M-5-CO	44-41885	"THERESA ANNE" 9
SL-J	A72-140	B-24L-15-CO	44-41665	9
SL-K	A72-137	B-24L-5-CO	44-41513	8
SJ-L	A72-150	B-24L-5-CO	44-41516	4
SJ-M	A72-151	B-24L-5-CO	44-41517	9
SJ-N	A72-149	B-24L-5-CO	44-41515	12
SJ-X	A72-178	B-24M-10-CO	44-41967	
SJ-Y	A72-190	B-24M-10-CO	44-41983	4
SJ-Z	A72-165	B-24M-10-CO	44-41954	5

Other 25 Sqn Aircraft with out SJ- letters

A72-76	B-24I-1-CO	44-41402	i	36 Total Unknown with which Sqn
A72-89	B-24L-10-CO	44-41575	i	24 Total Unknown with which Sqn
A72-92	B-24L-10-CO	44-41581	i	25 Total Unknown with which Sqn
A72-124	B-24L-15-CO	44-41657	i	1
A72-134	B-24L-5-CO	44-41510	ii	2
A72-352	B-24J-5-NT	44-28135		
A72-353	B-24J-5-NT	44-28133		

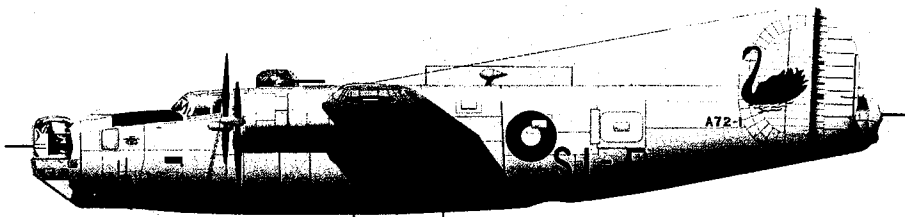

Reference:

Websites:

Australian War Memorial website: awm.gov.au

B-24 Liberator restoration group: b24Australia.org.au

Flicker.

Google

Books:

Boston, Mitchell & Liberator in Australian service by Stewart Wilson

Australia's Liberators by Charles Darby

Strickback Modelling the B-24 Liberator in RAAF Service by Bob Livingstone

Squadrons No.28 The Consolidated B-24 Liberator the Australians by Phil h. Listemann

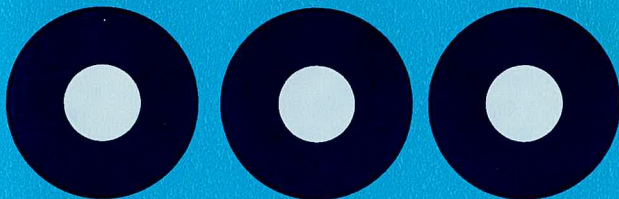
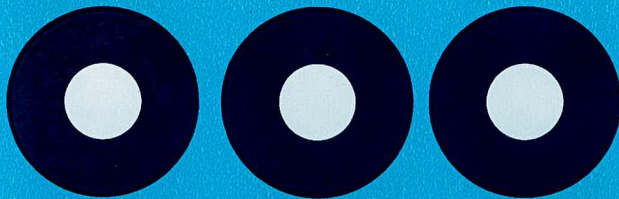

PRINTED AND DESIGNED BY
SERPENT GRAPHICS AUSTRALIA
AUSTRALIAN MADE AND OWNED
Copyright 2024 ©



B

42

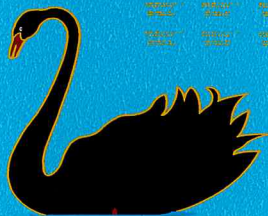

A

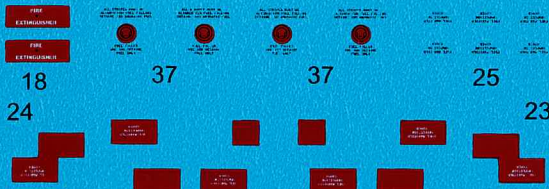

SJ - SJ -



NELLIES NIGHTMARE

NIGHTMARE

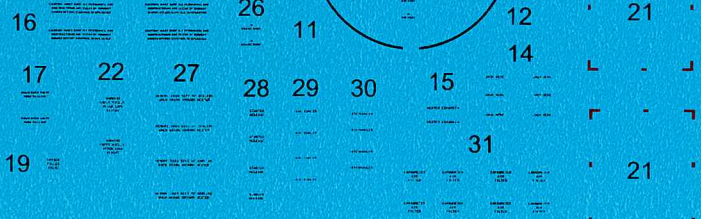

RDS-306 RAAF 25 Sqn B-24J/L/M Liberators 1945 - 1946

A72-76 A72-89 A72-92 A72-124 A72-133 A72-134
A72-76 A72-89 A72-92 A72-124 A72-133 A72-134

A72-137 A72-140 A72-144 A72-147 A72-149
A72-137 A72-140 A72-144 A72-147 A72-149

A72-150 A72-151 A72-152 A72-153 A72-154
A72-150 A72-151 A72-152 A72-153 A72-154

A72-156 A72-165 A72-178 A72-190 A72-352
A72-156 A72-165 A72-178 A72-190 A72-352

A72-353 A72-353 RDS-306 RAAF 25 Sqn B-24J/L/M Liberators 1945 - 1946

A B D E F H J K L M N X Y Z
A B D E F H J K L M N X Y Z

