

Border

# 二十八糎榴彈砲

IJA 28CM HOWITZER RUSSO-JAPANESE WAR 1905日露戦争

- MOST OF THE GEAR SETS CAN BE MOVED.
- THE BARREL MOVES IN THE SAME WAY AS THE REAL GUN.
- THE INSIDE OF THE BARREL USES A NEW MOLD PROCESSING TECHNOLOGY TO ACHIEVE SPIRAL RIFLING.

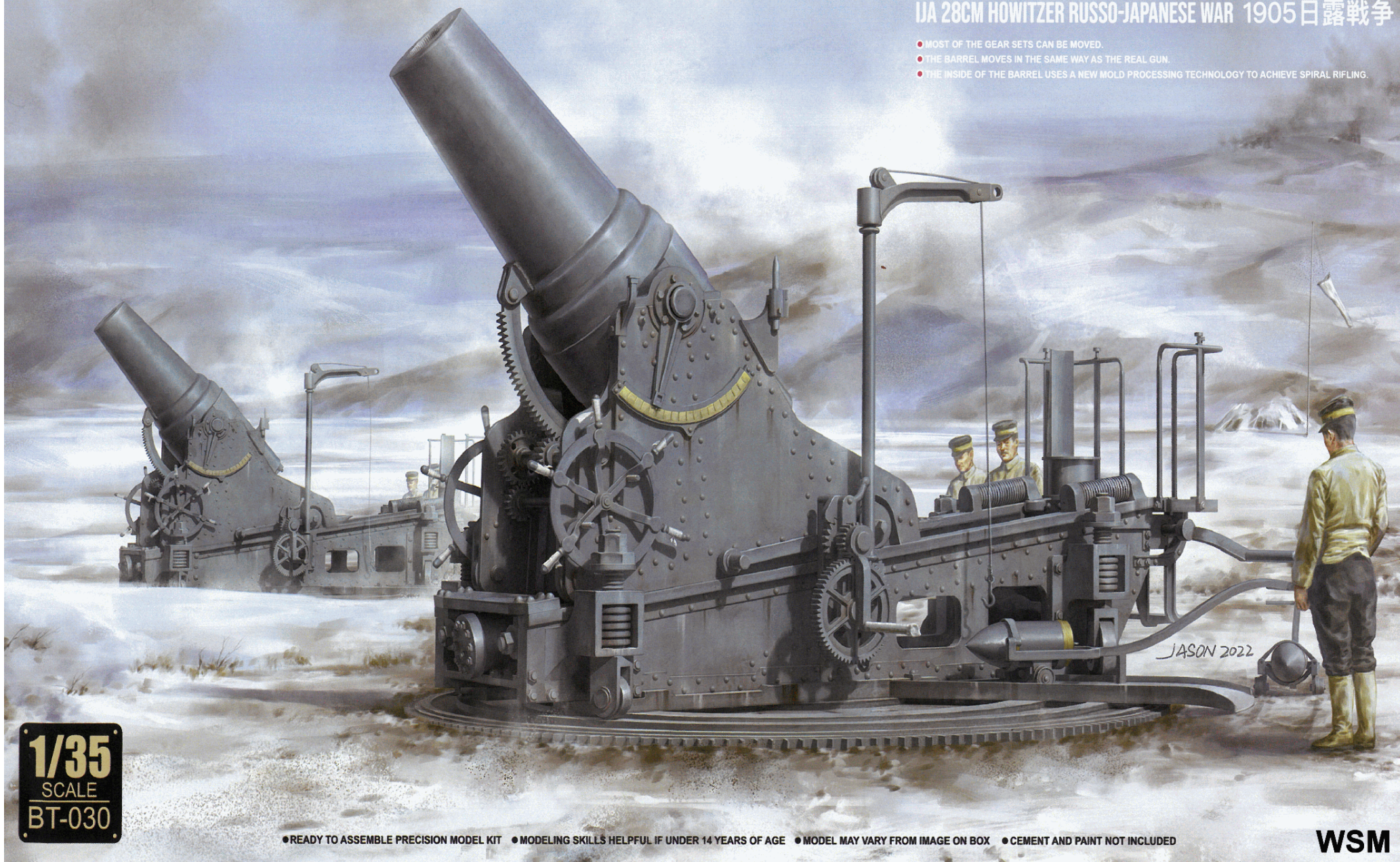

1/35  
SCALE  
BT-030

● READY TO ASSEMBLE PRECISION MODEL KIT ● MODELING SKILLS HELPFUL IF UNDER 14 YEARS OF AGE ● MODEL MAY VARY FROM IMAGE ON BOX ● CEMENT AND PAINT NOT INCLUDED

WSM



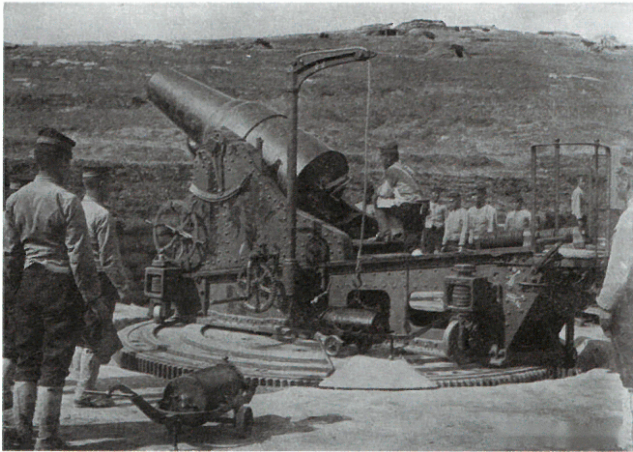
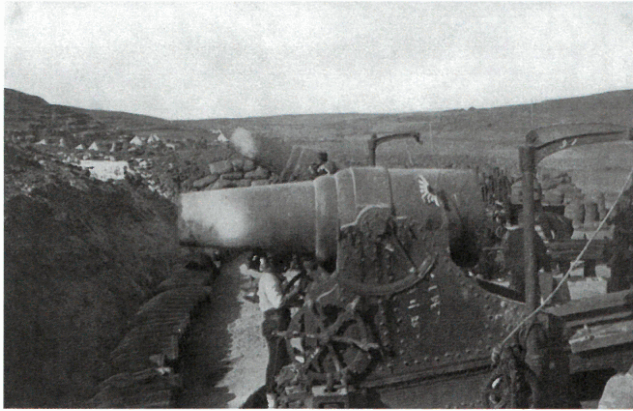

## History | 历史介绍

## IJA 28cm Howitzer Russo-Japanese war

The Japanese 280mm howitzers were copied from Italy. The Osaka Artillery Factory made a trial production of the 280mm howitzers in 1884 (Meiji 17), and in 1886 (Meiji 19) they were test fired at Nobuta Mountain in Osaka Prefecture with very good results. The Krupp Company also made a 28-percent mortar modeled after the same gun and sold it to the Russians (about 10 of them in the Russo-Japanese War). Both guns had the same general elements and were rear-loaded, using a boom to raise the shells and charge packs to a horizontal height and pressing the shells into the chamber by hand, making the firing speed much higher. The biggest difference between the two guns was that the Japanese 280mm howitzer had a left-handed rifling, while the Krupp-made one was the opposite. This gun proved decisive in both the Japanese capture of Hill 203 and the destruction of Russian ships in the harbor. Subsequently, the 280mm gun team was assigned to the Fourth Army and participated in the Battle of Fengtian.

日本的280mm榴弹炮是仿制自意大利，1884年（明治17年）大阪炮兵工厂仿照意大利280mm榴弹炮进行试制、1886年（明治19年）于大阪府信太山进行了试射并且取得了非常良好的效果。1887年（明治20年）正式投入批量生产。而克虏伯公司也模仿同一火炮制造了28厘米臼炮，并卖给了俄国人（日俄战争大约有10门）。这两种炮大体诸元是相同的，装填方式为后装式，使用吊臂将炮弹和药包提升到水平高度，使用人工将炮弹压入膛中，使得发射速度大大提高。两种火炮最大的区别是日本280mm榴弹炮膛线是左旋的，克虏伯造的与之相反。事实证明，此炮无论在日军占领203高地，还是摧毁港内俄舰上，都起到了决定性的作用。其后，280mm弹炮队又配属给第四军，参加了奉天会战。





# 部品圖 Parts

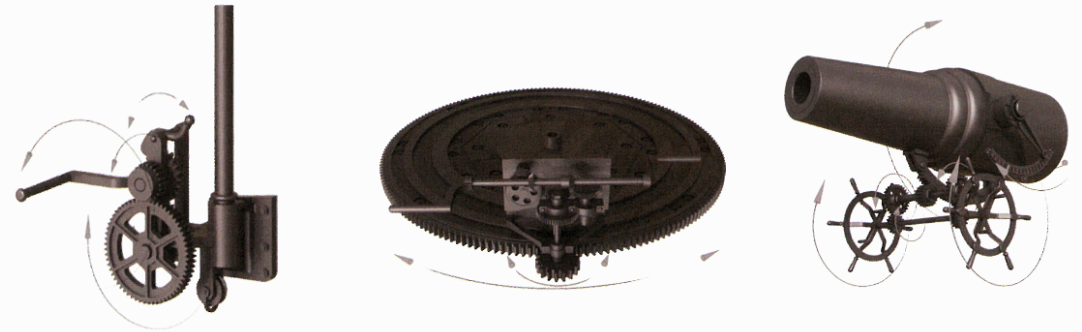
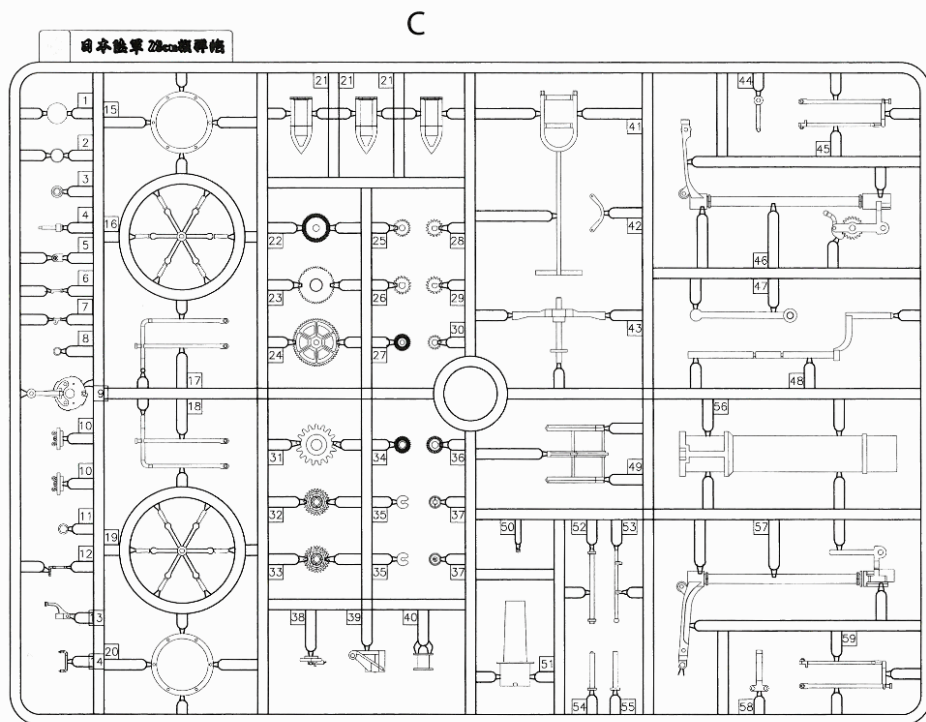
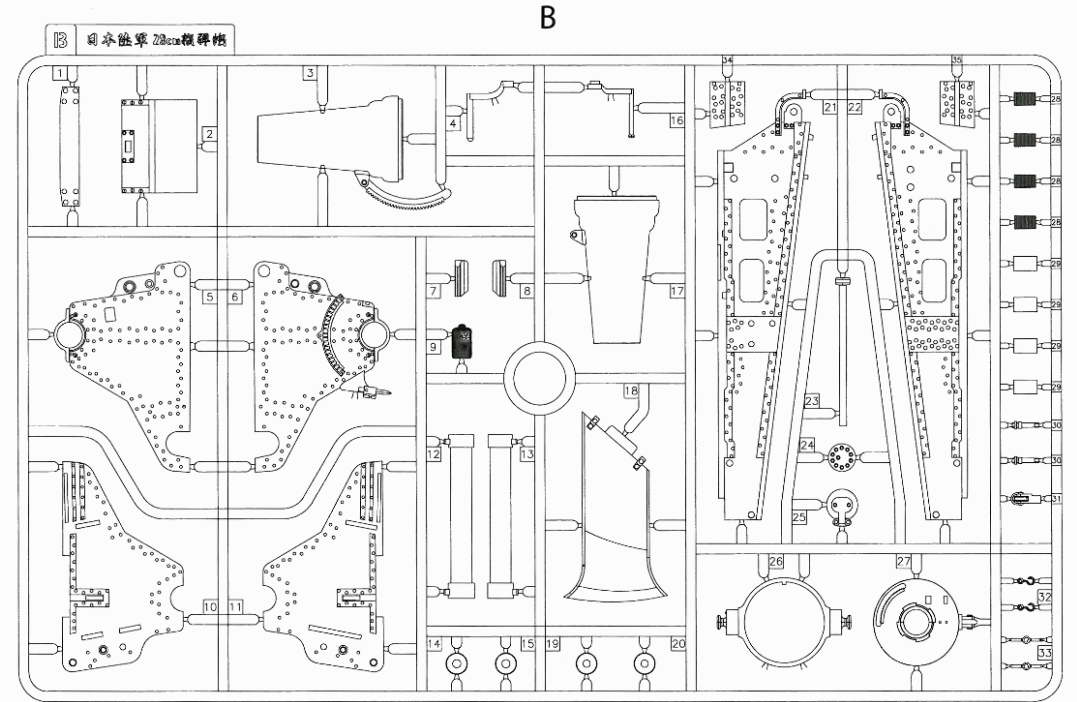
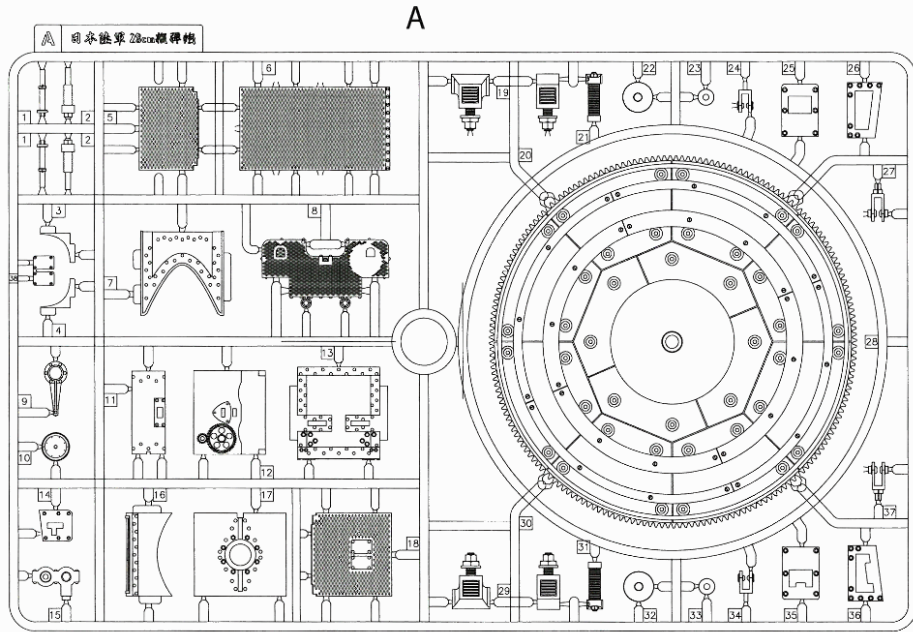

钢丝绳

Wire rope



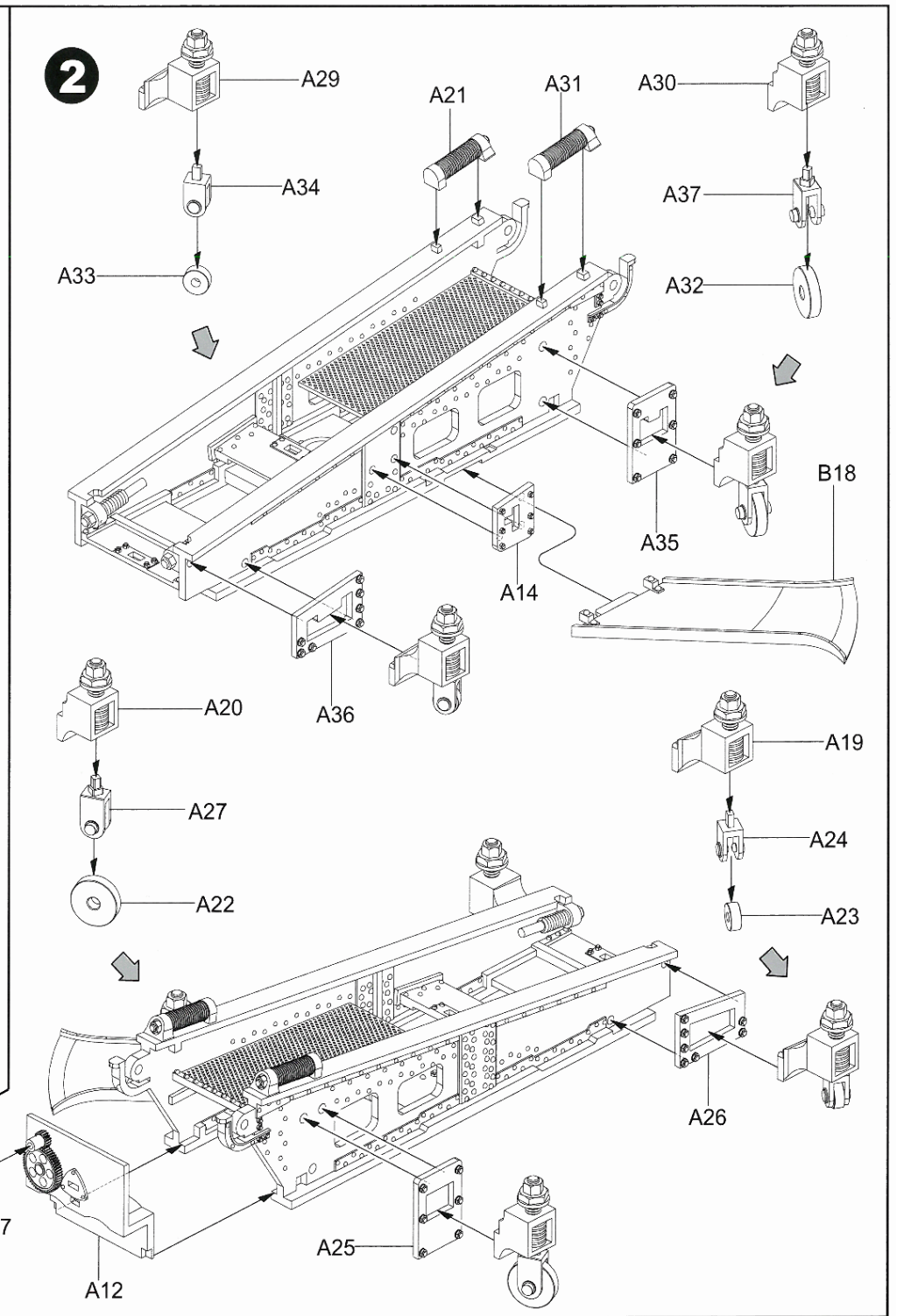
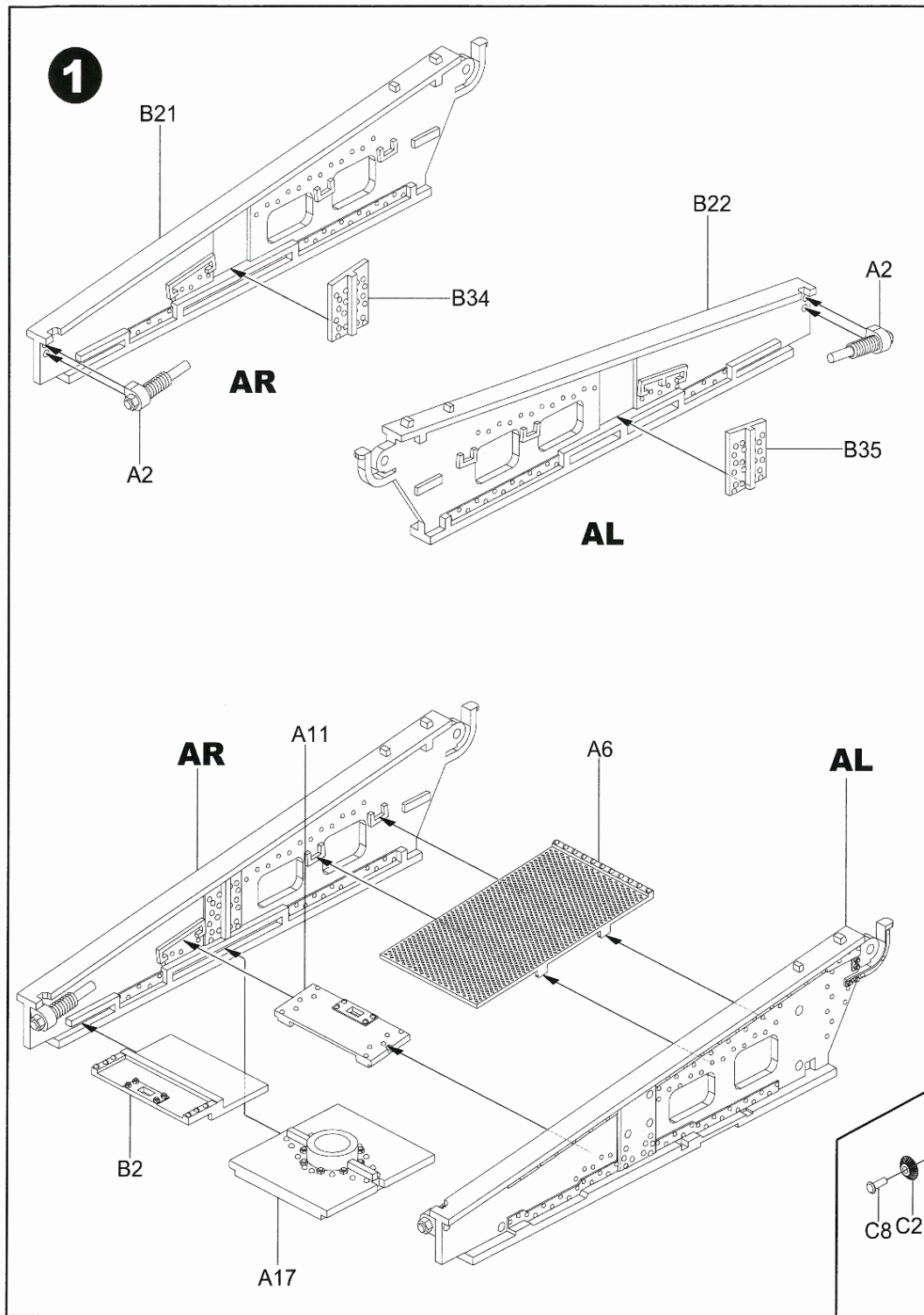



3

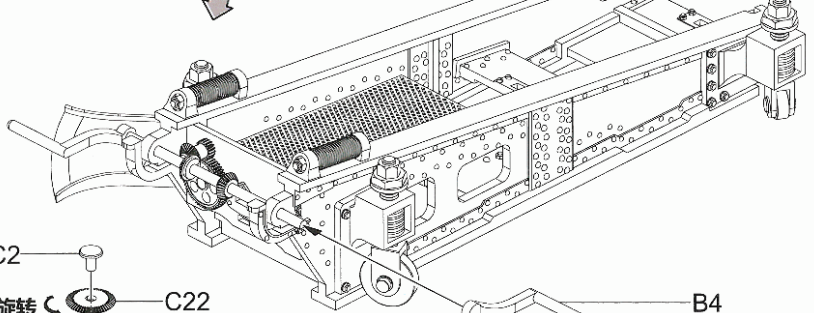
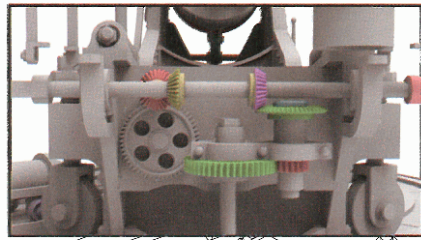
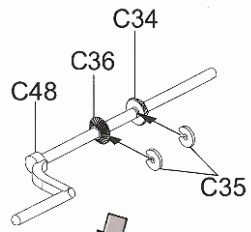

可旋转 C  
C2  
C22 不粘胶水  
Do not cement

可旋转 C  
C30 不粘胶水  
Do not cement

可旋转 C  
C23 不粘胶水  
Do not cement

可旋转 C  
C31 不粘胶水  
Do not cement

4

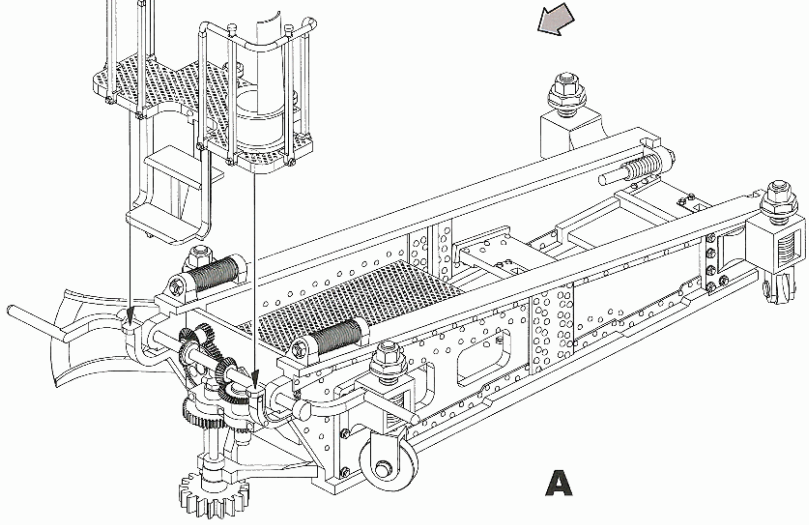
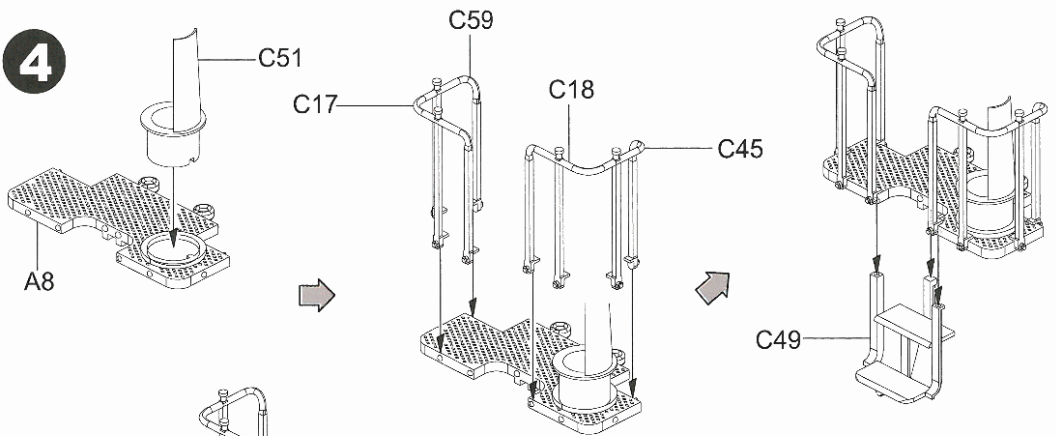

A

5

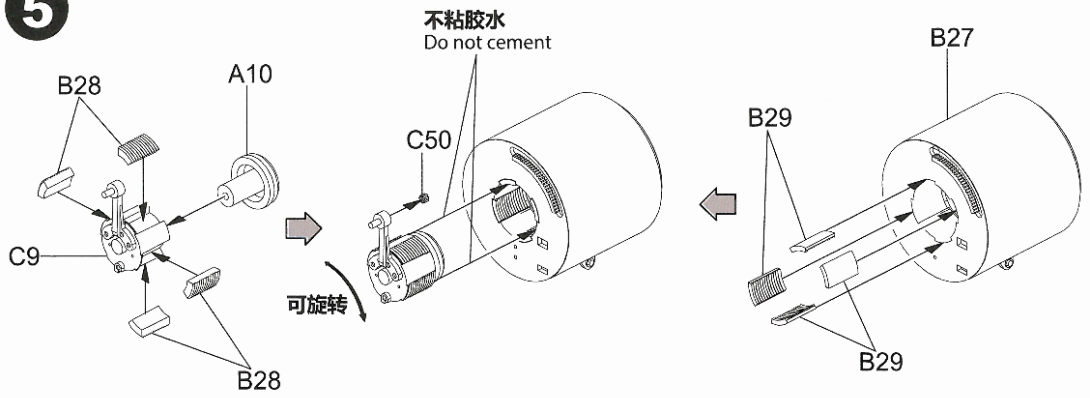

不粘胶水  
Do not cement

可旋转

**6**

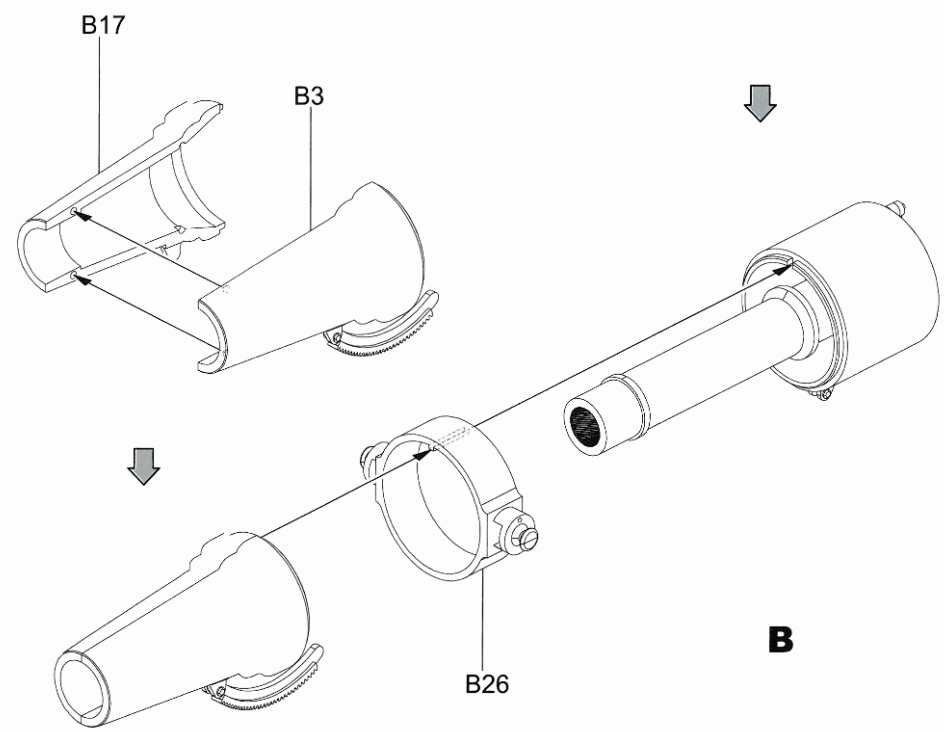
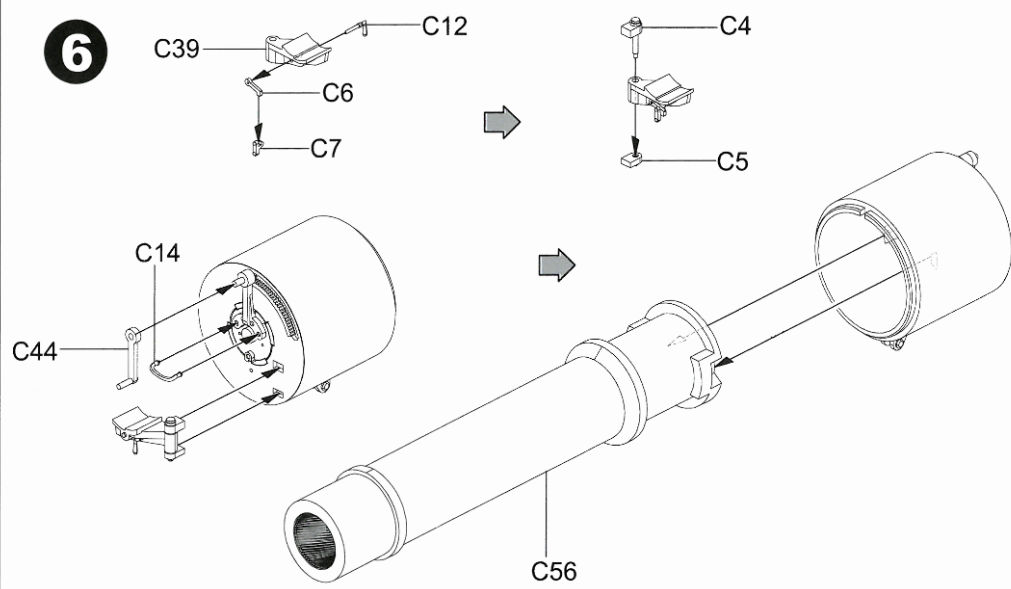

**B**

**7**

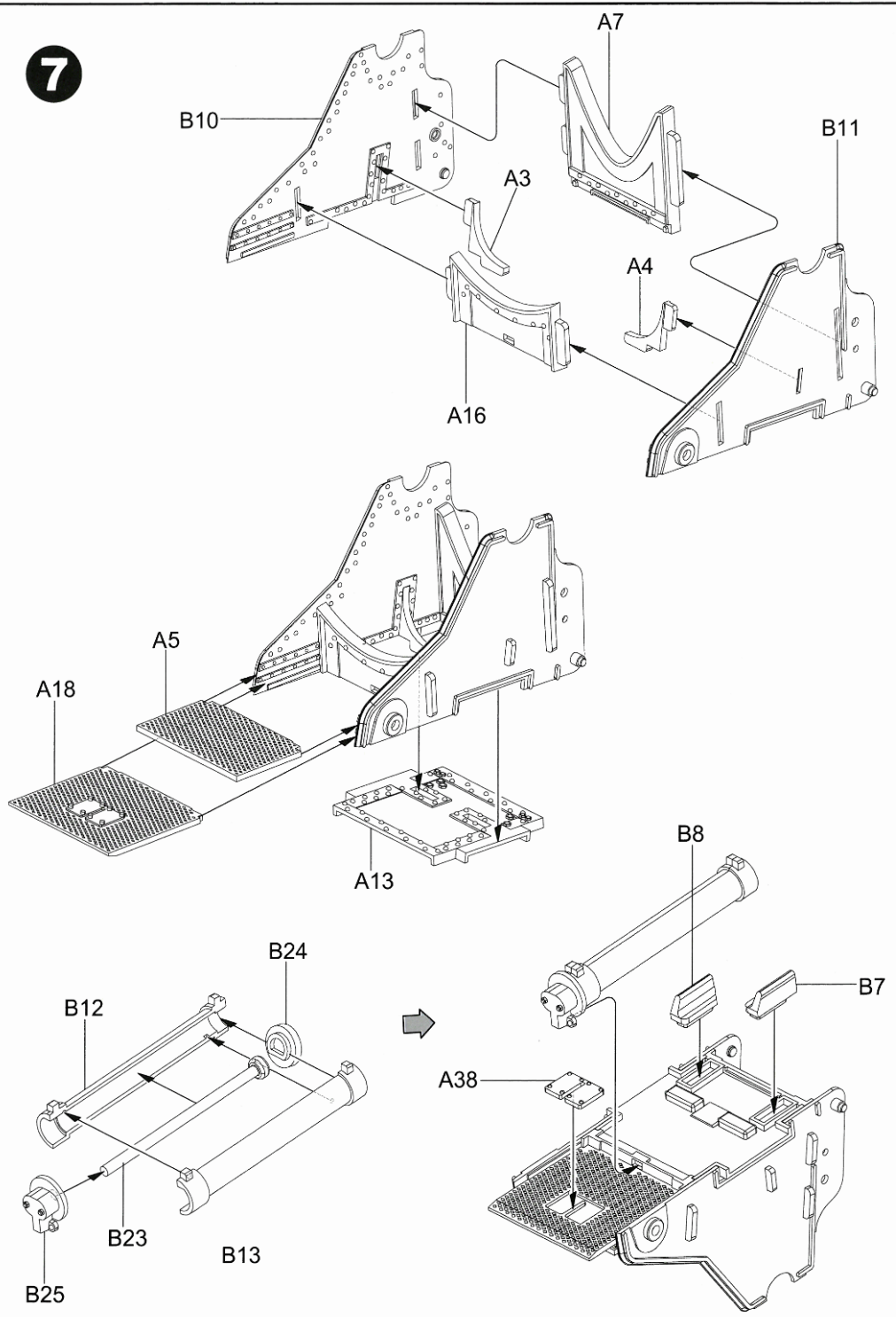

8

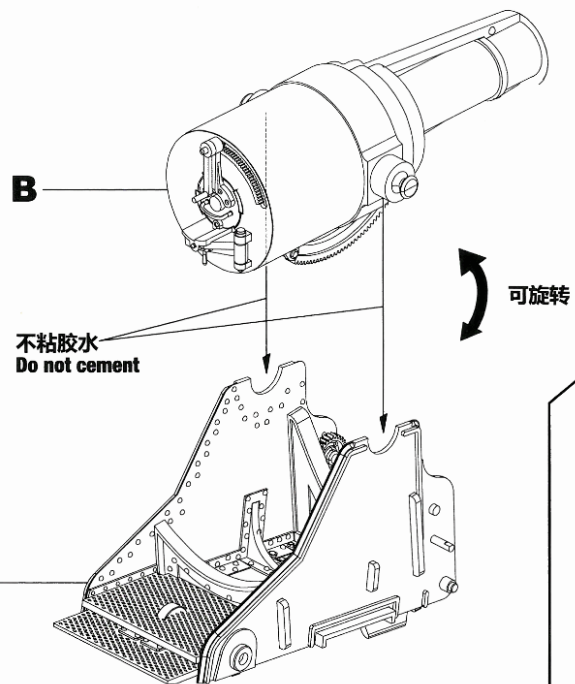
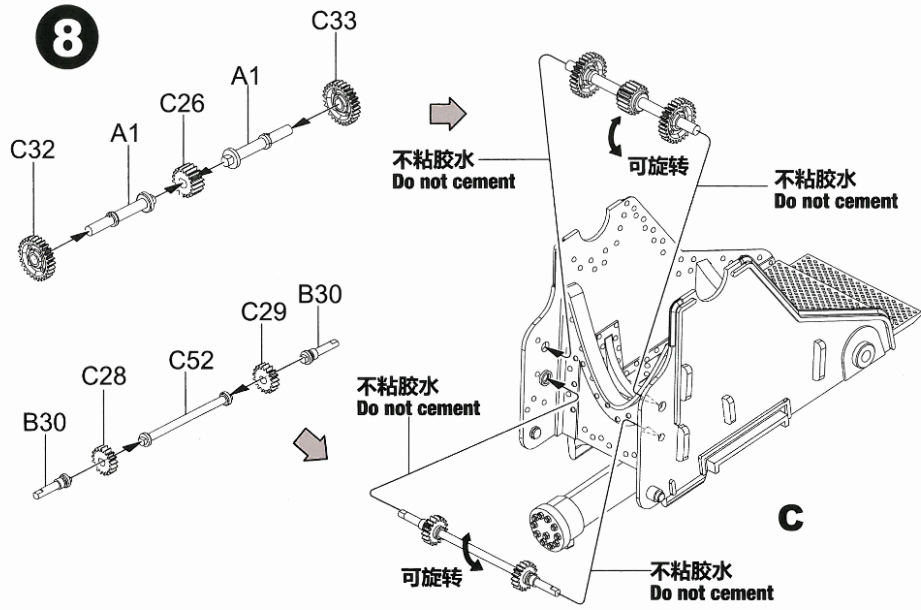

9

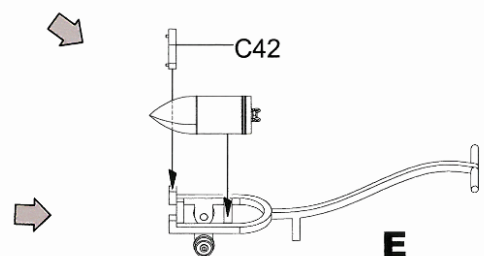
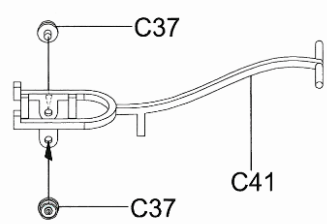
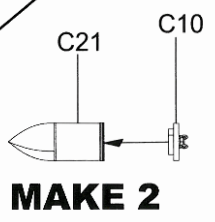
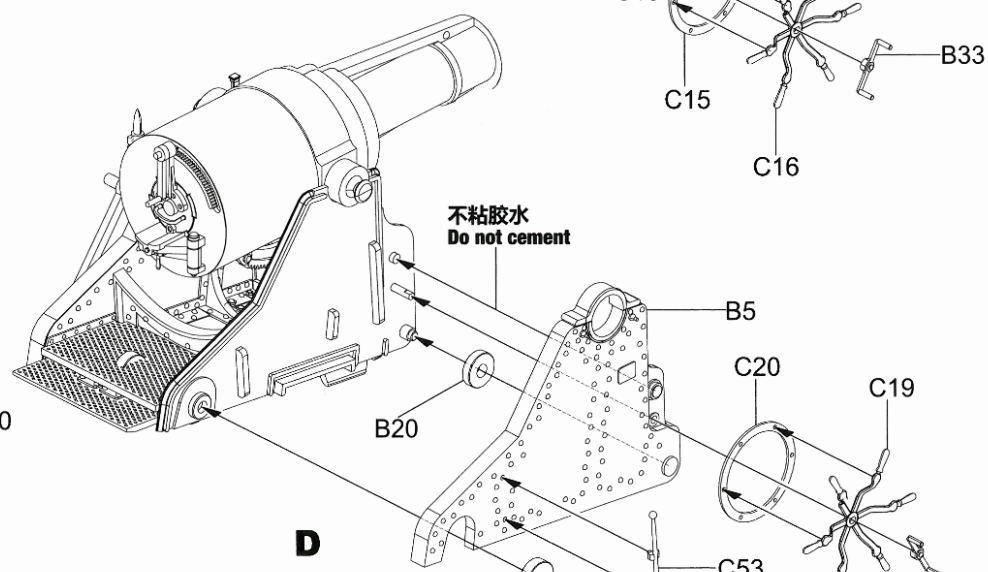
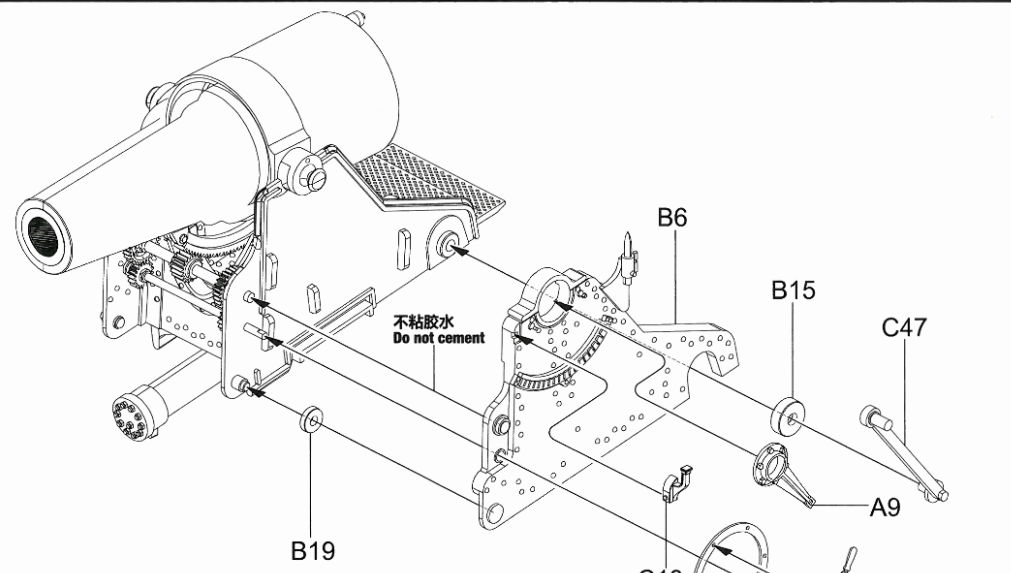



10

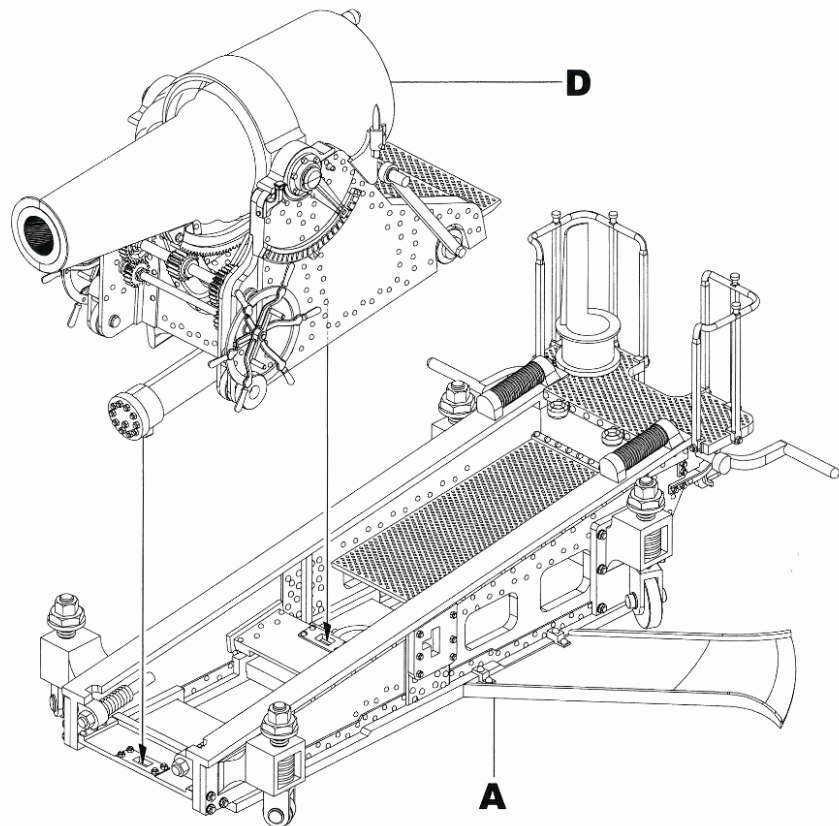

12

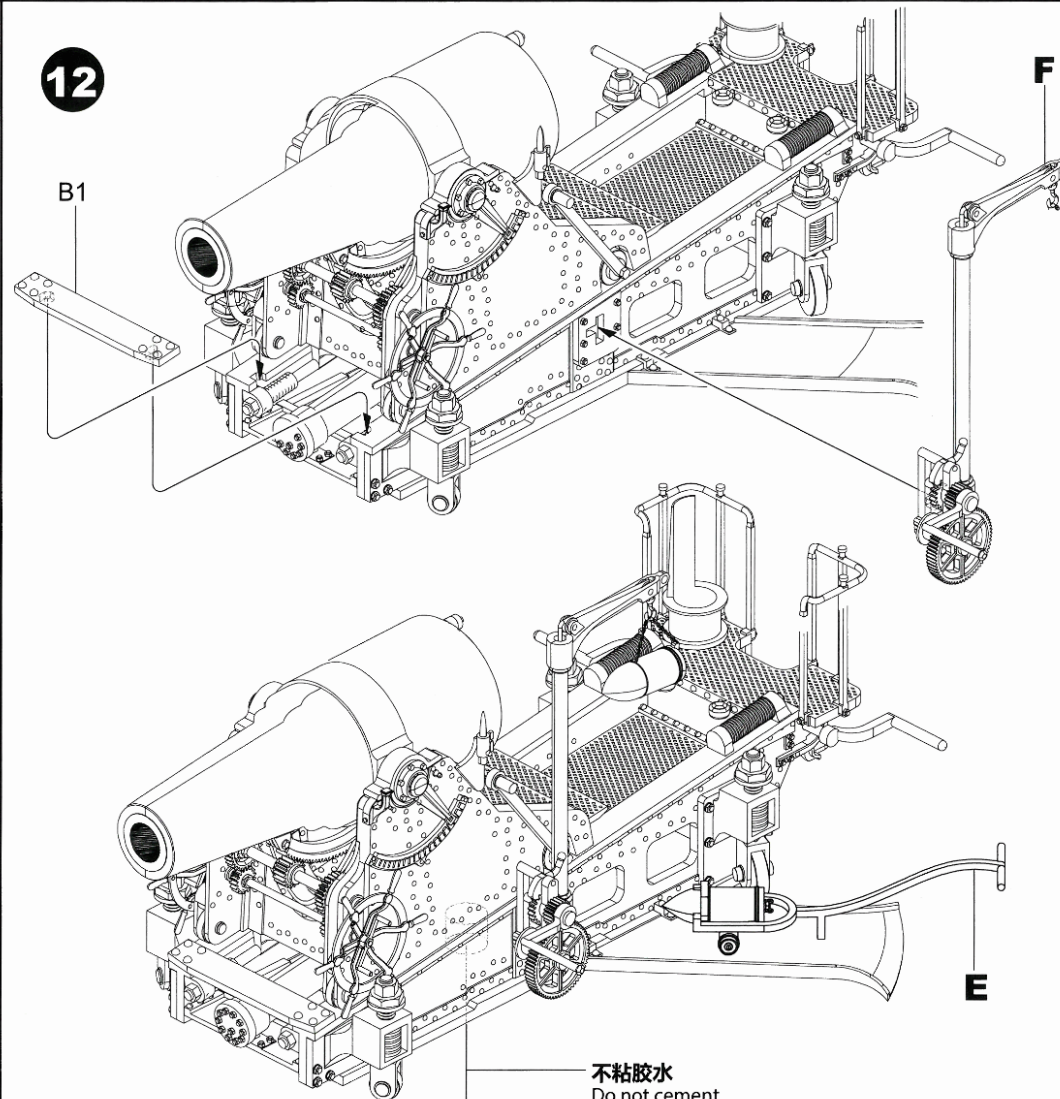

11

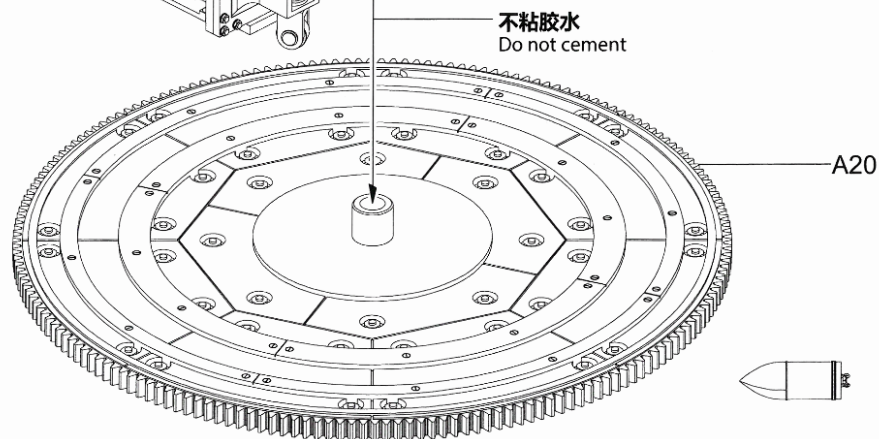
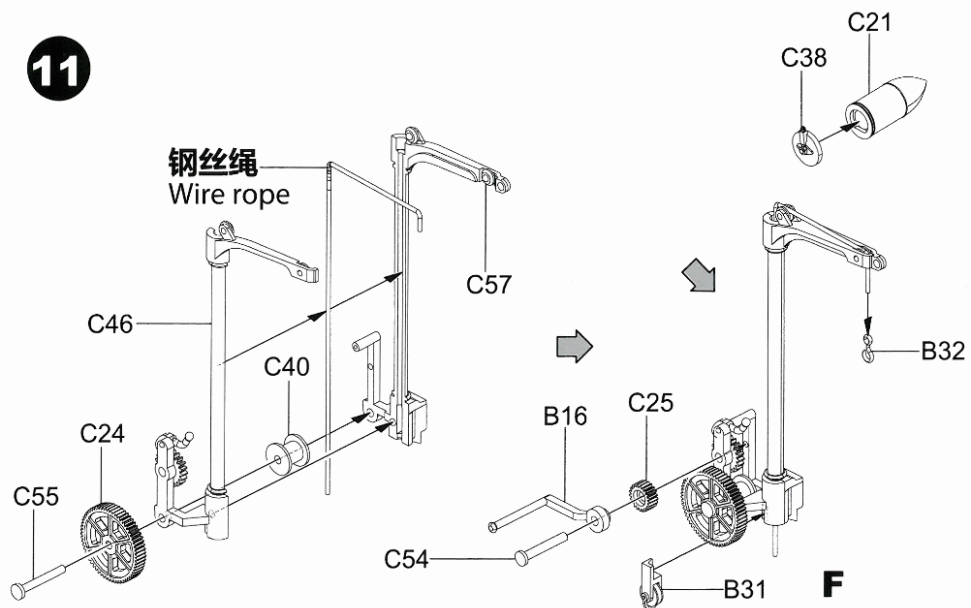



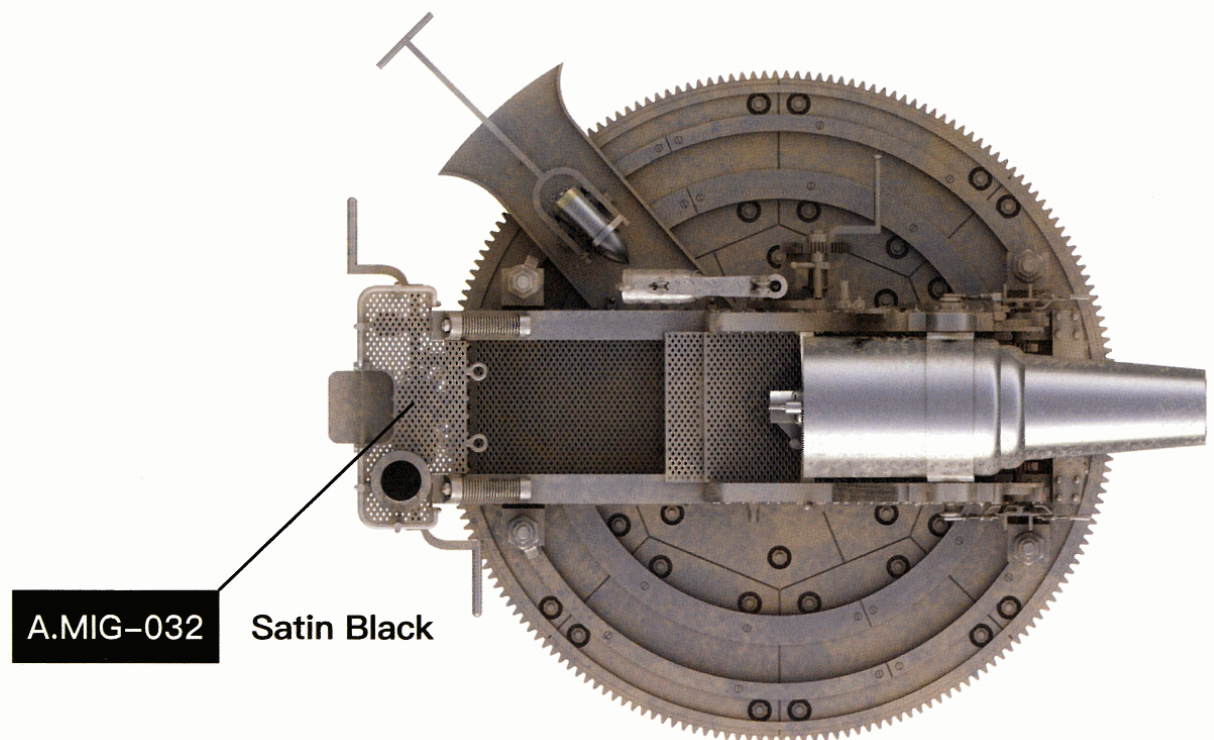
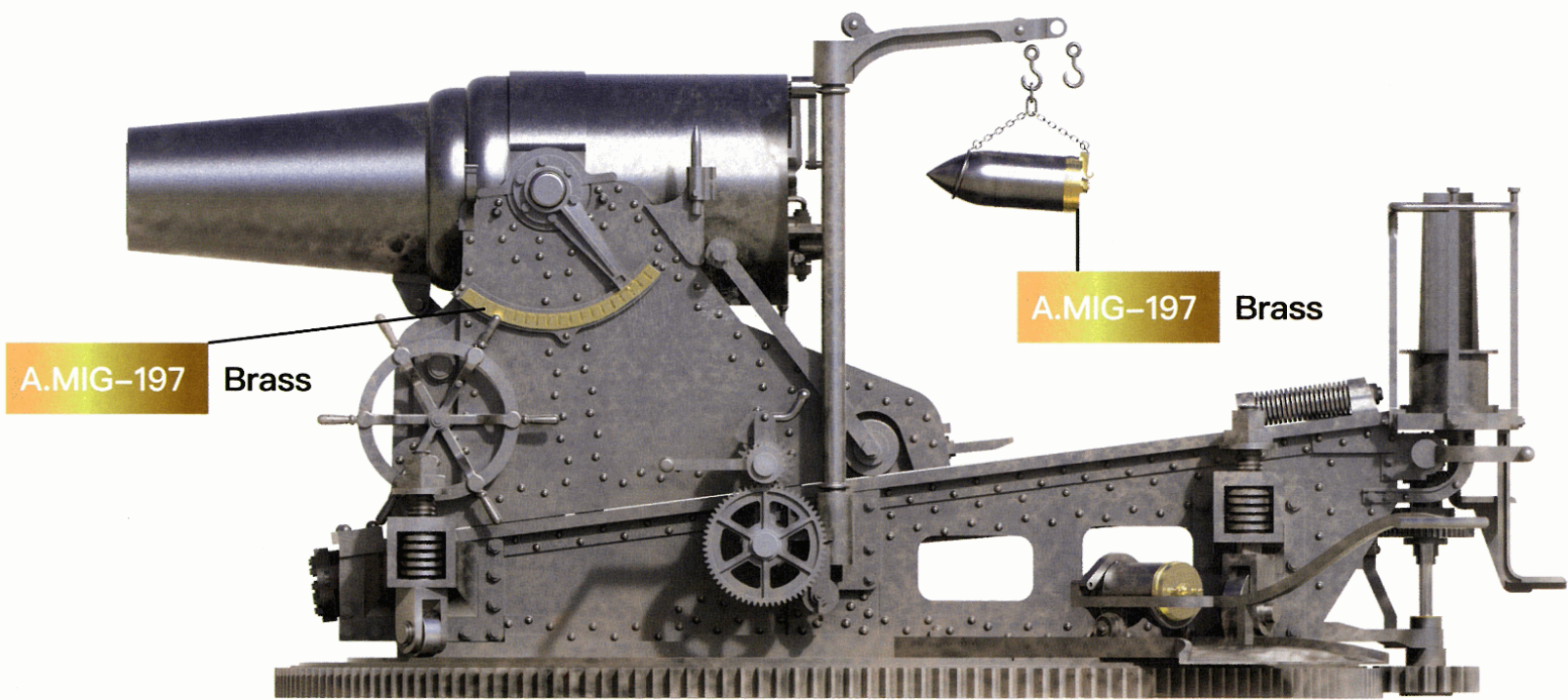



*Border*

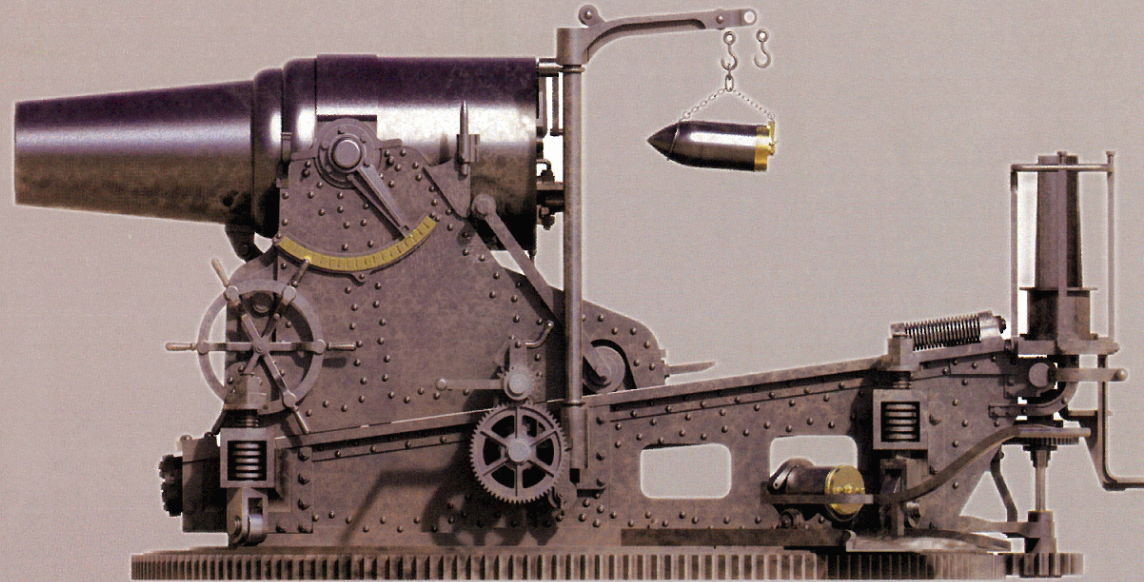

WWW.BORDERMODEL.COM