



Модель W.O.T. 8

Британский грузовой автомобиль II МВ

Одним из наиболее крупных поставщиков грузовых автомобилей для вооруженных сил Великобритании был британский филиал Форд Мотор Компани в Дагенхеме. Грузовики W.O.T. 8 4x4 грузоподъемностью 1,5 т строились в 1941-1942 г. и применялись в Северной Африке, Италии и Северо-Западной Европе между 1942 и 1945 годами. Они состояли на службе и после войны.

Всего было произведено около 2500 грузовиков W.O.T. 8.

Технические характеристики автомобиля W.O.T. 8

Грузоподъемность, т.....	1.5
Длина, мм.....	5220
Ширина, мм.....	2320
Высота, мм.....	2875
База, мм.....	3100
Двигатель.....	«Форд» V8, 3,62 л, 85 л.с.
Максимальная скорость, км/ч.....	75

ВНИМАНИЕ!

Перед сборкой внимательно прочитайте руководство по монтажу. Каждая деталь пронумерована. Соблюдать последовательность монтажа. Необходимые рабочие инструменты: нож и напильник для зачистки деталей; резиновая лента, клейкая лента и зажимы для сушки белья для прижимания склеиваемых деталей. Детали из пластика очистить в растворе мягкого моющего средства и высушить на воздухе для того, чтобы краска и переводные картинки лучше прилипали. Перед приклеиванием проверить, подходят ли детали: клей наносить экономно. Хром и краску удалить с поверхностей склеивания. Небольшие детали покрасить перед тем, как они будут удалены из рамок. Краску необходимо хорошо просушить, только после этого продолжать сборку. Каждую соответствующую переводную картинку отдельно вырезать и примерно на 20 секунд окунуть в теплую воду. На обозначенном месте картинку отделить от бумаги и прижать промокательной бумагой.

Model W.O.T. 8

WWII British Truck

One of the largest supplier of trucks to the British forces was the Ford (UK) Motor Company in Dagenham .

W.O.T. 8 4x4 1,5 t version were built in 1941-1942 and were used in North Africa, Italy and NW Europe between 1942 and 1945, remaining in service after WWII.

There were produced about 2500 W.O.T. 8 trucks.

Technical Specifications of W.O.T. 8 truck

Full load, t.....	1.5
Length, mm.....	5220
Width, mm.....	2320
Height, mm.....	2875
Wheel base, mm.....	3100
Engine.....	Ford V8, 3,62 l, 85 hp
Max. Speed, km/h.....	75

CAUTION!

Read the instructions thoroughly prior to assembly. Each component is numbered. Adhere to specified sequence of assembly. Tools required: knife and file for removal of components from frame; rubber bond, adhesive tape and clothes pegs for clamping components together after applying adhesive. Clean plastic components in a mild detergent solution and allow to air-dry so that paint and transfers adhere better. Prior to applying adhesive, check to see whether the components fit together; apply adhesive sparingly. Remove chrome and paint from the contact surfaces. Paint small components before removing them from the frame. Allow paint to dry well, and only then continue to assemble. Cut out each transfer individually and immerse in warm water for approx. 20 seconds. Slide transfer off paper and into designated position, then press on with blotting paper.

ИСПОЛЬЗУЕМЫЕ КРАСКИ / USED COLORS:

	Revell	Tamiya		
A	105	XF2	Белый, матовый	Flat White
B	107	X1	Черный, глянцевоый	Gloss Black
C	302	X18	Черный, полуматовый	Semigloss Black
D	165	XF58	Оливково-зеленый, мат.	Olive Green
E	186	XF49	Хаки, матовый	Khaki

	Revell	Tamiya		
F	189	XF78	Дерево	Wood
G	191	X32	Сталь	Steel
H	190	X11	Серебристый	Chrome Silver
J	731	X27	Красный, прозрачный	Clear Red
K	183	XF84	Ржавчина	Rust

01 СТАДИЯ СБОРКИ
ASSEMBLY STEP

A ИСПОЛЬЗУЕМАЯ КРАСКА
USED COLOR

✂ ОТРЕЗАТЬ
CUT OFF

? ПРОИЗВОЛЬНЫЙ ВЫБОР
OPTIONAL

03 СБОРОЧНАЯ ЕДИНИЦА
ASSEMBLY UNIT

■ ПРИ СБОРКЕ НЕ ИСПОЛЬЗУЕТСЯ
PARTS NOT FOR USE

↩ СОГНУТЬ
BEND

x2 СДЕЛАТЬ ДВЕ ДЕТАЛИ
MAKE 2 PCS

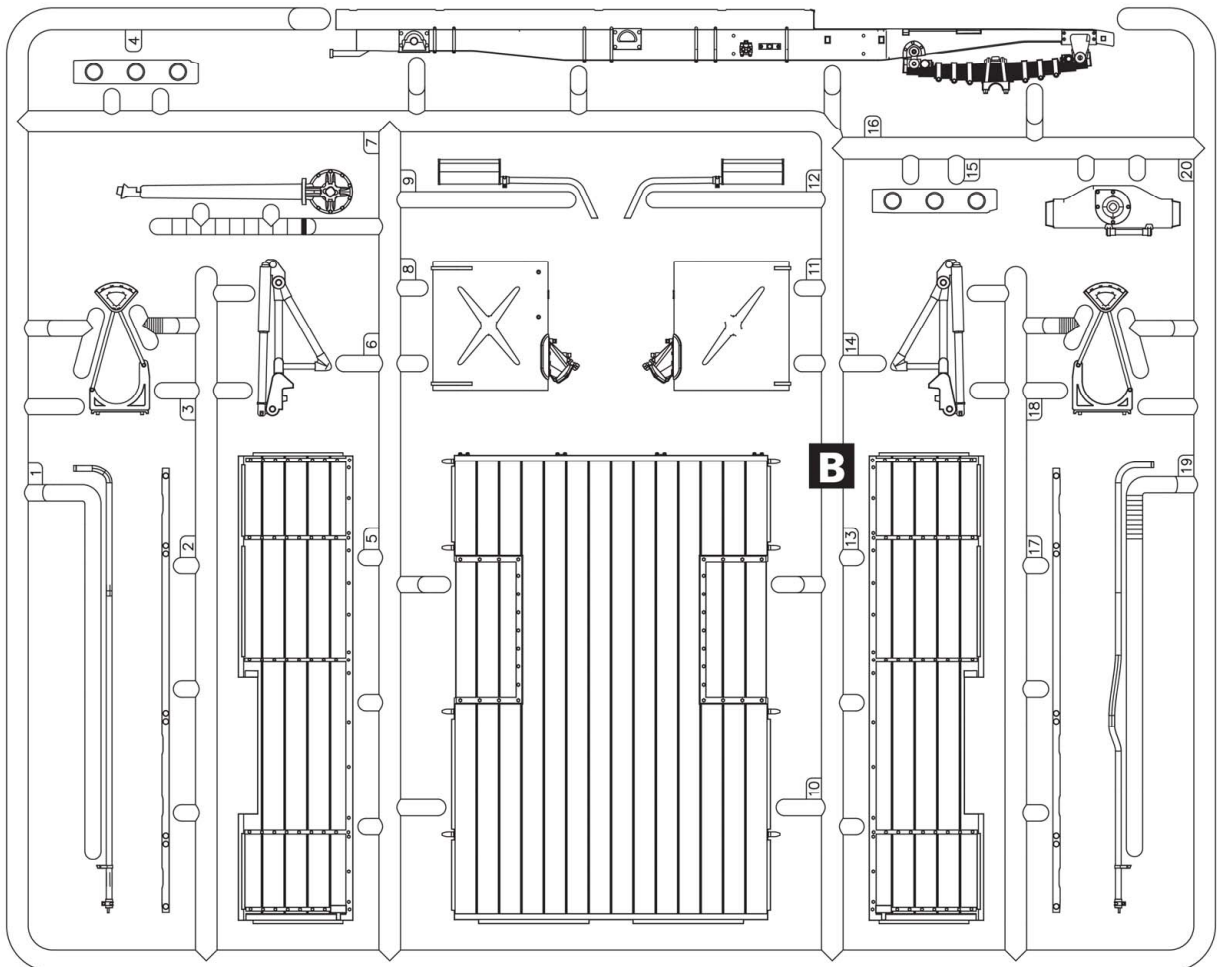
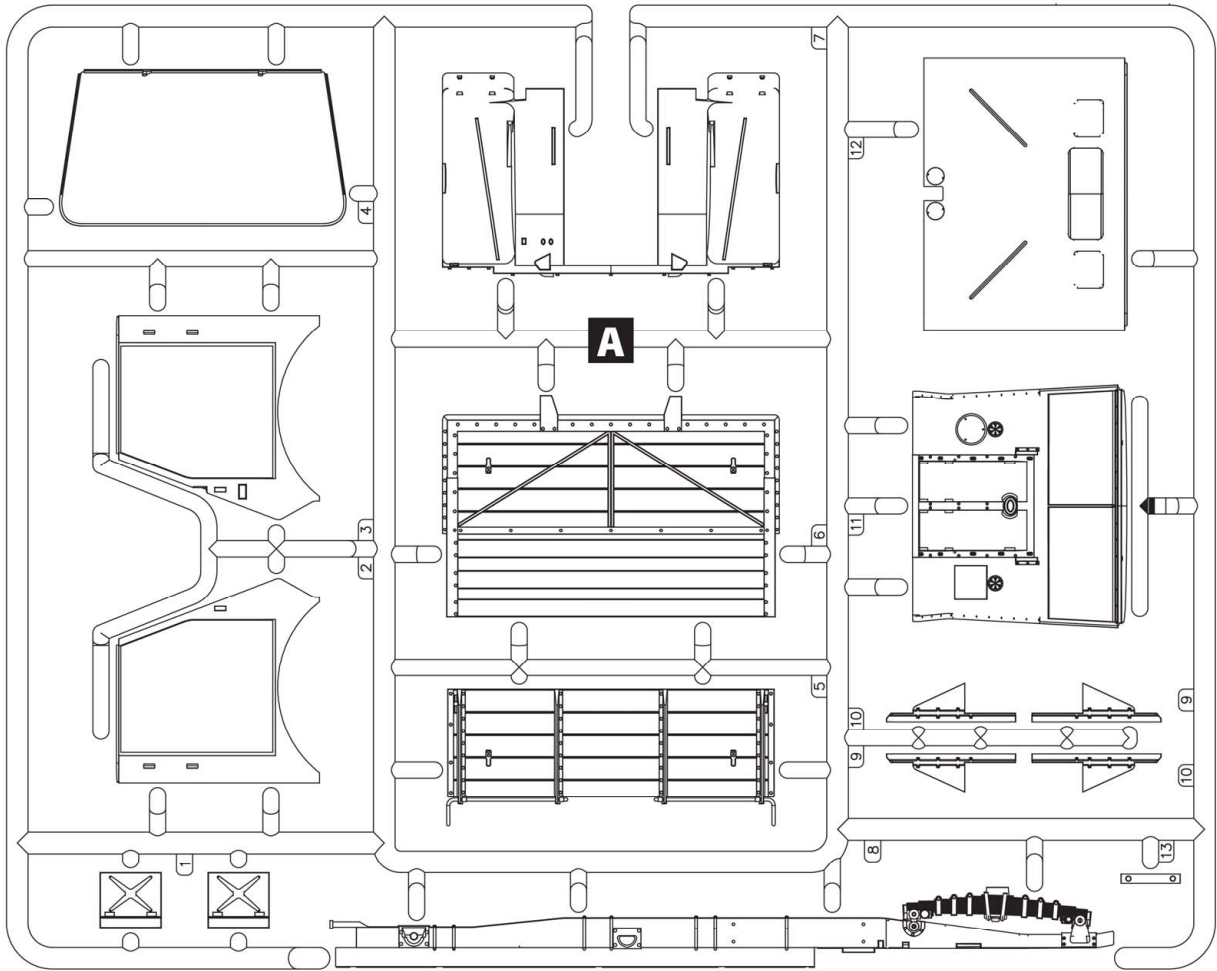

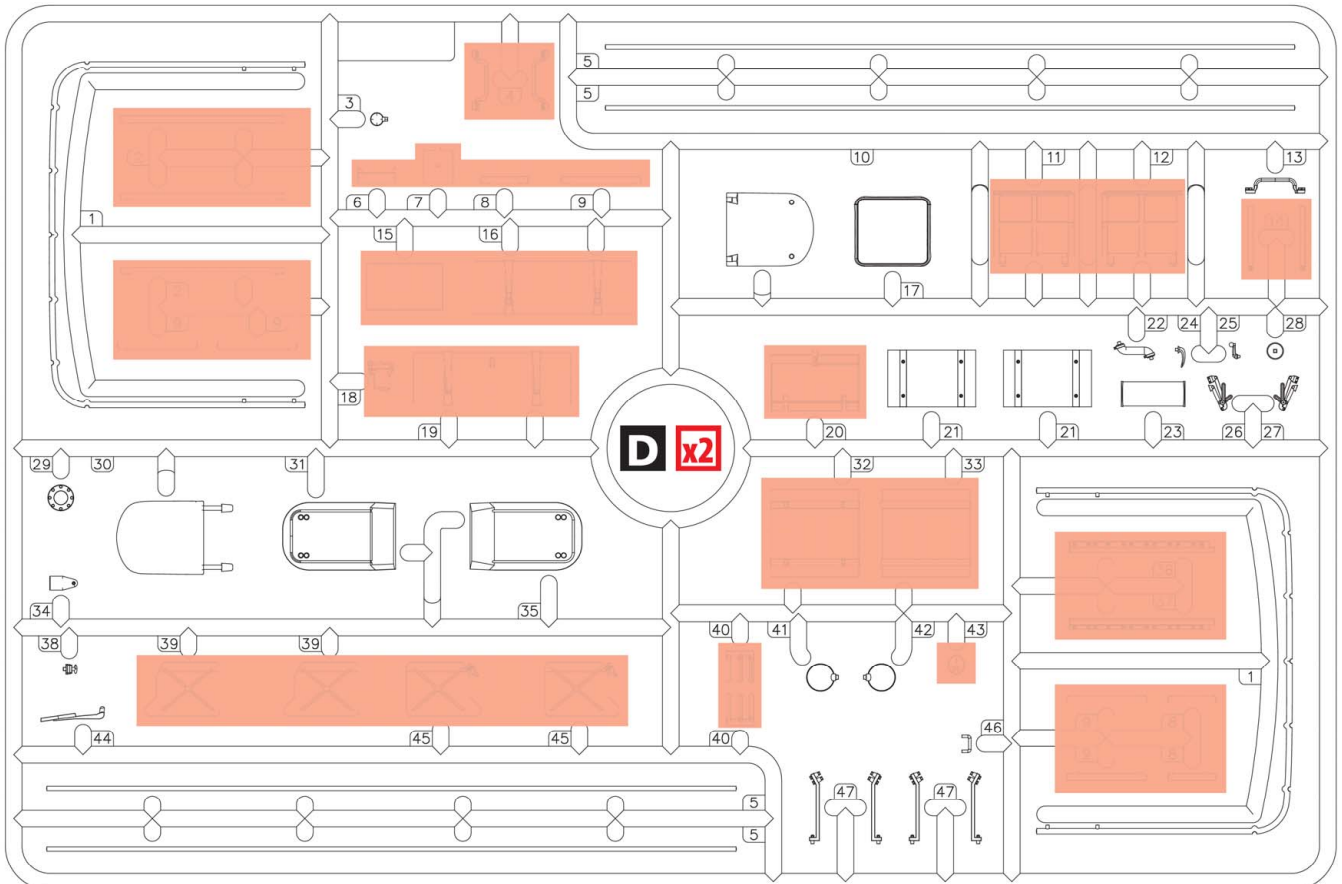
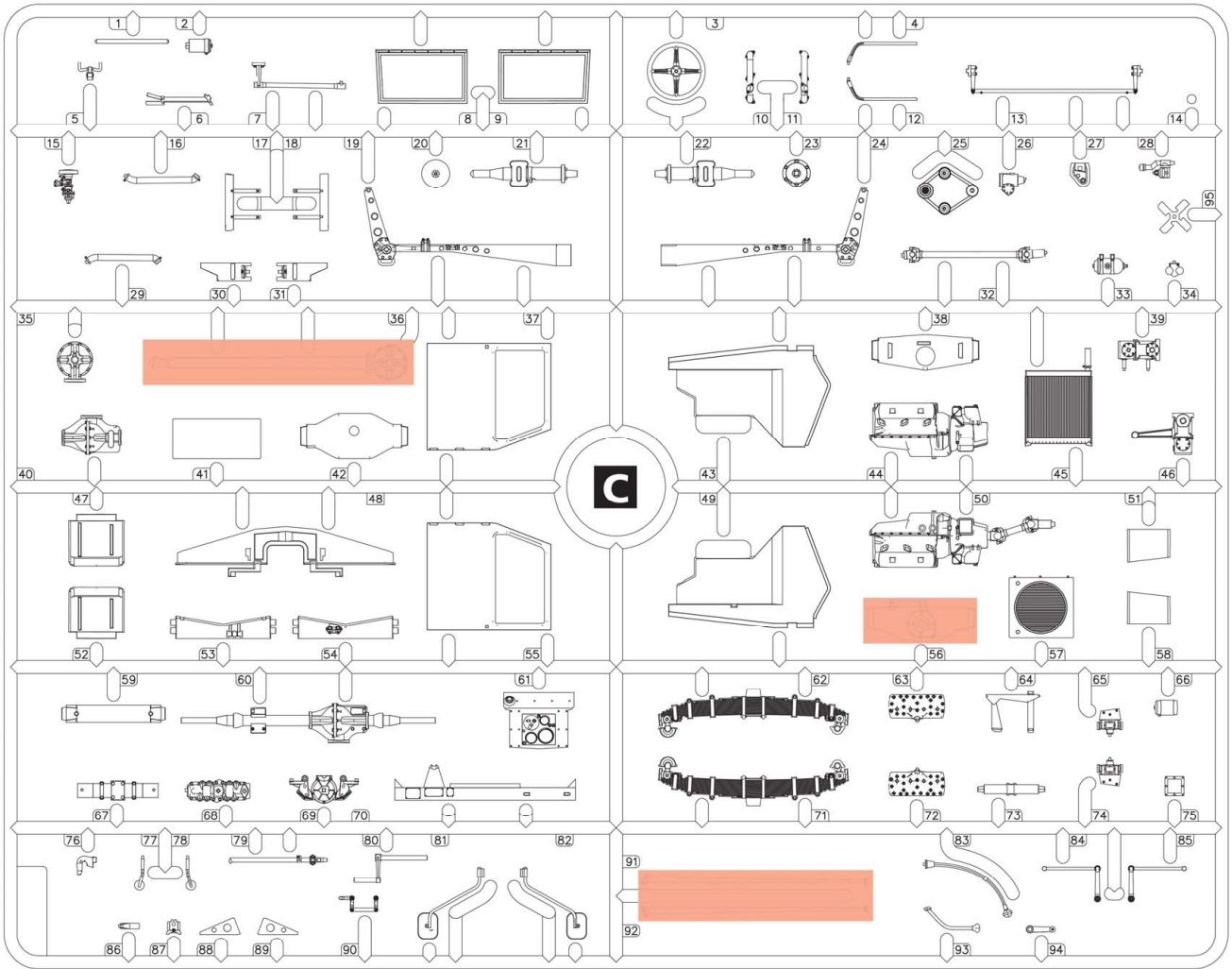

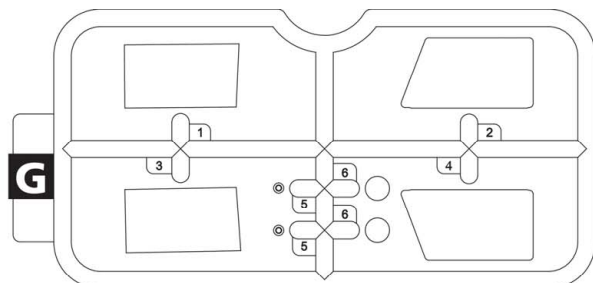
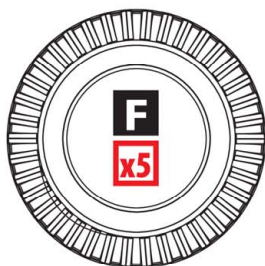
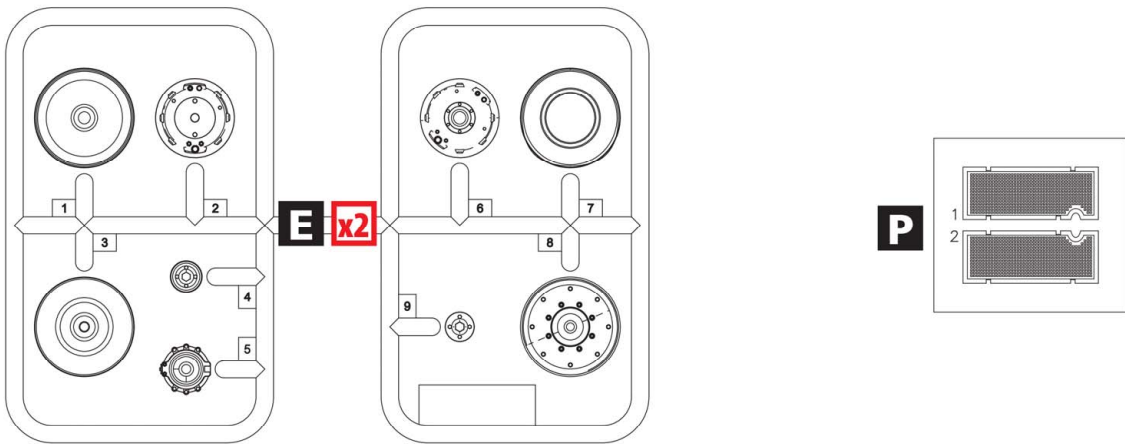
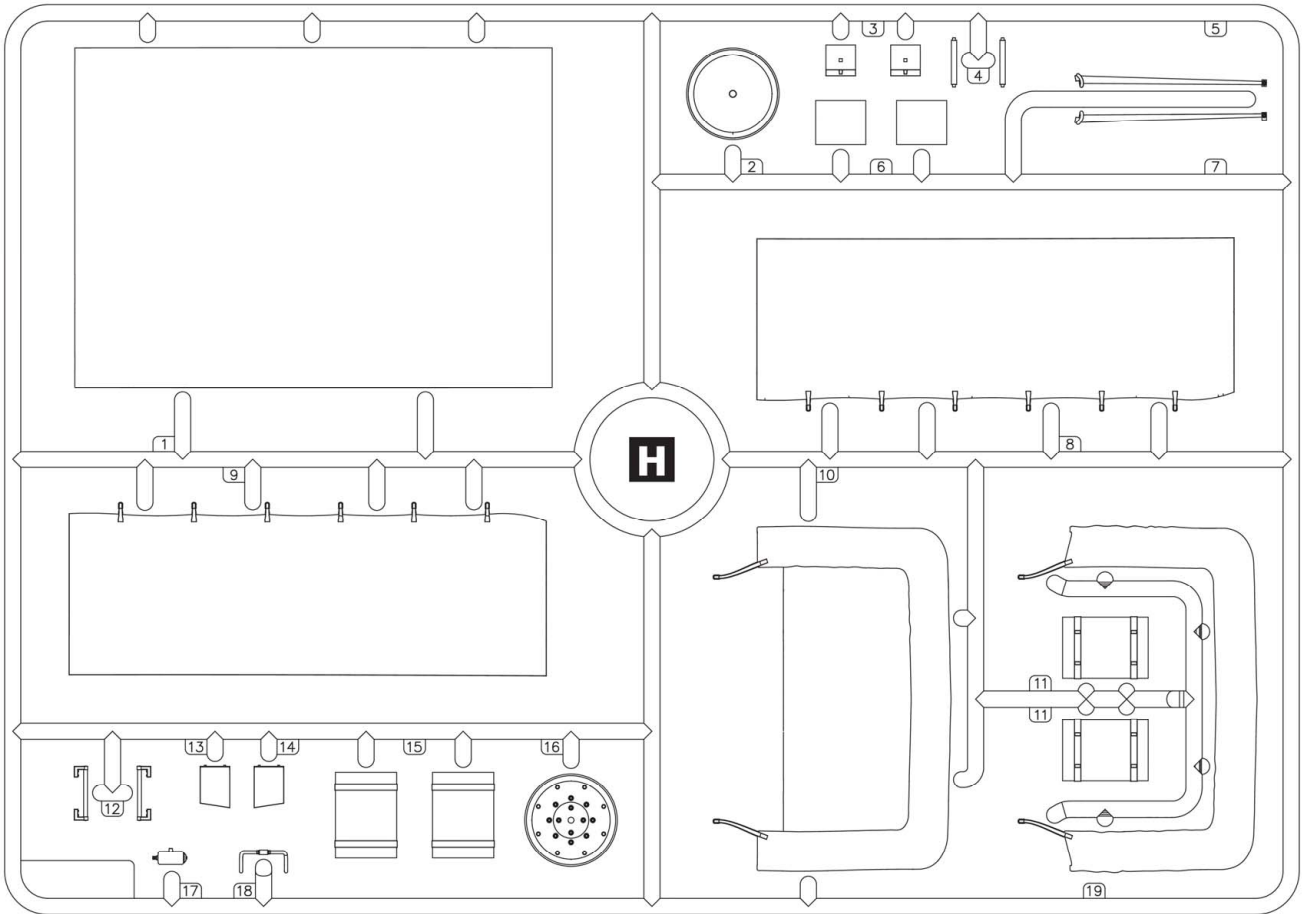

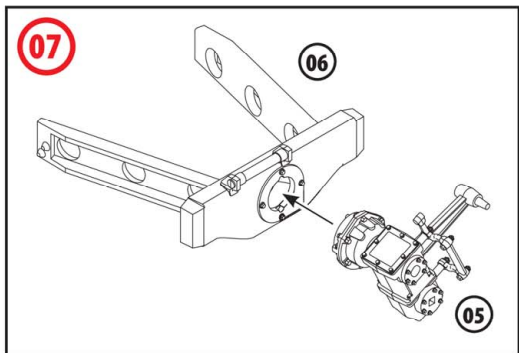
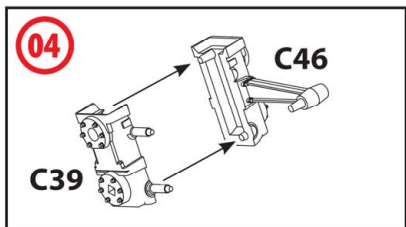
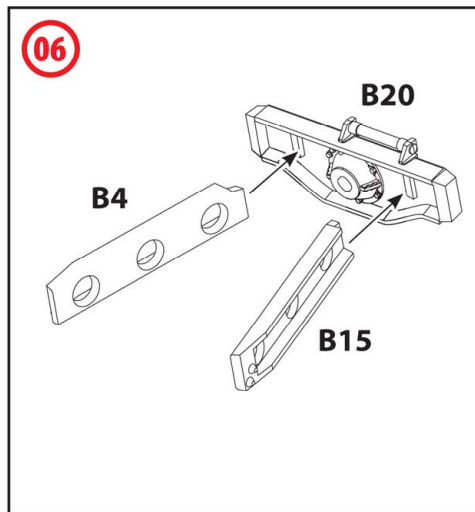
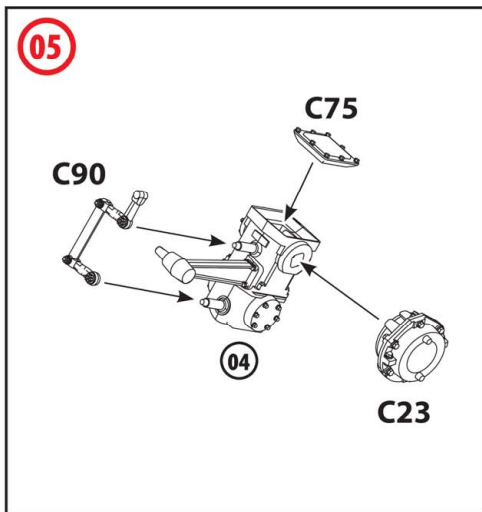
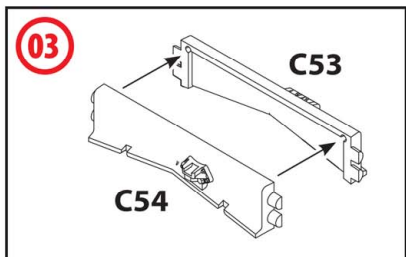
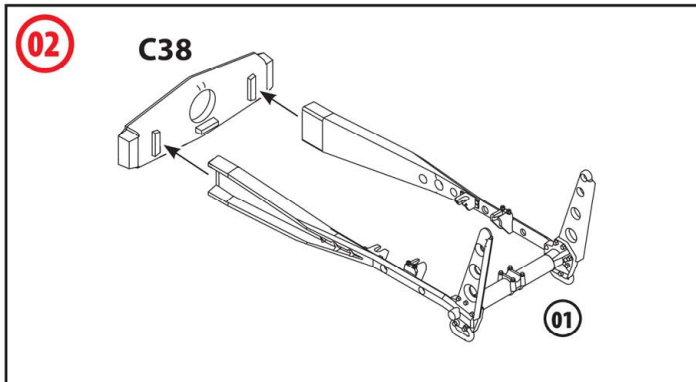
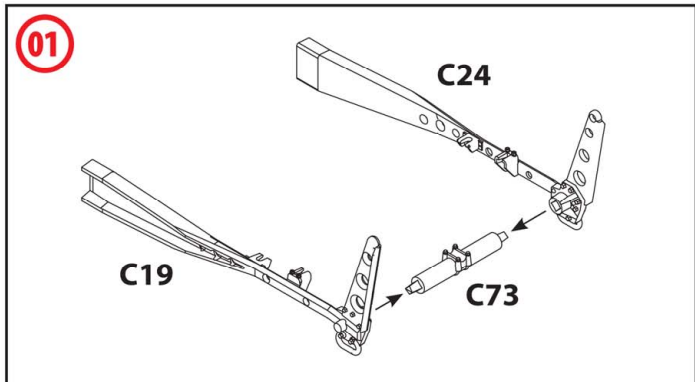

D ВСЕ ДЕТАЛИ ШАССИ, КРОМЕ ОБОЗНАЧЕННЫХ ОТДЕЛЬНО
 ALL CHASSIS DETAILS EXCEPT MARKED SEPARATLY

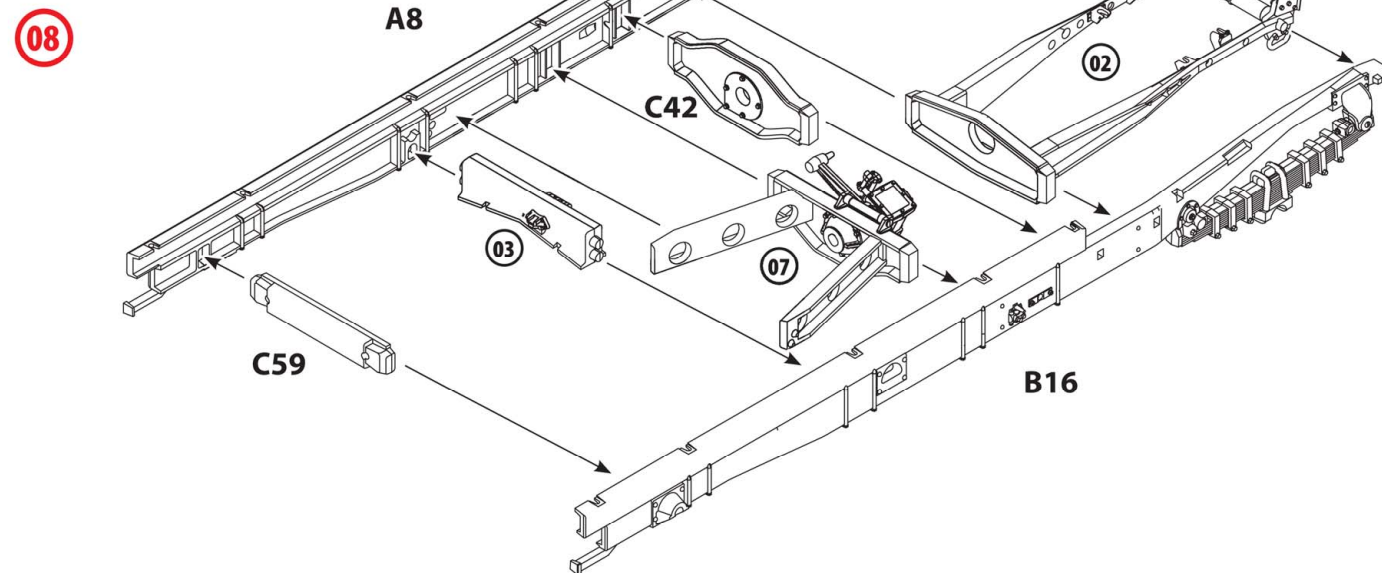

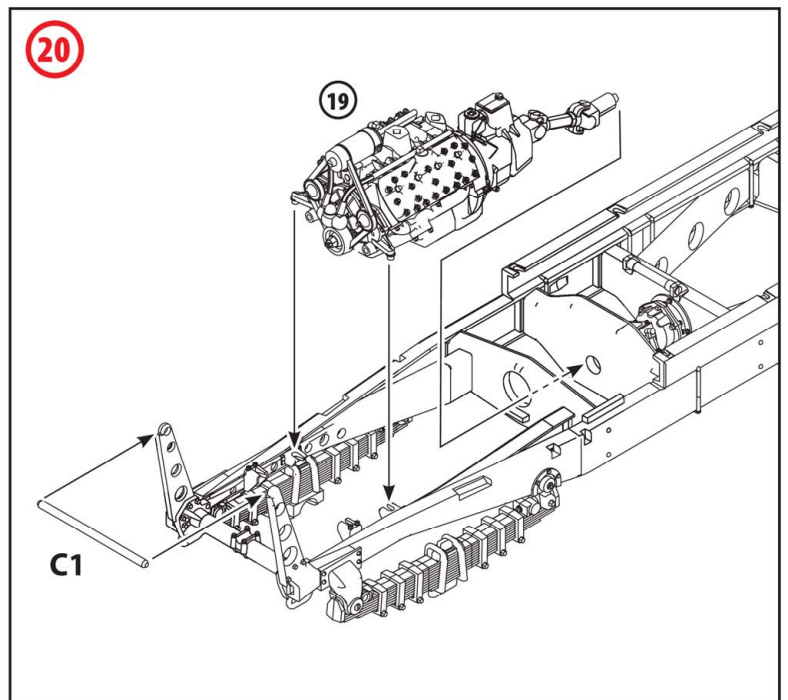
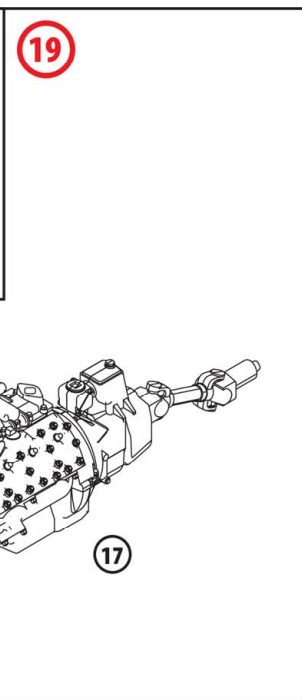
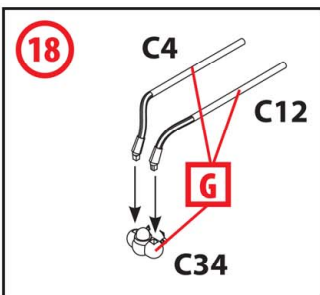
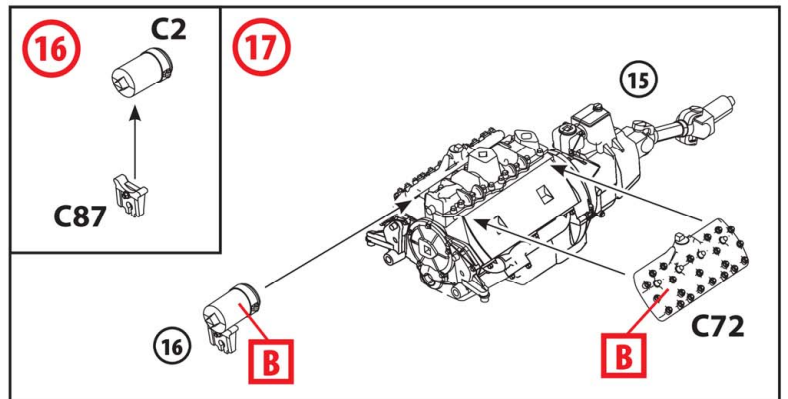
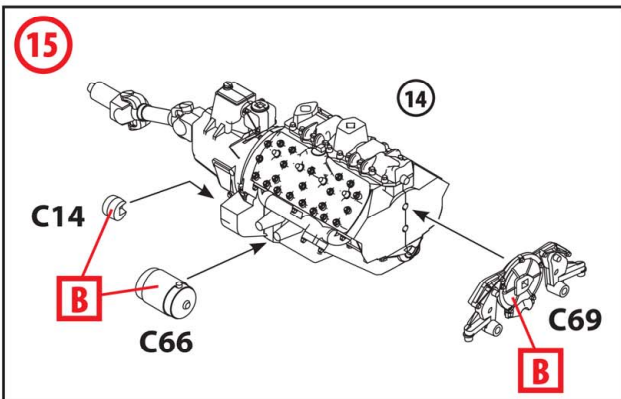
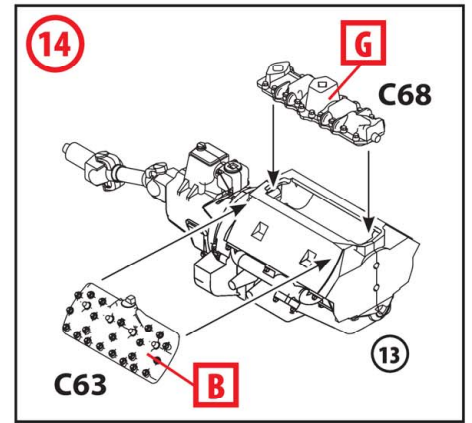
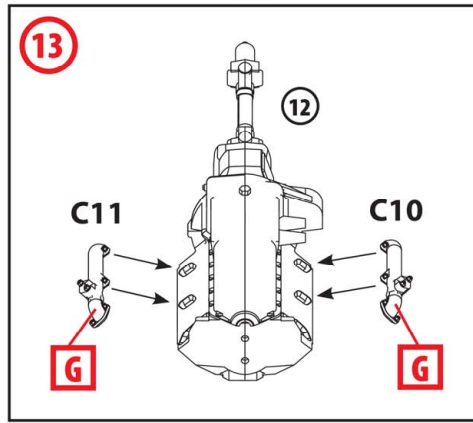
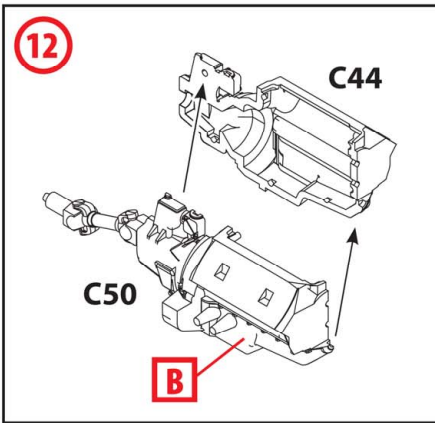
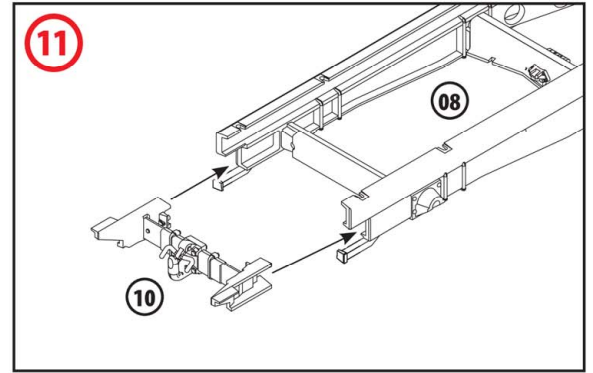
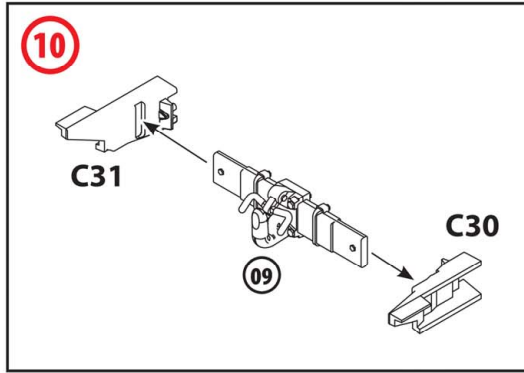
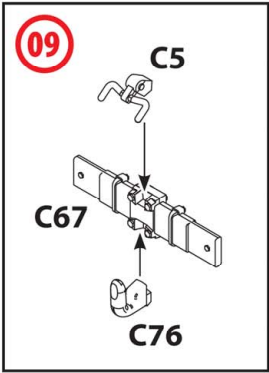

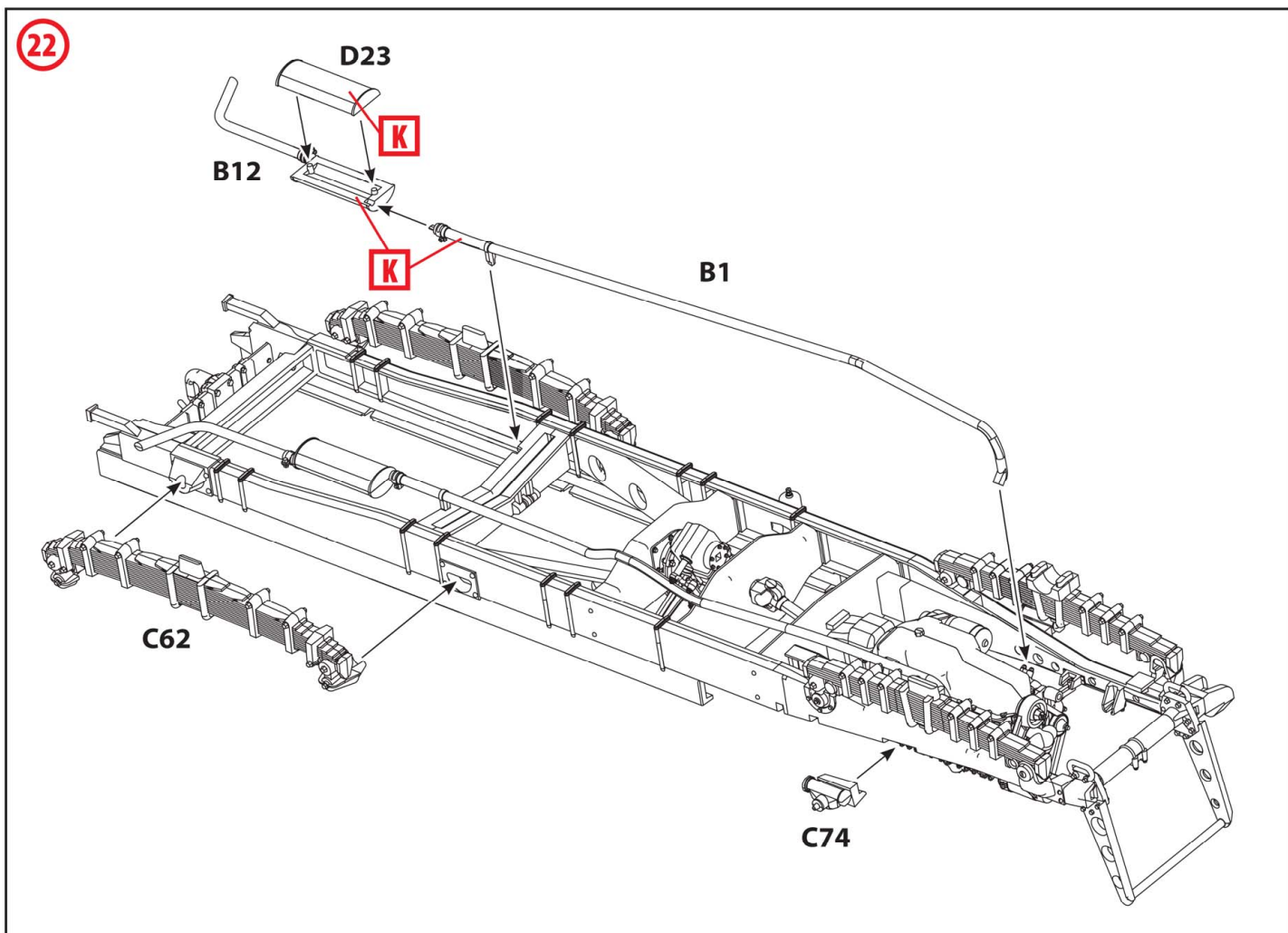
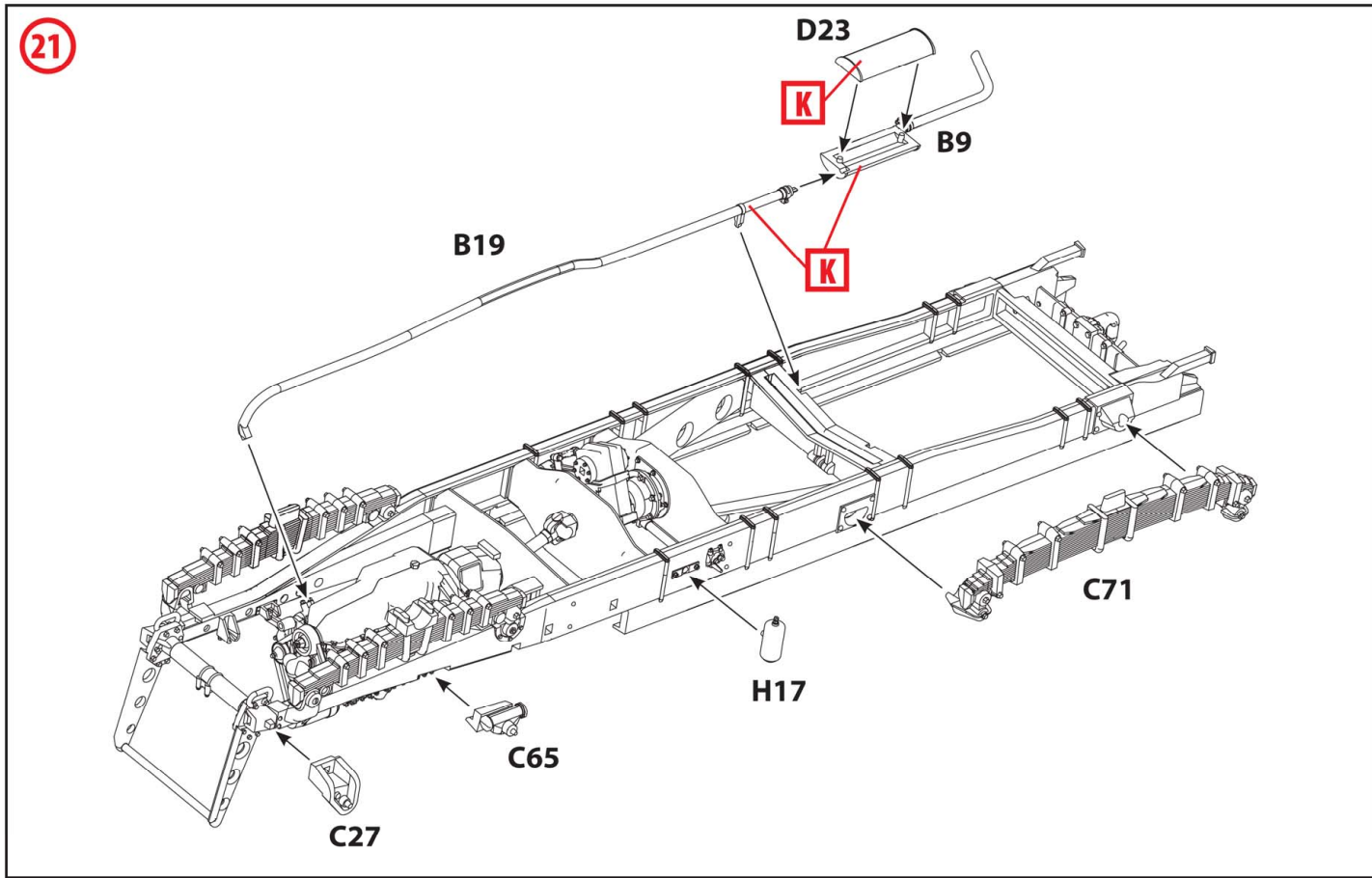

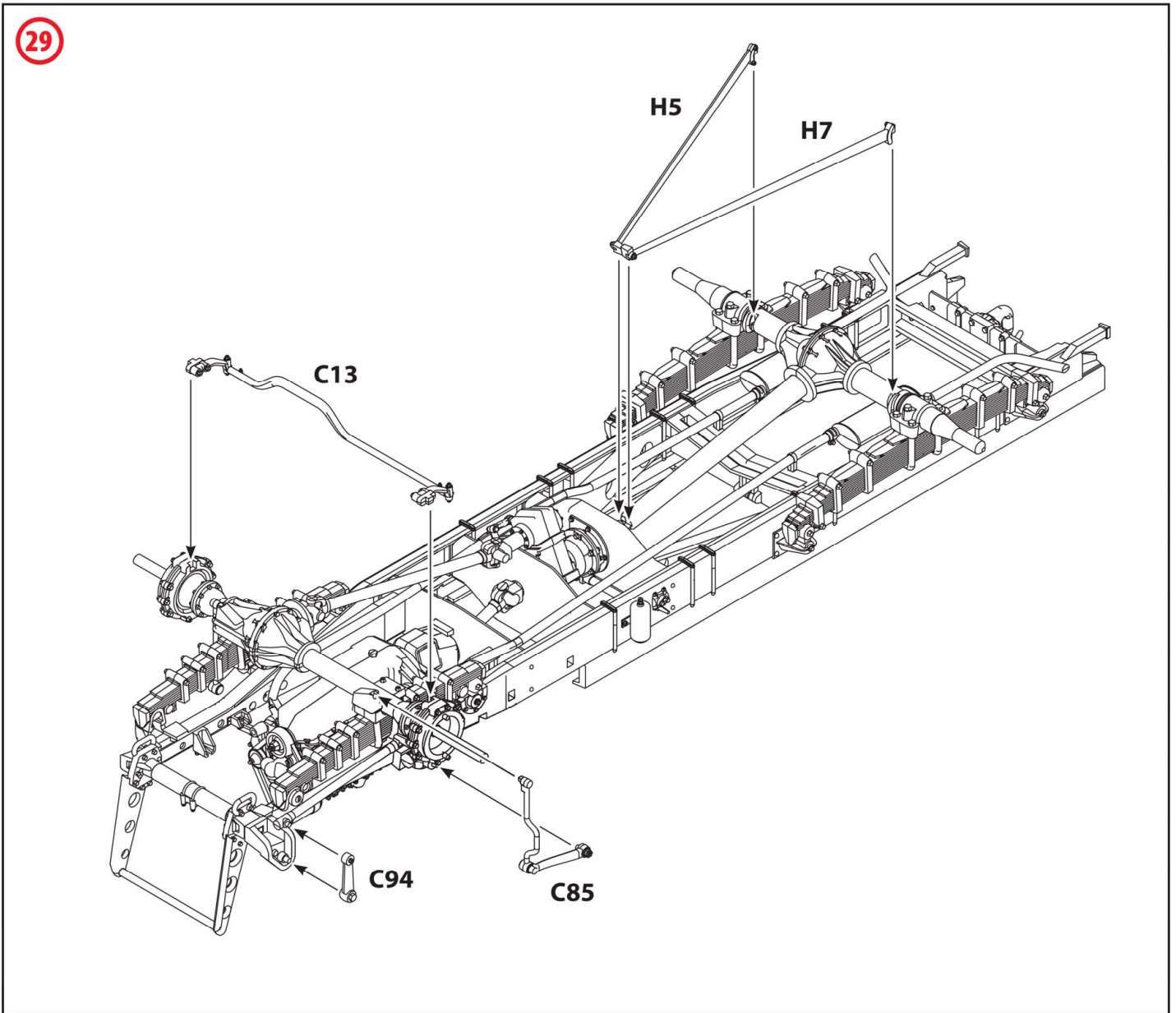
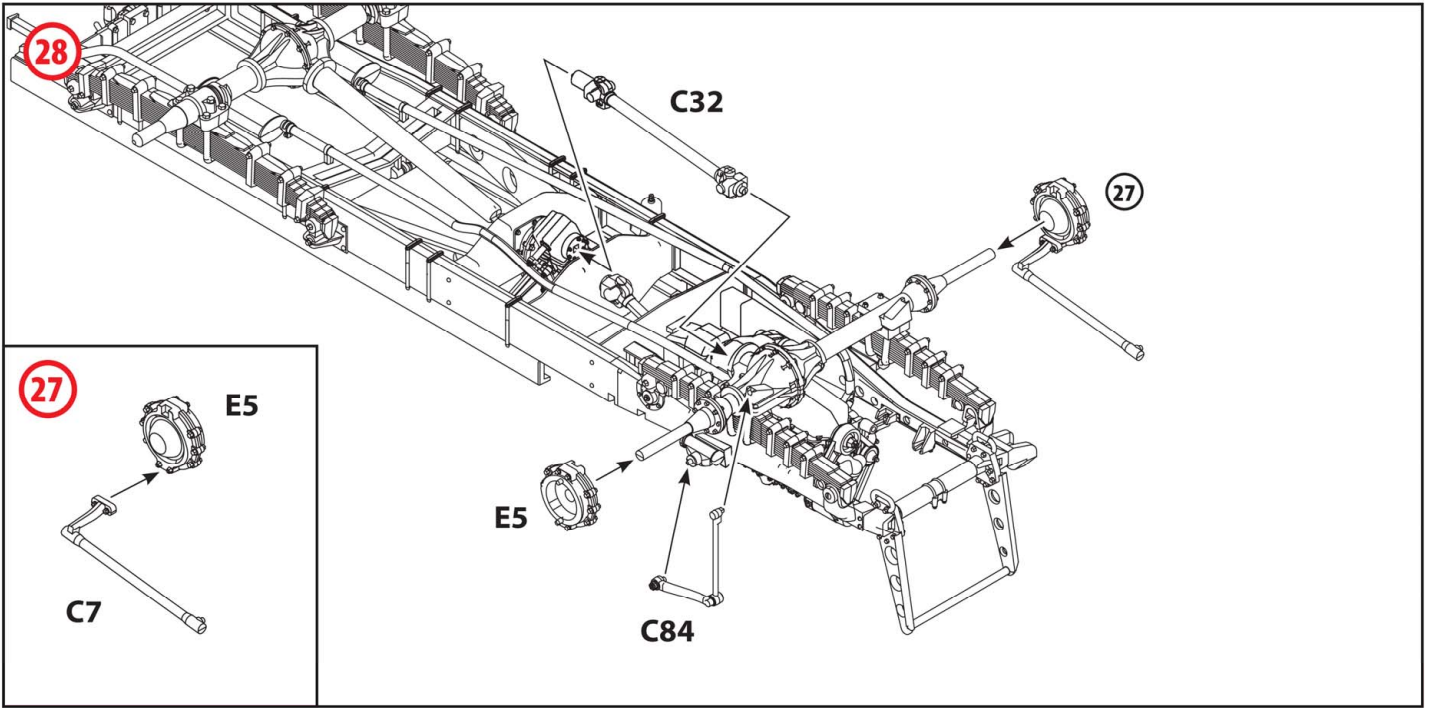

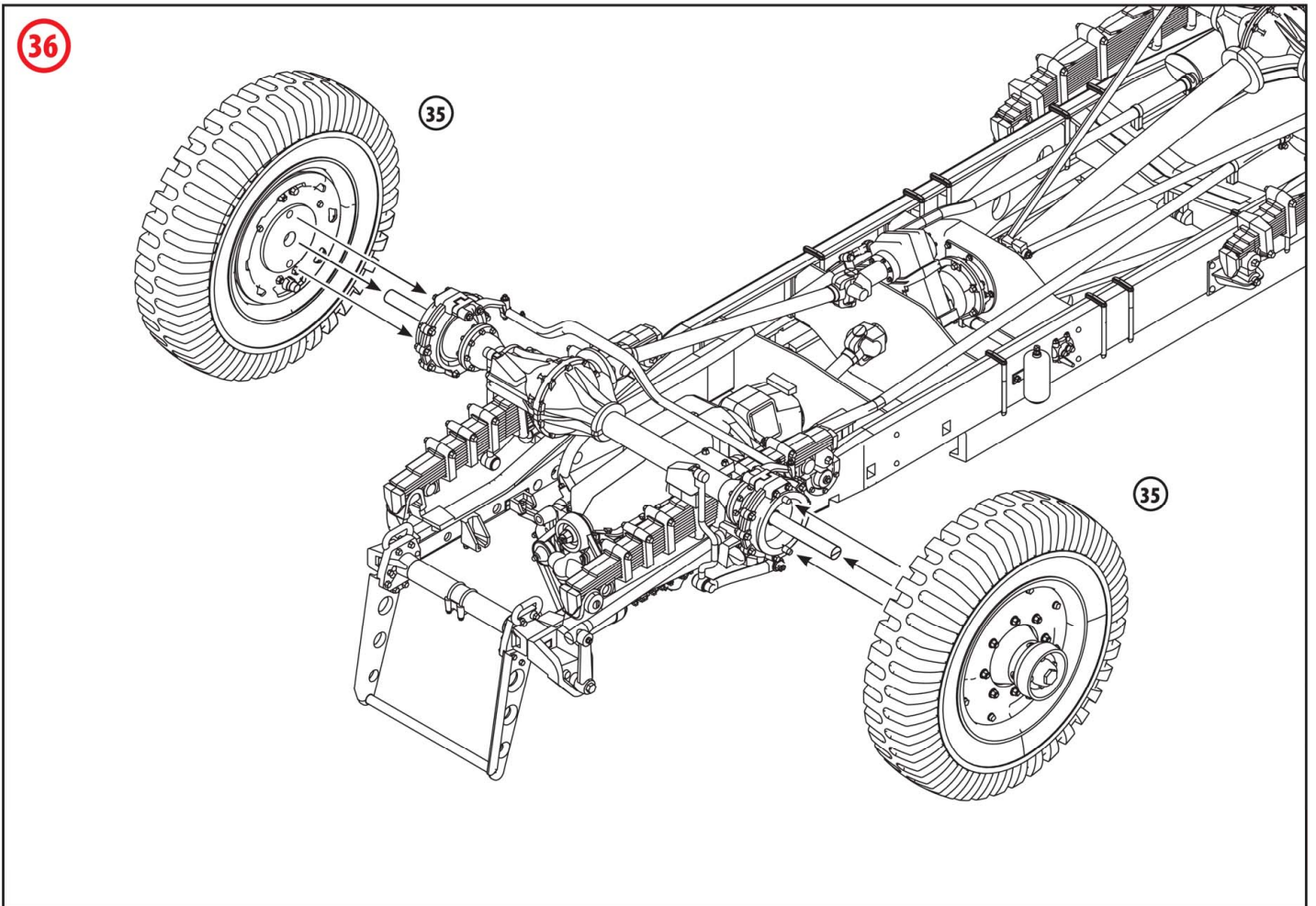
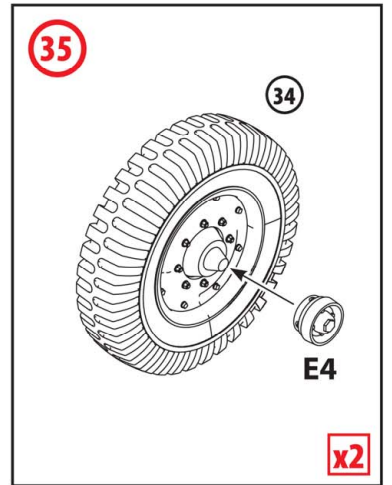
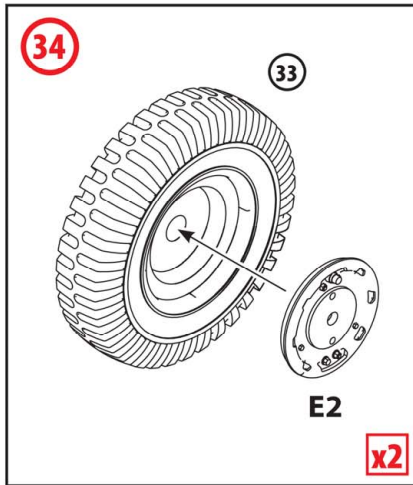
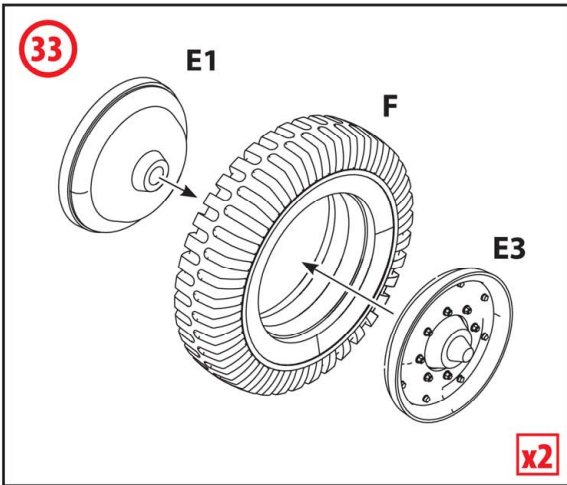
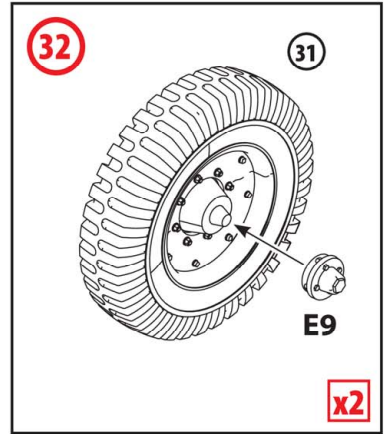
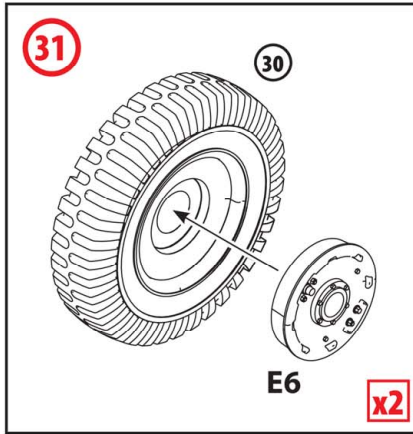
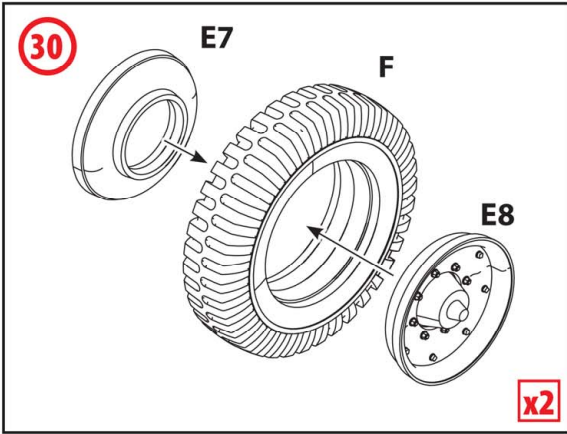

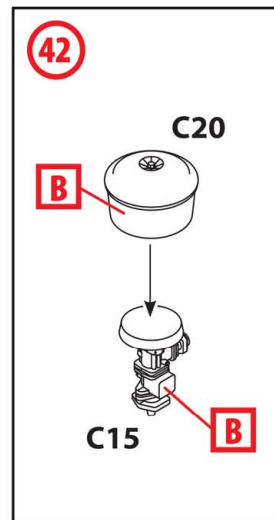
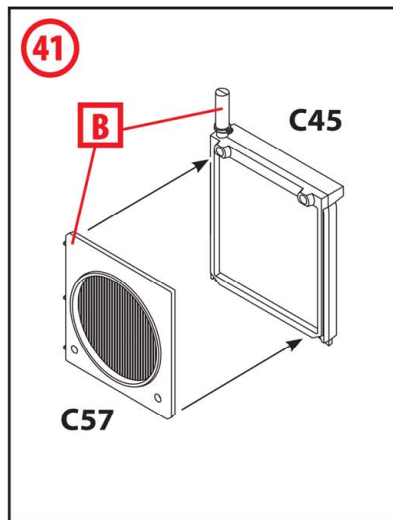
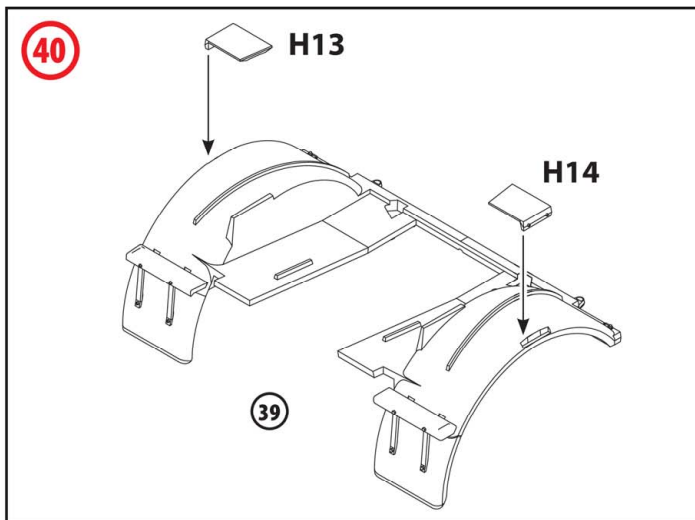
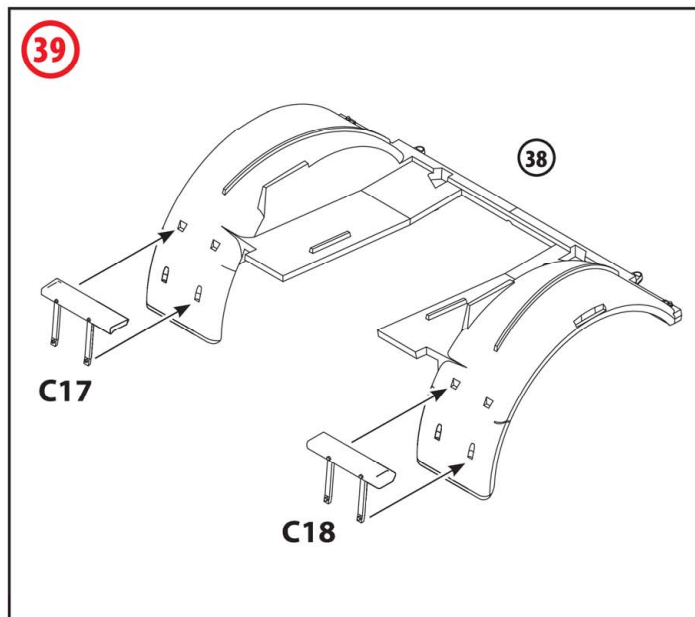
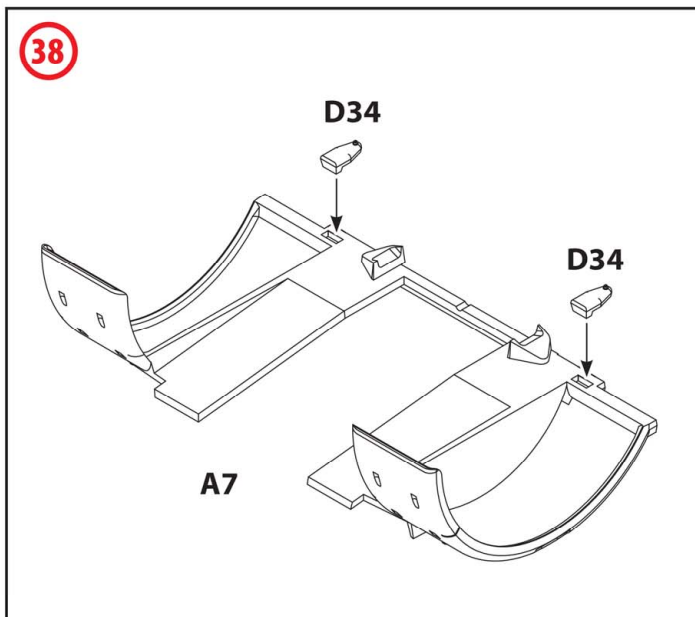
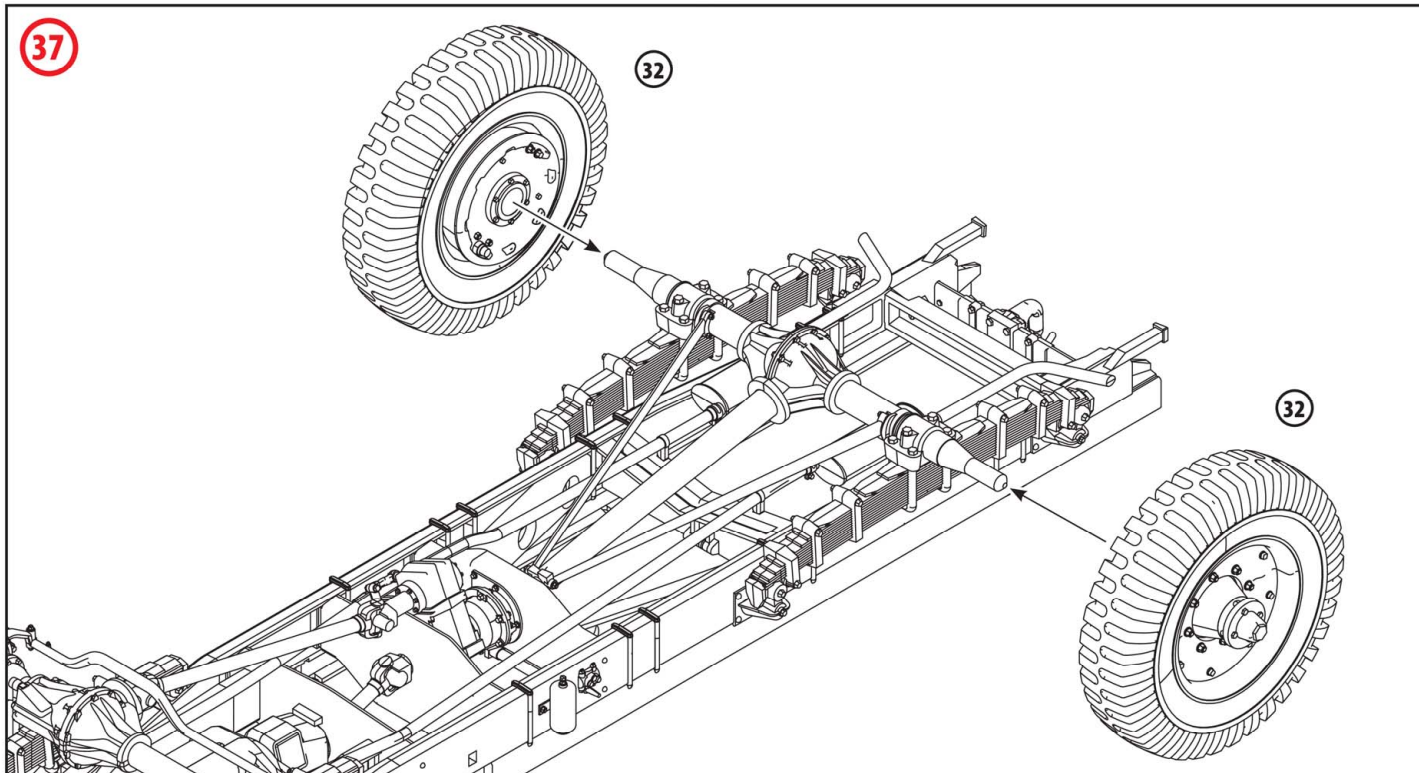

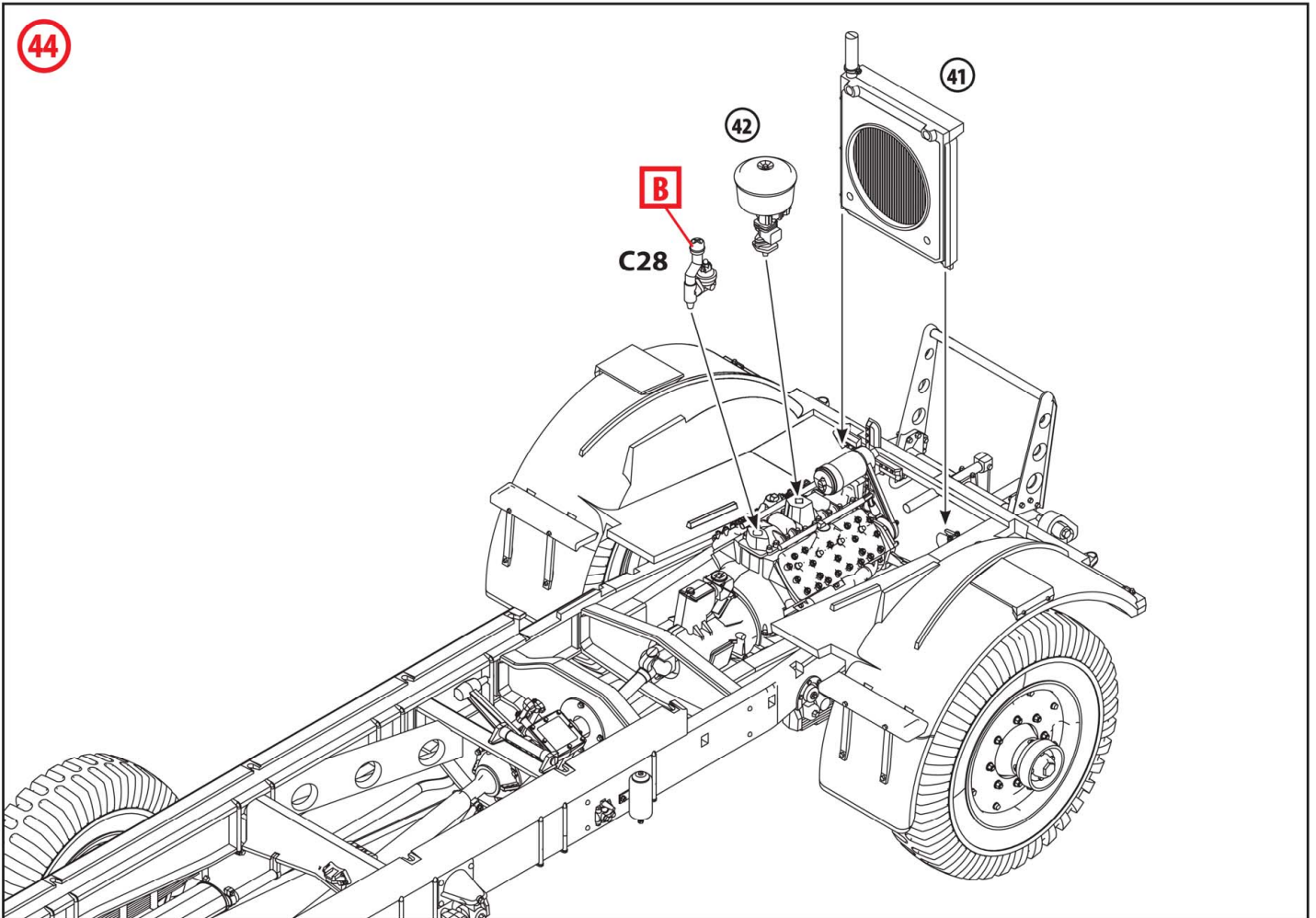
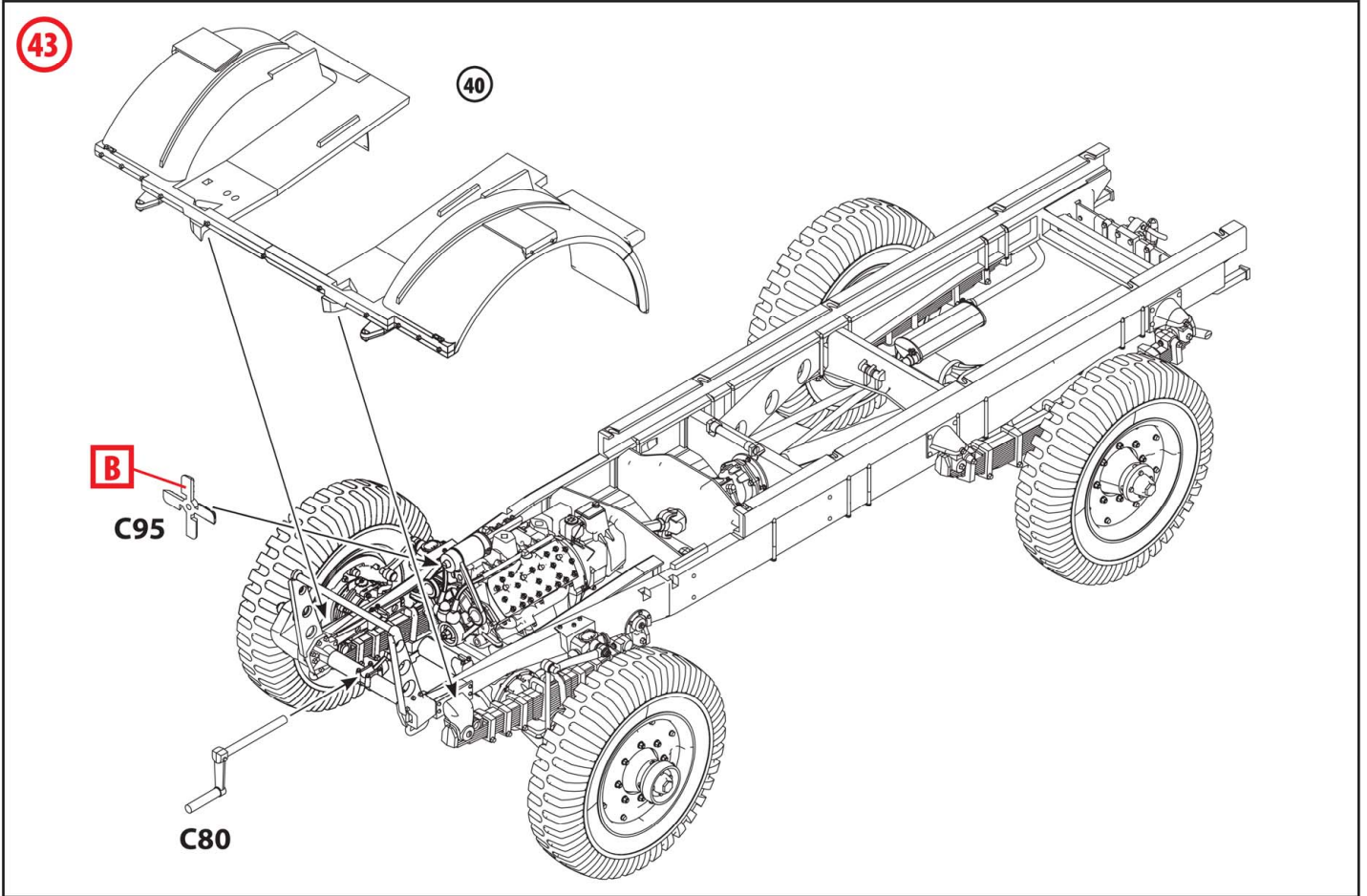

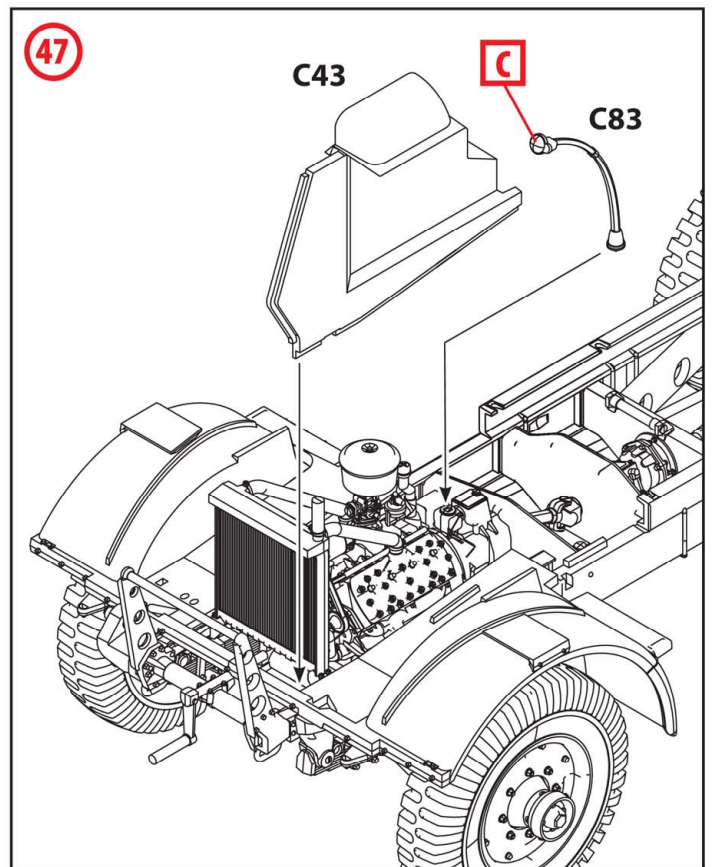
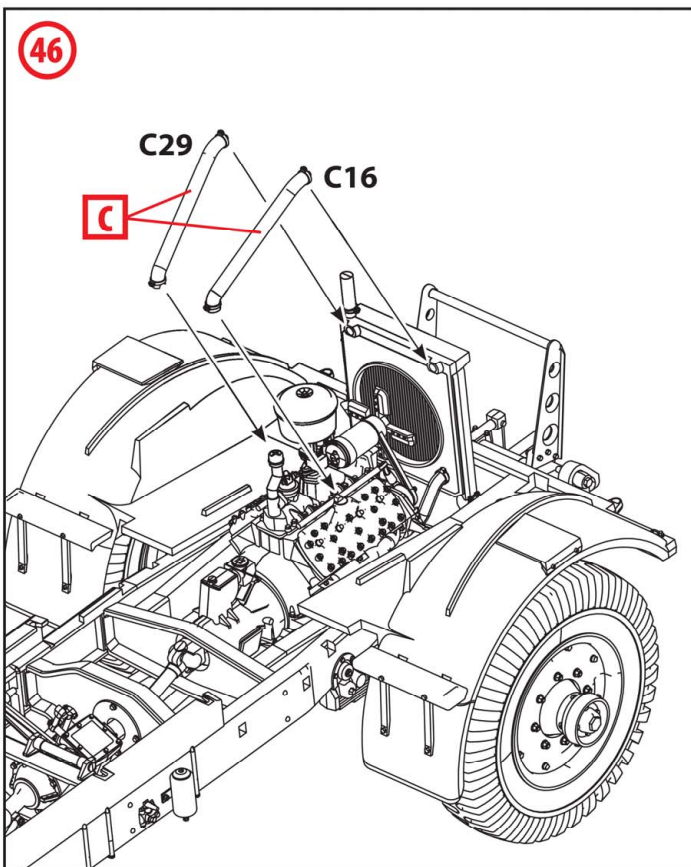
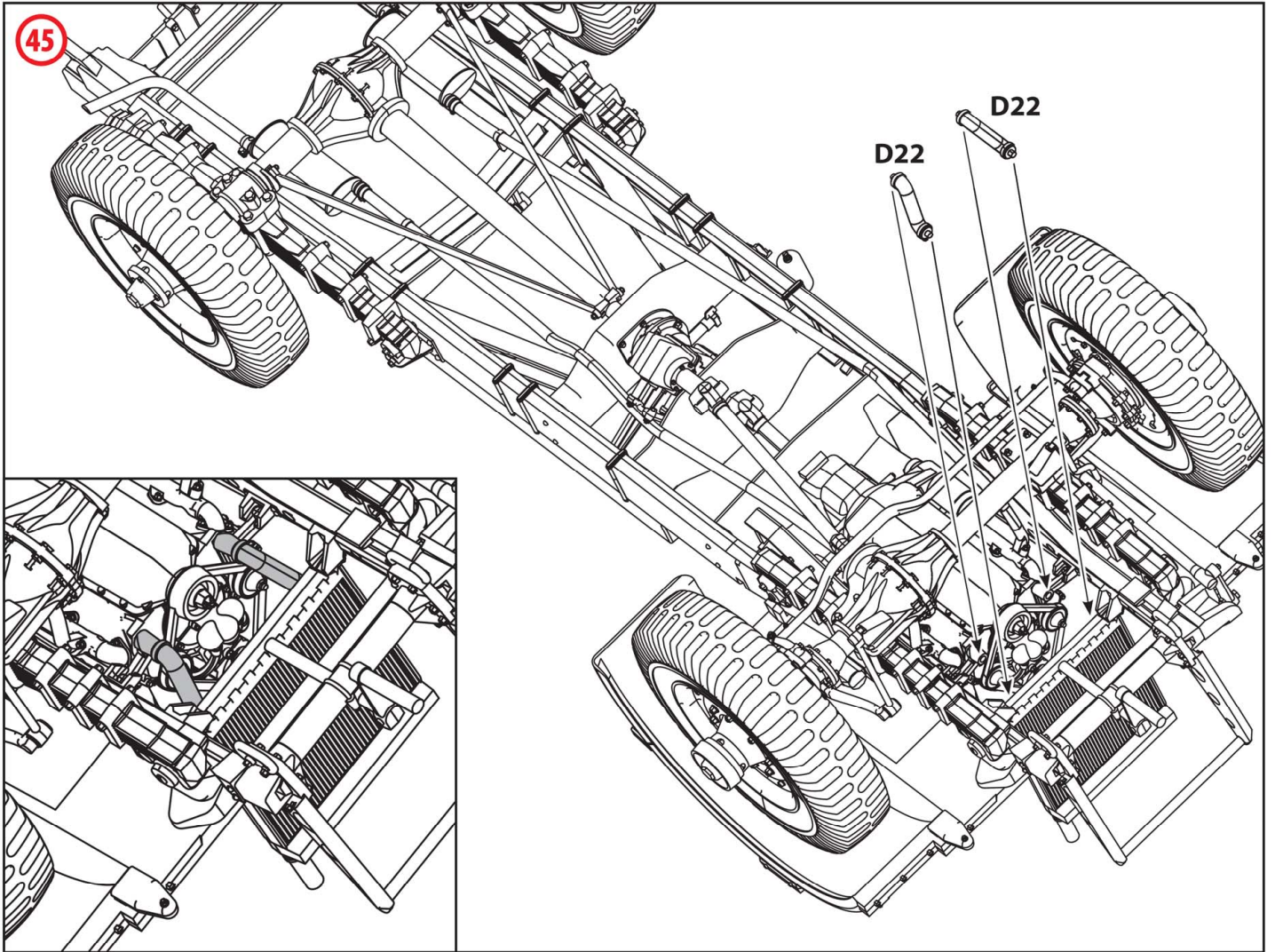

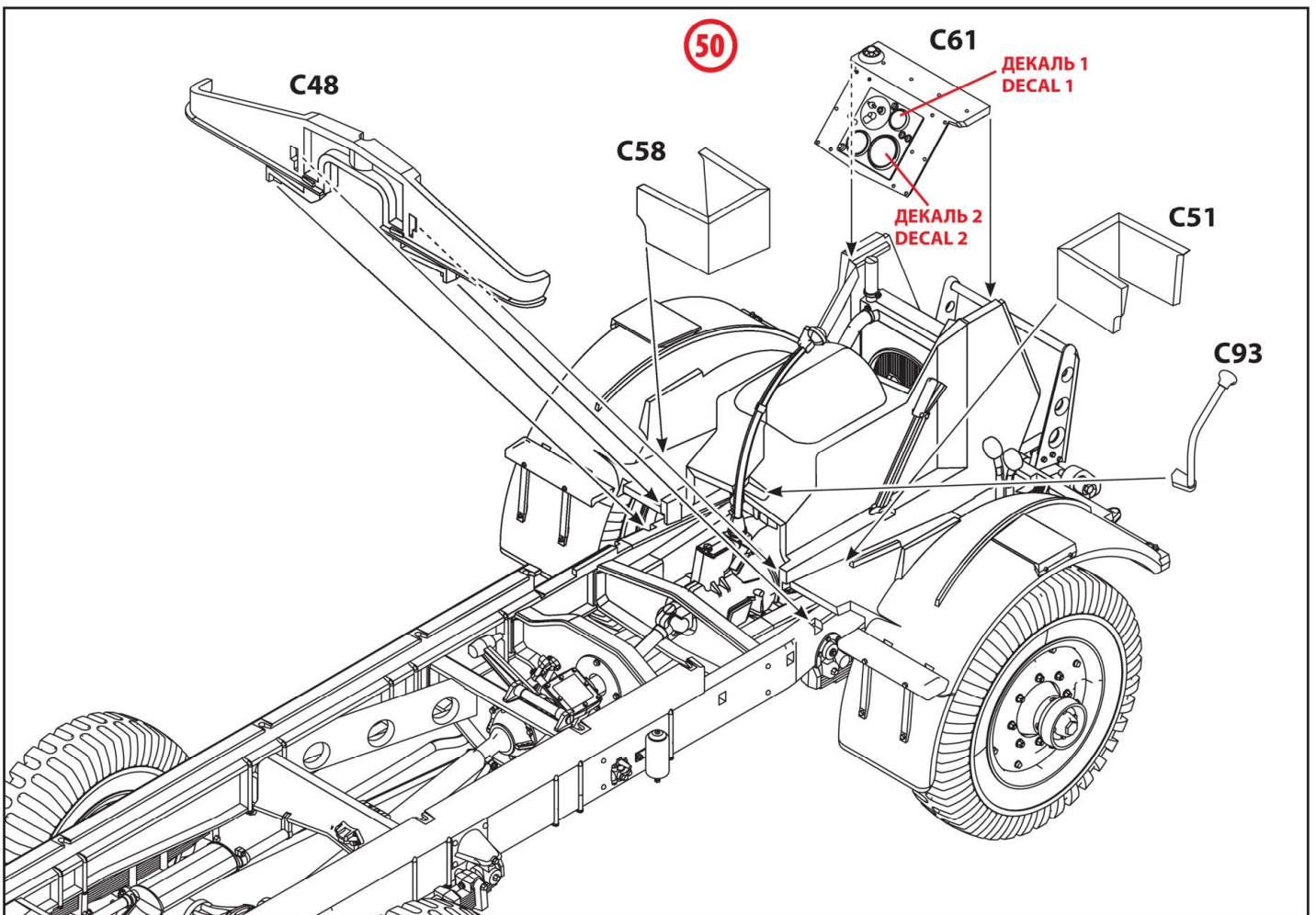
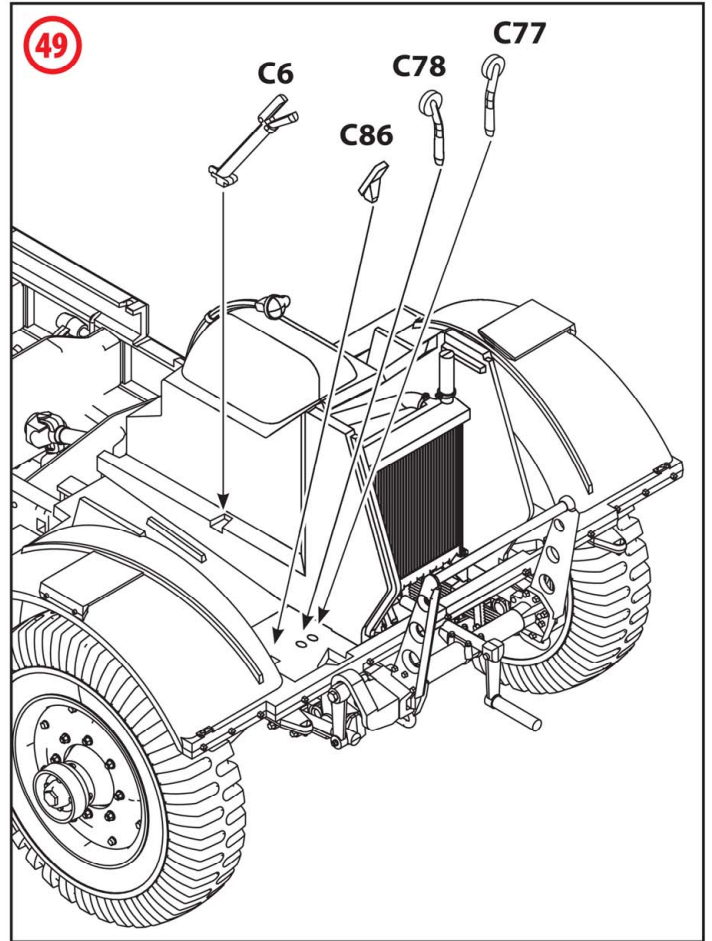
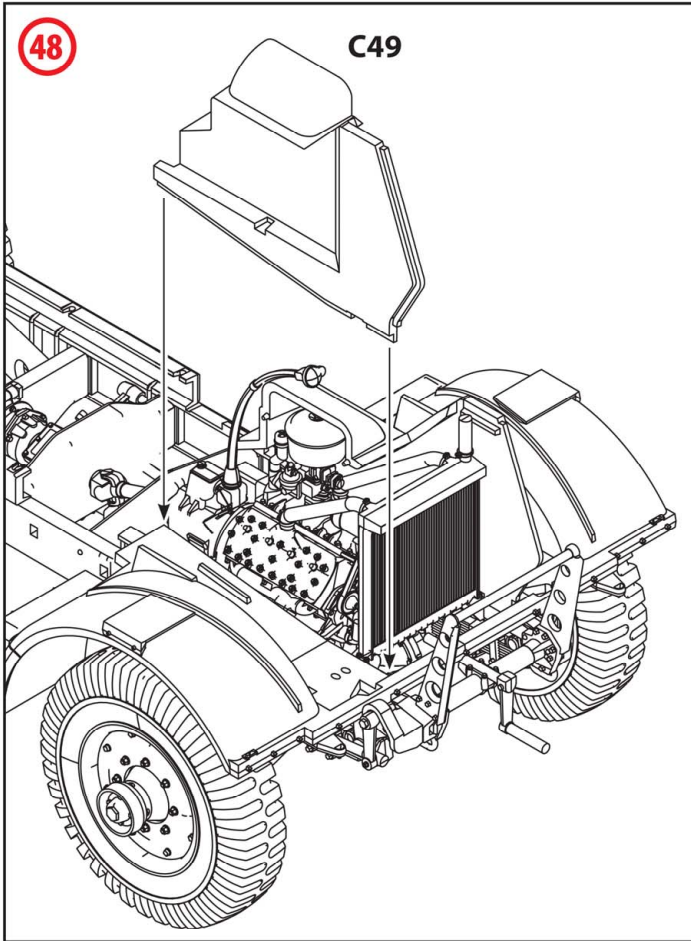

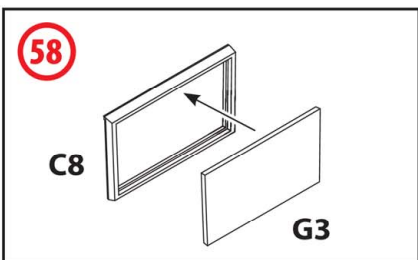
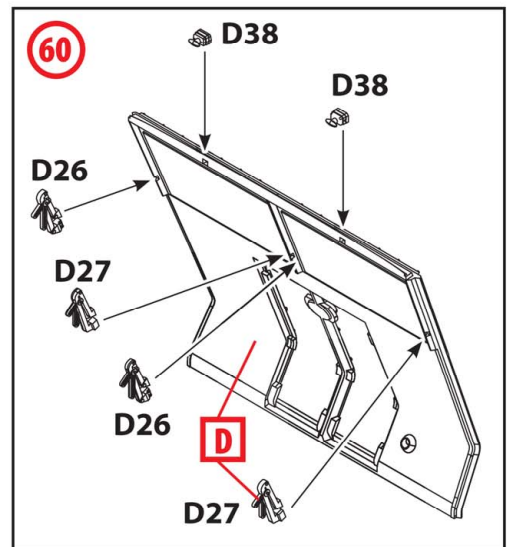
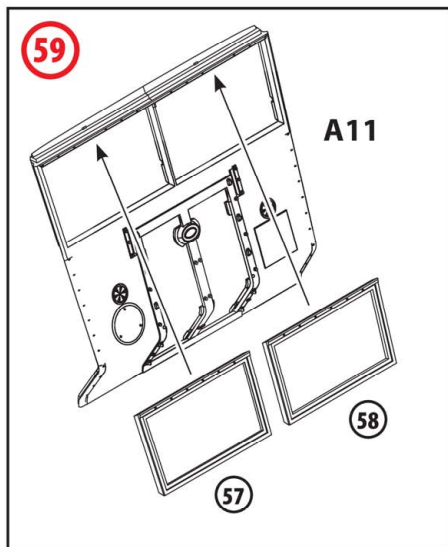
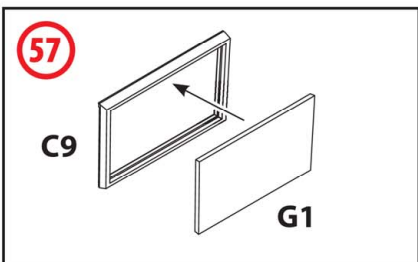
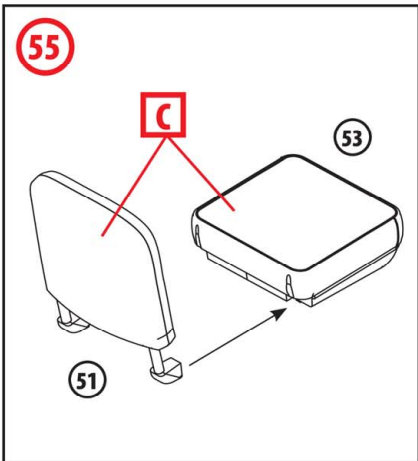
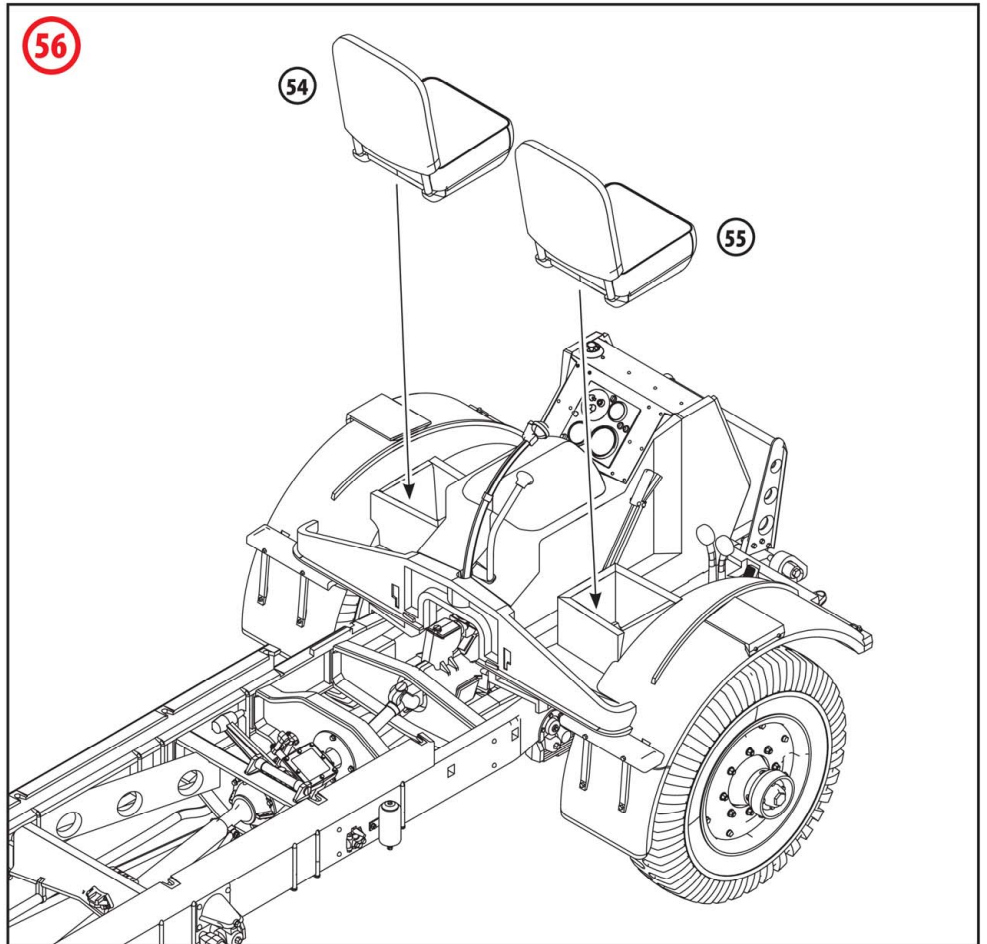
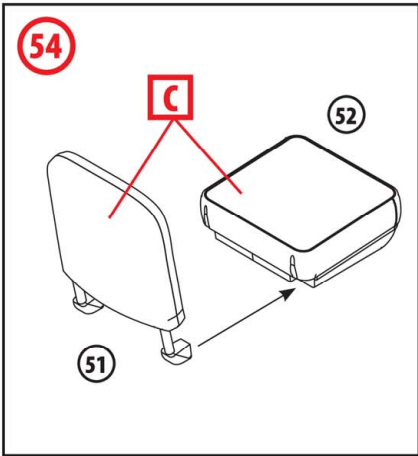
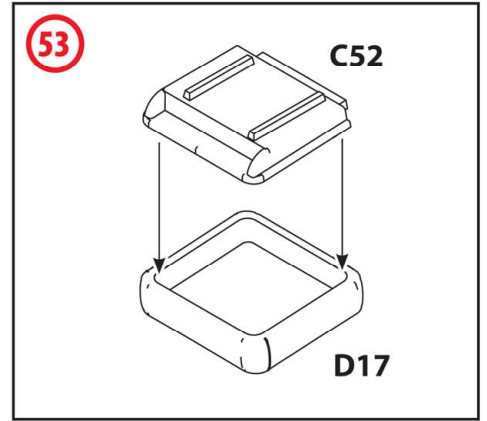
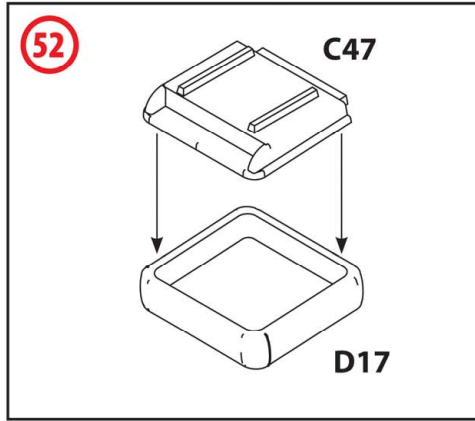
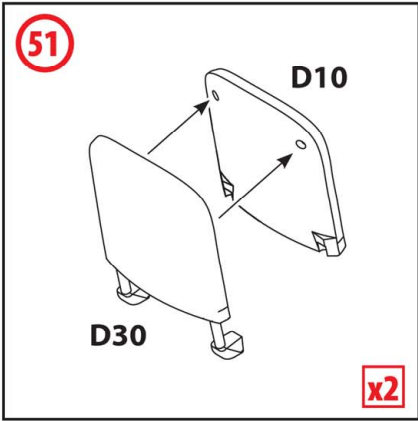

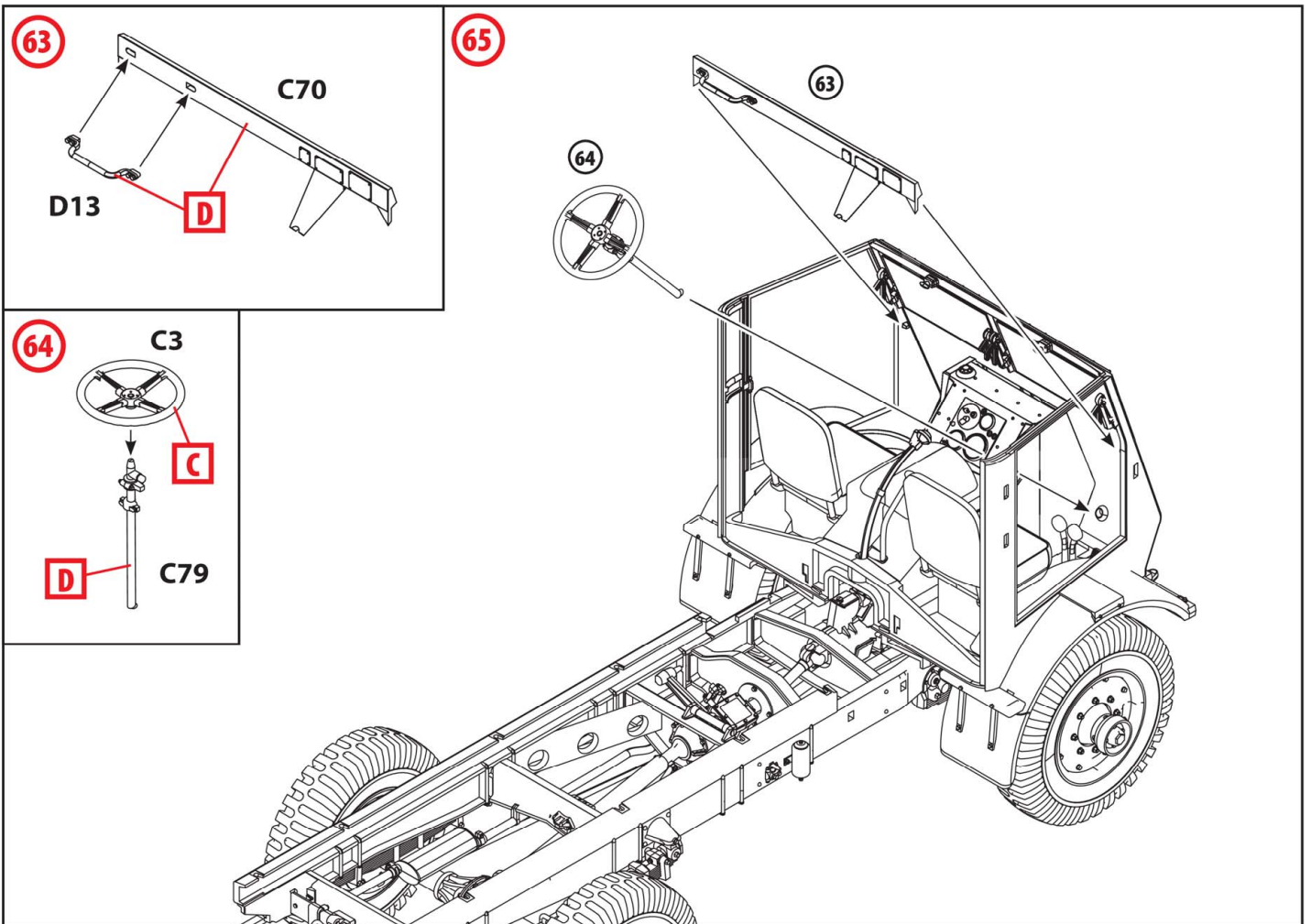
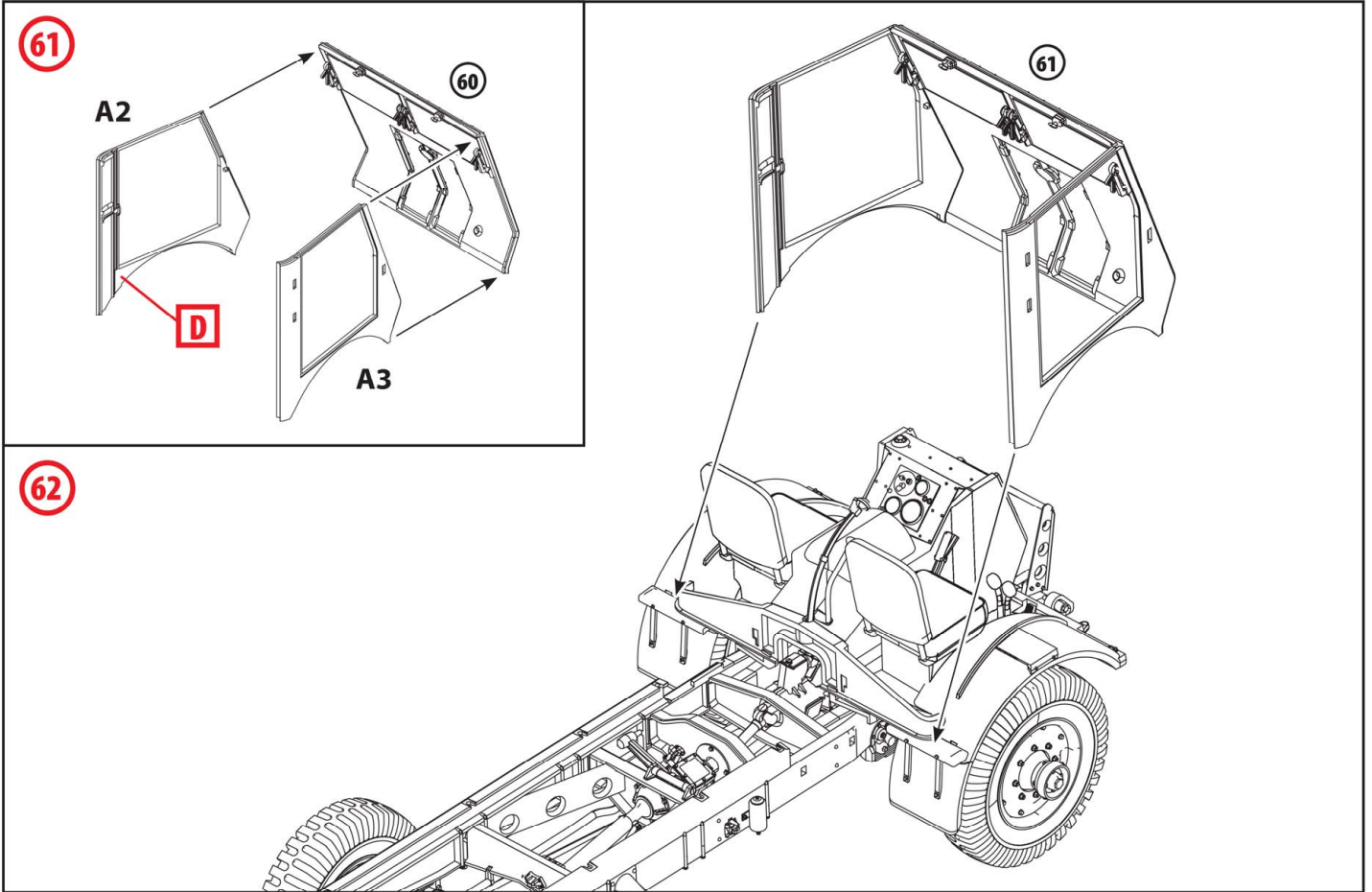

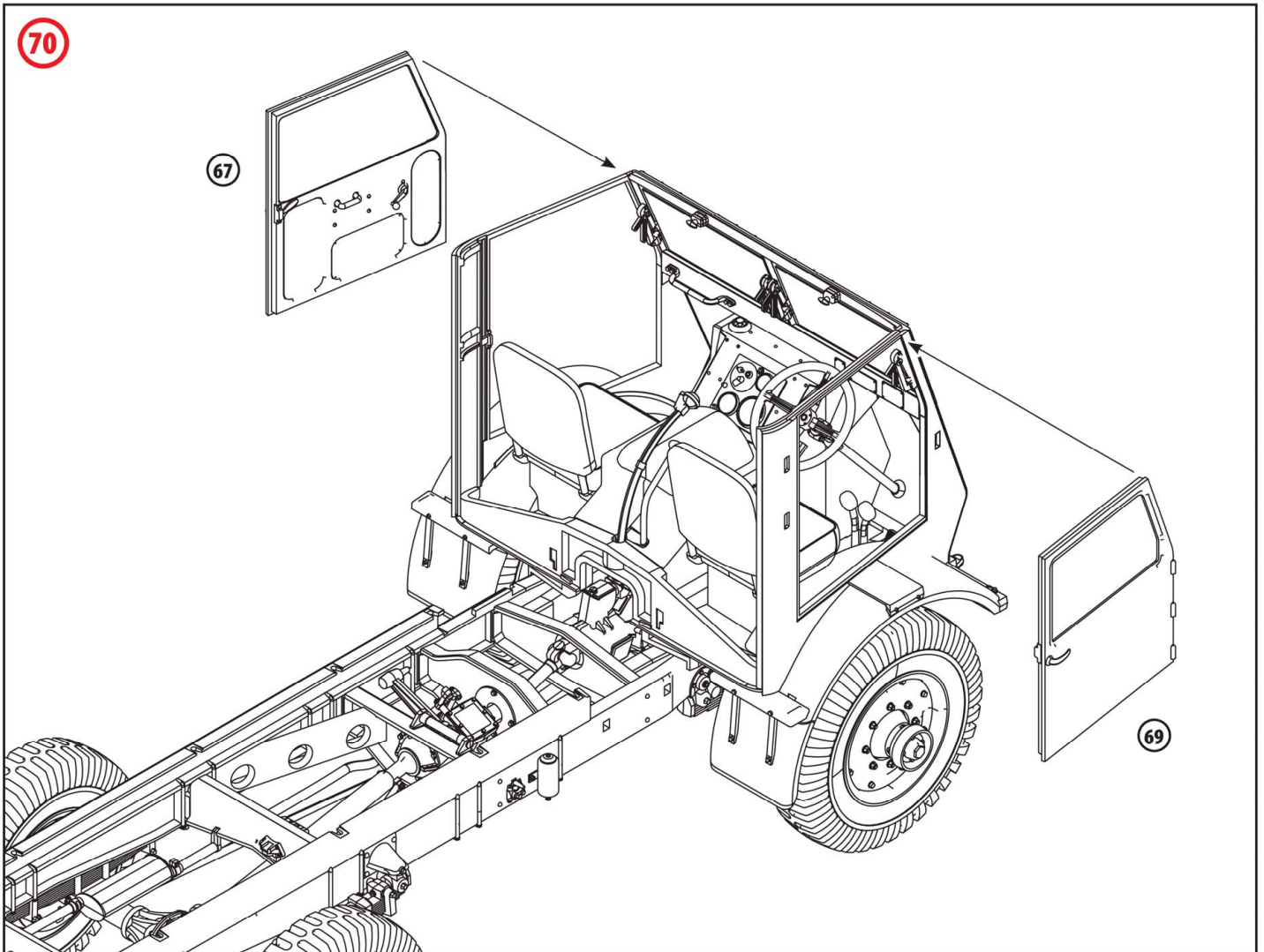
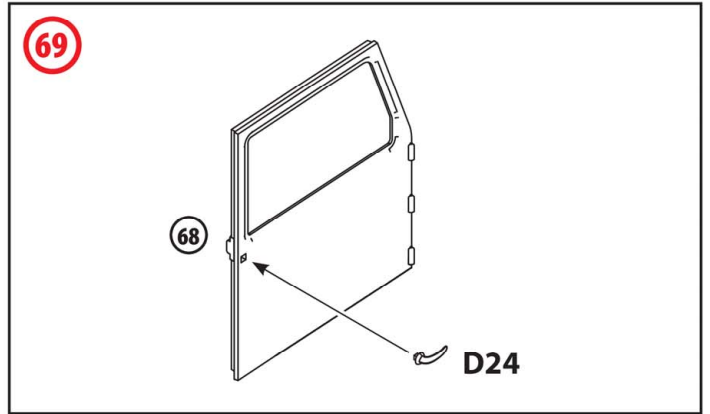
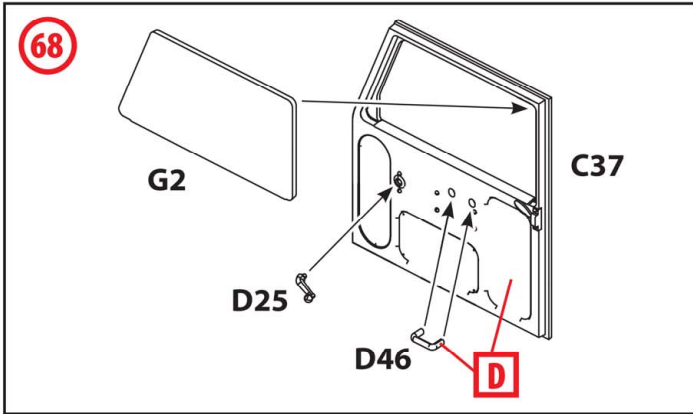
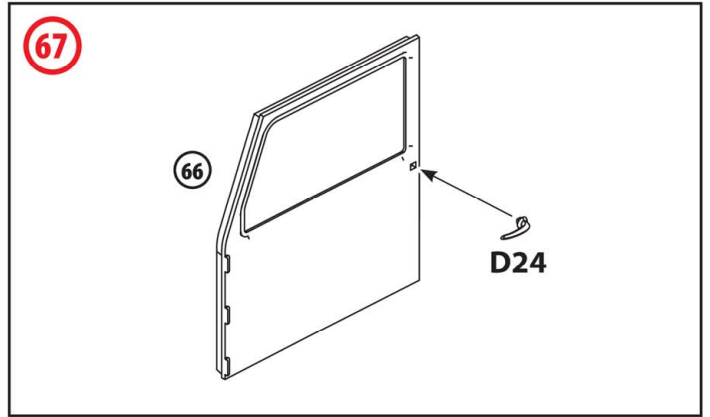
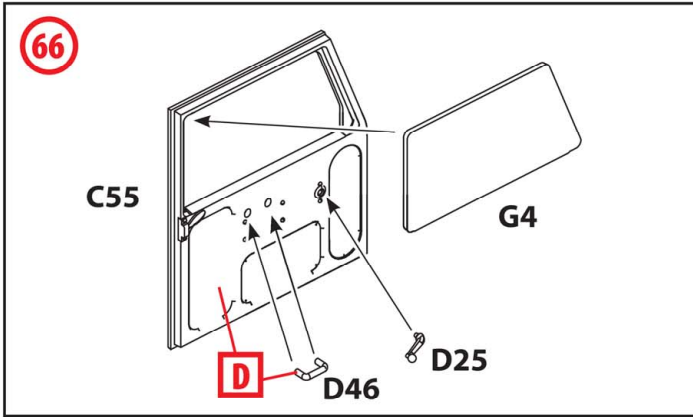

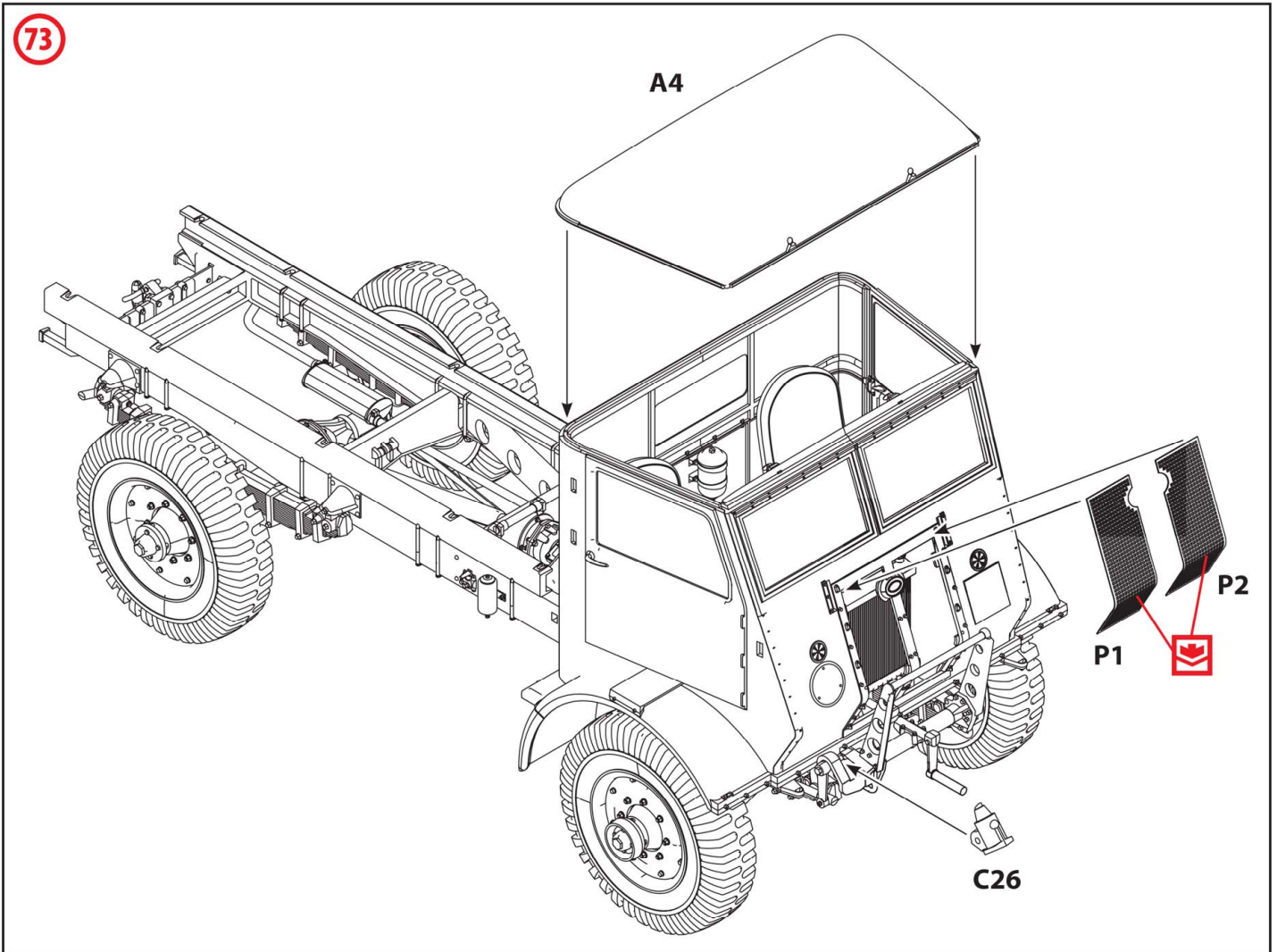
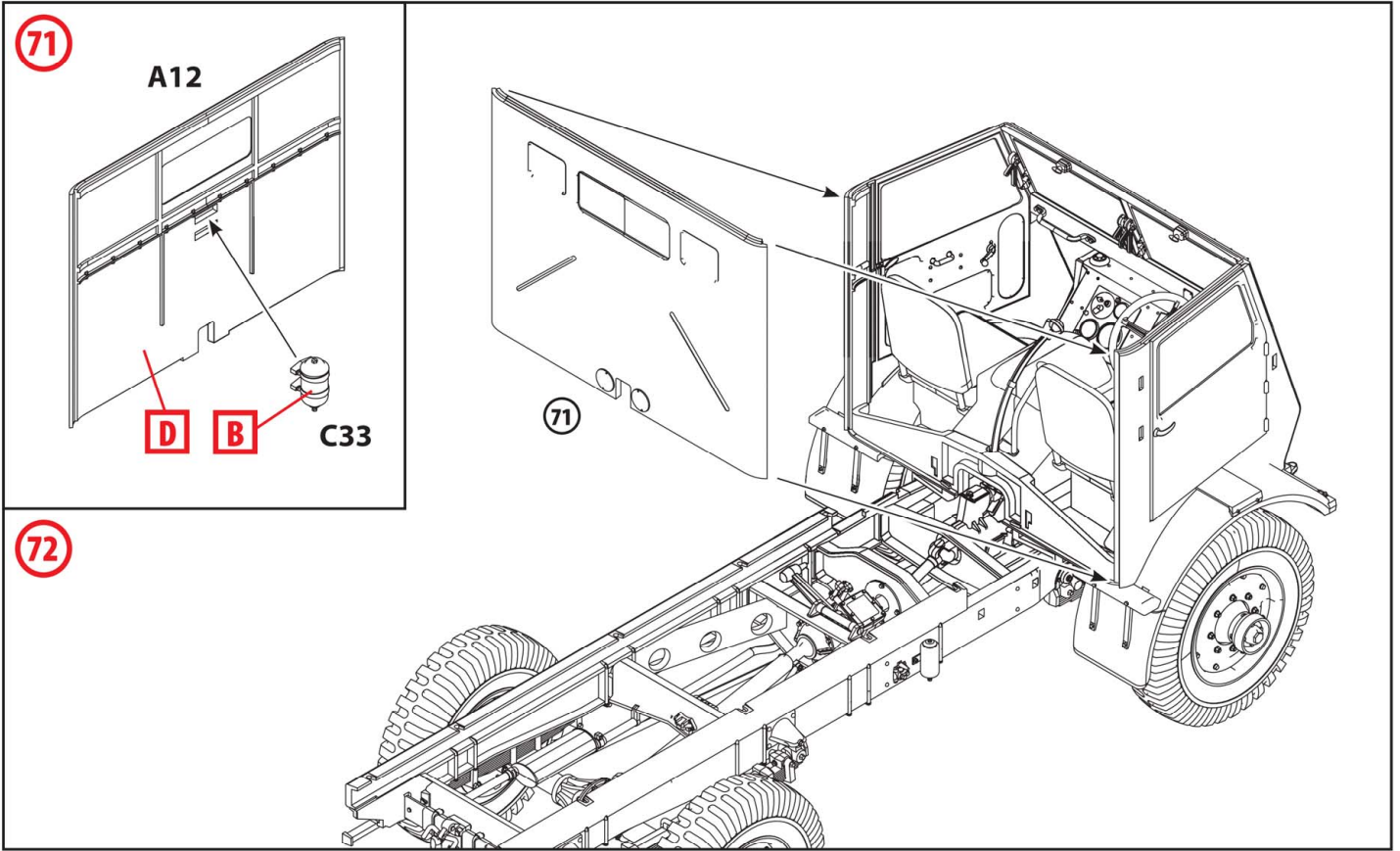

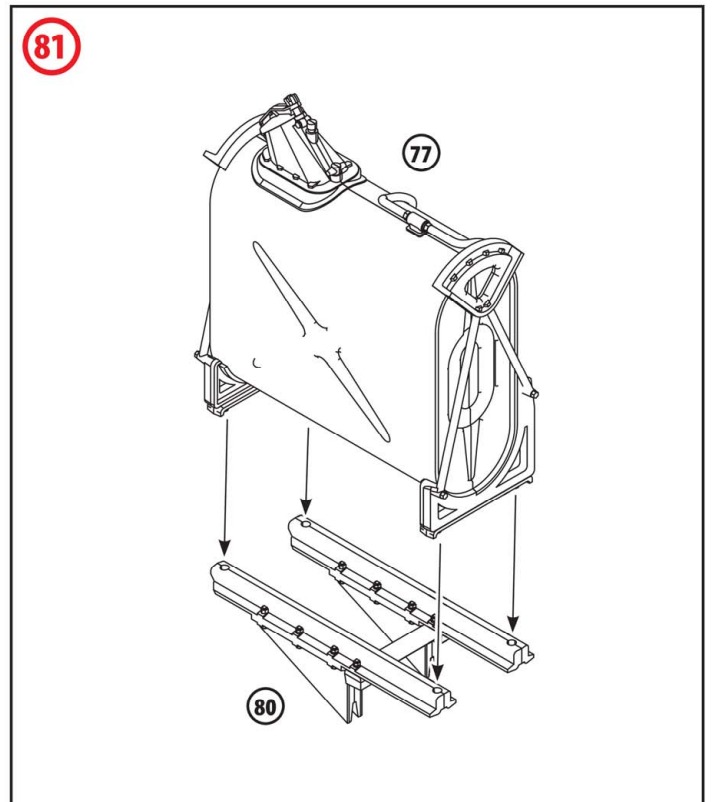
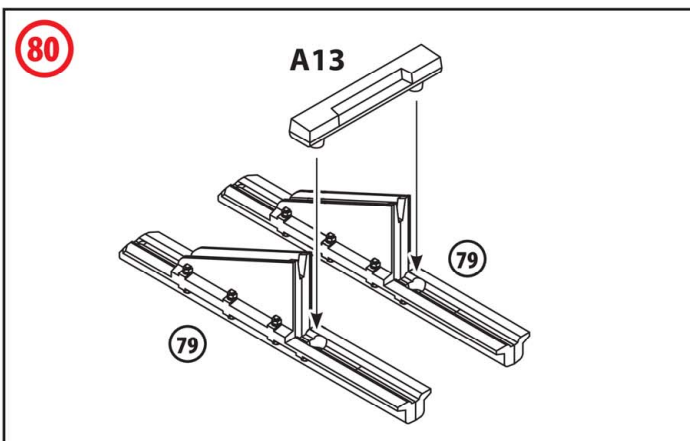
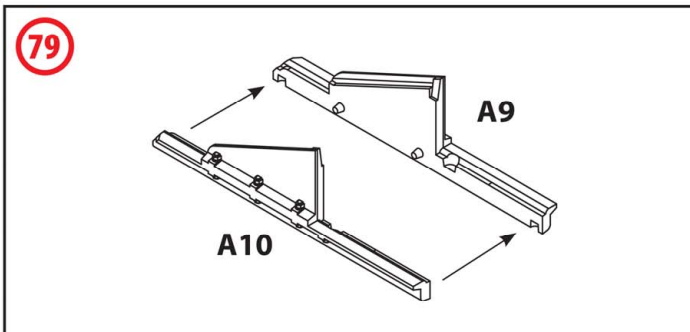
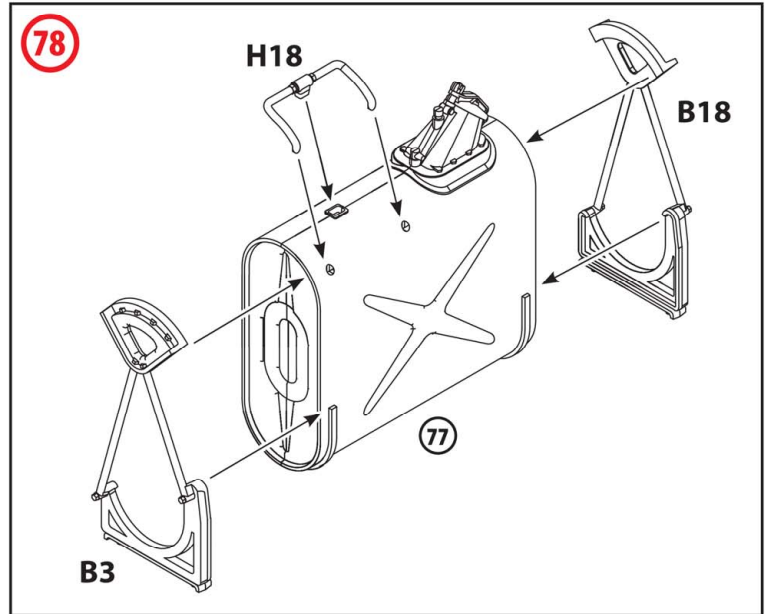
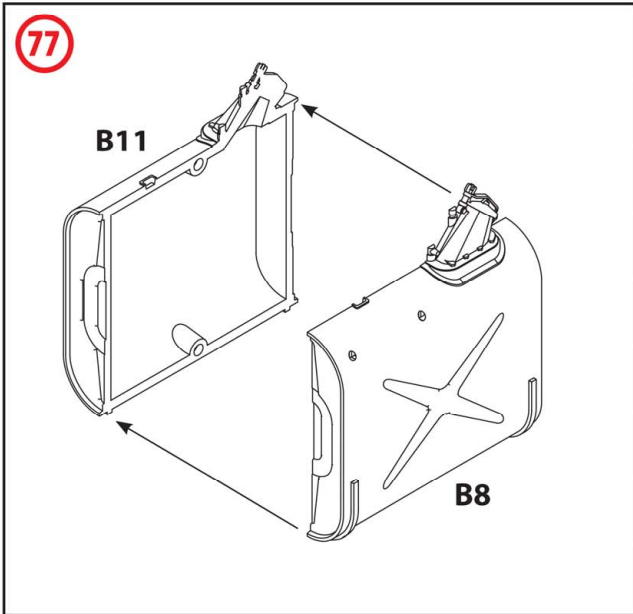
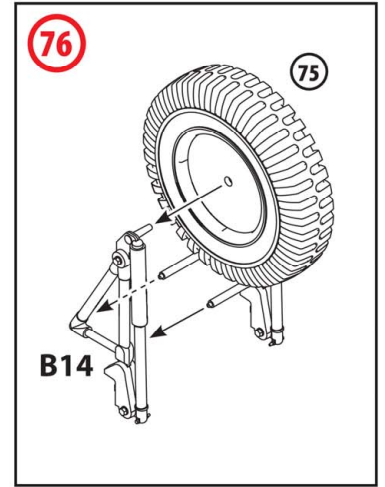
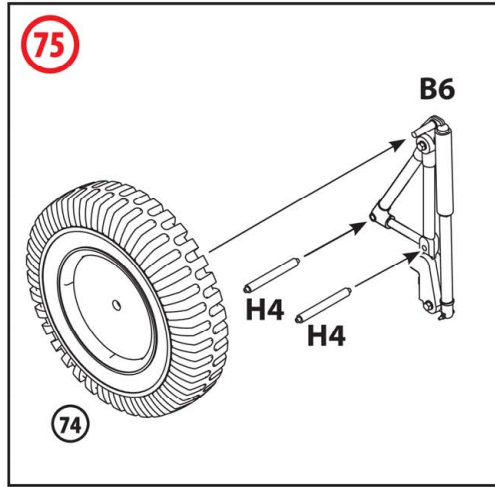
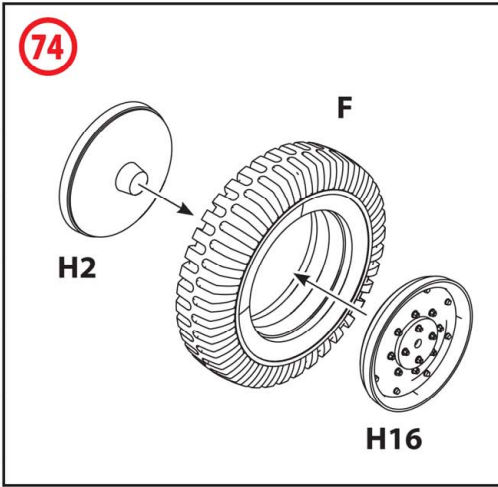

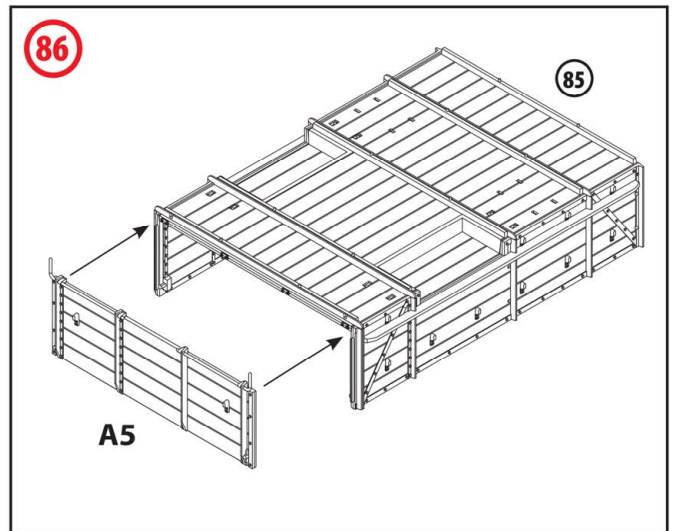
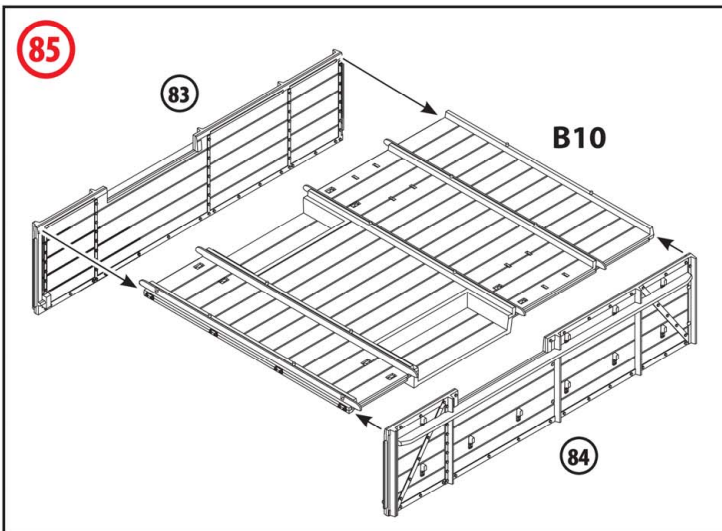
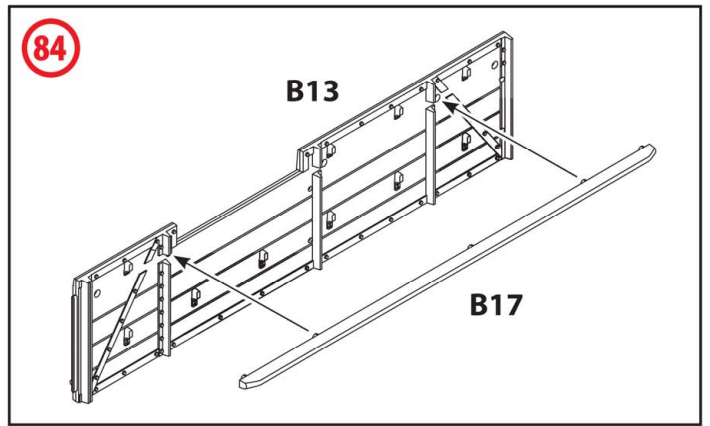
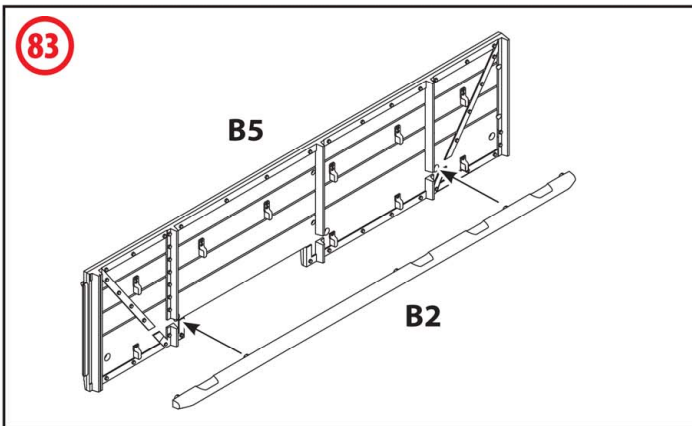
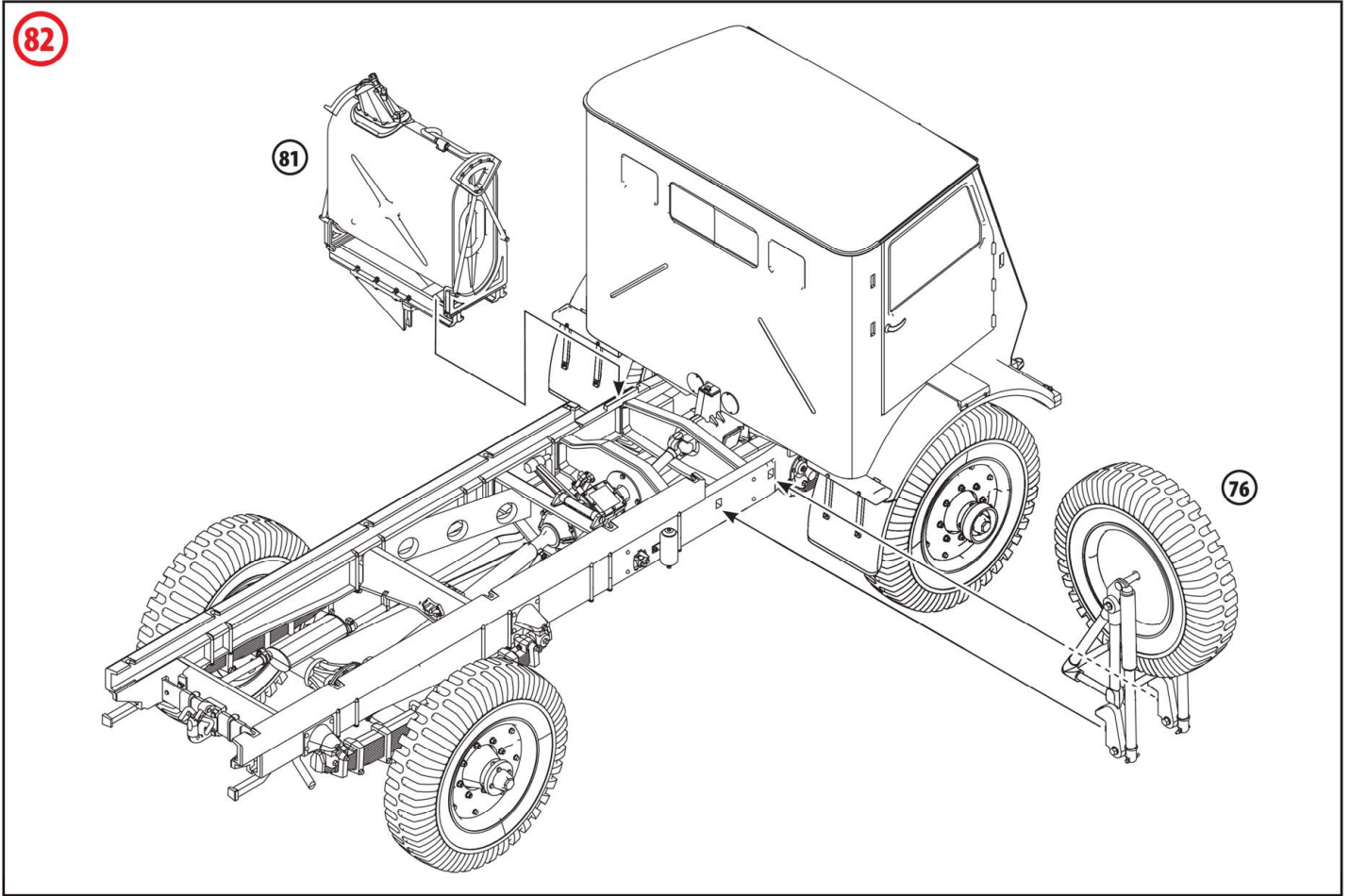

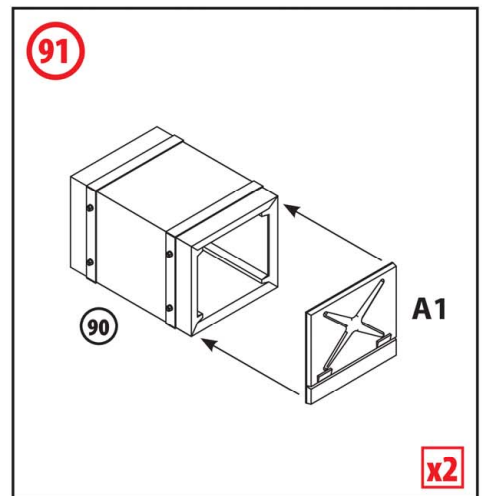
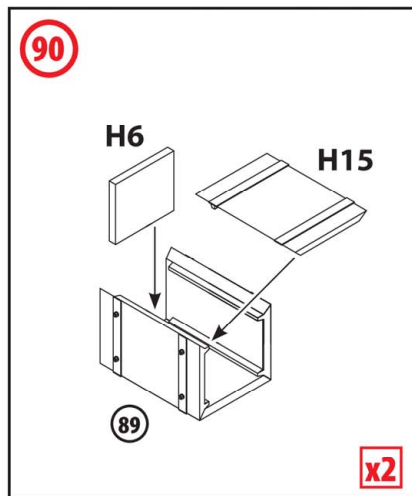
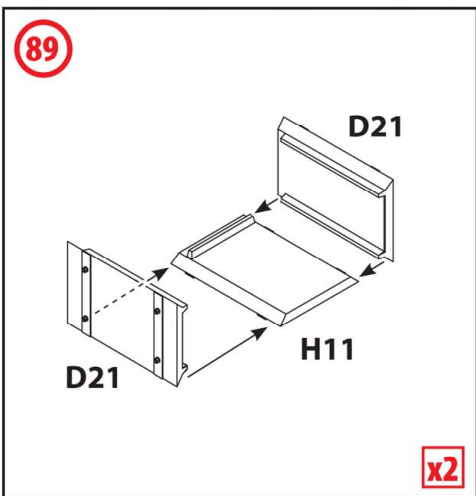
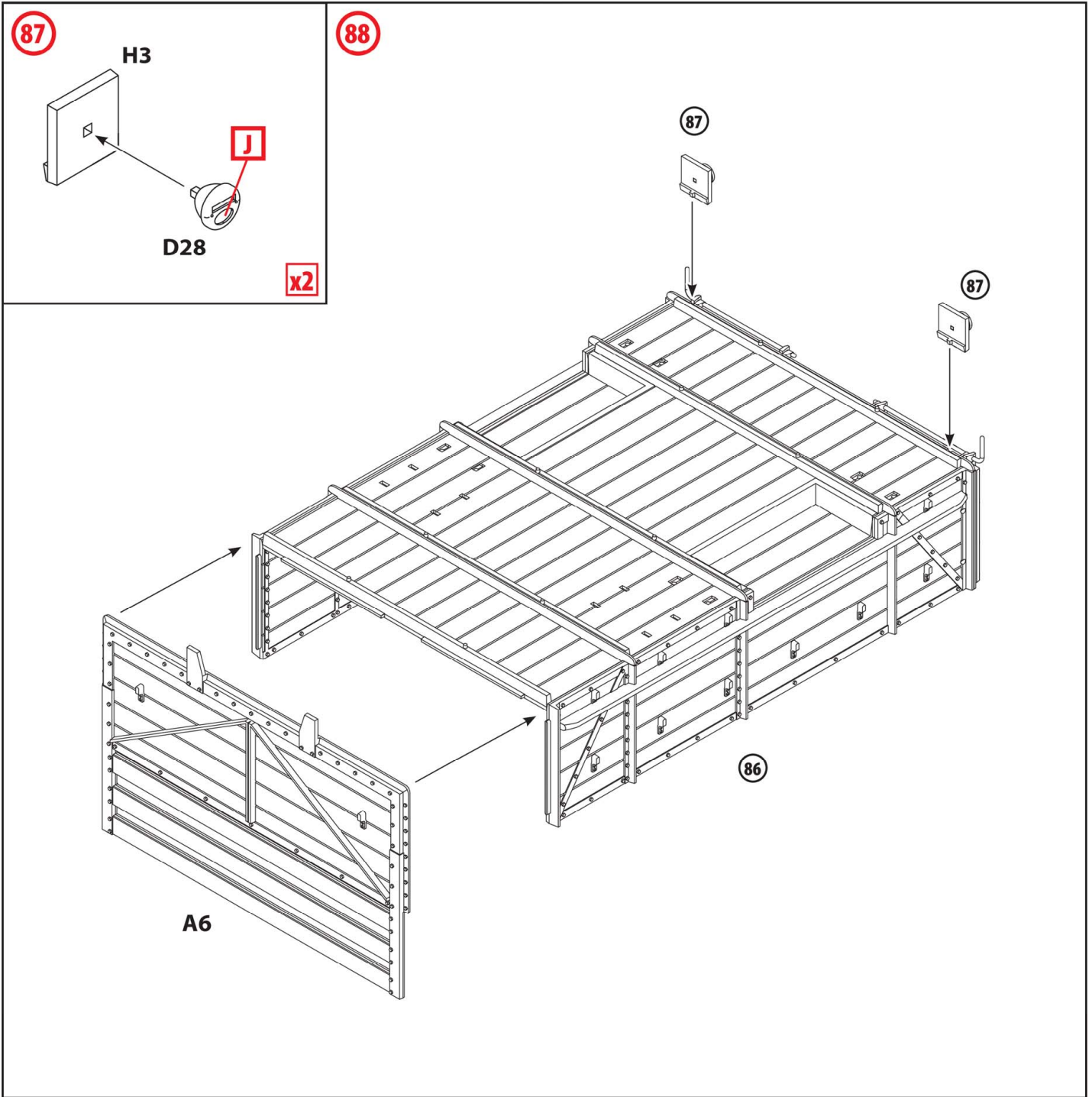

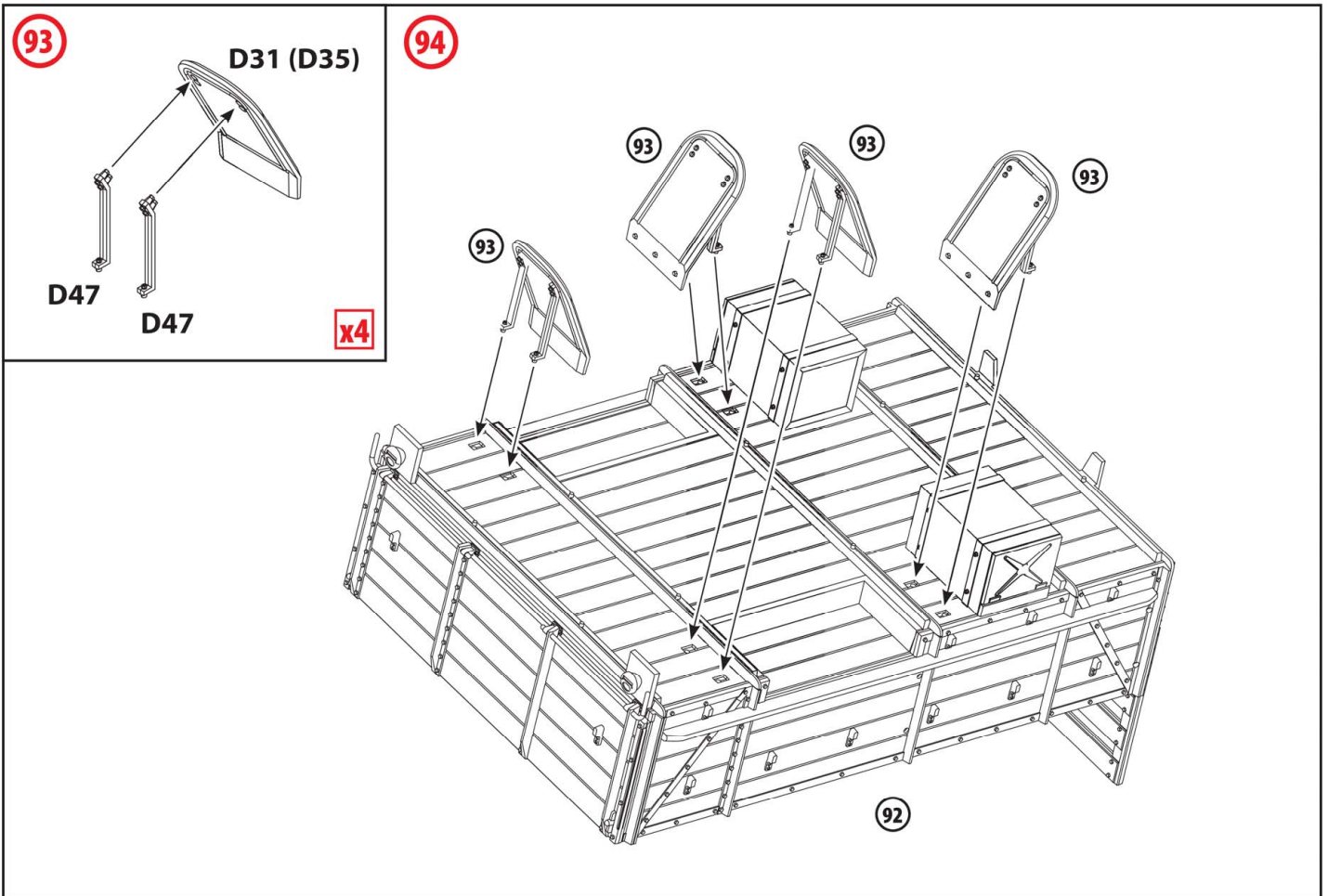
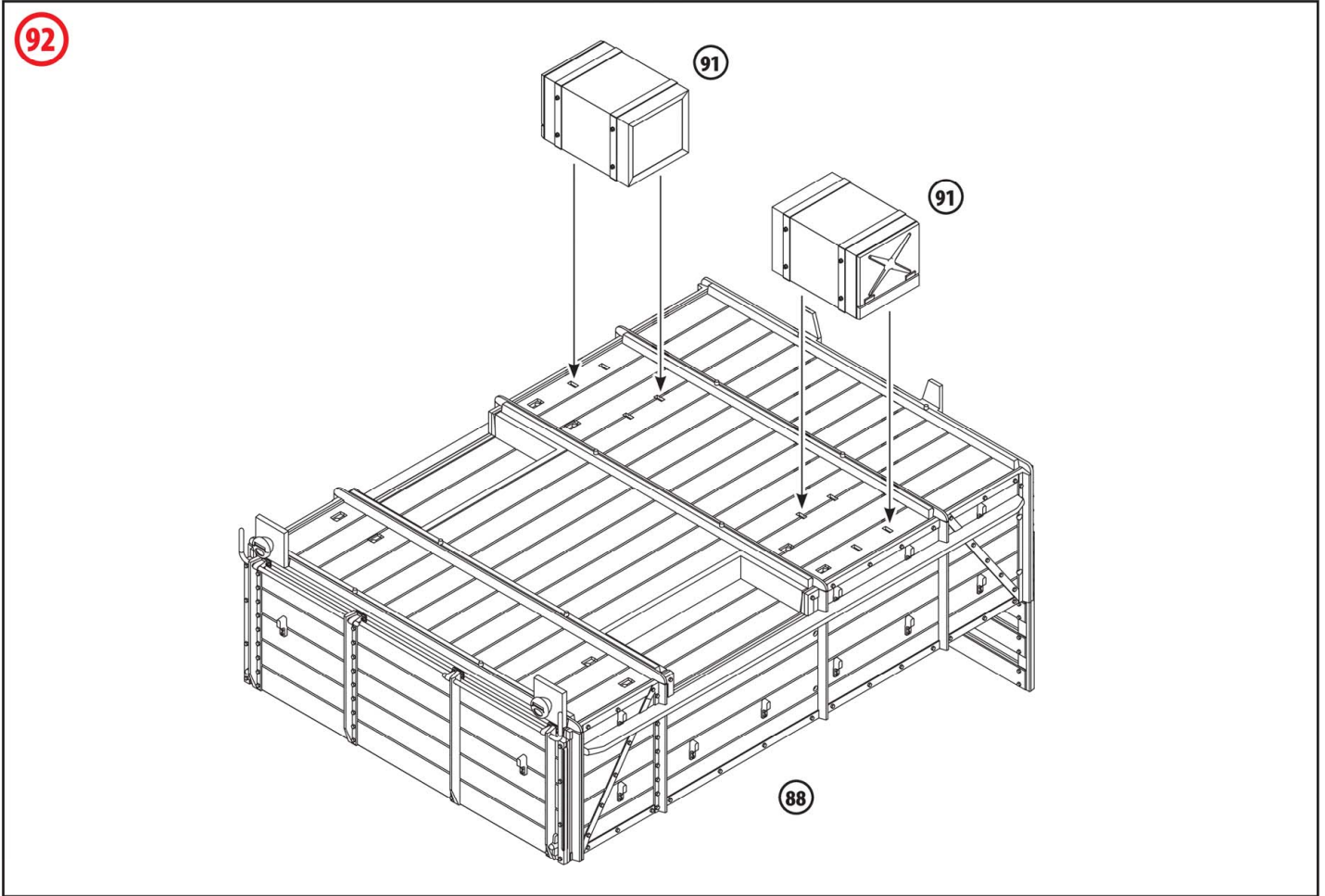

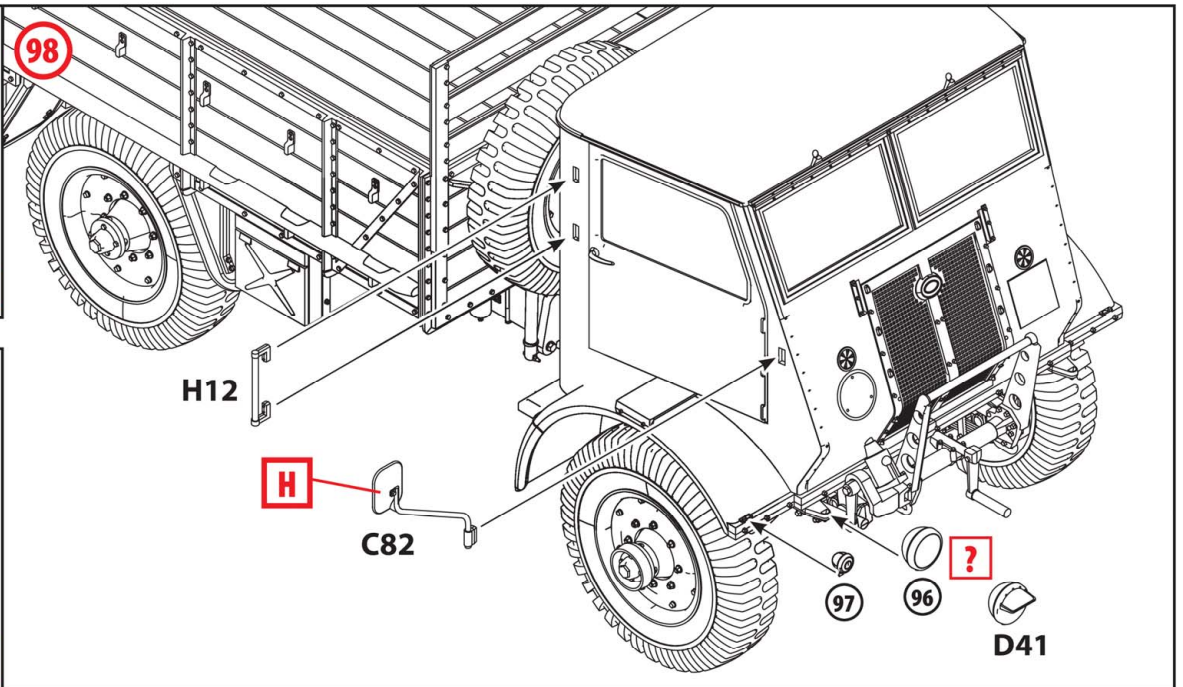
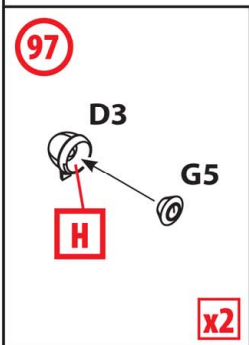
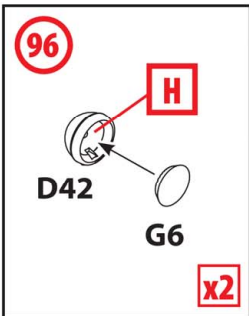
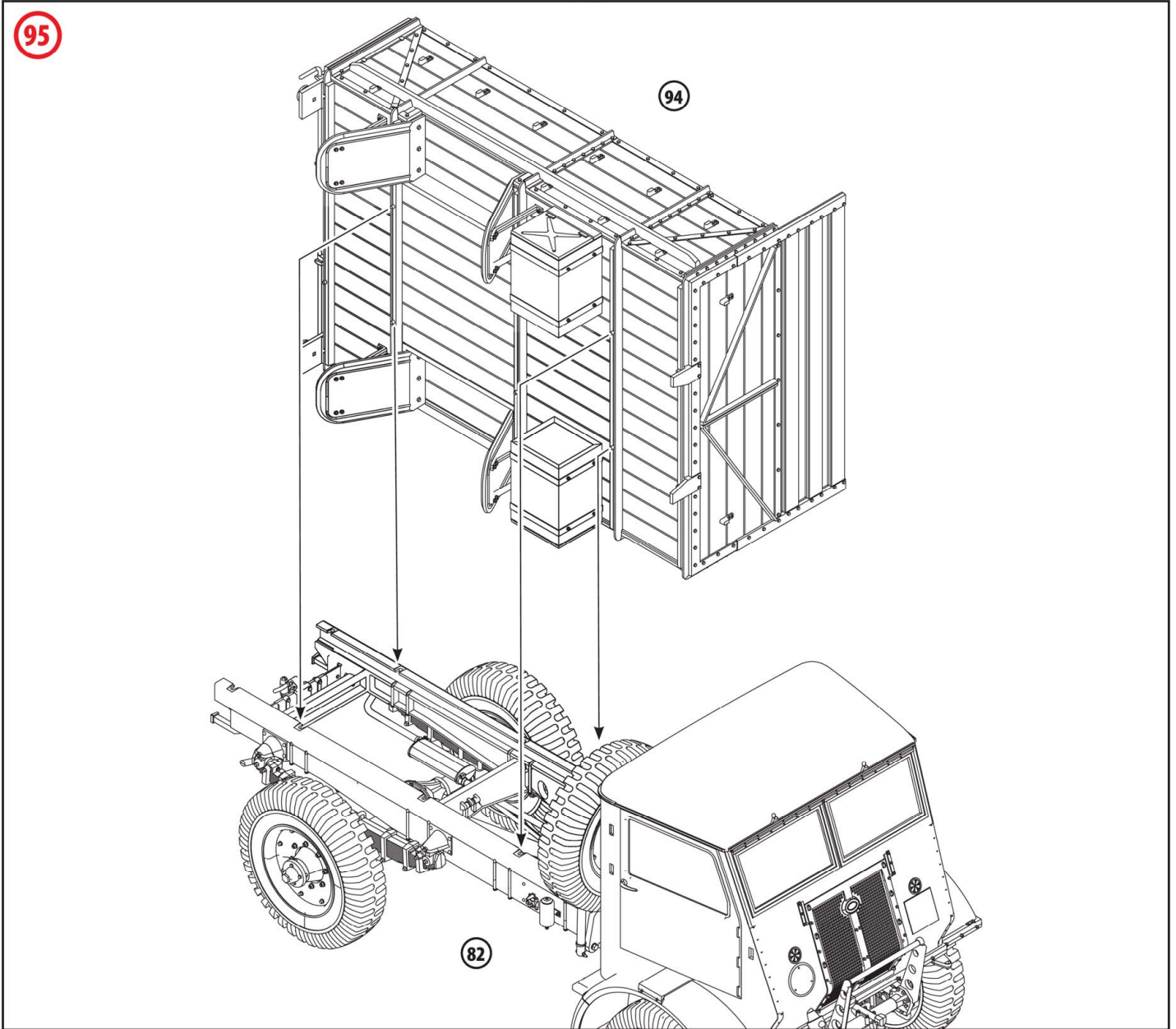

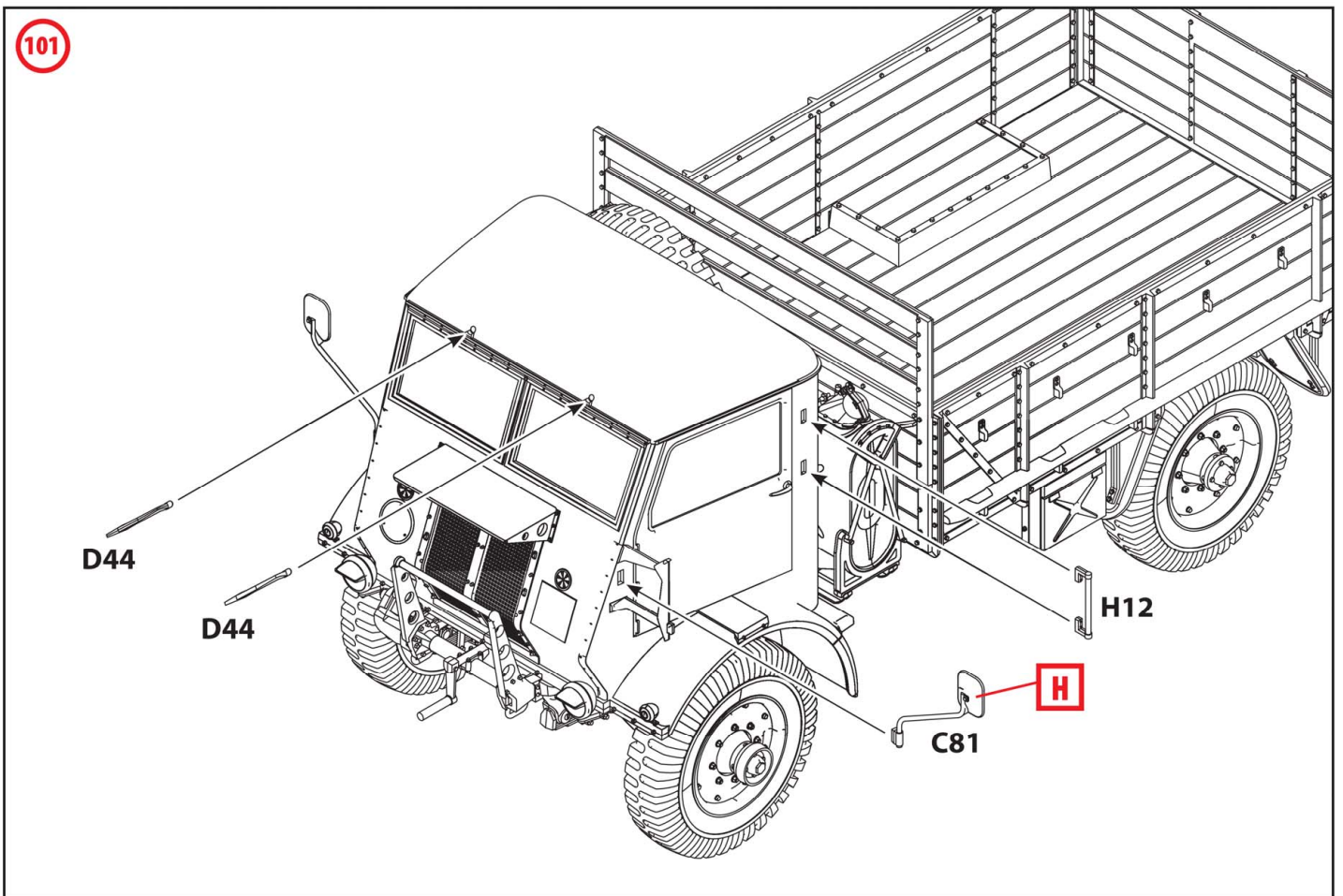
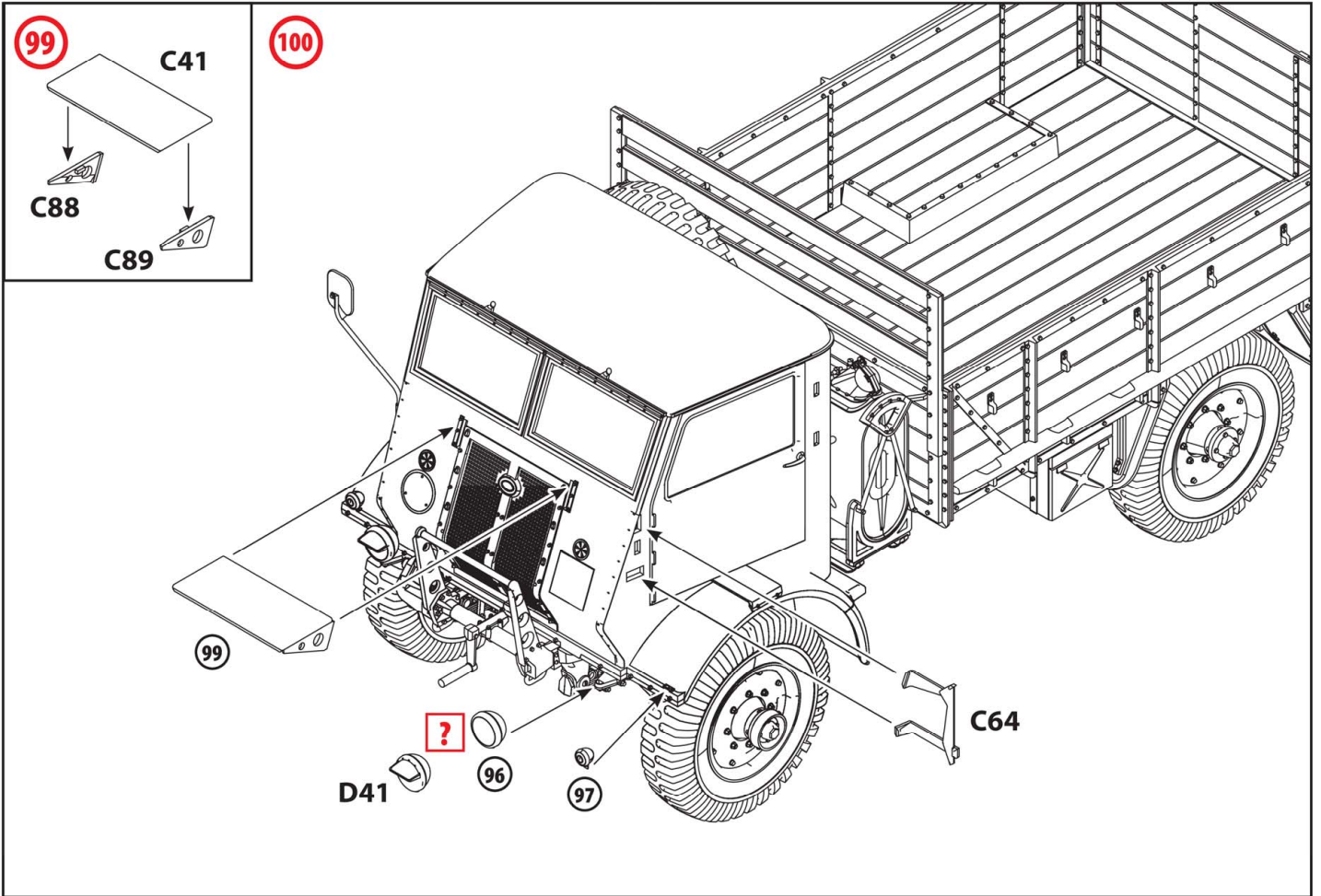

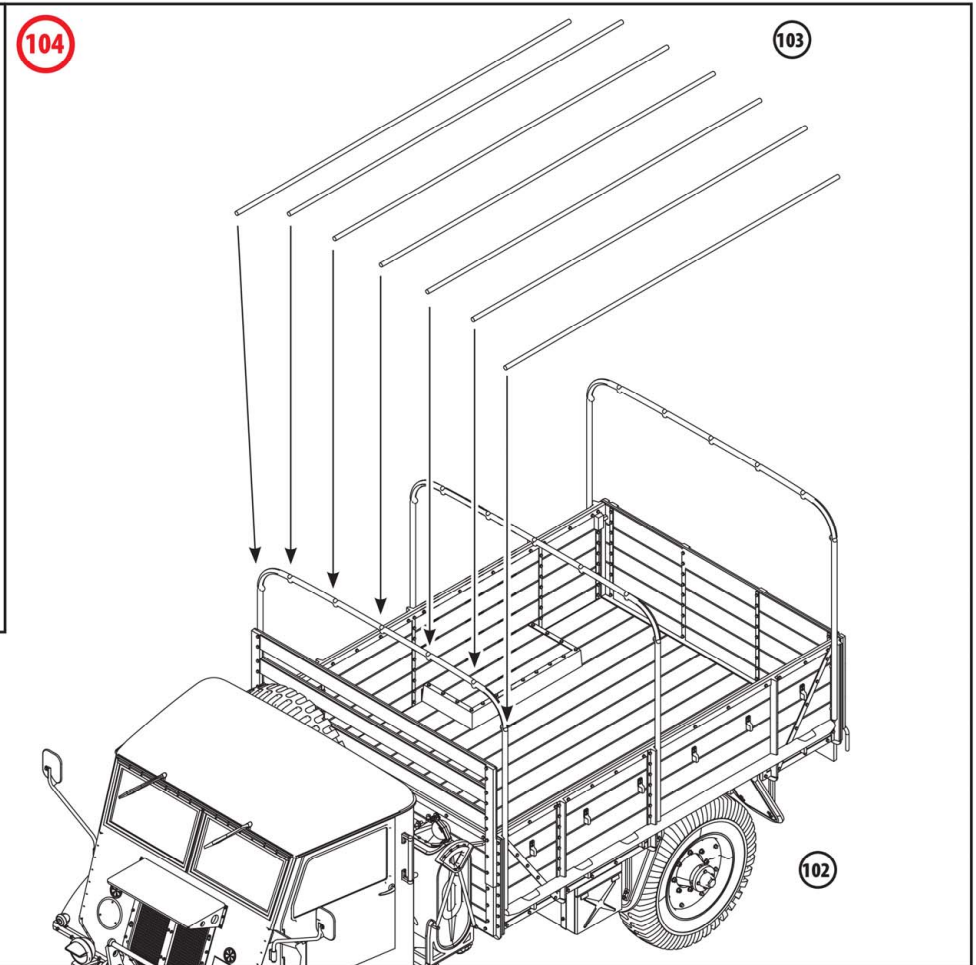
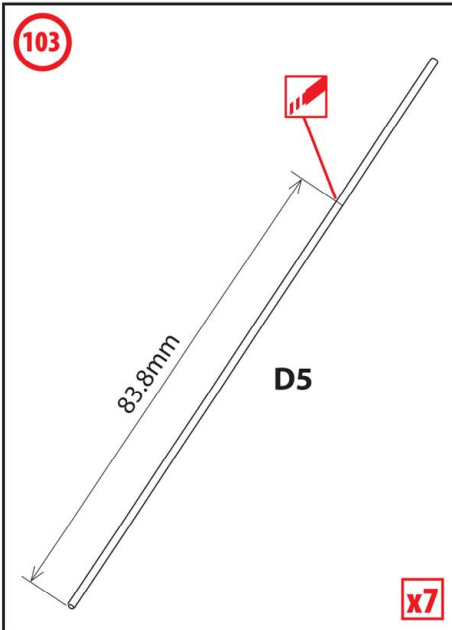
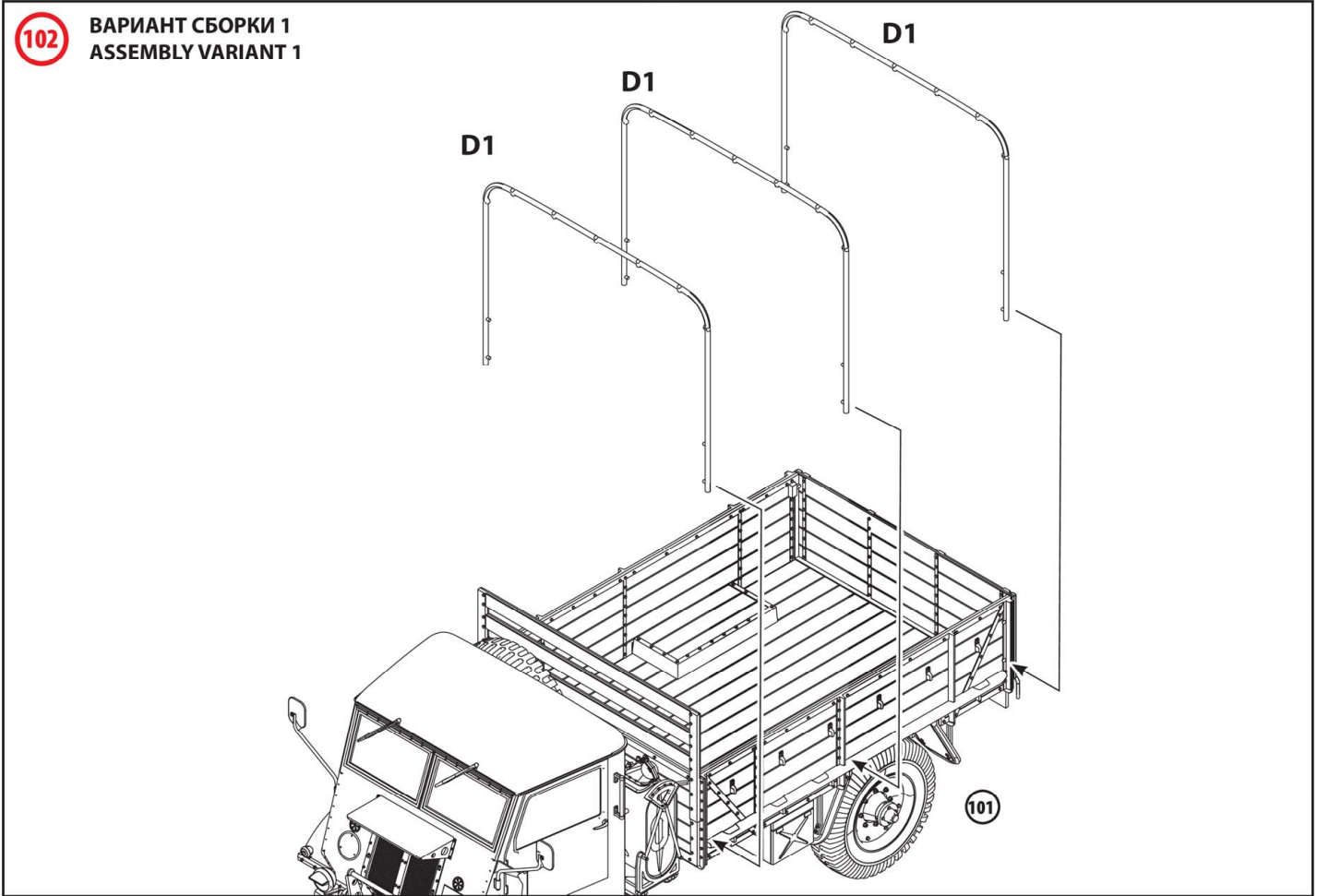

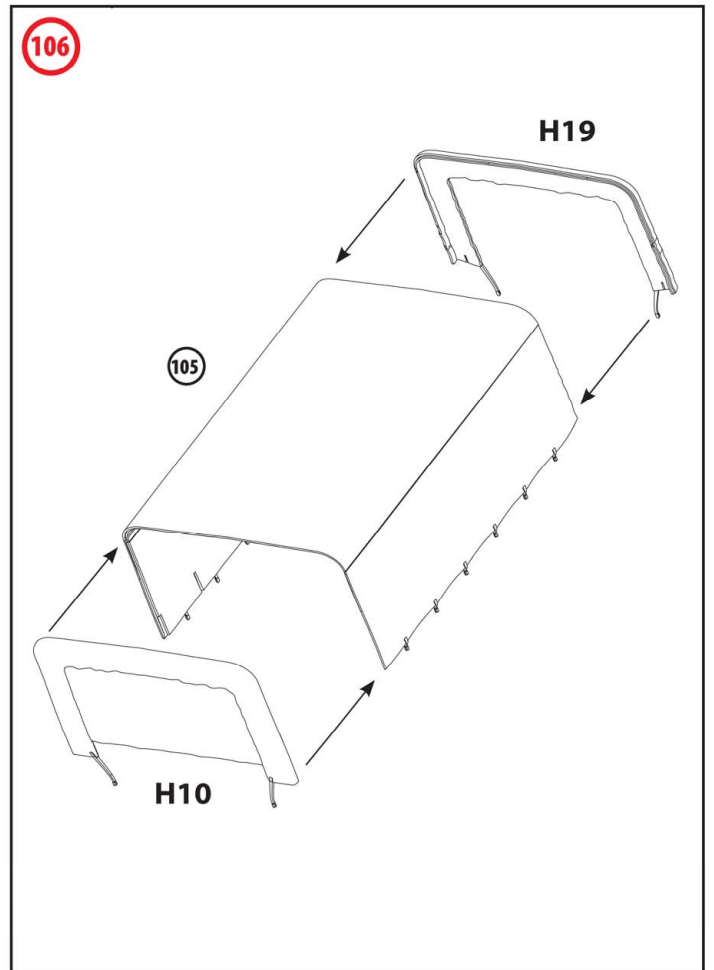
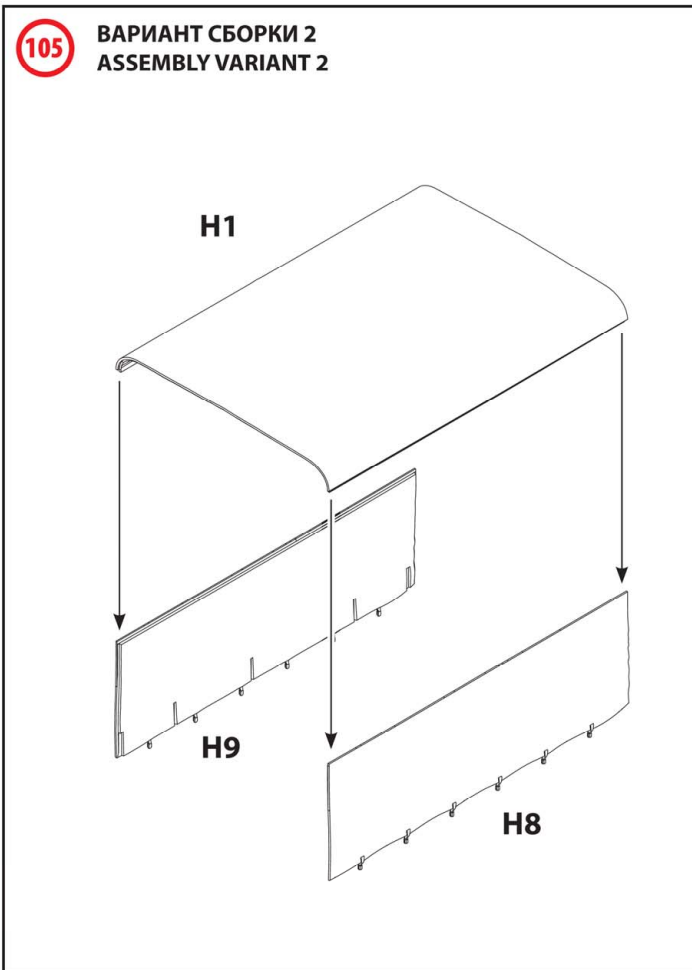
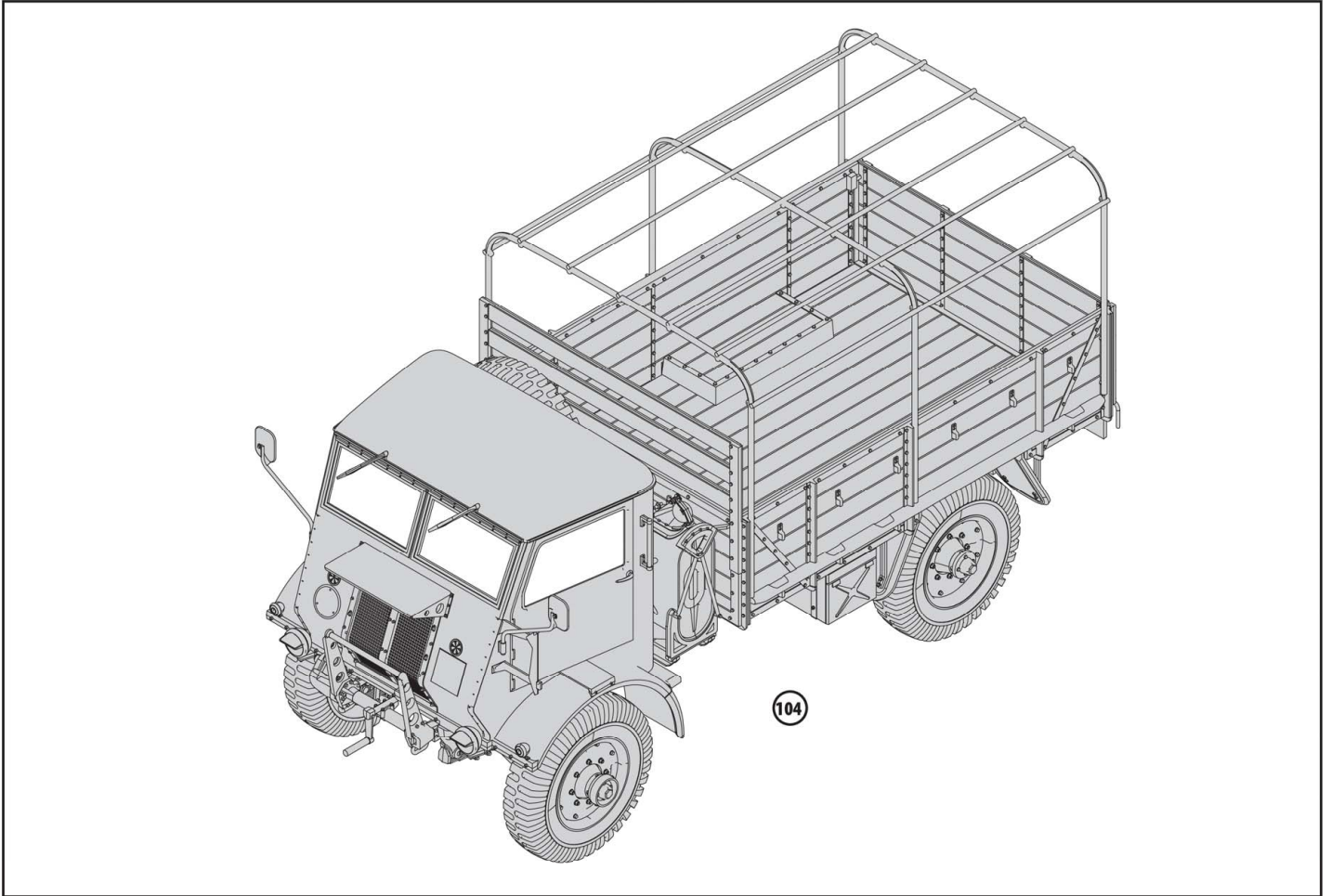

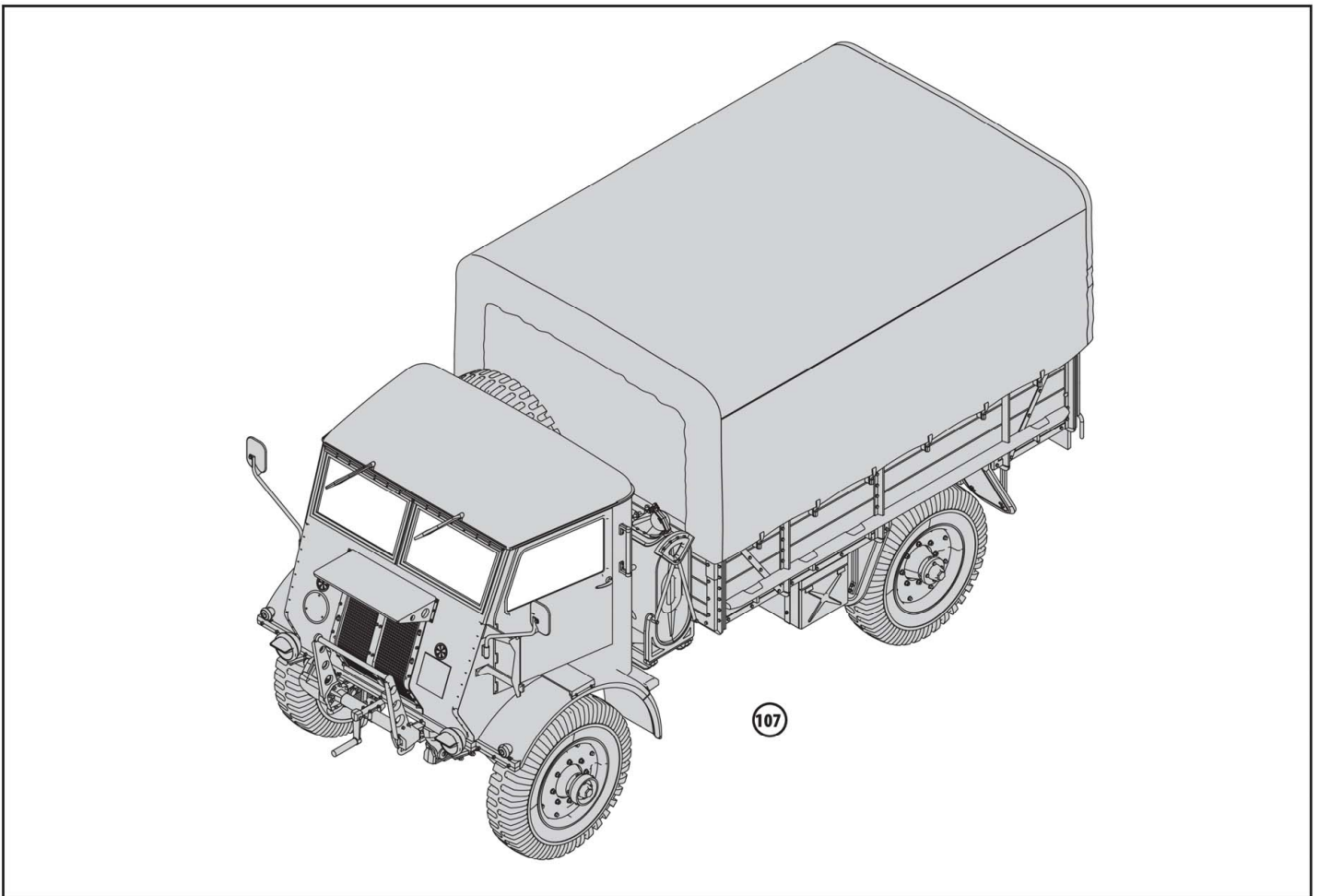
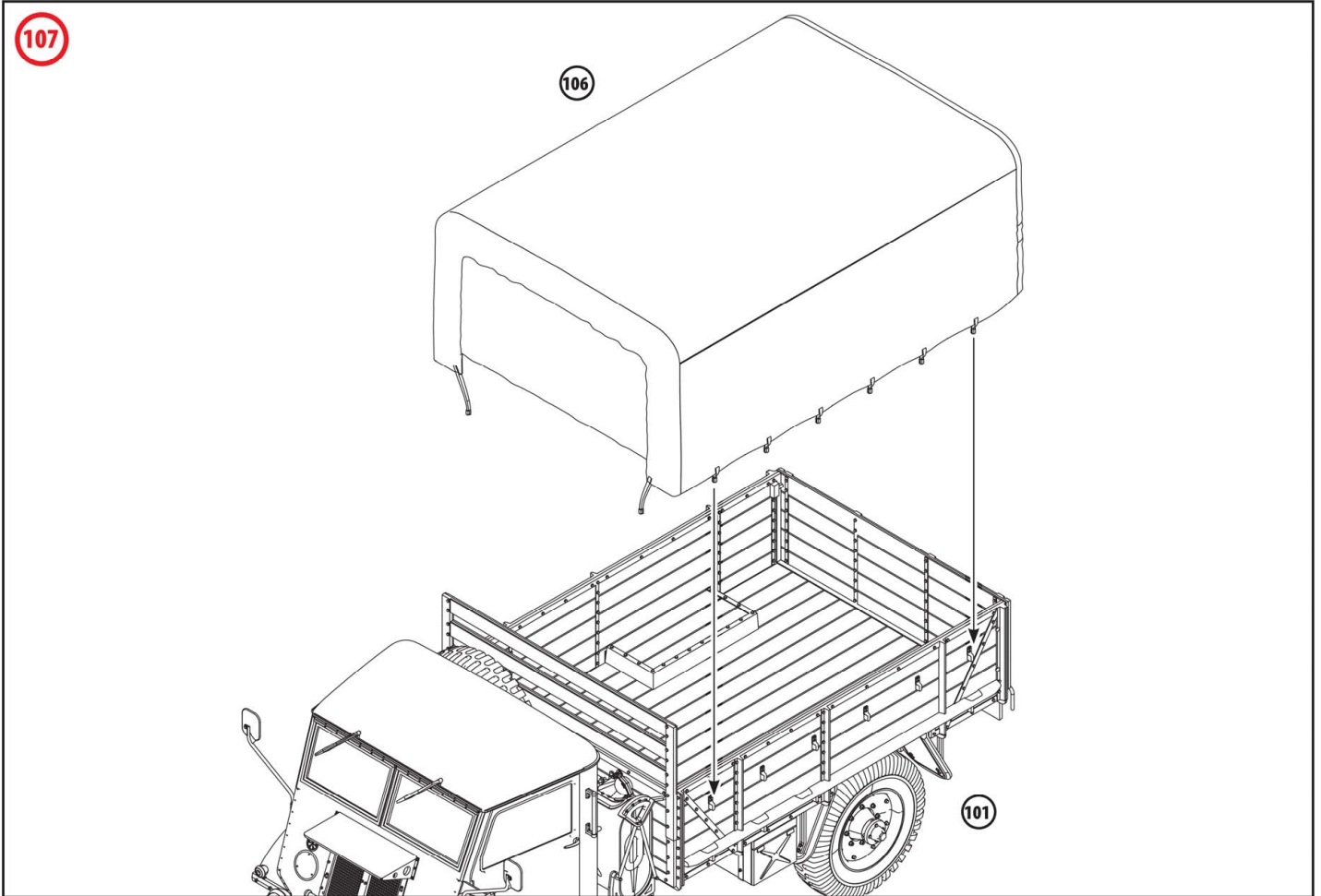

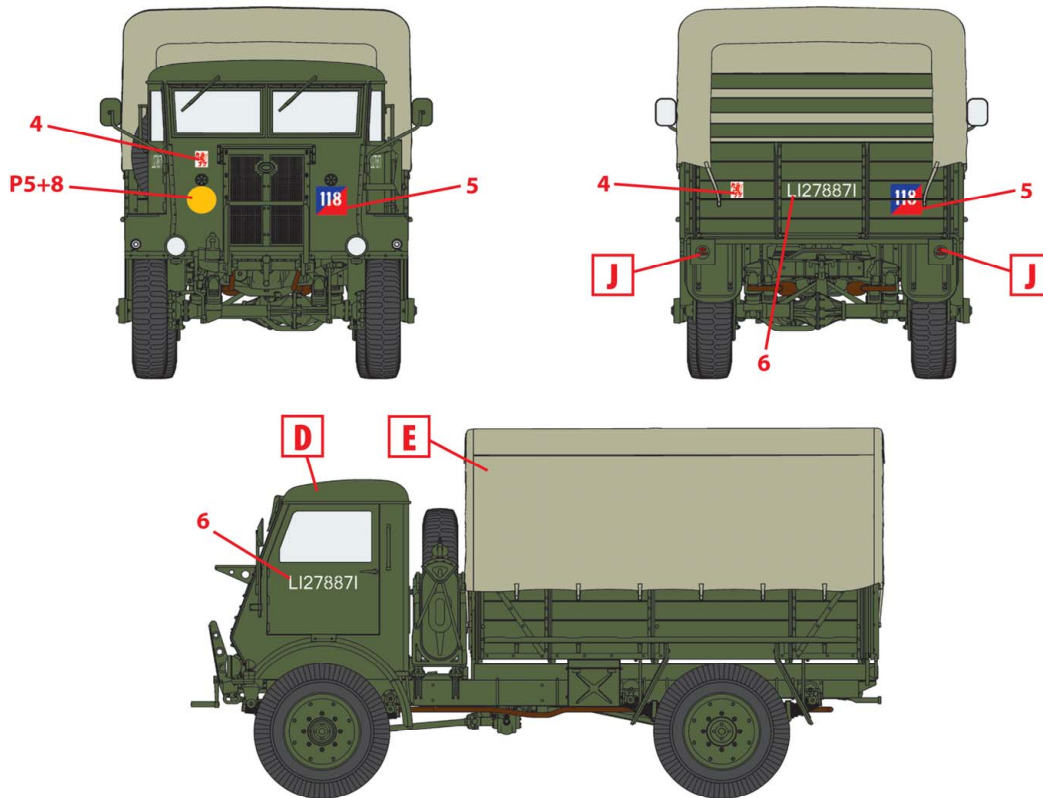

1. W.O.T. 8, 1-я Чехословацкая танковая бригада, Германия, весна 1945 г.
W.O.T. 8, 1st Czech Armoured Brigade, Germany, Spring 1945

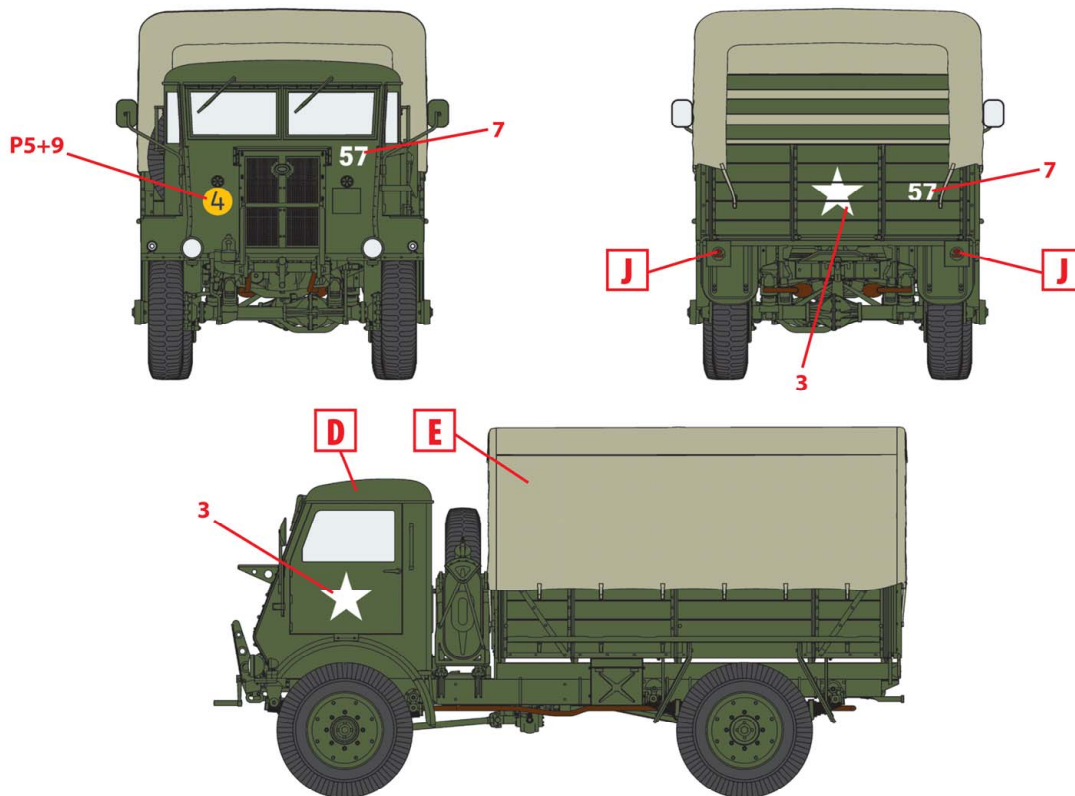

2. W.O.T. 8, Франция, лето 1944 г.
W.O.T. 8, France, Summer 1944

ООО ICM Холдинг
ул. Бориспольская 9, строение 64,
02099, Киев, Украина
Тел./факс: +38(044) 369 54 12
E-mail: export@icm.com.ua



ICM Holding
Borispolskaya, 9, build. 64,
02099, Kiev, Ukraine
Tel./Fax: +38(044) 369 54 12
E-mail: export@icm.com.ua