

AERMACCHI MB-326



MODELLO IN
SCALA RIDOTTA
MODELE
REDUIT

MODEL
KIT
MODELL IN
VERKL. MASSTAB

1/72

CAT. N. 10-011
MADE IN ITALY



DESCRIZIONE - Il progetto dell'MB 326 venne avviato verso la metà degli anni cinquanta, per realizzare un aereo scuola a reazione. Il primo volo ebbe luogo nel 1957 e il primo esemplare di serie fu consegnato all'Aeronautica Militare Italiana nel 1960. Altri acquirenti del velivolo furono: Alitalia, Tunisia, Ghana, Sud Africa, Australia, Argentina, Brasile, Zaire, Zambia, Dubai.

L'MB 326 è un biposto metallico, con motore Bristol Siddeley «VIPER». Ala medio bassa, con bordo d'attacco a leggera freccia. Allievo e istruttore siedono in tandem sotto un lungo tettuccio completamente trasparente.

Caratteristiche principali - Apertura alare: m. 10,56 m - Lunghezza: 10,65 m - Altezza: 3,72 m - Velocità massima: 871 km/h - Autonomia: 2445 km.

HISTORY - The project of MB 326 started in the middle of '50 years for the realization of a jet school airplane. The prototype flew in the 1957 and the first operative aircraft was delivered at the Italian Air Force in 1960. Other buyers were: Alitalia airline, Tunisia, Ghana, South Africa, Australia, Argentina, Brazil, Zaire, Zambia, Le Dubai.

The MB 326 is a two-seat with Bristol Siddeley «Viper» engine. Middle-low wing and leading edge with light arrow. Pupil and instructor are located in tandem under a long transparent canopy.

Technical data - Span 10,56 m - Length 10,65 m - Height 3,72 m - Max. speed 871 Km/h - Tactical radius 2.445 Km.

DESCRIPTION - Le projet du MB 326 vit le jour vers la milieu des années cinquante pour la réalisation d'un avion école à réaction. Le premier vol eut lieu en 1957 et le 1er exemplaire de série fut livré à l'aéronautique militaire italienne en 1960. Les autres acquéreurs de cet avion furent: la Compagnie Alitalia, la Tunisie, le Ghana, l'Afrique du Sud, l'Australie, l'Argentine, le Brésil, le Zaire, la Zambia, Dubai.

Le MB 326 est un bi-places métallique équipé d'un moteur Bristol Siddeley «Viper». Aile médiane à bord d'attaque en légère flèche, élève et instructeur sont assis en tandem sous un long cockpit complètement transparent.

Données technique - Envergure 10,56 m - Longueur 10,65 m - Hauteur 3,72 m - Vitesse maximum 871 Km/h - Autonomie 2.445 Km.

BESCHREIBUNG - Die Entwicklung der MB 326 wurde gegen Mitte der 50er Jahre begonnen, um ein Schulflugzeug mit Düsenantrieb zu schaffen. Der erste Flug fand 1957 statt, und das erste Serienexemplar wurde der italienischen Luftwaffe 1960 ausgeliefert. Weitere Käufer dieses Flugzeugtyps waren: Alitalia, Tunesien, Ghana, Südafrika, Australien, Argentinien, Brasilien, Zaire, Zambien und Dubai.

Die MB 326 ist eine Zweimann-Maschine aus Metall mit einem Bristol-Siddeley «VIPER»-Motor. Das Flugzeug hat mitteltiefe Pfeilflügel mit schwacher positiver Pfeilung. Schüler und Fluglehrer sitzen hintereinander unter einer langen, vollkommen durchsichtigen Kanzelhaube.

Haupteigenschaften - Spannweite 10,56 m - Länge 10,65 m - Höhe 3,72 m - Höchstgeschwindigkeit 871 km/h - Reichweite 2445 km.

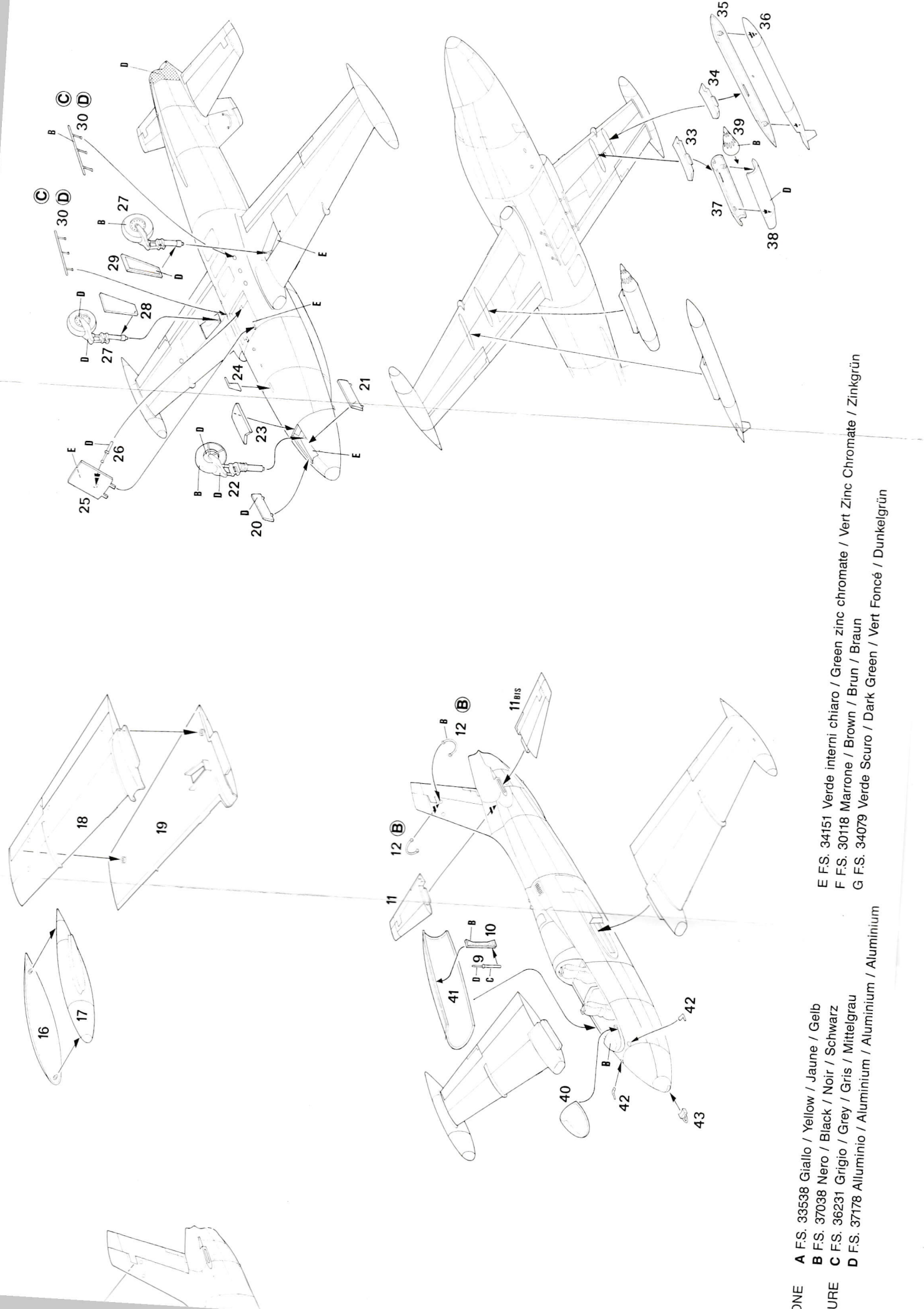

RAZIONE
 EINTURE
 EN

- A F.S. 33538 Giallo / Yellow / Jaune / Gelb
- B F.S. 37038 Nero / Black / Noir / Schwarz
- C F.S. 36231 Grigio / Grey / Gris / Mittelgrau
- D F.S. 37178 Alluminio / Aluminium / Aluminium / Aluminium

- E F.S. 34151 Verde interni chiaro / Green zinc chromate / Vert Zinc Chromate / Zinkgrün
- F F.S. 30118 Marrone / Brown / Brun / Braun
- G F.S. 34079 Verde Scuro / Dark Green / Vert Foncé / Dunkelgrün

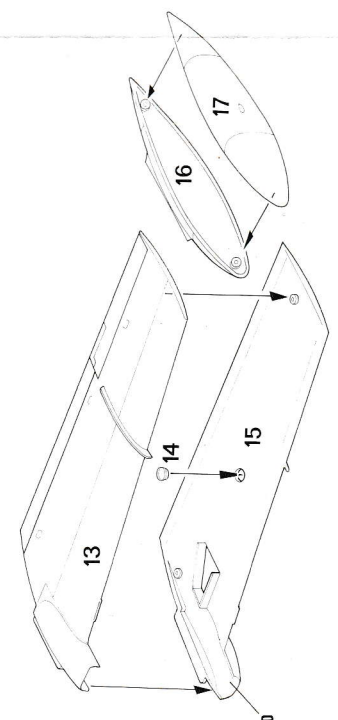
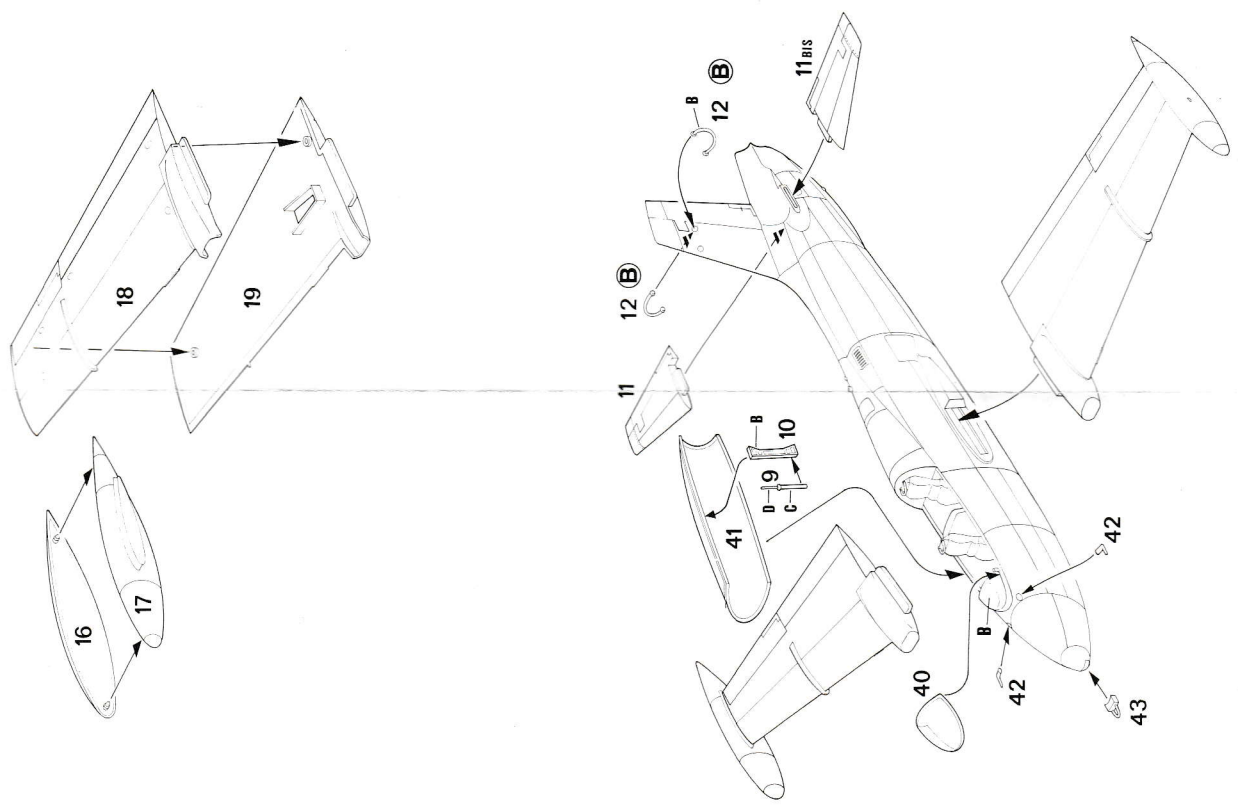
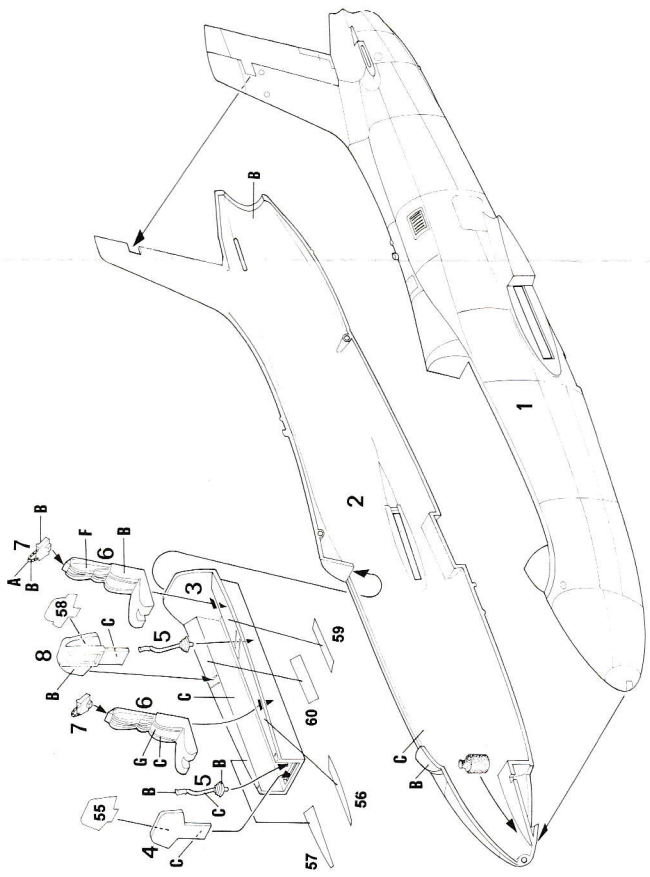

ISTRUZIONI PER LA COLORAZIONE
 PAINT INSTRUCTIONS
 INSTRUCTIONS POUR LA PEINTURE
 BEMALUNGS ANWEISUNGEN

A F.S. 33538 Giallo / Yellow / Jaune / Gelb
 B F.S. 37038 Nero / Black / Noir / Schwarz
 C F.S. 36231 Grigio / Grey / Gris / Mittelgrau
 D F.S. 37178 Alluminio / Aluminium / Aluminium / Aluminium

E F.S. 34151 Verde interni chiaro / Green zinc chromate / V
 F F.S. 30118 Marrone / Brown / Brun / Braun
 G F.S. 34079 Verde Scuro / Dark Green / Vert Foncé / Dunkelgrün

Aermacchi, MB-326
 Scuola Volo Basico Iniziale
 MI, Italian Air Force

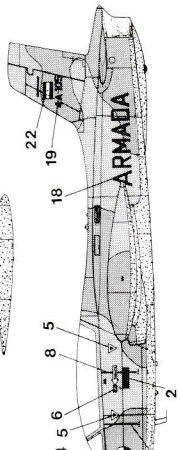
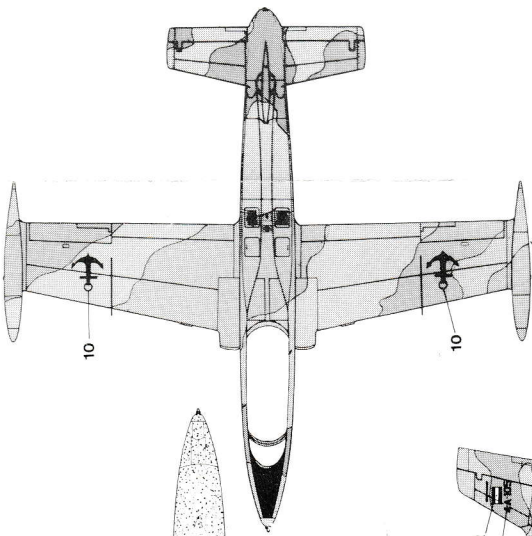
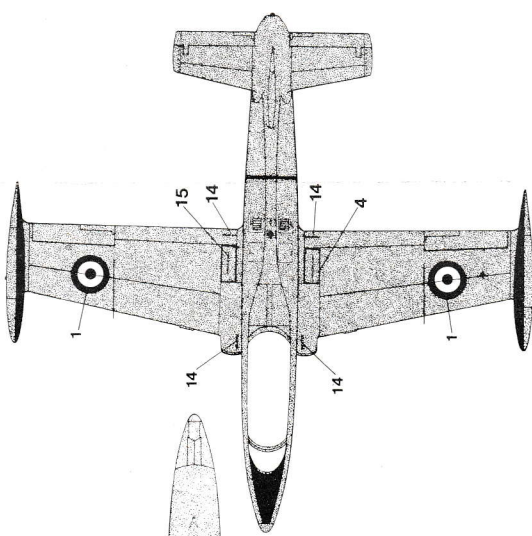
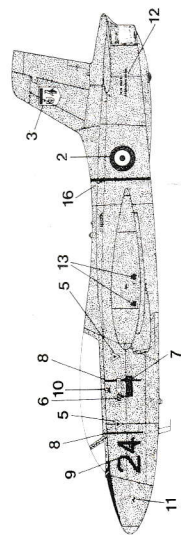

Aermacchi, MB-326 IMPALA MK I
 n. 83° Squadron, SAAF

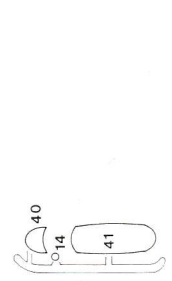
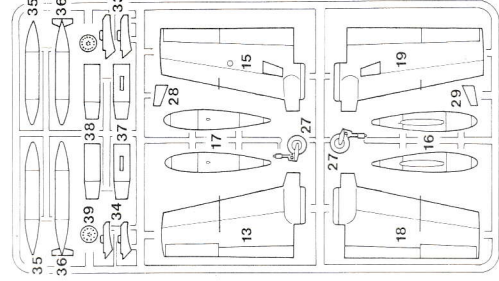
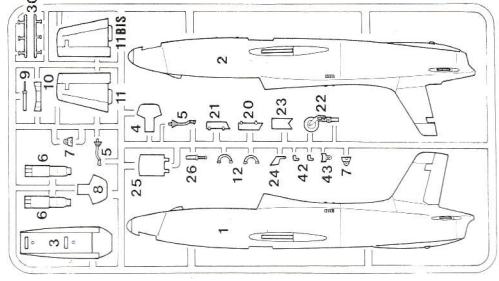
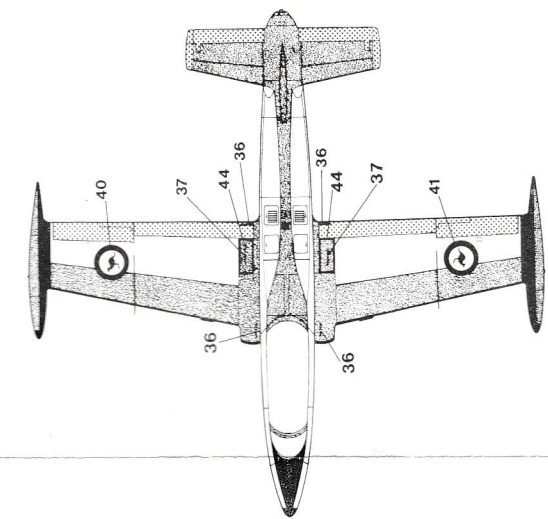
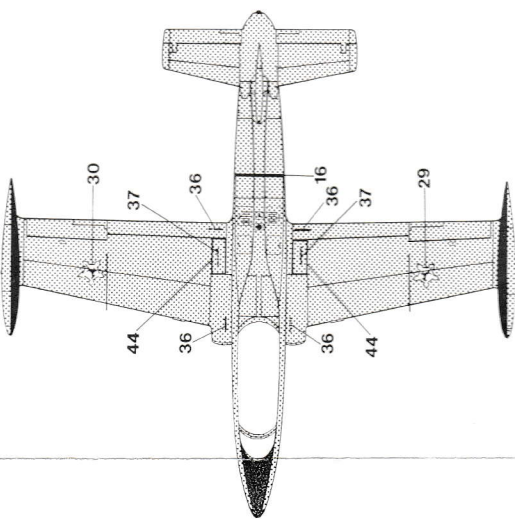
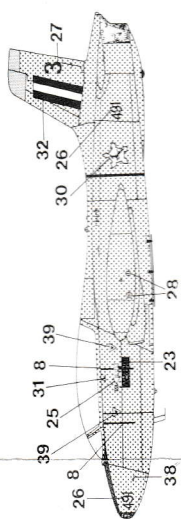
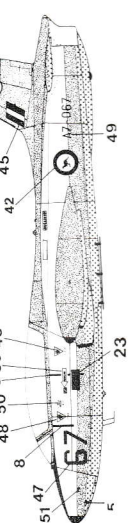
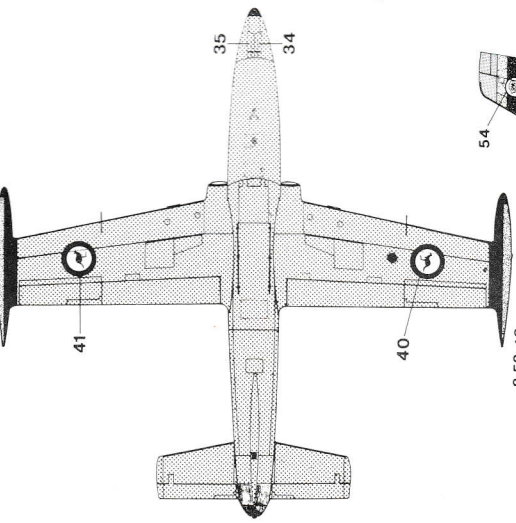
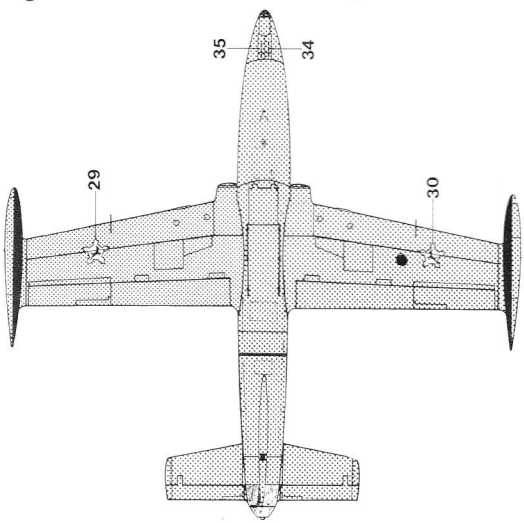

©

- FS. 11246
 Bianco
 White
 Orange
 Orange
- FS. 17875
 Bianco
 White
 Bianco
 Weiss
- FS. 27038
 Nero
 Black
 Nero
 Schwarz
- FS. 37178
 Alluminio
 Aluminium
 Alluminio
 Aluminium
- FS. 30316
 Marrone
 Light brown
 Marrone
 Braun
- FS. 34079
 Verde scuro
 Dark green
 Verde scuro
 Dunkelgrün
- FS. 36473
 Grigio
 Light grey
 Grigio
 Hellgrau
- FS. 36440
 Grigio
 Light grey
 Grigio
 Hellgrau
- FS. 28538
 Giallo
 Yellow
 Jaune
 Gelb

AERMACCHI, MB-326 GB, PELICANO
 Escuadrilla de Ataque, Argentina

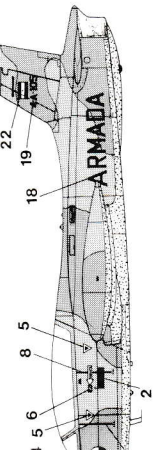
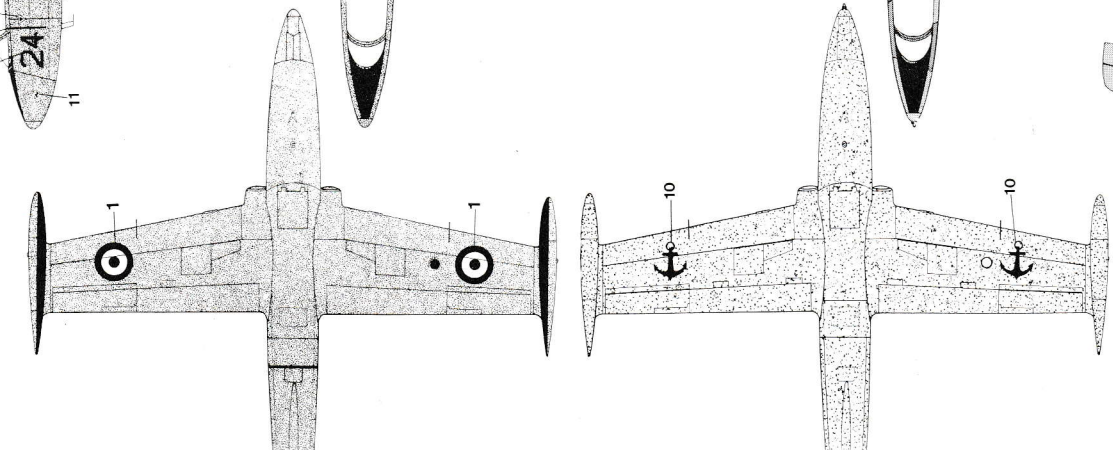

AERMACCHI, MB-326
 Central Flying School
 Royal Australian Air Force

©

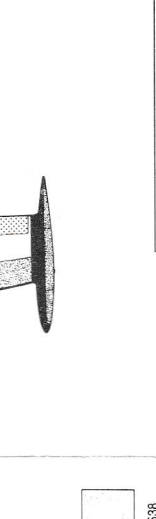
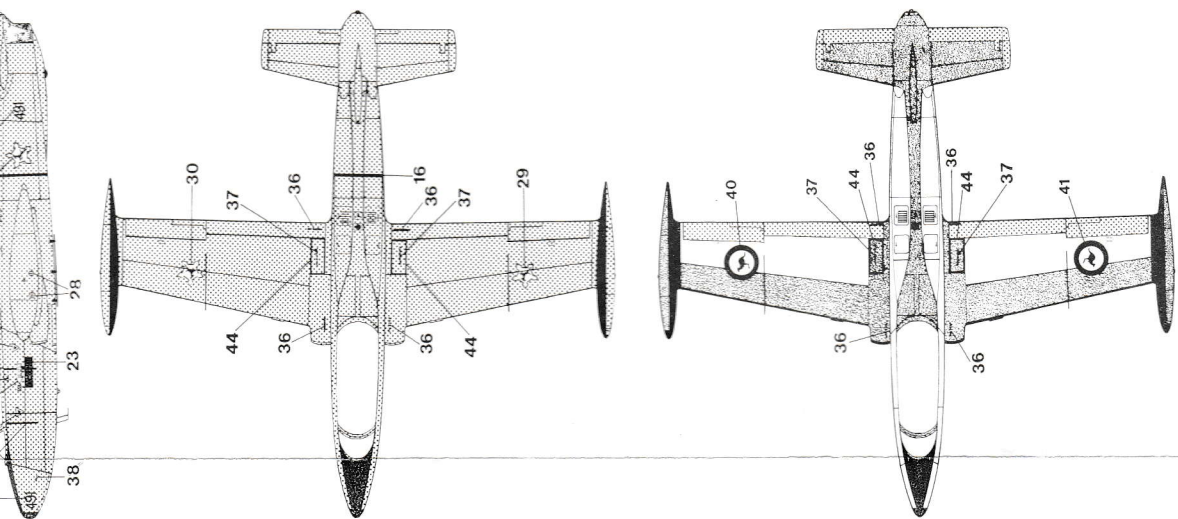

Aermacchi, MB-326
Scuola Volo Basico Iniziale
AMI, Italian Air Force

(A)

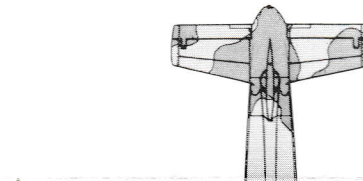
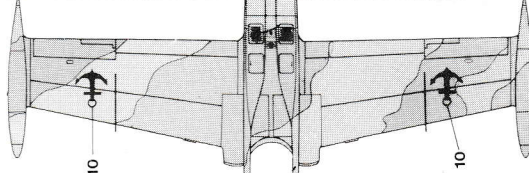
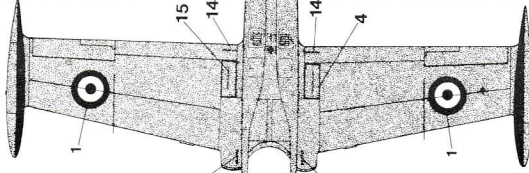
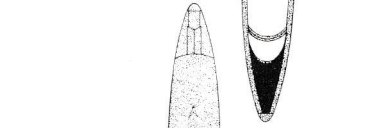
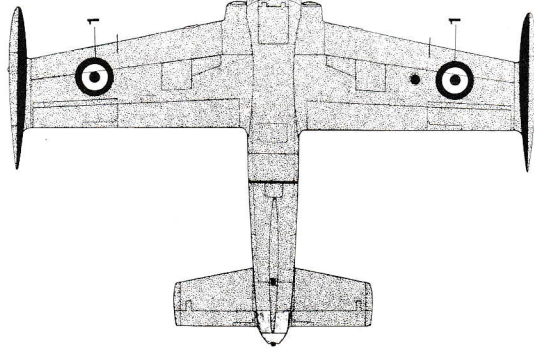
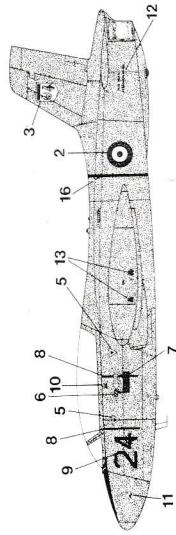

Aermacchi, MB-326 IMPALA MK I
n. 83° Squadron, SAAF

(C)

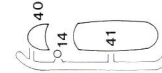
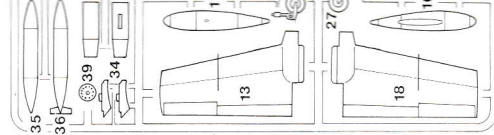
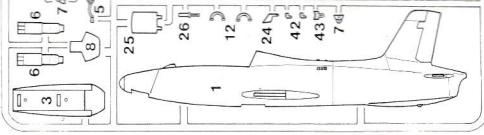
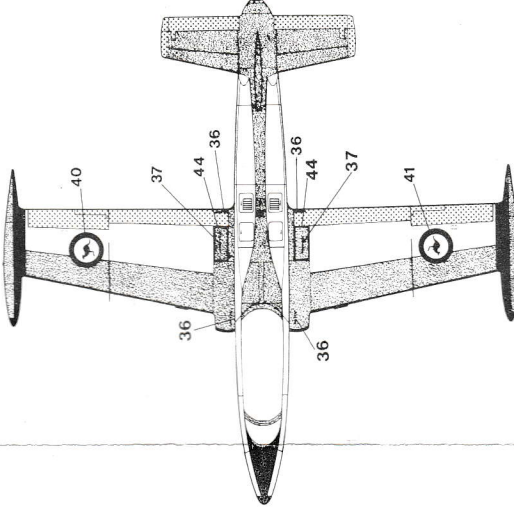
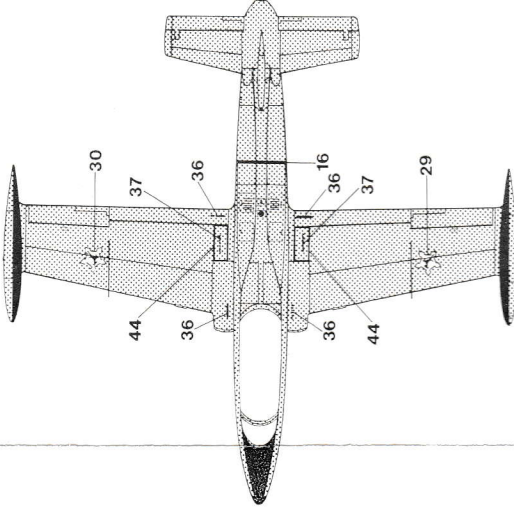
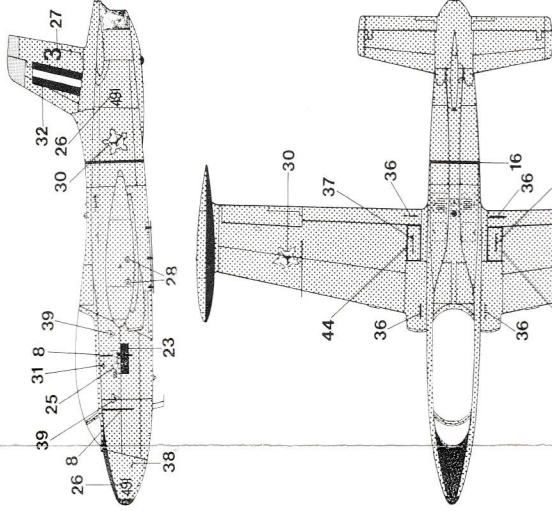
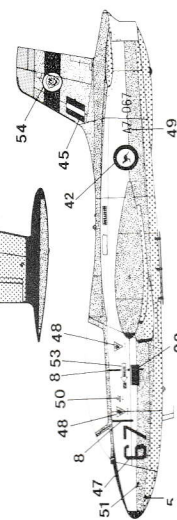
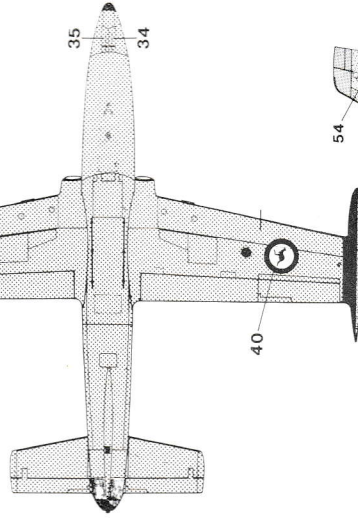
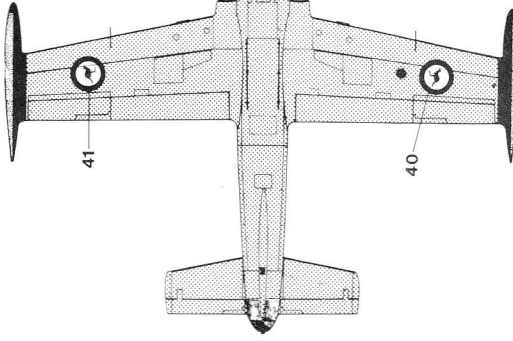
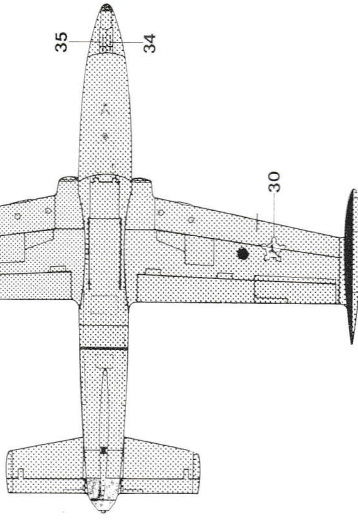
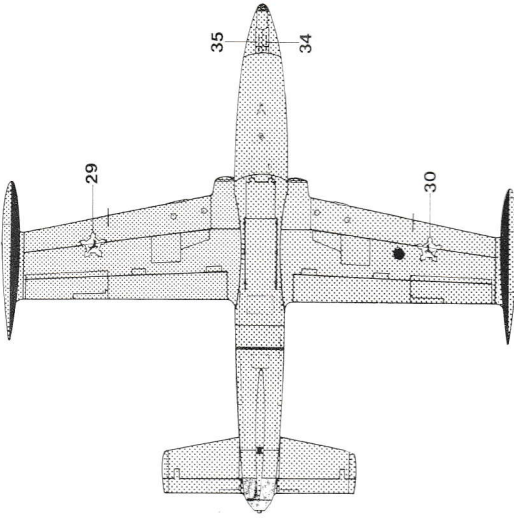

AERMACCHI, MB-326 GB, PELICANO
1° Escuadrilla de Ataque, Argentina

(B)

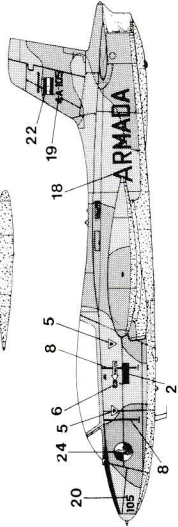

FS, 27038
Nero
Black
Noir
Schwarz

FS, 17875
Bianco
White
Blanc
Weiss

FS, 11246
Arancio
Orange
Orange
Orange

FS, 37778
Alluminio
Aluminium
Aluminium
Aluminium

FS, 30318
Marone
chiaro
Light brown
Brun clair
Hellbraun

FS, 34079
Verde scuro
Dark green
Vert foncé
Dunkelgrün

FS, 36473
Grigio
chiaro
Light grey
Gris clair
Hellgrau

FS, 36440
Grigio
chiaro
Light grey
Gris clair
Hellgrau

FS, 23538
Giallo
Yellow
Jaune
Gelb

AERMACCHI, MB-326
Central Flying School
Royal Australian Air Force

(D)

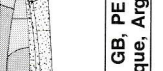
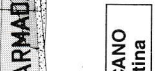
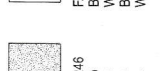
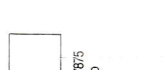

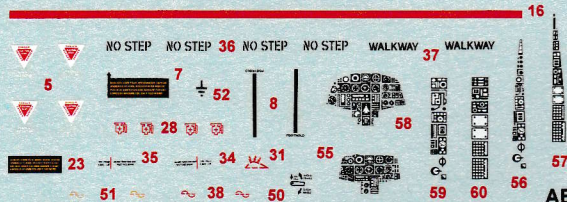
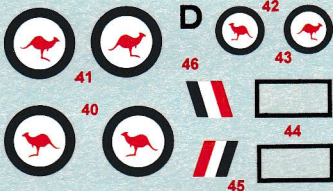
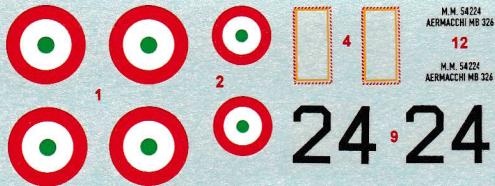

ART.011
AERMACCHI MB 326

A7-067
A7-067

