

## Sd.Kfz. 251/6 Ausf. A

### Германский командный бронетранспортер II MB

Основным бронетранспортером германского Вермахта стал полугусеничный Sd.Kfz.251, созданный фирмой «Ганомэг». Его использовали для транспортировки мотопехоты (Sd.Kfz.251/1). Бронетранспортеры состояли на вооружении немецкой армии в течение всей Второй мировой войны и применялись на всех театрах войны. Всего было выпущено 15252 машины.

Модификация Sd.Kfz.251 Ausf.A производилась в 1939-1940 г. Небольшое количество бронетранспортеров было выпущено в качестве машин радиосвязи Sd.Kfz.251/6 для высшего командования Вермахта.

#### Тактико-технические характеристики бронетранспортера Sd.Kfz.251/6 Ausf.A

Боевая масса, т.....	9,14
Экипаж, чел.....	2+3
Длина, мм.....	5830
Ширина, мм.....	2550
Высота, мм.....	1750
Двигатель.....	Maybach HL 42 TURKM, 100 л.с.
Максимальная скорость, км/ч.....	53
Запас хода, км.....	300
Бронирование, мм.....	8-14,5
Вооружение.....	1x7,92-мм пулемет MG 34

#### ВНИМАНИЕ!

Перед сборкой внимательно прочитайте руководство по монтажу. Каждая деталь пронумерована. Соблюдать последовательность монтажа. Необходимые рабочие инструменты: нож и напильник для зачистки деталей, резиновая лента, клейкая лента и зажимы для сушки белия для приклеивания олеофобных деталей. Детали из пластика очистить в растворе мягкого моющего средства и высушить на воздухе для того, чтобы краска и переводные картинки лучше прилипали. Перед приклеиванием проверить, подходят ли детали, клей наносить экономно. Хром и краску удалить с поверхностей олеофобия. Небольшие детали покрасить перед тем, как они будут удалены из рамок. Краску необходимо хорошо просушить, только после этого продолжать сборку. Каждую соответствующую переводную картинку отдельно вырезать и примерно на 20 секунд окунуть в теплую воду. На обозначенном месте картинку отделить от бумаги и прижать промокающей бумагой.

#### ИСПОЛЬЗУЕМЫЕ КРАСКИ / USED COLORS:

	Revell	Tamiya		
<b>A</b>	302	X18	Черный, полуматовый	Semigloss Black
<b>B</b>	178	XF63	Темно-серый, матовый	Tank Grey
<b>C</b>	105	XF2	Белый, матовый	Flat White
<b>D</b>	189	XF78	Дерево	Wood
<b>E</b>	381	X9	Коричневый, полумат.	Brown
<b>F</b>	191	X32	Сталь Steel	Steel

## Sd.Kfz. 251/6 Ausf. A

### WWII German Armoured Command Vehicle

The main armoured personnel carrier of the German Wehrmacht was the half-track Sd.Kfz.251, created by the firm "Hanomag". It was used to transport motorized infantry (Sd.Kfz.251/1). The armoured personnel carriers were in service with the German army throughout the Second World War and were used in all theaters of war. A total of 15252 vehicles were produced.

Modification Sd.Kfz.251 Ausf.A was produced in 1939-1940. Some armoured personnel carriers were issued as Sd.Kfz.251/6 command vehicles for the High Command of the Wehrmacht.

#### Tactical and Technical Specifications of Sd.Kfz.251/6 Ausf.A

Combat weight, kg.....	9,14
Crew, men.....	2+3
Length, mm.....	5830
Width, mm.....	2550
Height, mm.....	1750
Engine.....	Maybach HL 42 TURKM, 100 hp
Max. Speed, km/h.....	53
Range, kmq.....	300
Armour, mm.....	8-14,5
Armament.....	1x7,92 mm MG 34

#### CAUTION!

Read the instructions thoroughly prior to assembly. Each component is numbered. Adhere to specified sequence of assembly. Tools required: knife and file for removal of components from frame; rubber bond, adhesive tape and clothes pegs for clamping components together after applying adhesive. Clean plastic components in a mild detergent solution and allow to air-dry so that paint and transfers adhere better. Prior to applying adhesive, check to see whether the components fit together; apply adhesive sparingly. Remove chrome and paint from the contact surfaces. Paint small components before removing them from the frame. Allow paint to dry well, and only then continue to assemble. Cut out each transfer individually and immerse in warm water for approx. 20 seconds. Slide transfer off paper and into designated position, then press on with blotting paper.

	Revell	Tamiya		
<b>G</b>	109	X10	Темная сталь	Gunmetal
<b>H</b>	190	X11	Серебристый	Chrome Silver
<b>J</b>	183	XF64	Ржавчина	Rust
<b>K</b>	167	XF22	Серо-зеленый, матовый	Feldgrau
<b>L</b>	131	X7	Красный, глянцевый	Red

**01** СТАДИЯ СБОРКИ  
ASSEMBLY STEP

**?** ПРОИЗВОЛЬНЫЙ ВЫБОР  
OPTIONAL

**✂** ОТРЕЗАТЬ  
CUT OFF

**x2** СДЕЛАТЬ ДВЕ ДЕТАЛИ  
MAKE 2 PCS

**03** СБОРОЧНАЯ ЕДИНИЦА  
ASSEMBLY UNIT

**🔧** ПРОСВЕРЛИТЬ  
OPEN HOLE

**🚫** ПРИ СБОРКЕ НЕ ИСПОЛЬЗУЕТСЯ  
PARTS NOT FOR USE

**A** ИСПОЛЬЗУЕМАЯ КРАСКА  
USED COLOR



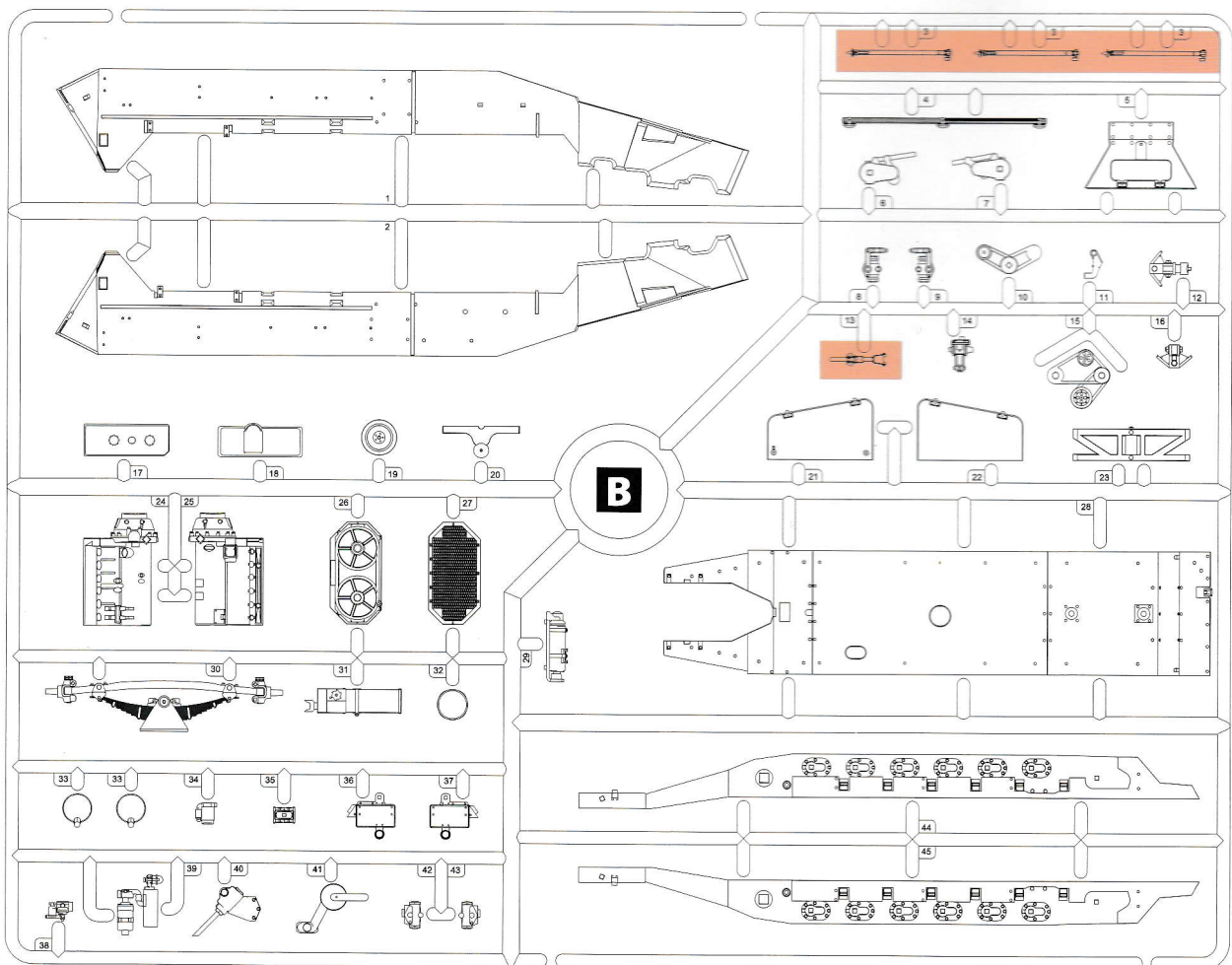
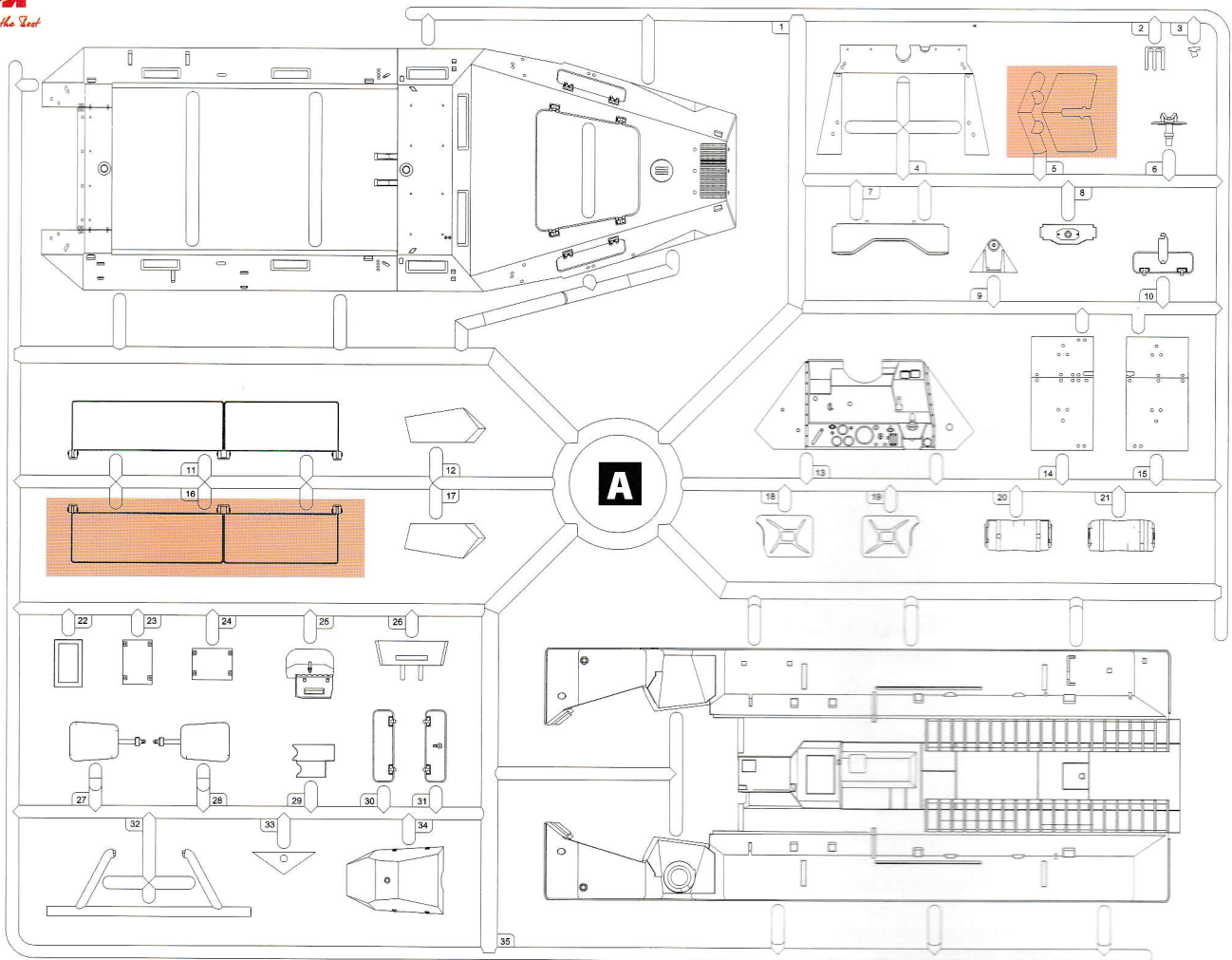

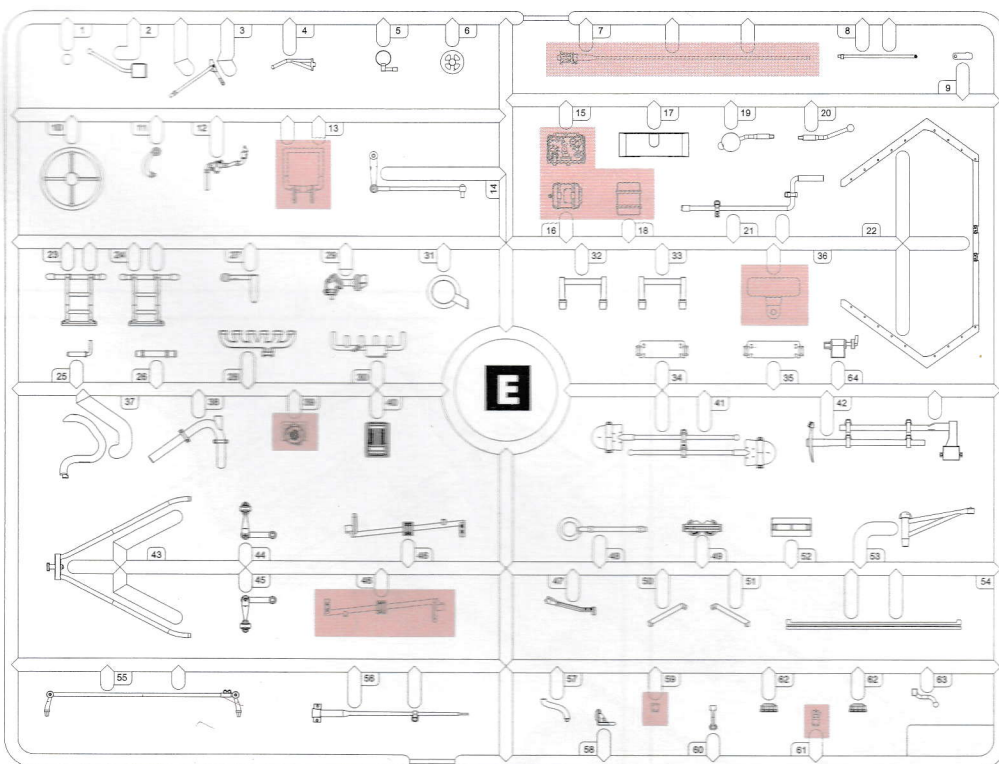
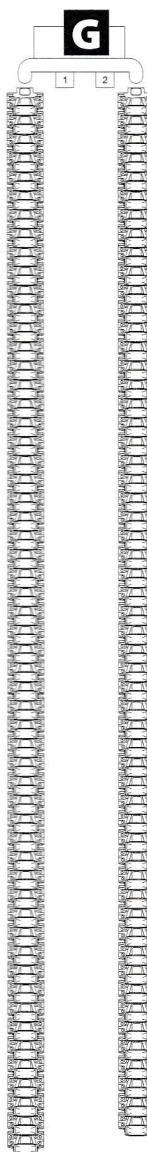
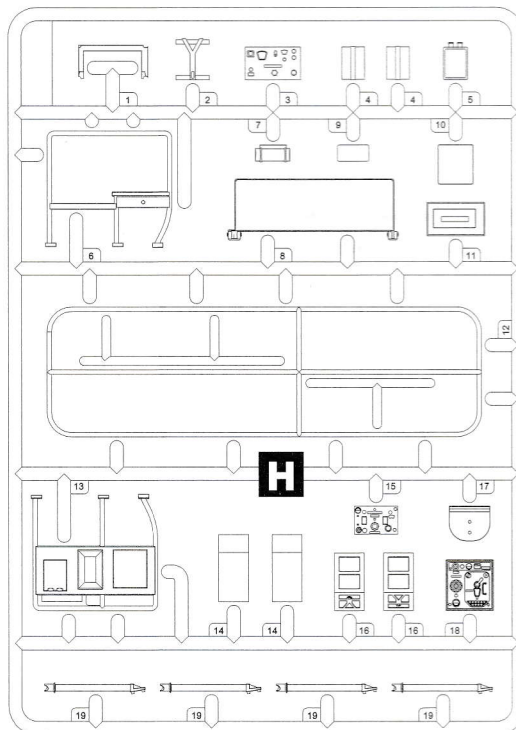
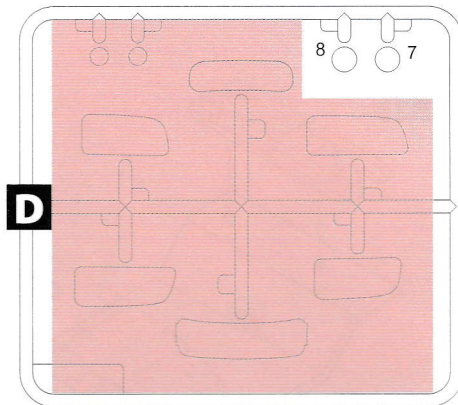
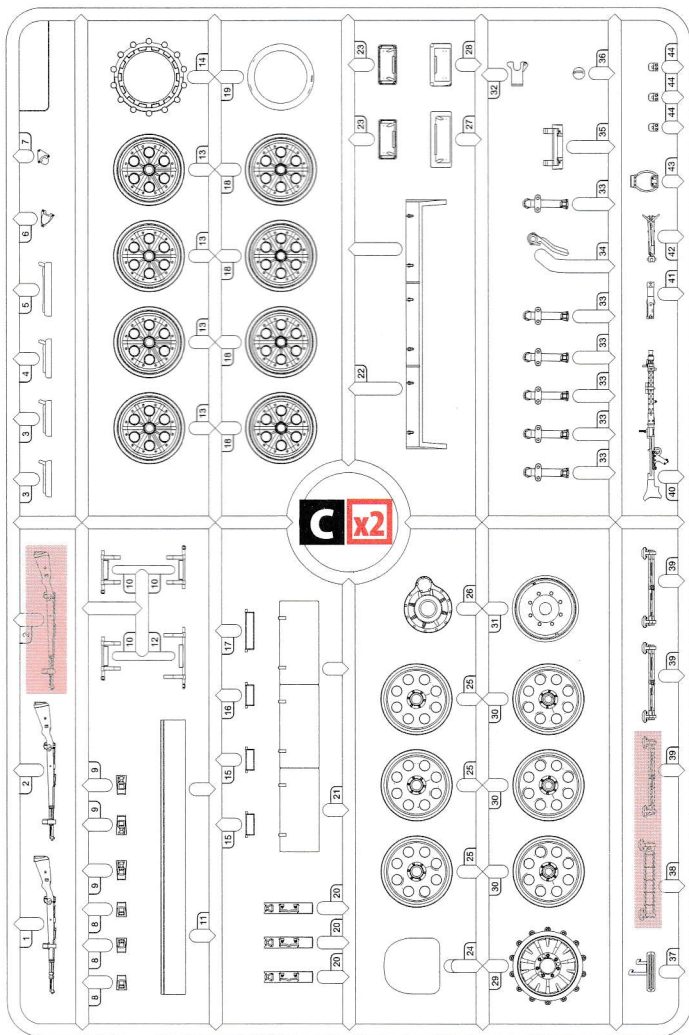



**01**

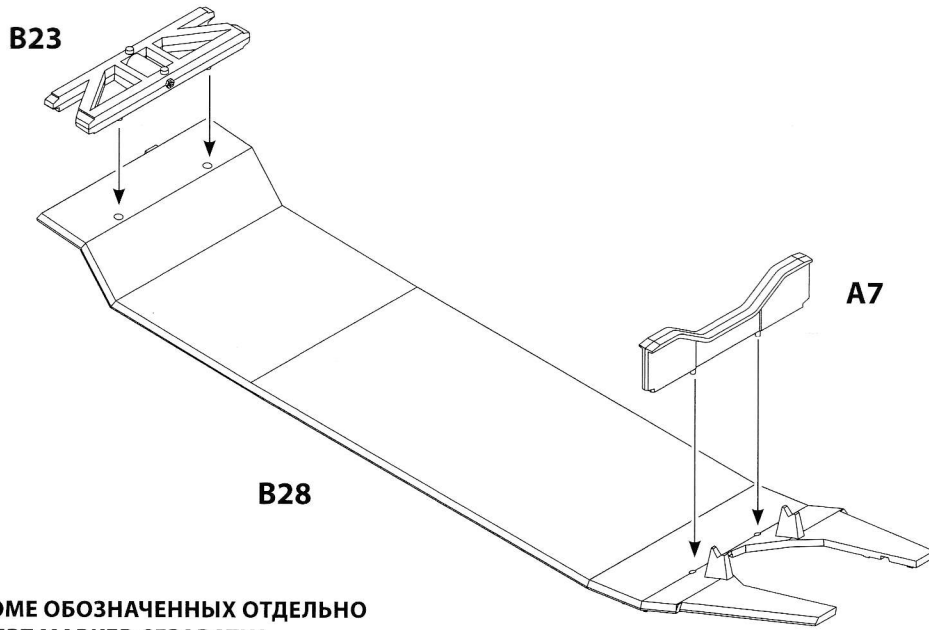

**B** ВСЕ ДЕТАЛИ, КРОМЕ ОБОЗНАЧЕННЫХ ОТДЕЛЬНО  
 ALL DETAILS EXCEPT MARKED SEPARATLY

**02**

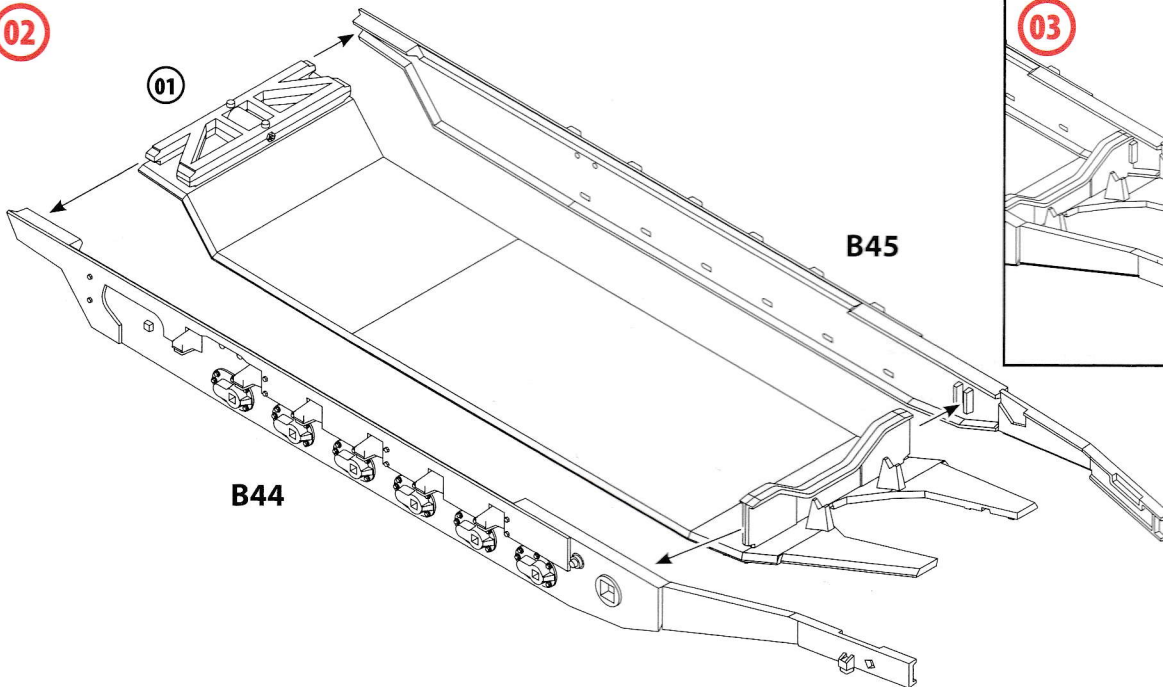

**03**

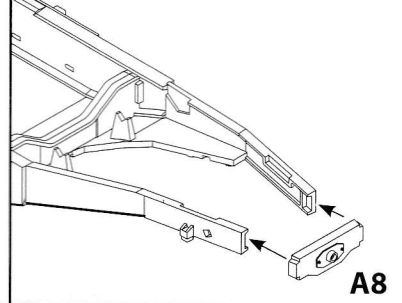

**04**

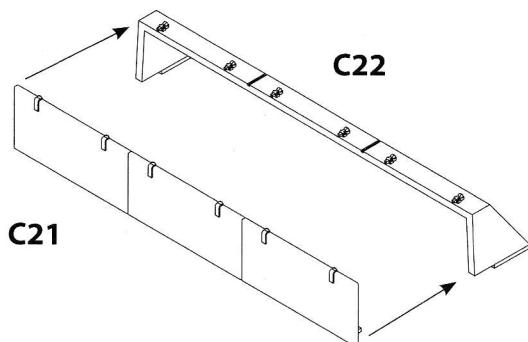

**05**

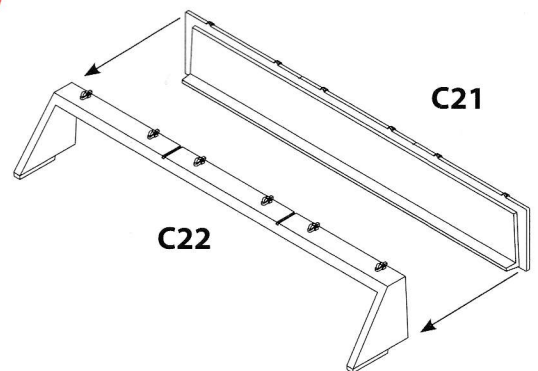



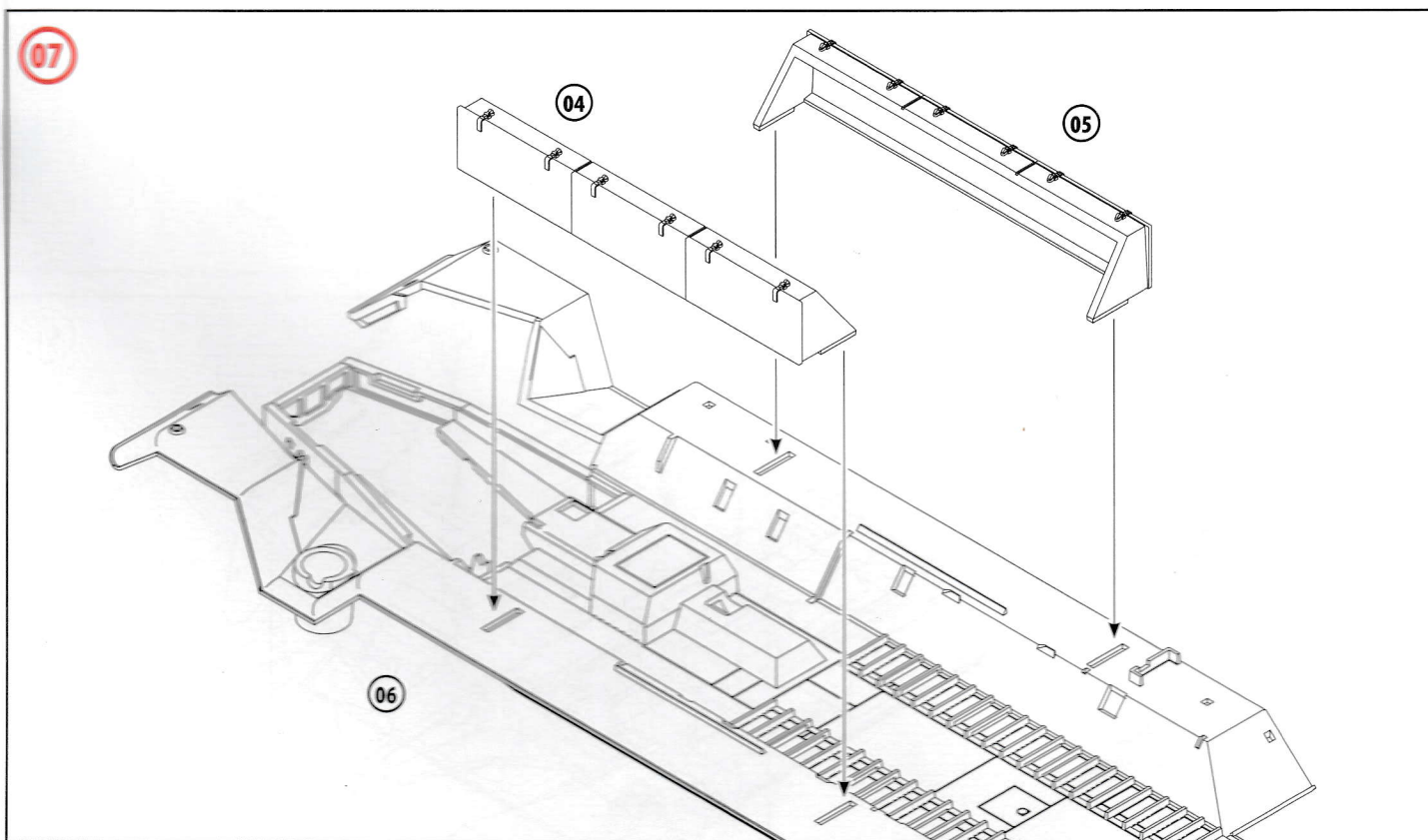
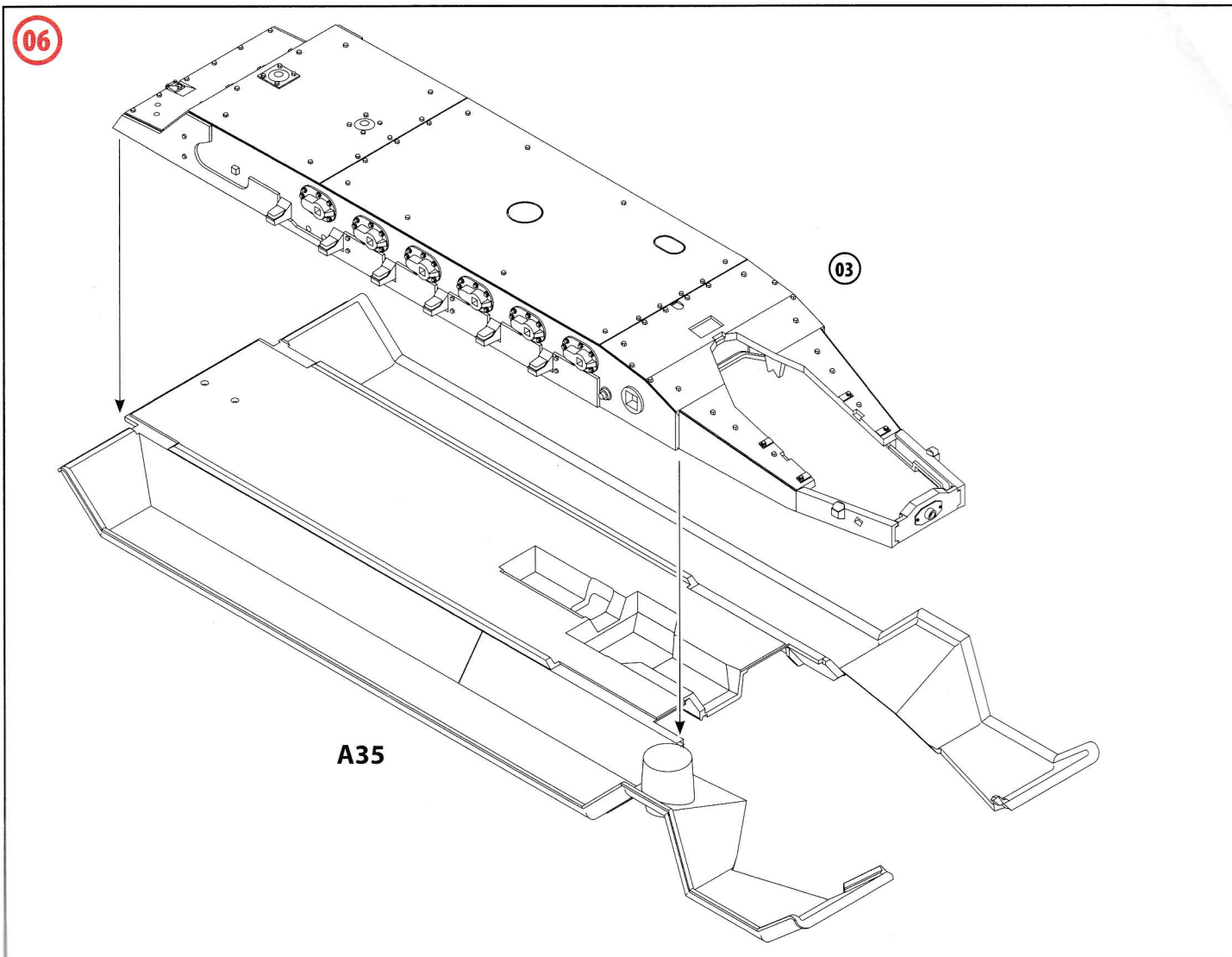

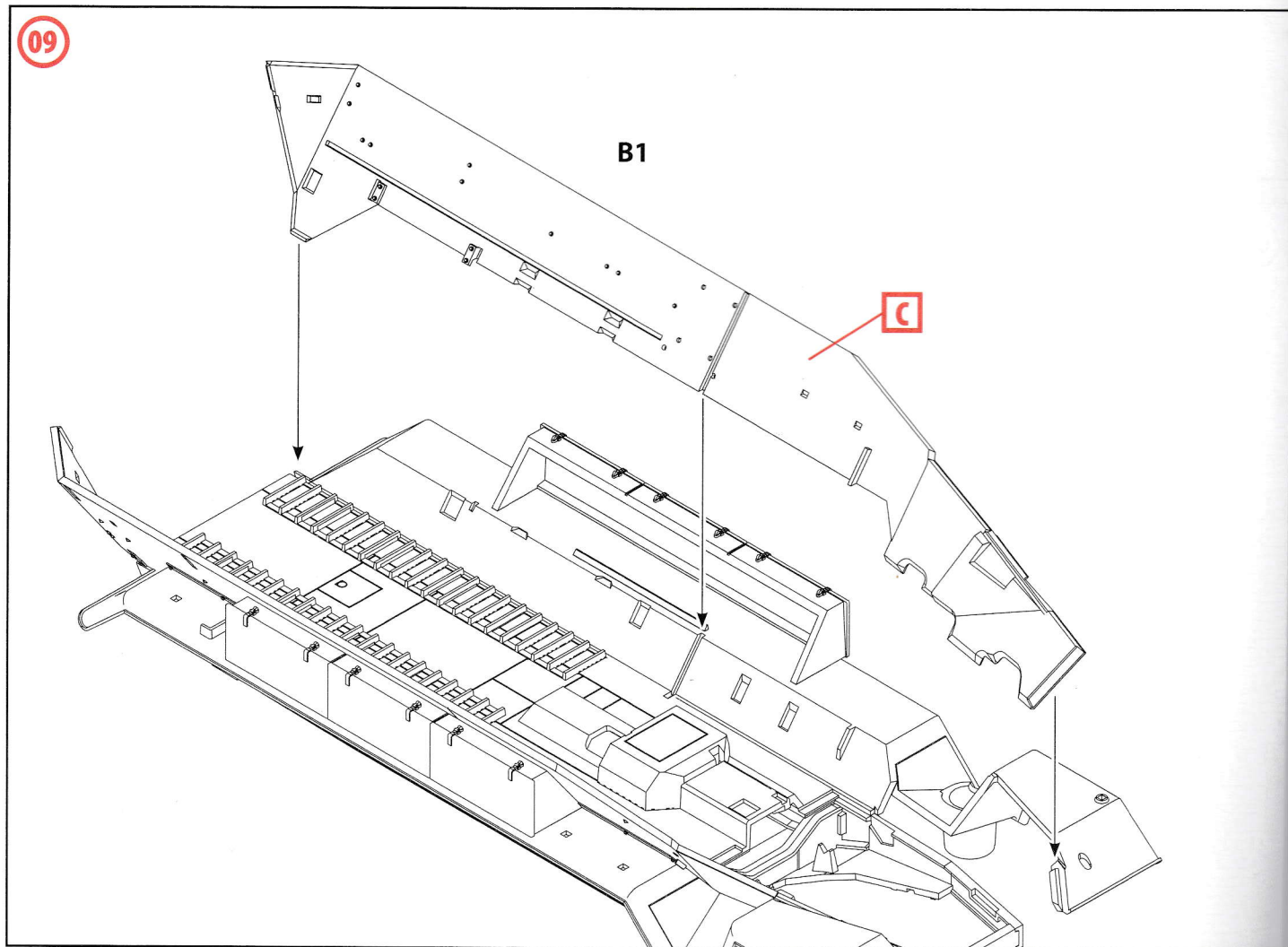
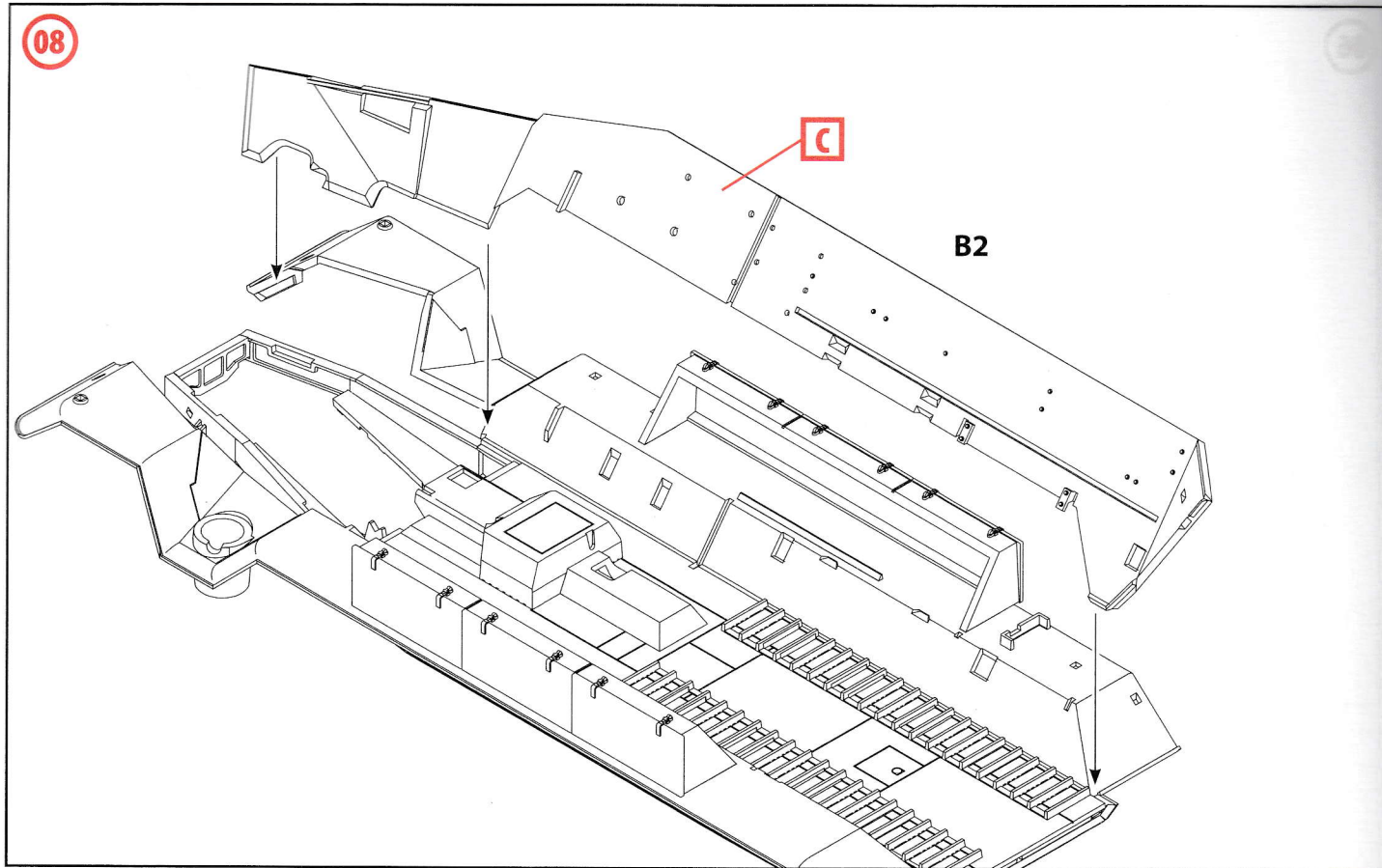



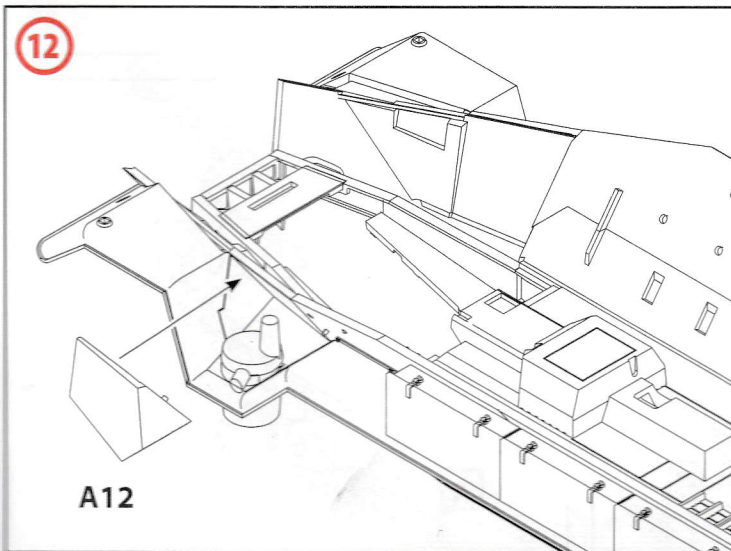
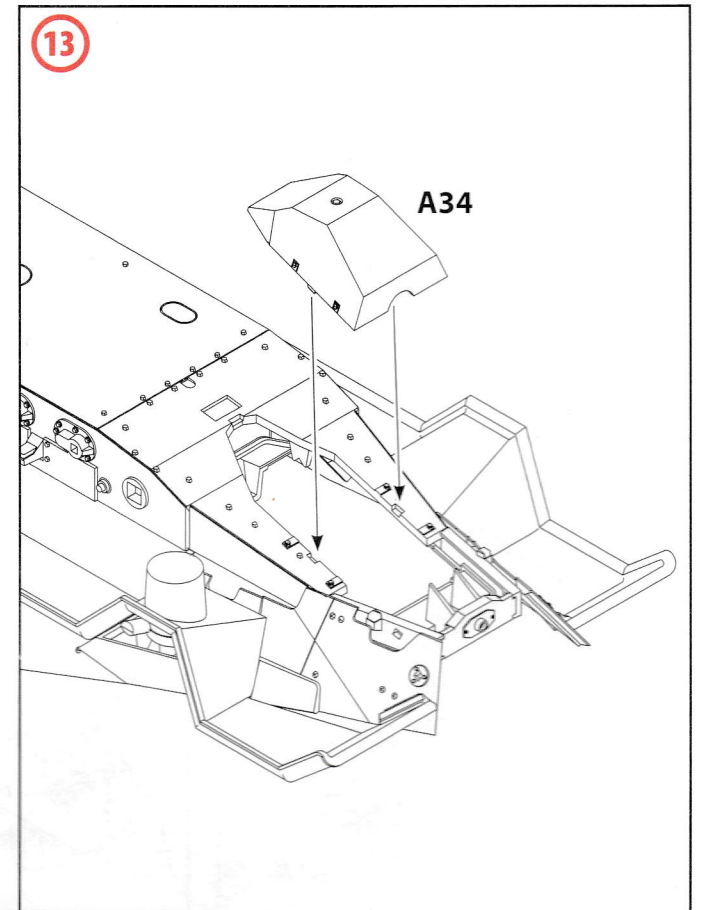
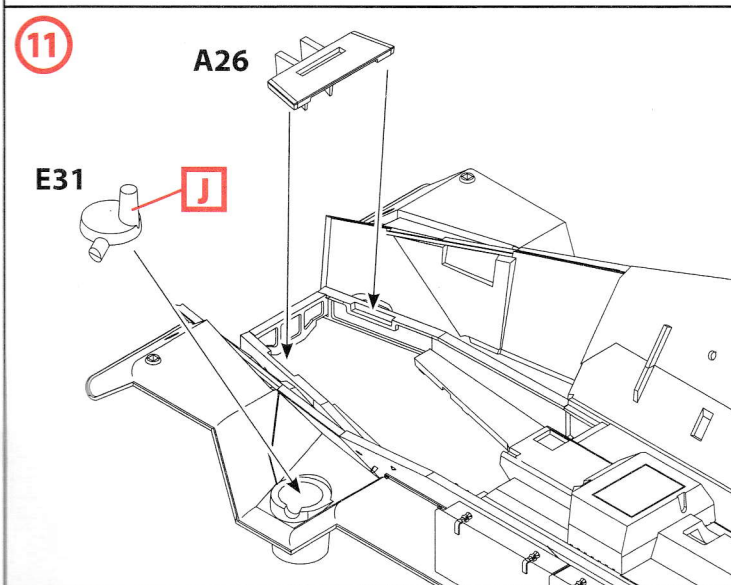
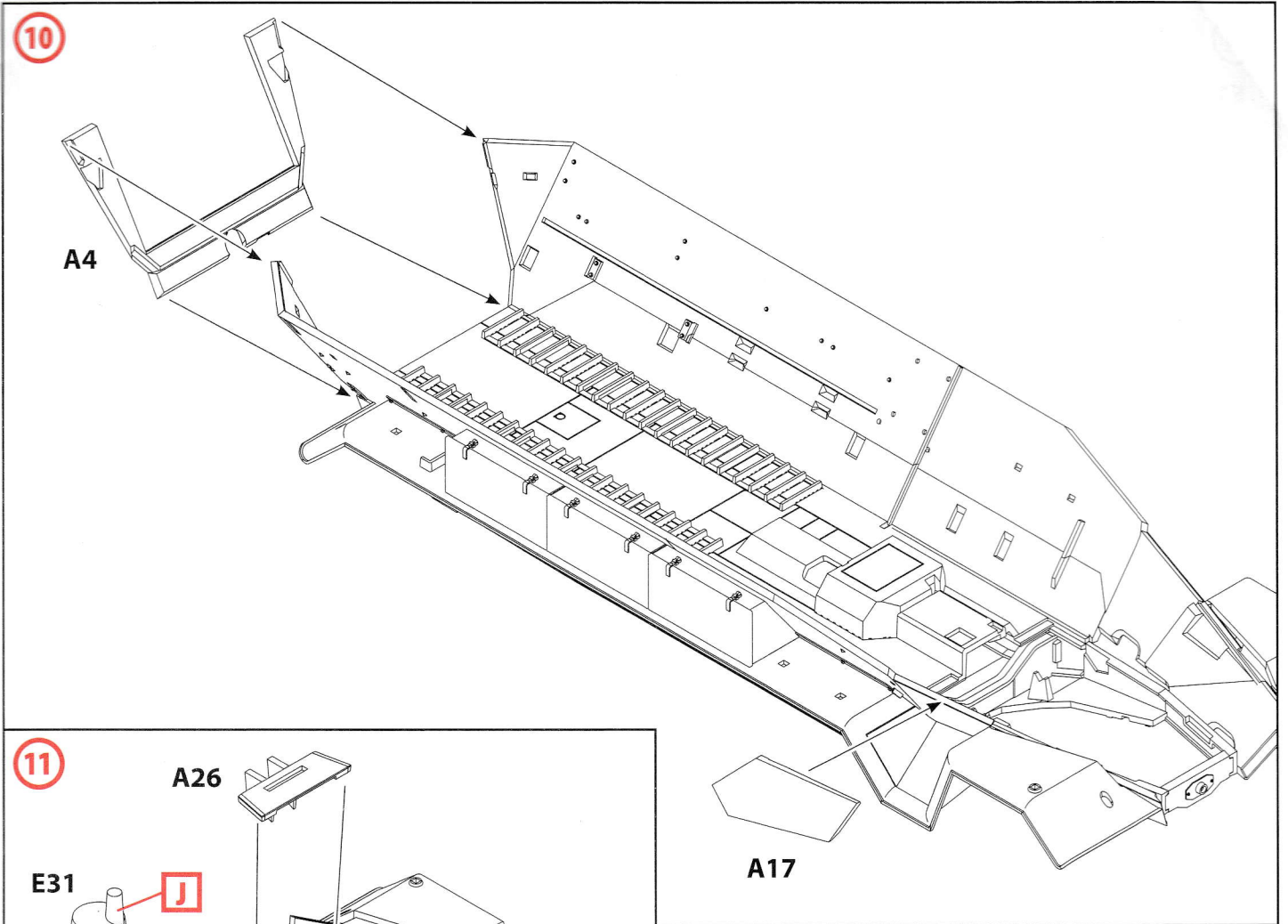

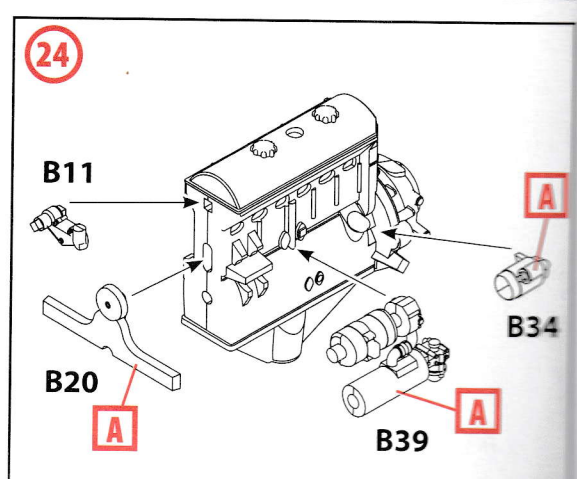
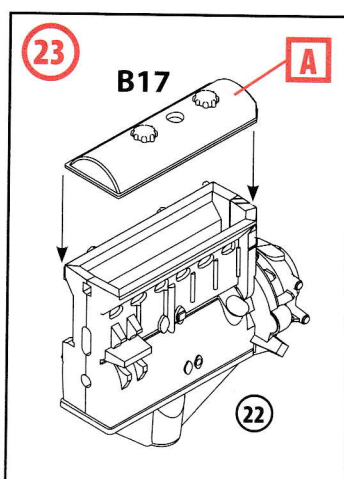
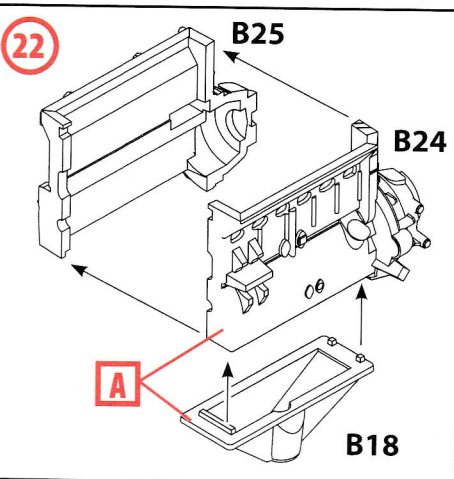
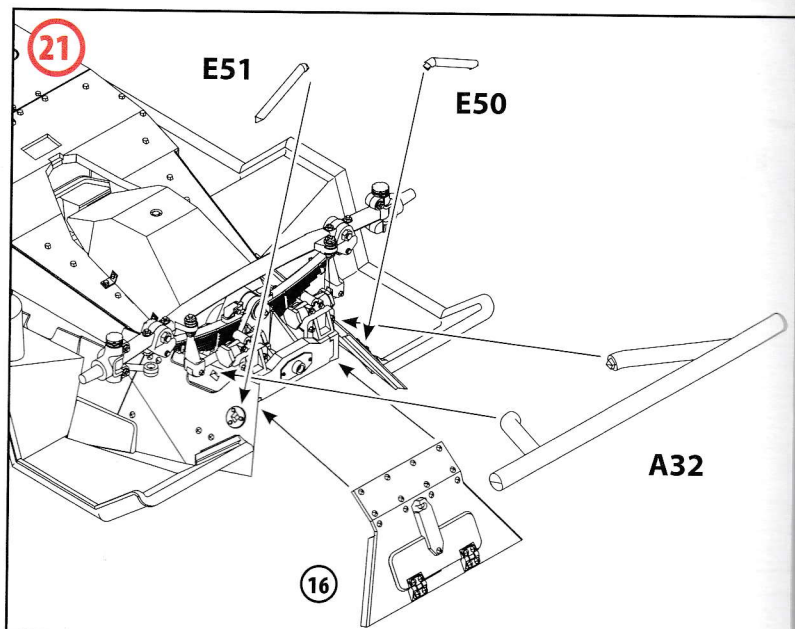
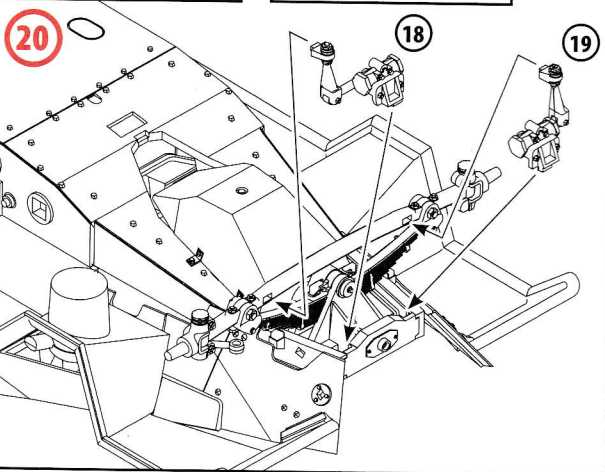
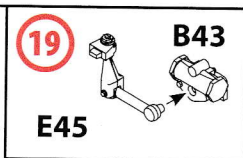
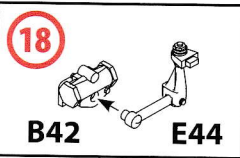
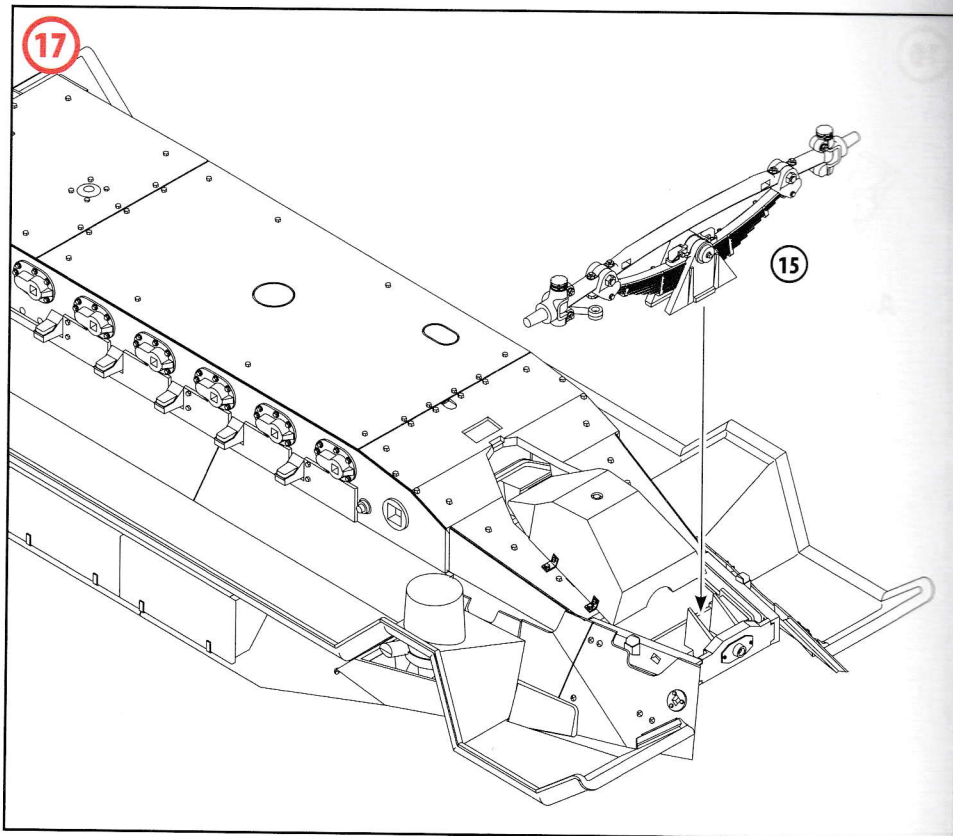
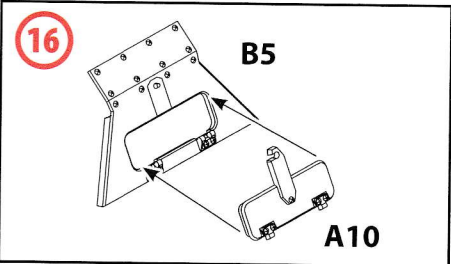
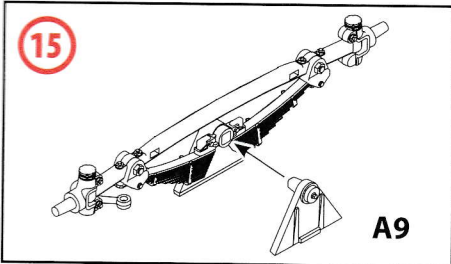
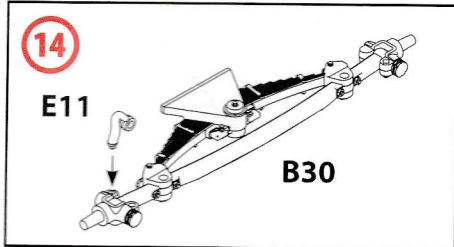



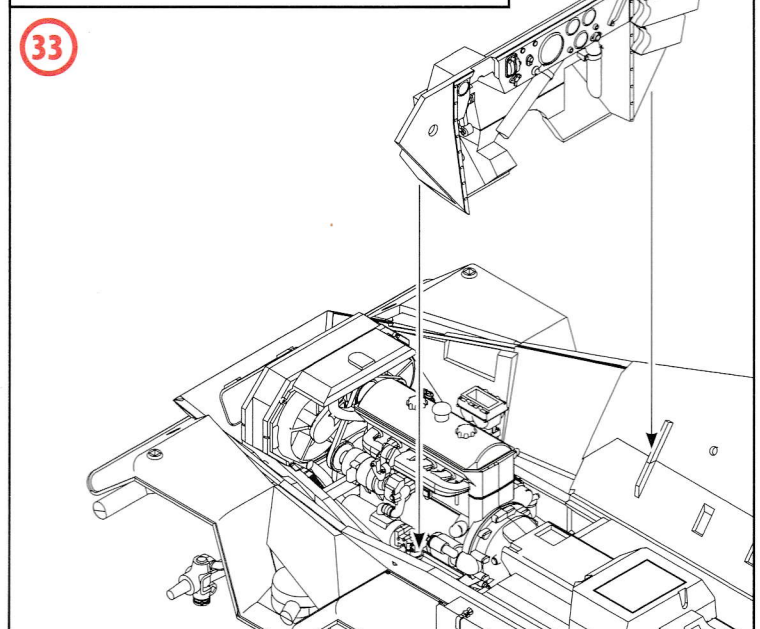
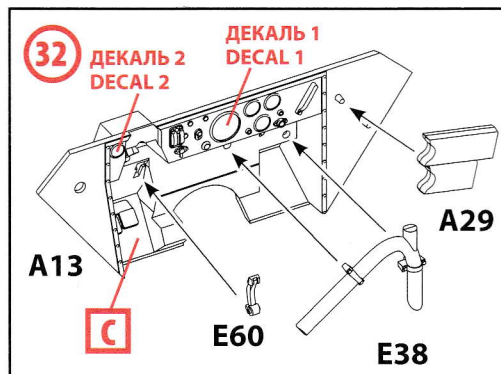
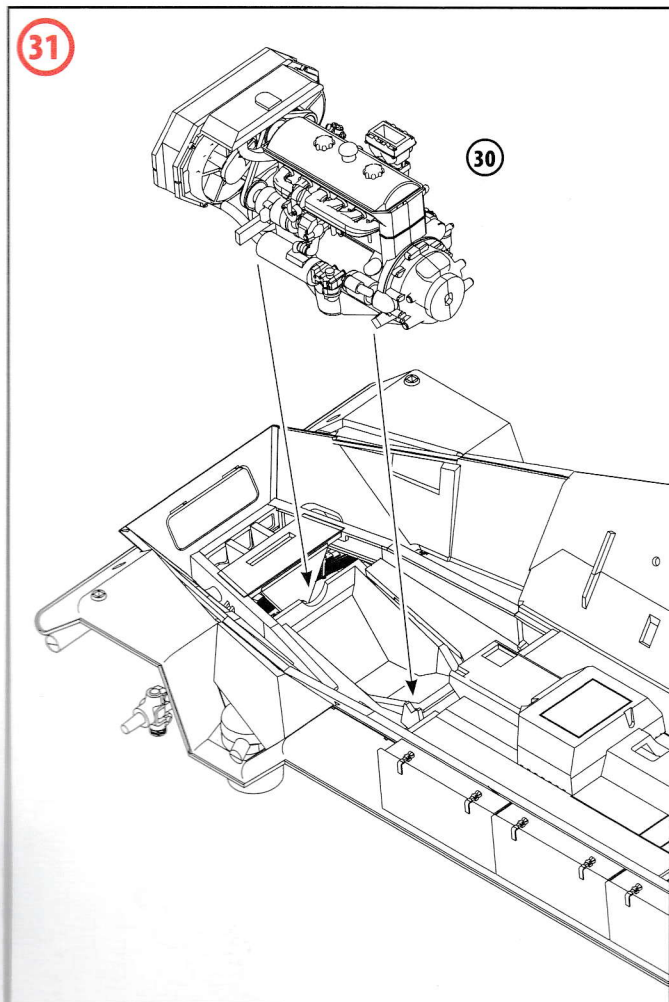
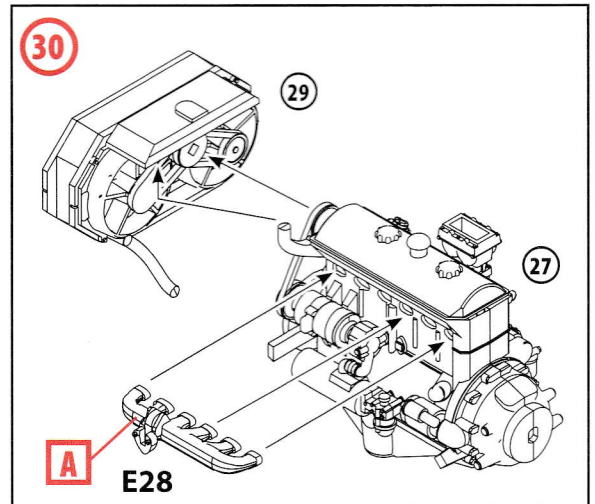
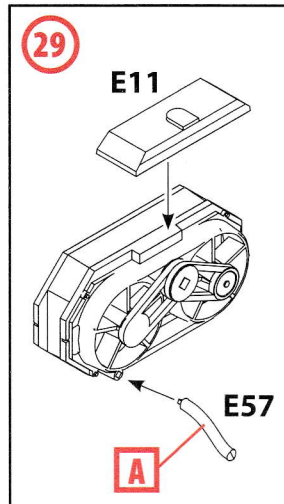
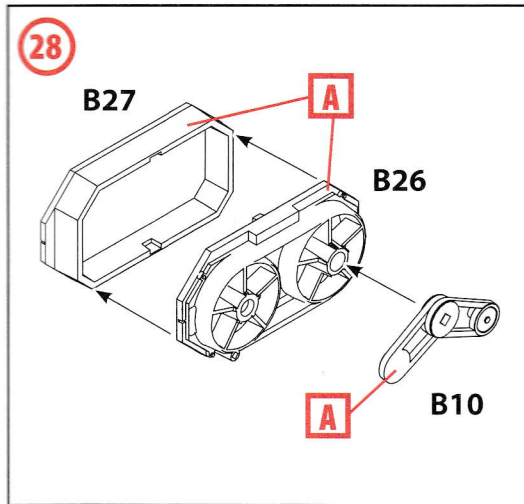
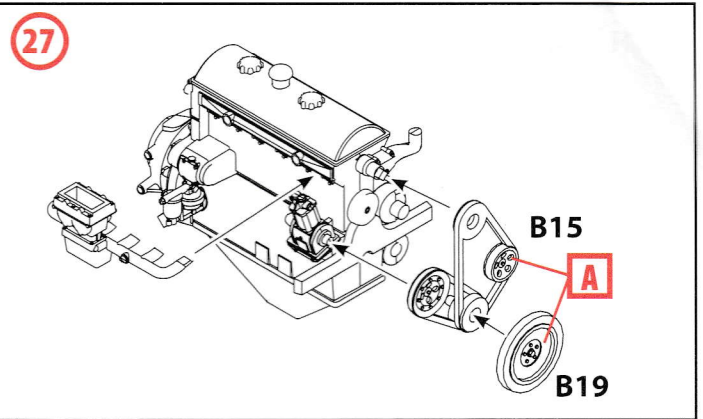
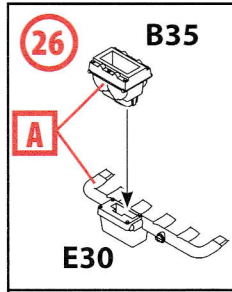
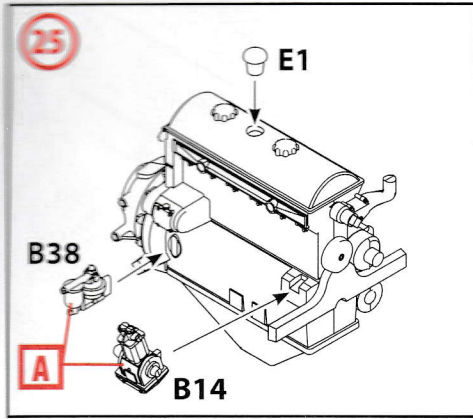

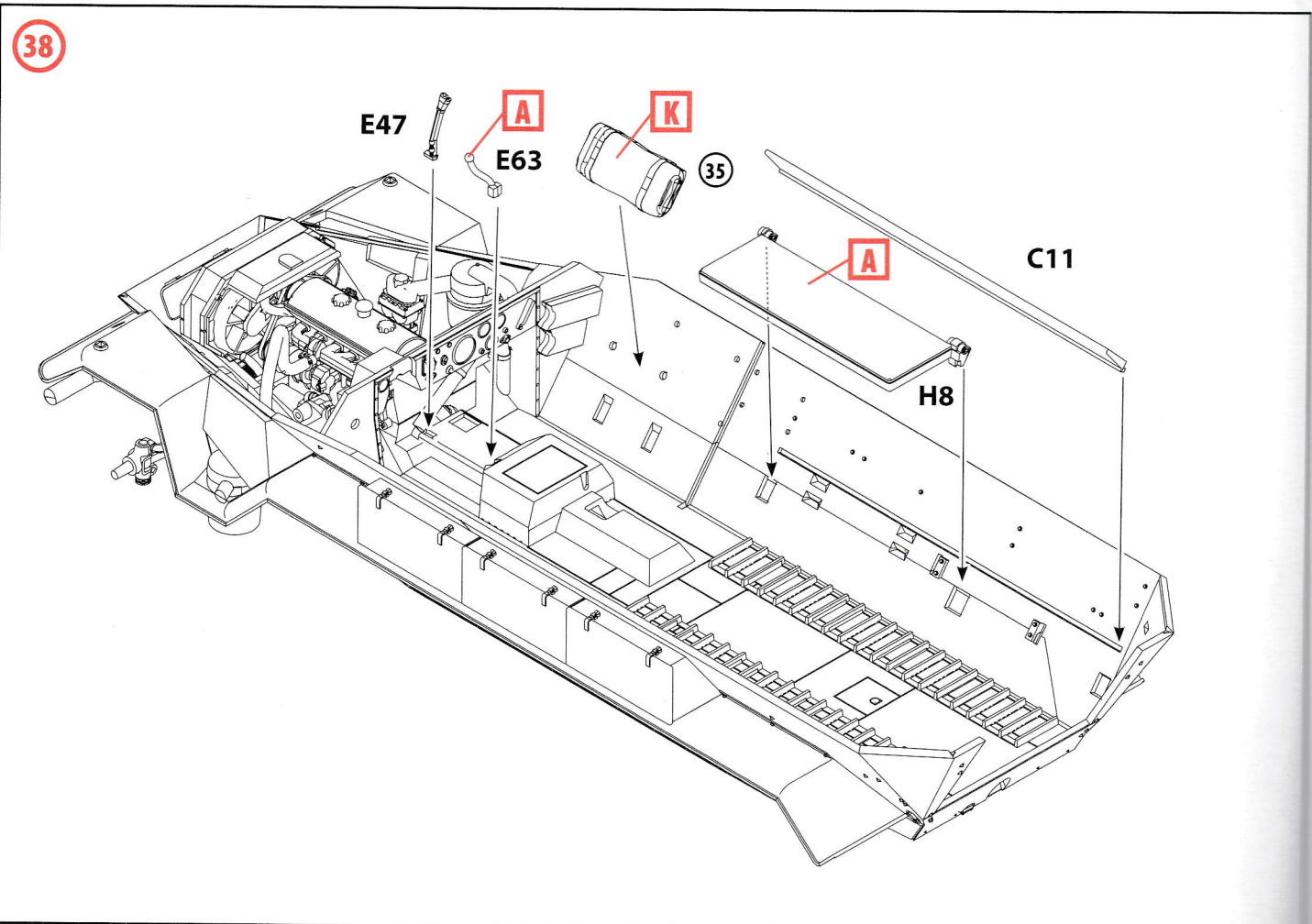
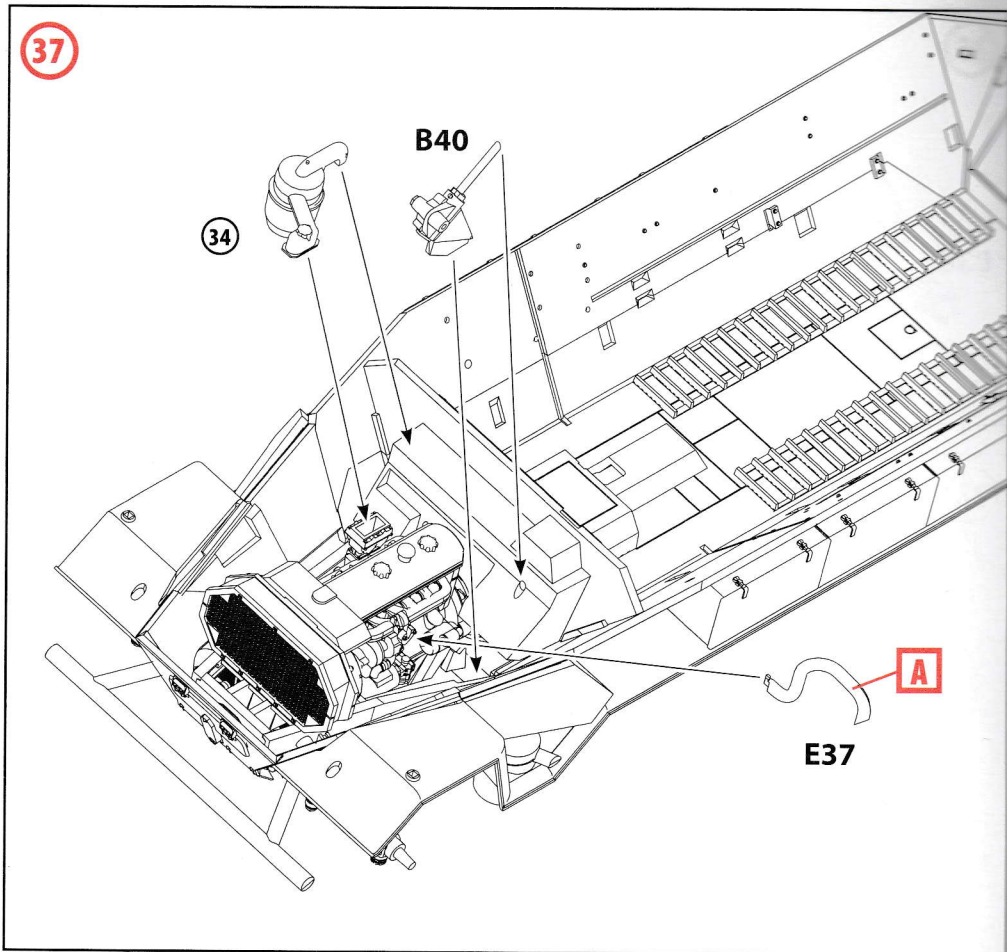
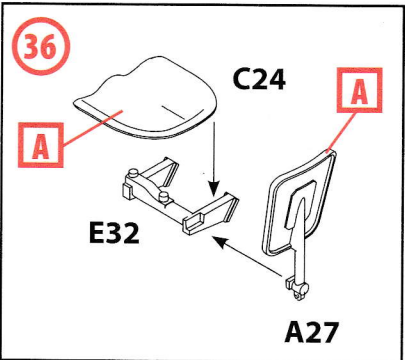
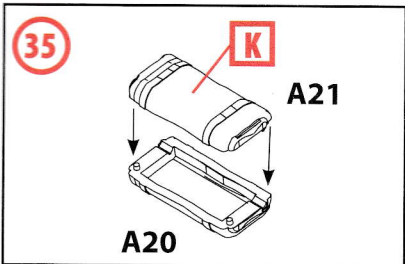
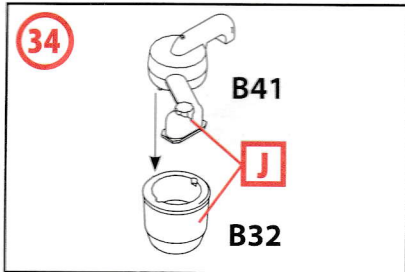



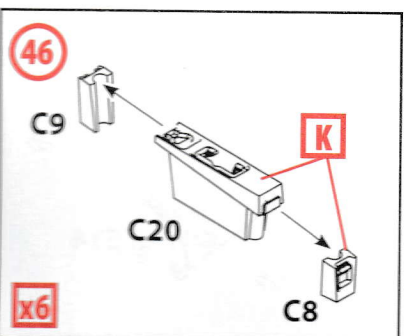
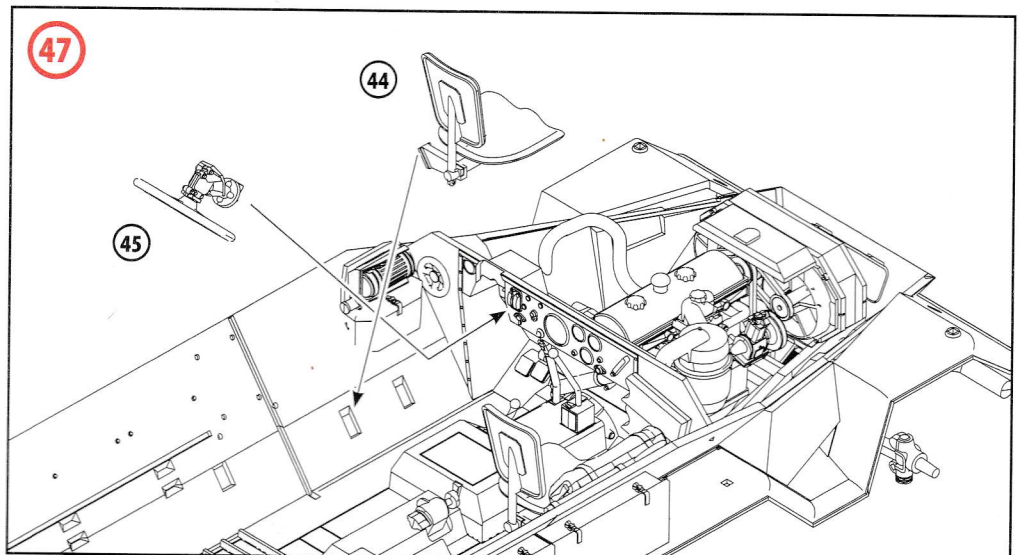
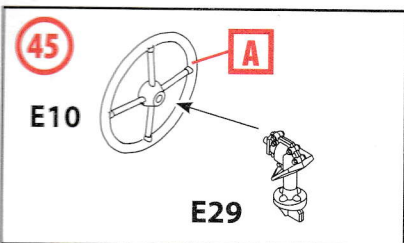
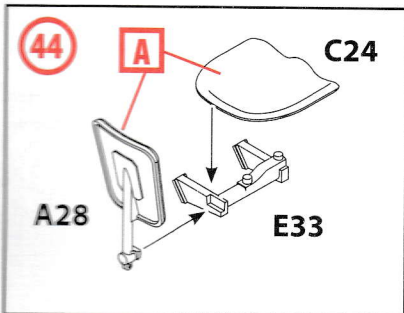
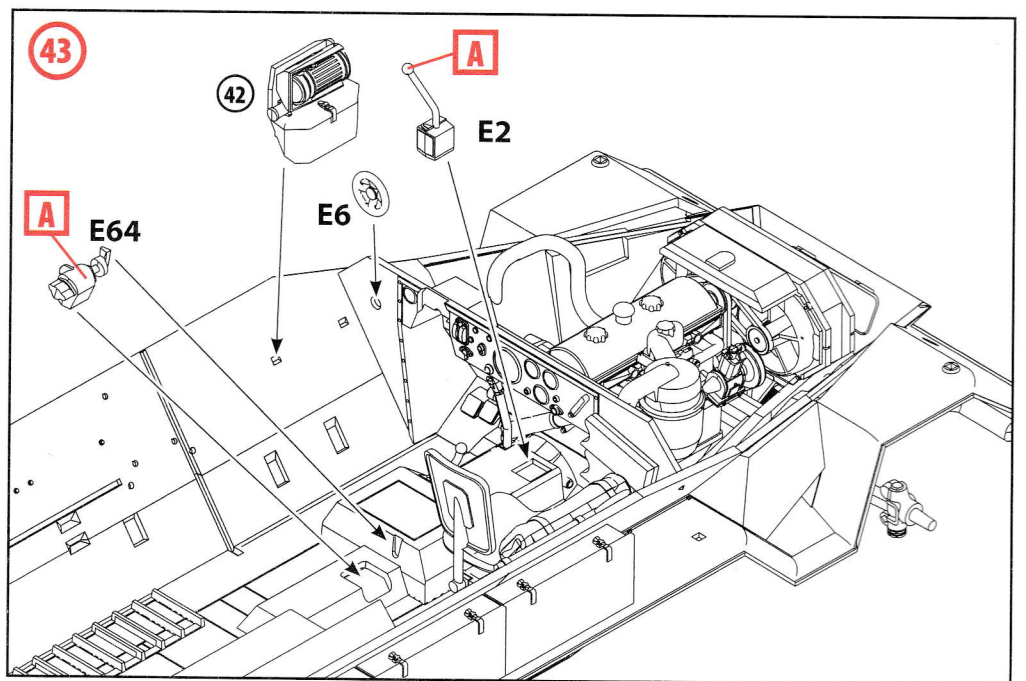
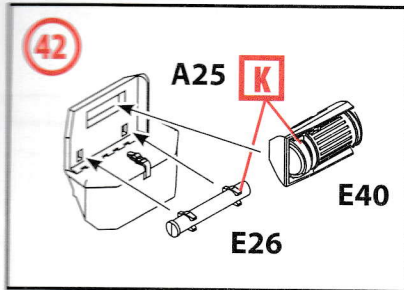
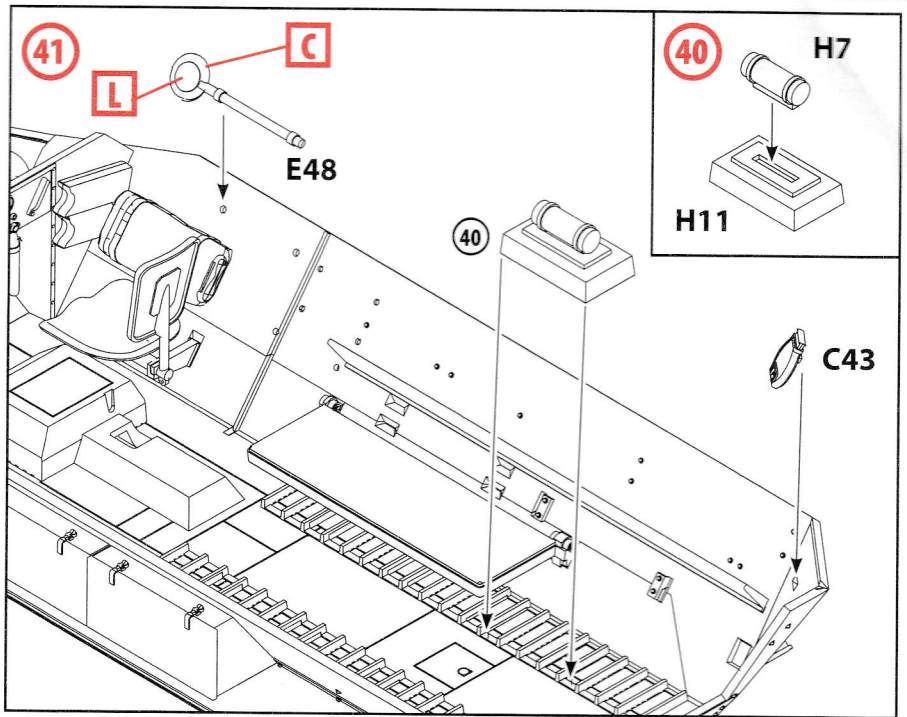
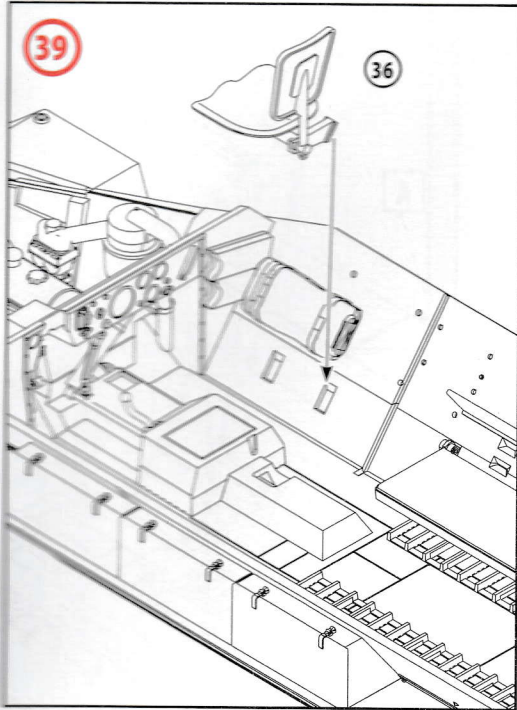



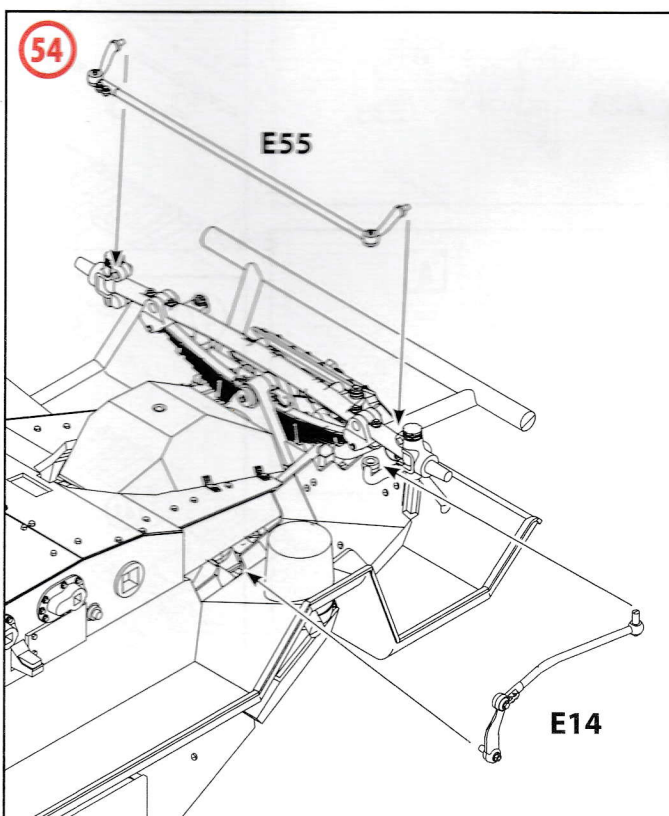
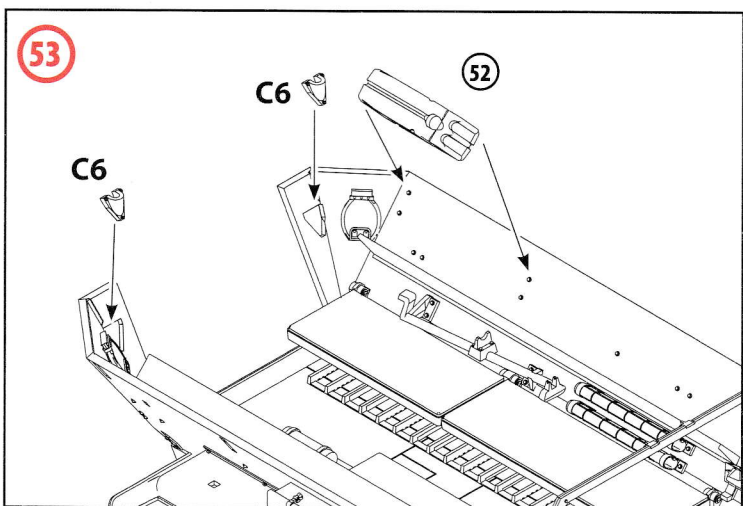
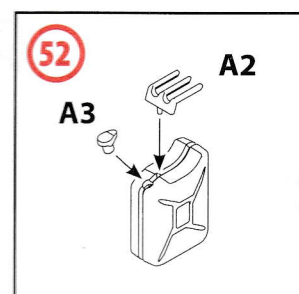
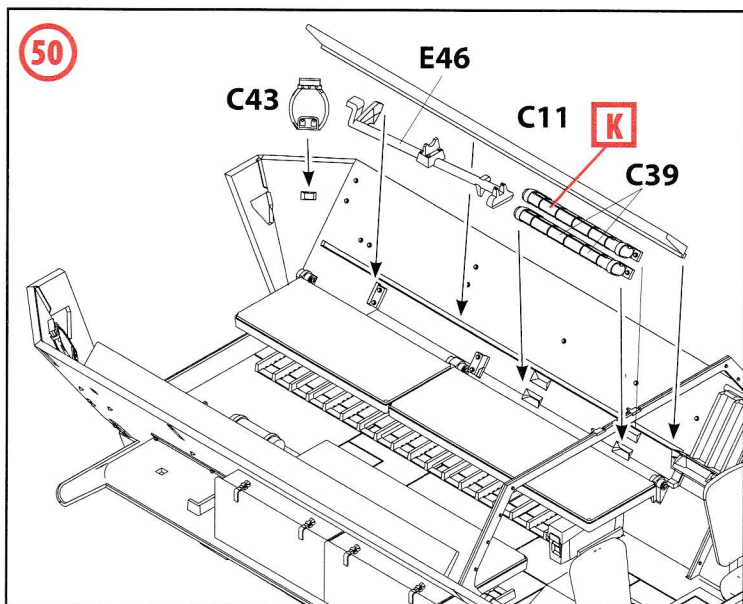
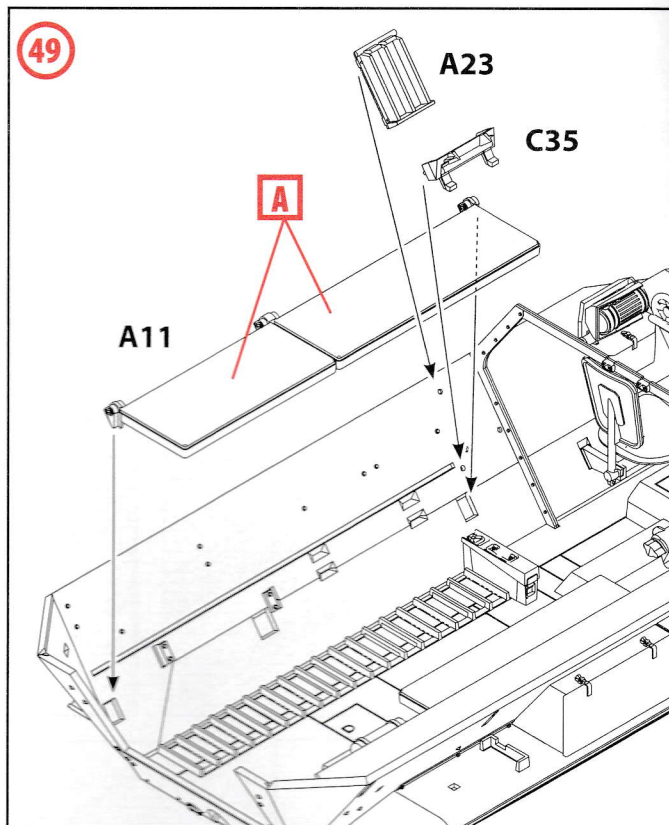
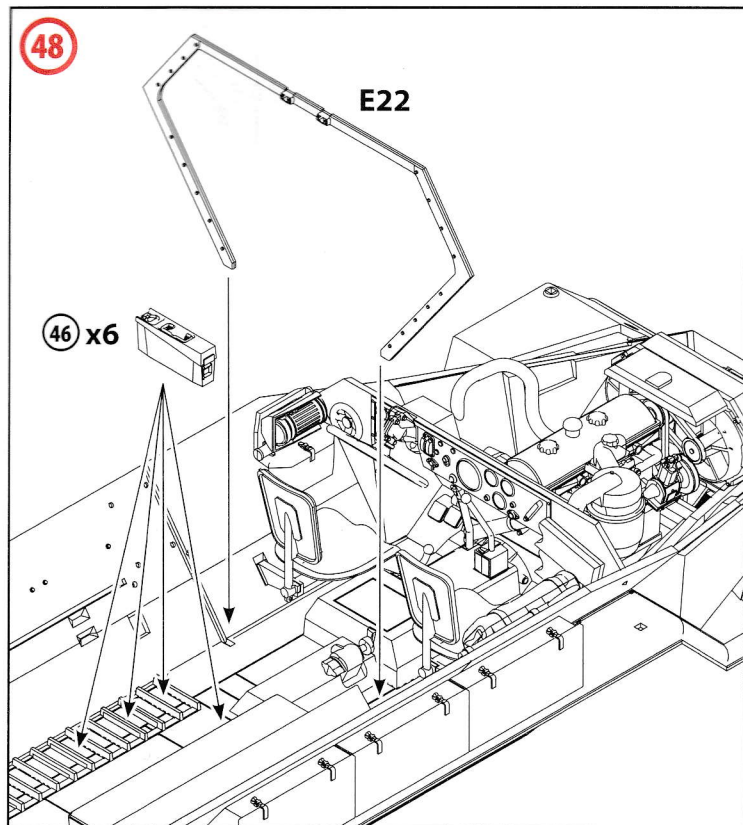



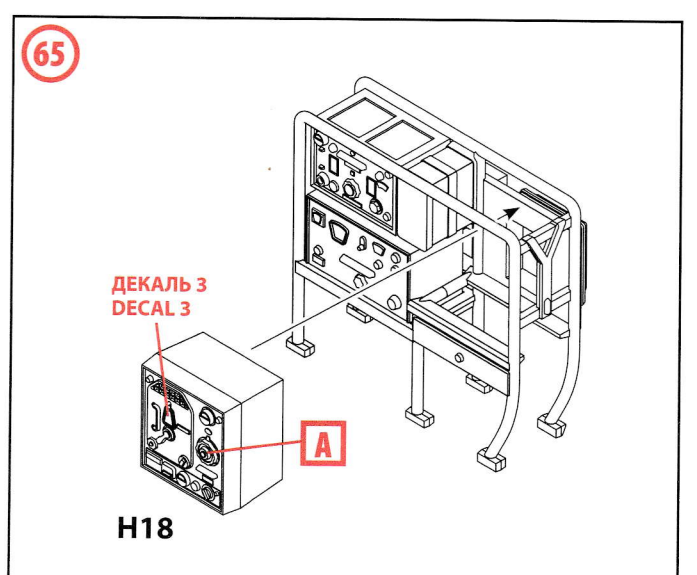
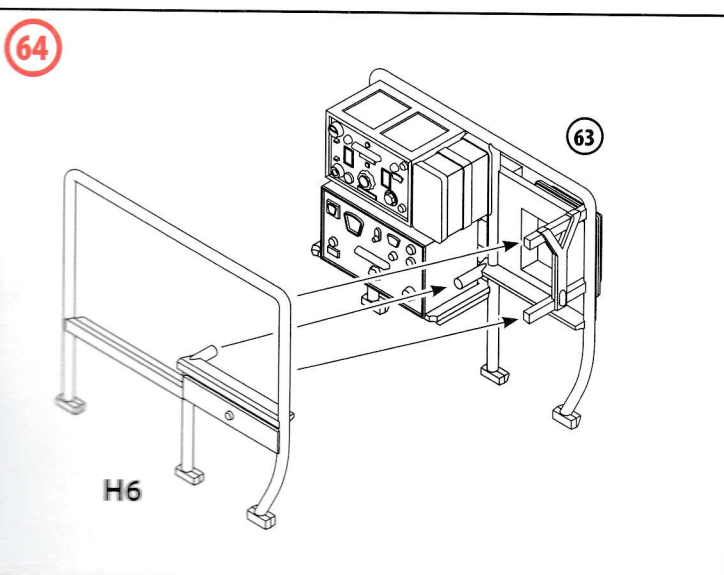
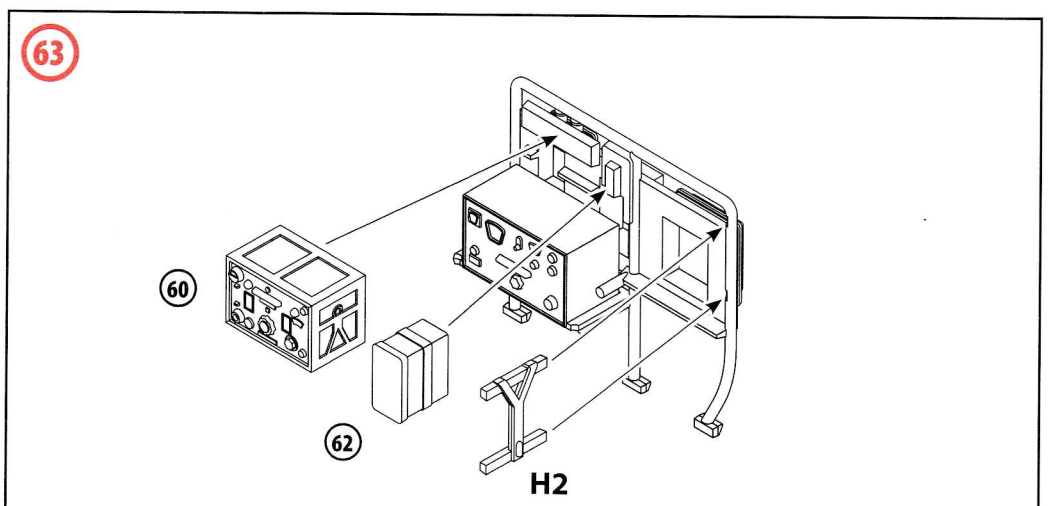
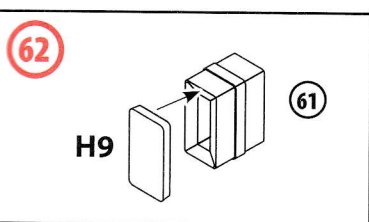
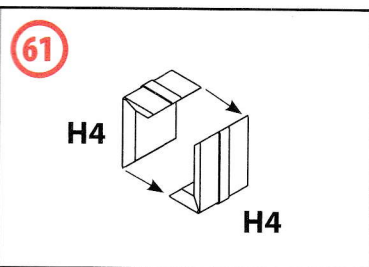
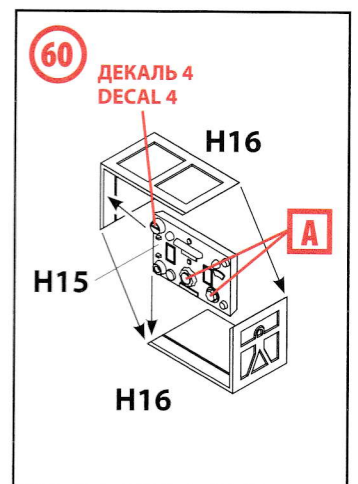
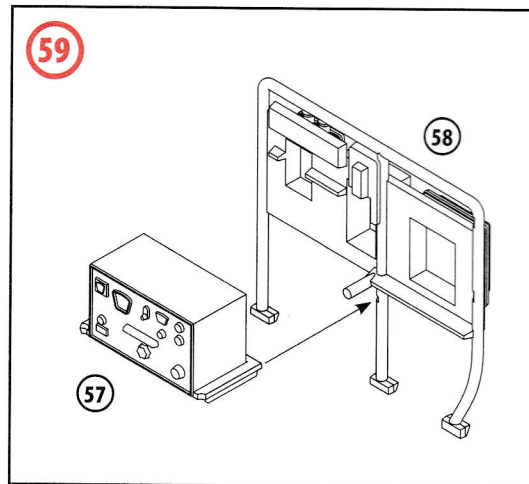
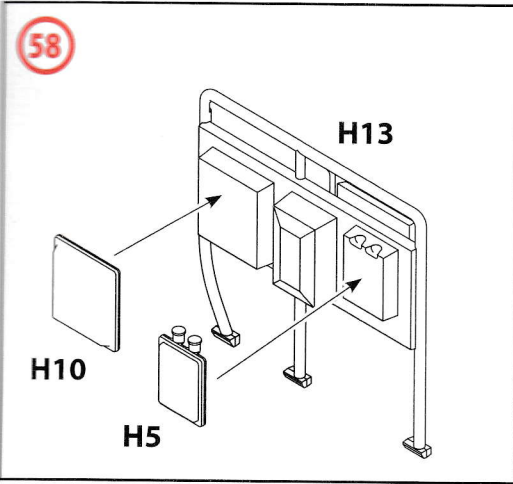
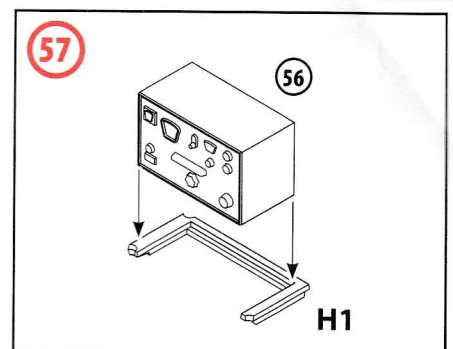
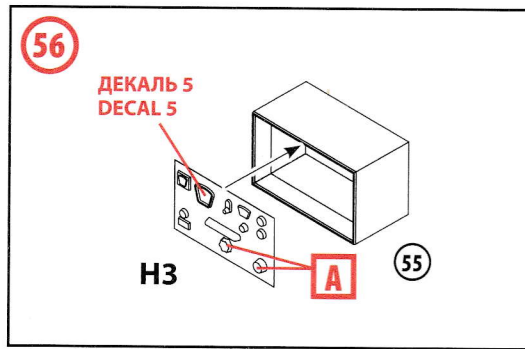
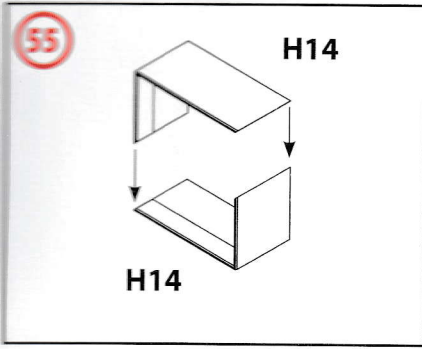

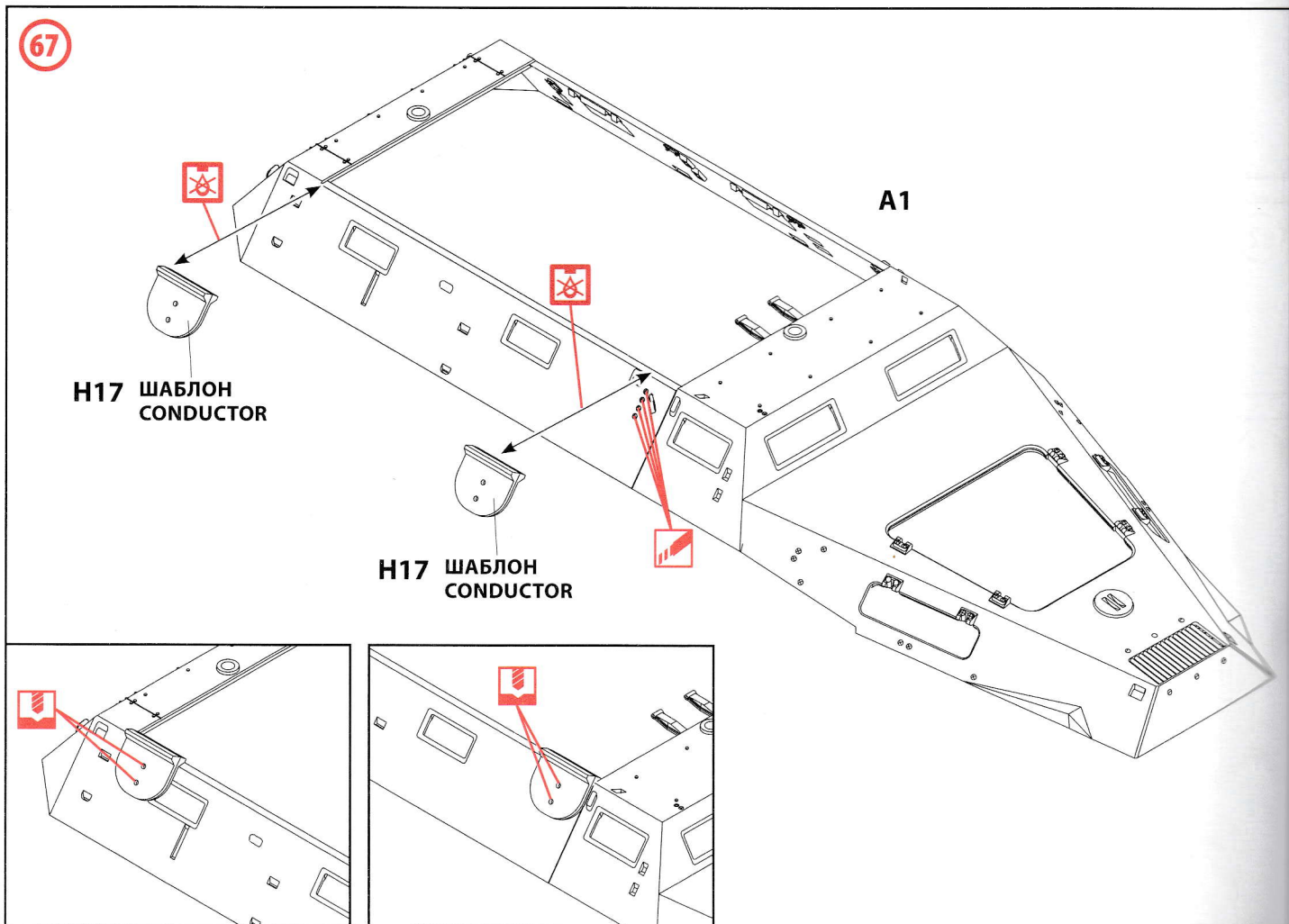
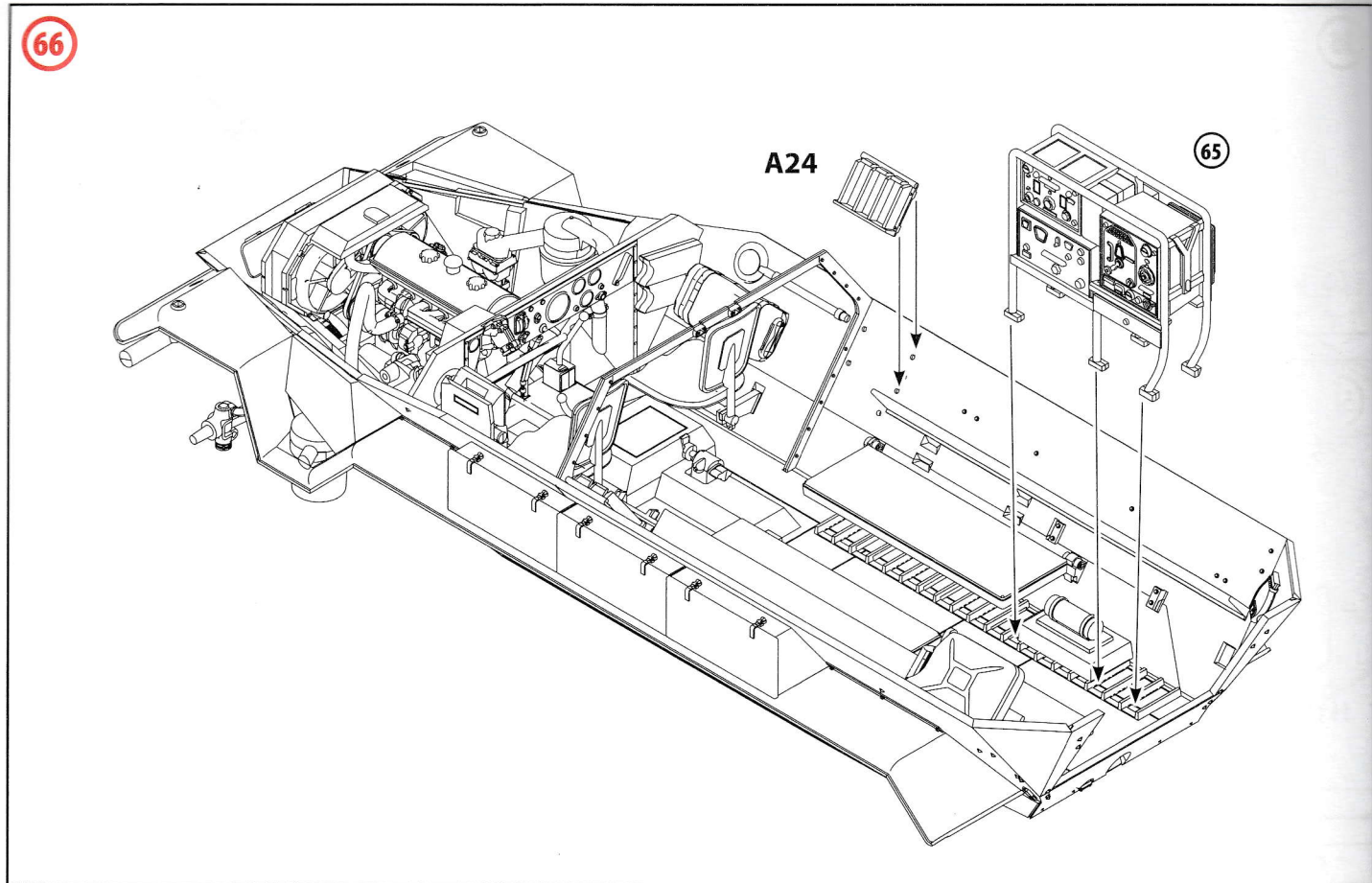



68

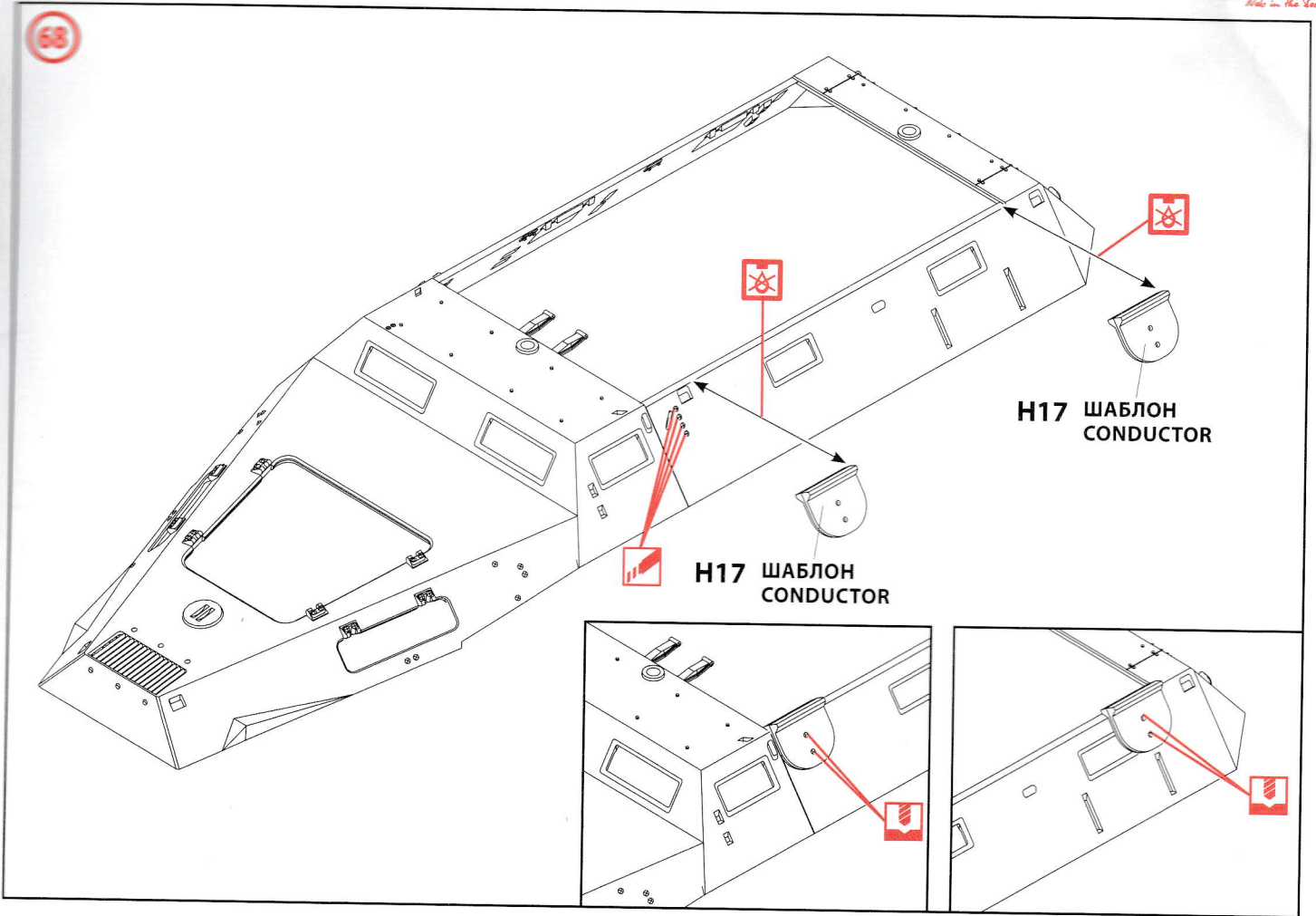

69

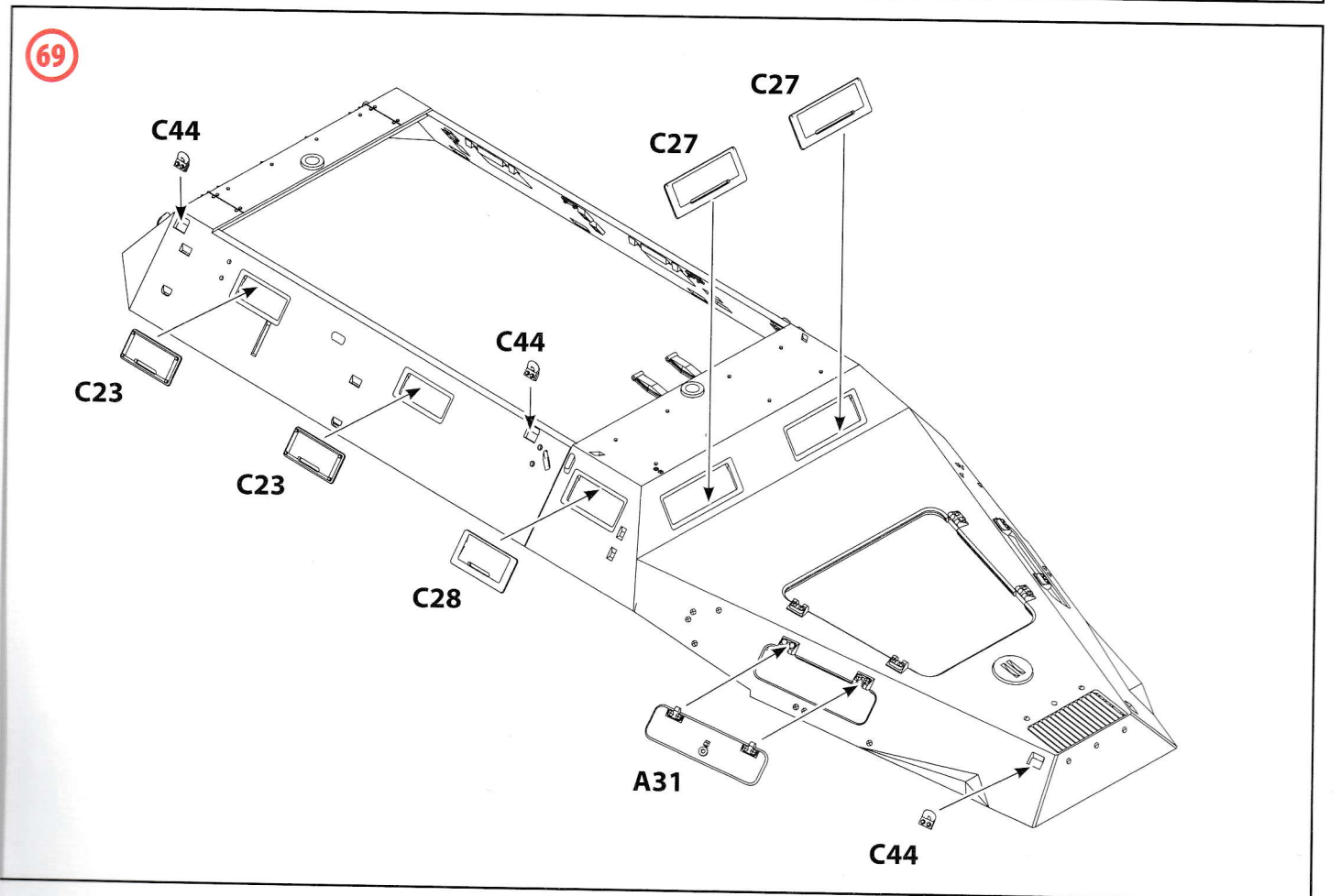

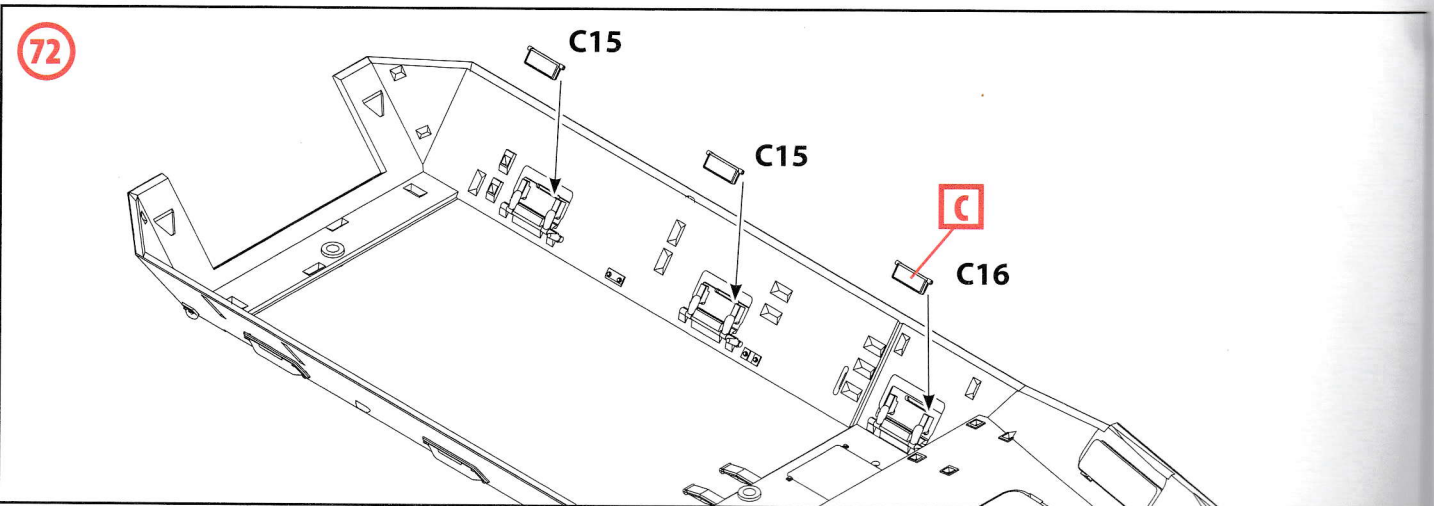
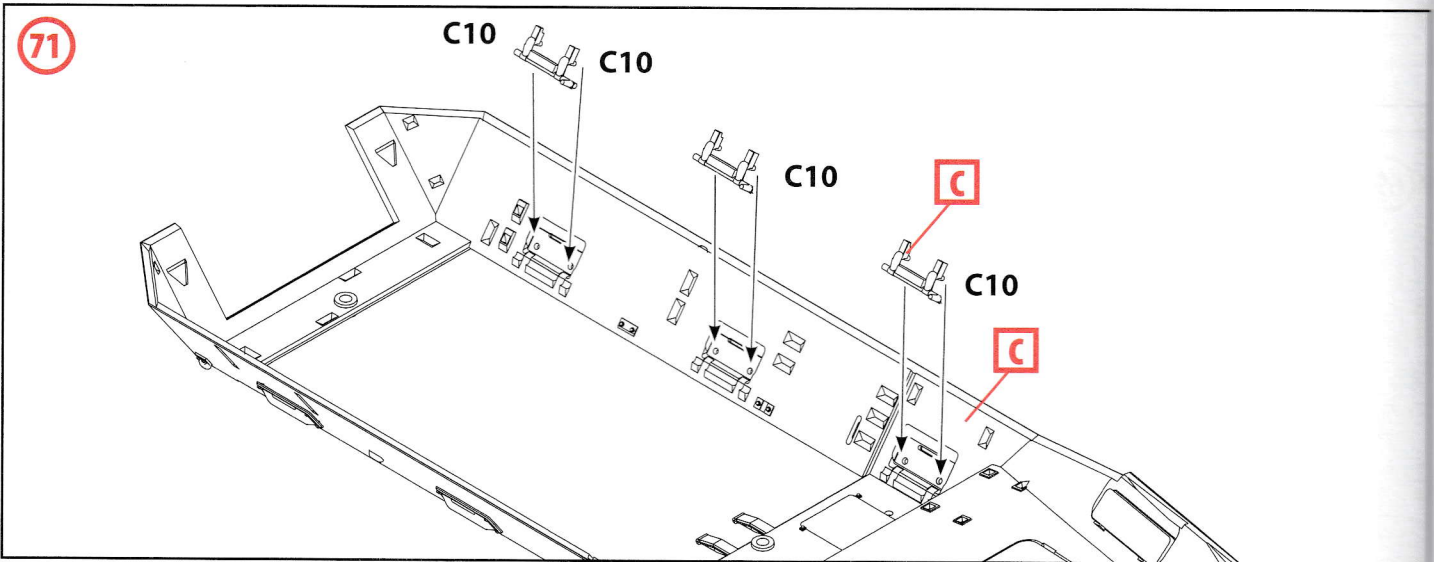
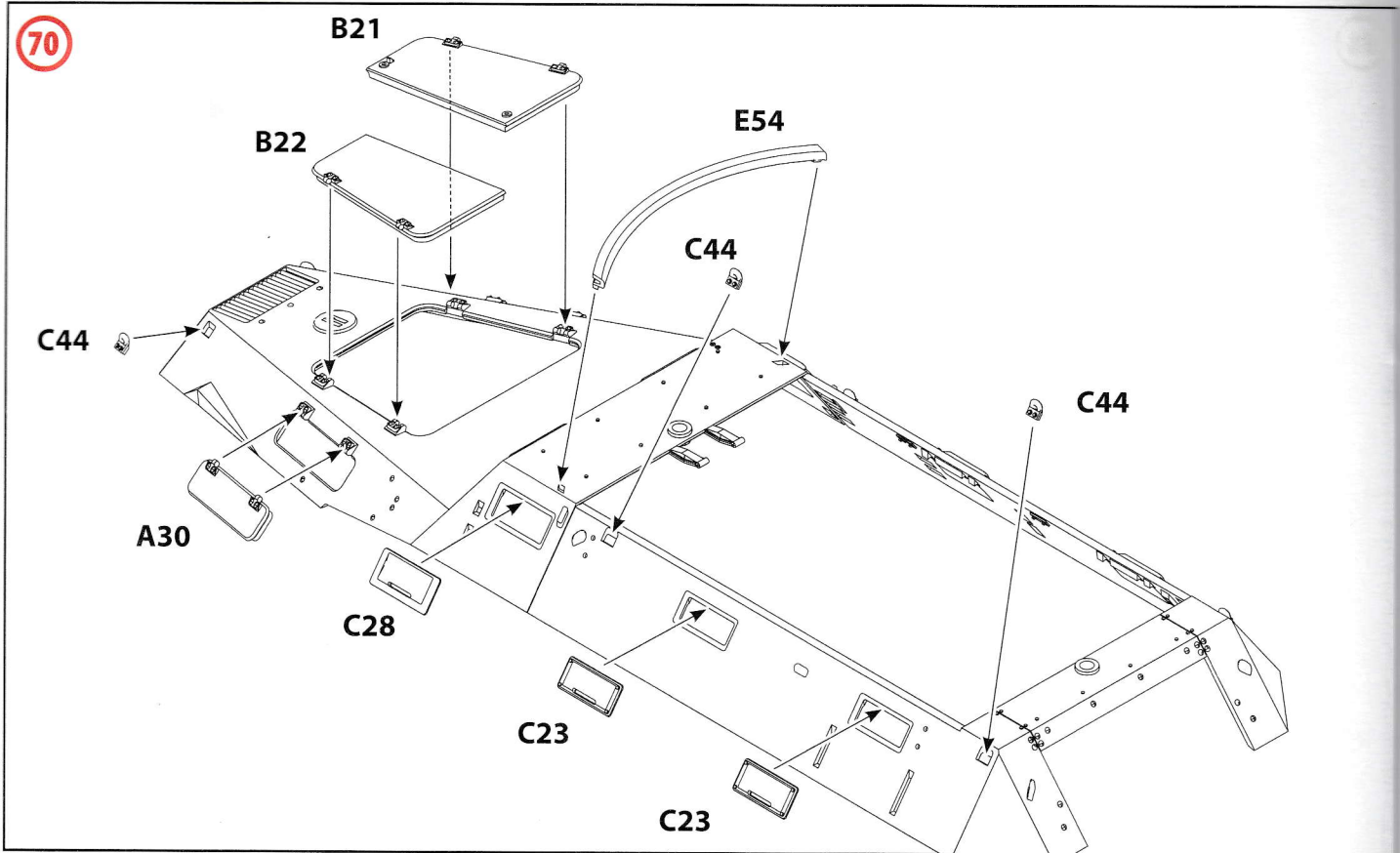



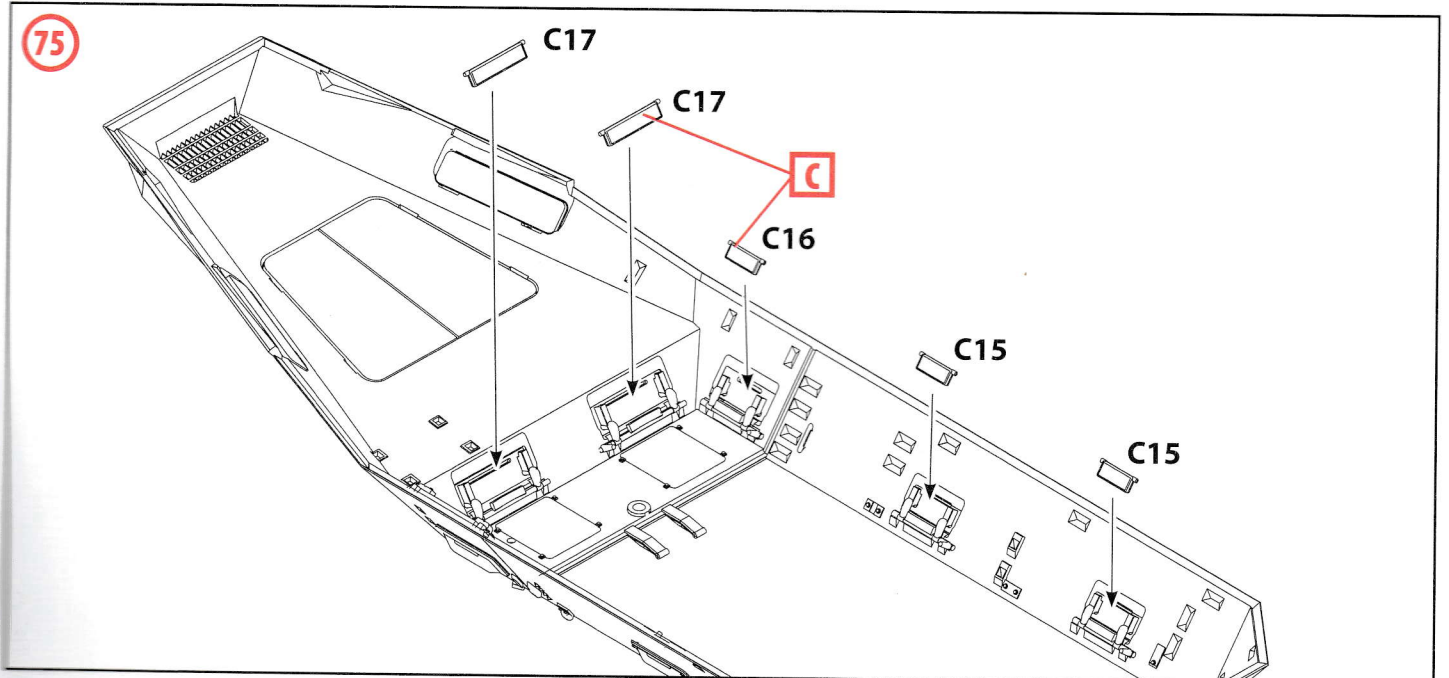
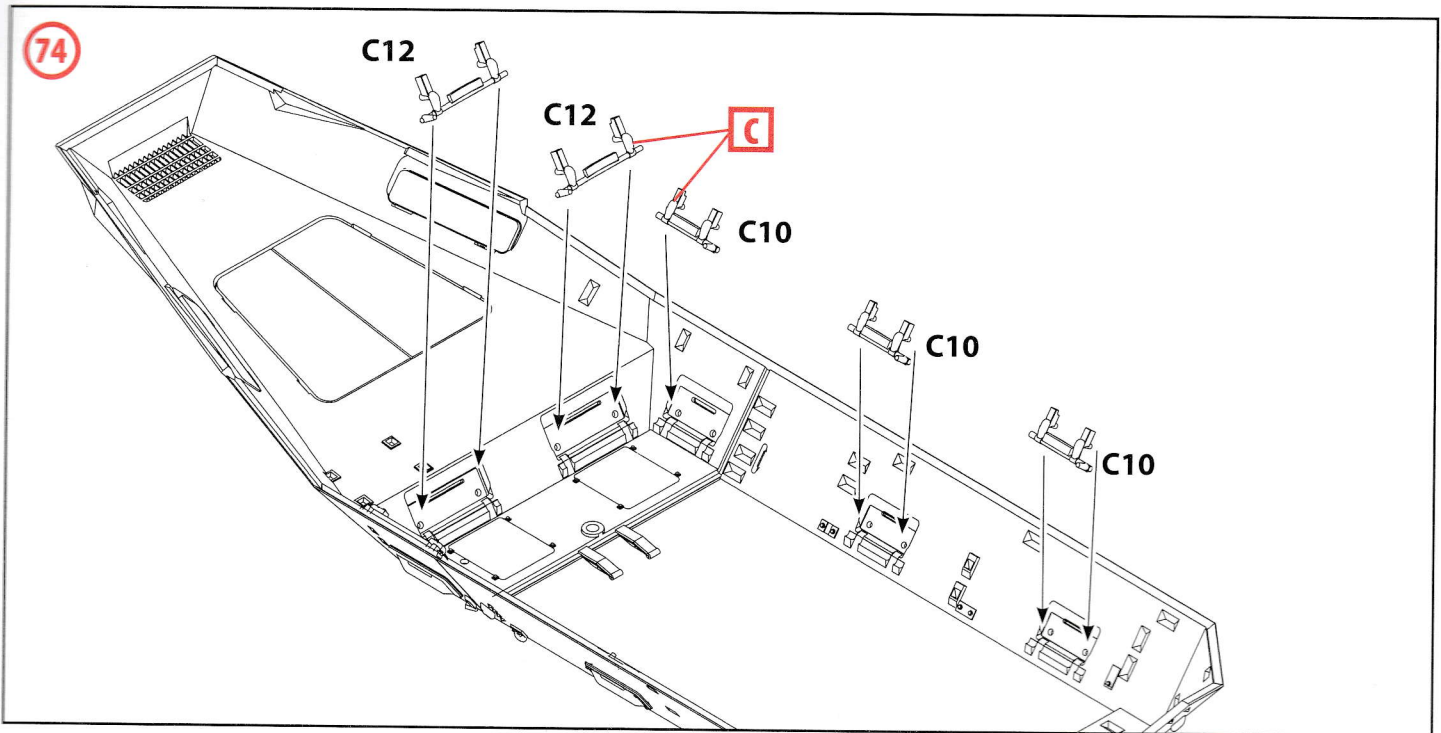
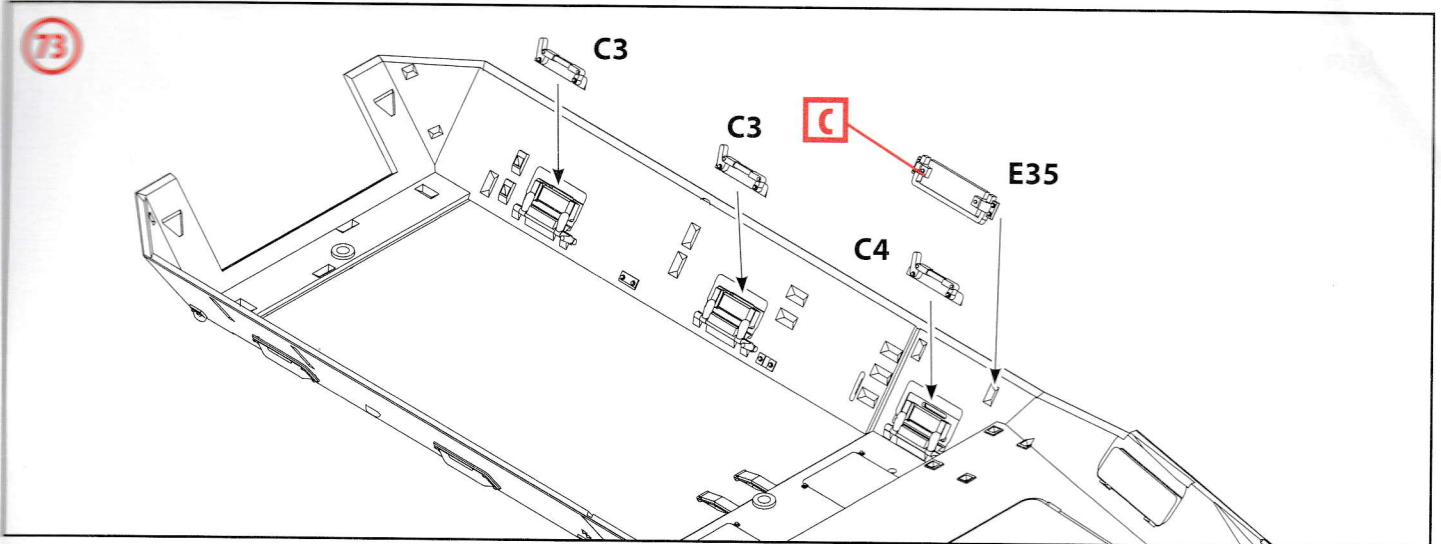

76

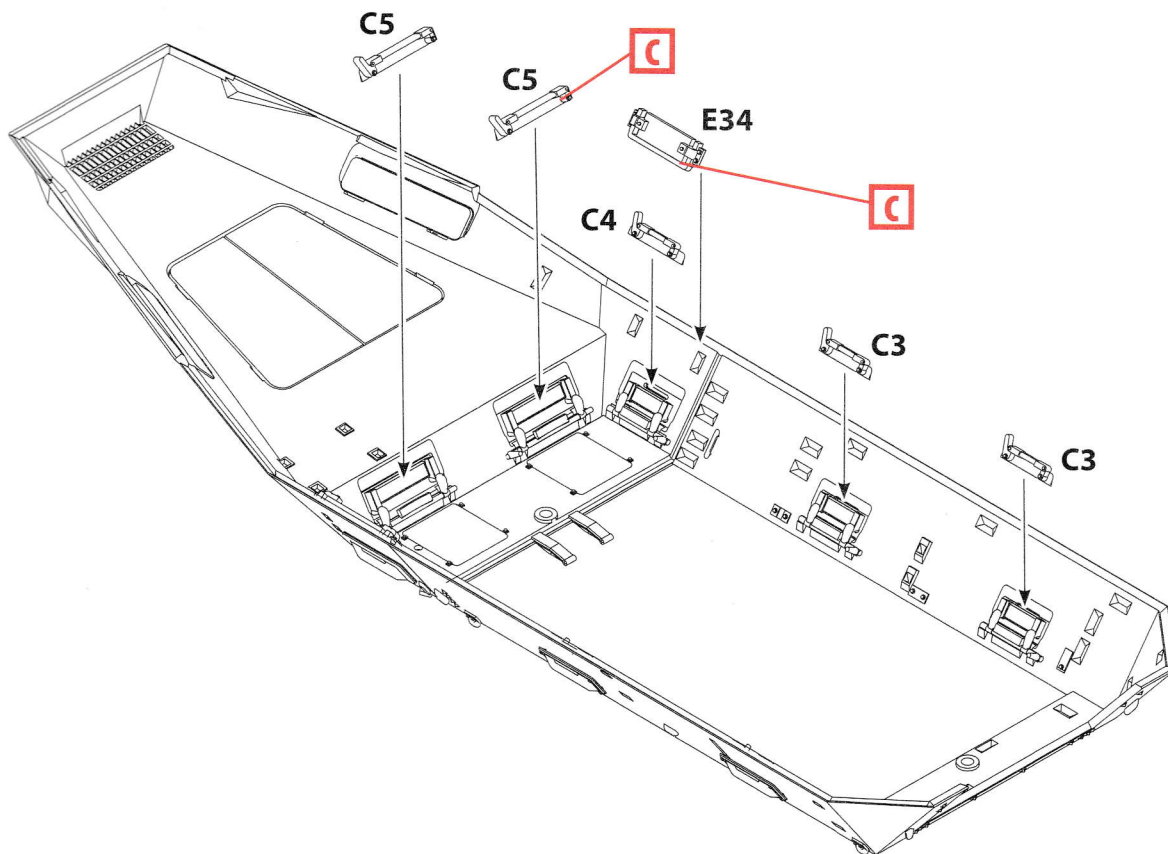

77

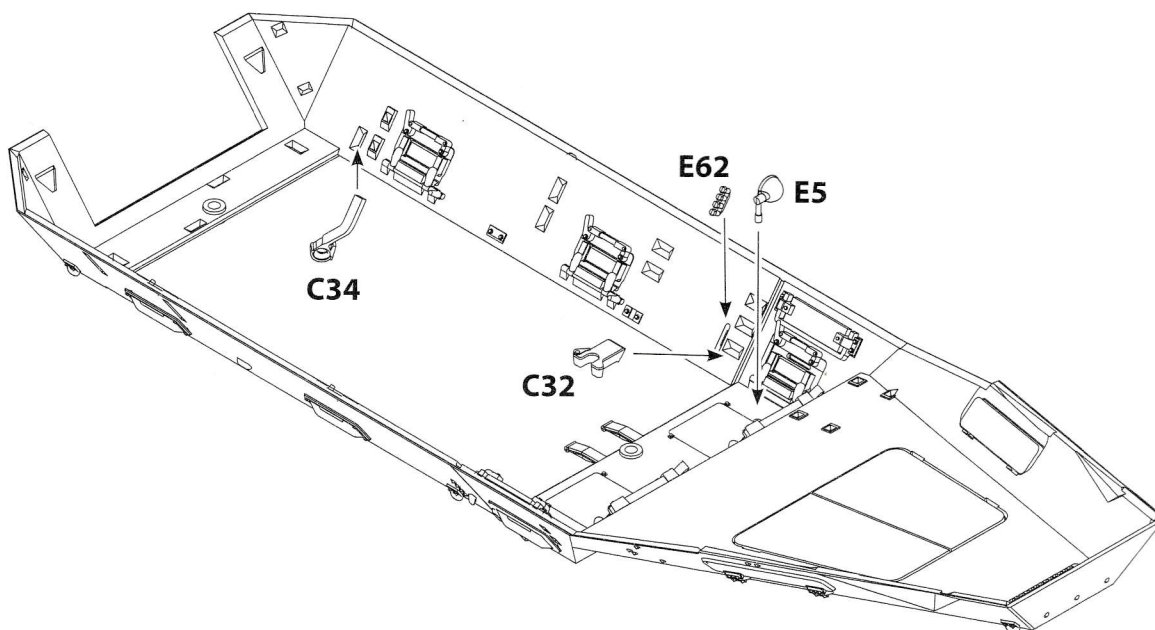



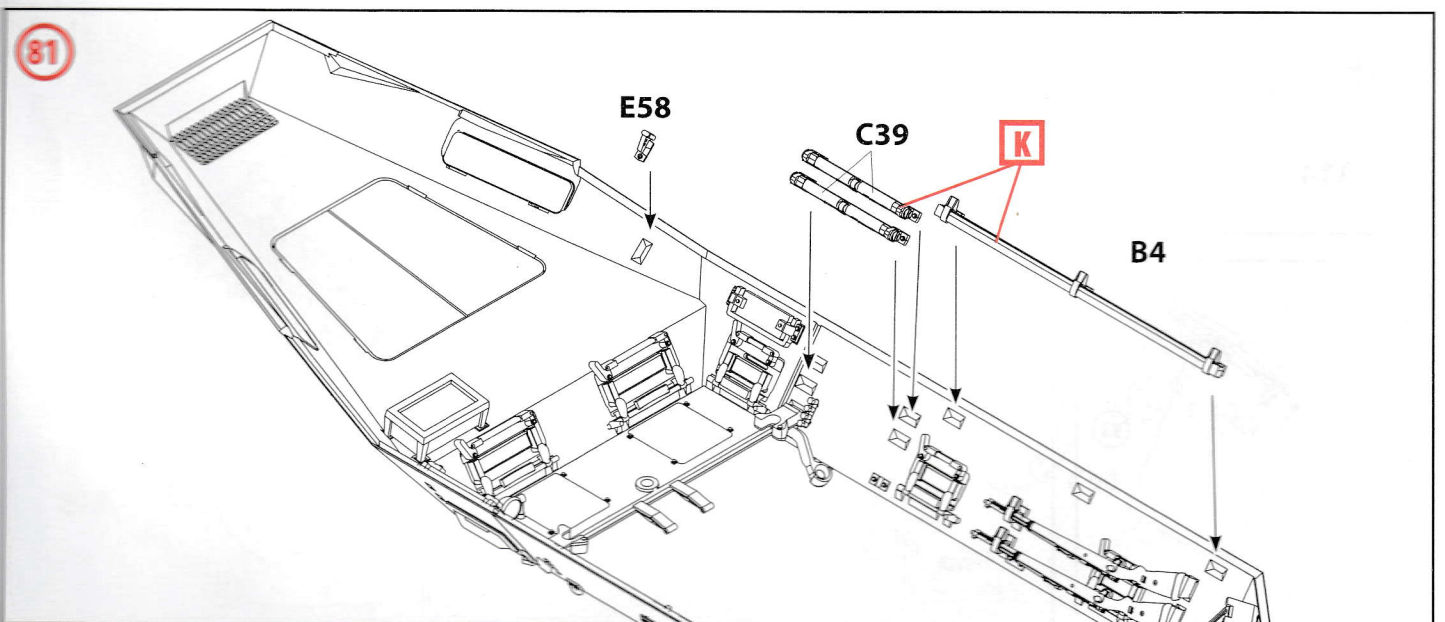
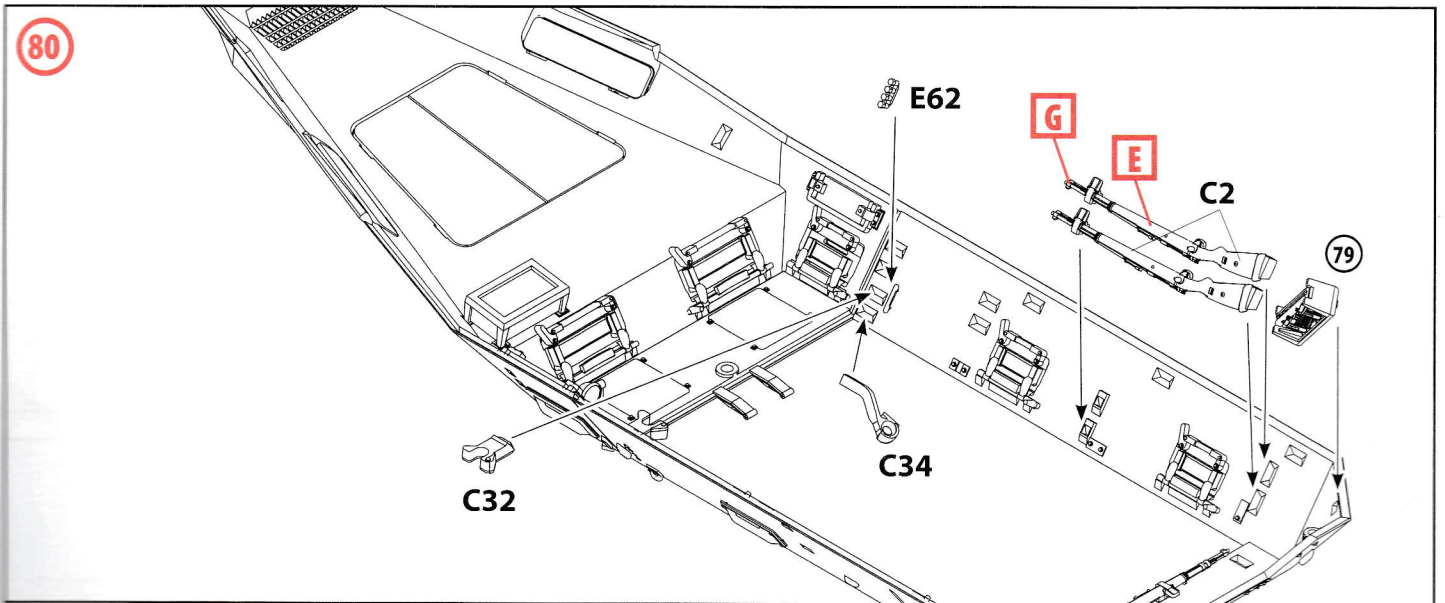
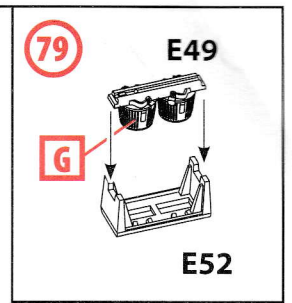
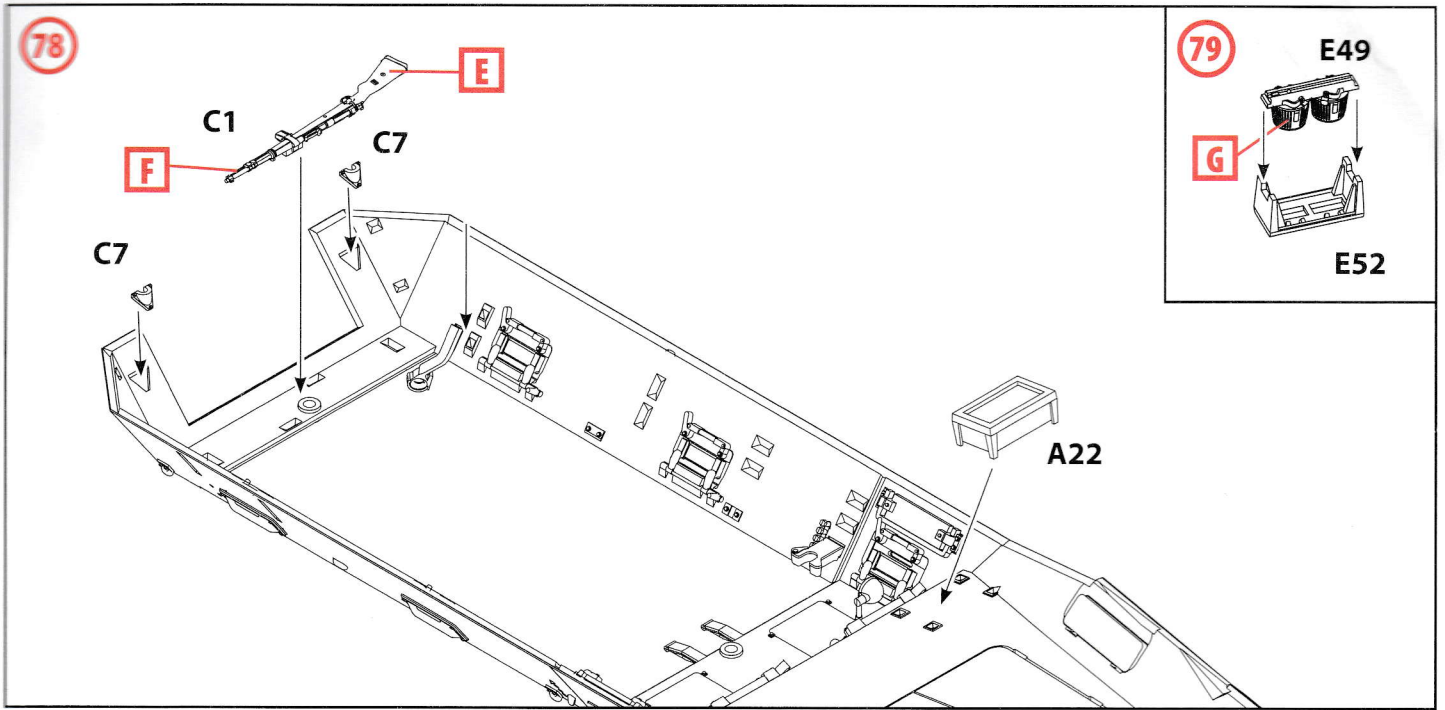

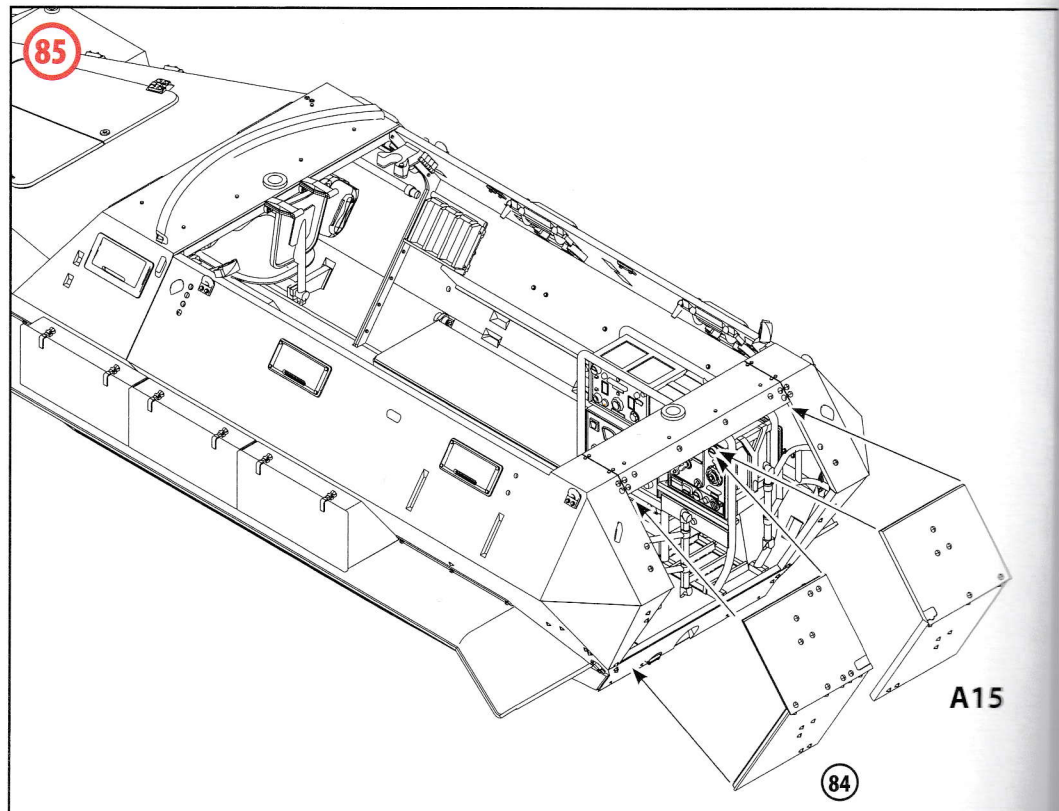
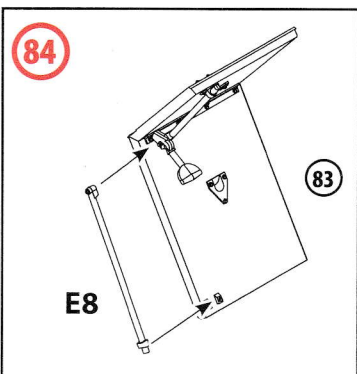
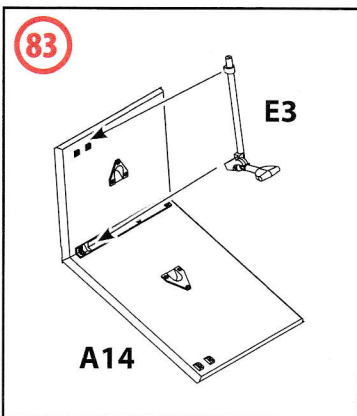
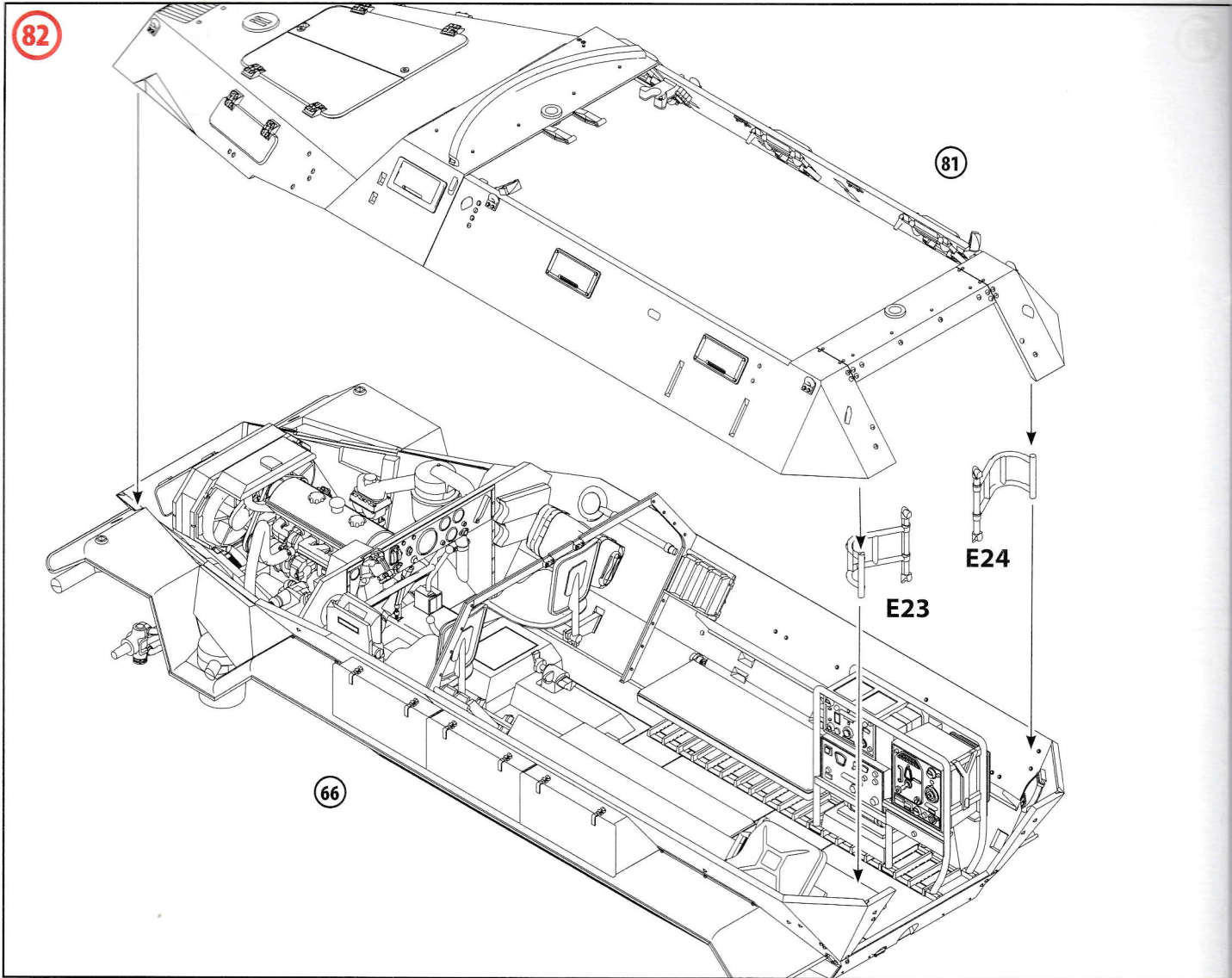



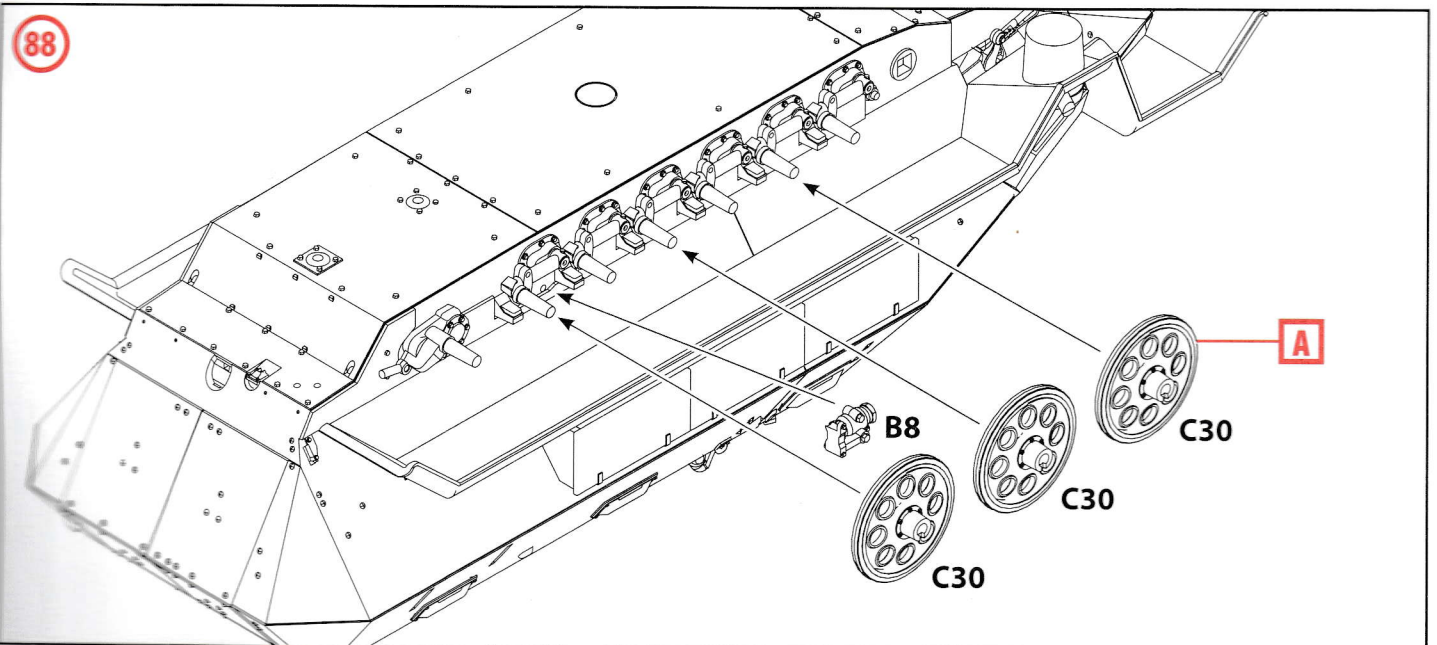
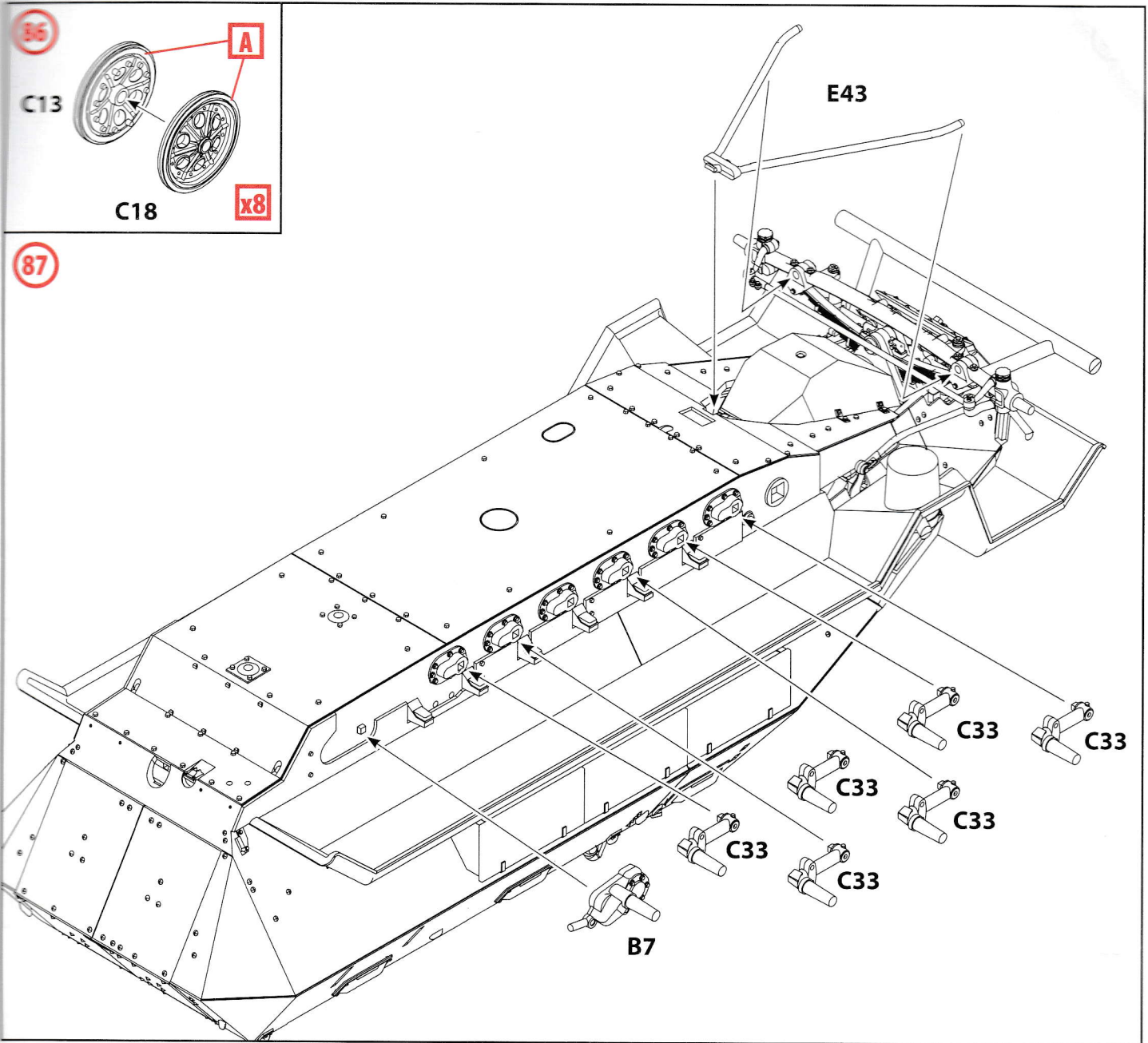

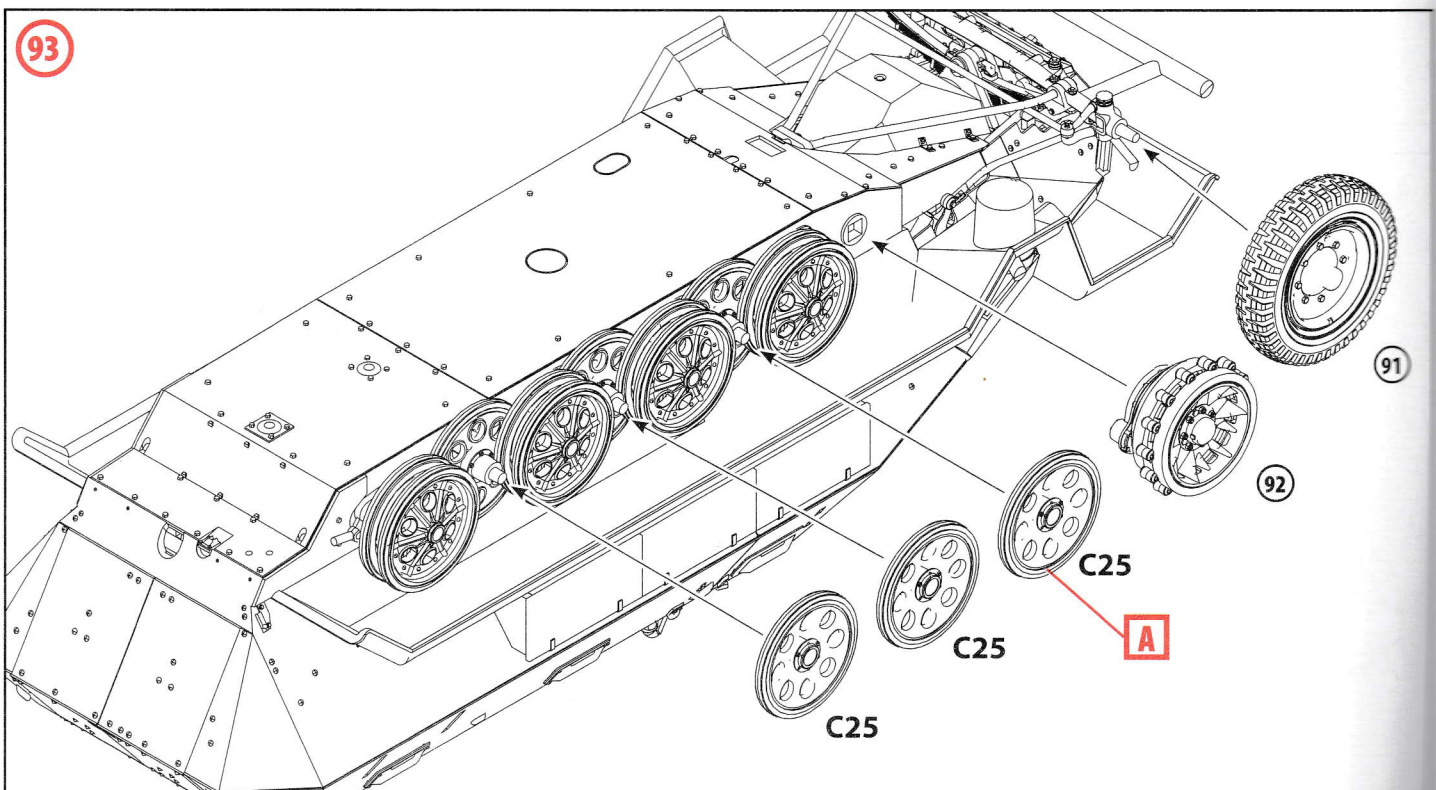
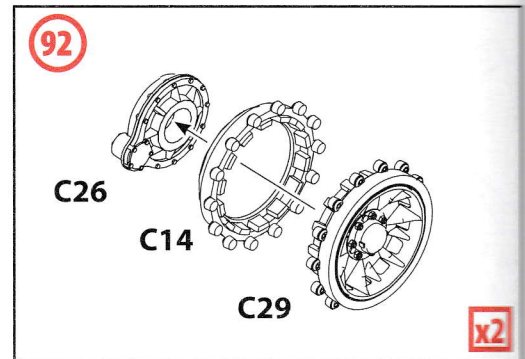
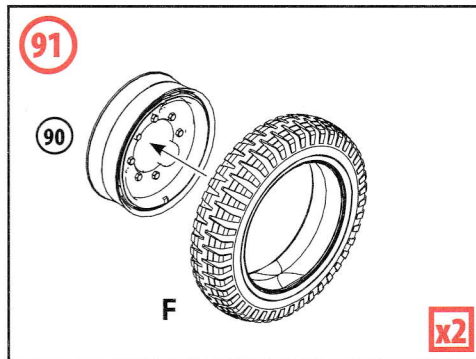
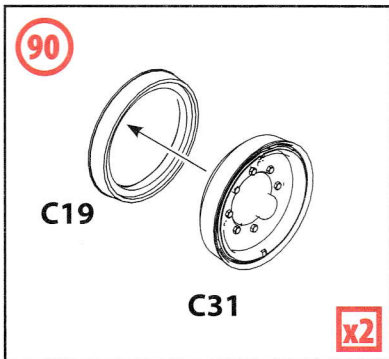
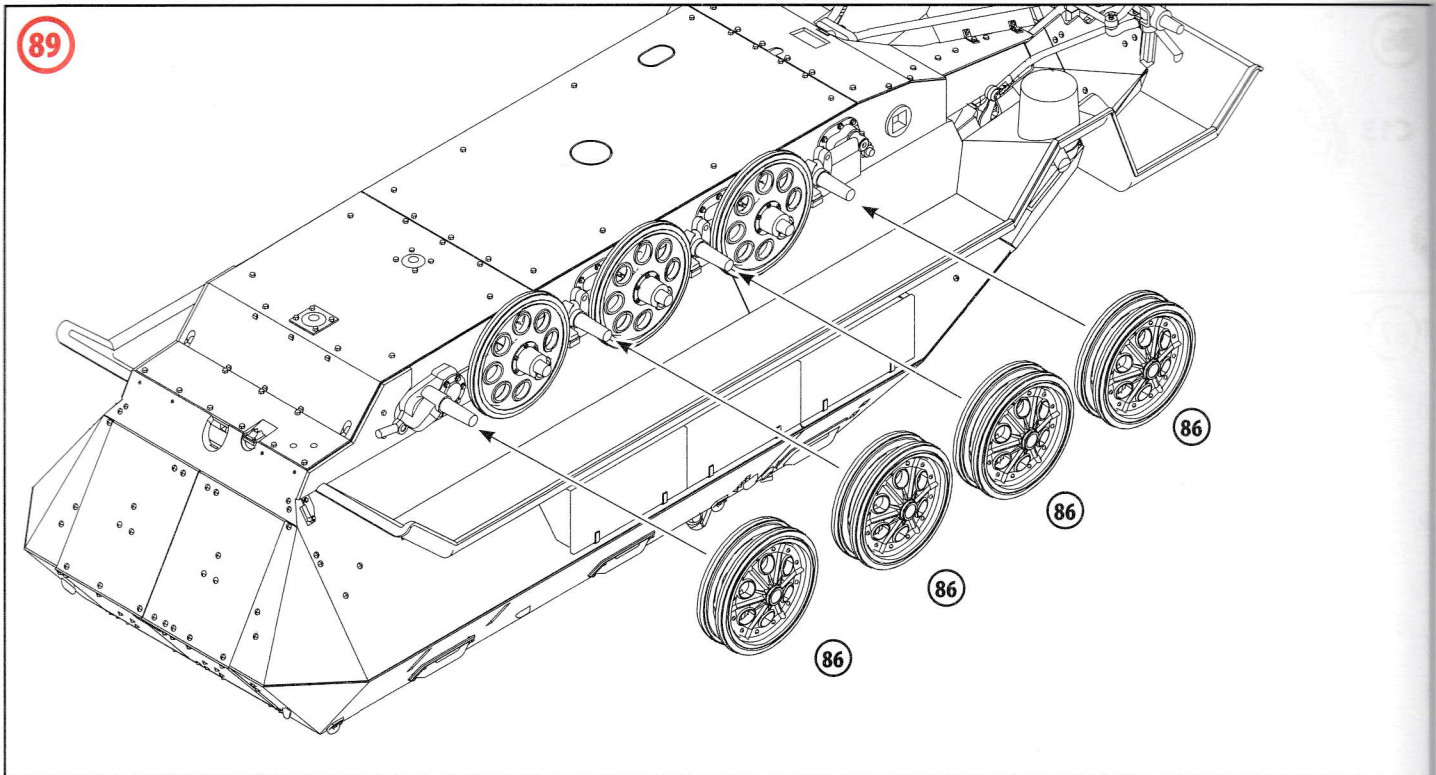



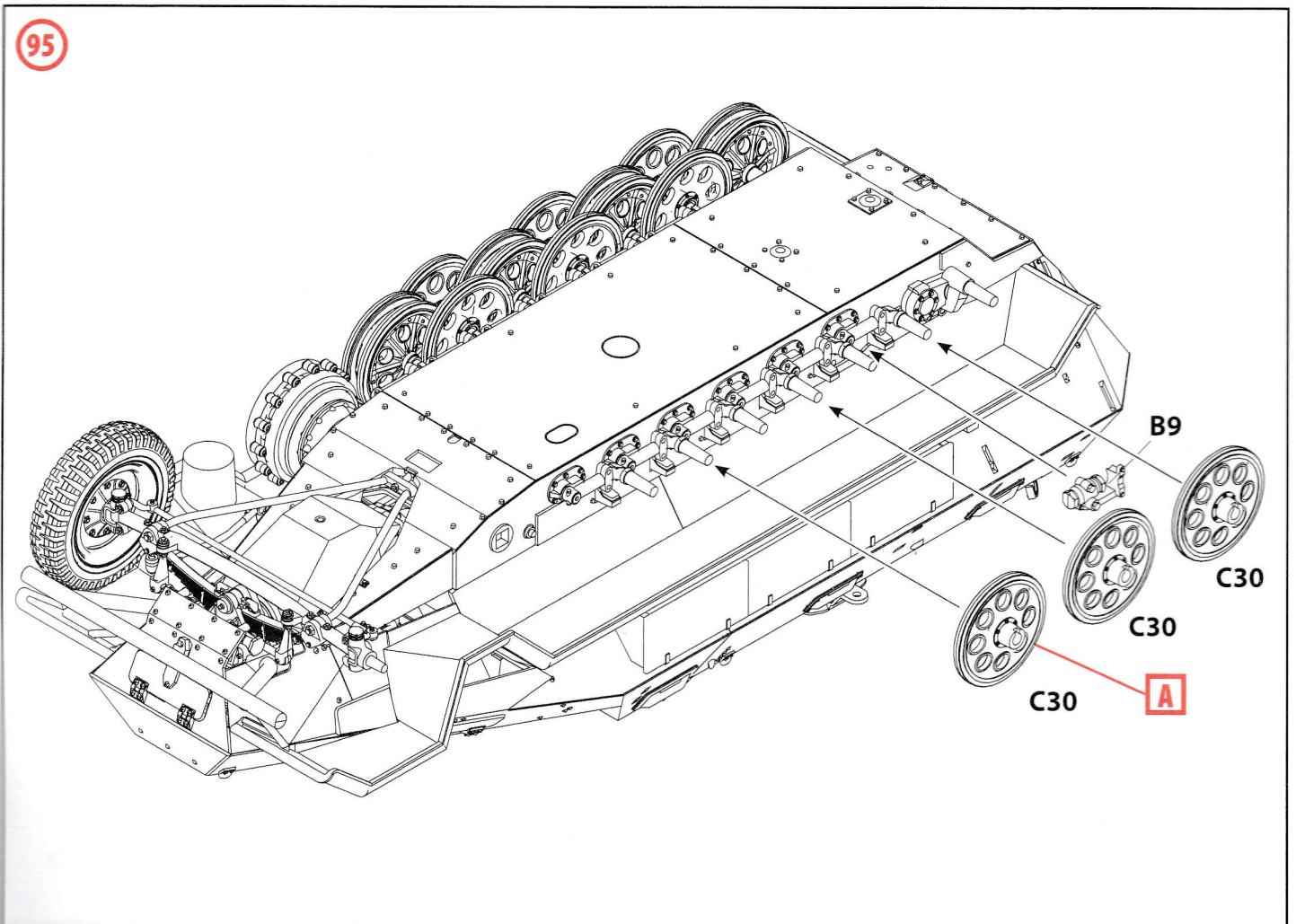
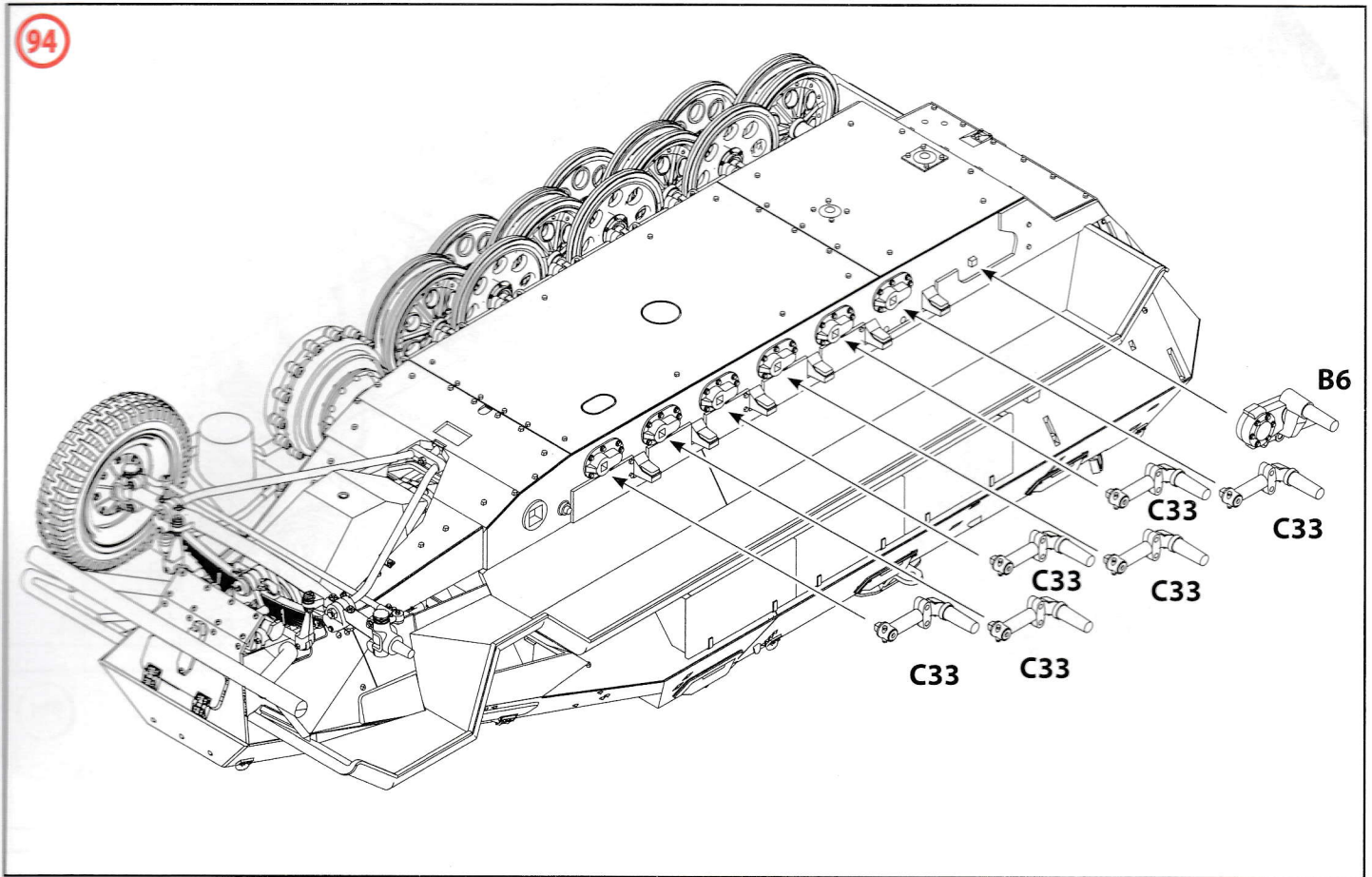



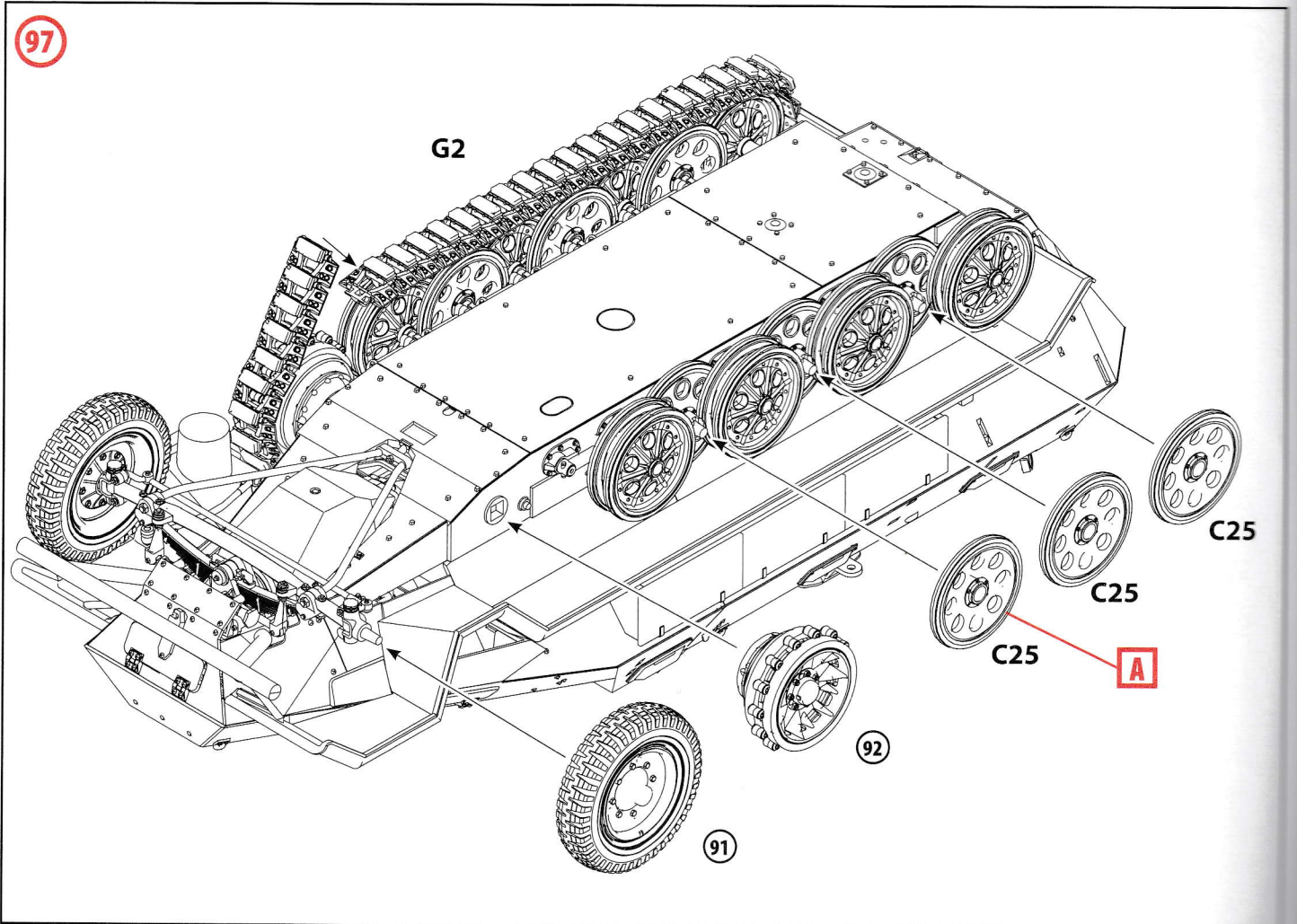
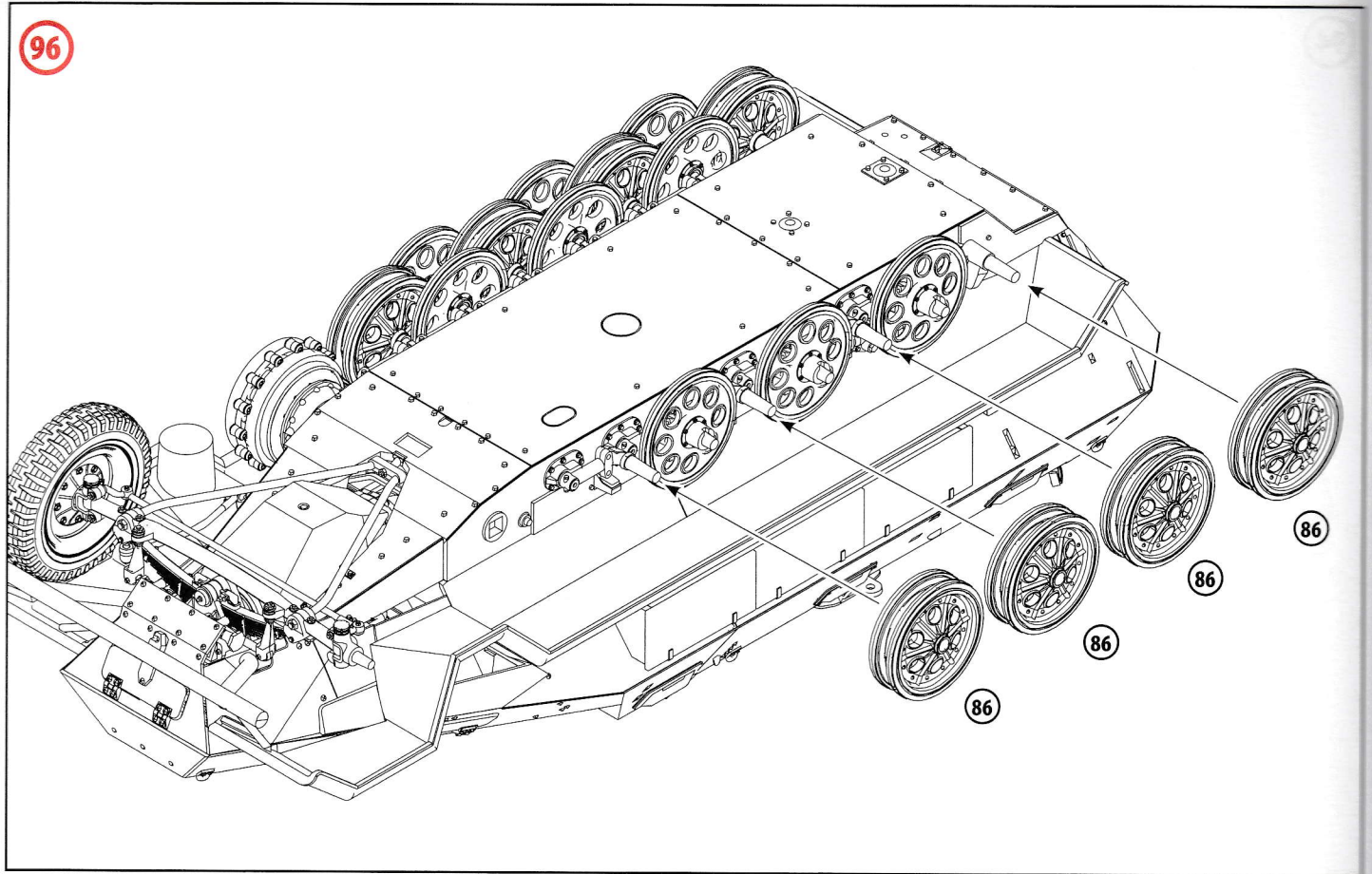



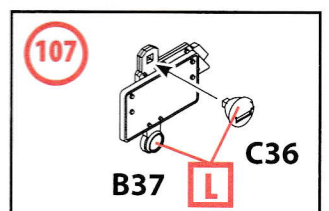
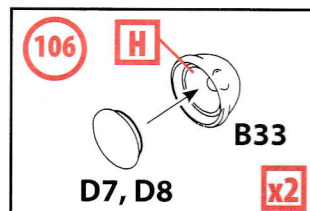
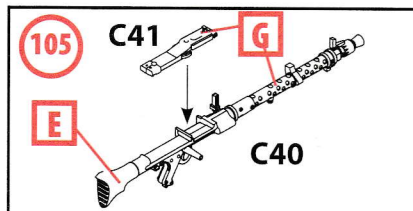
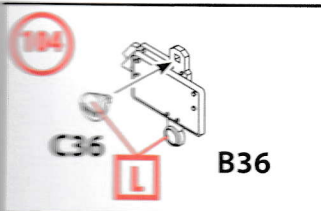
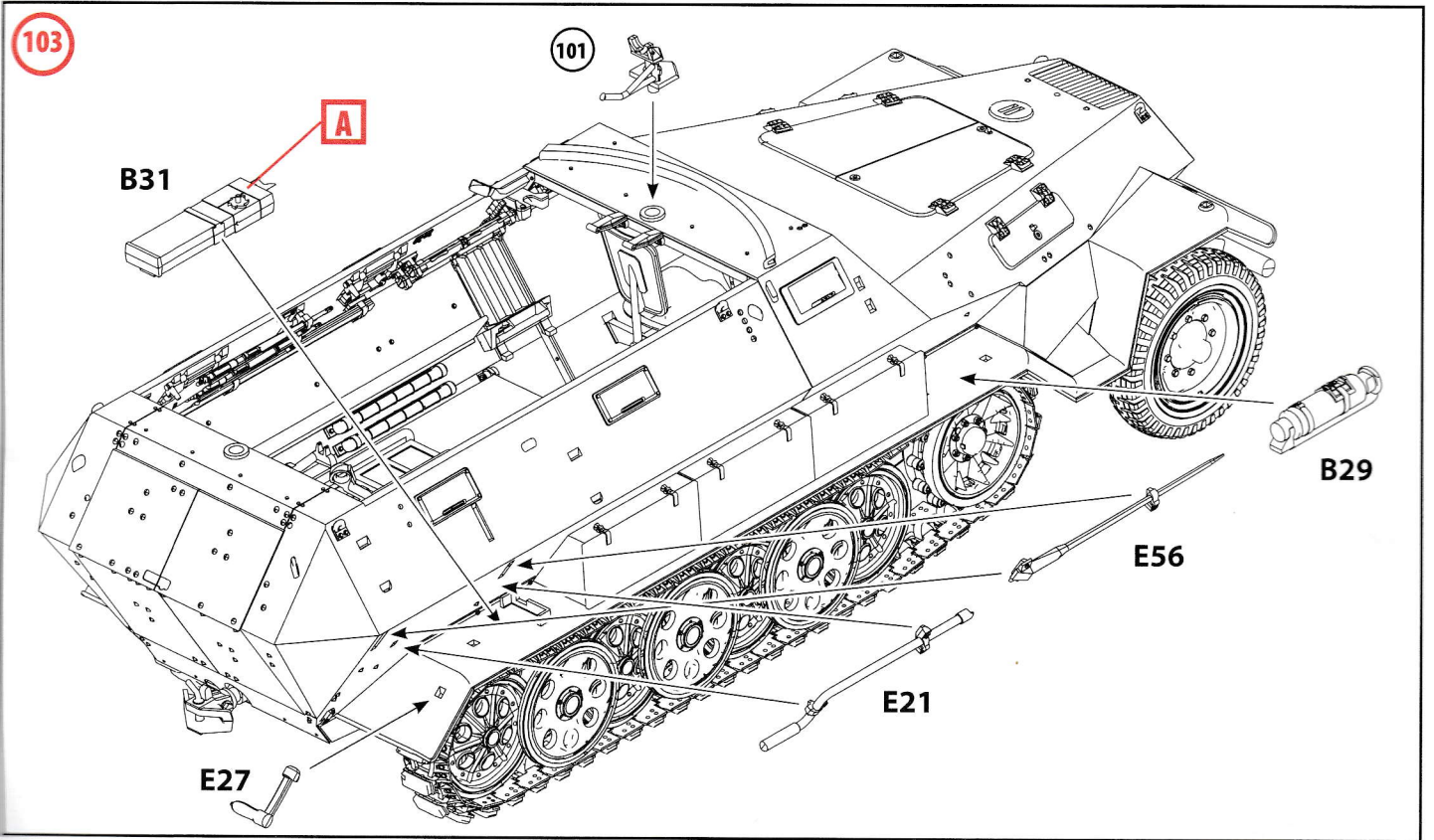
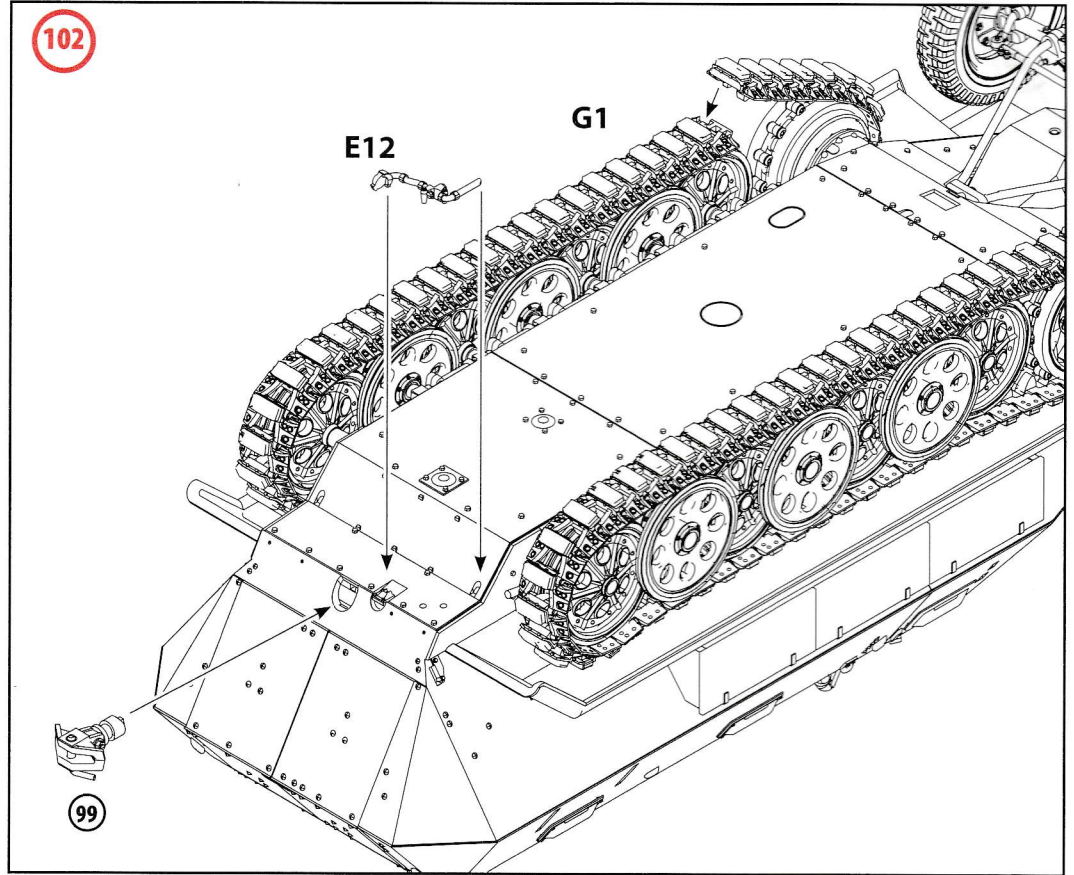
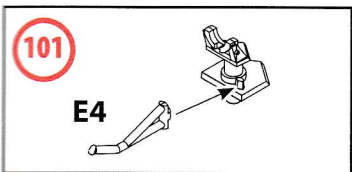
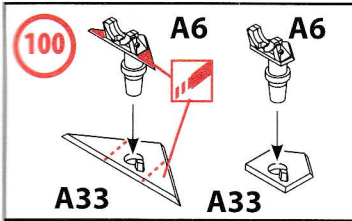
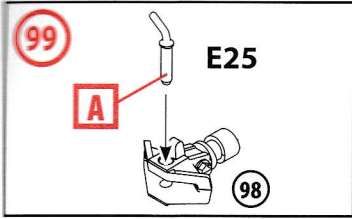
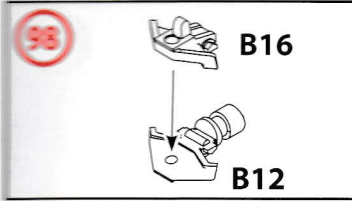



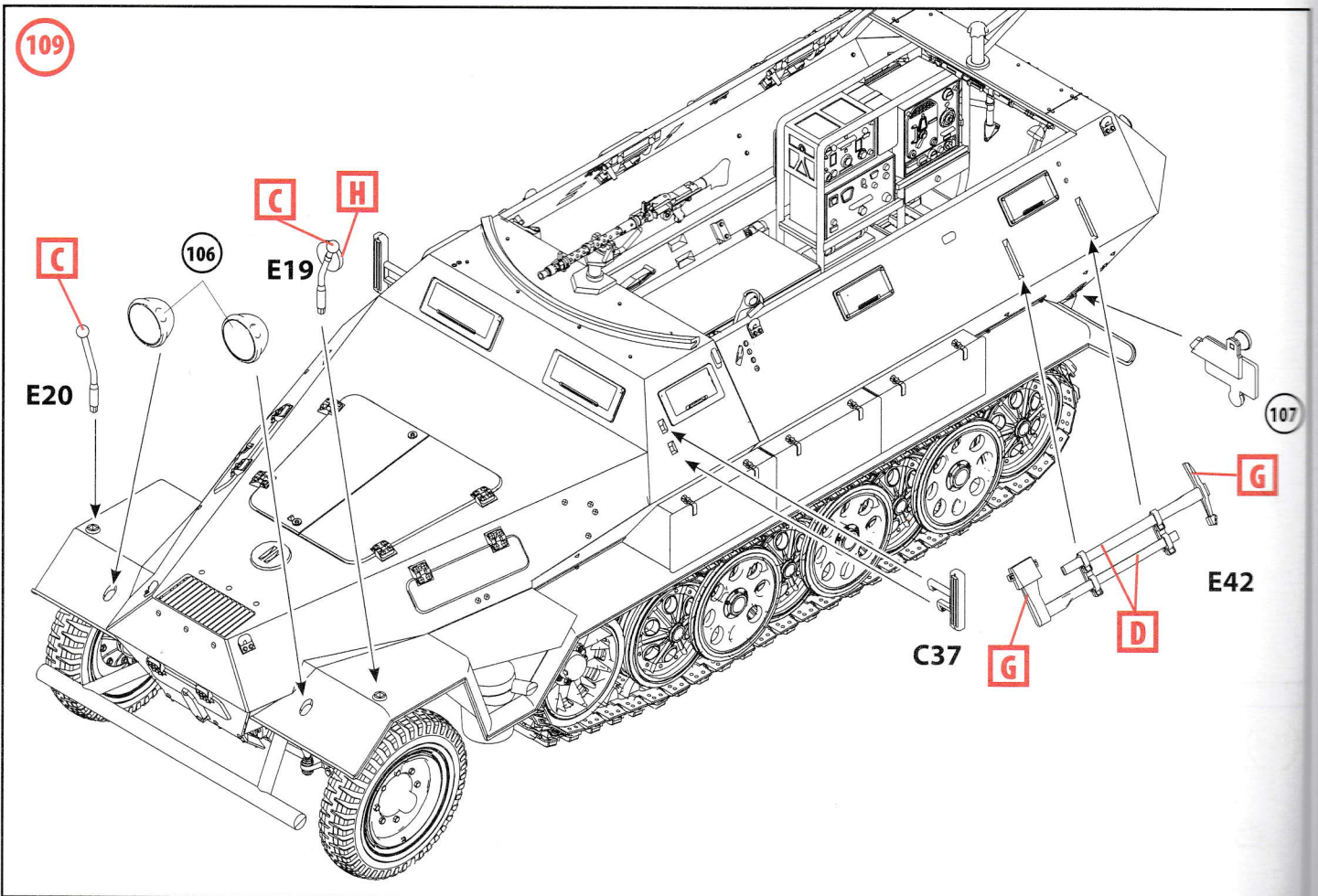
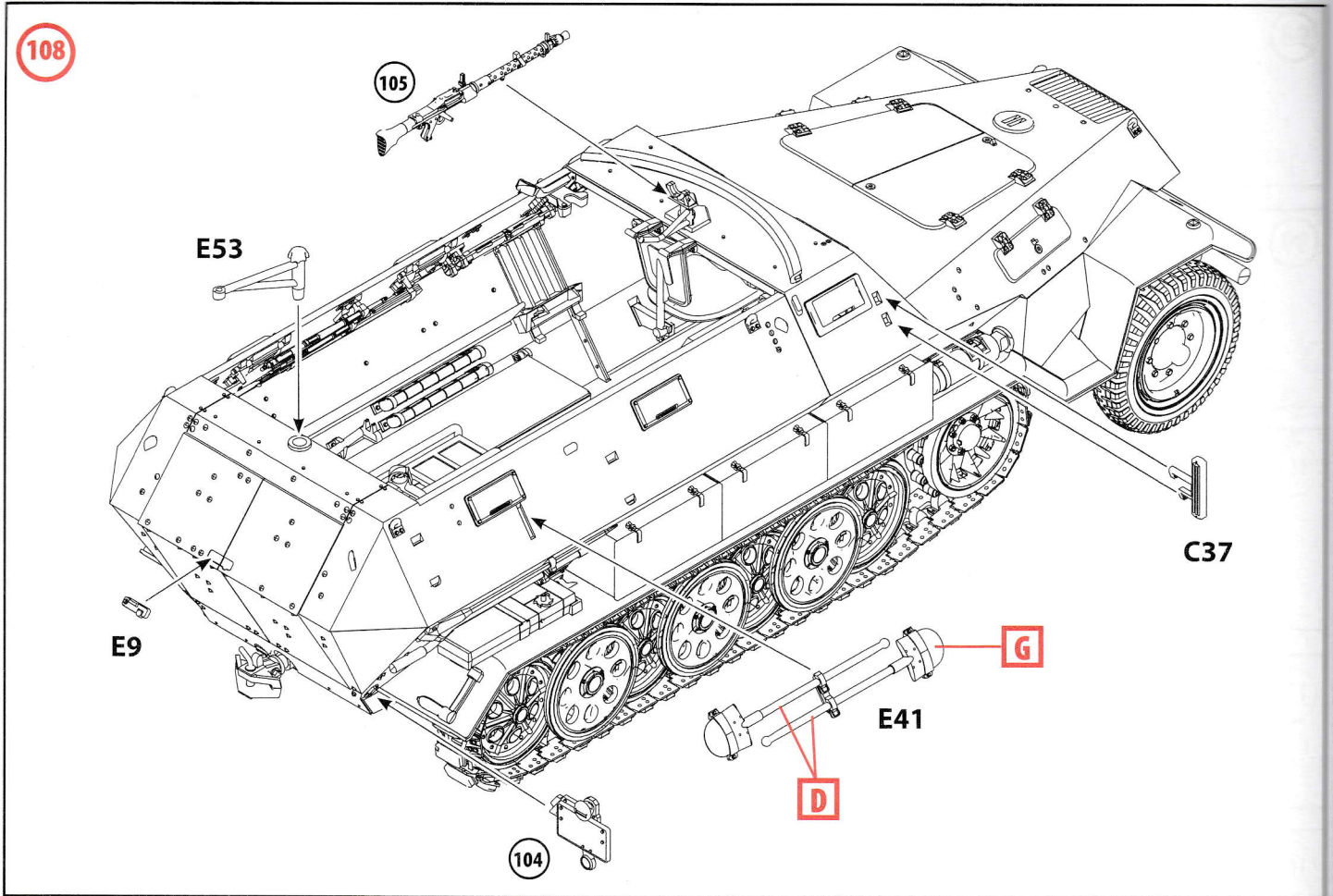



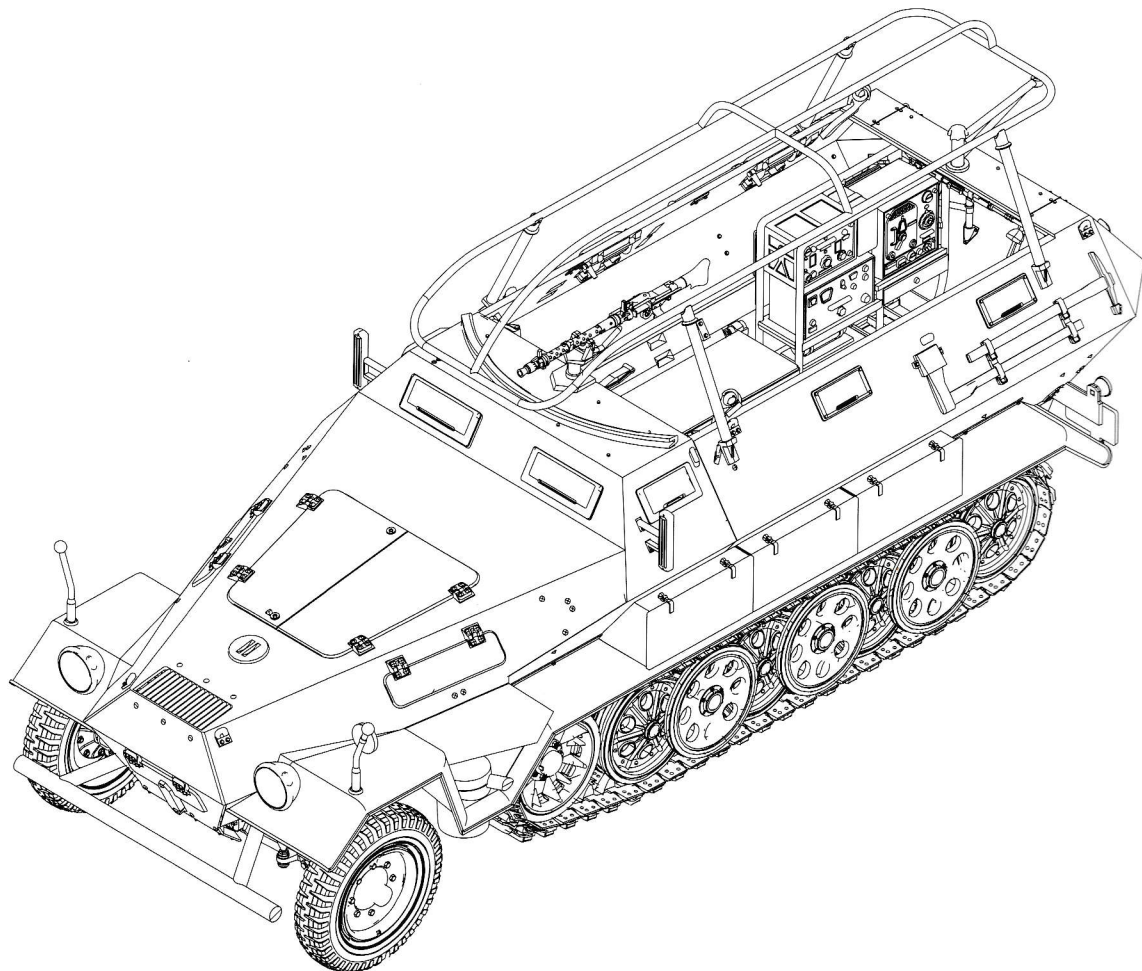
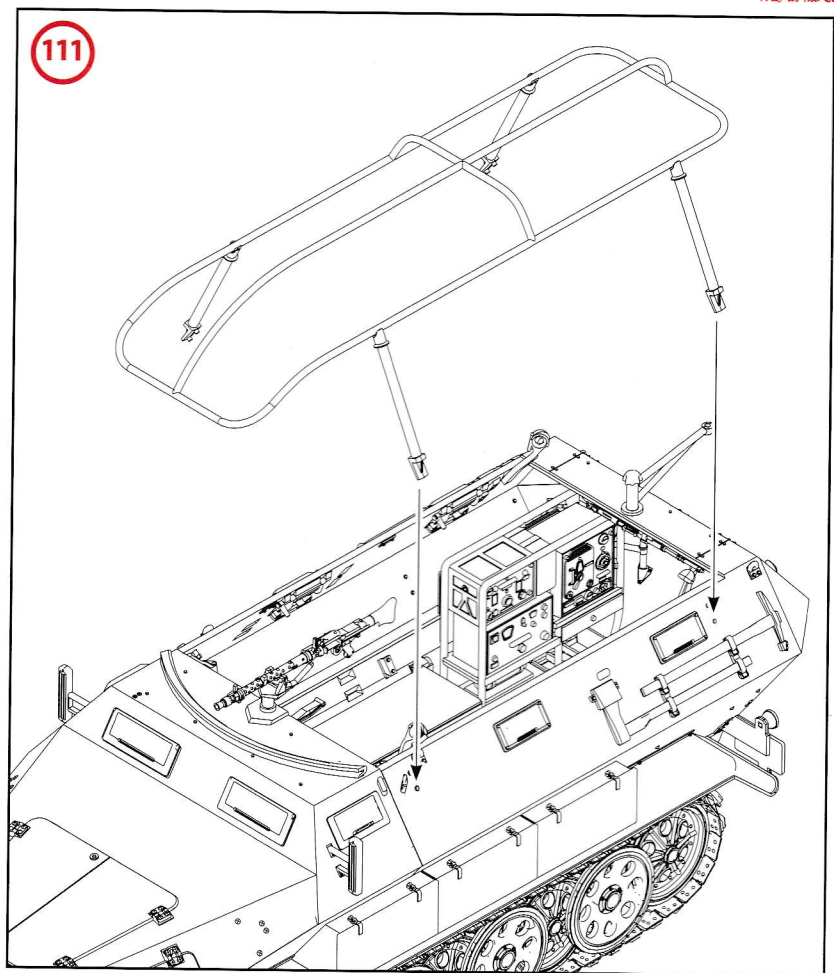
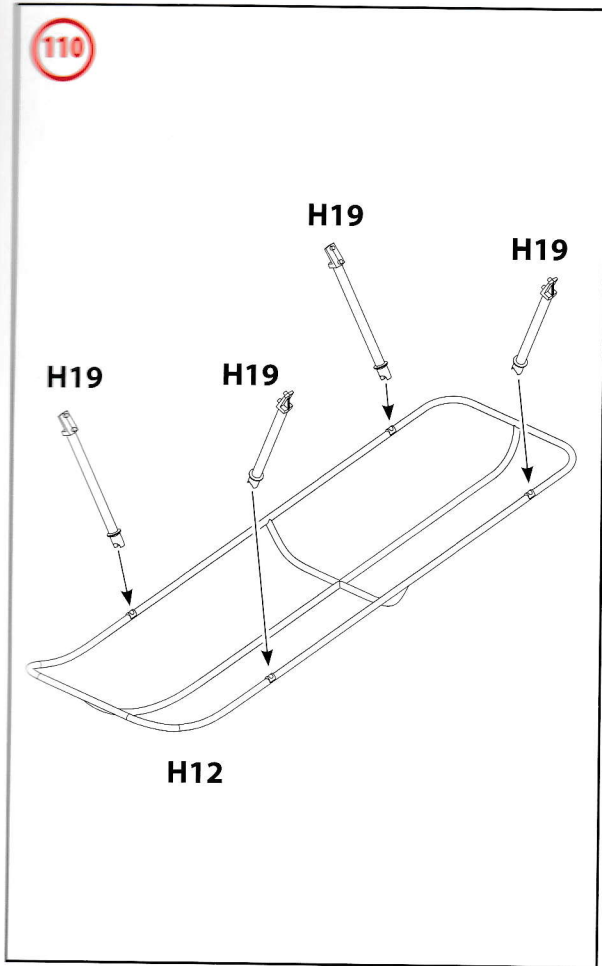



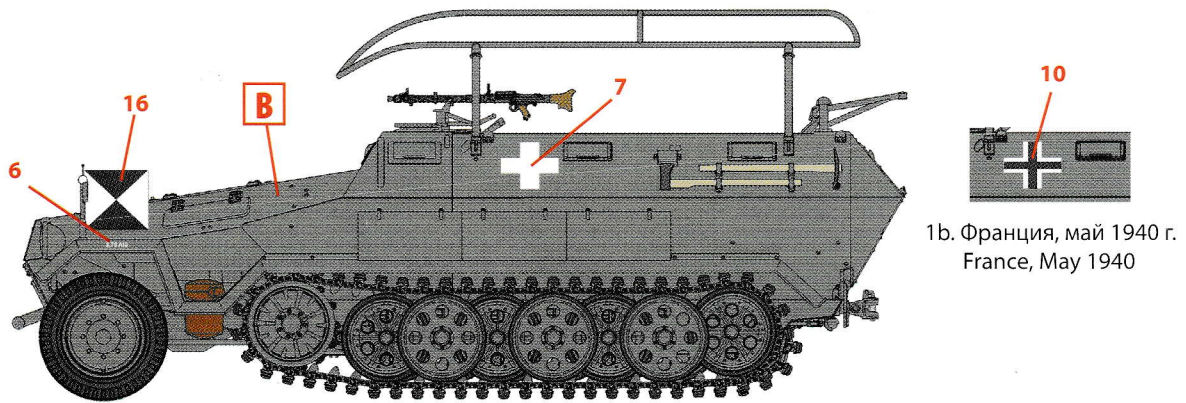
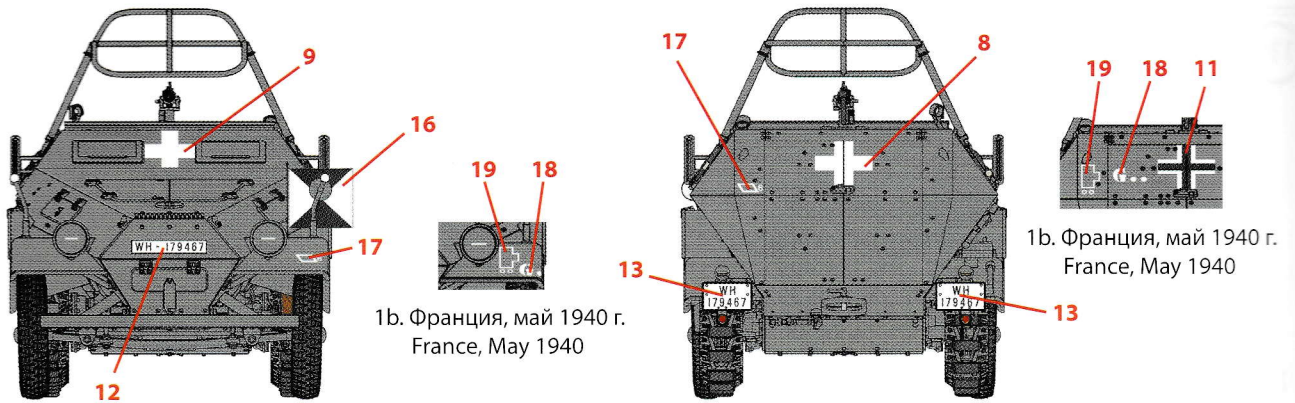

1a. Sd.Kfz.251/6 Ausf.A, командная машина генерал-лейтенанта Г. Гудериана, Польша, сентябрь 1939 г.  
Sd.Kfz.251/6 Ausf.A, command vehicle of Lieutenant-General H. Guderian, Poland, September 1939

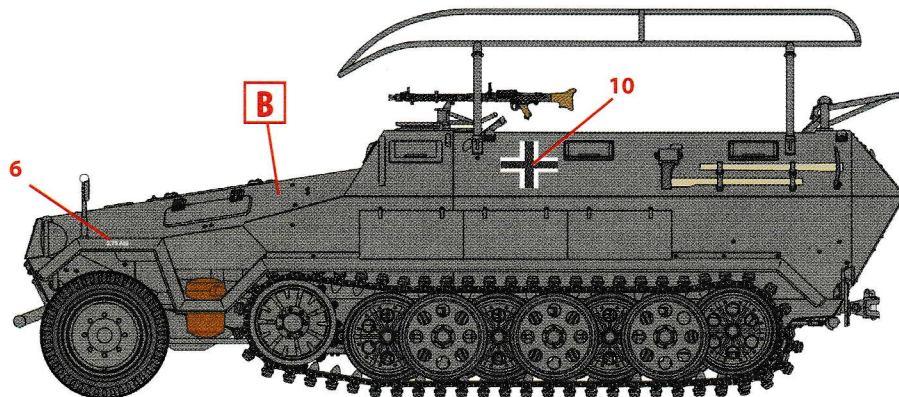
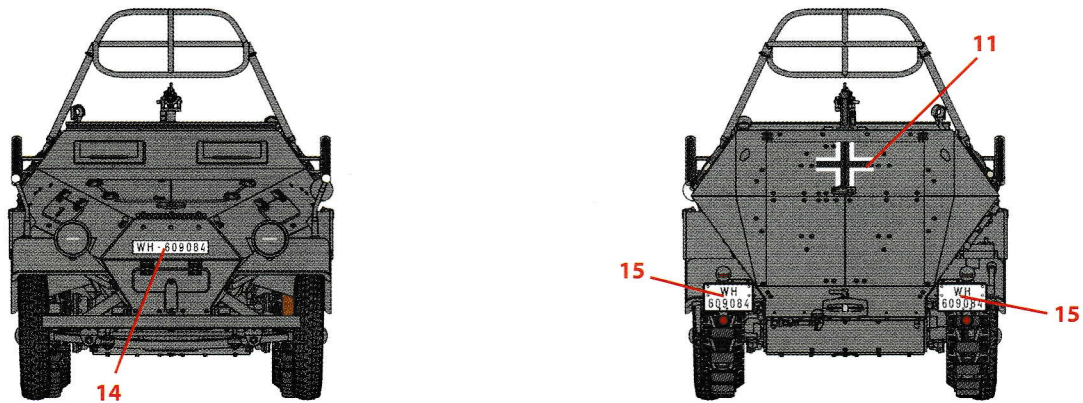

2. Sd.Kfz.251/6 Ausf.A, 1941 г.  
Sd.Kfz.251/6 Ausf.A, 1941

ООО ICM Холдинг  
ул. Бориспольская 9, строение 64,  
02099, Киев, Украина  
Тел./факс: +38(044) 369 54 12  
E-mail: export@icm.com.ua



ICM Holding  
Borispolskaya, 9, build. 64,  
02099, Kiev, Ukraine  
Tel./Fax: +38(044) 369 54 12  
E-mail: export@icm.com.ua