

| | | | | | | | | | |
|---|----------------------|------------|--------------|-------------|------------|------------|------------|----------------|-------------------|
| N | 140 DARK GULL GRAY | GRAU | GRIS | GRIS | GRIS | GRIS | GRIS | GRIS | GRIS |
| M | 117 MEDIUM GREEN | OLIVGRUN | VERDE OLIVA | OLIVGRUEN | ZILVEREN | ZILVER | ARGENT | SILVERGRAN | VERDE OLIVA |
| L | 11 SILVER FOX | PLATA | VERDE OLIVA | OLIVGRUEN | ZILVEREN | ZILVER | ARGENT | SILVERGRAN | VERDE OLIVA |
| K | 130 SATIN WHITE | WEISS | BLANCO | BLANCO | WIT | WIT | BLANC | BLANC | BLANC |
| J | 127 LIGHT GRAY | HELLGRAU | GRIS CLARO | GRIS CLARO | LICHT GRIS | LICHT GRIS | GRIS CLAIR | LUSGRA | GRIGIO CHIARO |
| H | 147 LIGHT GHOST GRAY | HELLGRAU | GRIS CLARO | GRIS CLARO | LICHT GRIS | LICHT GRIS | GRIS CLAIR | LUSGRA | GRIGIO CHIARO |
| G | 145 MEDIUM GRAY | GRAU | GRIS | GRIS | GRIS | GRIS | GRIS | GRIS | GRIGIO |
| F | 155 OLIVE DRAB | OLIVGRUN | ACETUNGRUN | OLIVGRUEN | OLIVGRUEN | OLIVGRUEN | OLIVGRUEN | OLIVGRUEN | VERDE OLIVA SCURO |
| E | 53 GUMMETAL | METALLIC | METALLIC | METALLIC | METALLIC | METALLIC | METALLIC | METALLIC | METALLIC |
| D | 148 BADOOME TAN | GELBBRAUN | CANELA | OKER | BRUN CLAIR | BRUN CLAIR | GULBRUN | MARBRON CHIARO | METALLIC |
| C | 3 BRUNSWICK GREEN | DUNKELGRUN | VERDE OSCURO | DONKERGRUEN | VERT FONCE | VERT FONCE | MOKKGRON | VERDE SCURO | METALLIC |
| B | 154 INDIANIA YELLOW | GELB | AMARILLO | GELB | JAUNE | JAUNE | GUL | GIALLO | METALLIC |
| A | 33 FLAT BLACK | SCHWARZ | NEGRO | ZWART | NOIR | NOIR | SVART | NERO | METALLIC |

The numerical color code listed below indicates the correct Monogram-Humrol color selections that you will need to detail your kit. These paints are specially formulated for application to plastic surfaces and are available at your favorite hobby retailer.

READ THIS BEFORE YOU BEGIN

- Study the assembly drawings.
- Each plastic part is identified by a number.
- Check the fit of each piece before cementing in place.
- Do not use too much cement to join parts.
- Use only cement for polystyrene plastic.
- Model may be painted to match photos on box.
- Allow paint to dry thoroughly before handling parts.
- Scrape paint from areas to be cemented.
- For better paint and decal adhesion, wash the plastic parts in a mild detergent solution. Rinse and let air dry.

ALGEMEINE HINWEISE

- Die Anordnung der Bauteile ist aus den Zeichnungen der Anleitung ersichtlich.
- Jedes Bauteil ist durch eine Nummer gekennzeichnet.
- Die Teile vor dem Verkleben ungeeignet zusammenhalten, um ihren Passsitz zu prüfen.
- Nur Modellbaukleber für Polystyrol verwenden.
- Man kann das Modell nach den Fotos auf der schachtel anstreichen.
- Bemaßte Teile vor der Weiterverwendung gut trocknen lassen.
- Die Farbe muss von allen späteren Klebestellen abgeschabt werden.
- Damit die Farbe und die Abziehbilder besser kleben, sind die Plastikteile in einer milden Seifenlauge zu waschen. Dann abspülen und an der Luft trocknen lassen.

LEA ESTO ANTES DE EMPESAR

- Estudie los dibujos de ensamblaje.
- Cada pieza de plástico se identifica por un número.
- Verifique que cada pieza encaje bien antes de pegar en posición.
- No use demasiada pegamento para unir las piezas.
- Use únicamente pegamento para plástico de poliestirena.
- El modelo puede pintarse de acuerdo con las fotografías de la caja.
- Permita que se seque la pintura completamente antes de tocar las piezas.
- Raspe la pintura de las superficies que serán pegadas.
- Para una mejor fijación de la pintura y de las calcamánias, lávese las piezas plásticas en una solución de detergente suave. Enjuáguese y déjese secar al aire.

LEES DIT ALVORENS TE BEGINNEN

- Bestudeer de bouwtekening.
- Elk plastic onderdeel is genummerd.
- Controleer de passing van elk deel vóór het lijmen.
- Gebruik niet te veel lijm.
- Alleen lijm voor polystyreen plastic gebruiken.

DA LEGGERE PRIMA DI INIZIARE

- Studia le illustrazioni.
- Ogni pezzo è identificato da un numero.
- Controlla l'incastro di ogni pezzo prima di incollarlo.
- Non usare troppa colla per unire i pezzi.
- Adopera solamente colla per materiale plastico.
- Il modello si può dipingere seguendo le fotografie sulla scatola.
- Aspetta che la vernice sia completamente asciutta prima di maneggiare le parti.
- Asporta la vernice dai punti dove applicherai la colla.
- Per una migliore aderenza di vernice e decalcomanie, lavare le parti in plastica in soluzione detergente non abrasiva. Risciacquare e lasciar asciugare all'aria.

LAS DET HAR INNAN DU BORJAR BYGA

- Studera monteringskisserna.
- Alla plastdelar har identifikationsnummer.
- Kolla noga att delarna passar före limningen.
- Stryk inte för mycket lijm på delarna.
- Använd endast lijm för polystyren-plast.
- Modellen kan målas enligt fotona på kantongen.
- Låt färgen torka ordentligt före limningen.
- Skrapa bort färgen på de ytor som ska limas.
- För bättre vidhäftning av färg och decalcomaner rengör plastdelarna i en mild tvättmedelslösning. Skölj och låt lufttorka.

LE MONTAGE

LISEZ CE QUI SUIT AVANT DE COMMENCER

- Etudiez les schémas d'assemblage.
- Chaque pièce plastique porte un numéro d'identification.
- Vérifiez que chaque pièce soit bien conforme avant de la coller à sa place.
- N'utilisez pas trop de colle pour réunir les pièces.
- Utilisez uniquement une colle spéciale pour polystyrène sur la boîte.
- Le modèle peut être peint conformément aux photos.
- Laissez sécher la peinture complètement, avant de manipuler les pièces.
- Grattez la peinture sur les surfaces devant être collées.
- Pour assurer la meilleure adhésion possible de la peinture et des decalcomanies, laver les pièces de plastique avec une légère solution savonneuse. Rinses et laissez sécher à l'air.



ACKNOWLEDGEMENT - THIS ACCURATELY DETAILED MODEL WAS DESIGNED FROM AUTHENTIC DRAWINGS AND PHOTOGRAPHS. TECHNICAL INFORMATION WAS SUPPLIED BY McDONNELL DOUGLAS CORPORATION, ST. LOUIS, MISSOURI.

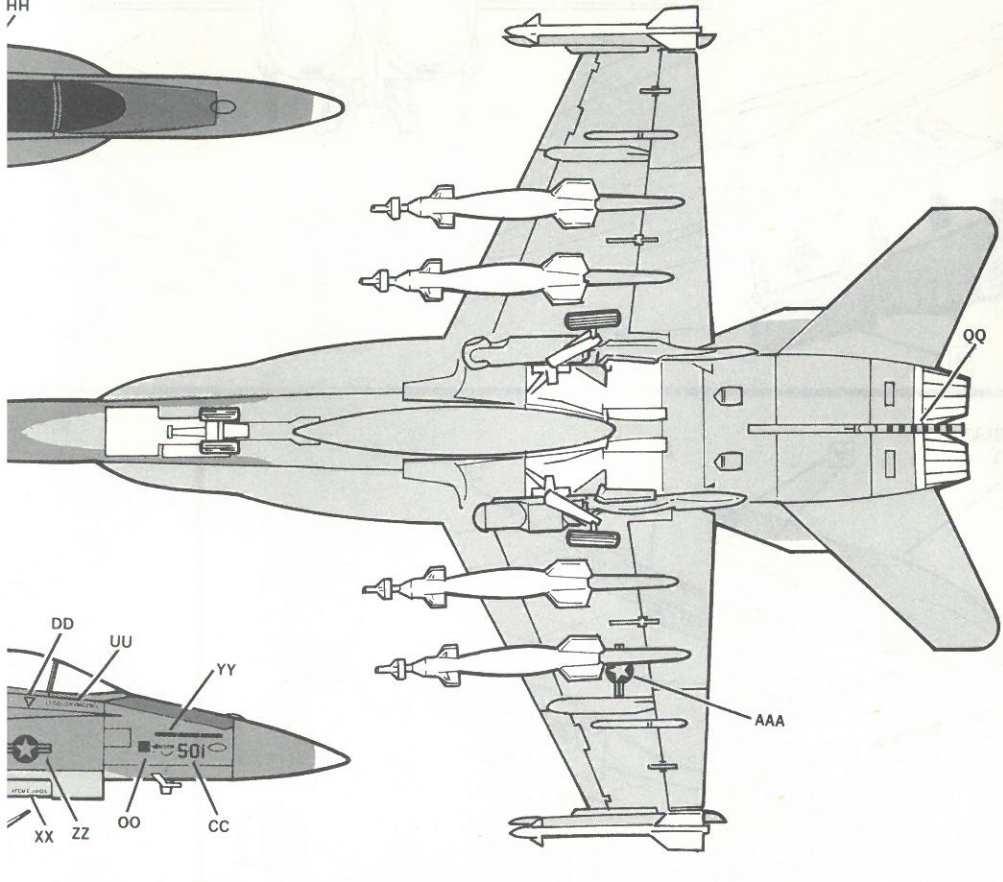
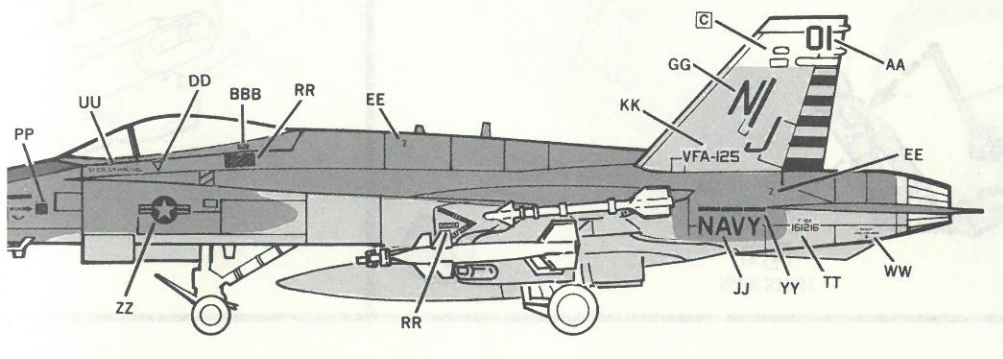

A-18 STRIKE FIGHTER

MONOGRAM KIT 5807 1/48 SCALE MASSTAB 1:48 ESCALA 1/48 SCHAAL 1:48 1/48 ECHELLE SKALA 1/48 SCALA 1/48

MONOGRAM MODELS, INC. Morton Grove, Ill. Copyright © 1980 & 1983. All rights reserved. Made in U.S.A. 5807-0201

The supersonic F/A-18 Hornet is a multi-purpose aircraft designed for the United States Navy and Marine Corps. This sophisticated aircraft will form the backbone of Navy and Marine fighter and attack squadrons for years to come. As an air superiority aircraft, the Hornet is equipped with an advanced radar system, Sparrow and Sidewinder air-to-air missiles, and a 20 mm cannon that provides a lethal defense against airborne adversaries. The A-18 is an all-weather design that can also be configured to perform as an attack aircraft. Equipped with external pylons, the A-18 can carry a wide array of conventional munitions. This dual-purpose design will provide combat commanders with the flexibility to configure aircraft to match a given combat objective.

The Hornet was co-developed by Northrop and McDonnell Douglas as an outgrowth of the YF-17 program. The aircraft is 56 feet long and has a wingspan of 40.4 feet. The sleek fuselage employs an unusual leading edge extension that permits the aircraft to fly at angles of attack in excess of 60 degrees. The powerful General Electric F404 engines are in the same thrust class as the venerable J-79, yet they achieve this power with eight fewer compressor stages and 40% fewer internal parts. An advanced Hughes APG-65 radar system utilizes advanced digital technology to locate enemy targets. The cockpit utilizes a sophisticated head-up display to convey vital flight information to the pilot.

The Hornet represents a major advance in aircraft technology. Reliability, maintainability, and survivability are primary design factors that will contribute markedly to the lifespan of the new Hornet.

Decals provided with your model are for an F/A-18 assigned to VFA-125, the Operational Test and Evaluation Squadron based at Pt. Mugu, California.



OPTIONAL: CLEAN OUT HOLES FOR TANK IN STEP 17
 - WAHLWEISE: DIE LÖCHER SIND FÜR DEN TANK IN STEP 17
 STUFE 17 AUSZUSCHNEIDEN
 - OPCIONAL: LIMPIENSE LOS AGUJEROS PARA EL TANQUE EN EL PASO 17
 - FACULTATIF: NETTOYER LES ORIFICES POUR LE RESERVOIR A L'ETAPE 17
 - VALFRITT: KLIPP UT HÅLEN FÖR SERBATOIO AL PUNTO 17
 - FACULTATIVO: RIPULIRE FORI PER SERBATOIO AL PUNTO 17

OPTIONAL: CLEAN OUT HOLES FOR MOUNTS 47 IN STEP 19
 - WAHLWEISE: DIE LÖCHER SIND FÜR DIE STÜTZEN 47 IN STUFE 19 AUSZUSCHNEIDEN
 - OPCIONAL: LIMPIENSE LOS AGUJEROS PARA LOS SOPORTES 47 EN EL PASO 19
 - FACULTATIF: NETTOYER LES ORIFICES POUR LES MONTAGES 47 A L'ETAPE 19
 - VALFRITT: KLIPP UT HÅLEN FÖR SÖSTEGNI 47 AL PUNTO 19
 - FACULTATIVO: RIPULIRE FORI PER SOSTEGNI 47 AL PUNTO 19

OPTIONAL: CLEAN OUT HOLES FOR TANK IN STEP 17
 - WAHLWEISE: DIE LÖCHER SIND FÜR DEN TANK IN STEP 17
 STUFE 17 AUSZUSCHNEIDEN
 - OPCIONAL: LIMPIENSE LOS AGUJEROS PARA EL TANQUE EN EL PASO 17
 - FACULTATIF: NETTOYER LES ORIFICES POUR LE RESERVOIR A L'ETAPE 17
 - VALFRITT: KLIPP UT HÅLEN FÖR SERBATOIO AL PUNTO 17
 - FACULTATIVO: RIPULIRE FORI PER SERBATOIO AL PUNTO 17

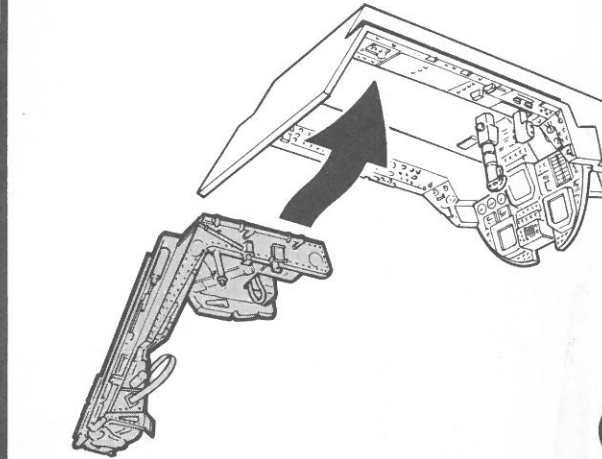
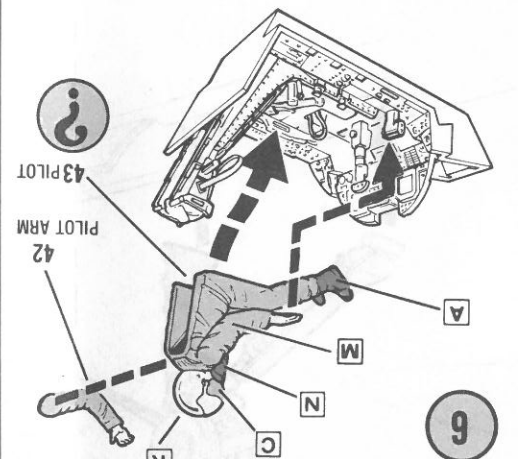
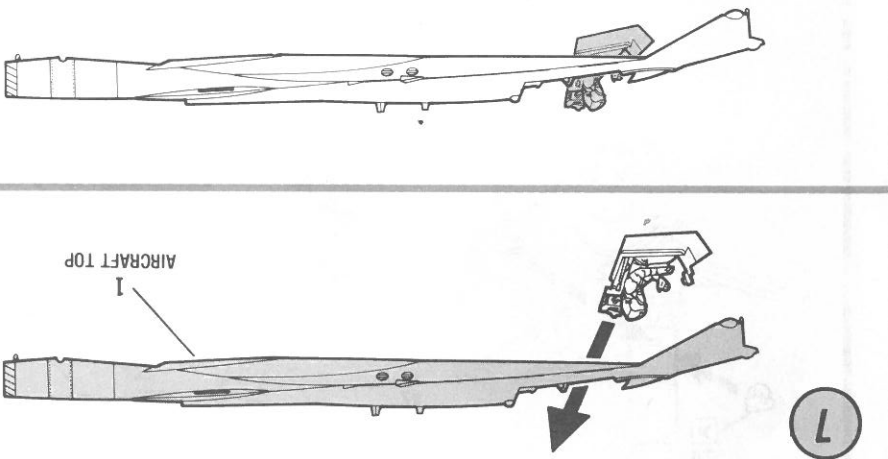
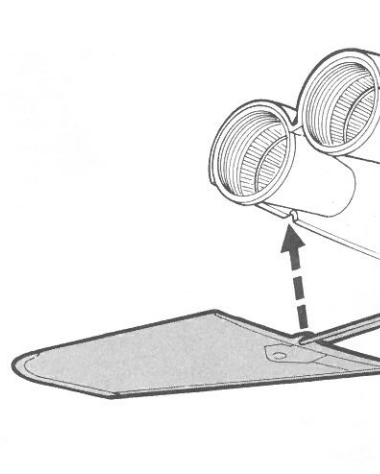

SHOULDER HARNESS
 TEMPLATE
 CUT OUT STRAP FOR SEAT ASSEMBLY
 - DER RIEMEN IST ZUM ZUSAMMENBAU DES SITZES ANZUSCHNEIDEN
 - RECORTAR EL CINTURON PARA EL ARMADO DEL ASIENTO
 - KNIP UIT RIEM VOOR MONTAGE VAN ZITPLAATS DECOUPER LA CEINTURE POUR LE MONTAGE DU SIEGE
 - KLIPP UT SÄKERHETSÅLÅTE FÖR SITSMONTERINGEN
 - RITAGLIARE CINTURA PER FOR SITSMONTERINGEN
 MONTAGGIO SEDE

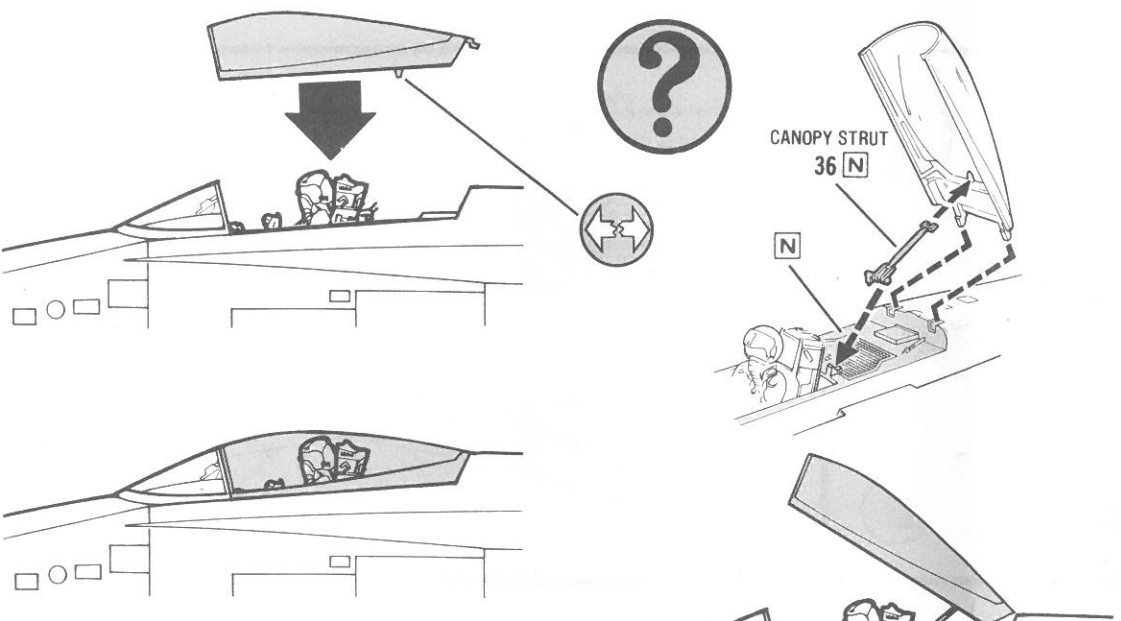
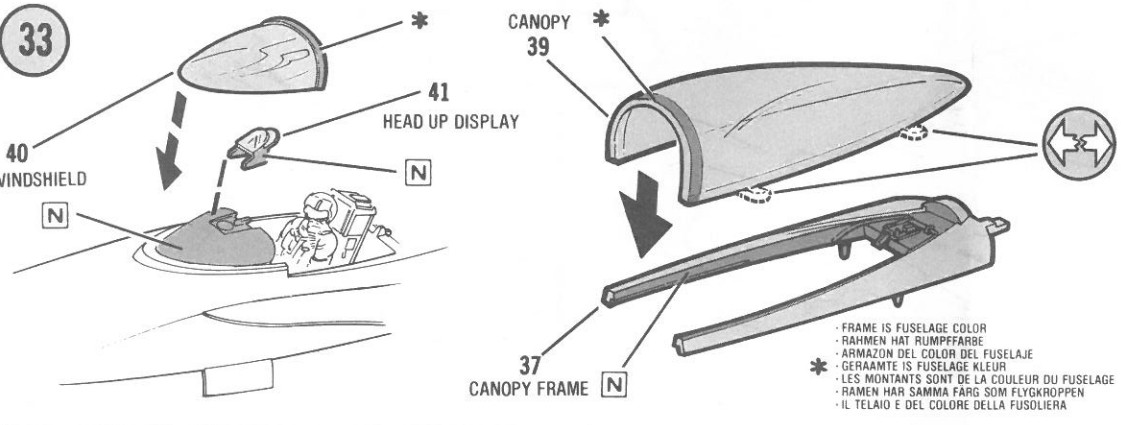
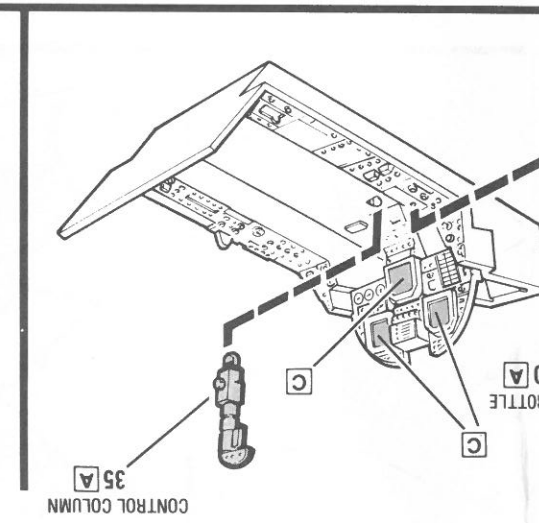
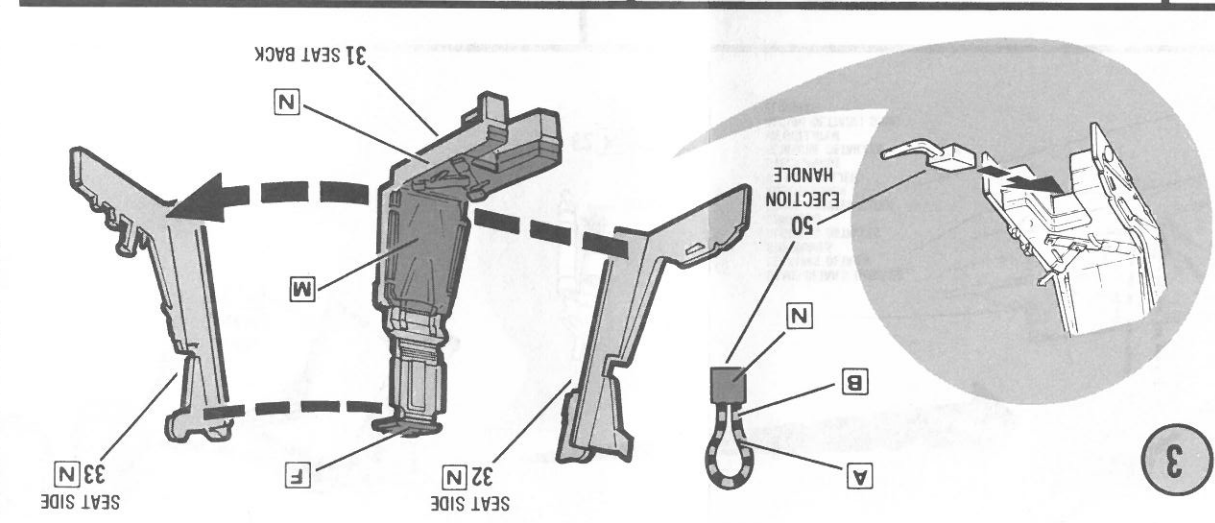

CANOPY DETAIL—MASK ENTIRE CANOPY WITH A DULL FINISH ACETATE MENDING TAPE. CAREFULLY CUT THE TAPE FROM AREAS TO BE PAINTED. PAINT THE EXPOSED PARTS AND ALLOW TO DRY. REMOVE THE REMAINING TAPE.
 FÜR DAS KUPPELDACH—DAS GESAMTE KUPPELDACH MIT MATTEM AZETATKLEBSTREIFEN VERKLEIDEN. DEN KLEBSTREIFEN SORGFÄLTIG VON DEN ZU STREICHENDEN FLÄCHEN ABSCHNEIDEN. DIE FREIEN TEILE STREICHEN UND TROCKNEN LASSEN. DEN ÜBRIGEN KLEBSTREIFEN ENTFERNEN.
 DECORACION DE LA CARLINGA—CUBRIR ENTERAMENTE LA CARLINGA CON LA CINTA DE PEGAR DE COLOR ACETATO APAGADO. RECORTE CUIDADOSAMENTE LA CINTA. DE LAS AREAS A SER PINTADAS. PINTA LAS PARTES QUE QUEDEN EXPUESTAS Y DEJE SECAR. RETIRE LA CINTA DE PEGAR.
 DETAILLE VAN KOEPELDACH—BEDEK DE GEHELE KOEPELDACH MET DOF GLANZENDE ACETATE VERSTEL BAND. KNIP DE BAND MET ZORG UIT VAN DE TE VERVEN OPPERVLAKTEN. VERF DE NIET BEDEKTE DELEN EN LAAT ZE DROGEN. VERWIJDER DE OVERBLIJFENDE BAND.

FINITION DE LA VERRIERE—COUVRIR ENTIEREMENT LA VERRIERE AU MOYEN DE RUBAN ADHESIF D'ACETATE MAT. DEGAGEZ LES ZONES A PEINDRE EN DECOUPANT LE RUBAN AVEC SOIN. PEINDRE LES SURFACES DEGAGEES ET LAISSER SECHER. ENLEVER LE RUBAN RESTANT.
 HUVDEKORERING—MASKERA HELA HUVEN MED EN MATTBEHANDLAD ACETATE LAGNINGSTEJ. SKÅR FÖRSIKTIGT BORT TEJPEN FRÅN OMRADEN SOM SKALL MÅLAS. MÅLA DE FRILAGDA YTORN OCH LÅT TORKA. TA BORT KVARVARANDE TEJ.
 DETTAGLIO CALOTTA—MASCHERARE O'INTERA CALOTTA CON UN NASTRO IN ACETATO A FINITURA OPACA. RITAGLIARE ACCURATAMENTE IL NASTRO DALLE AREE DA DITINGERE. DITINGERE LE PARTI ESPOSTE E LASCIAR ASCIUGARE. TOGLIERE IL NASTRO RIMANENTE.

FEDERAL STANDARD COLOR NUMBERS
 The box top can be used as a guide to paint your model, or you may wish to use the painting information on this page to achieve a more accurate finish. The listed numbers refer to color samples printed in FS 595a. This publication is available from:
 GSA SPECIFICATIONS
 7th & D Streets S.W.
 Room 6039
 Washington, D.C. 20407
 Write to GSA for information regarding current price and availability. Monogram-Humbrol enamels are color matched to duplicate Federal Standards.

| | |
|---|---------|
| G | FS35237 |
| H | FS36375 |
| J | FS36495 |

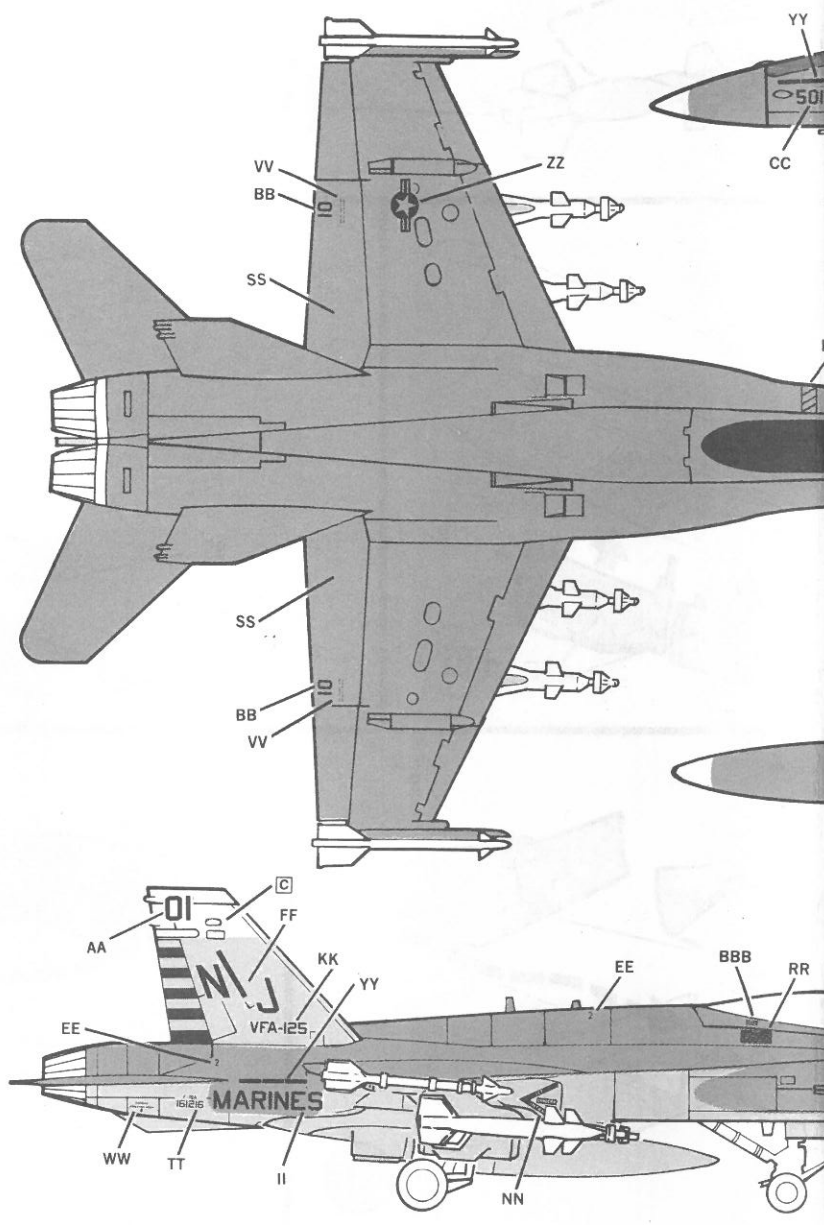

A-18 STRIKE FIGHTER

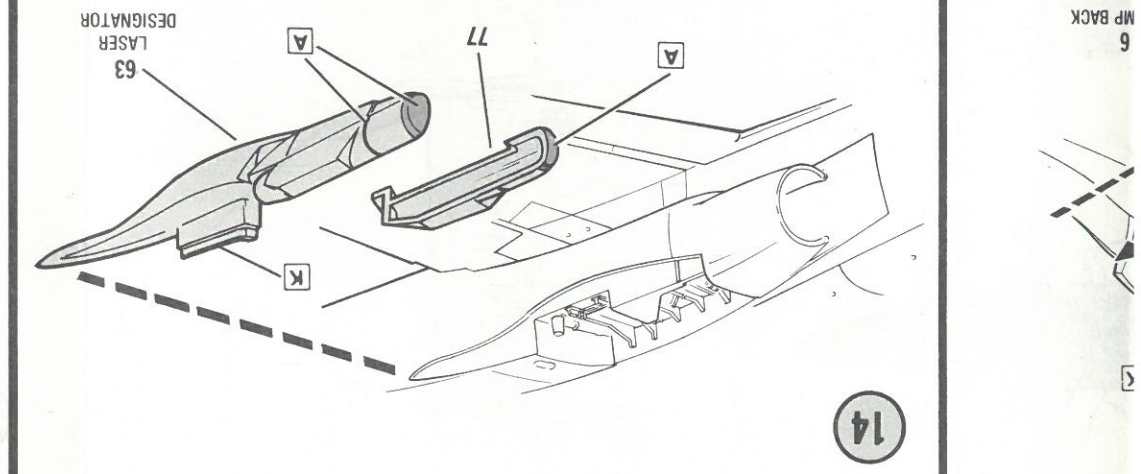
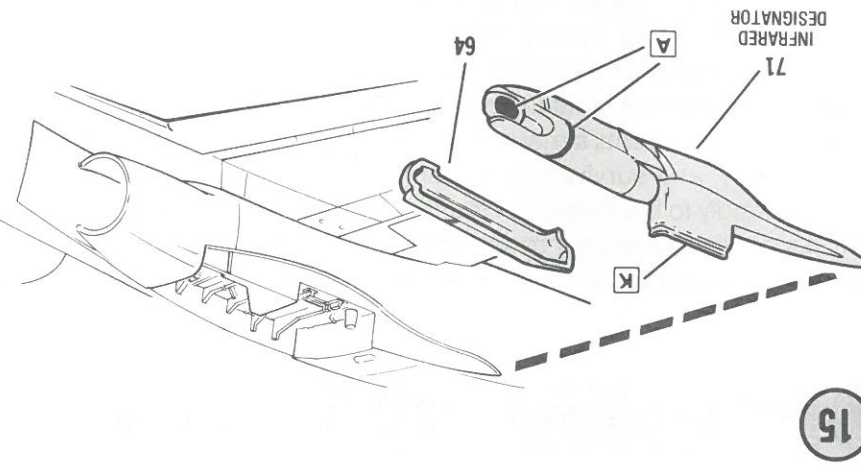
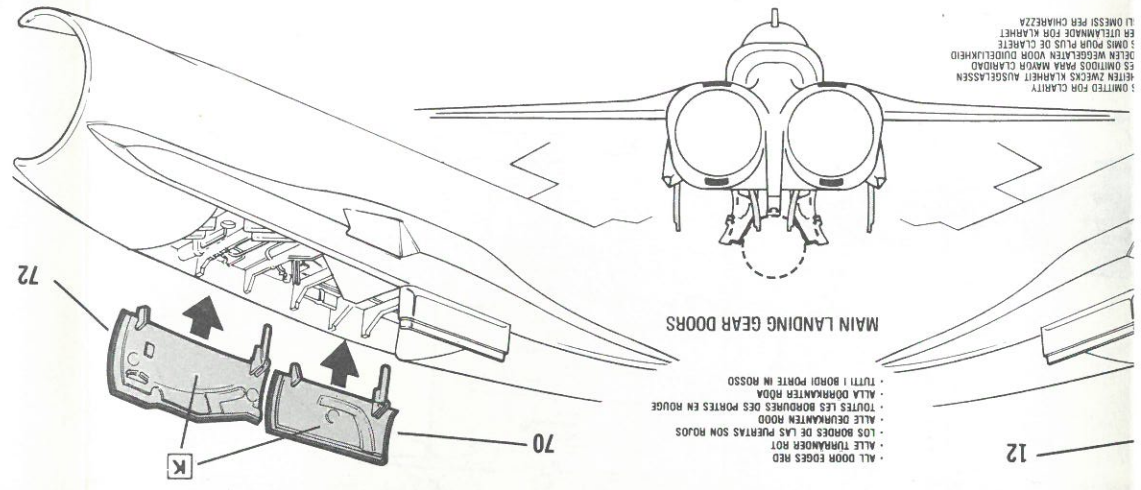
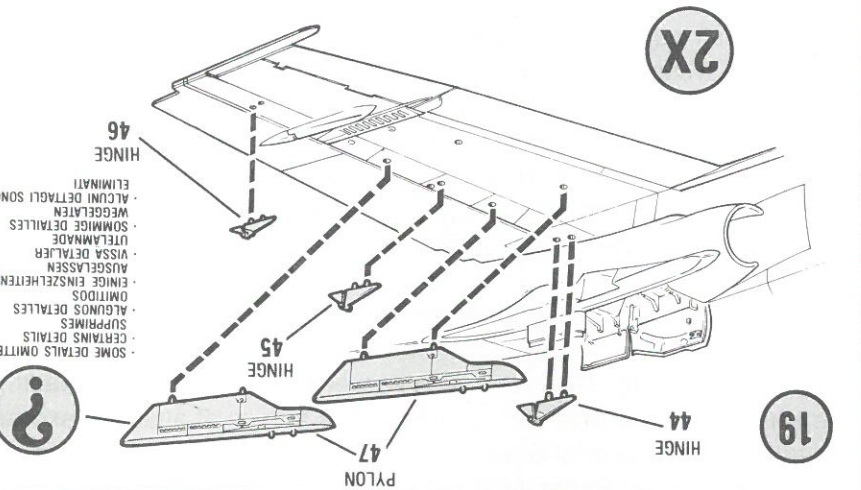
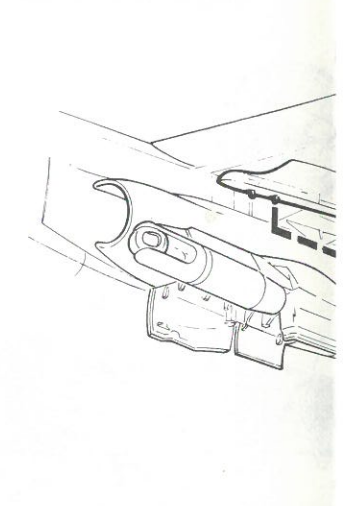
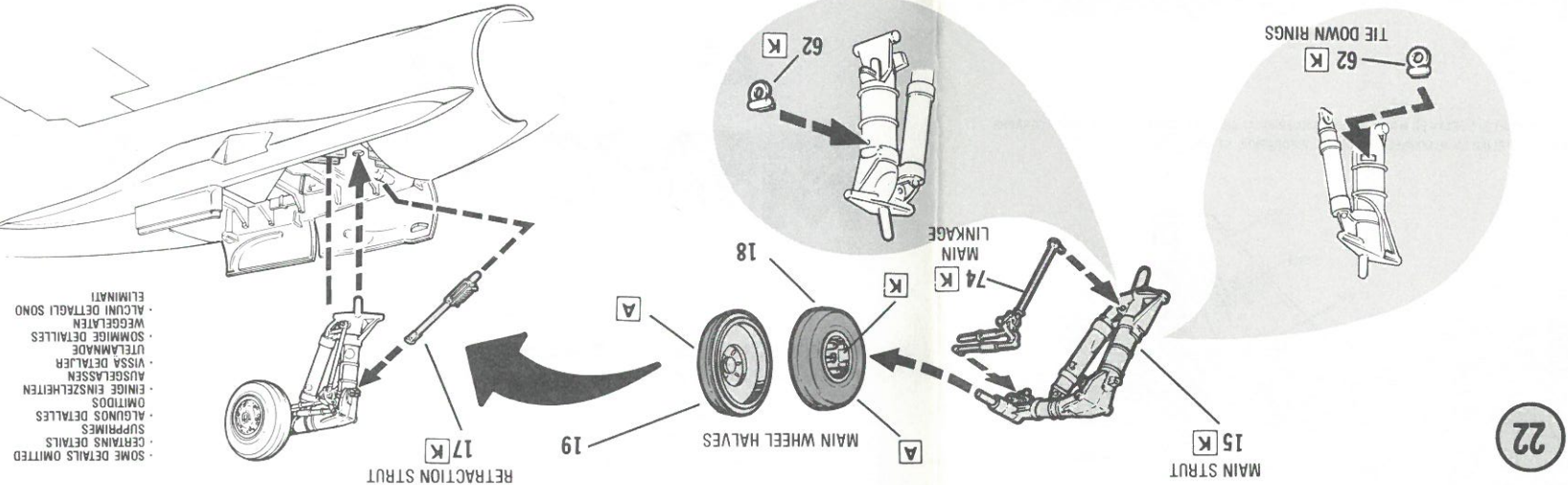
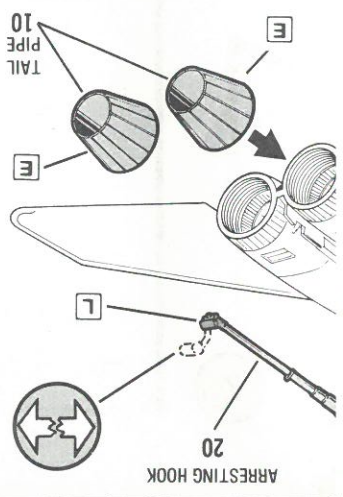
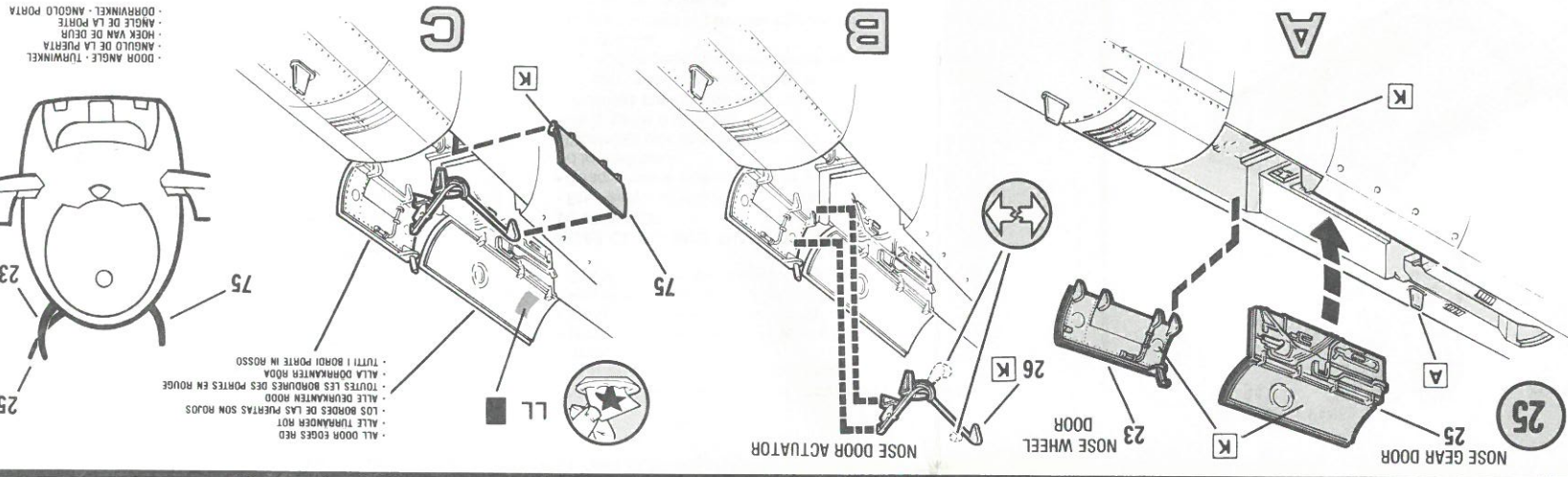
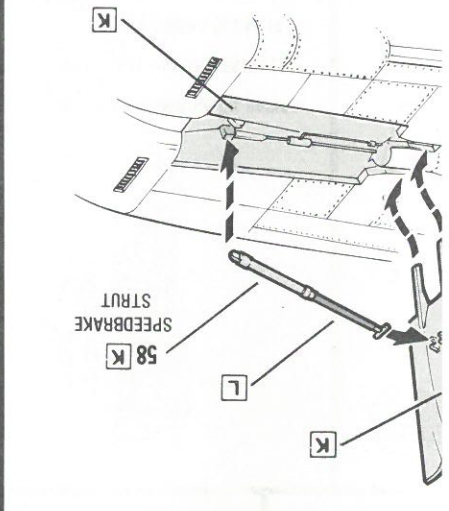
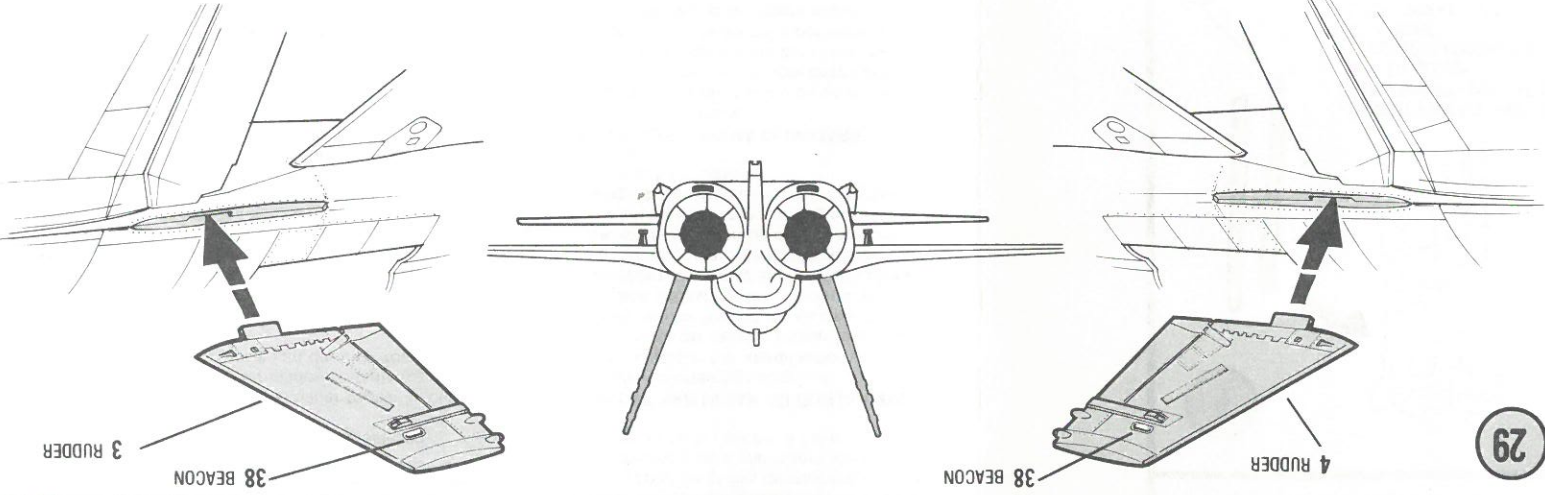
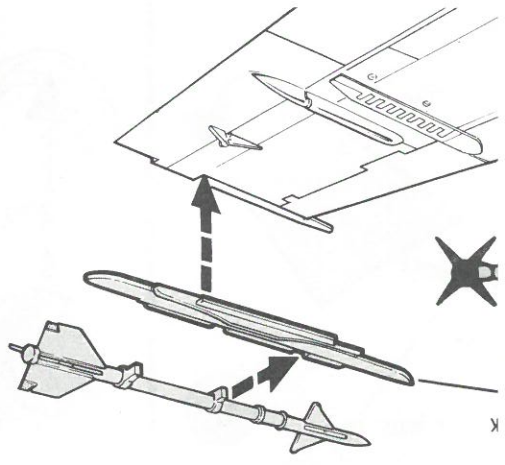
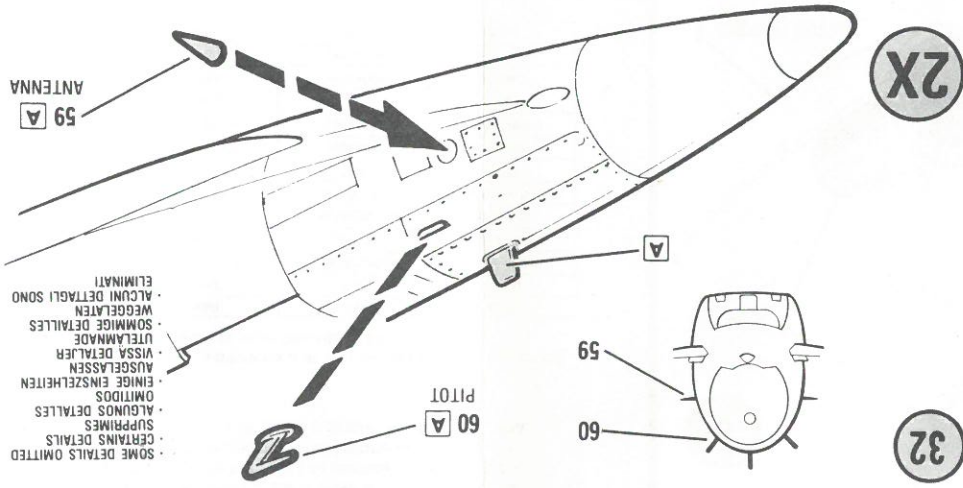

11

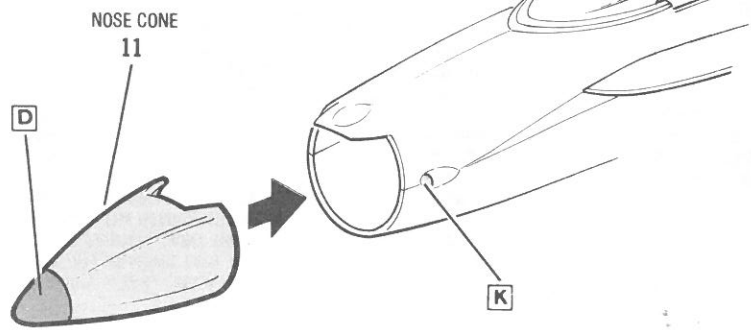

12

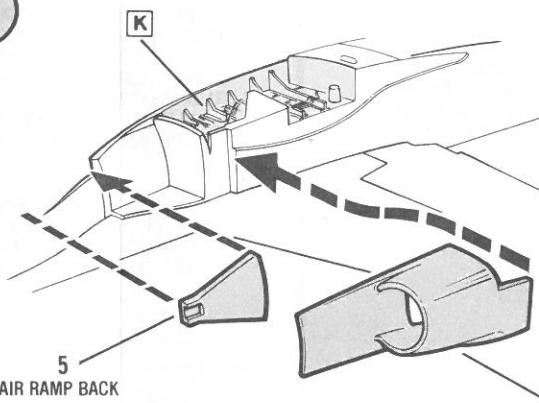

13

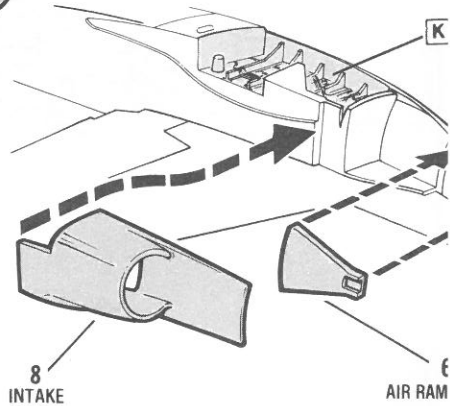

16

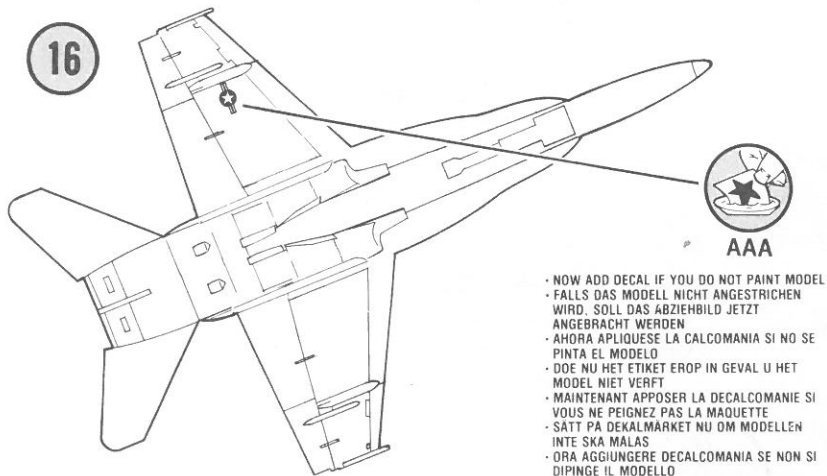

17

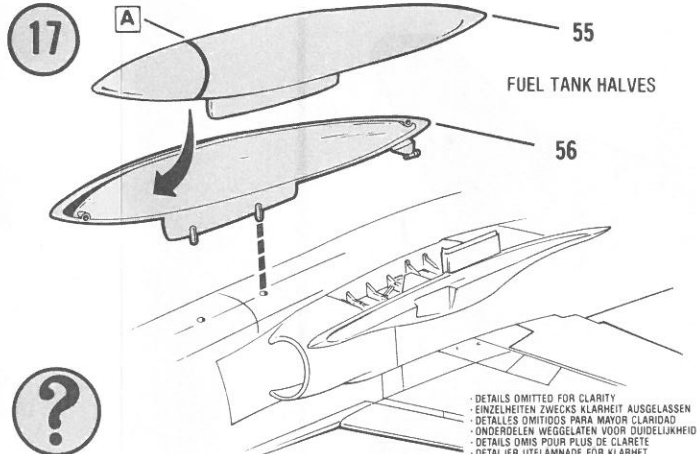

18

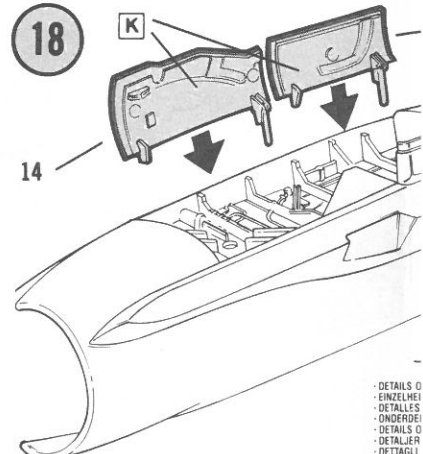

20

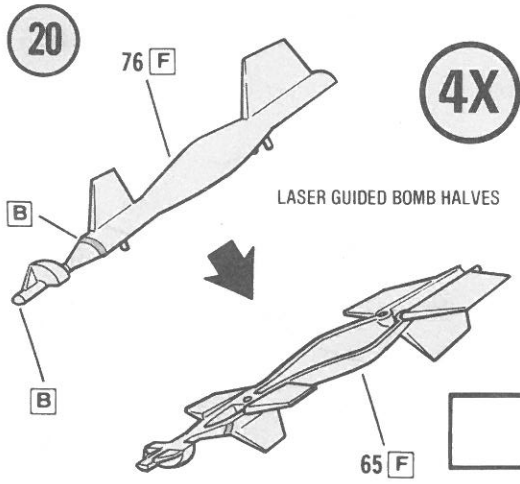

21

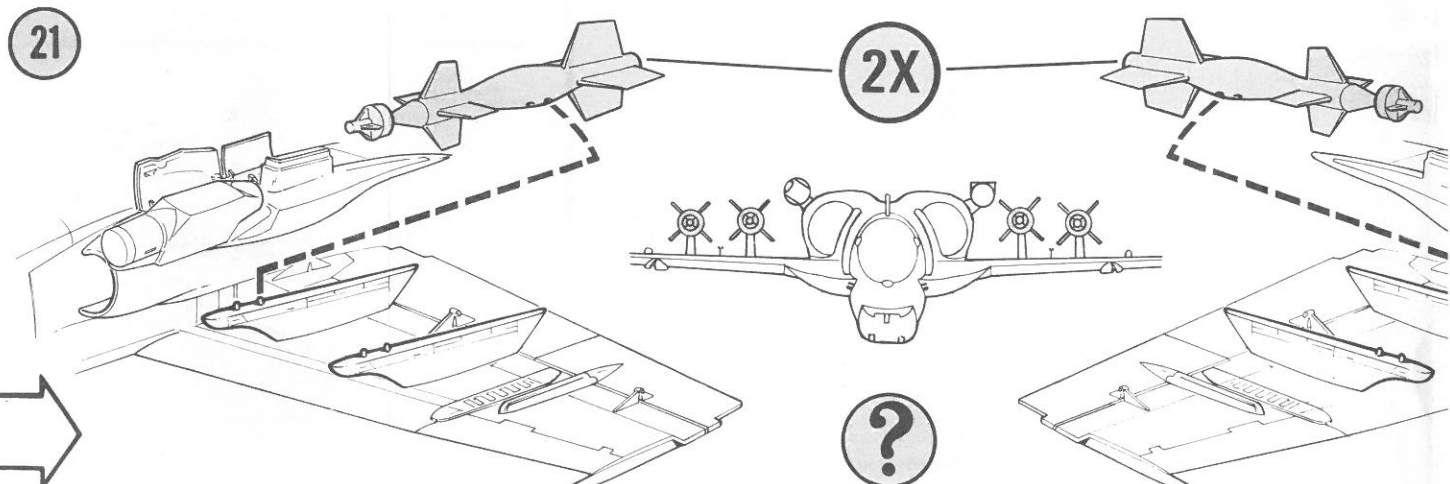

23

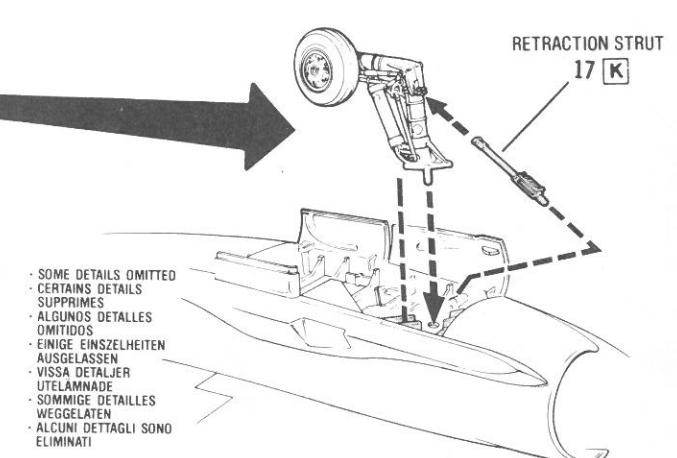
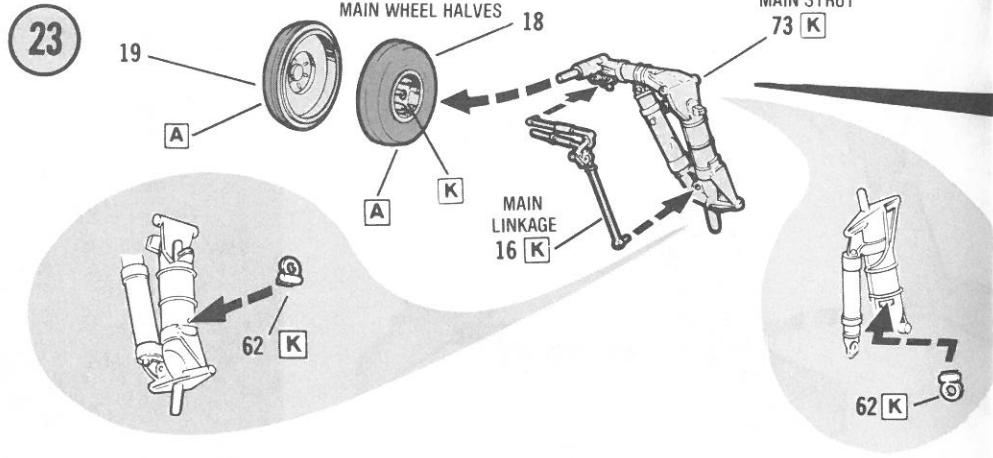

24

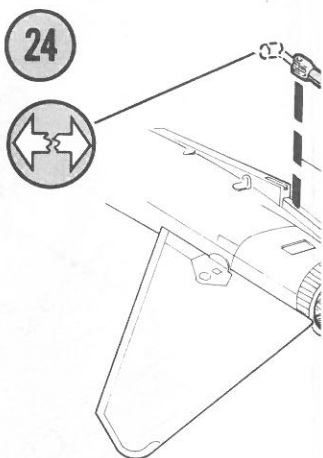

26

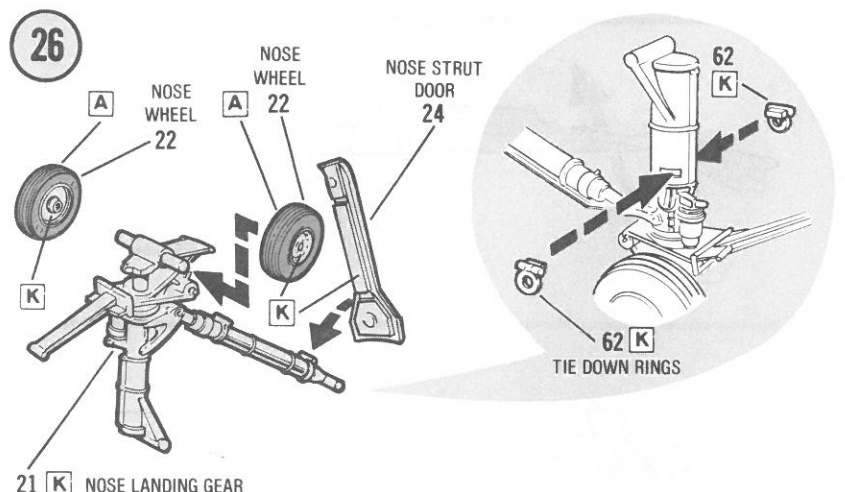

27

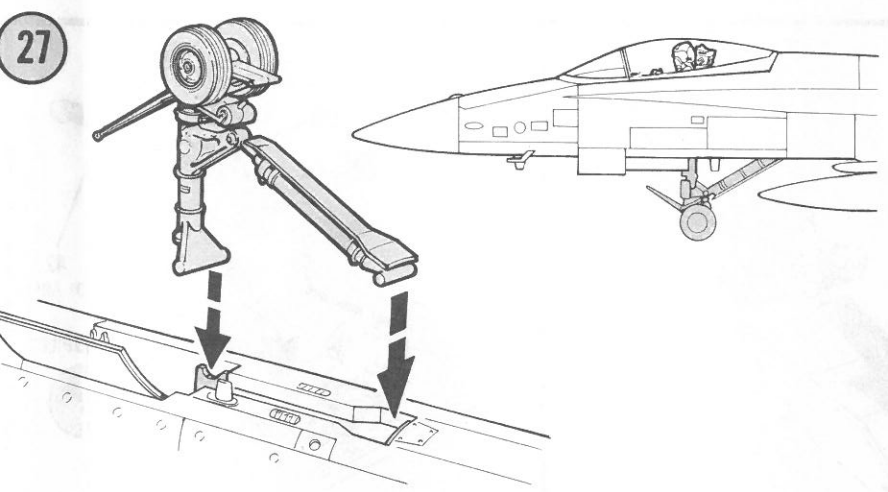

28

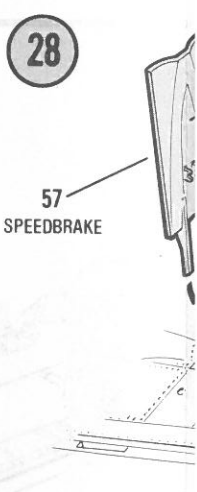

30

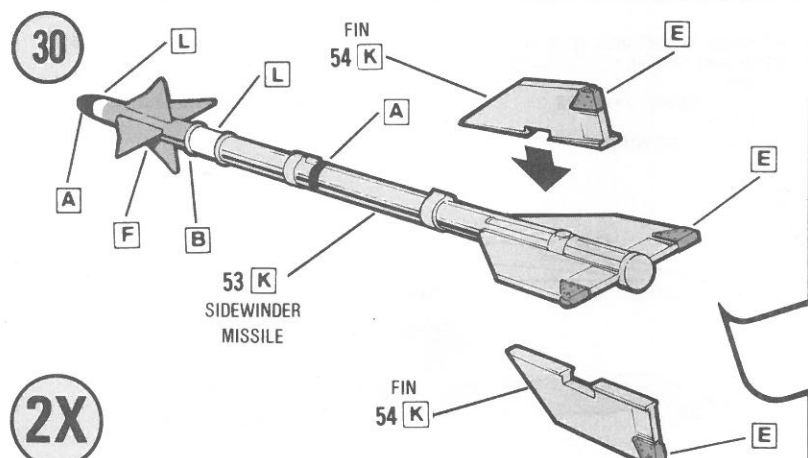

31

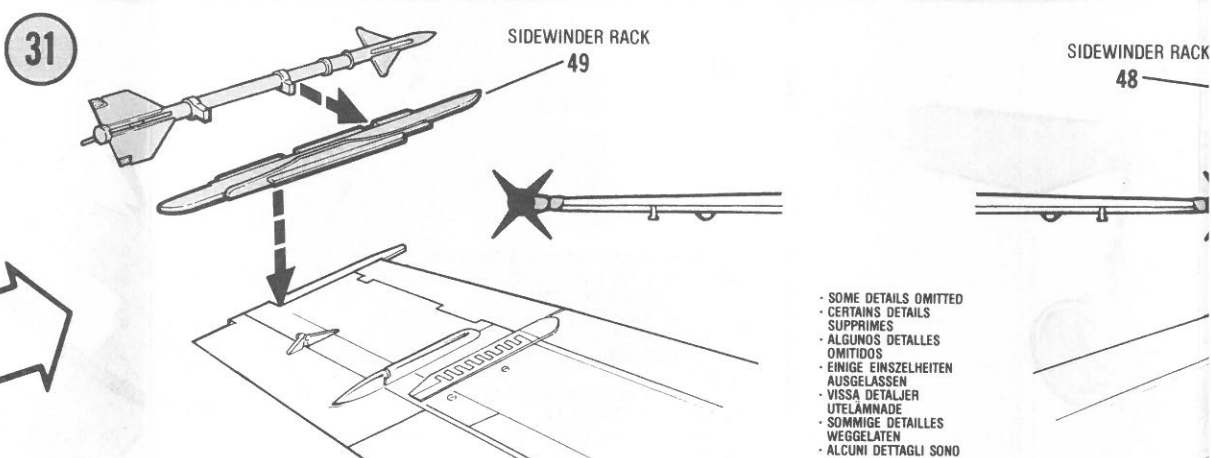



ZZ



AAA

II

MARINES NAVY

JJ

01 AA 01



DD



FF



HH



GG



KK

VFA-125
VFA-125



OO

01 BB 01

2 EE 2
2

XX
AFCME.J.VIGIL

DANGER
ARRESTING HOOK
↓
STEP WITH FLAP
JACK INSTALLED

WW
DANGER
ARRESTING HOOK
↓
STEP WITH FLAP
JACK INSTALLED

VV

F-18A
161216

TT

F-18A
161216

NO STEP NO STEP

SS

BBB



MM

QQ

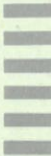

NN

RR

PP

501 CC 501



YY

LT.COL.G.R.VANGYSEL
LT.COL.G.R.VANGYSEL

UU

A-18 HORNET 5807-0300