

124801

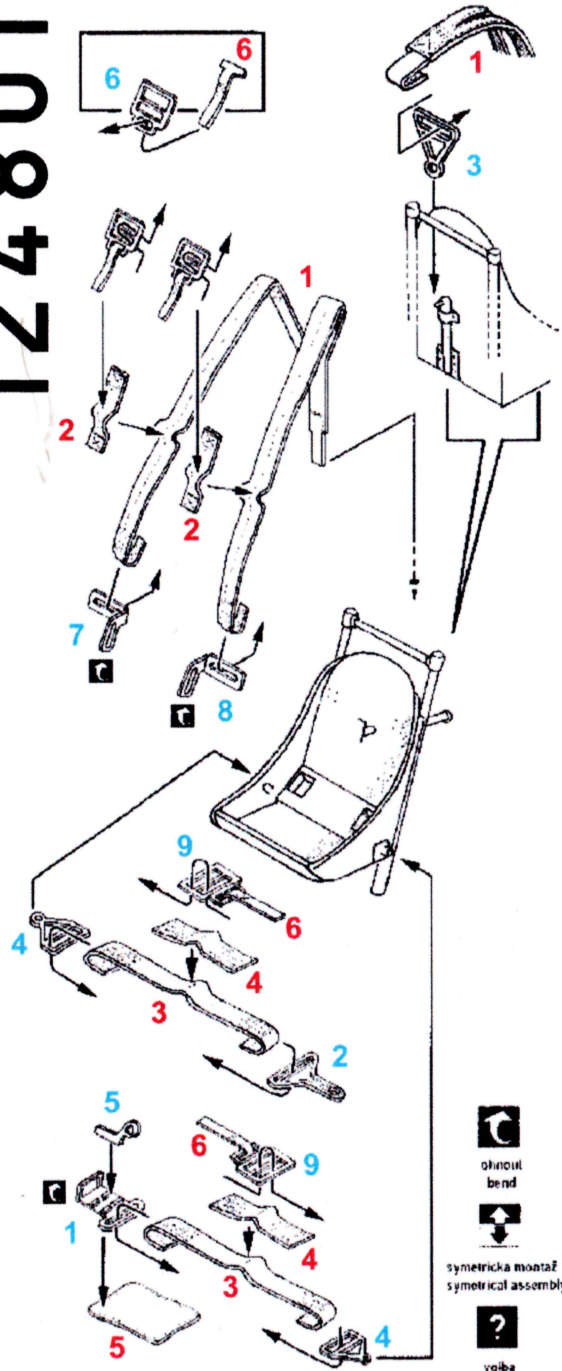

ohnutí bend



symetrická montáž symmetrical assembly



vooba option

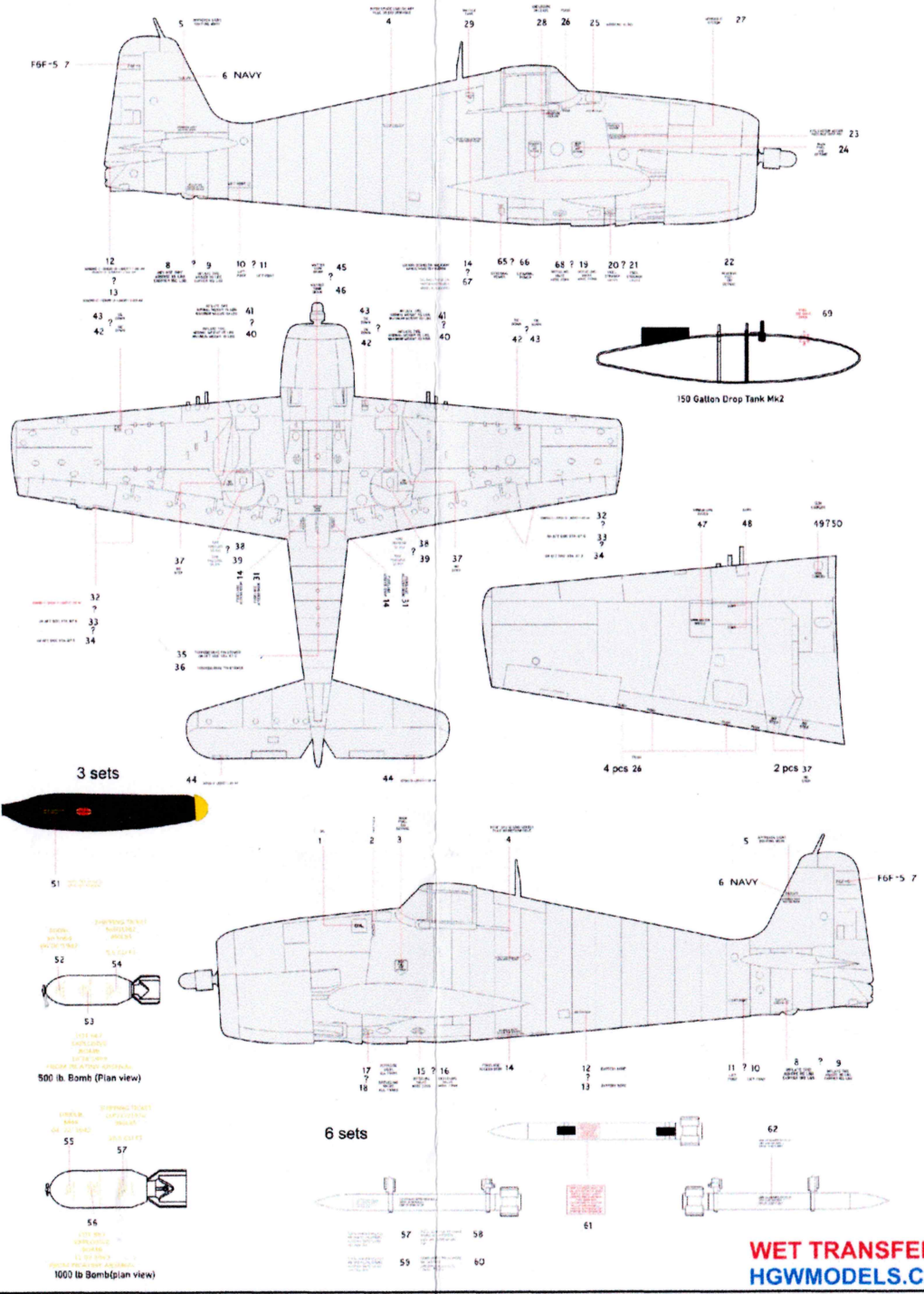



### The preparation of the surface prior to the application of the **HGW Wet Transfer**:

- The HGW Wet Transfer technology has been tested on Gunze brand paints and preparations.
- Carry out the test (not on the model), if you are applying to paint made by a different manufacturer.
- We recommend to spray the surface with a glossy varnish in order to achieve a perfect result.
- No matter whether you are applying the transfer onto paint or varnish, it is advisable to go over the surface using sandpaper of a grade from 6 000 to 8 000.
- Naturally, it is also essential to ensure that the base is clean, grease-free and clear of dust.

### You will need:

- a scalpel,
- sharp tweezers,
- the Mr. Mark Softer / Setter product by Gunze,
- a cotton bud and a clean cloth.

WWW.HGWMODELS.CZ

# WET TRANSFER

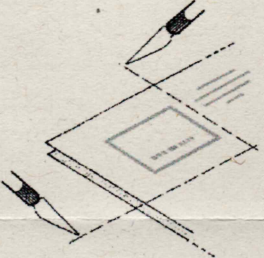
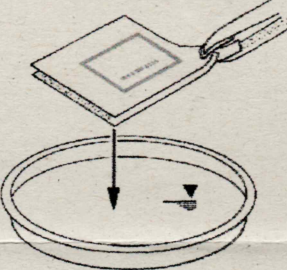
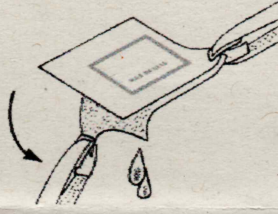
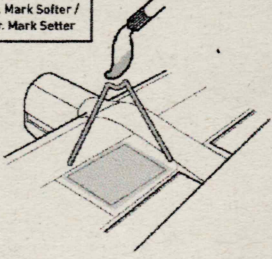
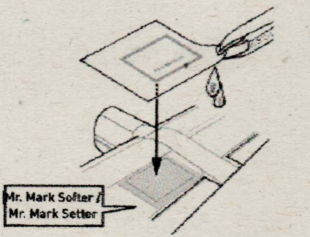
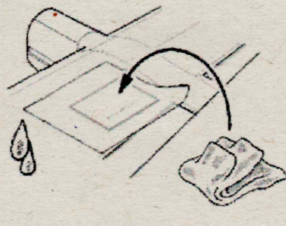
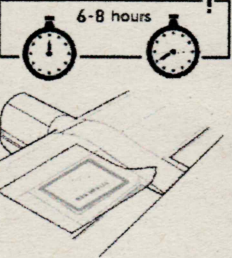
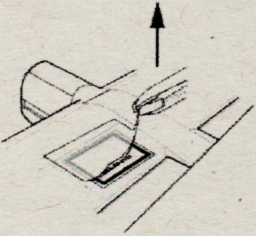
<p>1 Cut out the required design using a sharp scalpel.</p> 	<p>2 Soak the base paper in warm water [approx. 20 sec].</p> 	<p>3 Remove the transfer from the base paper.</p> 
<p>4 Apply a layer of Mr. Mark Softer or Mr. Mark Setter on the surface where you intend to apply the transfer.</p> <p>Mr. Mark Softer / Mr. Mark Setter</p> 	<p>5 Place the transfer in the required position on the layer of Mr. Mark Softer or Mr. Mark Setter.</p> <p>Mr. Mark Softer / Mr. Mark Setter</p> 	<p>6 Carefully press out any excess liquid and bubbles. [Use the cloth and the cotton bud.]</p> 
<p>7 Ideally, leave it to dry for 6-8 hours.</p> <p>6-8 hours</p> 	<p>8 Carefully remove the transparent transfer film.</p> 	<p>9 Clean off any traces of transfer glue with a wet cloth.</p> 