



KIT 2828

85282800200

Shelby Cobra 427 S/C™

There are fast cars, and then there are ridiculously fast cars. The kind of vehicle that legends are made of. The Shelby Cobra 427 S/C™ is one of those cars.

Carroll Shelby had an illustrious, but short career as a race car driver. Named Driver of the Year for 1957 by a major sports magazine, Shelby was forced to retire early due to heart problems. What might be seen as a setback for some, Shelby saw as an opportunity as he could now pursue a long-time goal—designing and bringing to market a world-class sports car. The car we now know as the Shelby Cobra began life as the British made two-seater AC Ace. The Ace was ideal for Shelby as the car was small and light, with an aluminum body and good handling characteristics. The other piece of the puzzle came from Ford, who had just released a new, small V8 engine for the mid-size Fairlane line. After importing a car from AC and obtaining a few engines from Ford, Shelby and a friend had the engine, a high-performance version of the new 260 V8, in the car in less than eight hours. The resulting car astounded even Shelby. At barely over a ton in weight it was blindingly fast.

Just as Ford did with its Mustang, the 260 V8 was soon shelved in favor of the high-performance 289.

Never one to leave a car as just "fast", Shelby wanted more. The answer came in the form of Ford's monster 427 cubic inch V8. As great a performer as the Cobra 289 was, the 427 picked that up ten notches. 0-60 mph came in under four seconds. Forty years later, one would be hard pressed to find a car today at any price that can match that. As in many muscle cars of the era, putting a heavy, large V8 into a smaller car often helped it go fast in a straight line, but penalized it in handling due to the weight of the engine up front. One of the Cobra's strengths was the fact that the engine was set far back from the front of the car. This allowed it to retain a nearly neutral front/rear weight distribution, which helped the Cobra handle well on the track. In fact, the 427 won the SCCA A/Production road racing class in 1965, '66, '67, '68 and '73. We've included decals for you to build an authentic replica of the car that won the '65 championship, Hal Keck's #11, as well as Sam Feinstein's championship winning ride from 1973.



* REPEAT SEVERAL TIMES
* A REPETER PLUSIEURS FOIS



* OPTIONAL PARTS
* PIECES EN OPTION



* DECAL
* DECAL COMANIE



* ALTERNATIVE ASSEMBLY
* ENSEMBLAGE ALTERNATIVE



* CEMENT TOGETHER
* A COLLER



* REMOVE AND THROW AWAY
* A RETIRER ET JETER



* DO NOT CEMENT
* NE PAS COLLER

READ THIS BEFORE YOU BEGIN

- * Study the assembly drawings.
- * Each plastic part is identified by a number.
- * In the assembly drawings, some parts will be marked by a star (★) to indicate chrome plated plastic.
- * For better paint and decal adhesion, wash the plastic parts in a mild detergent solution. Rinse and let air dry.
- * Check the fit of each piece before cementing in place.
- * Use only cement for polystyrene plastic.
- * Scrape plating and paint from areas to be cemented.
- * Allow paint to dry thoroughly before handling parts.
- * Any unused parts may be discarded.

DECAL APPLICATION INSTRUCTIONS

1. Cut desired decal from sheet.
2. Dip decal in water for a few seconds.
3. Place wet decal on paper towel.
4. Wait until decal is movable on paper backing.
5. Place decal in position on model, face up and slide backing away.
6. Press out air bubbles with a soft damp cloth.
7. Milkiness that may appear is for better decal adhesion and will dry clear. Wipe away any excess adhesive.
8. Do not touch decal until fully dry.
9. Allow the decals 48 hours to dry before applying clear coat.

NOTE: Decals are compatible with setting solutions or solvents.

LIRE CE QUI SUIT AVANT DE COMMENCER

- * Etudier les schémas de montage.
- * Chaque pièce en plastique est identifiée par un numéro.
- * Sur les schémas de montage, certaines pièces sont marquées d'une étoile (★) pour indiquer qu'elles sont en plastique chromé.
- * Pour une meilleure prise de la peinture et des autocollants, laver les pièces en plastique avec une solution détergente peu concentrée. Les rincer et les laisser sécher à l'air.
- * Vérifier que chaque pièce s'ajuste bien avant de la coller en place.
- * N'utiliser que de la colle pour polystyrène.
- * Gratter les parties à coller pour enlever le chrome et la peinture.
- * Laisser la peinture bien sécher avant de manipuler les pièces.
- * Toute pièce inutilisée peut être jetée.

DIRECTIVES D'APPLICATION DES AUTOCOLLANTS

1. Découper l'autocollant désiré de la feuille.
2. Tremper l'autocollant dans de l'eau pendant quelques secondes.
3. Placer l'autocollant mouillé sur une serviette en papier.
4. Attendez que l'autocollant puisse être déplacé sur son support en papier.
5. Mettre l'autocollant en position sur le modèle face sur le dessus et faire glisser le support pour l'enlever.
6. Appuyer avec un chiffon doux humide pour éliminer les bulles d'air.
7. La substance laiteuse qui peut apparaître est destinée à améliorer l'adhésion de l'autocollant et devient incolore au séchage. Essuyer pour enlever tout excédent d'adhésif.
8. Ne pas toucher l'autocollant tant qu'il n'est pas bien sec.
9. Laisser l'autocollant sécher pendant 48 heures avant d'appliquer une couche transparente.

REMARQUE: Les autocollants sont compatibles avec les solutions de fixation ou les solvants.

This paint guide is provided to complete this kit as shown on the box.

Ce guide de peinture est fourni pour reproduire le modèle réduit qui apparaît sur la boîte.

Aluminum	Aluminium
Burnt Iron	Fer brûlé
Dark Green Metallic	Gris foncé métallisé
Flat Black	Noir mat
Flat Brown	Brun mat
Gloss Black	Noir brillant
Gloss Red	Rouge brillant
Gold	Or
Guardsmen Blue	Bleu soldat
Gunmetal	Bronze
Semigloss Black	Noir satiné
Silver	Argent
Steel	Acier
Turn Signal Amber	Feu clignotant de direction ambre

If you have any questions or comments, call our hotline at: **(800) 833-3570** or, please write to:

Revell-Monogram Consumer Service Department, 725 Landwehr Road, Northbrook, Illinois 60062

Be sure to include the plan number (85282800200), part number, description, your return address and phone number.

Visit our website: www.revellmonogram.com

1

SUSPENSION ASSEMBLY

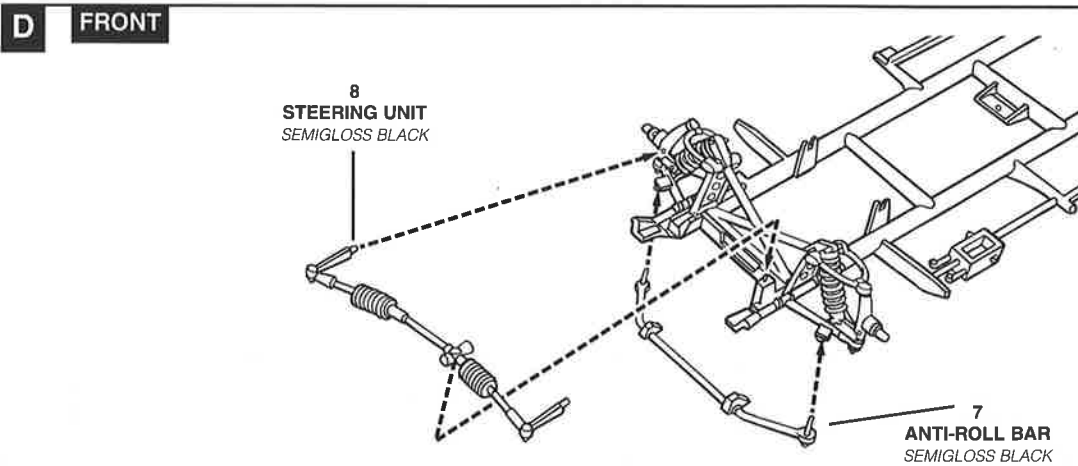
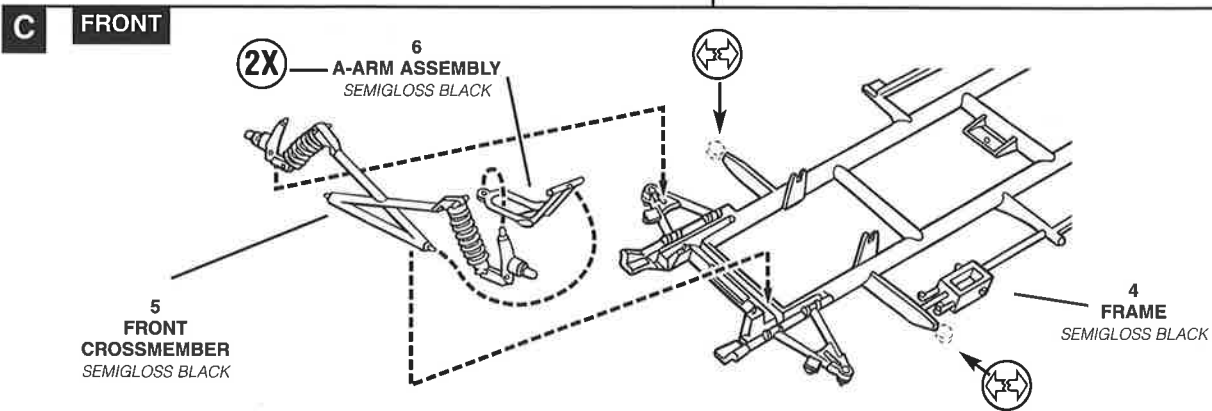
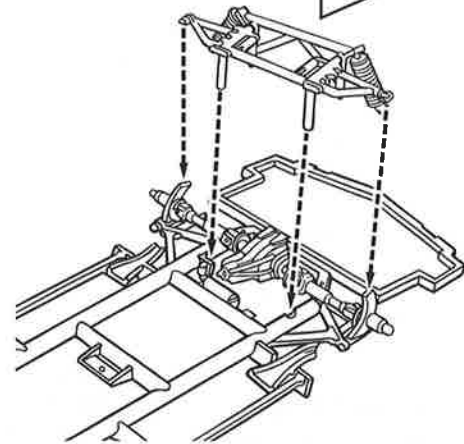
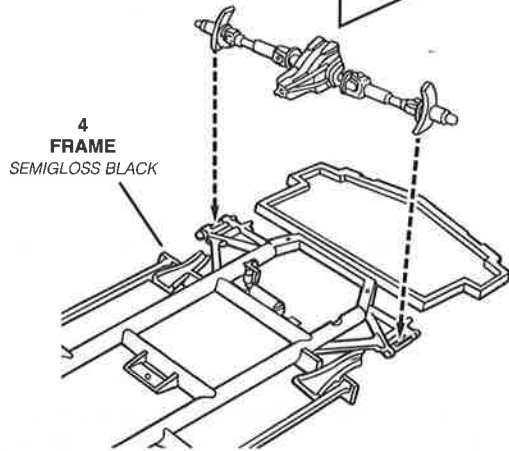
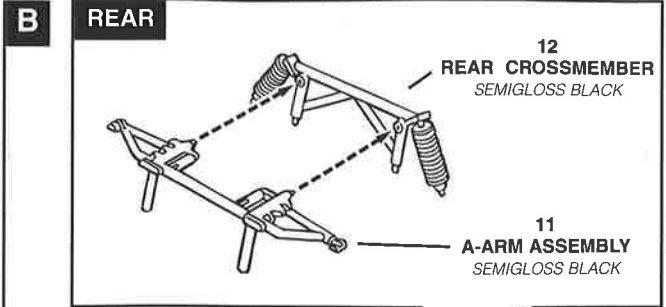
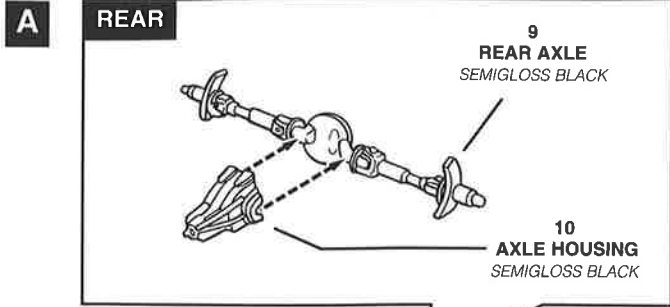

2

ENGINE ASSEMBLY

A

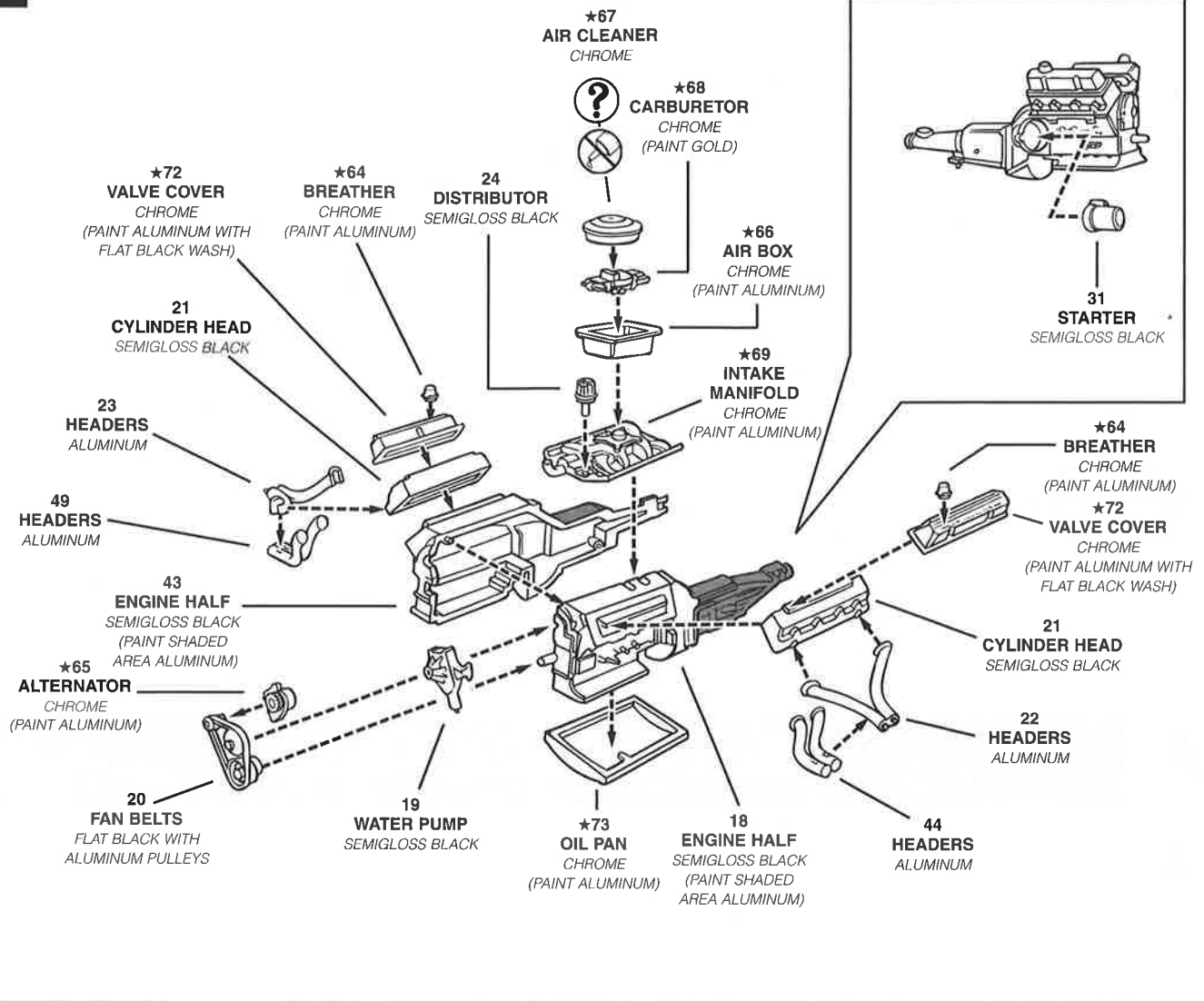

B

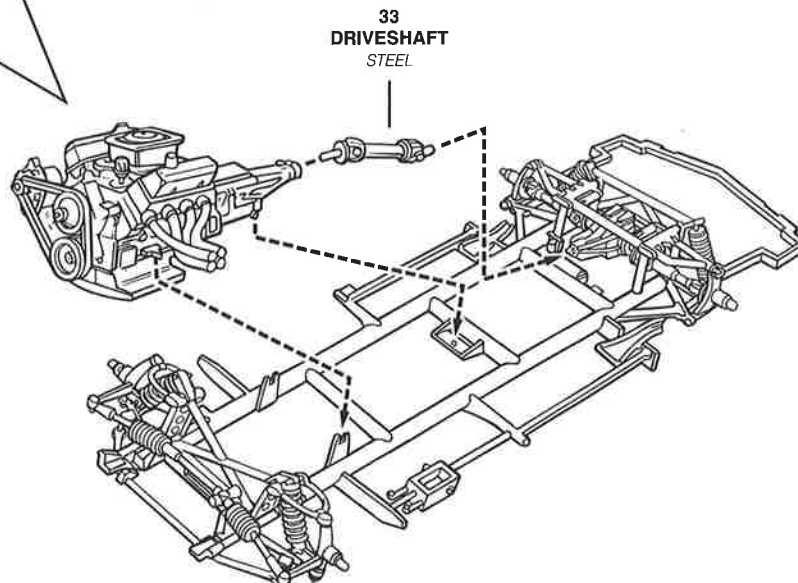

3

INTERIOR ASSEMBLY

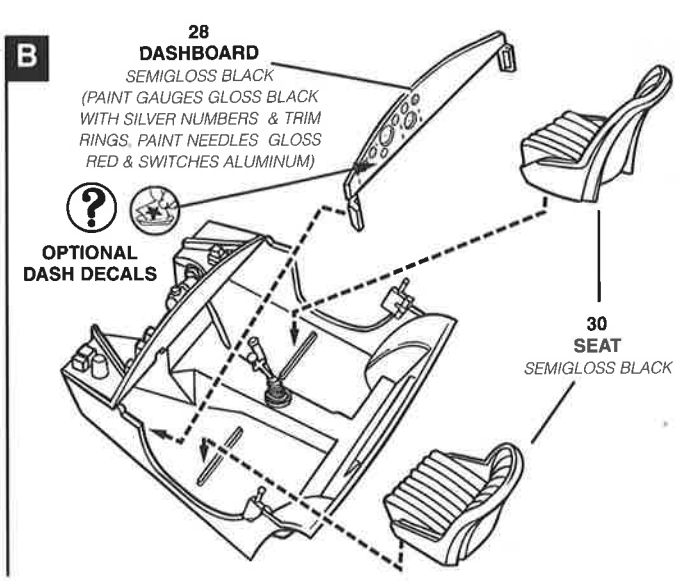
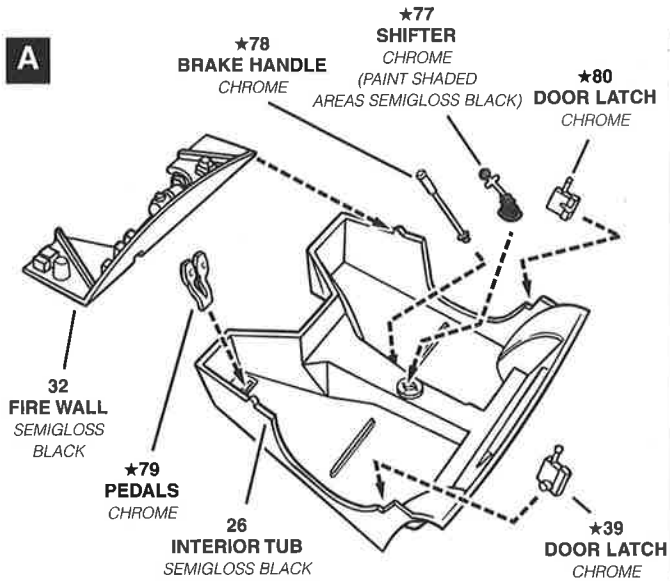

OPTIONAL
DASH DECALS

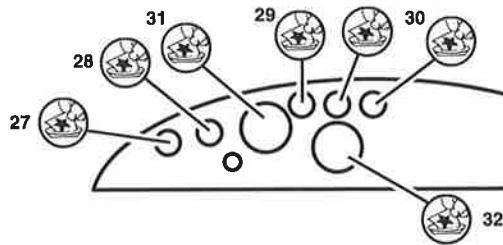

28 DASHBOARD
SEMIGLOSS BLACK
(PAINT GAUGES GLOSS BLACK
WITH SILVER NUMBERS & TRIM
RINGS, PAINT NEEDLES GLOSS
RED & SWITCHES ALUMINUM)

4

BODY ASSEMBLY

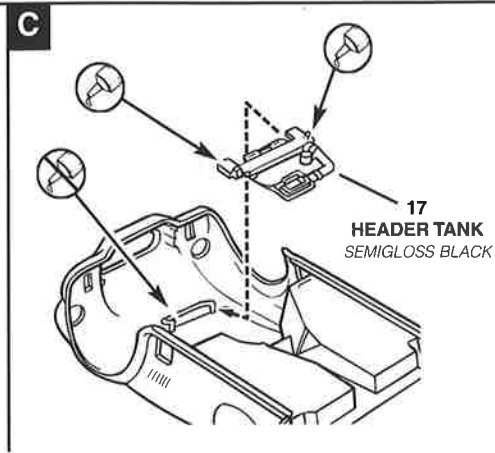
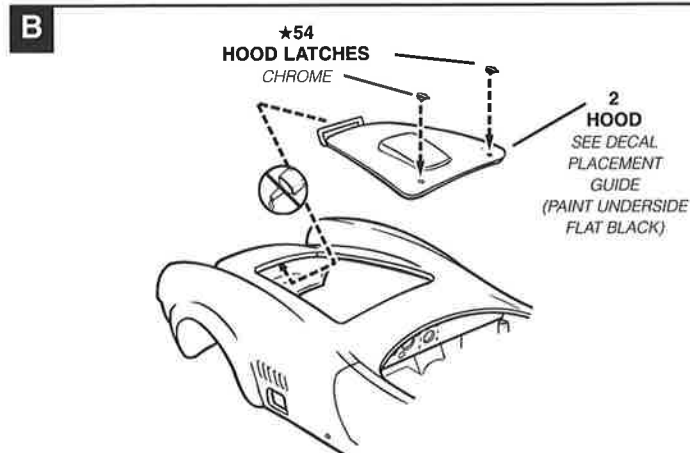
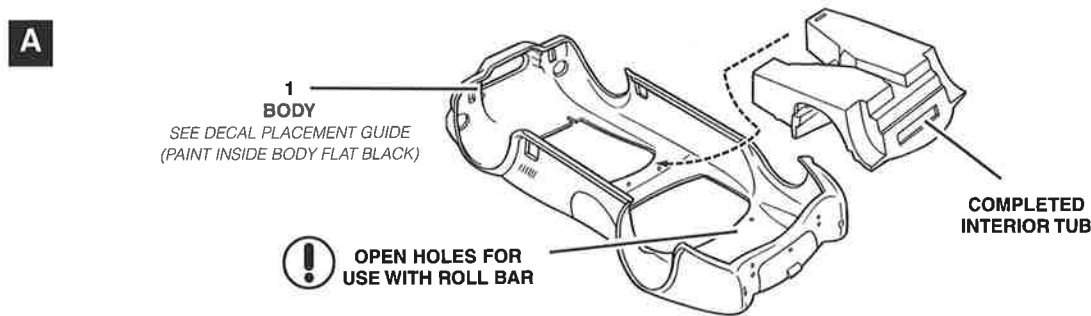

5

COOLING SYSTEM ASSEMBLY

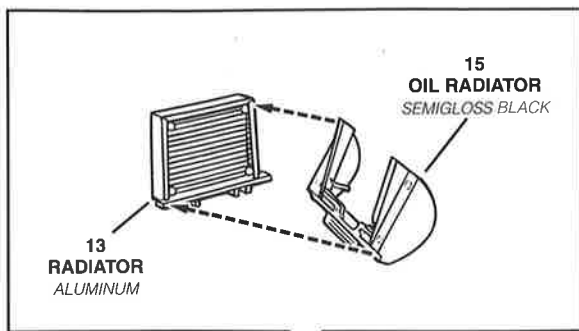

16 RADIATOR HOSE FLAT BLACK

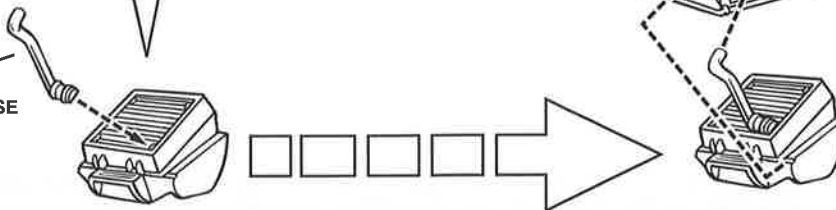

6

TIRE AND WHEEL ASSEMBLY

FRONT WHEEL & TIRE ASSEMBLY

2X

200 FRONT TIRE

34 INNER WHEEL ALUMINUM



★82 HALIBRAND WHEEL CHROME
(PAINT - SEE DECAL PLACEMENT GUIDE)

★84 KNOCK-OFF HUB CHROME
(PAINT ALUMINUM)

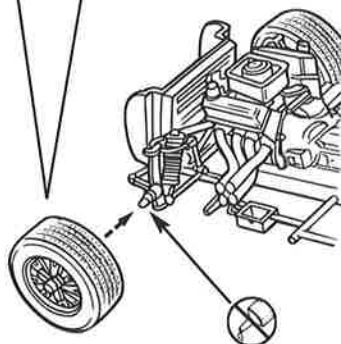

REAR WHEEL & TIRE ASSEMBLY

2X

300 REAR TIRE

35 INNER WHEEL ALUMINUM

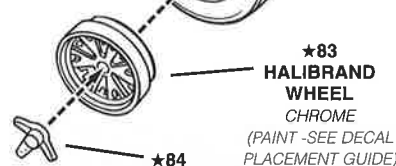

★83 HALIBRAND WHEEL CHROME
(PAINT - SEE DECAL PLACEMENT GUIDE)

★84 KNOCK-OFF HUB CHROME
(PAINT ALUMINUM)

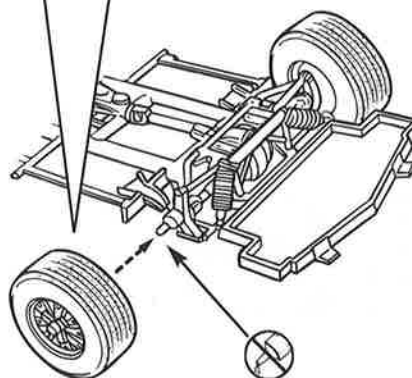

7

FRONT END ASSEMBLY

A

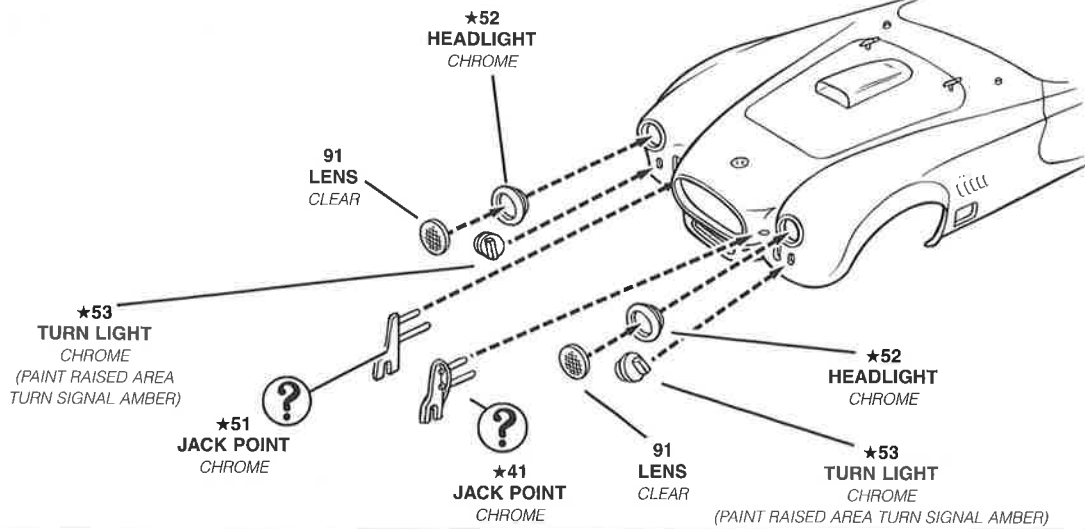

*** NOTE: APPLY STRIPE DECALS BEFORE ATTACHING THESE PARTS. SEE DECAL PLACEMENT GUIDE.**

B

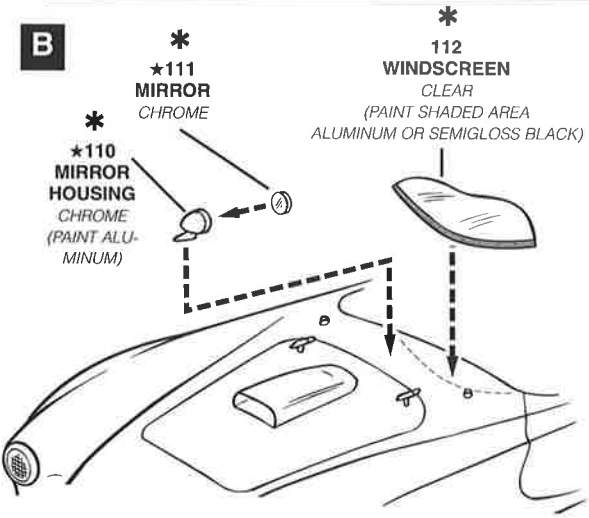

C

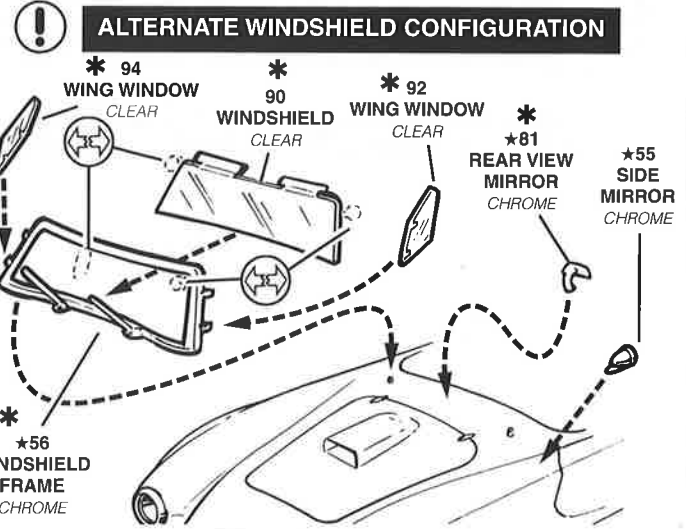

8

FINAL ASSEMBLY

A

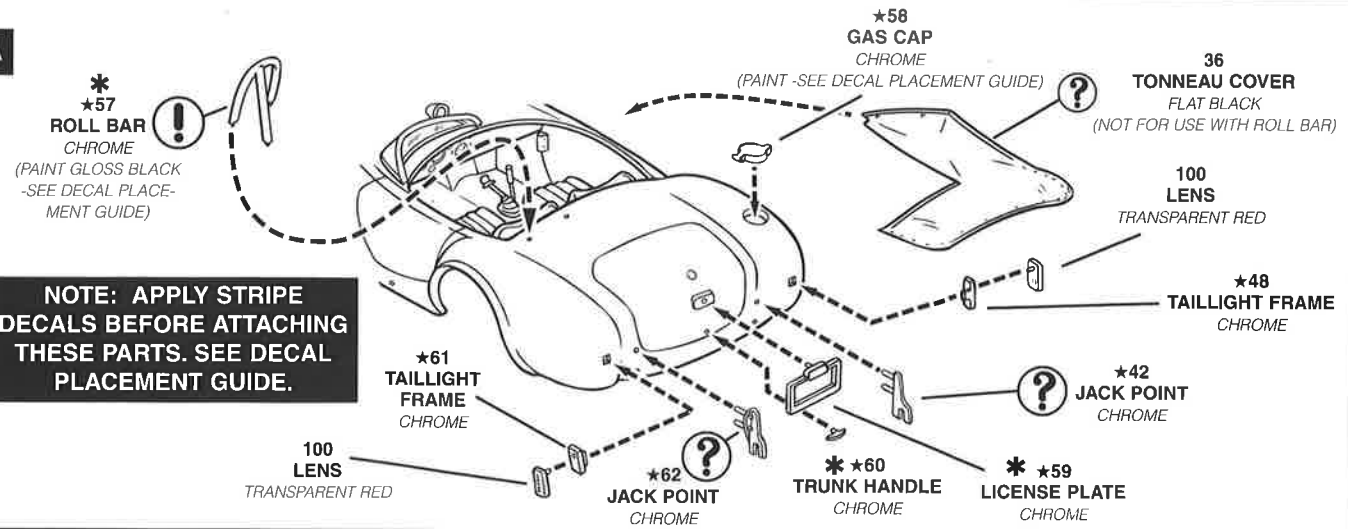

*** NOTE: APPLY STRIPE DECALS BEFORE ATTACHING THESE PARTS. SEE DECAL PLACEMENT GUIDE.**

8

FINAL ASSEMBLY CONTINUED

B

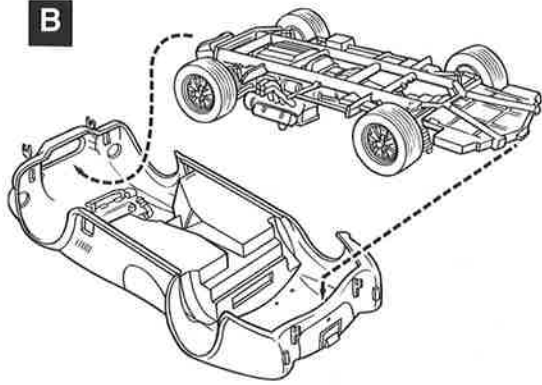

★75
SIDE PIPE
CHROME
(SEE DECAL PLACE-
MENT FOR COLORS)
(REPEAT FOR OTHER
SIDE USING PART # 74)

★46
SIDE PIPE
CHROME
(SEE DECAL PLACE-
MENT FOR COLORS)
(REPEAT FOR OTHER
SIDE USING PART #47)

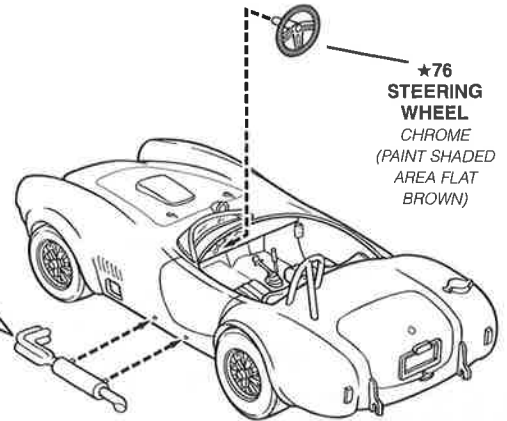

★76
STEERING
WHEEL
CHROME
(PAINT SHADED
AREA FLAT
BROWN)

9

DECAL PLACEMENT



427 COBRA A PRODUCTION NATIONAL CHAMPIONSHIP 1965
PAINT GUARDSMAN BLUE

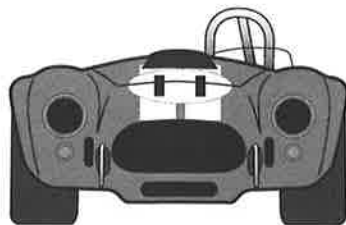
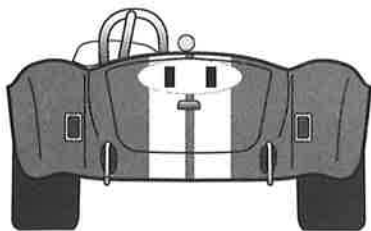
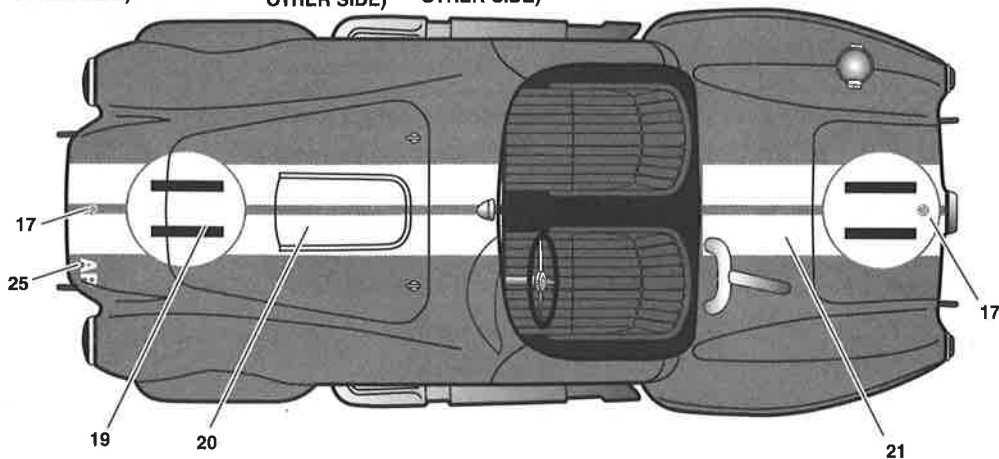
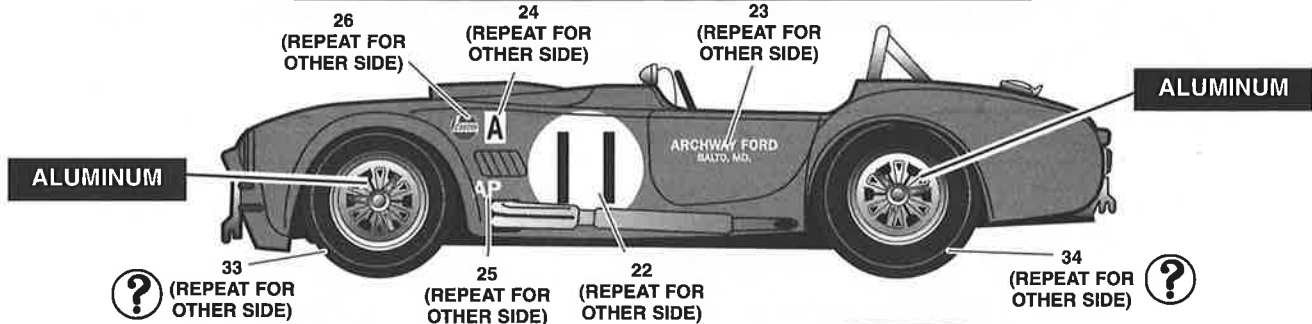

PAINT SIDE PIPES OVERALL BURNT IRON
FADED TO GUNMETAL NEAR THE EXHAUST TIP

9

DECAL PLACEMENT CONTINUED



427 COBRA A PRODUCTION NATIONAL CHAMPIONSHIP 1973
PAINT DARK GREEN METALLIC

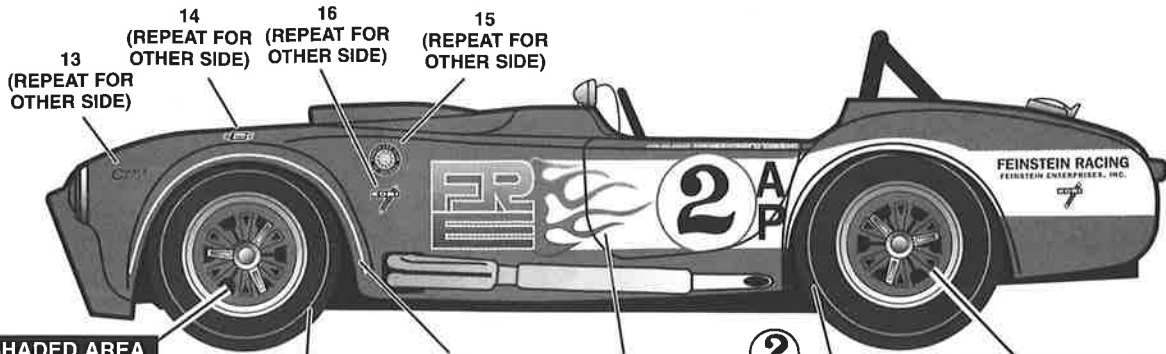

PAINT SHADED AREA
DARK GREEN METAL-
LIC WITH ALUMINUM
SPINNER AND RIMS



(REPEAT FOR
OTHER SIDE)

3
(4 FOR
OTHER SIDE)

1
(2 FOR
OTHER SIDE)



34
(REPEAT FOR
OTHER SIDE)

PAINT SHADED AREA DARK
GREEN METALLIC WITH ALU-
MINUM SPINNER AND RIMS

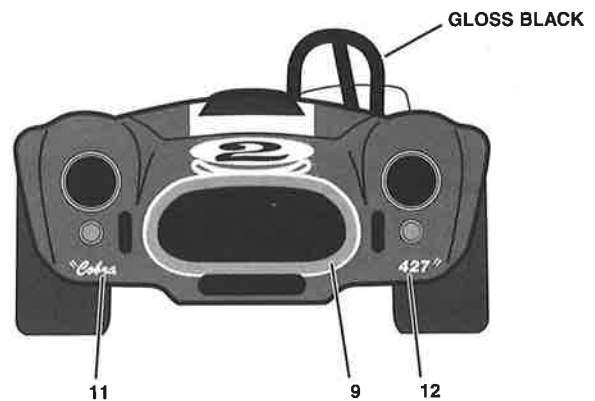
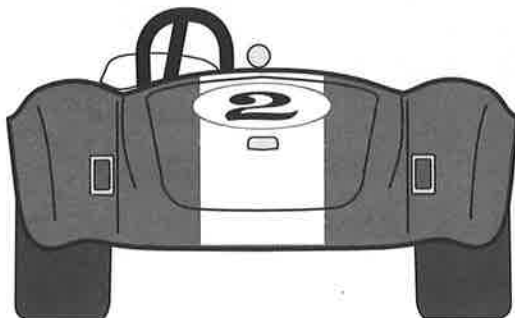
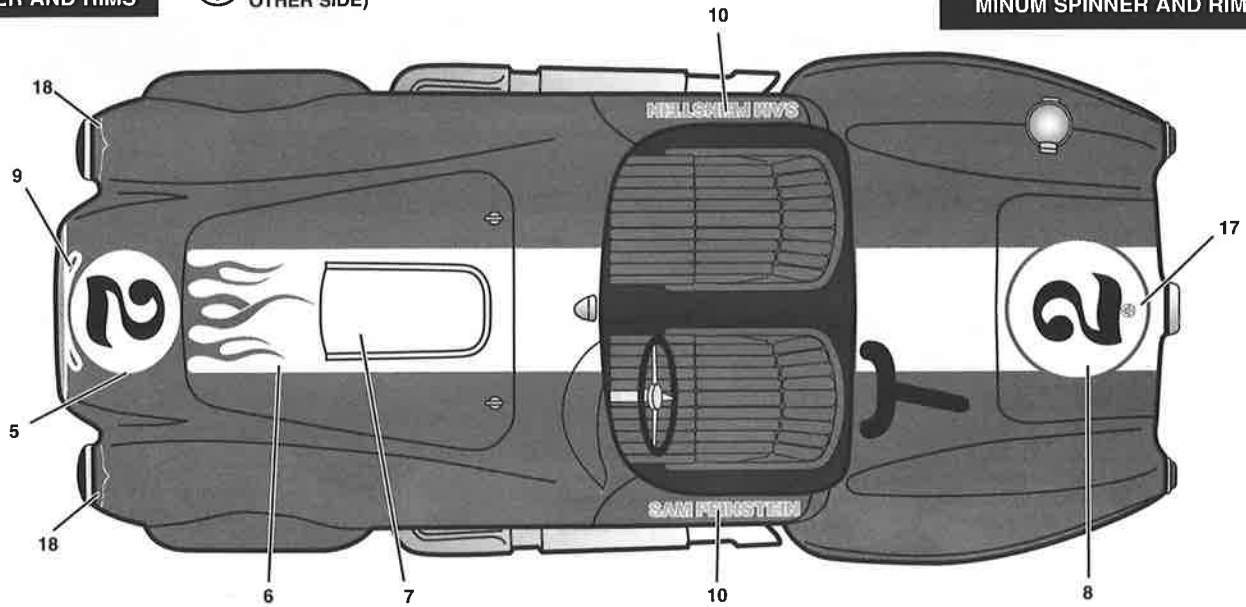

PAINT SIDE PIPES OVERALL ALUMINIUM FADED
TO BURNT IRON TOWARDS HEADERS

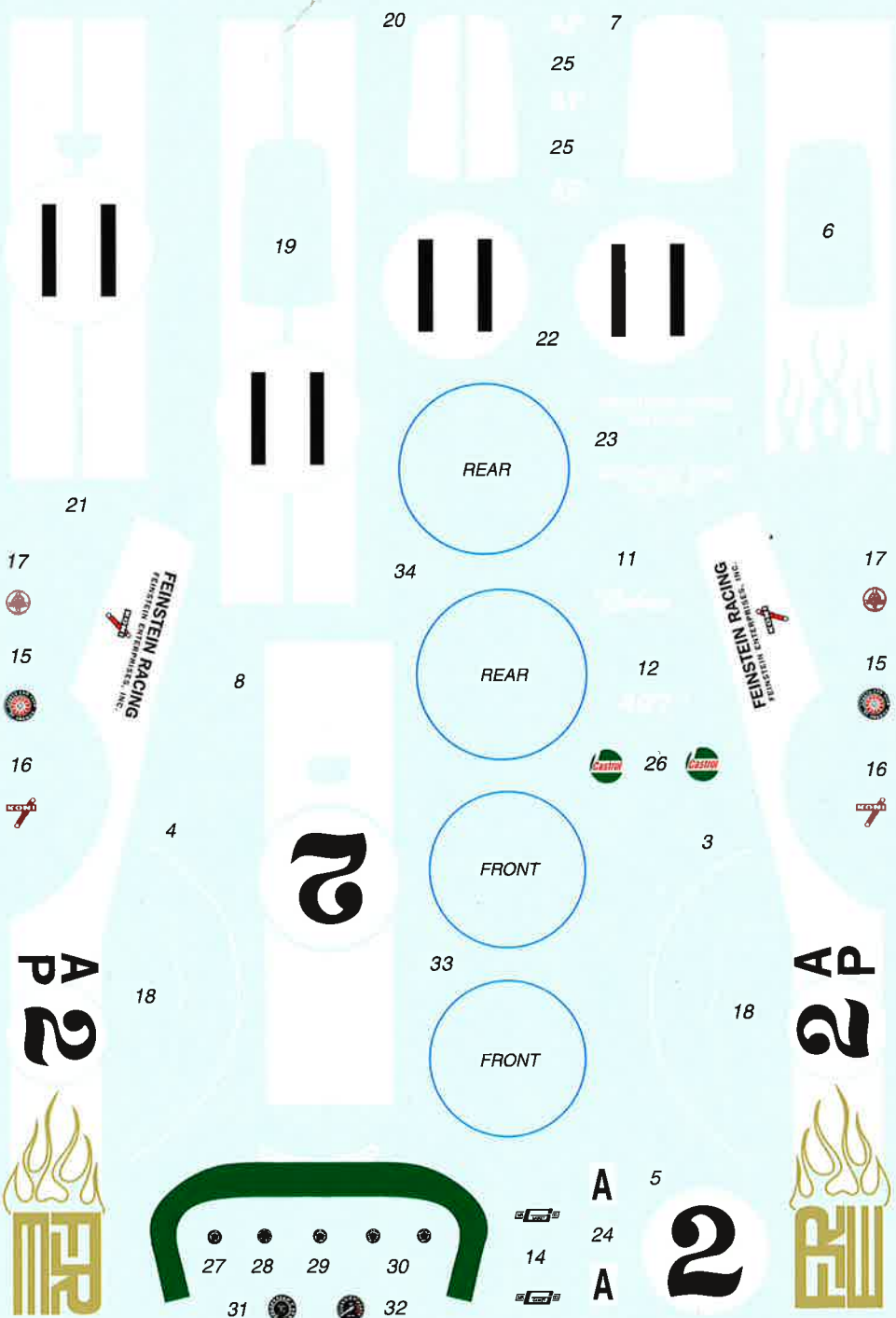

17
15
16

17
15
16

A
2
P

FR

A
2
P

FR