

# Thunder

MODEL

迅雷模型

www.migjimenez.com



# German Flat Wagon Ssy1

Ref: TM-35904

## Painting and Marking Guide

A.MIG-0250 Night Blue Grey

A.MIG-0036 Old wood

A.MIG-0037 New wood

A.MIG-0038 Light wood

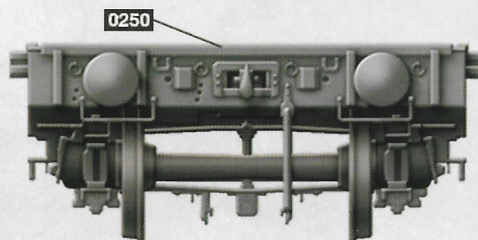
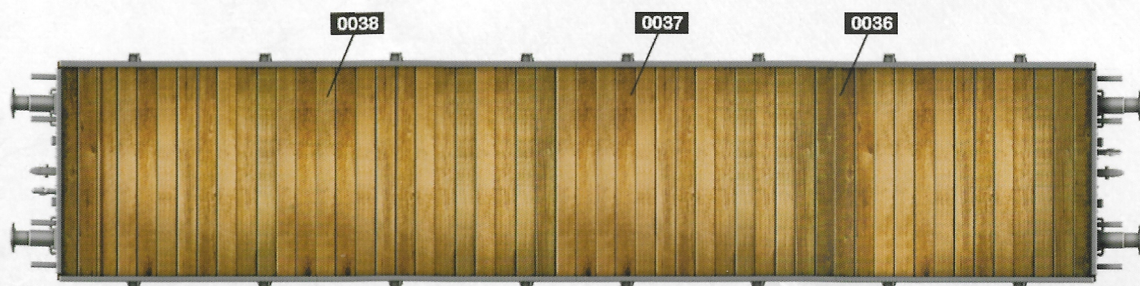
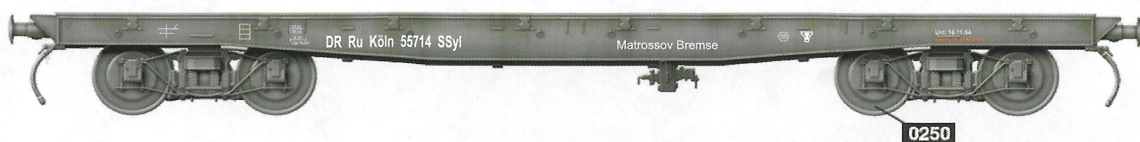

### WEATHERING STEPS WITH AMMO PRODUCTS

#### 1 GENERAL WASH

A.MIG-1006 Blue Wash for Panzer Grey

#### 2 WOOD WASH

A.MIG-1003 Interiors Wash

#### 3 WOOD FILTER

A.MIG-1500 Brown for White

#### 4 STREAKING

A.MIG-1202 Streaking Grime for Panzer Grey

#### 5 RUST

A.MIG-3510 Rust

#### 6 DUST

A.MIG-3013 Rubble

#### 7 POLISHED METAL

A.MIG-3021 Polished Metal

#### 8 GREASE & OIL

A.MIG-1408 Fresh Engine Oil



A.MIG-0250 Night Blue Grey

A.MIG-0036 Old wood

A.MIG-0037 New wood

A.MIG-0038 Light wood

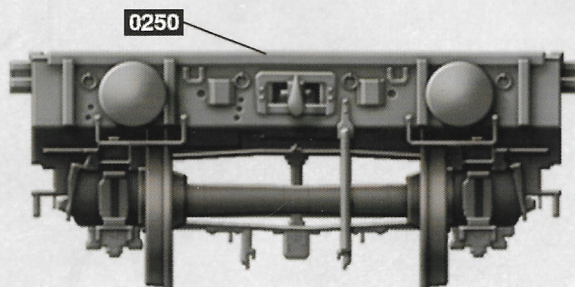
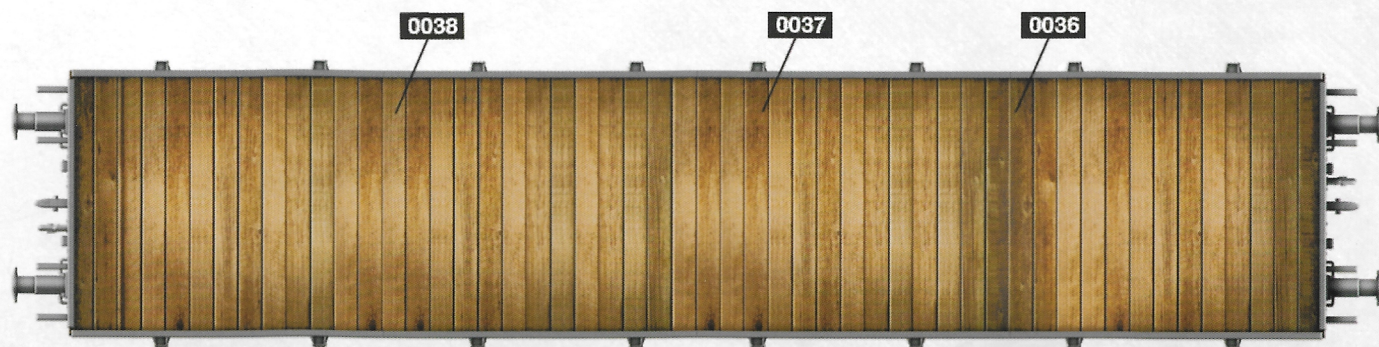

#### WEATHERING STEPS WITH AMMO PRODUCTS

**1 GENERAL WASH**

A.MIG-1006 Blue Wash for Panzer Grey

**3 WOOD FILTER**

A.MIG-1500 Brown for White

**5 RUST**

A.MIG-3510 Rust

**7 POLISHED METAL**

A.MIG-3021 Polished Metal

**2 WOOD WASH**

A.MIG-1003 Interiors Wash

**4 STREAKING**

A.MIG-1202 Streaking Grime for Panzer Grey

**6 DUST**

A.MIG-3013 Rubble

**8 GREASE & OIL**

A.MIG-1408 Fresh Engine Oil



# 35904

# scale 1/35

## 產品編號: 35904

## 1:35 比例

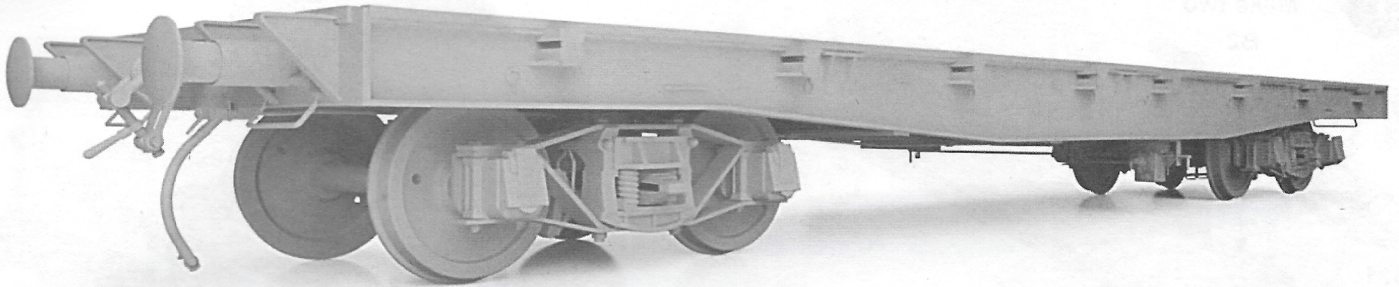

### 1/35 German Ss1 Platform Wagon

Go through this assembly guide and understand it before you start kit assembly  
 Use usual plastic kit's cements and tools (not included in the kit)  
 Follow painting guide supplied, use only hobby paints  
 Work carefully with photo etched parts if included, use C/A glues to assemble them

請您在組裝此產品前仔細閱讀組裝指南;  
 請使用通用塑膠模型黏合劑和工具(本產品不附帶);  
 本產品所以提供的噴塗指南只適用本於模型;  
 如果本產品含有蝕刻套件,請小心仔細處理, 請使用C/A膠水組裝;

組み立て前にこの組み立てガイドをご覧ください。  
 プラスチックキット専用接着剤と専用工具をご使用ください。(ともにキットには含まれていません)  
 塗装ガイドに従ってください。専用塗料をご使用ください。  
 エッチングパーツの組み立ては細かいパーツのため注意が必要です。また接着には瞬間接着剤を使用してください。

	cut/remove	切下 / 移除	切断/切り離し
	drill hole	鑽孔	ドリル穴
	no glue	不適用膠水	接着しない
	bend	折彎	折り曲げ
	cyanoacrylate glue	氰基丙烯酸酯膠水	瞬間接着剤
	string or wire	細繩或者金屬絲線	糸または金属線
	rope	繩	ひも
	paint area during assembly (ref. to AMMO colors)	裝配過程中的噴漆區域推薦 (請參考AMMO顏色)	組み立て時の塗装部分 (コード例: AMMOカラー)
	PE - press rivets (lines) from the etched off side	蝕刻片 - 請从蝕刻掉的一側压铆釘 (线)	ラインやリベット部分を未エッチング面から圧を与える



During WWII many Russian wagons of different types and age were captured and then used in German service. Among them there were hundreds of 50t four-axle almost new flatbeds and low sided wagons. Some minor changes were made by wagon factory in Koln, German bogies - usually just axles with wheels - replaced, if not changed already earlier right after the capture, couplings, sometimes buffers and brake system, and then wagons suitable most for transport of military vehicles left immediately the factory to headed back to service. Besides of them also production of similar original German SSy wagon series were running in Koln factory.

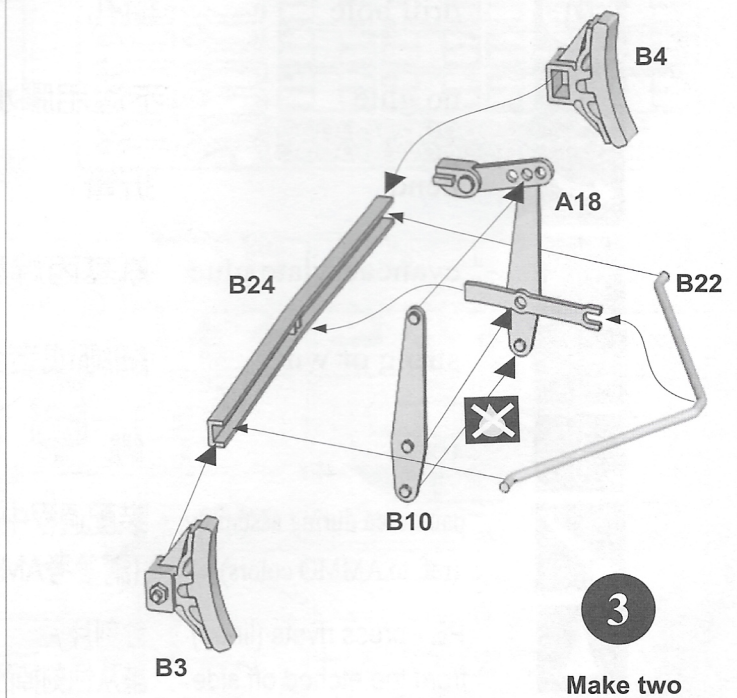
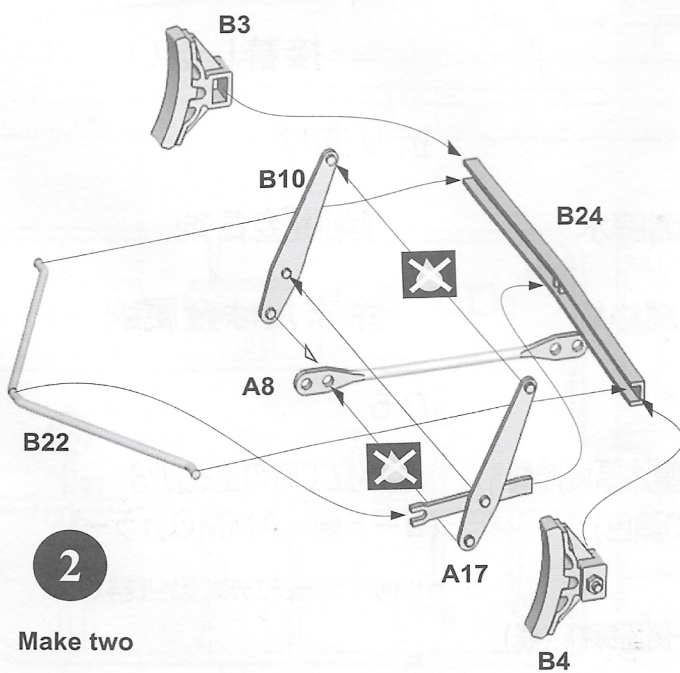
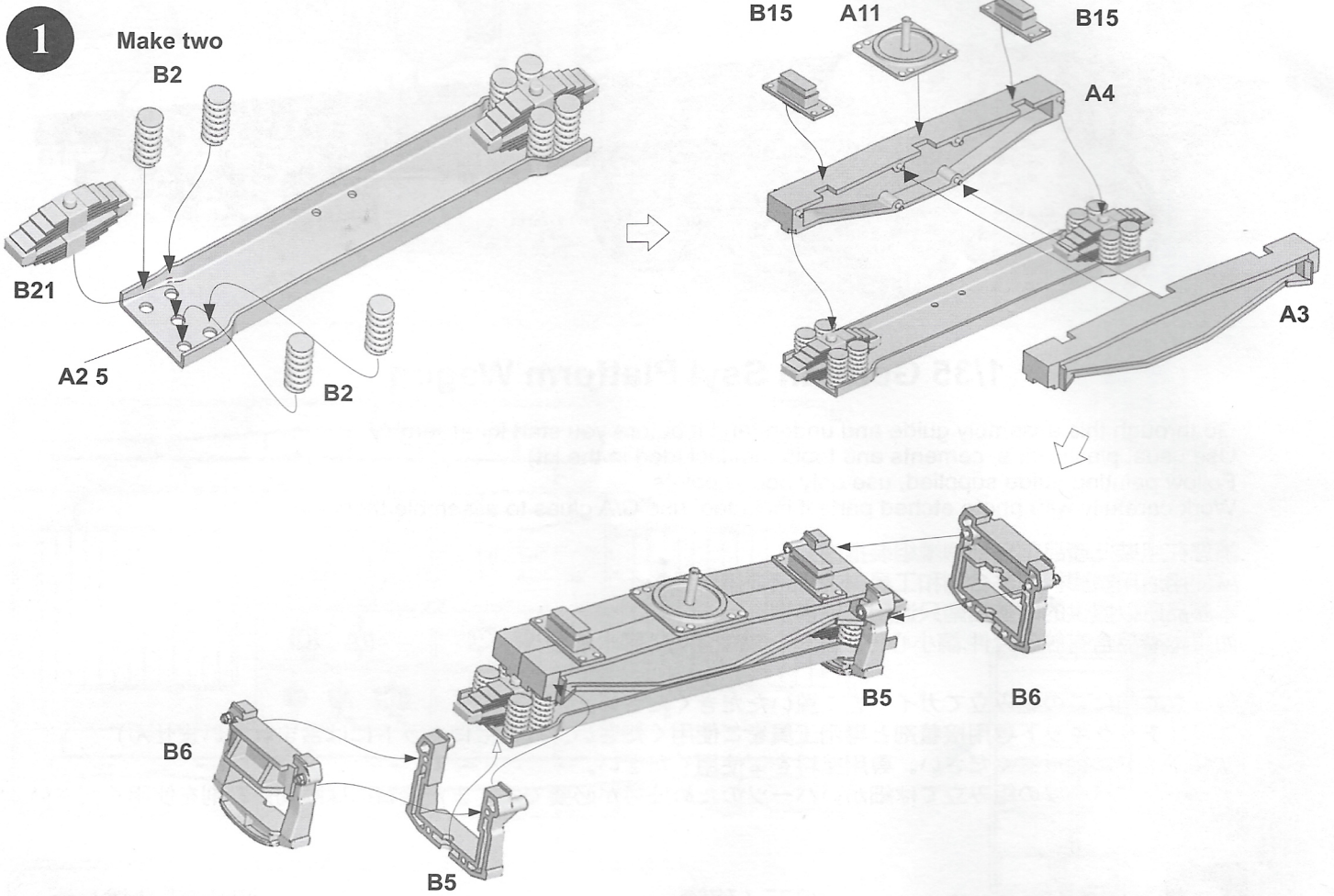



PE1  
outer

PE2  
inner

4

Make two

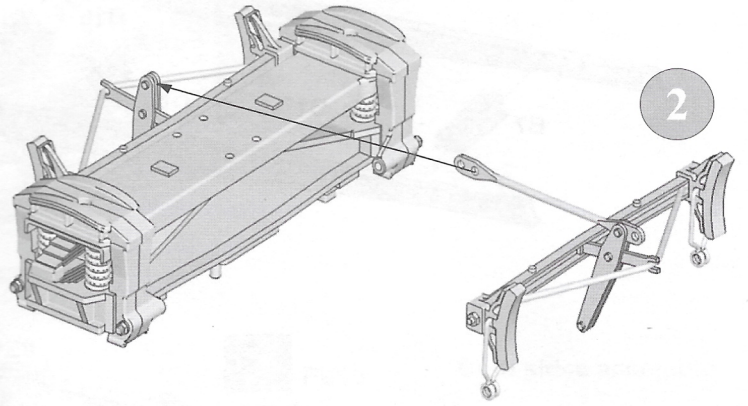
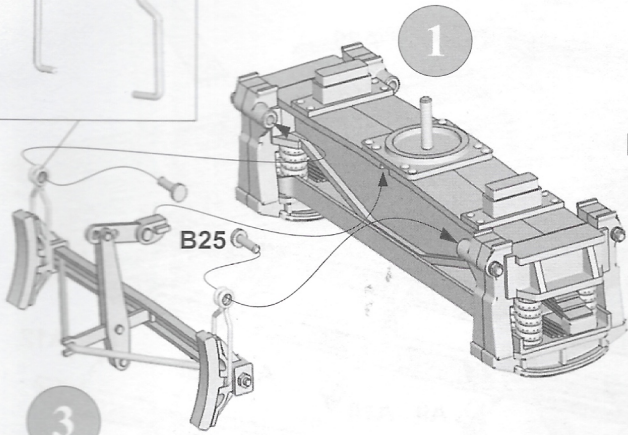

3

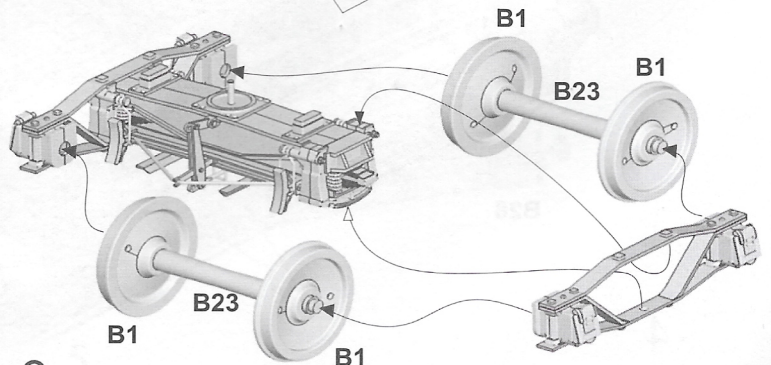
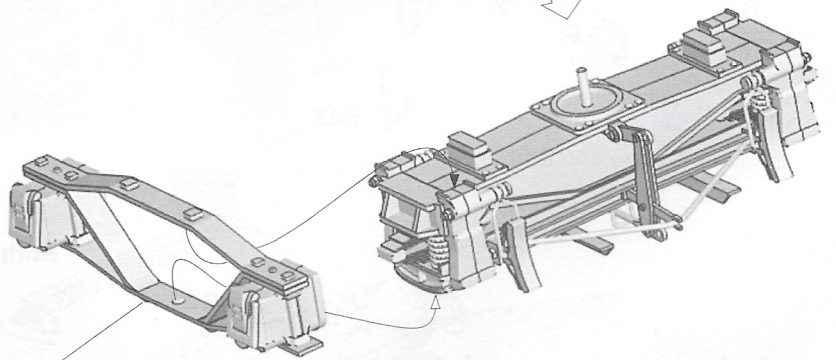
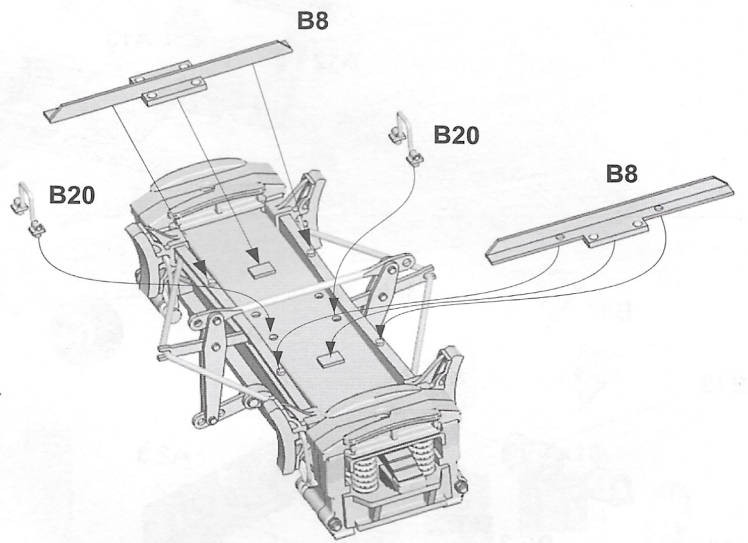
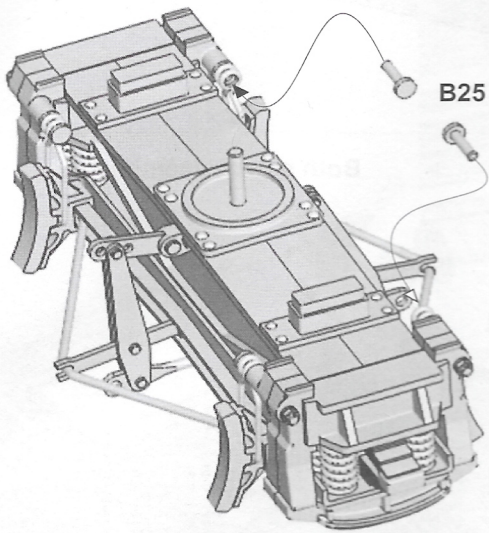

3

Make eight

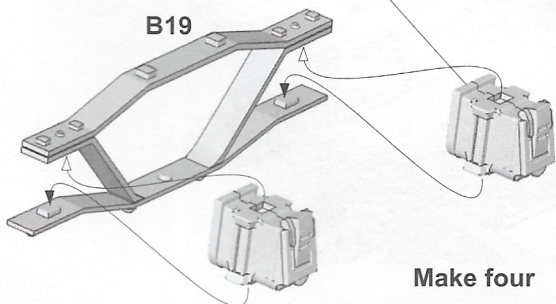
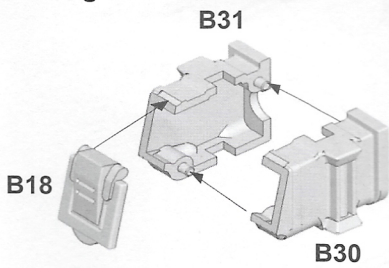



5

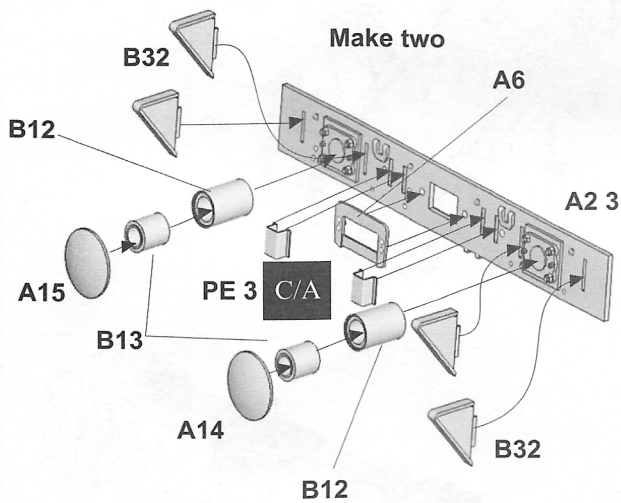
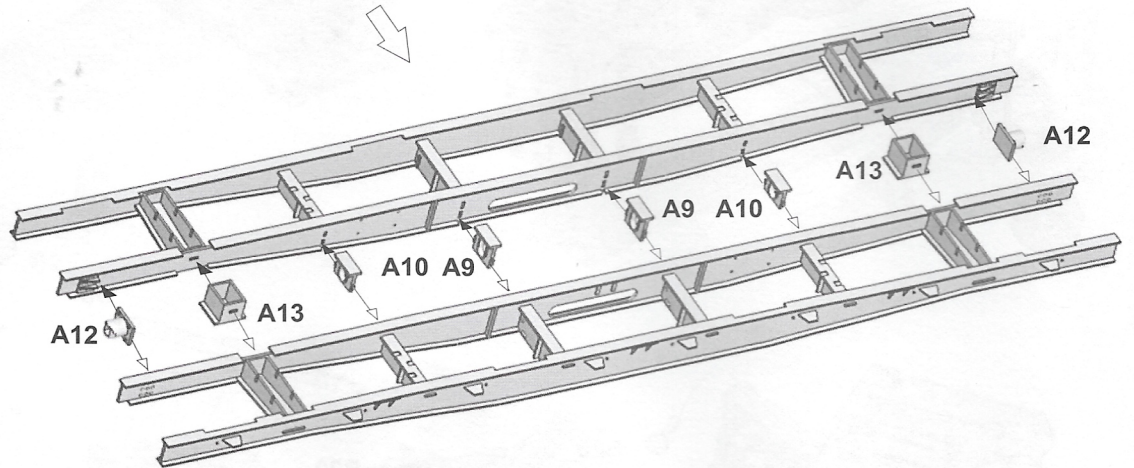
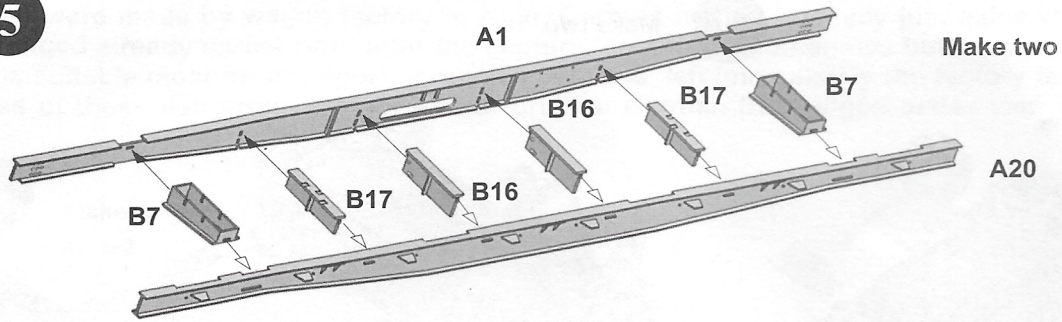

6

Both sides assembly

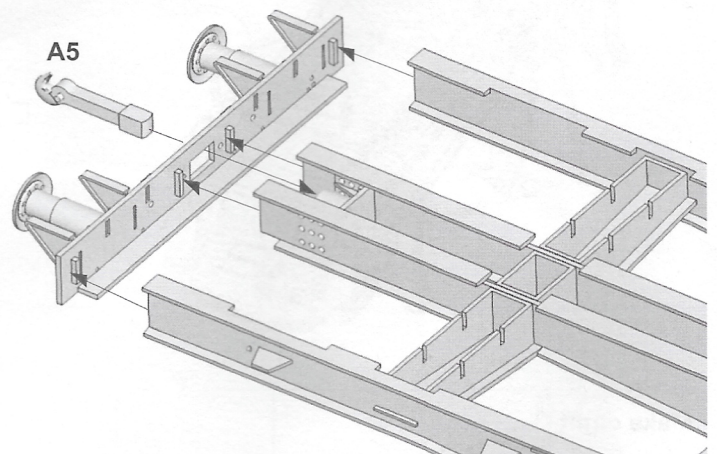

Both sides assembly

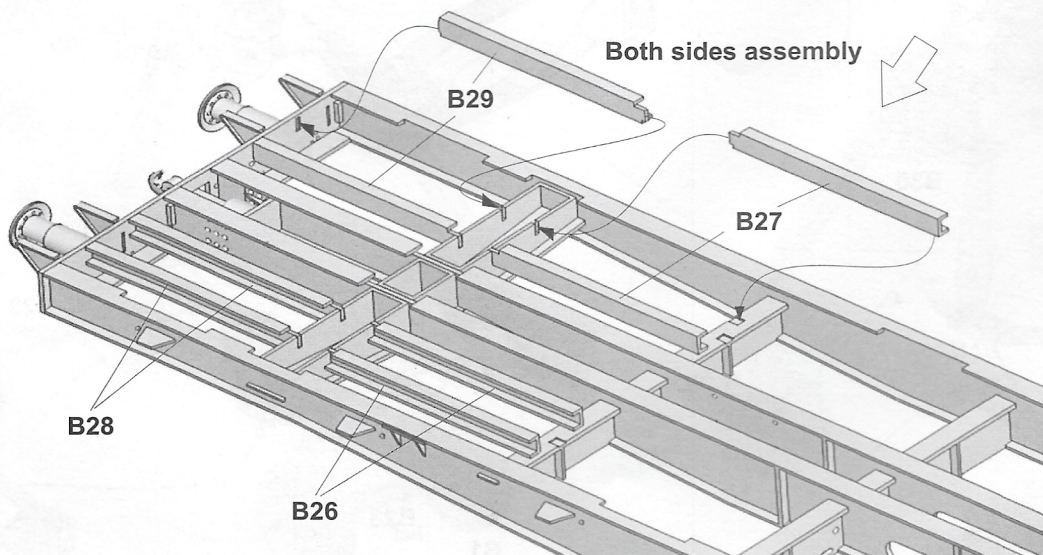

4



7

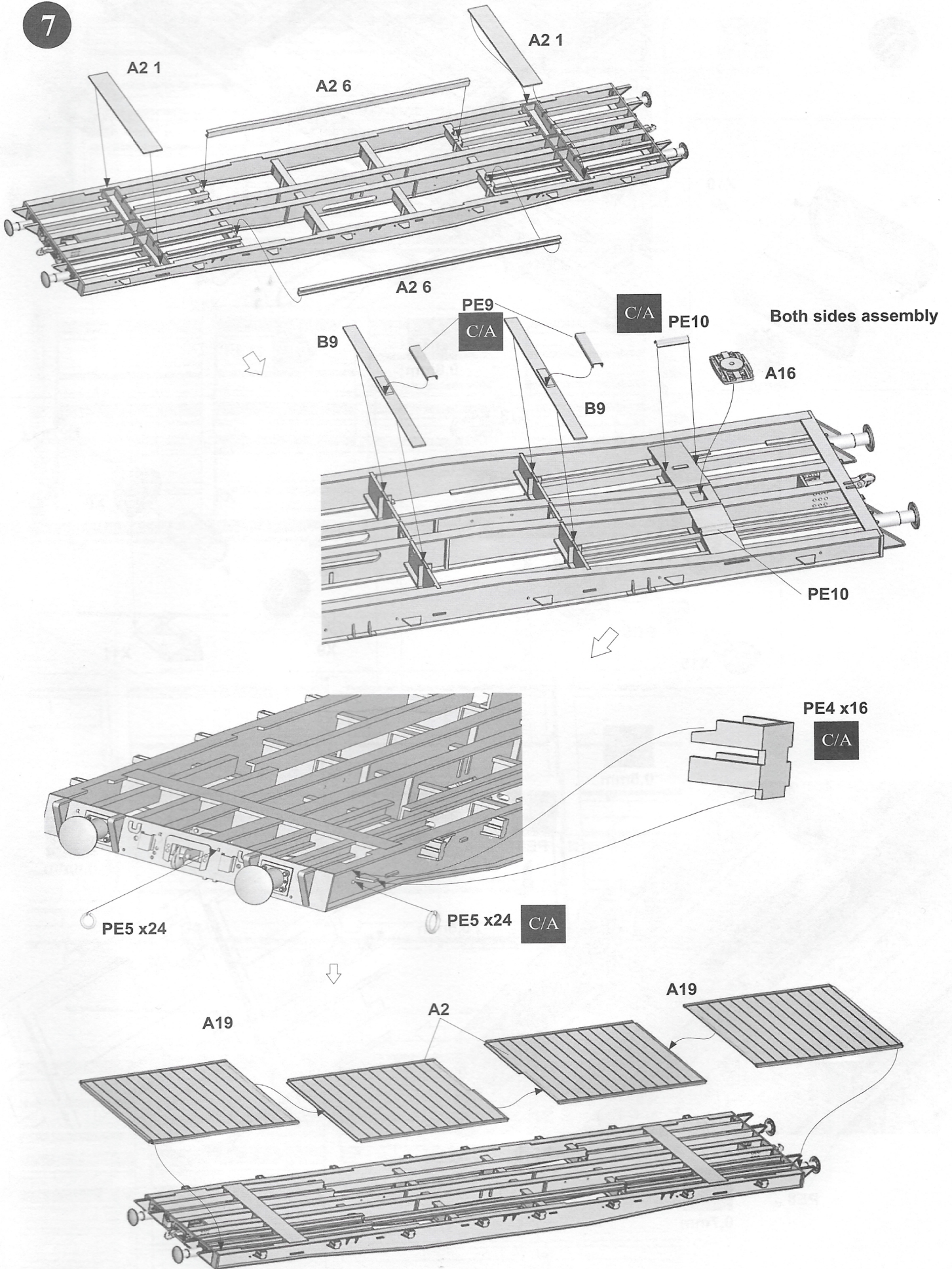



8

