

THE MERKAVA II

ISRAELI MAIN BATTLE TANK



The Merkava II main battle tank is an excellent and successful example of design by committee. When the Israeli Defence Force decided it was time to develop their own heavy tank, they drew heavily on the battle-field experience of the crews who had fought the "Six Day War" in 1967 and the "Yom Kippur War" in 1973.

ACADEMY

HOBBY MODEL KITS

Whenever possible, existing foreign components were utilized in the design to reduce costs and expedite completion. For example, the turret control system was based on the M-60 system; the original 105mm gun was based on the Vickers L-7; the road wheels are from a centurion and the mud flap design was borrowed from the T-55 and T-72 Russian tanks. Of course, many components had to be designed and made in Israel for the Merkava.

The need to fire from elevated hill positions into lower valleys, dictated the sloped, front engine layout. Designed for use in a particular location, many features of the Merkava were based on the topography of Israel and Lebanon.

Powered by a Teledyne Continental air-cooled engine that produces 1200 horsepower (895 KW), the Merkava has a top speed of 55Km/h and can accelerate from 0 to 32 km in 10 seconds. With a fully loaded combat weight of 61 tons, the Merkava II mounts a 105mm smooth bore cannon with 50 rounds and three 7.62mm machine guns with 10,000 rounds.

The Merkava II is a well thought-out tank design that has been steadily improved through actual experience in the field. It is regarded with considerable respect by its enemies.

1 Upper Body Assembly



Hatch

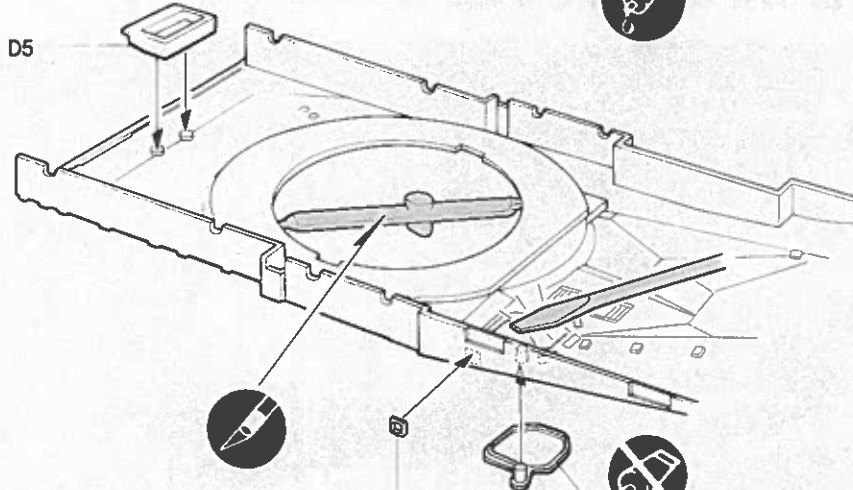

Closed

Open

FLAT RED C9

D6

Carefully melt shaft with a heated screwdriver.

Headlight



SILVER

BLACK



D20

D3

D23

C20

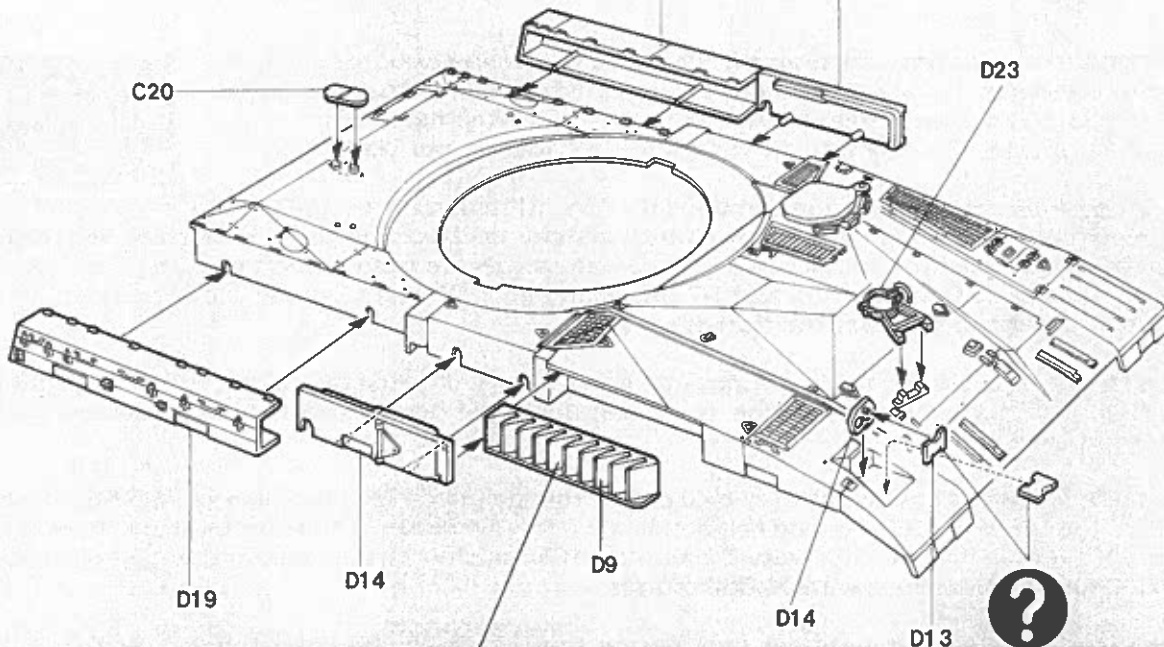

Paint FLAT BLACK inside to simulate exhaust.



Headlight: Open or closed

2 Skirt Assembly

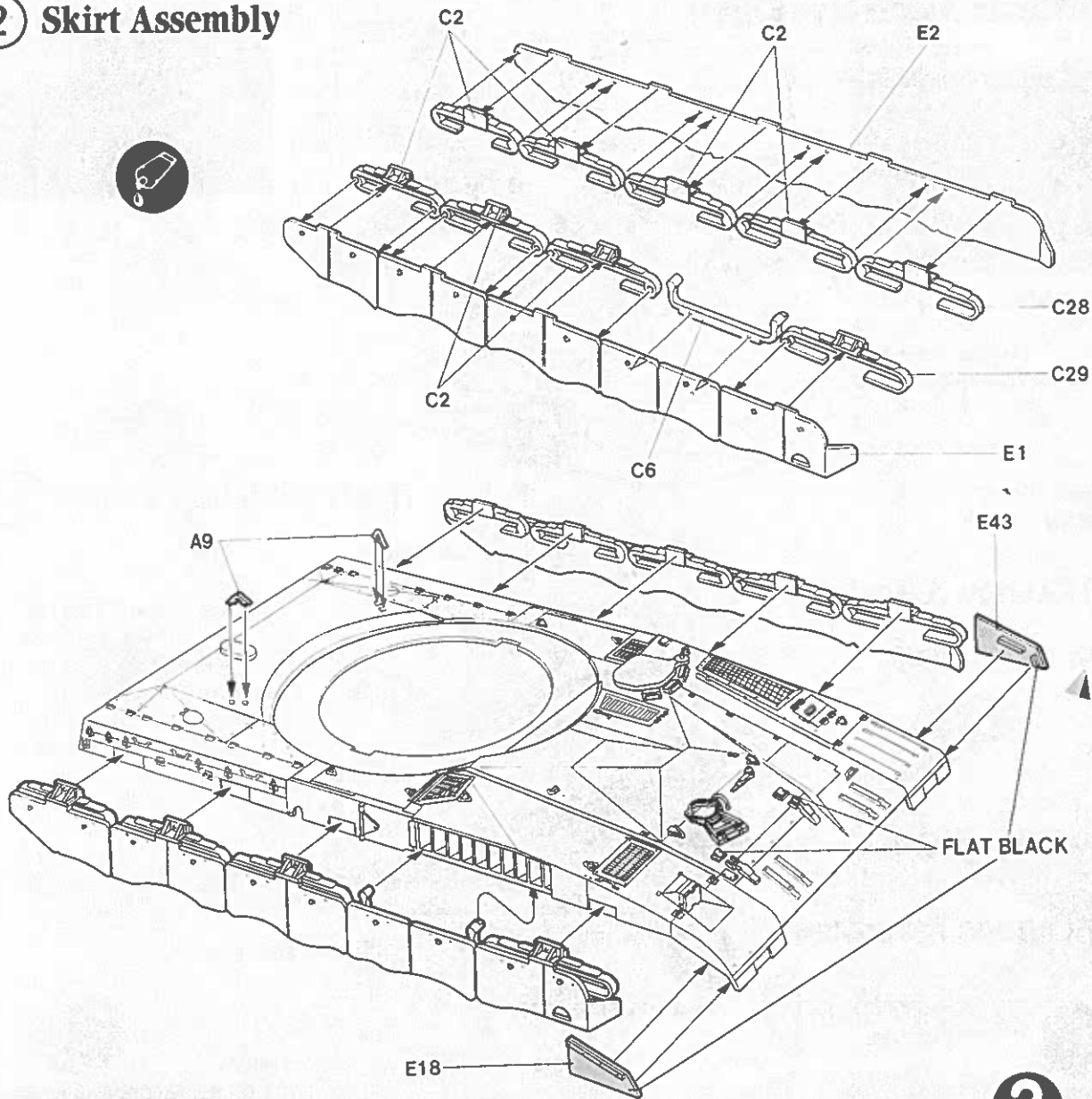

3 Commander's Hatch

Carefully melt shaft with a heated screwdriver.

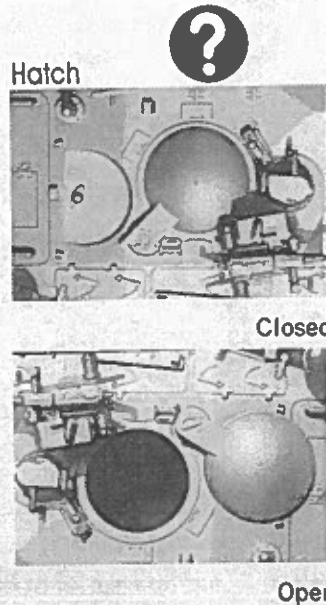
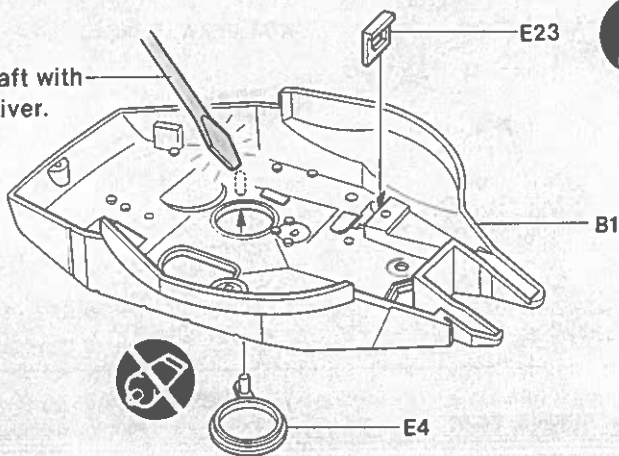

4 Turret Assembly (Right)

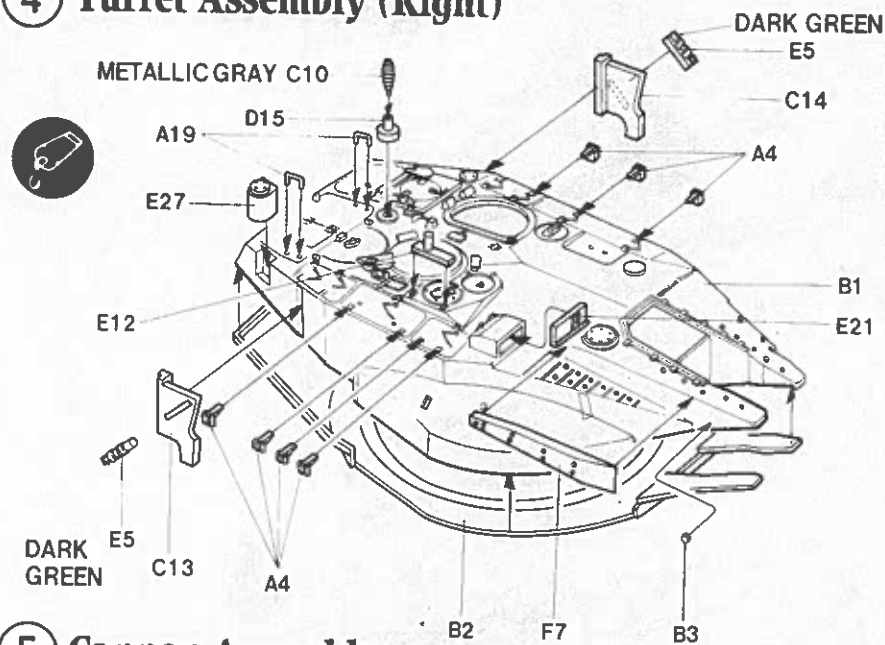

Rivet Detail on Turret

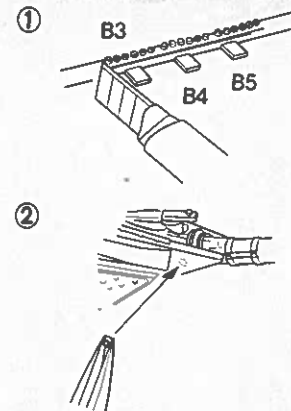

- ① Shave rivet B3 off "B" Shot. Note there are three different styles.
- ② Cement to turret as shown. Tweezers are helpful in holding B3.

5 Cannon Assembly

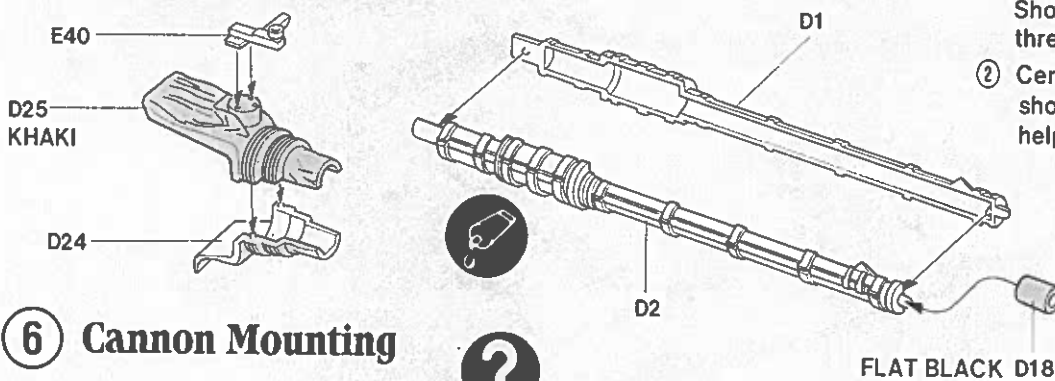

6 Cannon Mounting

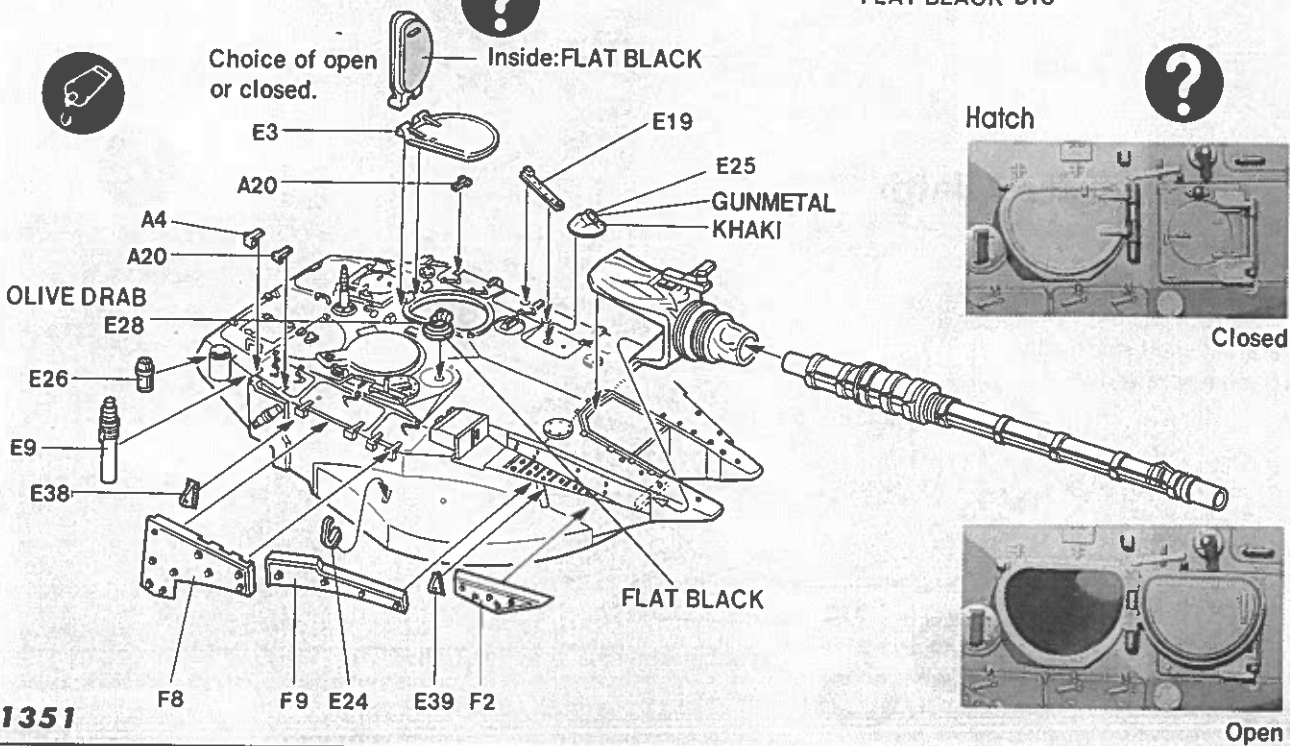

7 Stowage Basket

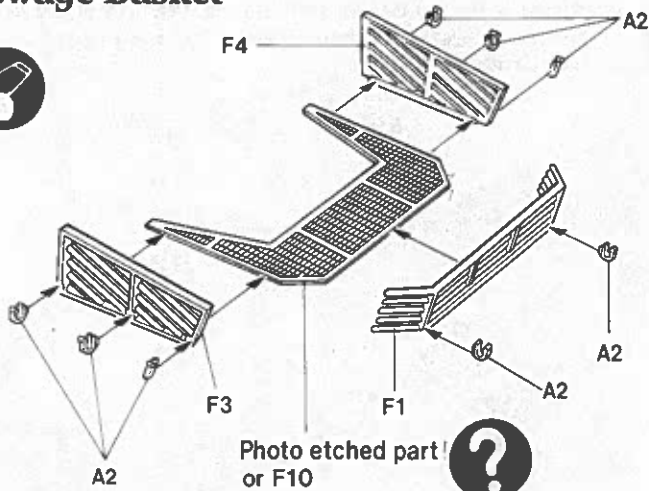

Decal Banner

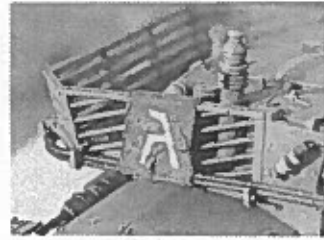

Affach decal banner as shown after turret has been completely assembled and painted.

8 Turret Assembly (Left)

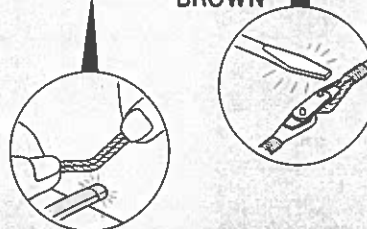
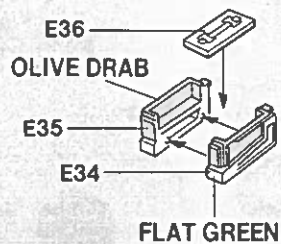
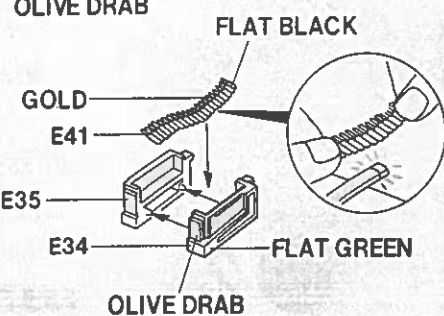
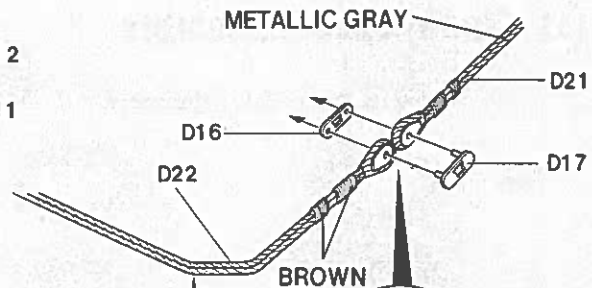
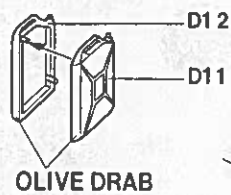
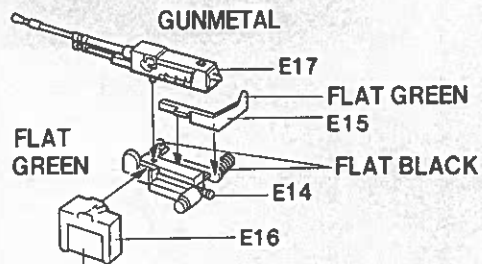
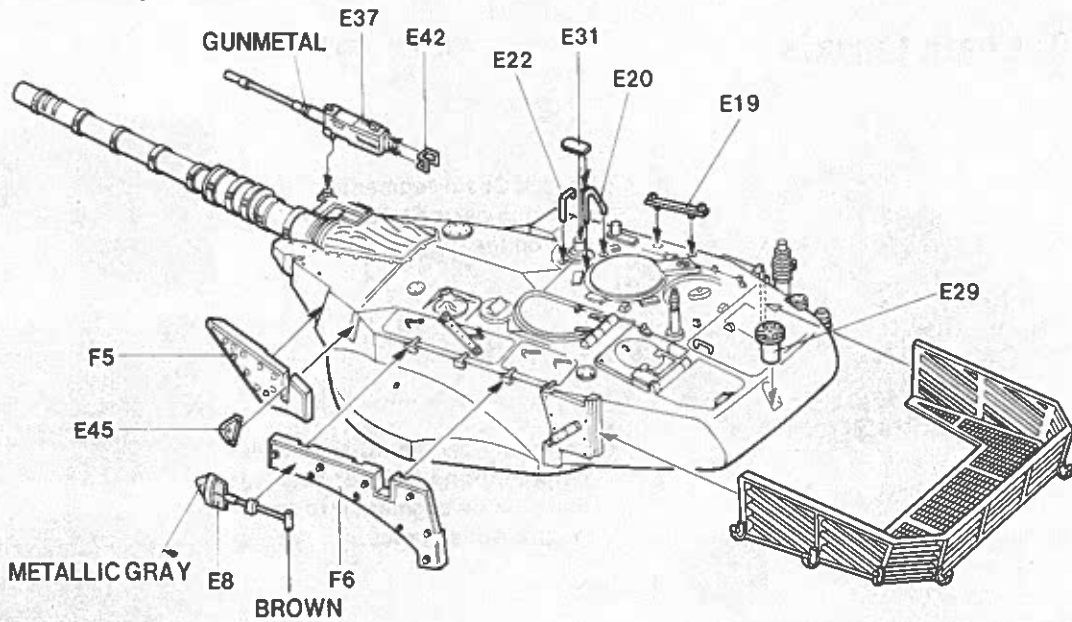

Carefully heat cables and bend them to fit the contour.

1351

9 Final Turret Assembly

Make antenna from stretched sprue. Carefully heat a piece of sprue over a candle, rolling it to heat it evenly. When soft, remove from flame and stretch. Hold until cool. Cut to desired length.



Cable Detail

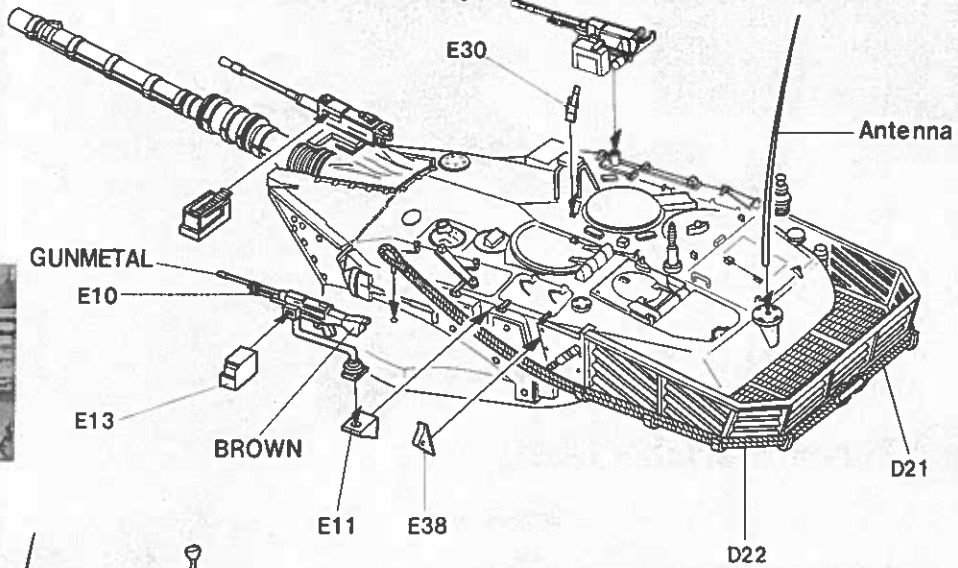
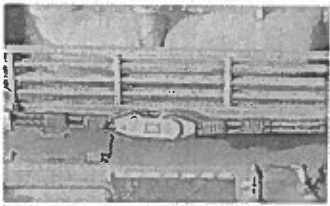

10 Chain Curtain

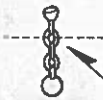
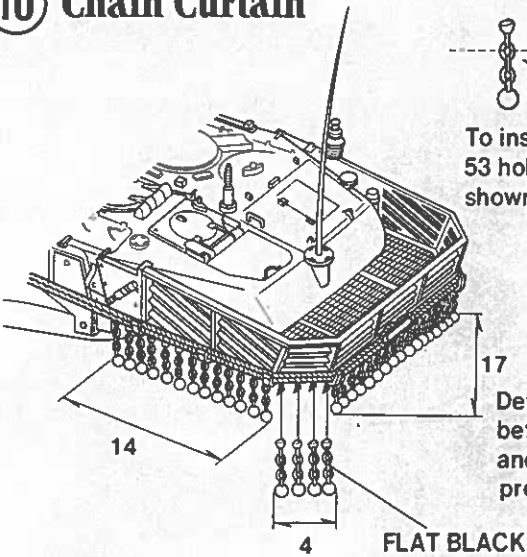

To install Chain segments, drill 53 holes in parts F1, F3 and F4 as shown on the diagram.

Determine length for each chain before cutting. Cement each cut and painted segment into the proper drilled holes.

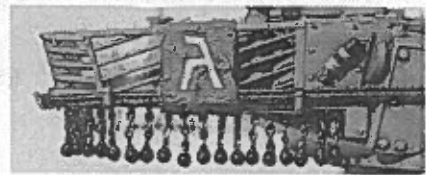
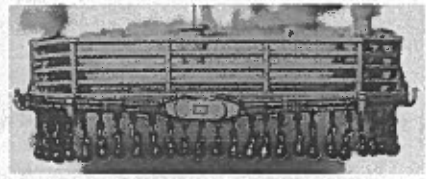
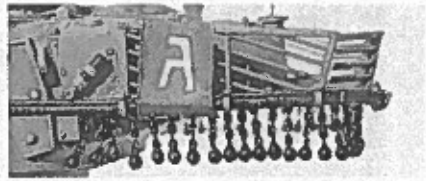

11 Road Wheel Assembly

Notice rivets on outer tires only.

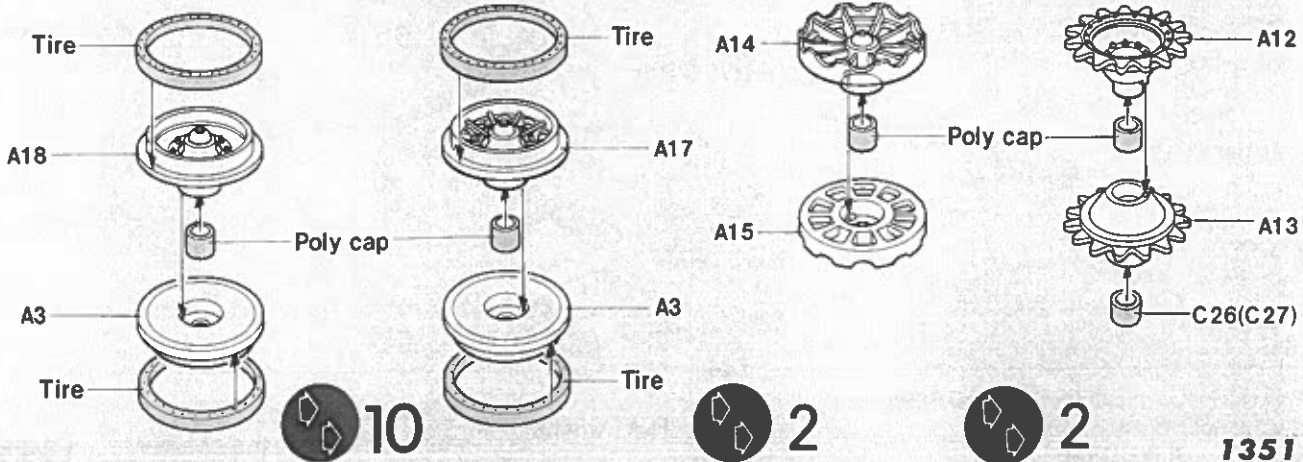

1351

12 Personnel

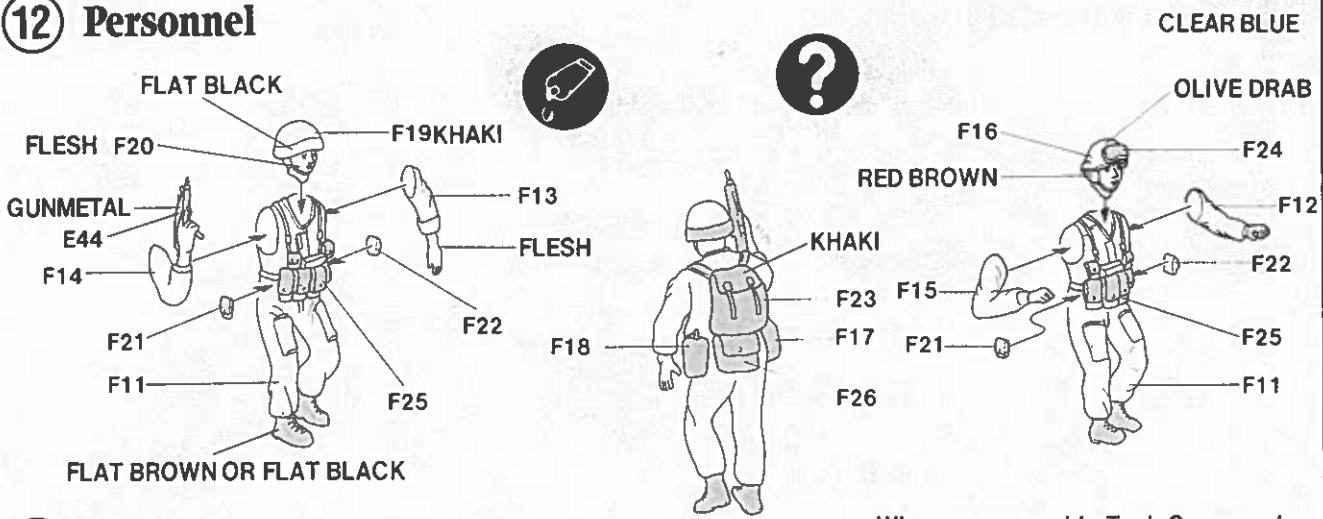

13 Hull Assembly

When you assemble Tank Commander. Do not fix the equipment of the back.

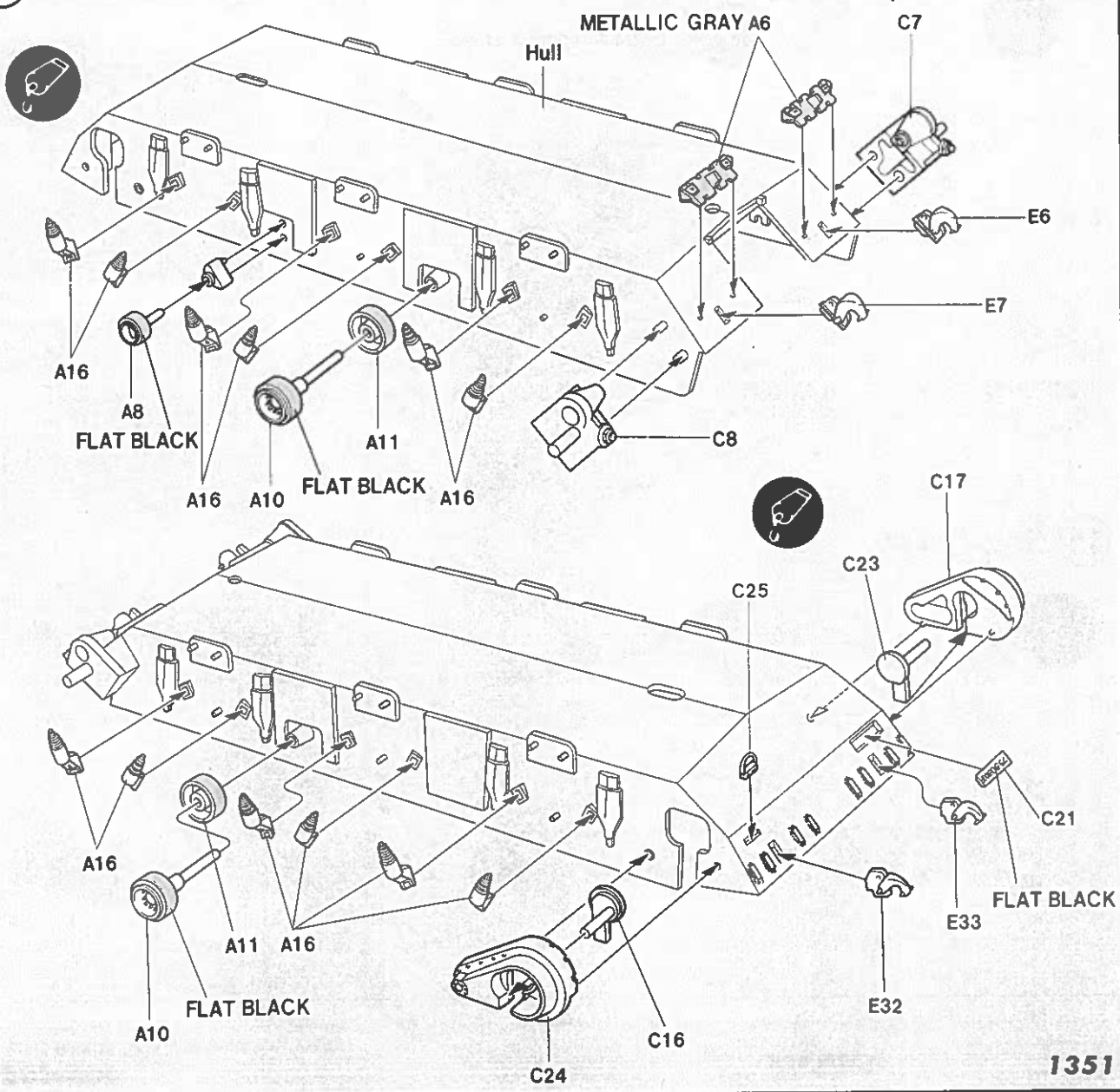

14 Rear Assembly

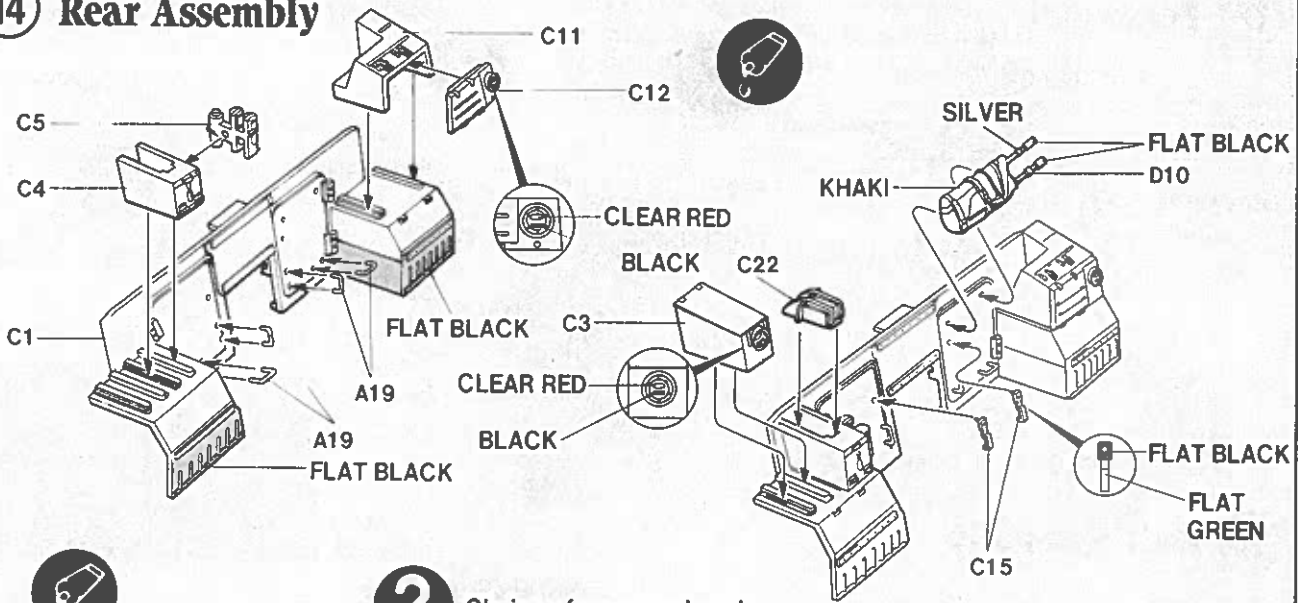

Choice of open or closed.

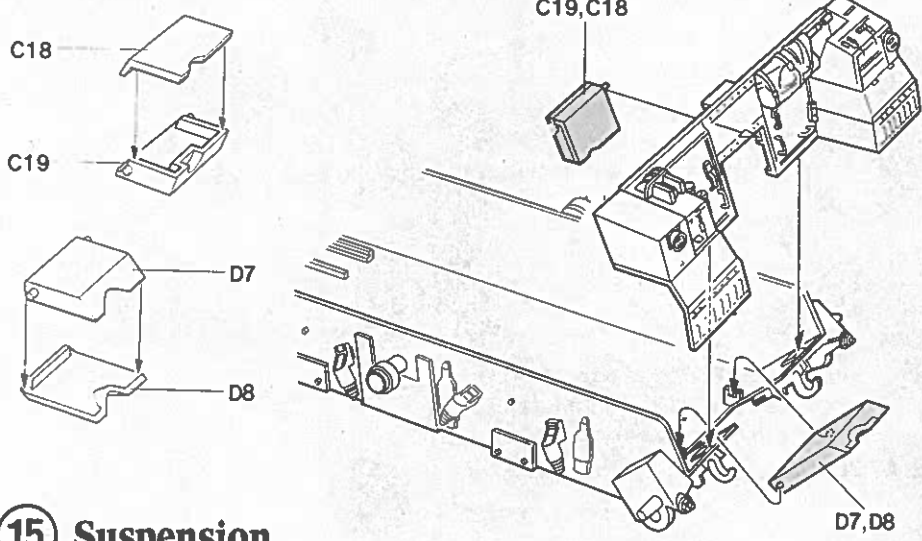

Rear Hatch

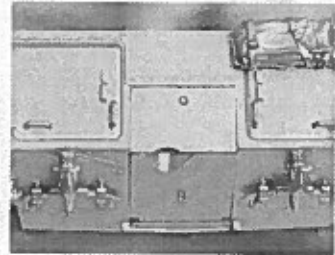

Closed

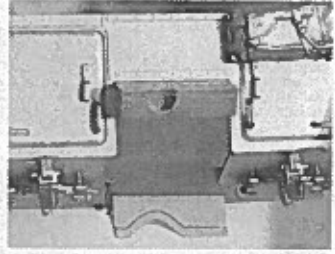

Open

15 Suspension

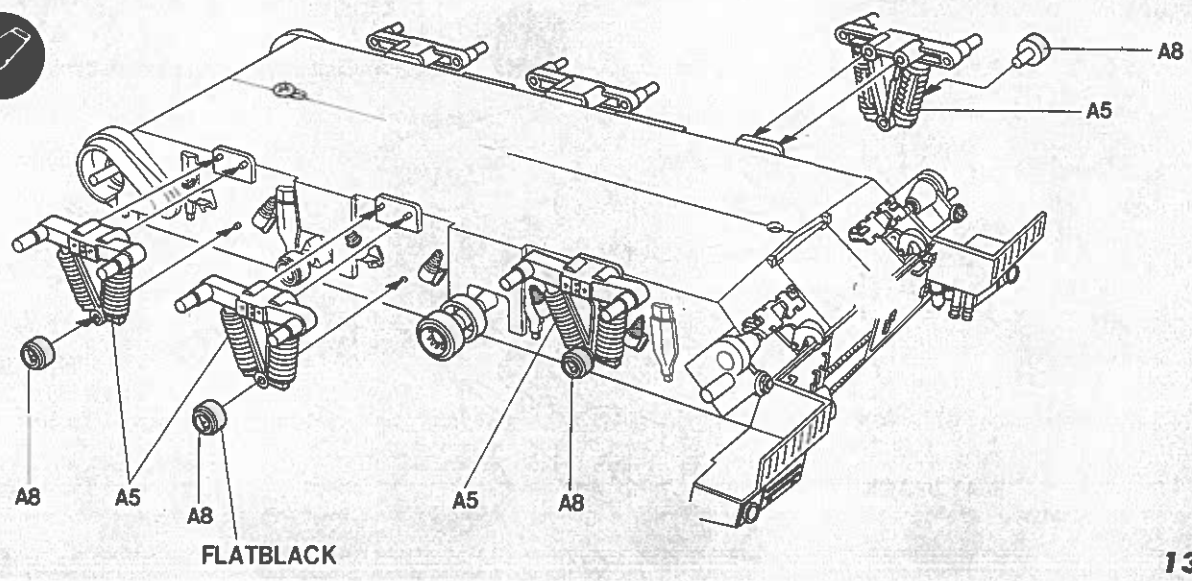

16 Wheel Attachment

Notice the position of the first road wheels.

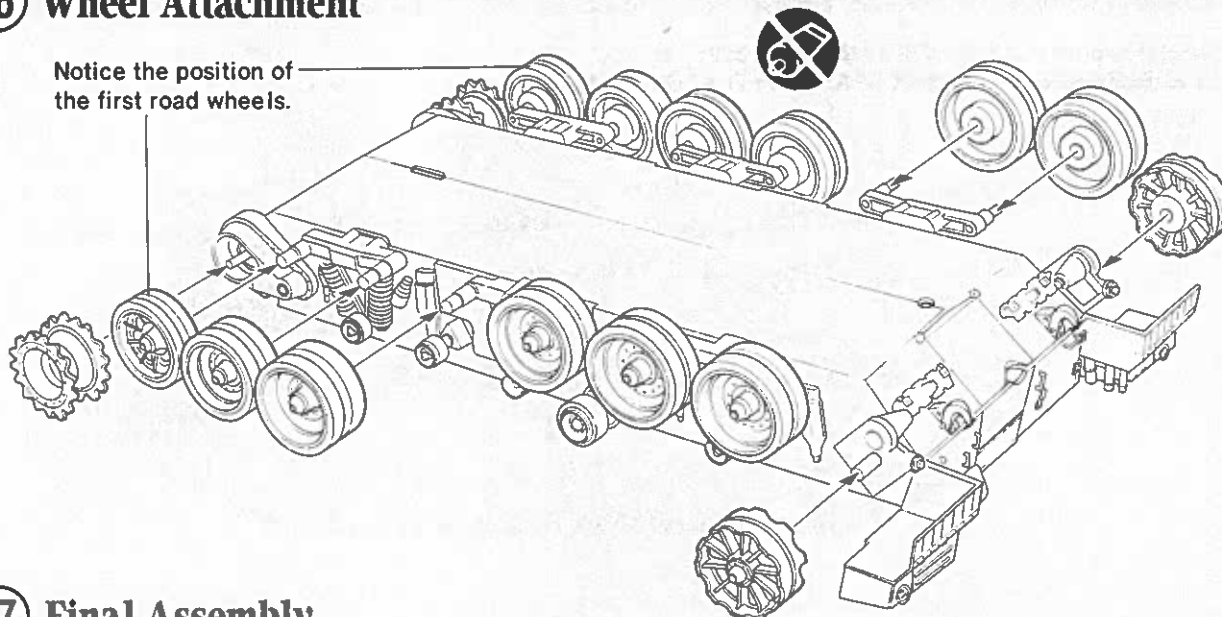

17 Final Assembly

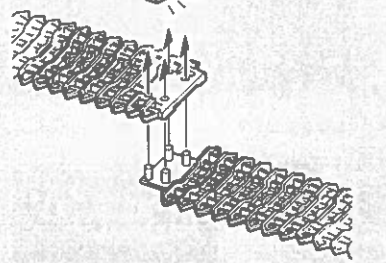
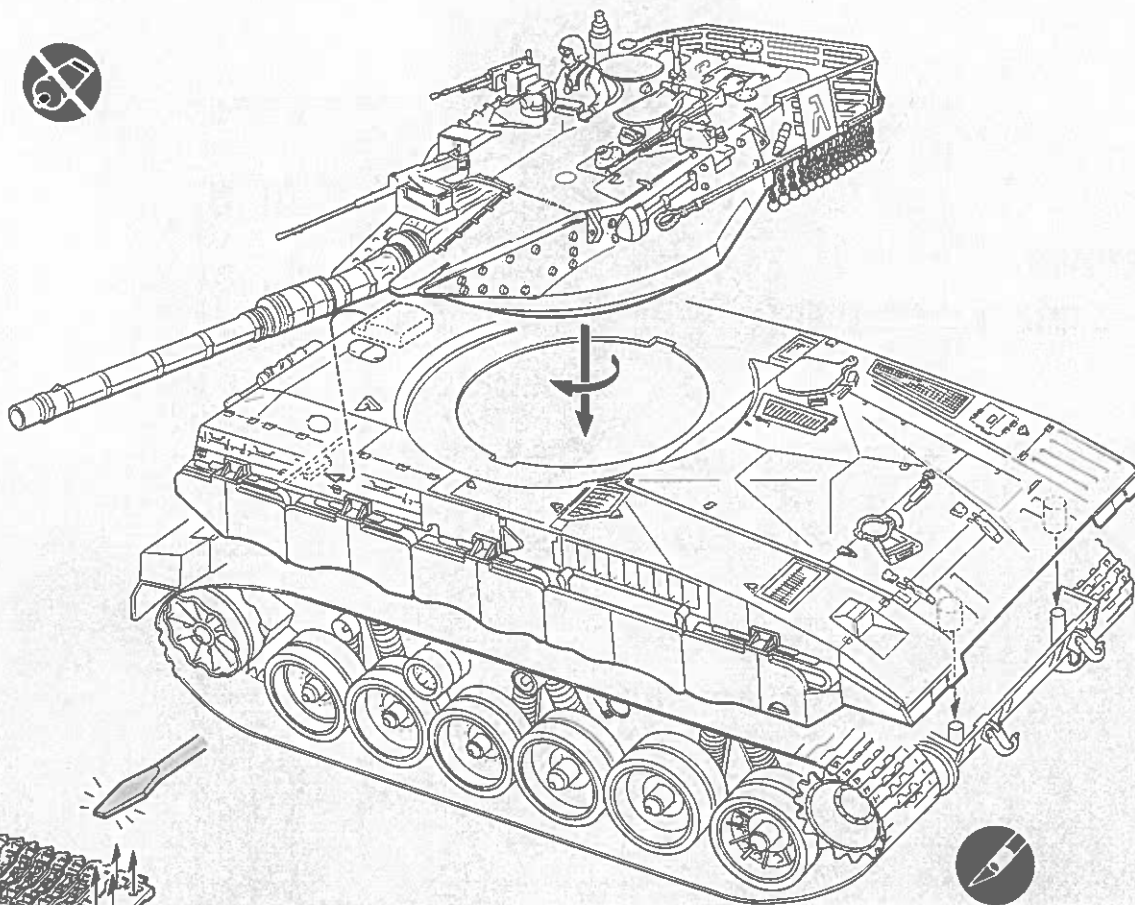

Melt treads together with a heated screwdriver.

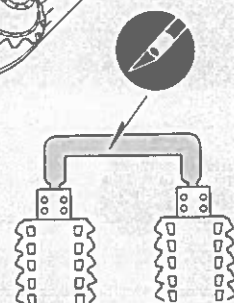

Painting and Decal Instructions

Tank is overall FLAT ARMOR SAND F.S. # 30277 or
FLAT BUFF 80%+FLAT DARK GRAY 10%+FLAT GREEN 10%

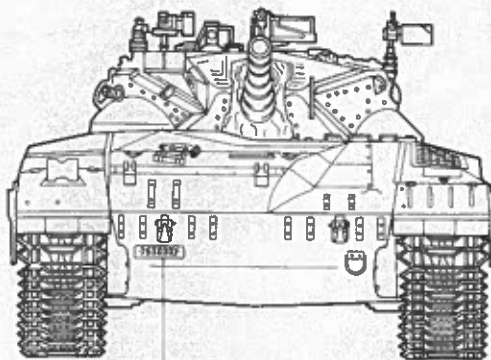
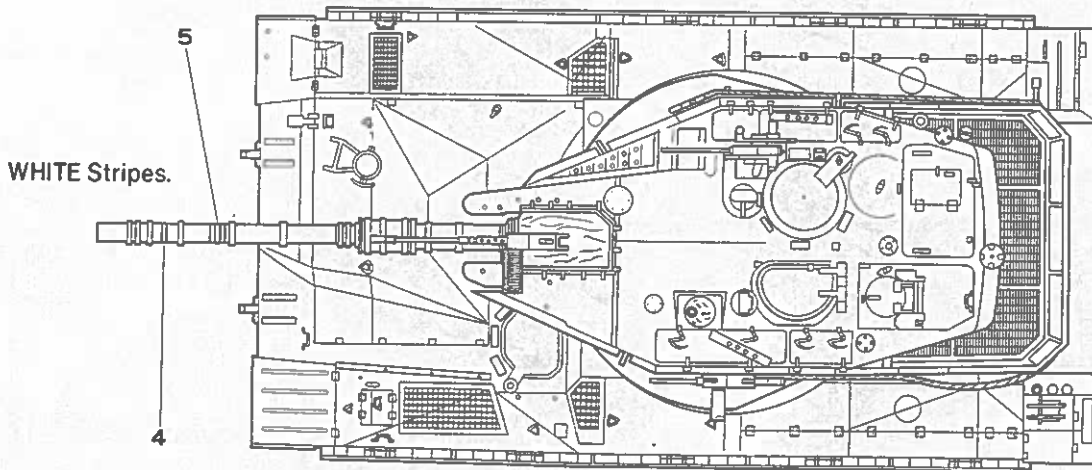
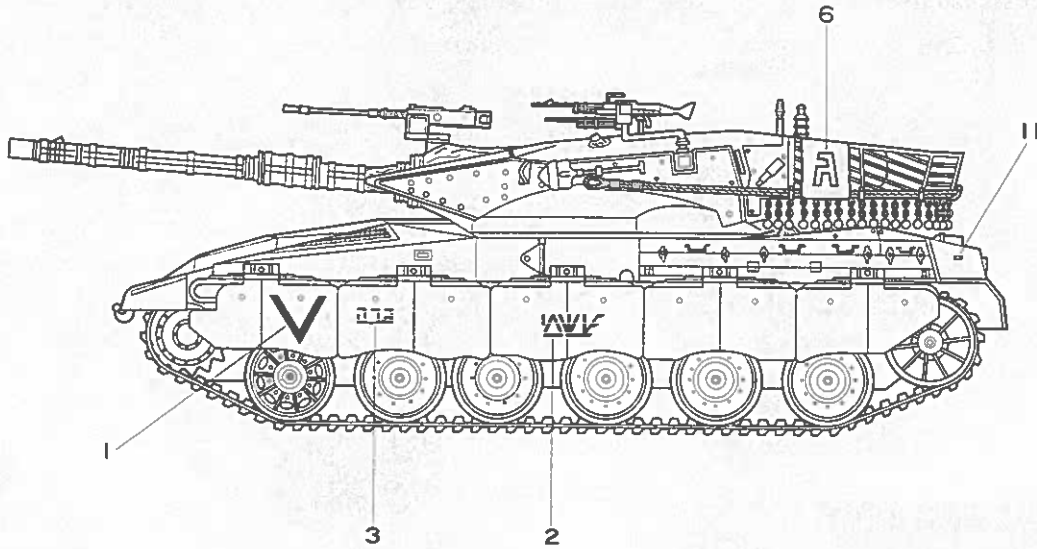

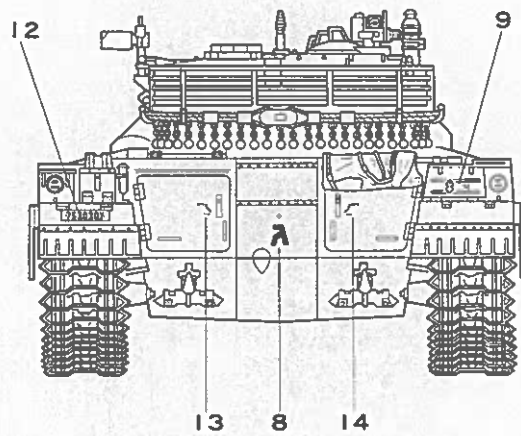
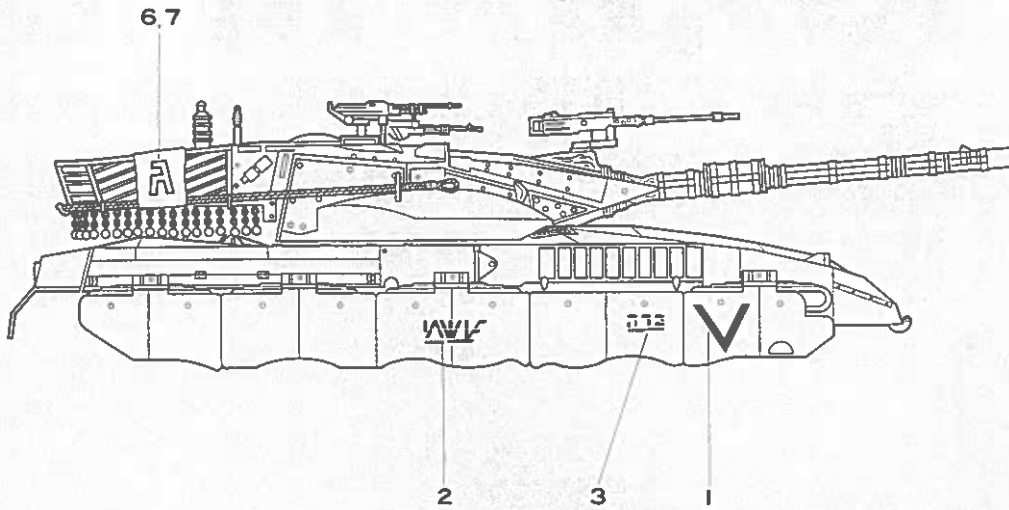

Cement Parts
Coller
Kleben
Pegar
Incollare
Colar
Kleven



DO NOT cement
Ne pas coller
Nicht kleben
No pegar
Non incollare
Nao colar
Niet kleven



Cut away
Couper
Scheden
Cortar
Tagliare
Cortar
Snijden



Optional parts
Choix
Auswahlmoglichkeit
Eleccion
Scelta
Opcao
Keuze



3

Repeat operation
Répéter l'opération
Vorgang wiederholen
Repitir la operación
Ripetere
Repitir a operação
Herhalen

Parts Locating Diagram

A × 2

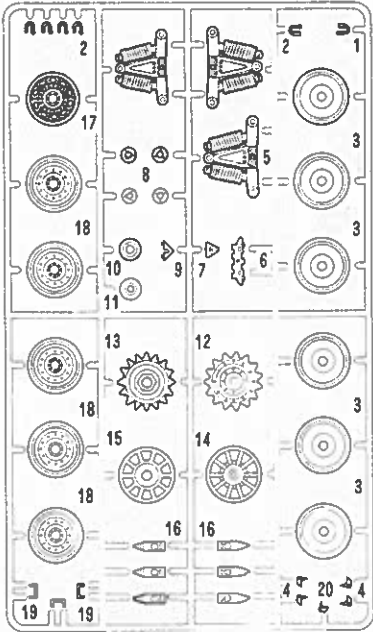

B

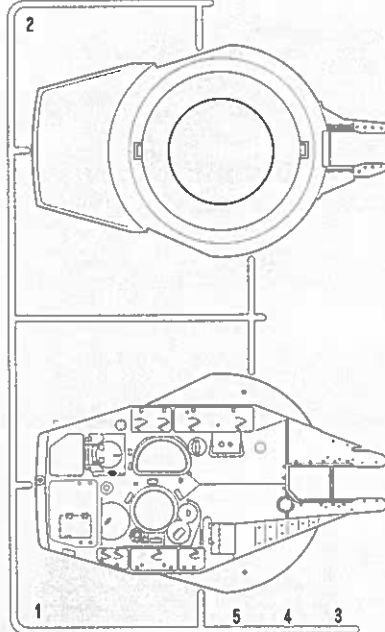

C

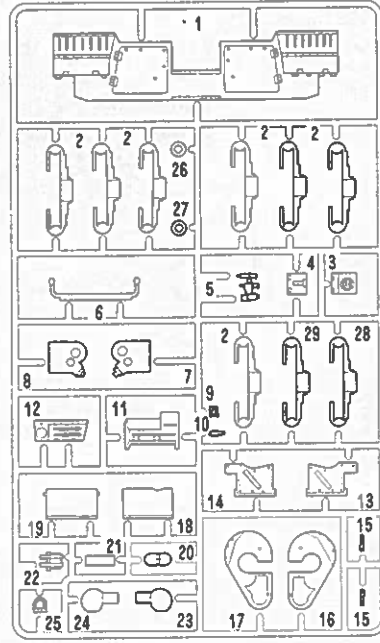

D

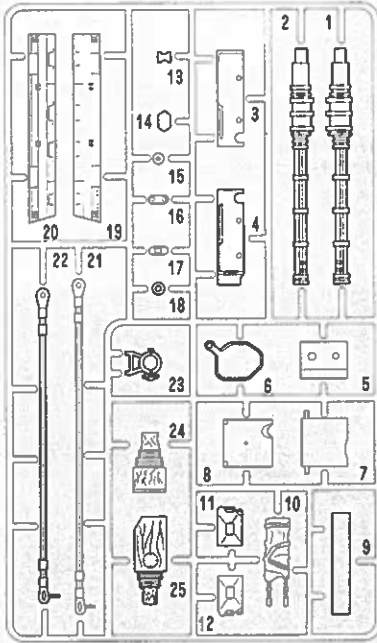

E

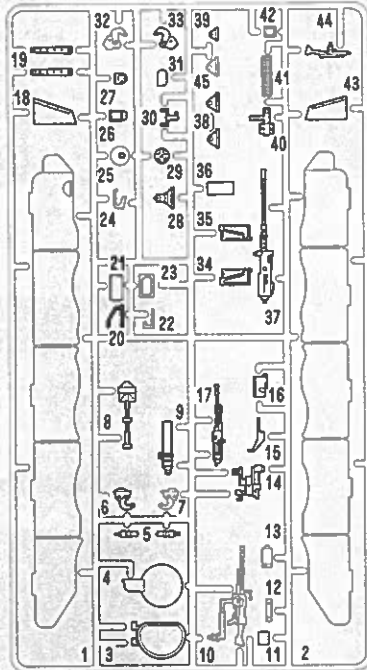

F

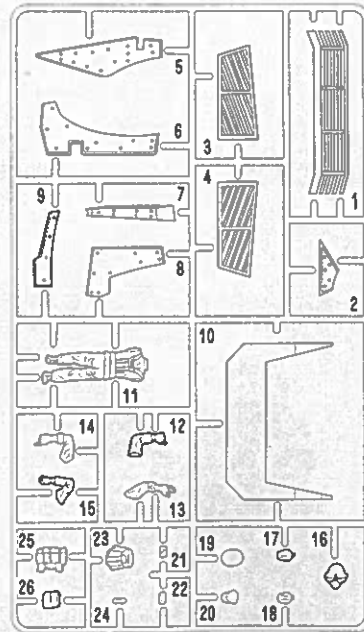

P.V.C. TIRES

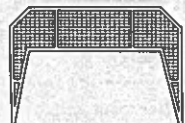
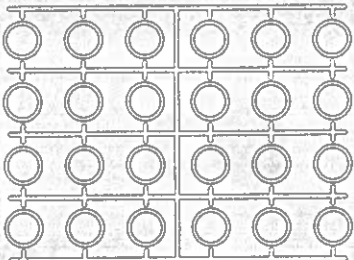

PHOTO ETCHED PART



WHITE METAL PART



POLY CAP

ACADEMY
HOBBY MODEL KITS