

Fw 190A-3

eduard

GERMAN WWII FIGHTER

1/48 SCALE PLASTIC KIT

ProfiPACK
edition

#82144



INTRO

The second half of the Second World War saw the Focke-Wulf Fw 190, in its various forms, emerge as the best of what was available to the Luftwaffe. The dedicated fighter version was a high performance, heavily armed machine. Its development had a precarious beginning, against a 1938 specification issued by the Technisches Amt, RLM. The first prototype took to the air on June 1st, 1939. After a series of improvements and even radical changes, the design culminated in the fall of 1940 in the pre-series version Fw 190A-0 to the tune of twenty-eight pieces. Six of these were retained by the test unit Erprobungsstaffel 190 at Rechlin, which was tasked with conducting service trials. These revealed a wide range of flaws to the point where the RLM halted further development. Despite this, on the basis of urgings from the test unit staff, the aircraft was not shelved. After a series of some fifty modifications, the RLM gave the go ahead for the Fw 190 to be taken into inventory of the Luftwaffe. In June 1941 the Luftwaffe accepted the first of 100 ordered Fw 190A-1s, armed with four 7.9 mm MG 17s. By September 1941 II./JG 26 was completely equipped with the type operating on the Western Front. November saw the production of the next version Fw 190A-2, powered by a BMW 801C-2, and armed with two 7.9 mm MG 17s and two MG 151s of 20 mm caliber in the wings. Part of this series received an additional pair of 20 mm MG FFs, thus attaining an armament standard of later types. A significant advancement to the design came in the spring 1942, when the BMW 801D-2 became available, whose installation gave birth to the Fw 190A-3. July saw the development of the improved A-4. Both were armed with what became the standard two fuselage mounted MG 17s, two wing mounted MG 151 cannons, and two MG FF cannons, placed inboard of the wheel wells. During 1942 production had intensified, and a production facility was set up under license at Fieseler. Thanks in part to this, production rose in 1942 to 1,878 units as opposed to 224 in 1941. Large-scale production of the A-5 was initiated in April 1943 with an identical wing to the A-4, but with a nose extension that would become standard on all subsequent Fw 190A versions up to the A-9, and also on the corresponding F types. July saw the development of a new, strengthened wing, which incorporated MG 151s instead of the MG FFs in the outer position. The adoption of this wing developed the A-6 version. Further changes developed the A-7, produced during the end of 1943. This version came about with the replacement of the fuselage mounted MG 17s with 13 mm MG 131s. Further improvements led to the Fw 190A-8, and this version became the most widely produced with some 6,655 units made. The most significant change to this variant was the installation of the GM-1 nitrous-oxide injection system, for temporary power boost in combat. A portion of A-8 production was built as the A-8/R2 and A-8/R8, armed with MK 108 cannon in the outer wing location, and with armoured slabs added to the cockpit sides and a modified canopy. The final production version of the BMW 801 powered fighter was the Fw 190A-9, equipped with the BMW 801TS of 2000 hp (1470 kW). There was a parallel development of these fighter optimized aircraft with a dedicated fighter-bomber version, the Fw 190F. These aircraft had reduced wing armament to two MG 151 cannons in the wing root position. The engine was optimized for low level operation, and the armament options varied to satisfy the ground attack role, including bombs of various weight classes and a variety of anti-tank rockets. This branched into the extended range Fw 190G version. Development of the throughbred fighter continued in the guise of the Fw 190D, which began to reach Luftwaffe units in the second half of 1944, and was the result of mounting an in-line Jumo 213A-1 engine into a modified Fw 190A-8 airframe. Although the Fw 190 never achieved the widespread usage of the competing Bf 109, its contribution to the German Air Force was certainly significant through the second half of WWII. Fw 190s saw service on the Western Front as well as in the East. As heavy fighters with imposing firepower, they found themselves integral components, from 1943 onwards, within the units tasked with the protection of the Reich from the ominous clouds of allied four-engined bombers. This is where the A-8 version was instrumental, along with its A-8/R2 armoured development. This version, with its firepower, was a very ominous and daunting foe for the bomber crews. From the second half of 1944, their danger was kept in check to a degree by escorting P-47s, and necessitated the development of the P-51 Mustang.

ATTENTION



UPOZORNĚNÍ



ACHTUNG



ATTENTION



注意



Carefully read instruction sheet before assembling. When you use glue or paint, do not use near open flame and use in well ventilated room. Keep out of reach of small children. Children must not be allowed to suck any part, or pull vinyl bag over the head.



Před započítím stavby si pečlivě prostudujte stavební návod. Při používání barev a lepidel pracujte v dobře větrané místnosti. Lepidla ani barvy nepoužívejte v blízkosti otevřeného ohně. Model není určen malým dětem, mohlo by dojít k požití drobných dílů.

INSTRUCTION SIGNS * INSTR. SYMBOL * INSTRUKTION SINNBILDEN * SYMBOLES * 記号の説明

OPTIONAL
VOLBABEND
OHNOUTOPEN HOLE
VYVRTAT OTVORSYMETRICAL ASSEMBLY
SYMETRICKÁ MONTÁŽREMOVE
ODŘÍZNOUTREVERSE SIDE
OTOČITAPPLY EDUARD MASK
AND PAINT
POUŽIT EDUARD MASK
NABARVIT

PARTS



DÍLY



TEILE



PIÈCES



部品

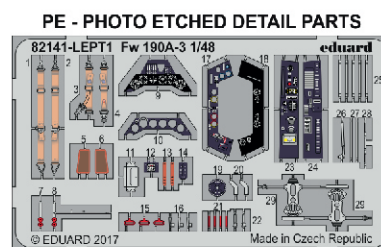
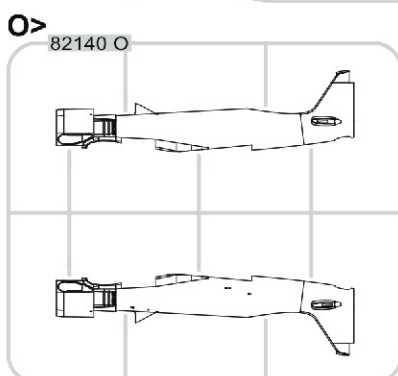
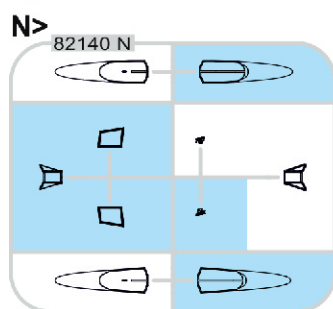
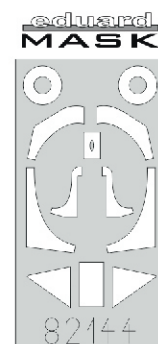
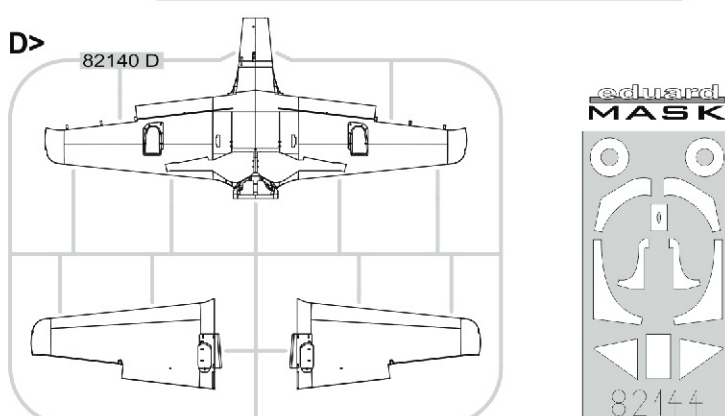
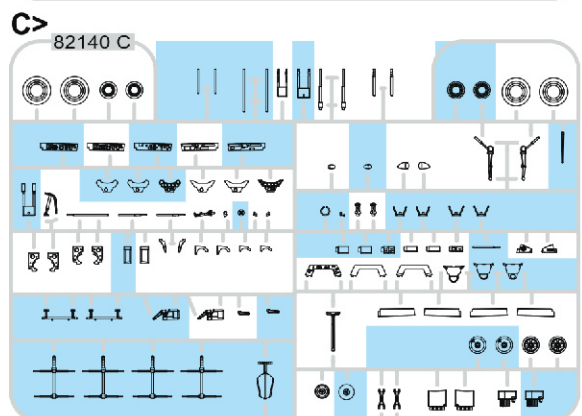
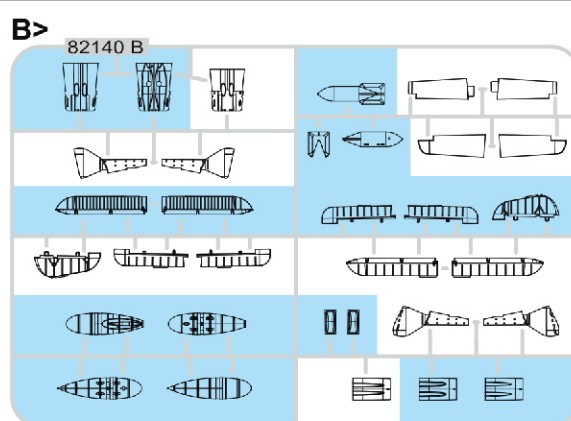
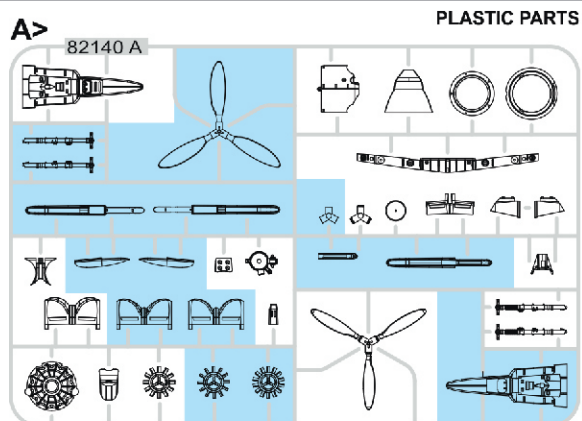

-Parts not for use. -Teile werden nicht verwendet. -Pièces à ne pas utiliser. -Tyto díly nepoužívejte při stavbě. - 使用しない部品

COLOURS



BARVY



FARBEN



PEINTURE



色

GSI Creos (GUNZE)		MISSION MODELS	
AQUEOUS	Mr.COLOR	PAINTS	
H1	C1	MMP-001	WHITE
H2	C2	MMP-047	BLACK
H11	C62	MMP-001	FLAT WHITE
H12	C33	MMP-047	FLAT BLACK
H24	C58		ORANGE YELLOW
H33	C81		RUSSET
H47	C41	MMP-012	RED BROWN
H64	C17	MMP-087	RLM71 DARK GREEN
H65	C18	MMP-088	RLM70 BLACK GREEN
H68	C36	MMP-049	RLM74 DARK GRAY
H69	C37	MMP-050	RLM75 GRAY
H70	C60	MMP-056	RLM02 GRAY

GSI Creos (GUNZE)		MISSION MODELS	
AQUEOUS	Mr.COLOR	PAINTS	
H77	C137	MMP-040	TIRE BLACK
H90	C47		CLEAR RED
H94	C138		CLEAR GREEN
H413	C113	MMP-090	RLM04 YELLOW
H414	C114	MMP-003	RLM23 RED
H416	C116	MMP-089	RLM66 BLACK GRAY
H417	C117	MMP-051	RLM76 LIGHT BLUE
Mr.METAL COLOR		METALLICS	
MC213		MMM-008	STEEL
MC214		MMM-001	DARK IRON
Mr.COLOR SUPER METALLIC		METALLICS	
SM06		MMC-001	CHROME SILVER

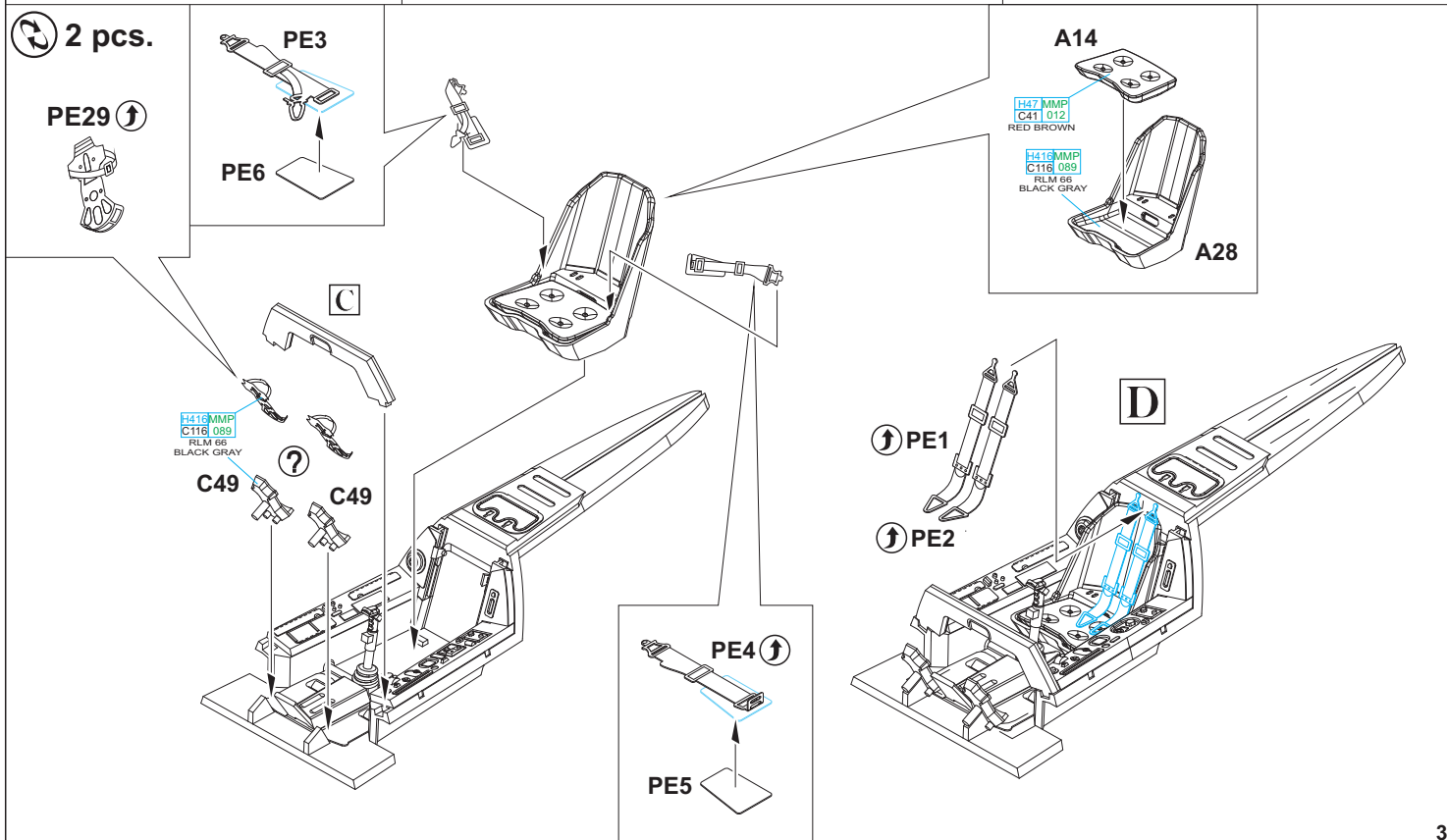
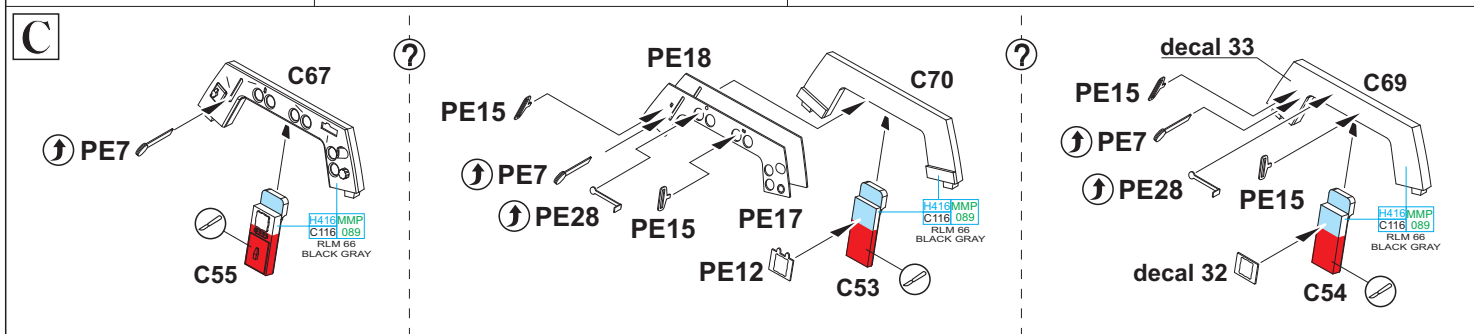
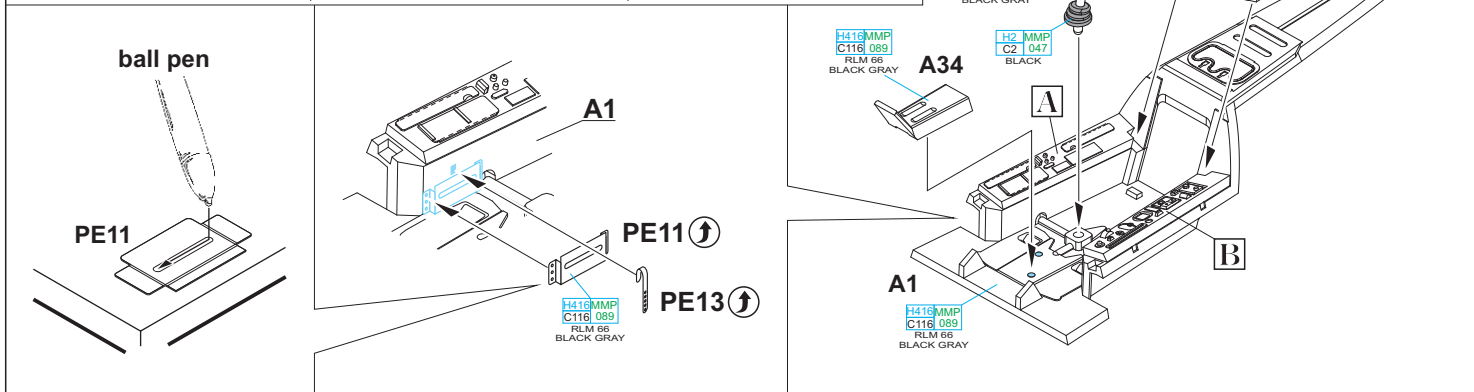
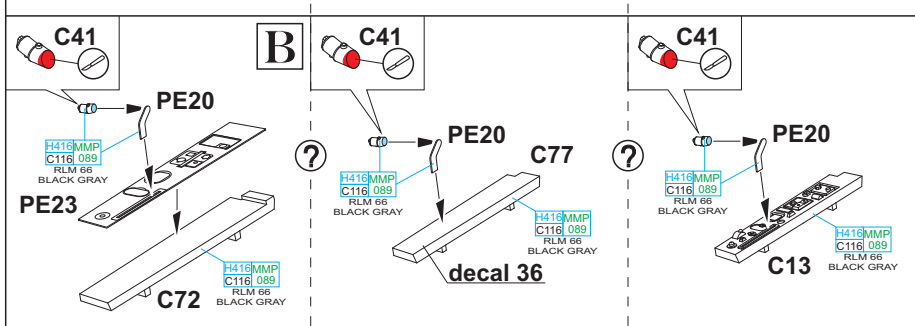
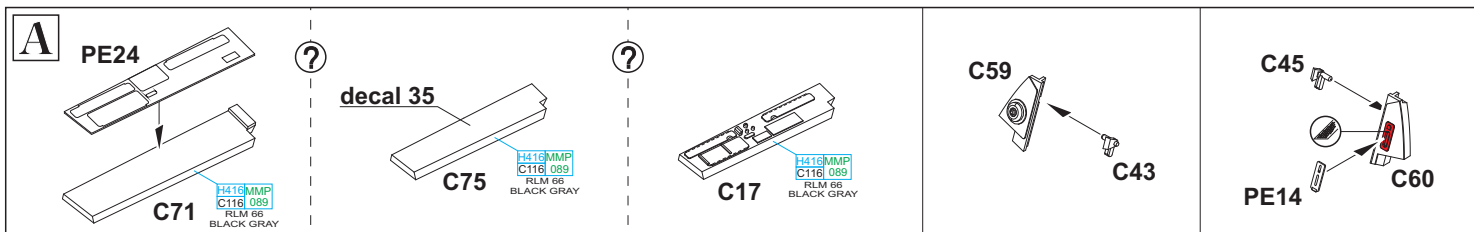

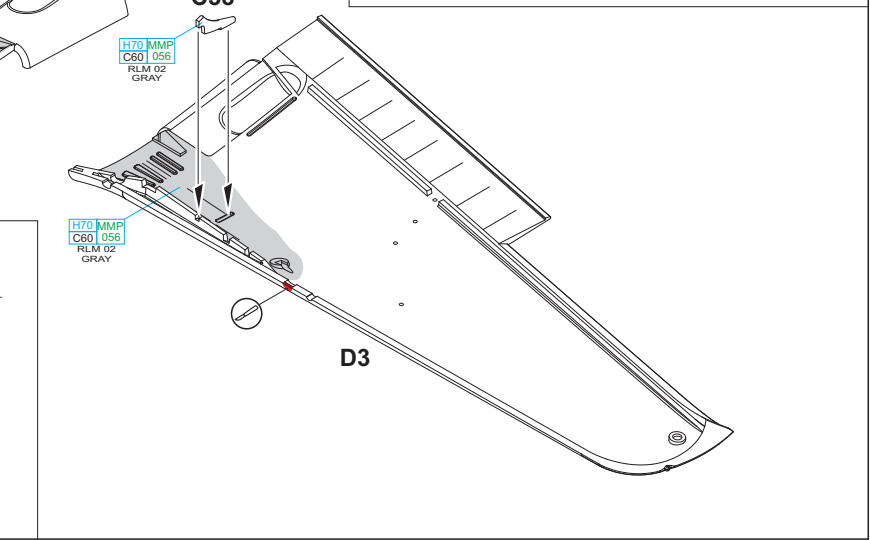
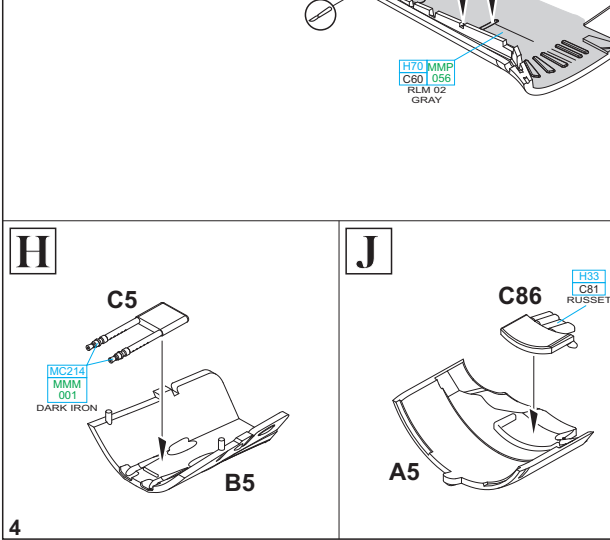
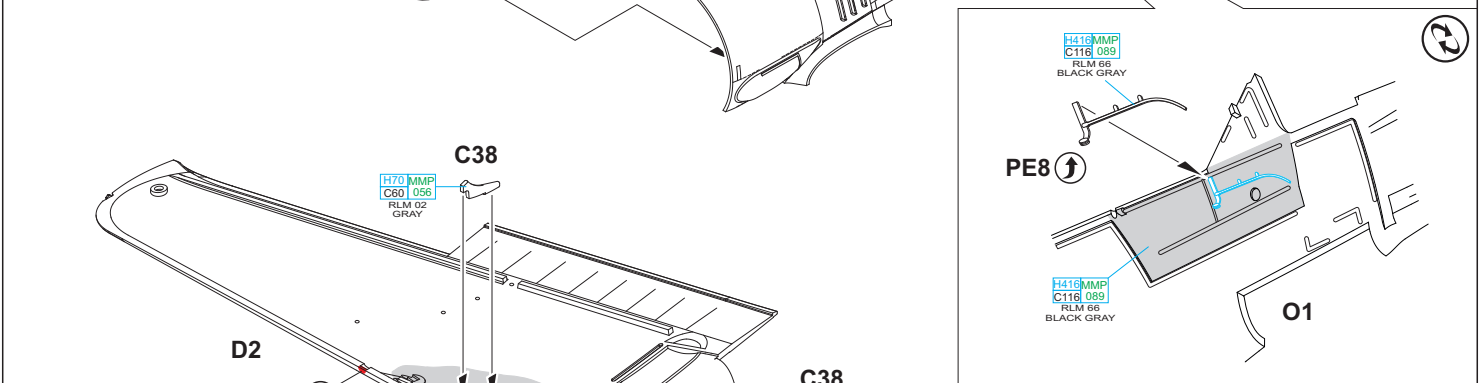
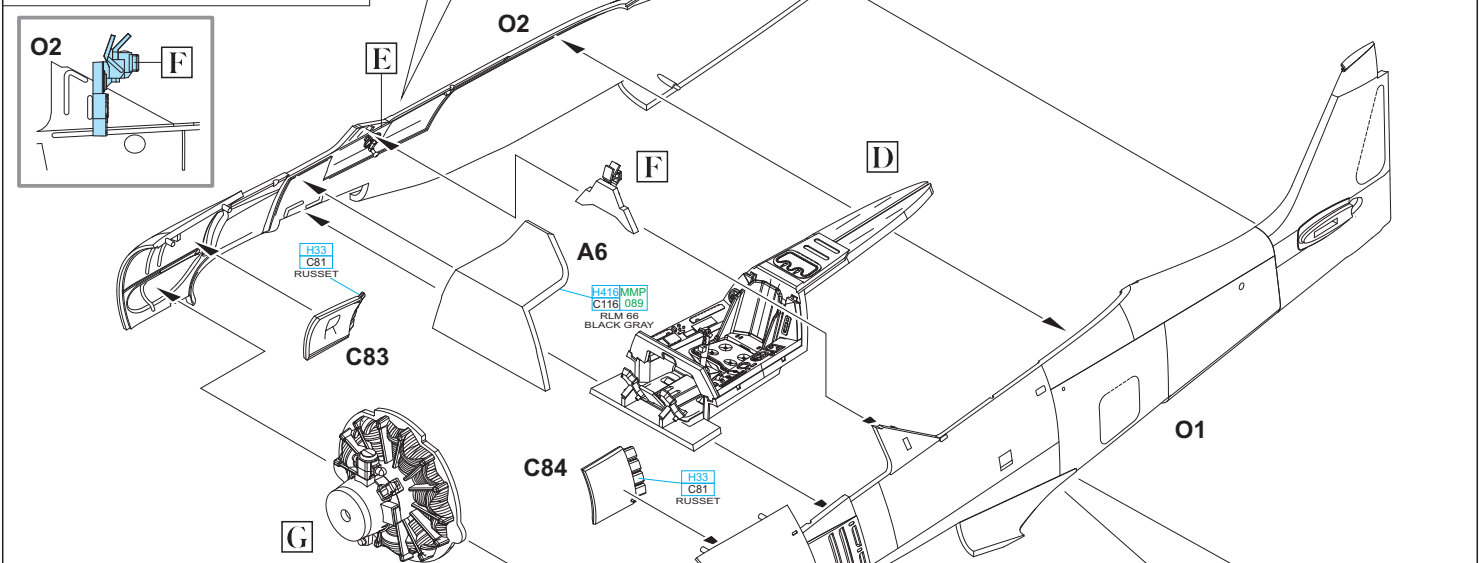
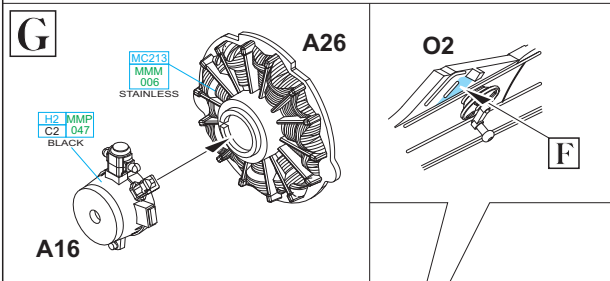
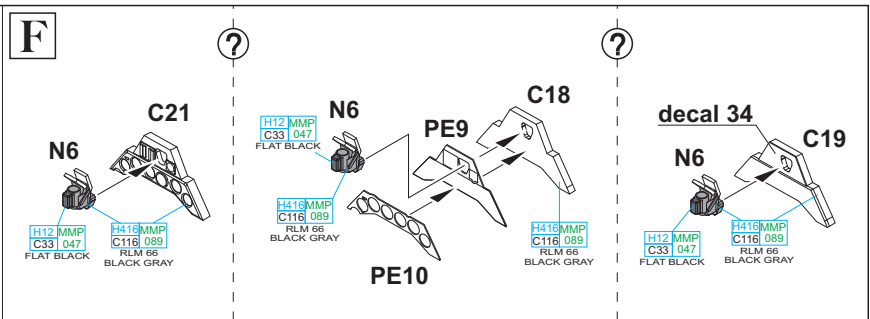
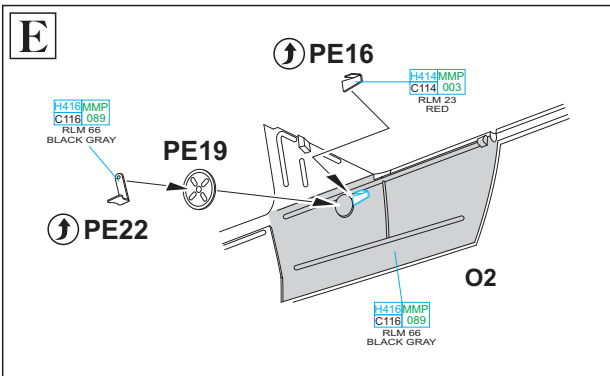

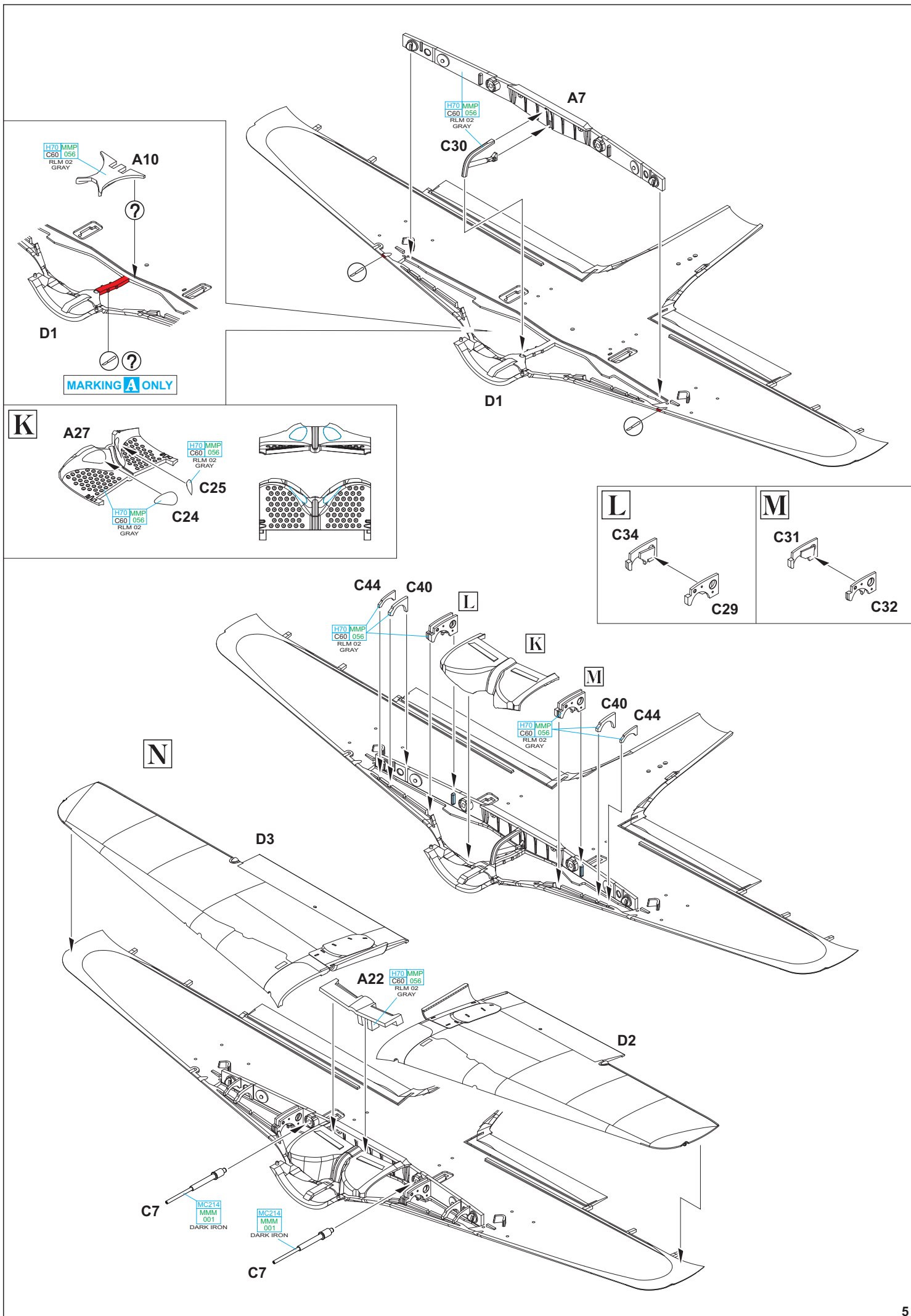

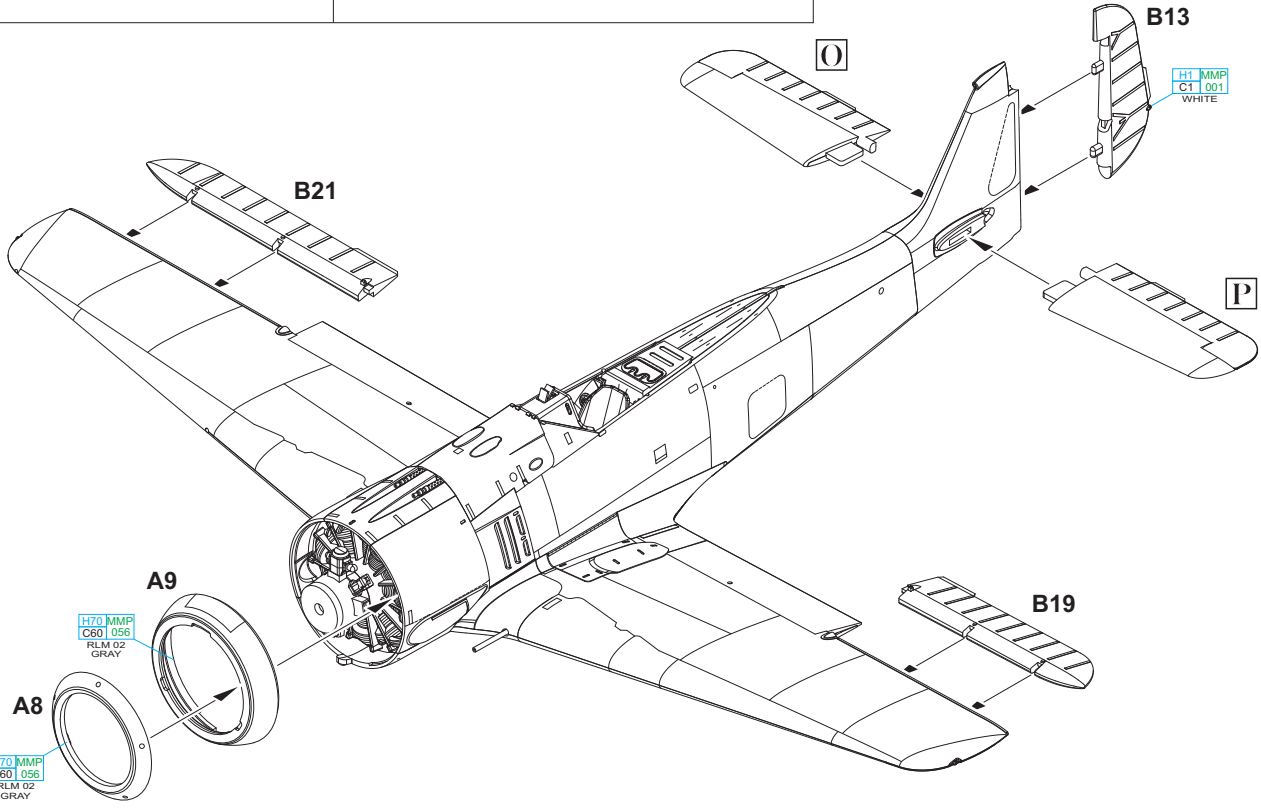
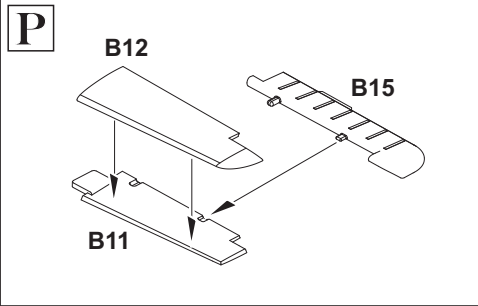
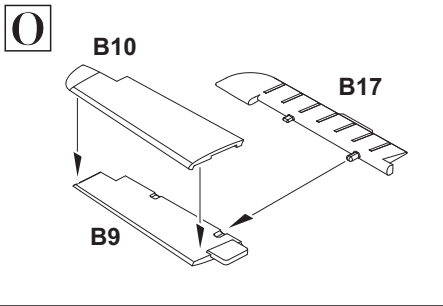
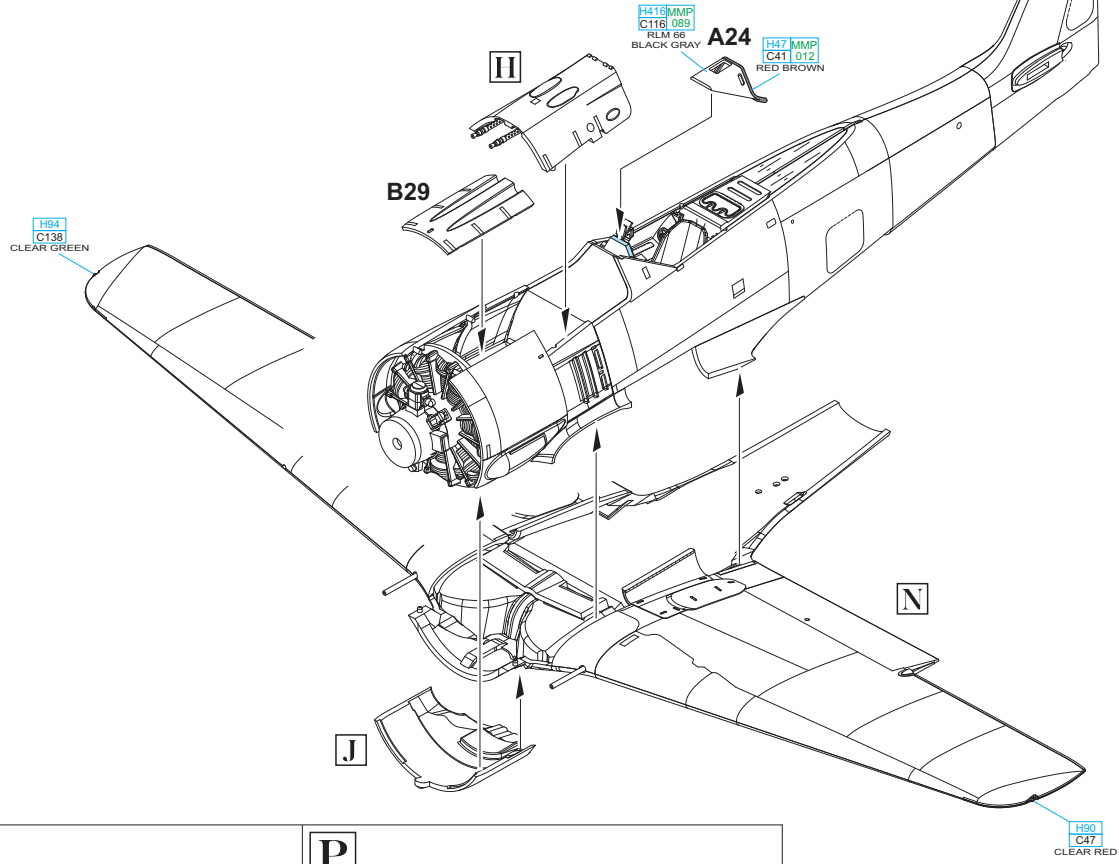
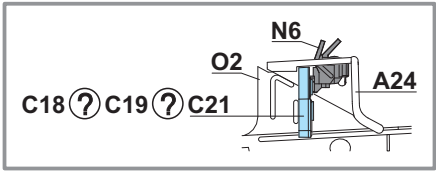

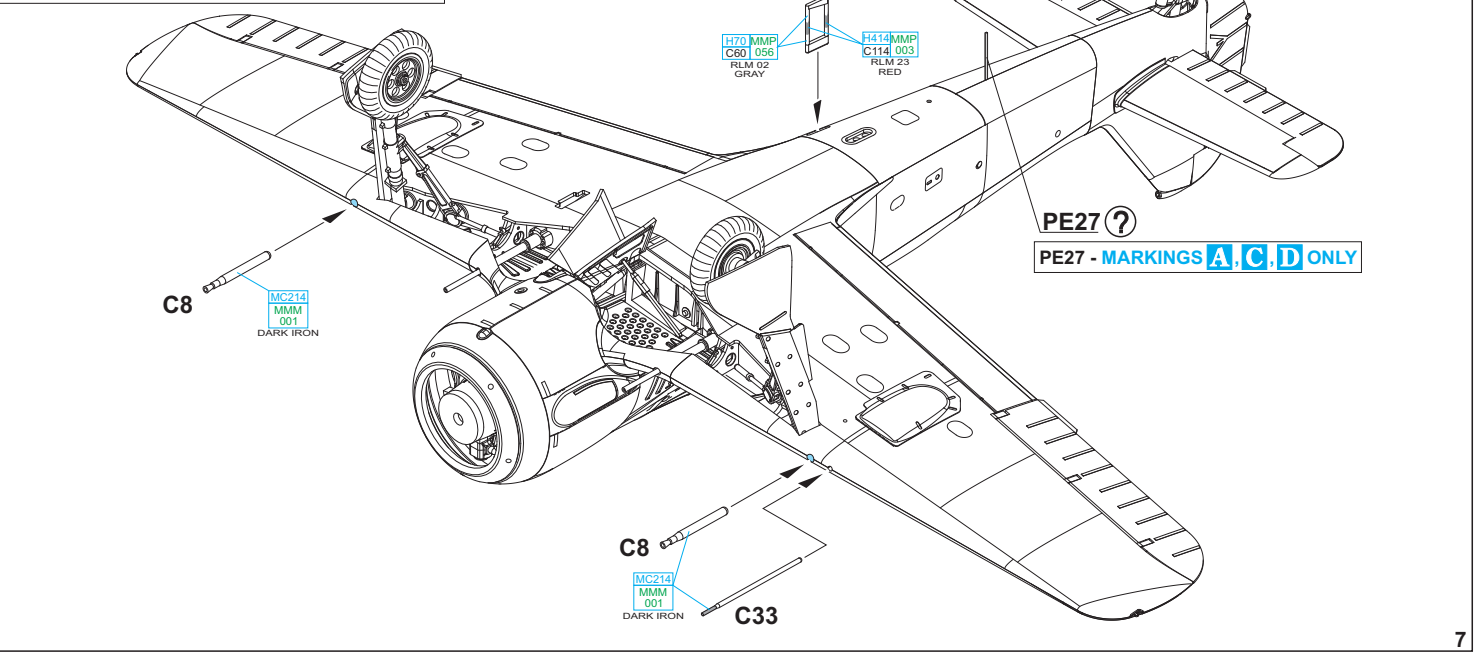
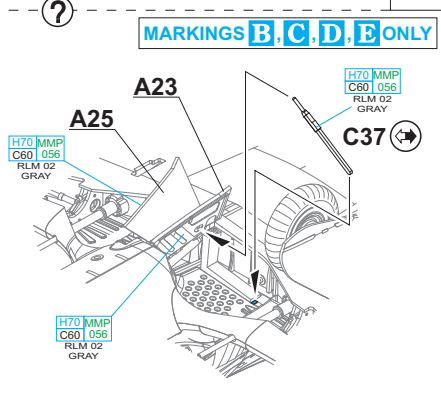
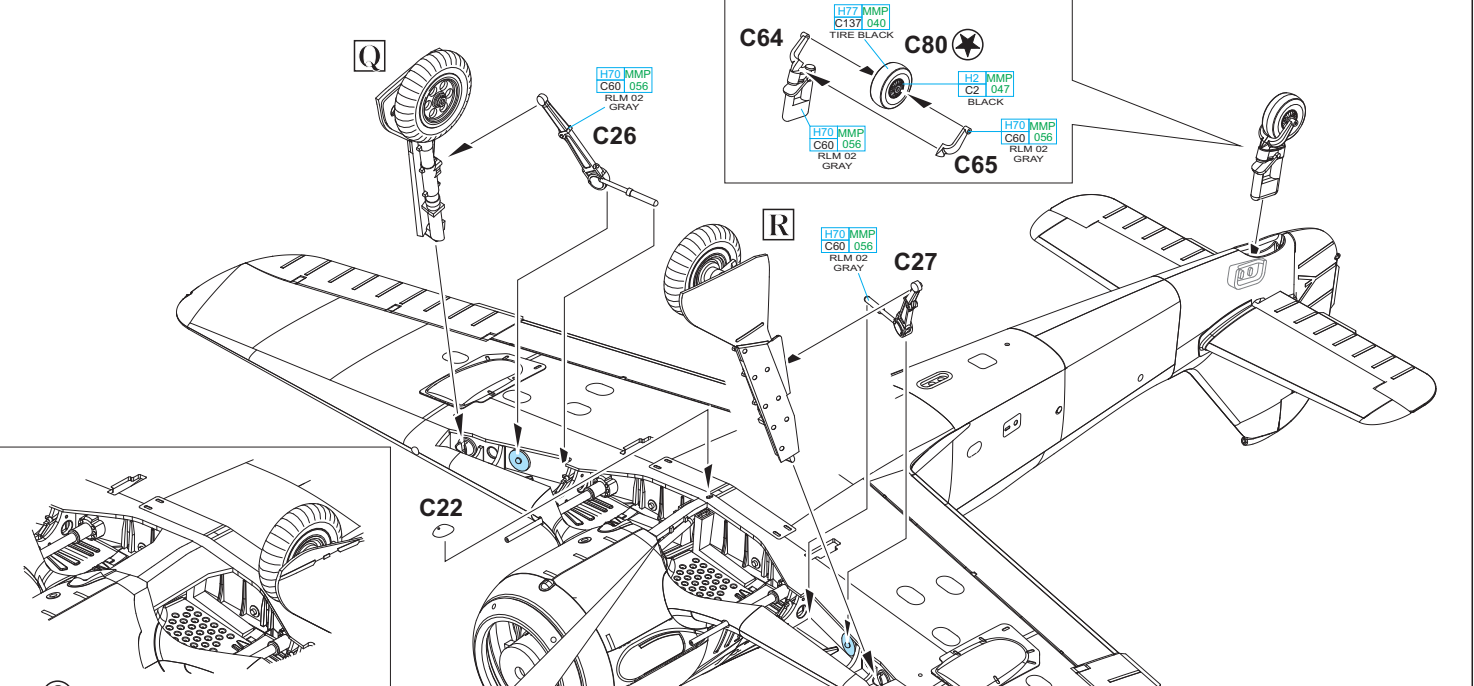
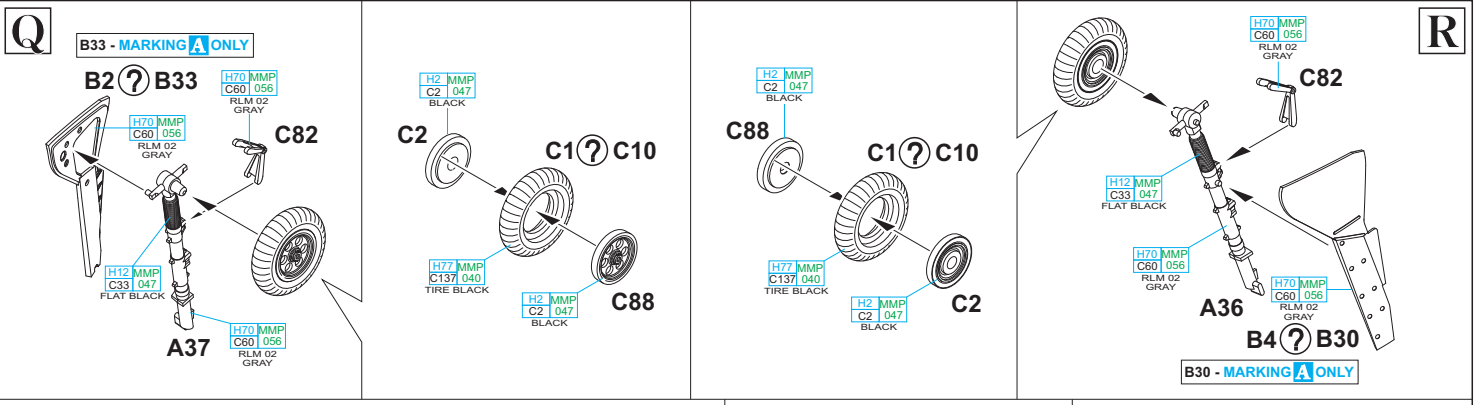

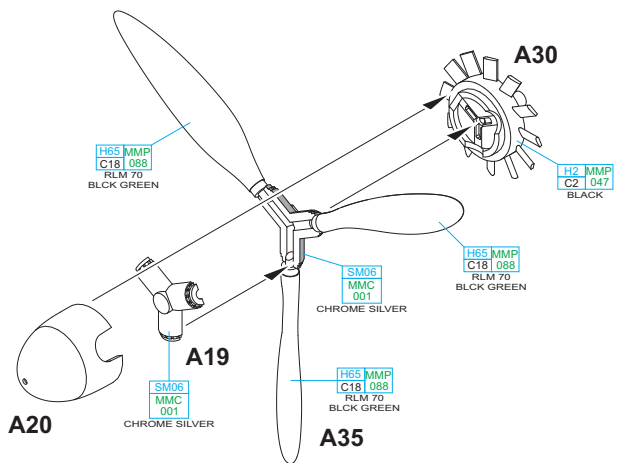
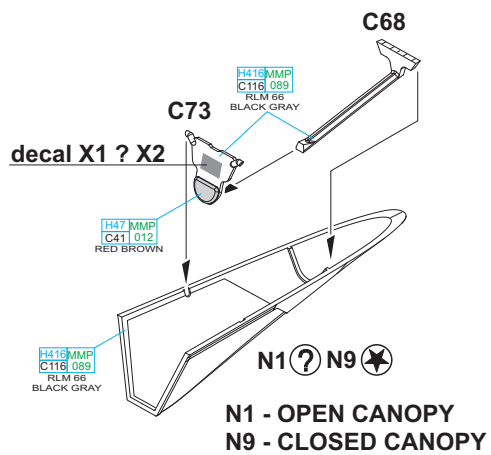
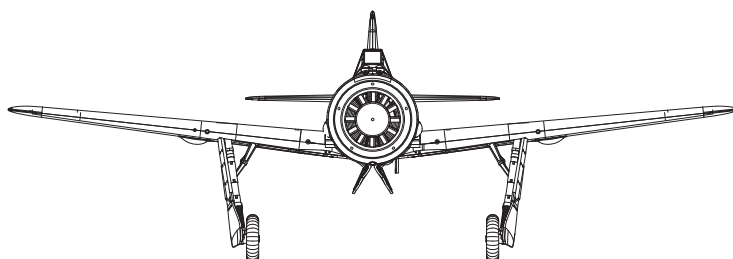
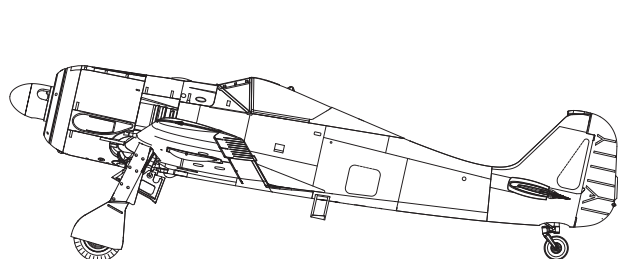
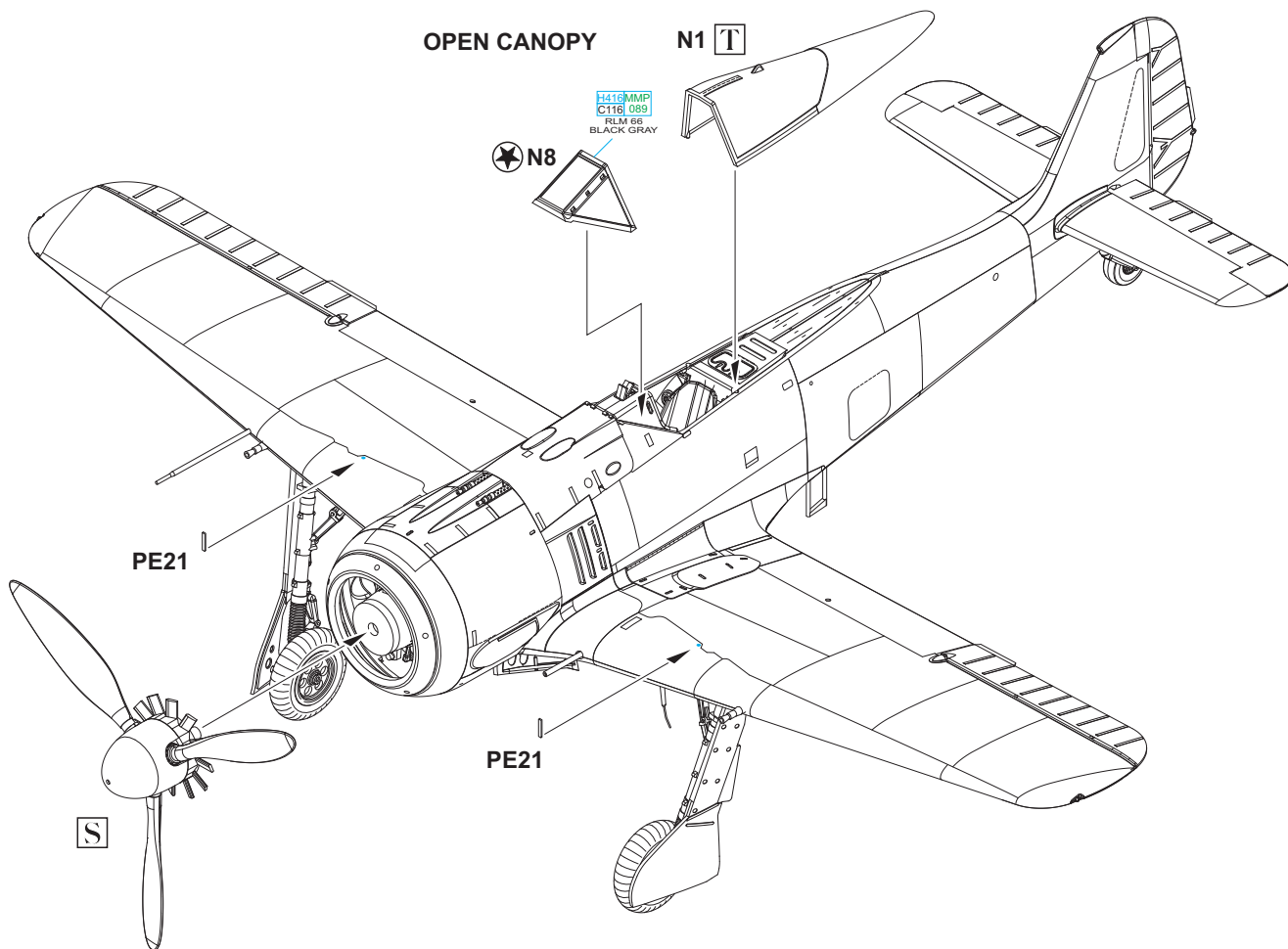
S**T****OPEN CANOPY****N1 T**

CLOSED CANOPY

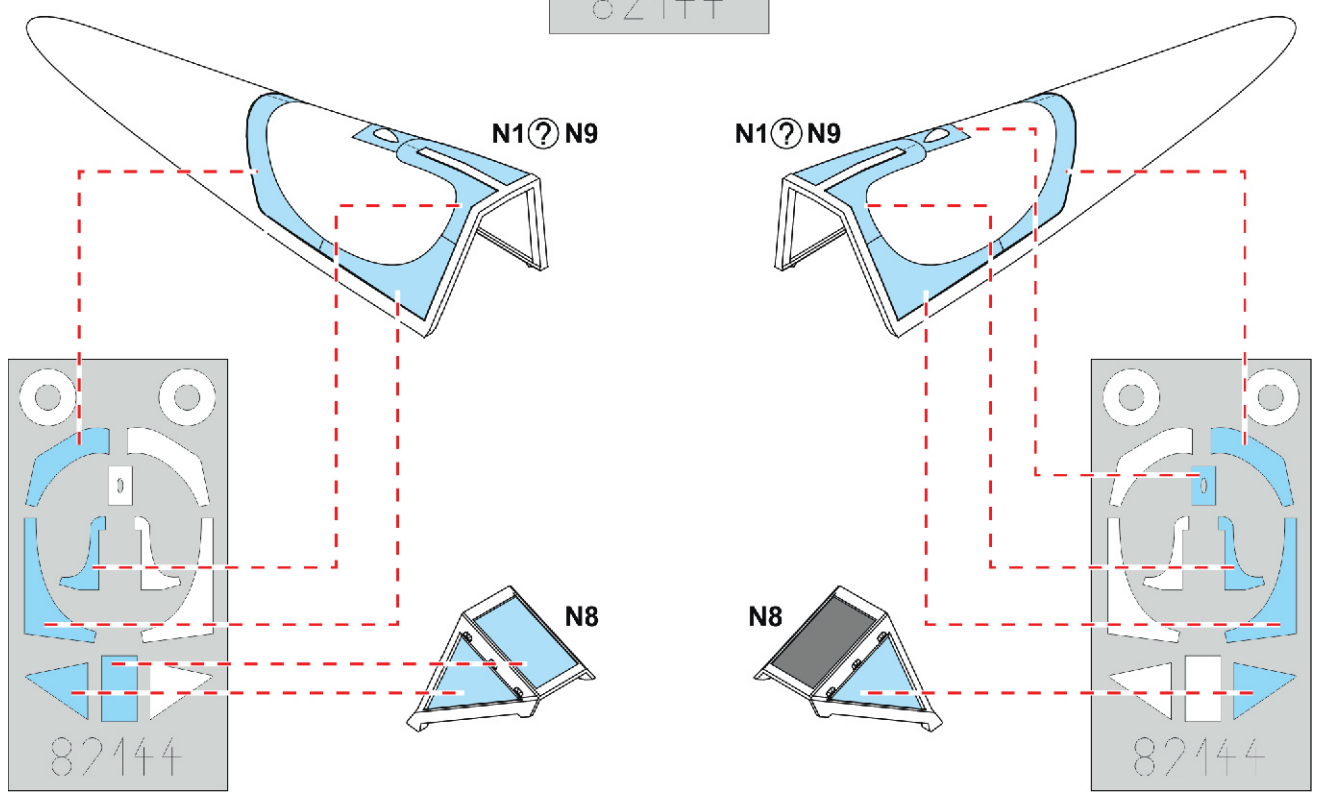
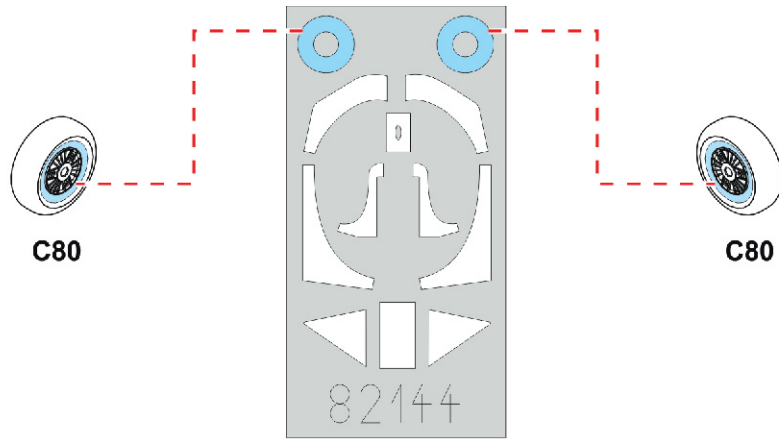
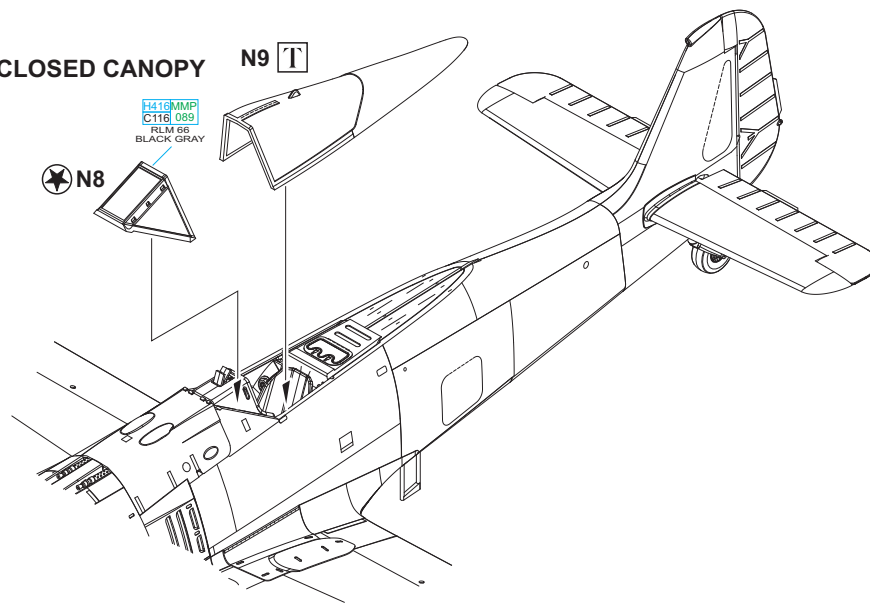

A W. Nr. 432, flown by Oblt. Erich Rudorffer, CO of 6./JG 2, Beaumont-le-Roger, France, August 1942

A native of Saxony, Erich Rudorffer, served in the Luftwaffe from April 16th, 1936, first starting out as a mechanic. In October 1938, he entered pilot training, and on its completion on January 8th, 1940, he was assigned to JG 2 with which he would see combat in the French campaign and over Great Britain. On November 11th, 1942, he was made CO of 6./JG 2, with which he was transferred to North Africa but found himself back over the Channel by March 1943. In May of the same year, Rudorffer took command of the entire II. Gruppe JG 2. When on July 30th, 1943 Hptm. Heinrich Jung commanding II./JG 51 was killed on the Eastern Front, his duties were taken over by Erich Rudorffer. With this unit, Rudorffer would see his greatest number of kills. On January 15th, 1945 he was made CO of I./JG 7, armed with the Messerschmitt Me 262 and flying this type he would gain twelve kills. His total count came to 224, and for his success he was awarded the Knight's Cross with Oak Leaves and Swords. After the war he served as a transport pilot in Australia and later with Pan Am. Erich Rudorffer died in April 2016. With the aircraft illustrated, Erich Rudorffer shot down two Spitfires during the operation over Dieppe and the Allied 'Operation Jubilee' The rudder shows Rudorffer's score up to August 19th, 1942..

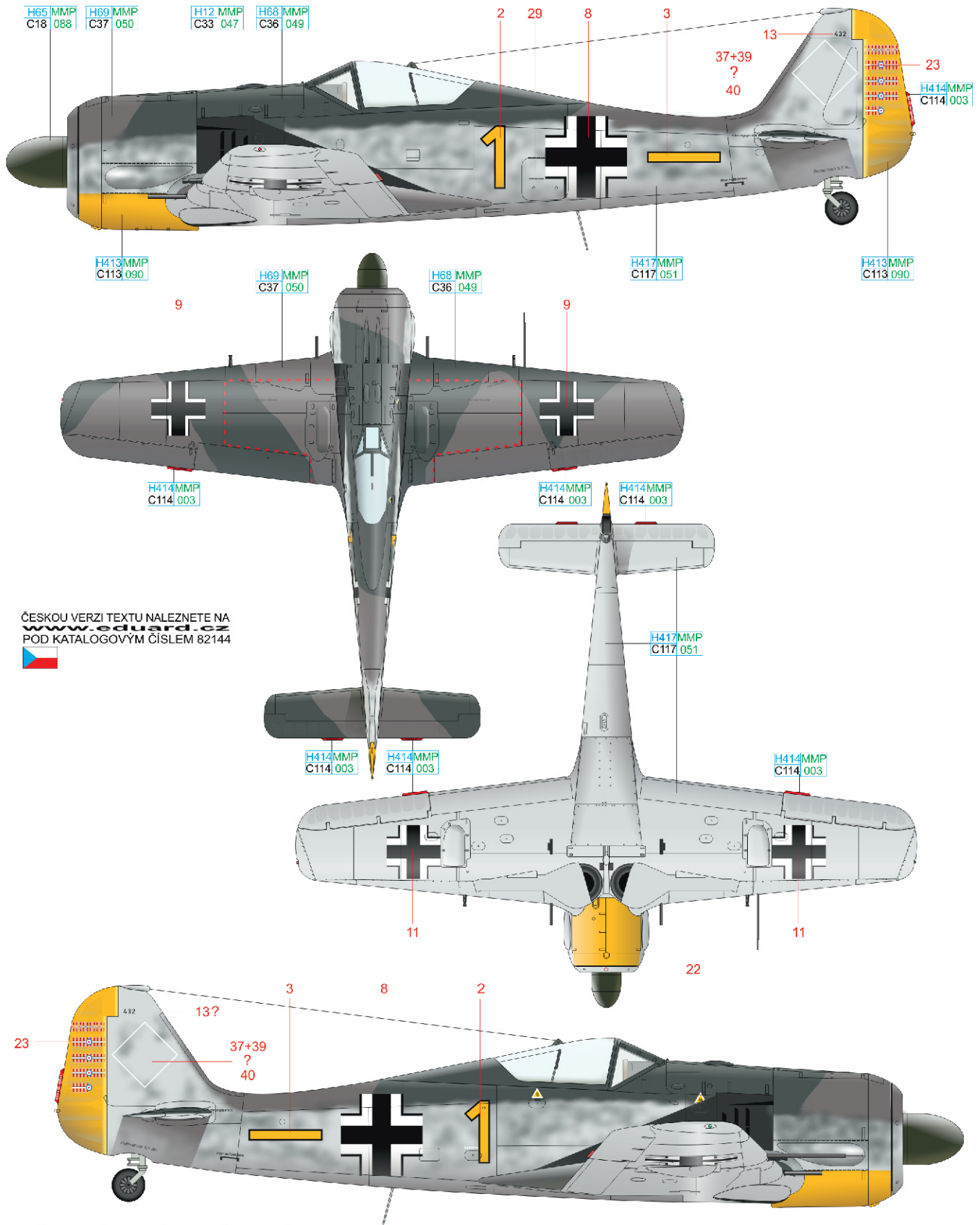

ČESKOU VERZI TEXTU NALEZNETE NA www.eduard.cz POD KATALOGOVÝM ČÍSLEM 82144



RLM 70	H65 MMP C18 088	RLM 04	H413 MMP C113 090	RLM 23	H414 MMP C114 003
RLM 74	H68 MMP C36 049	RLM 75	H69 MMP C37 050	RLM 76	H417 MMP C117 051
				BLACK	H12 MMP C33 047

B W. Nr. 418, flown by Oblt. Robert Olejnik, CO of 4./JG 1, Woensdrecht, the Netherlands, June 1942

Twenty-two-year-old native of Essen Robert Olejnik received his commercial pilot's licence in October 1933 and in March 1935, he joined the Luftwaffe and served as an instructor. After being assigned to combat units, he served with JG 3, with which he saw action in the French campaign and the Battle of Britain. Later, as Commanding Officer of 1./JG 3, he saw combat on the Eastern Front. On July 30th, 1941, he was awarded the Knight's Cross after achieving 32 kills. From September 1941 1./JG 3 served in the Netherlands, where the unit would be redesignated as II./JG 1 on January 15th, 1942. Olejnik served as the CO of its 4th Staffel and from July 26th, 1943 the entire III. Gruppe JG 1. In October 1943, he left JG 1 and served with units equipped with the rocket powered Me 163. He died on October 29th, 1988 in Munich. White 7, with which Robert Olejnik flew while with JG 1, was camouflaged in RLM 74/75/76. The engine cowl bears the unit marking of 4./JG 1, a mythical creature called the Tatzelwurm, rendered in white.

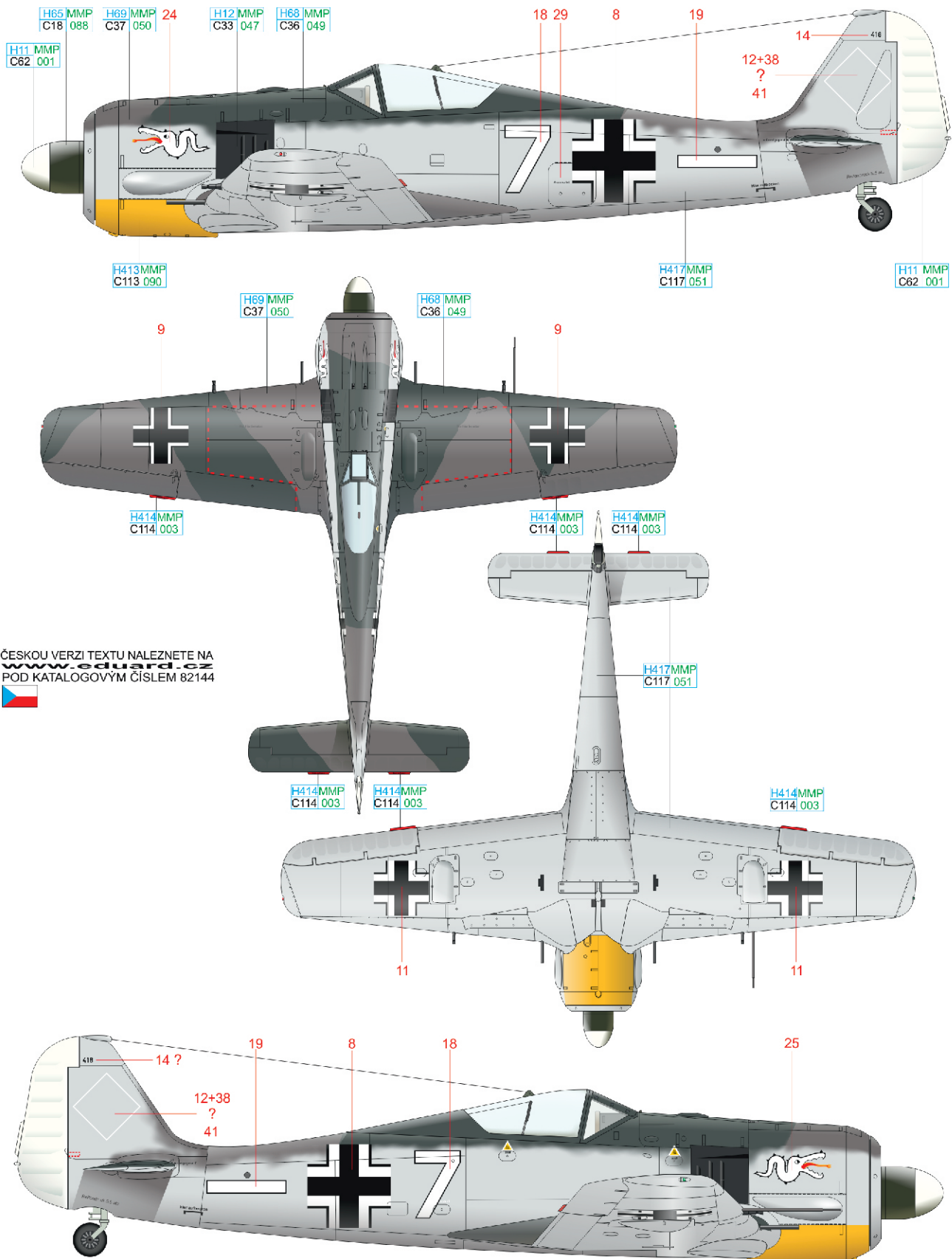

ČESKOU VERZI TEXTU NALEZNETE NA www.eduard.cz POD KATALOGOVÝM ČÍSLEM 82144



RLM 70	H65 MMP C18 088	RLM 04	H413 MMP C113 090	BLACK	H12 MMP C33 047
RLM 74	H68 MMP C36 049	RLM 75	H69 MMP C37 050	RLM 76	H417 MMP C117 051
				RLM 23	H414 MMP C114 003
				WHITE	H11 MMP C62 001

C W. Nr. 257, flown by Hptm. Joachim Müncheberg, CO of II./ JG 26, Abbeville-Drucat, France, May 1942

Future recipient of the Knight's Cross with Oak Leaves and Swords, Joachim Müncheberg was born on December 31st, 1918 in the Pomeranian town of Friedrichsdorf. He joined the army in December 1936 and two years later, the Luftwaffe. He was assigned to the III. Gruppe JG 26 in October 1939 and was given command of its 7. Staffel on August 20th, 1940. From February 1941, this unit served in the Mediterranean area. First over the island of Malta, and then over Yugoslavia, Munchenberg downed two Avia BH-33 aircraft. This was followed by a post in Northern Africa and in August 1941, his unit was reassigned to the Channel area. On September 19th, of the same year, Munchenberg was named CO of II. Gruppe JG 26. At the beginning of October 1942, he took command of JG 77, at that time operating in North Africa. Munchenberg's final flight is recorded as being on the 23rd of March, 1943. Over Tunisia he achieved his 135th kill, but Cpt. Theodore Sweetman's Spitfire from the 52nd FG exploded and shrapnel from the explosion damaged Munchenberg's Messerschmitt Bf 109G-6 (W.Nr. 16381). Severely injured, he bailed out of his aircraft, and a rescue team found him with no vital signs. The aircraft with the double chevron Gruppe Commander markings is camouflaged in the standard scheme of RLM 74/75/76. Victory markings up to May 6th, 1942 appear on the rudder. They carry the national insignia of each individual kill.

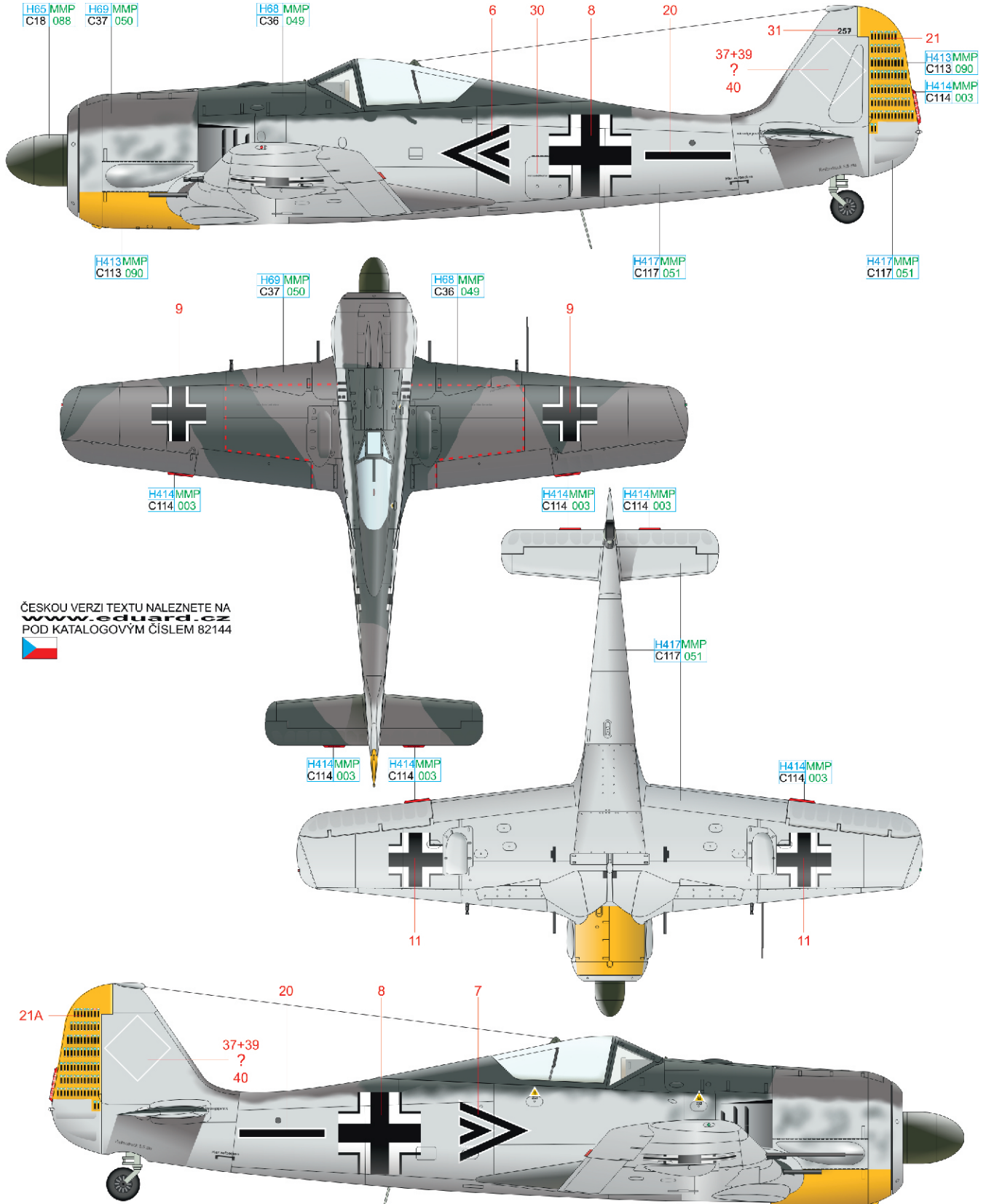

ČESKOU VERZI TEXTU NALEZNETE NA
www.eduard.cz
 POD KATALOGOVÝM ČÍSLEM 82144



RLM 70	H65 MMP C18 088	RLM 04	H413 MMP C113 090	RLM 23	H414 MMP C114 003
RLM 74	H68 MMP C36 049	RLM 75	H69 MMP C37 050	RLM 76	H417 MMP C117 051

D W. Nr. 2278, flown by Uffz. Erich Pflaum, 2./ JG 51, Ljuban, Soviet Union, September 1942

I. Gruppe JG 51 was, in the summer of 1942, chosen to be the first of the units serving on the Eastern Front to be re-equipped with the Fw 190. It moved to Königsberg, where it was assigned a mix of Fw 190A-1, A-2 and A-3s, and after conversion training returned back to the northern sections of the Eastern Front at the end of August 1942. The first Fw 190A-3 from I./JG 51 that was lost in combat was piloted by Uffz. Erich Pflaum on September 29th, 1942. The pilot, although injured, survived. The aircraft flown by Erich Pflaum was painted in a non-standard scheme consisting of two shades of dark green. Exactly what these two greens were is as yet unclear. One possibility is a combination of RLM 70 and 71. The yellow lower wingtips, the fuselage band in the same colour below the fuselage cross identified this aircraft as having served on the Eastern Front. The engine cowl carries the unit marking of JG 51 and below the windscreen is the insignia of I./JG 51. The original yellow fuselage band is still visible under the camouflage paint. The thin black tape bordering the yellow band below the fuselage cross probably served to sharpen its edge during the paint work conducted on the aircraft.

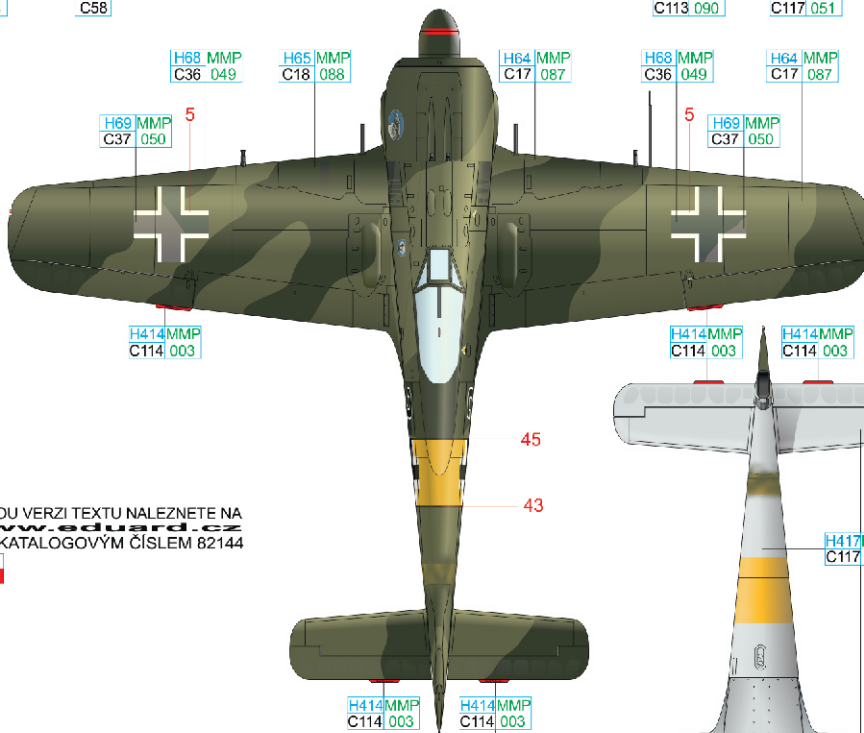
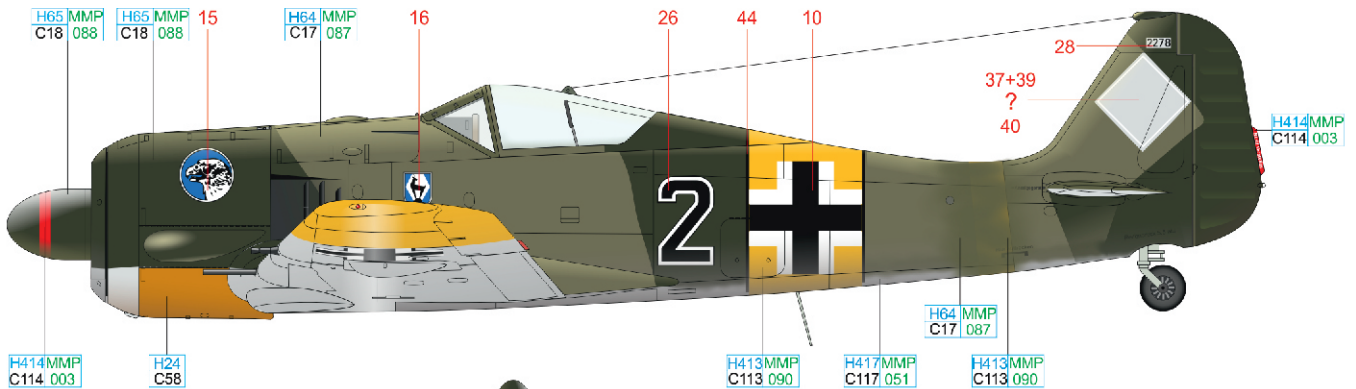

ČESKOU VERZI TEXTU NALEZNETE NA www.eduard.cz POD KATALOGOVÝM ČÍSLEM 82144

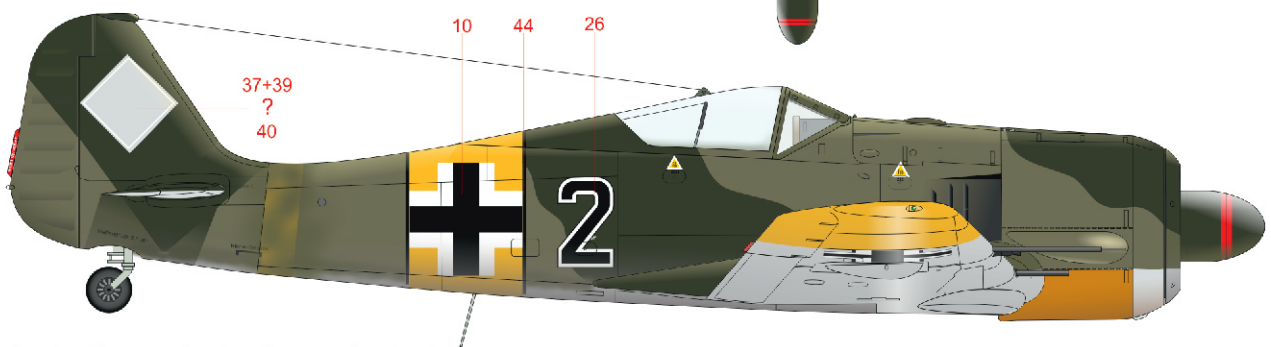
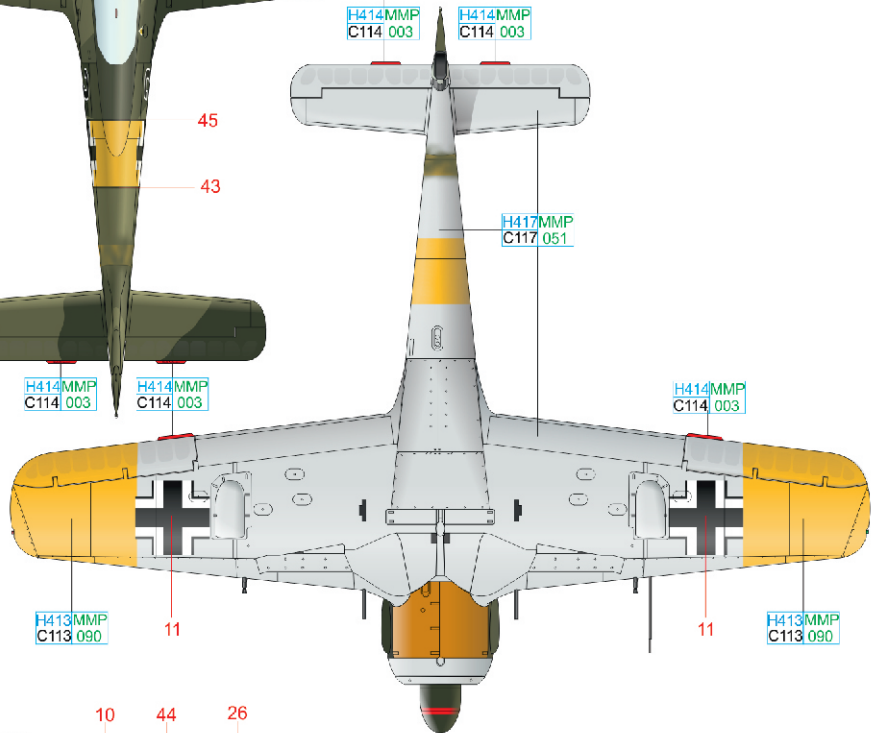

RLM 70	H65 MMP C18 088	RLM 04	H413 MMP C113 090	RLM 23	H414 MMP C114 003
RLM 74	H68 MMP C36 049	RLM 75	H69 MMP C37 050	RLM 76	H417 MMP C117 051
				BLACK	H12 MMP C33 047
				RLM 71	H64 MMP C17 087
				ORANGE YELLOW	H24 C58

E W. Nr. 5227, flown by Fw. Karl Willius, 3./JG 26, Saint-Omer, France, August 1942

Karl Willius was born on November 5th, 1919 in Mainz. After training as a fighter pilot, he was assigned to 8./JG 51 on May 17th, 1940 with which he would take part in the Battle of Britain and the early phases of the war against the Soviet Union. On July 14th, 1941, he was transferred to 3./JG 26, continuing in combat over the Channel and also over the Soviet plains. In August 1943, after returning to France, he was reassigned to 2. Staffel and on November 25th, he would take command of that unit. On August 8th, 1944, he would shoot down his last (50th) enemy aircraft, an American B-24 of the 44th BG, but subsequently was killed in combat with Thunderbolts of the 361st FG. He was posthumously awarded the Knight's Cross. The aircraft carries the flags of the nations, where Karl Willius fought, under the cockpit. The yellow under the engine cowling appears darker than the other yellow identifiers on the aircraft, but this is likely the result of a darker shade of yellow itself. The white stripe on the propeller blade was applied in chalk and served to aid in the fuselage gun synchronisation.

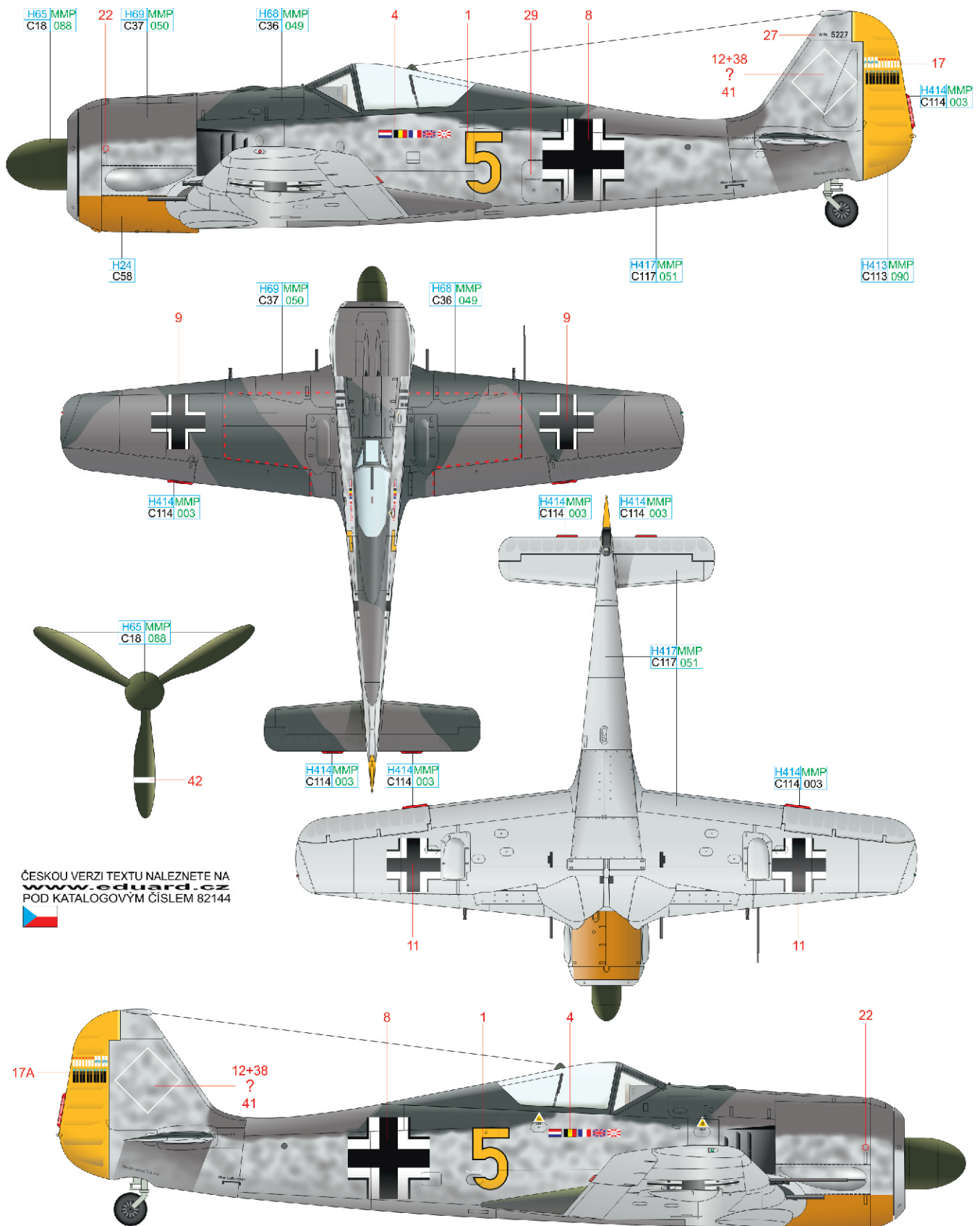

ČESKOU VERZI TEXTU NALEZNETE NA www.eduard.cz POD KATALOGOVÝM ČÍSLEM 82144



RLM 70	H65 MMP C18 088	RLM 04	H413MMP C113 090	RLM 23	H414MMP C114 003
RLM 74	H68 MMP C36 049	RLM 75	H69 MMP C37 050	RLM 76	H417MMP C117 051
				ORANGE YELLOW	H24 C58

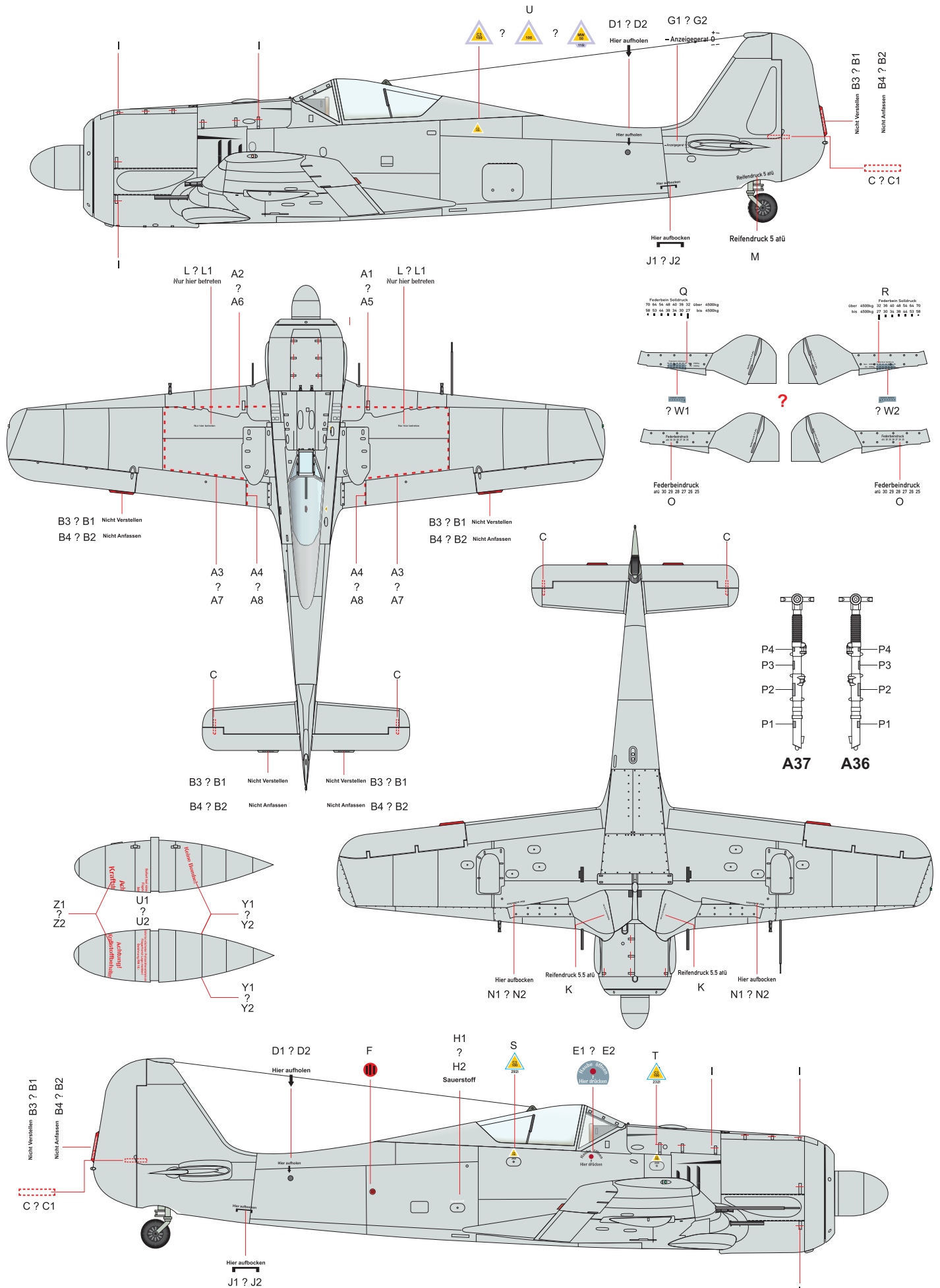

Fw 190A-3

1/48

#82144

ProfiPACK

edition

RELATED PRODUCTS:

- 48956 Fw 190A-3 (PE-Set)
- FE863 Fw 190A seatbelts STEEL (PE-set)
- 648152 Fw 190 wheels early (Brassin)
- 648356 Fw 190A wingroot gun bays (Brassin)
- 648364 Fw 190A-3 engine (Brassin)
- 648366 Fw 190A propeller (Brassin)
- 648367 Fw 190A-3/A-4 undercarriage legs BRONZE (Brassin)
- 648357 Fw 190A-3 cockpit (Brassin)
- 648371 Fw 190A control surfaces early (Brassin)
- 648373 Fw 190A Pitot tubes early (Brassin)
- 648381 Fw 190A exhaust stacks (Brassin)

eduard

