

Pro Scale

Heller

KIT NO. 91-51 T-BIRD TRIO NO.1

Canadair T-33AN Silver Star Mk.3, s/n 21500 (along with s/n 21616) was flown by the "Golden Hawks" Aerobatic Team as a "hack" or communications aircraft. During the airshow season tour, the two aircraft transported the Team Commanding Officer, Engineering Officer, Public Relations Officer, and Team Commentator. Closely resembling the team's Sabres, the aircraft was resplendent in the gold paint scheme with the distinctive "Golden Hawks" motif on the fuselage sides and on the outer faces of the tip tanks.

Lockheed T-33 AN Shooting Star s/n 53-5547 flew as a support aircraft with the USAF "Thunderbirds" Air Demonstration Squadron in 1957. The aircraft was finished in a scheme similar to the F-100C Super Sabres flown by the team. While the basic USAF finish scheme and markings were retained, the distinctive "Thunderbird" motif, which changed and evolved over the years of the team's existence, clearly identified the aircraft as a member of the team.

Canadair T-33AN Silver Star Mk.3 s/n 21592 (along with 21490) was flown as a "hack" or communications aircraft with the "Golden Centennaires" Aerobatic Team which toured Canada in 1967, Canada's Centennial Year. The aircraft was finished in a scheme closely resembling the team's Canadair Tutors, a dazzling combination of gold and dark blue with the distinctive Centennial Maple Leaf design and red and white "Golden Centennaires" flash.

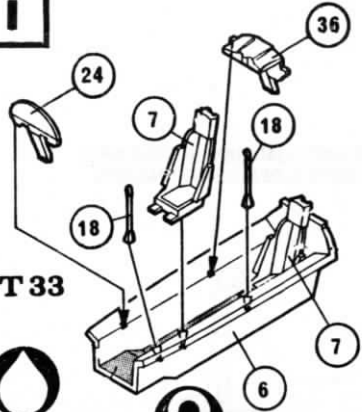
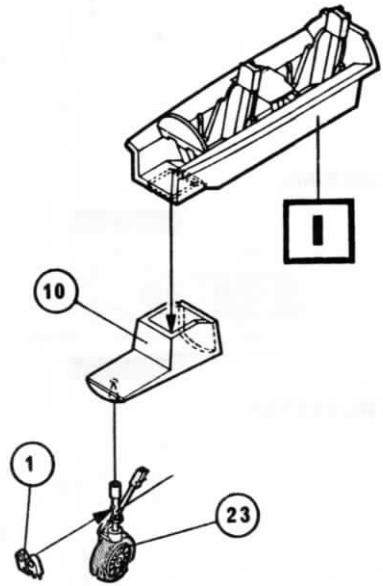
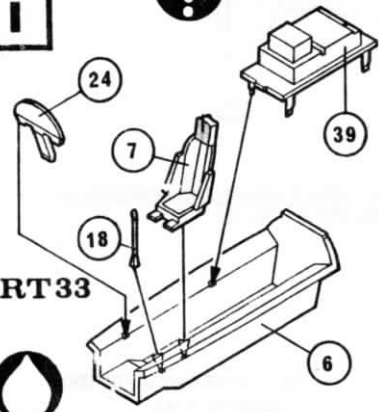
1**2****1**

3

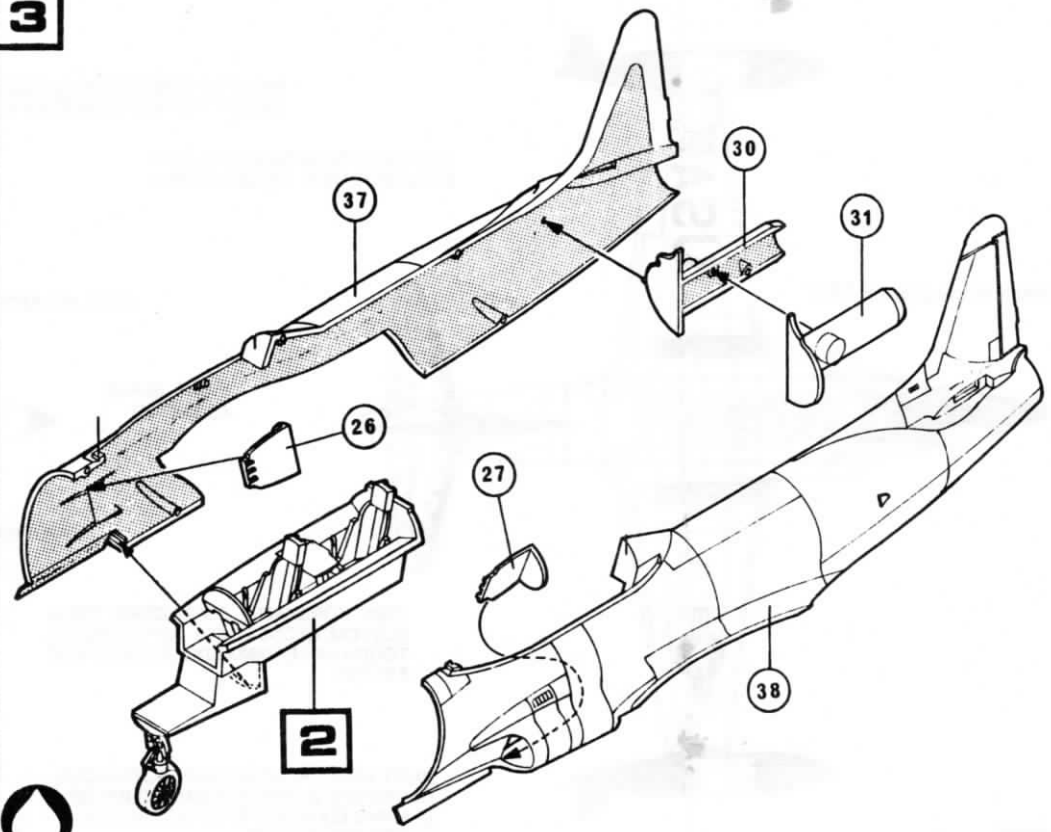

4

T33

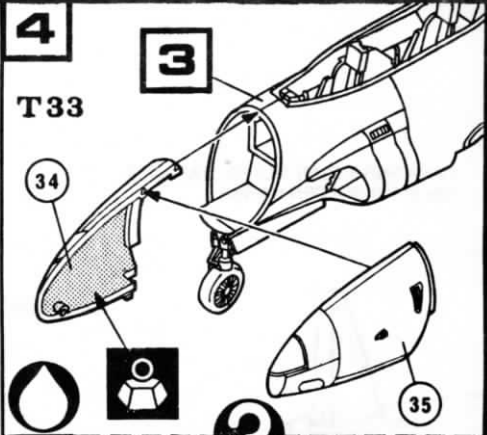

4

RT33

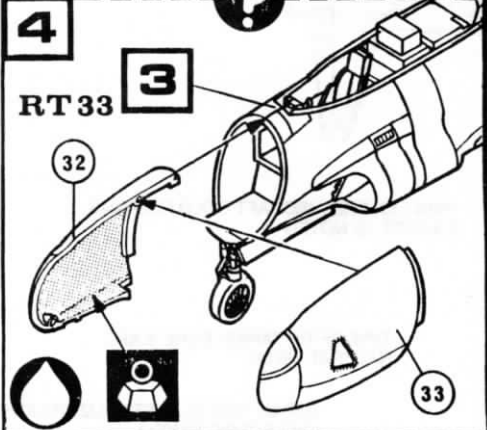

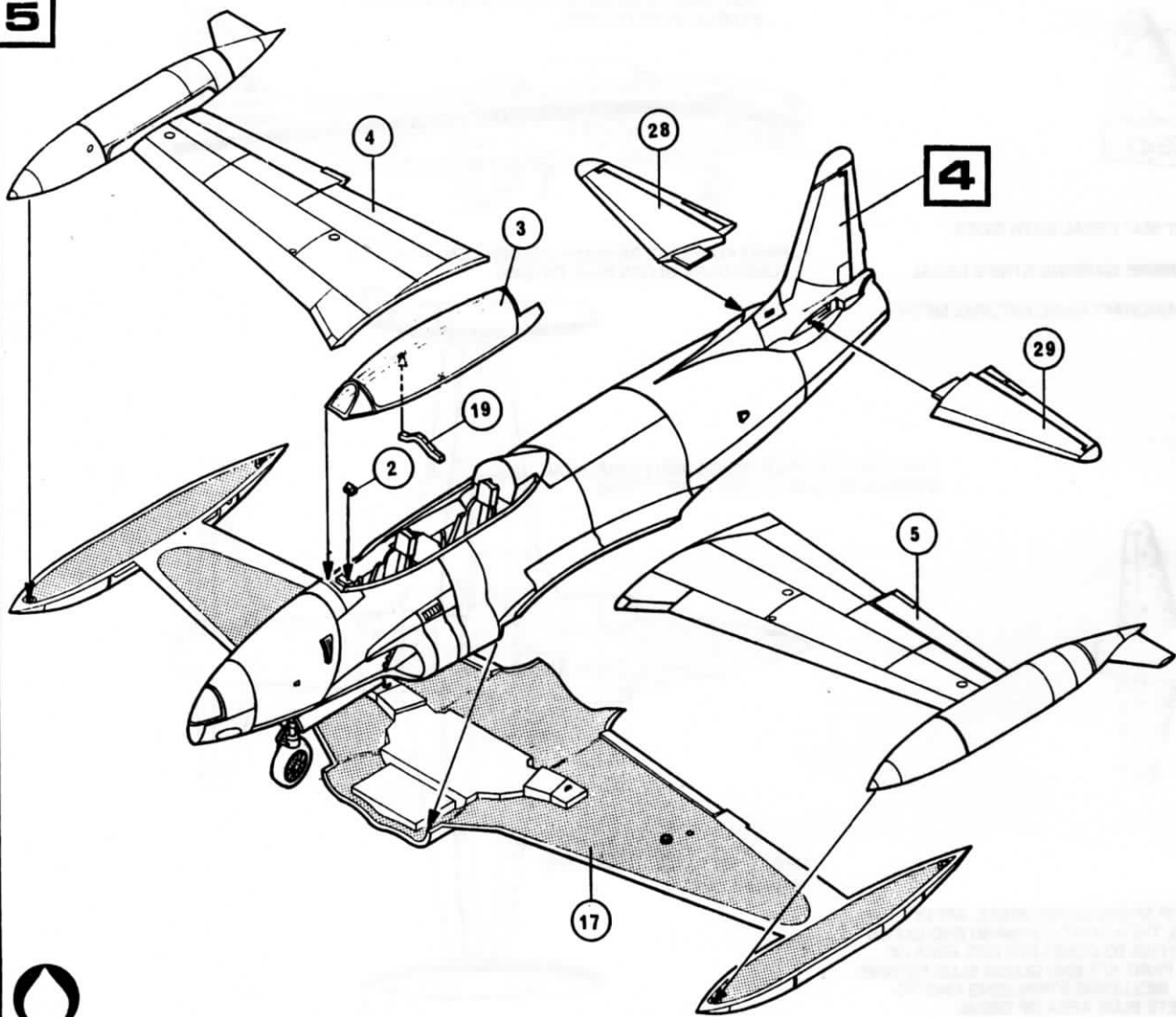

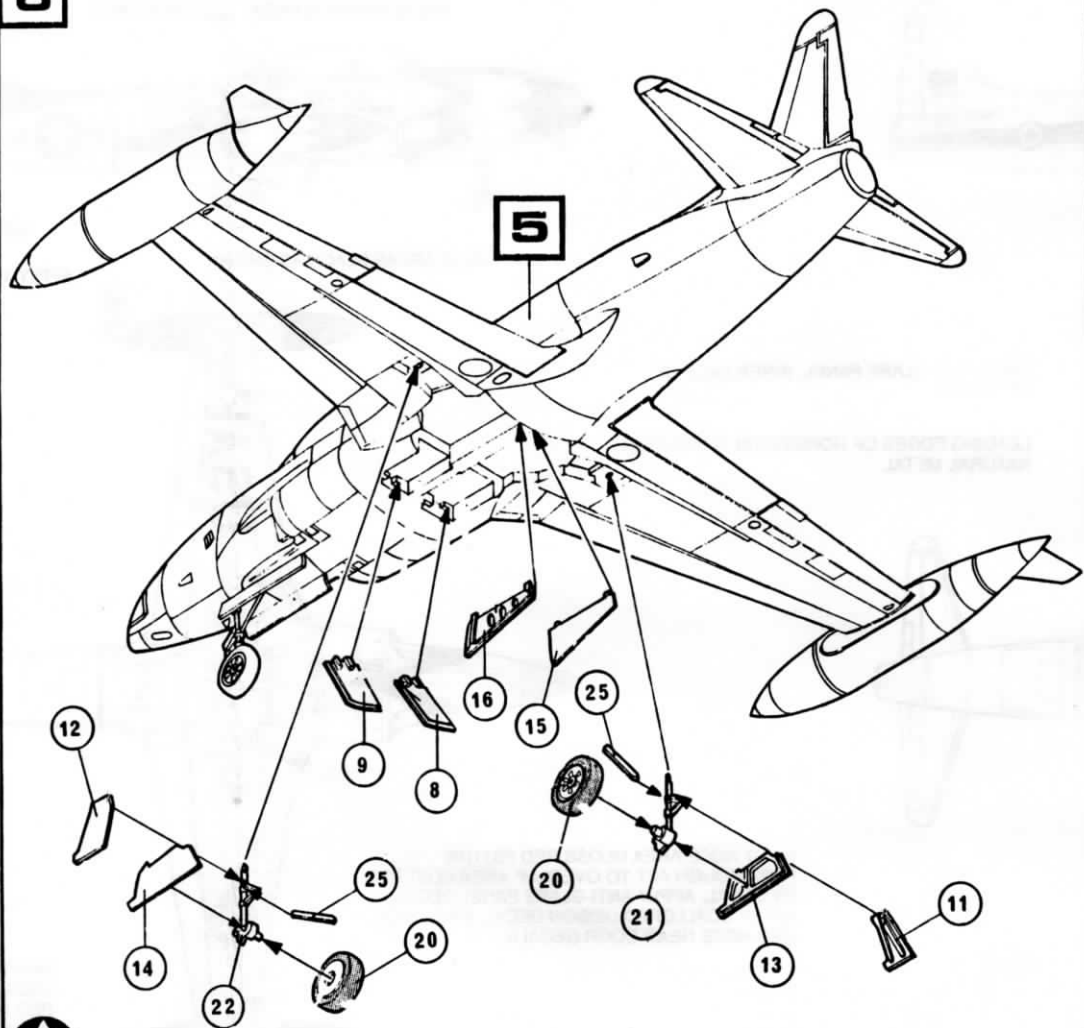

CANADAIR T-33AN SILVER STAR MK.3
S/N 21500 GOLDEN HAWKS

APPLY ANTI-GLARE PANEL DECAL

APPLY WING WALK DECAL

APPLY WING WALK DECAL BOTH SIDES

WING LEADING EDGES NATURAL METAL

PAINT ENTIRE AIRCRAFT GOLD FS176043
EXCEPT AS NOTED

TIPS OF TIP TANKS, FORE & AFT
NATURAL METAL

TOP OF VERTICAL STABILIZER LIGHT GREY
(DIELECTRIC PANEL)

PAINT BLACK AS SHOWN

LEADING EDGE OF VERTICAL STABILIZER
NATURAL METAL



TIP OF NOSE NATURAL METAL

PAINT

PAINT ANTI-GLARE PANEL, INNER FACE OF
TIP TANKS

LEADING EDGES OF HORIZONTAL STABILIZER
NATURAL METAL

PAINT NOSE AREA GLOSS RED
FAR ENOUGH AFT TO OVERLAP
BY DECAL. APPLY ANTI-GLARE P
APPLY SCALLOPED DESIGN DEC
AND NOSE GEAR DOOR DECALS

TAR MK.3

PAINT TIP TANKS DARK GLOSS
EXCEPT FOR ANTI-GLARE PA

LOCKHEED T-33A SHOOTING STAR
S/N 53-5547 USAF THUNDERBIRDS

APPLY WING WALK DECALS, EACH SIDE.

NOTE: NO AN

PAINT BLACK
AS SHOWN

APPLY

OLD FS176043

PAINT HORIZONTAL STABILIZERS, TOP &
BOTTOM, GLOSS WHITE. APPLY DECALS,
TOUCH UP LEADING EDGES GLOSS RED
FS11105

FORE & AFT

PAINT VERTICAL STABILIZER, BOTH SIDES,
GLOSS WHITE. APPLY DECAL, TOUCH UP
LEADING EDGE AND PAINT DORSAL FIN
GLOSS RED, FS11105

TICAL STABILIZER LIGHT GREY
(PANEL)

APPLY THUNDERBIRDS DECAL, LEFT SIDE,
U/S/ AIRFORCE ON RIGHT SIDE. APPLY
THUNDERBIRDS DECAL LEFT SIDE ONLY.



APPLY 5547 DECAL BOTH SIDES

PAINT THESE AREAS BLACK AS SHOWN

APPLY TURBINE WARNING STRIPE DECAL

AIRCRAFT BASIC NATURAL METAL

, INNER FACE OF

HORIZONTAL STABILIZER

PAINT UNDERSIDE
STABILIZERS DARK

PAINT NOSE AREA GLOSS RED FS11105
FAR ENOUGH AFT TO OVERLAP AREA COVERED
BY DECAL. APPLY ANTI-GLARE PANEL DECAL.
APPLY SCALLOPED DESIGN DECAL, EACH SIDE,
AND NOSE GEAR DOOR DECALS.

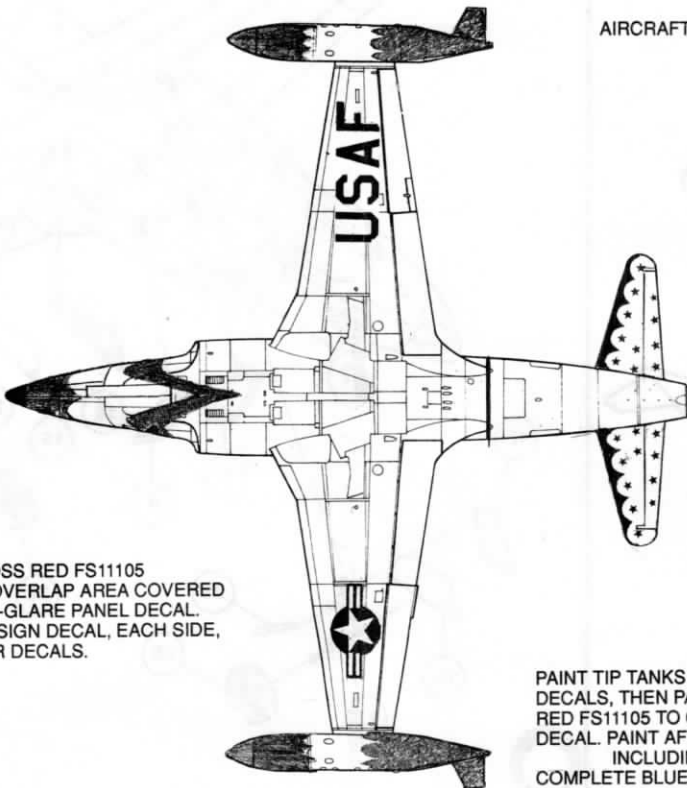

PAINT TIP TANKS GLOSS WHITE. APPLY
DECALS, THEN PAINT FORWARD END GLOSS
RED FS11105 TO COMPLETE RED AREA OF
DECAL. PAINT AFT END GLOSS BLUE FS15080
INCLUDING STABILIZING FINNS TO
COMPLETE BLUE AREA OF DECAL.

TIP
NA

PAINT TIP TANKS DARK GLOSS BLUE FS15080 EXCEPT FOR ANTI-GLARE PANELS, FLAT BLACK.

T-33A SHOOTING STAR
USAF THUNDERBIRDS

CANADAIR T-33AN SILVER STAR MK.3
S/N 21592 GOLDEN CENTENNAIRES

NOTE: NO ANTI-GLARE PANEL

PAINT BLACK AS SHOWN

APPLY WING WALK DECALS

HORIZONTAL STABILIZERS, TOP & BOTTOM, GLOSS WHITE. APPLY DECALS, TOUCH UP LEADING EDGES GLOSS RED FS15080

PAINT TOP OF WINGS AND HORIZONTAL STABILIZERS GOLD FS17043

VERTICAL STABILIZER, BOTH SIDES, GLOSS WHITE. APPLY DECAL, TOUCH UP LEADING EDGE AND PAINT DORSAL FIN GLOSS WHITE, FS11105

PAINT FUSELAGE ABOVE GOLDEN CENTENNAIRES FLASH GOLD, FS17043

PAINT VERTICAL STABILIZER GOLD FS17043

PAINT BACKGROUND TO THE CENTENNIAL LEAF SYMBOL GOLD FS17043

PAINT VERTICAL STABILIZER GLOSS WHITE

APPLY WING WALK DECALS

PAINT TIP TANKS DARK GLOSS BLUE FS15080 EXCEPT FOR ANTI-GLARE PANELS, FLAT BLACK.



PAINT FUSELAGE BENEATH GOLDEN CENTENNAIRES FLASH DARK GLOSS BLUE FS15080

PAINT UNDERSIDE OF WINGS AND HORIZONTAL STABILIZERS DARK GLOSS BLUE FS15080

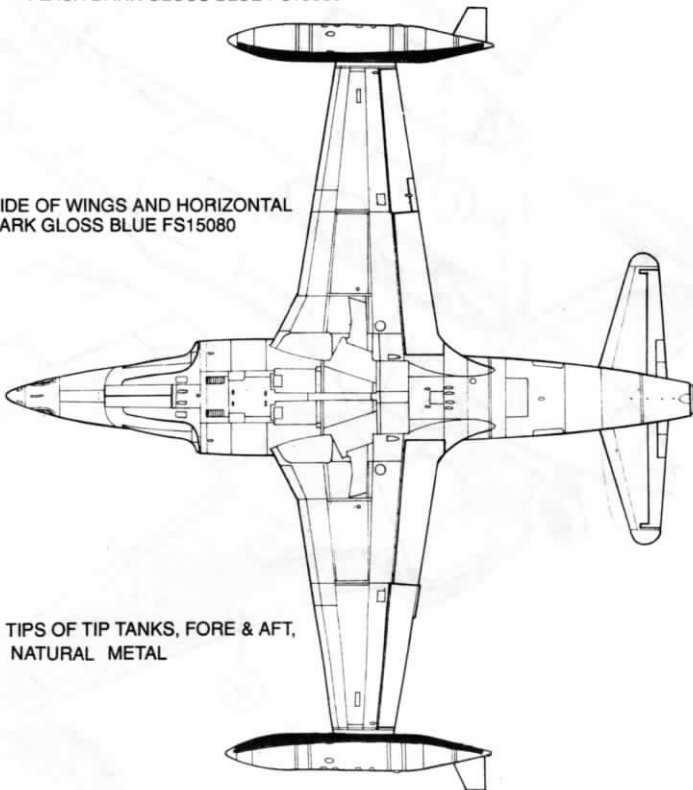

TIPS OF TIP TANKS, FORE & AFT, NATURAL METAL

PAINT FORWARD END GLOSS WHITE. APPLY COMPLETE RED AREA OF LEADING EDGE GLOSS BLUE FS15080. APPLY STABILIZING FIN TO RED AREA OF DECAL.

Announcing!

In Canadian Service No. 1 Modeling Canadian Military Aircraft

(in 1:72 scale)

by A. L. Stachiw

- A comprehensive cataloging of all Canadian military aircraft, including powerplants, dates of service, applicable kits and accessories, and commentary.
- 80 pages containing 20 photographs, 73 line drawing illustrations, fully indexed and referenced, covering some 458 types & variants
- Sub-divided into a master list & 6 sub-listings

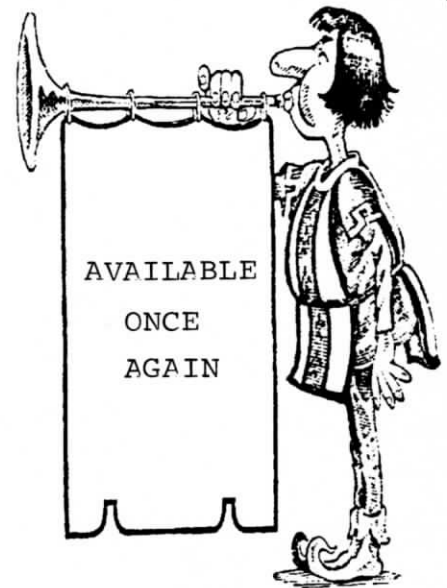

Available exclusively from Canadian Aircraft Publications.

please write for information on this and future publications to:

Canadian Aircraft Publications
471 Hazeldean Road, Unit 14
Kanata, Ontario Canada K2L 4B8
Telephone: 1-613-836-6040
Fax: 1-613-831-7397

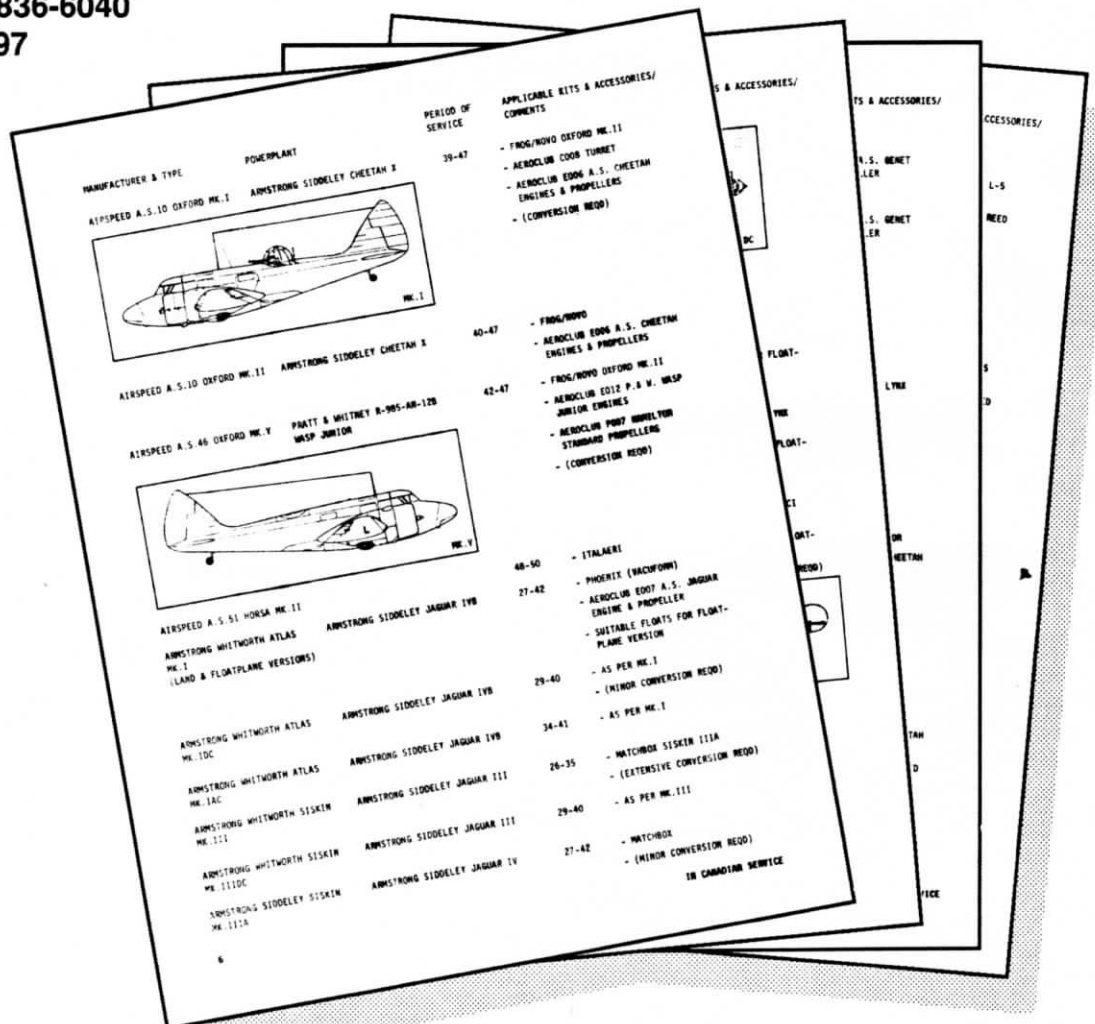

PRICE
\$14.95

PLUS

GST - PST
SHIPPING

GOLDEN HAWKS



RCAF

GOLDEN HAWKS



RCAF



U.S. AIR FORCE



5547



5547



21592 T33



T33 21592

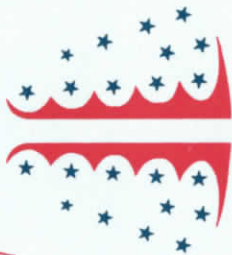
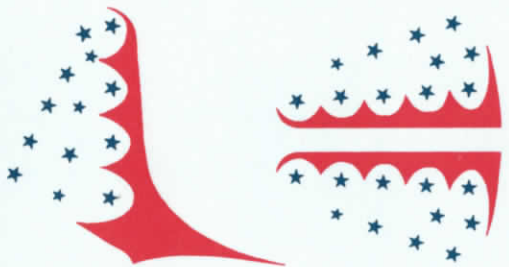

"thunderbirds"

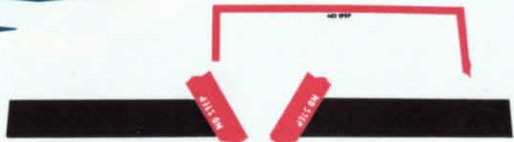
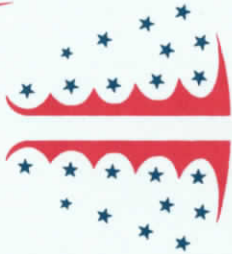
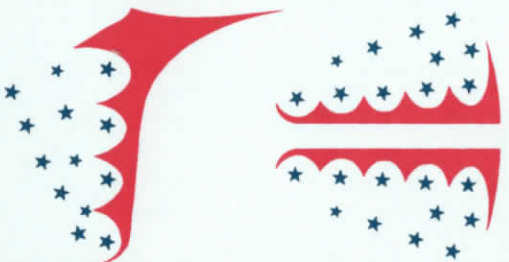

GOLDEN CENTENNAIRES



GOLDEN CENTENNAIRES

