

1/35 SCALE
5075
RIFM

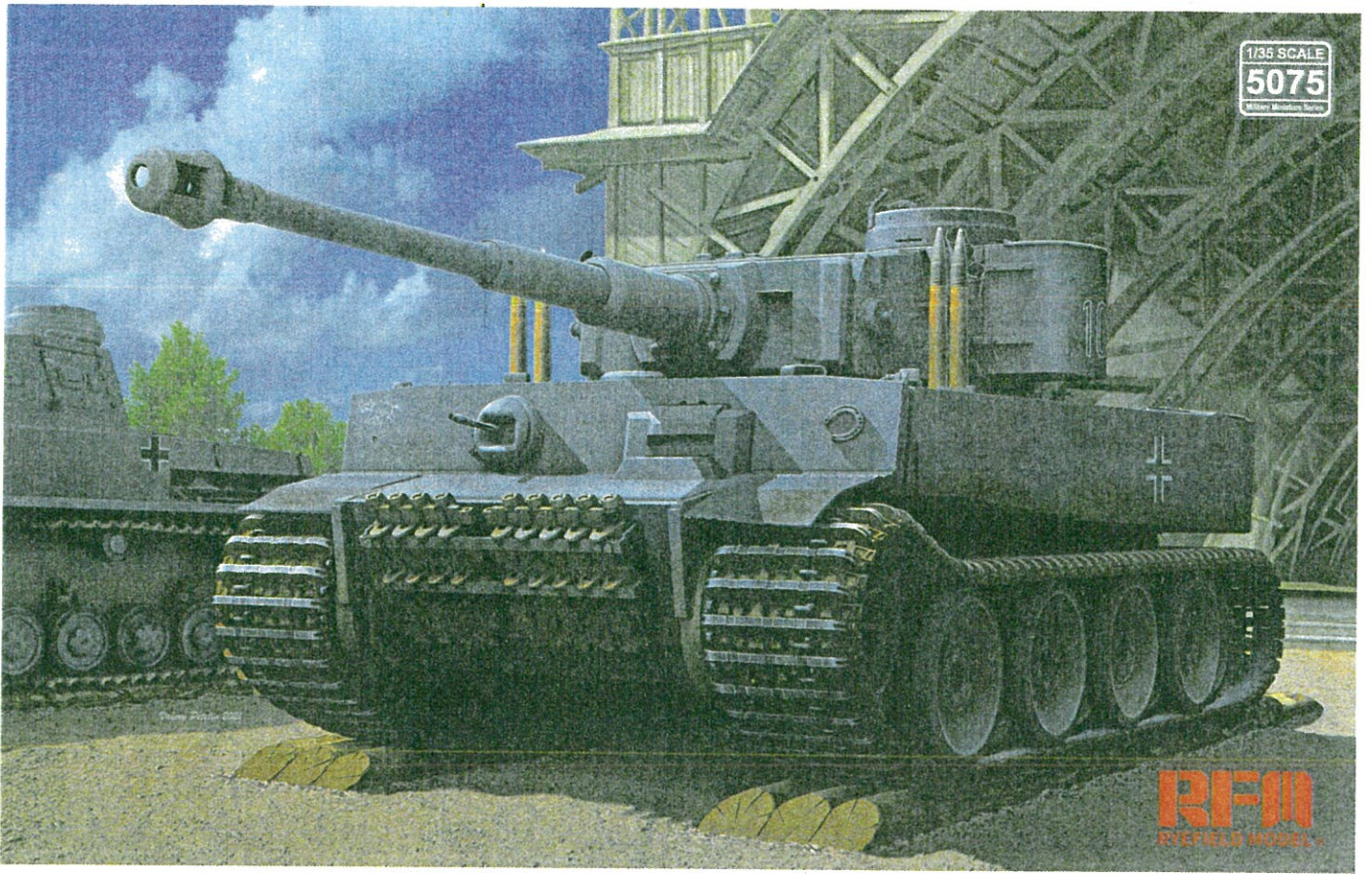

TIGER I

INITIAL PRODUCTION EARLY 1943

ASSEMBLY ICONS



OPTIONAL
选择



CEMENT
膠水



DO NOT CEMENT
不使用膠水



INSTANT CEMENT
瞬間接著劑



BEND
彎折



MAKE 2
製作2組



OPEN HOLE
鑽孔



REMOVE
切除



BE CAREFUL
注意



APPLY DECAL
貼上水貼紙

CAUTION!

Read carefully and fully understand the instructions before commencing assembly. Supervising adult should also read the instructions if a child assembles the model. When you used glue or paint, do not use near a naked flame, and use in a well-ventilated room. When assembling this kit, tools including knives are used. Extra care should be taken to avoid personal injury. Read and follow the instructions supplied with paints and/ or cement. Use plastic cement and paints only. Keep out of reach of small children. Children must not be allowed to suck any part, or pull vinyl bag over the head.

在裝配前仔細閱讀說明並完全理解。小孩裝配時需成人看護且需仔細閱讀說明。使用膠水和油漆時，應遠離火源並打開窗戶保持空氣流通。製作時請格外注意工具刀和零件的鋒利尖銳部分，避免對身體造成傷害。在使用膠水和油漆前仔細閱讀注意事項，按照說明正確使用膠水和油漆。請將本品放在兒童接觸不到的地方，套件中的塑膠包裝袋會對兒童造成窒息的危險。

PARTS 部品图

A x 1

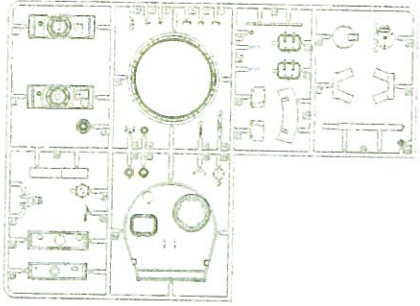

B x 1

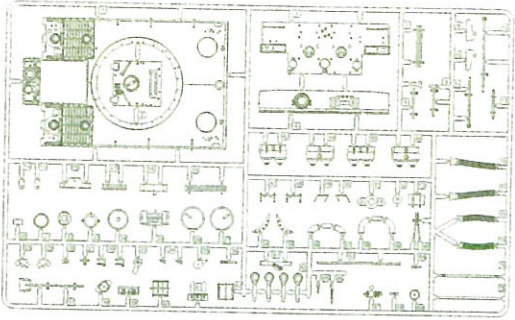

PB x 1

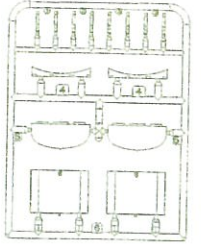

G x 1

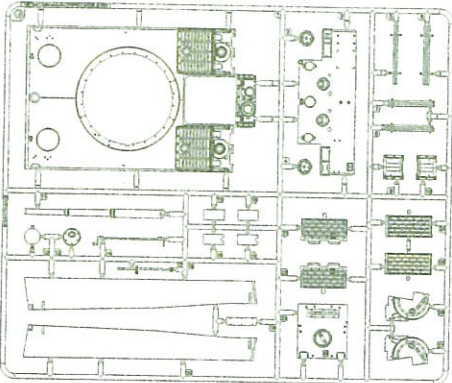

J x 1

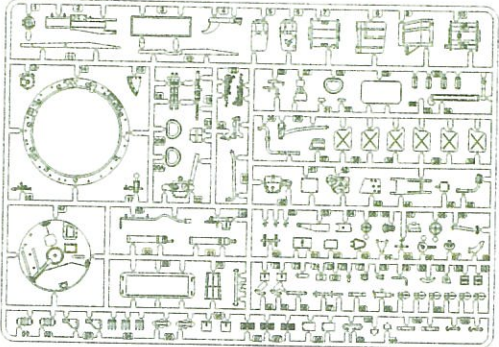

PC x 1

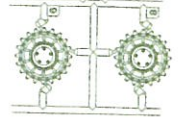

L x 18



D x 2

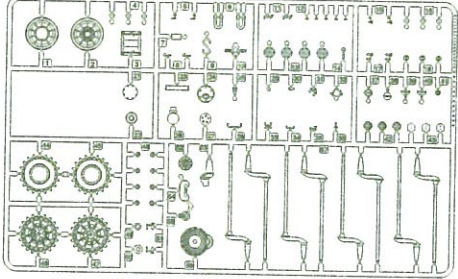

W x 1

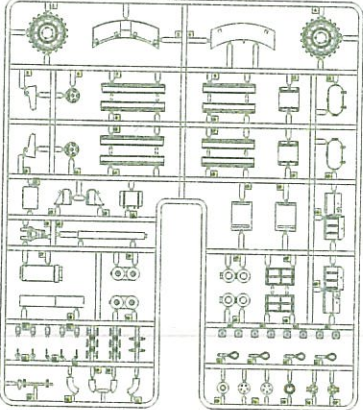

Lower hull x 1

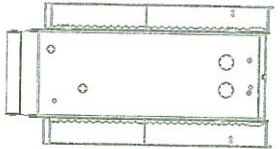

V x 4

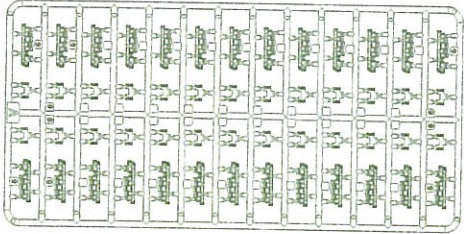

T x 1

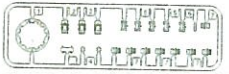

O x 1

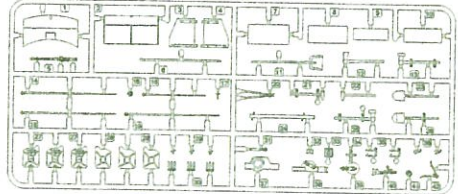

S x 1

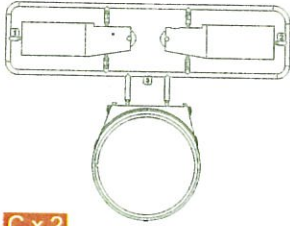

Q x 1

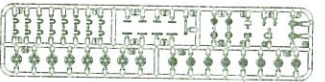

S x 1



PA x 1

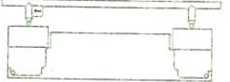

Cable 450mm



Cable 450mm



C x 2

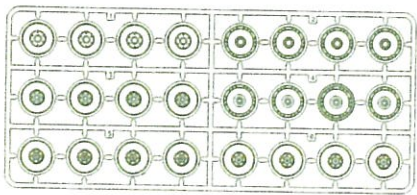

Cupola



Y x 1

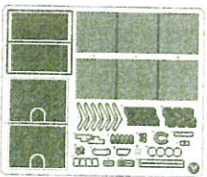

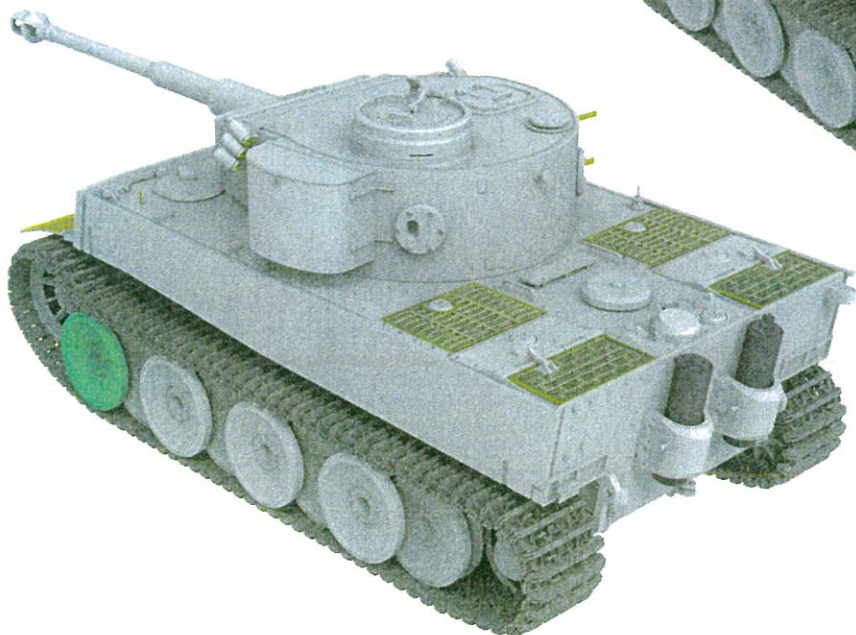
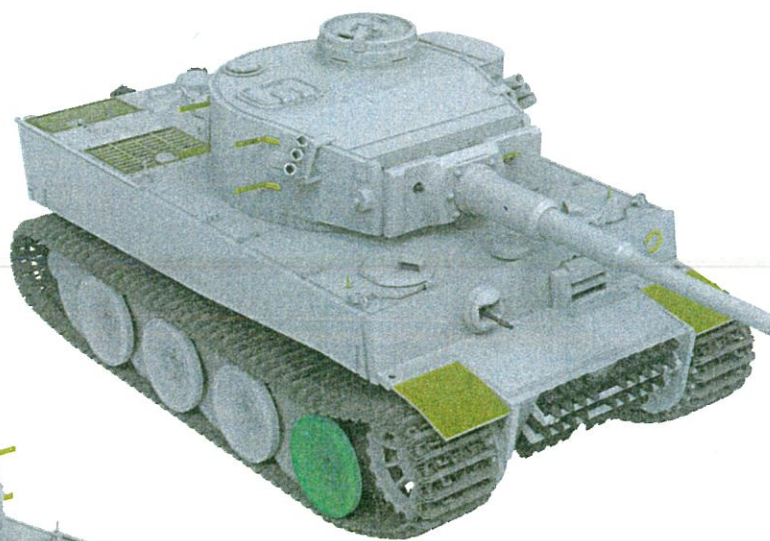
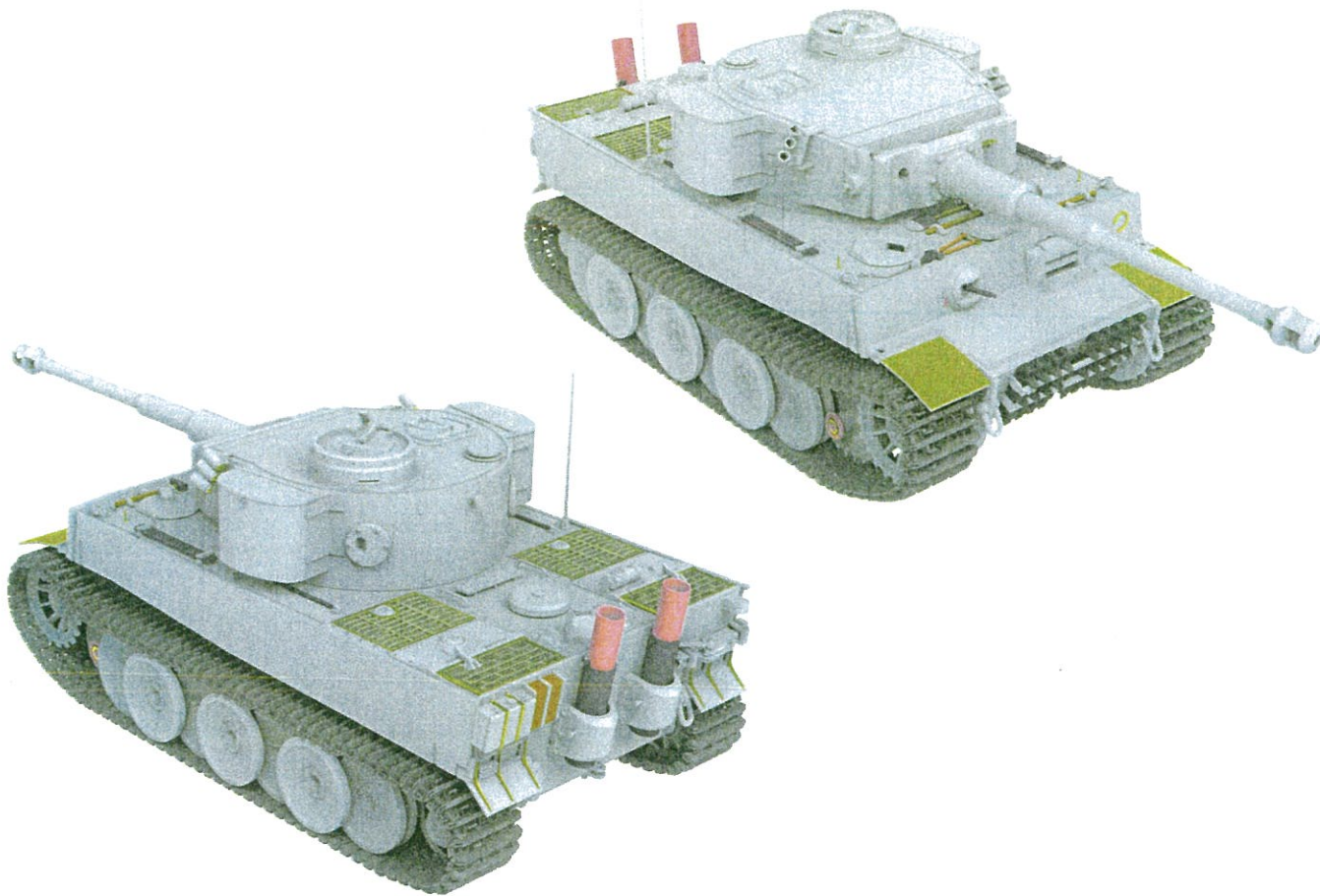

1

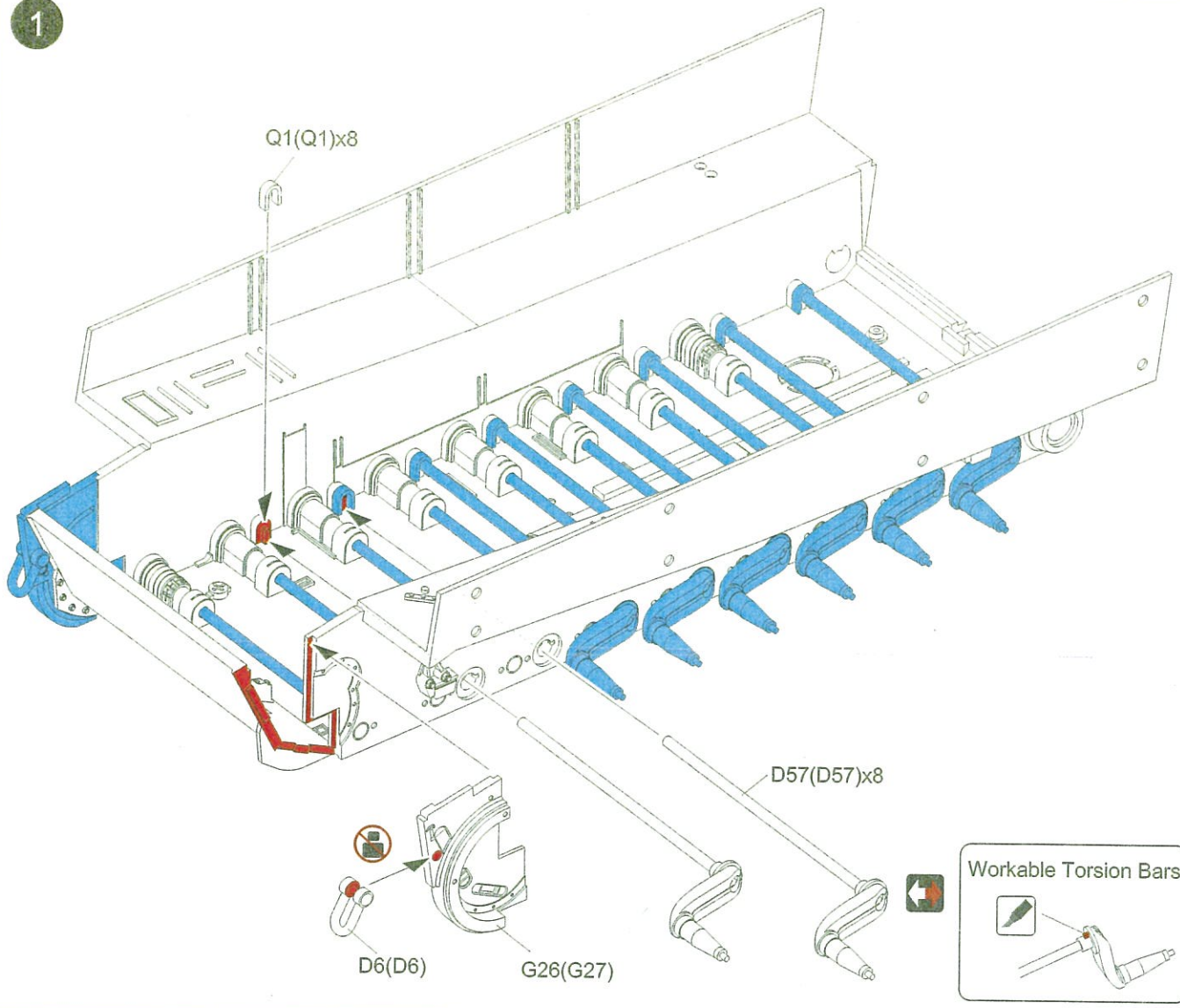

2

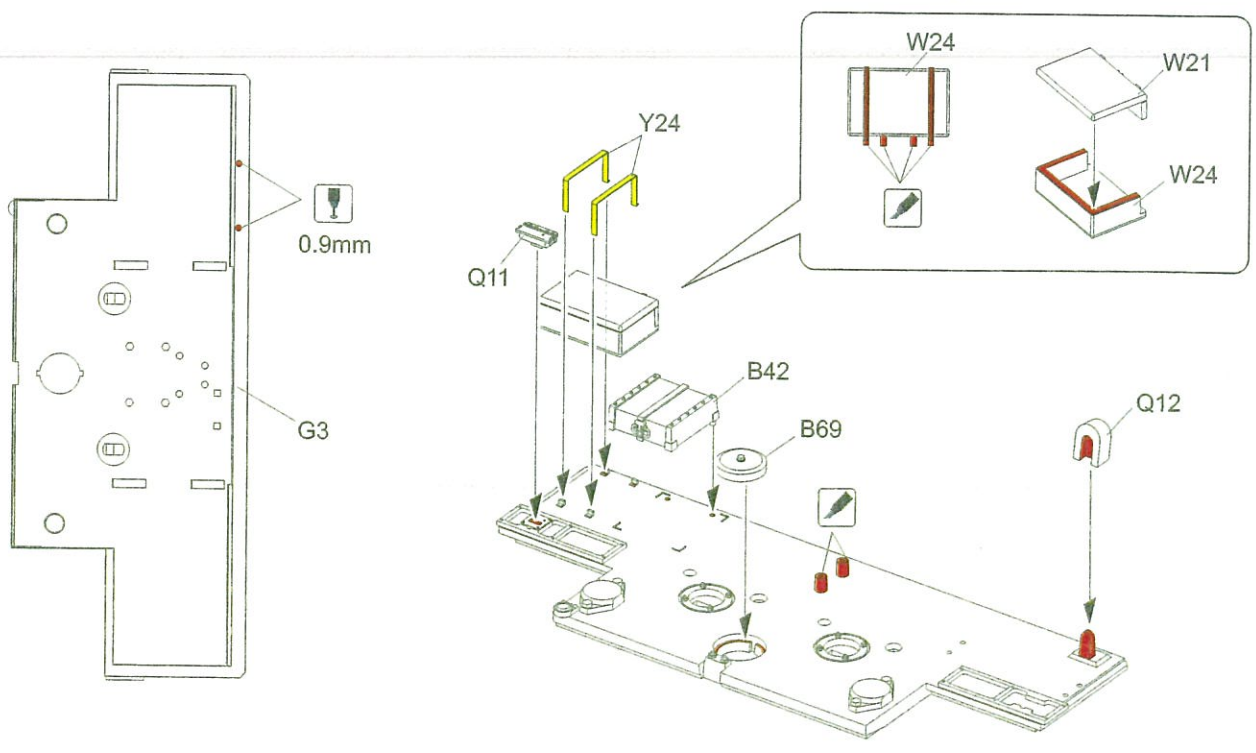

3

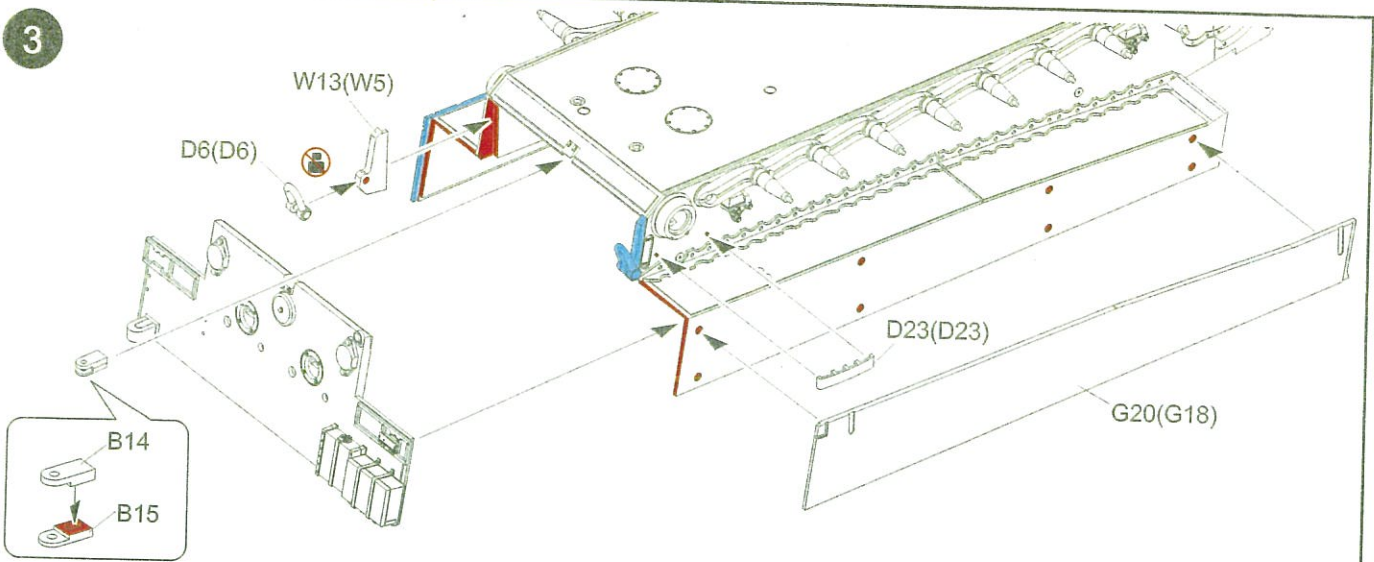

4

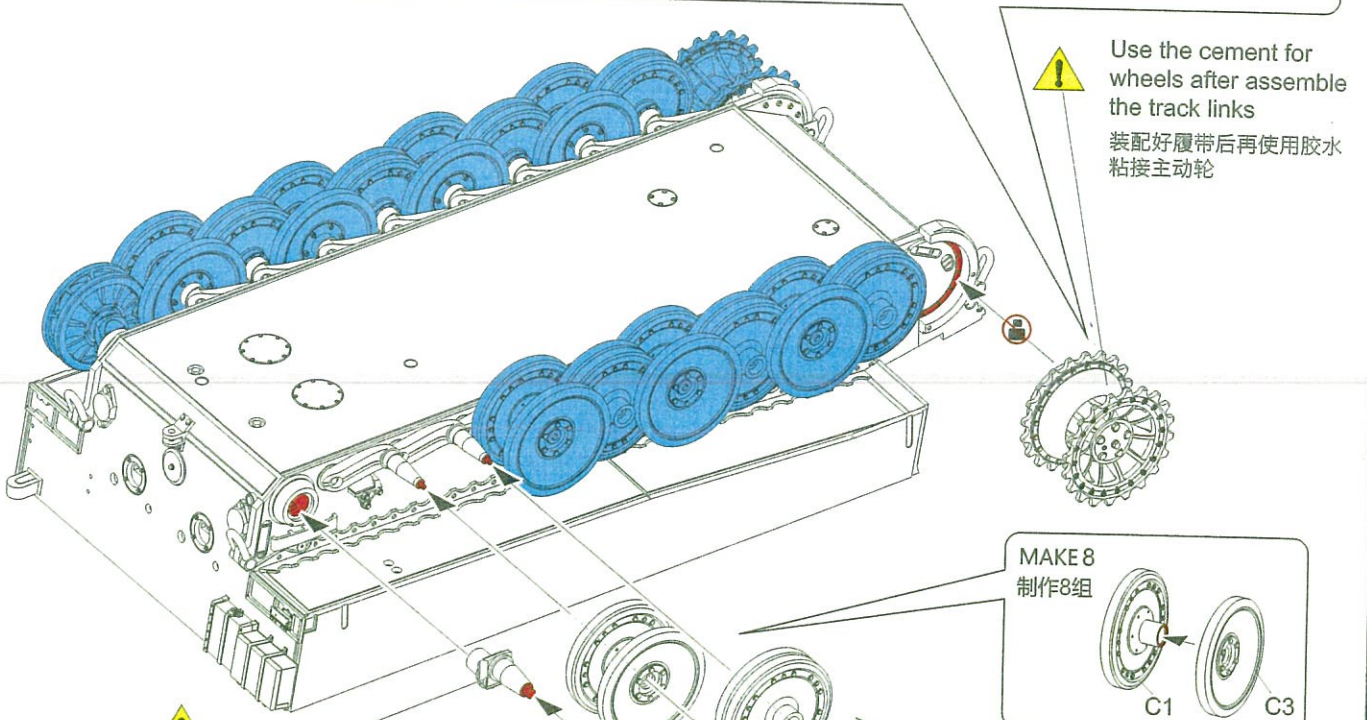
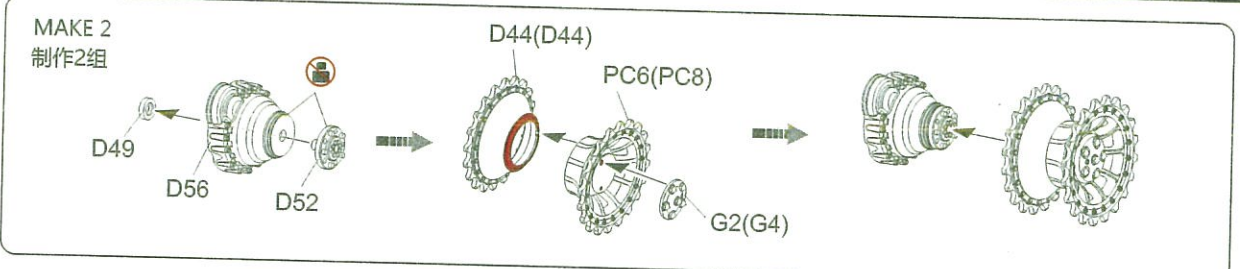

⚠ D53(D53)
Use the cement for D53 after assemble the track links
装配好履带后再使用胶水粘接 D53

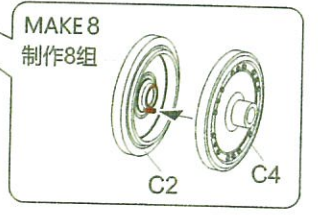
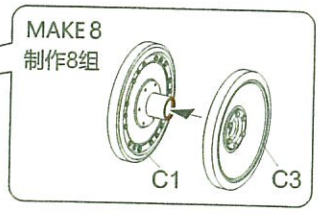
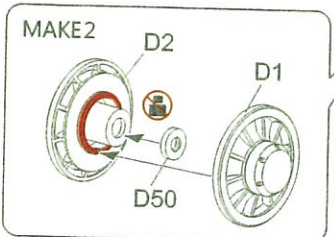

D48(D48)x8

5

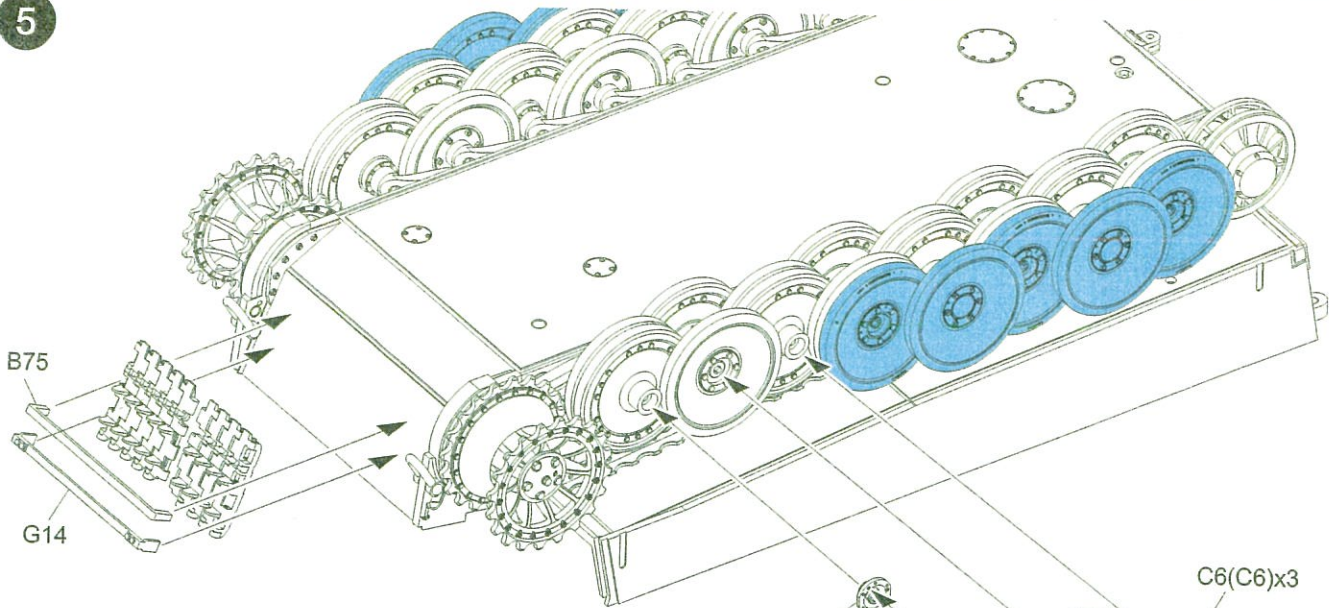

Please see page 8 for assembly steps
履带的装配请参见第8页

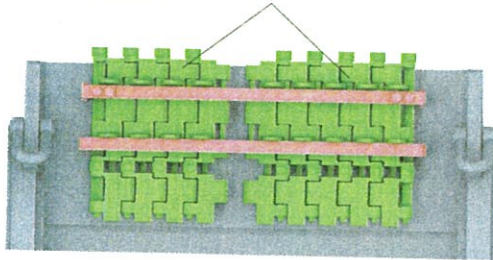

6

MAKE2
制作2组

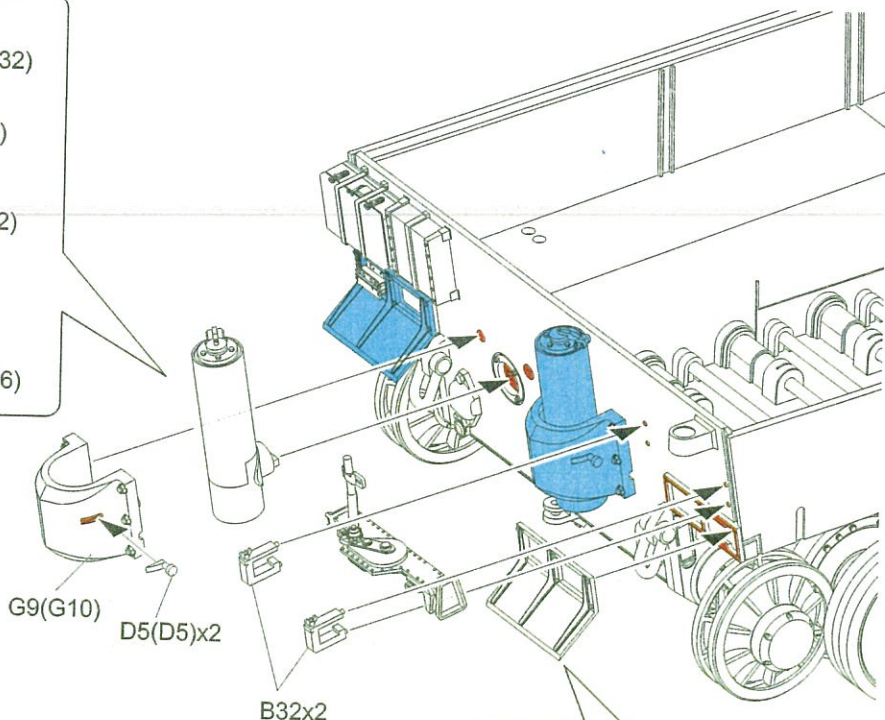
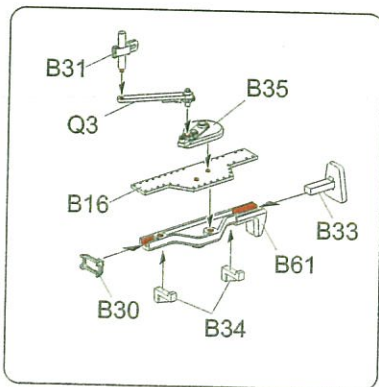
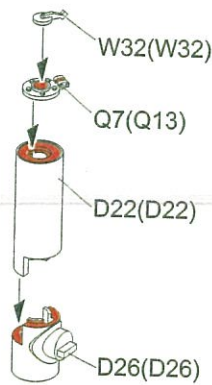

MAKE2
制作2组

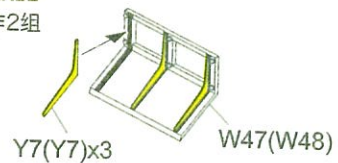

A1

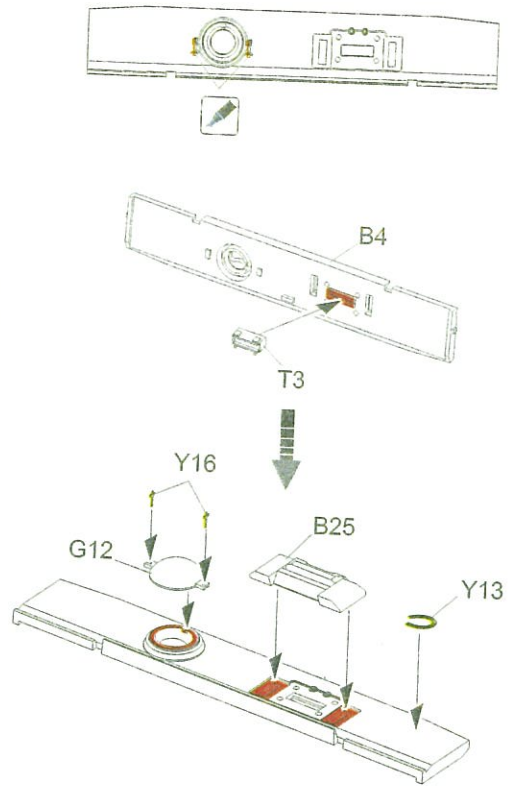
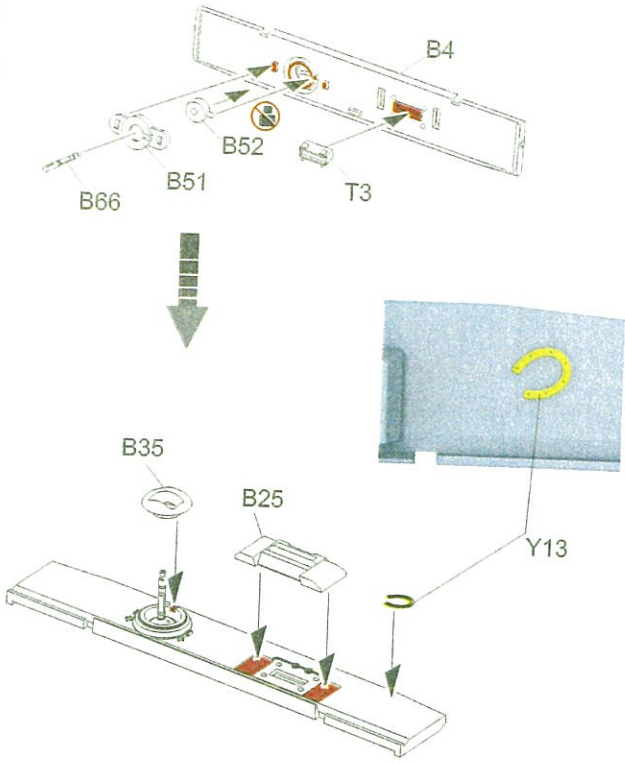

7

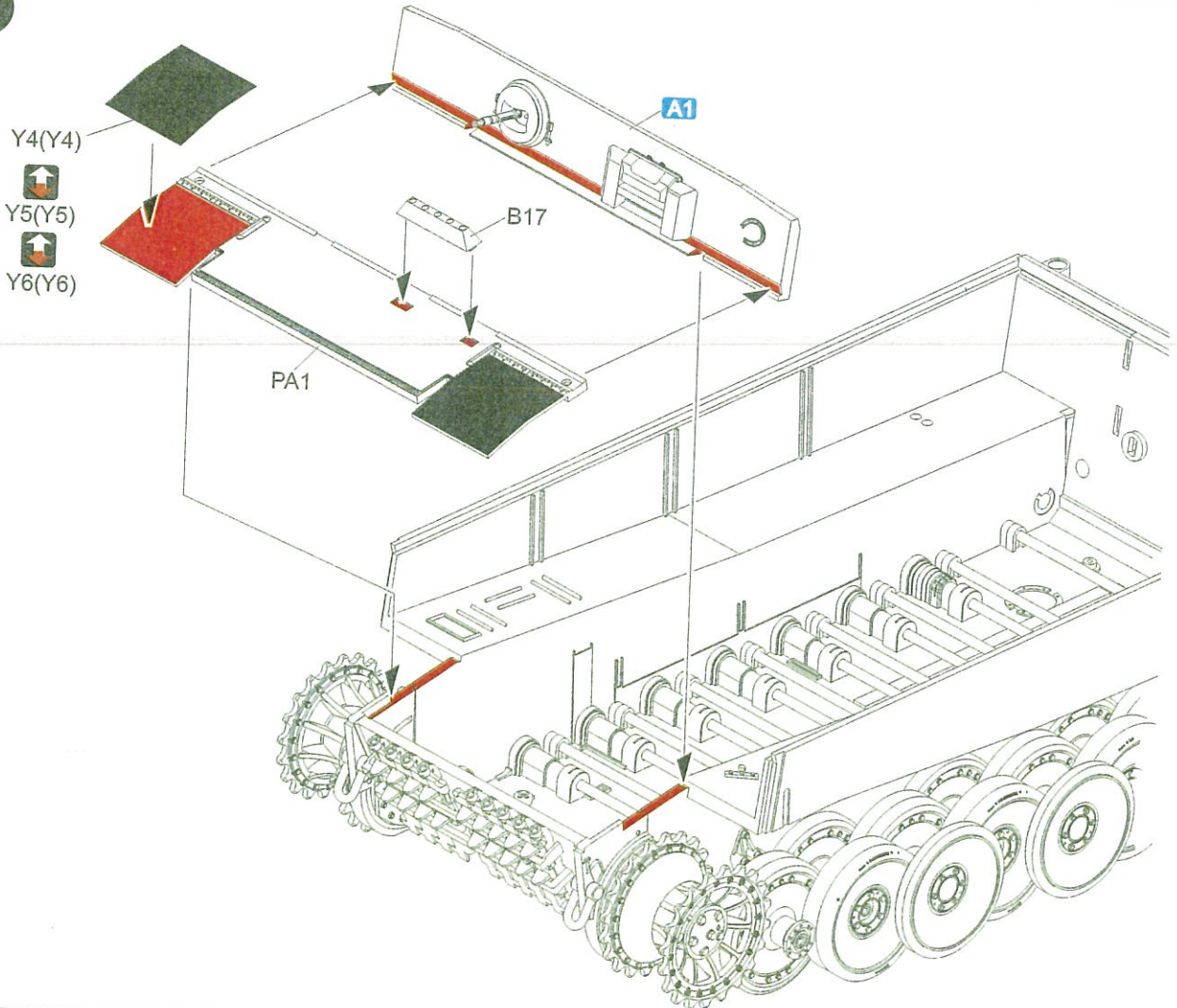

8

MAKE2
制作2组
G16(G16)
G15(G15)

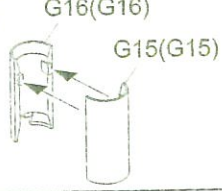

Track Links:96pcs
for each side.
每侧96节
L2(V6)
L1(V5)

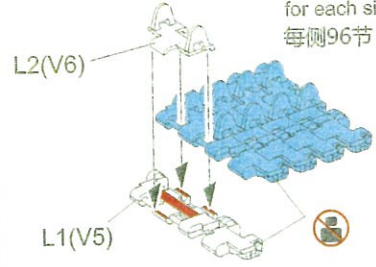

Parts V for this side
零件V用于此侧

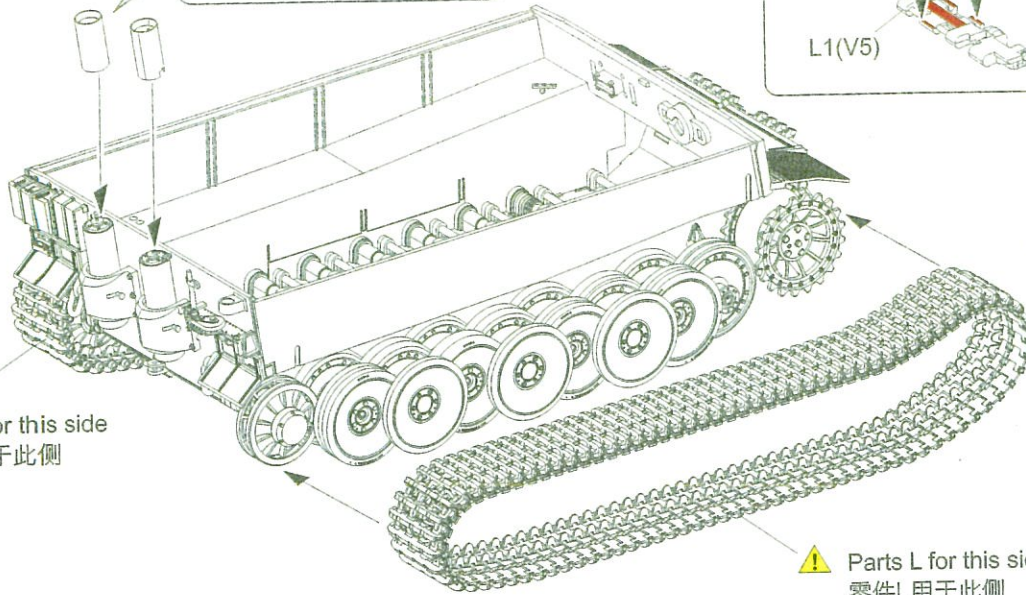

⚠ Parts L for this side
零件L用于此侧

Style A
样式A

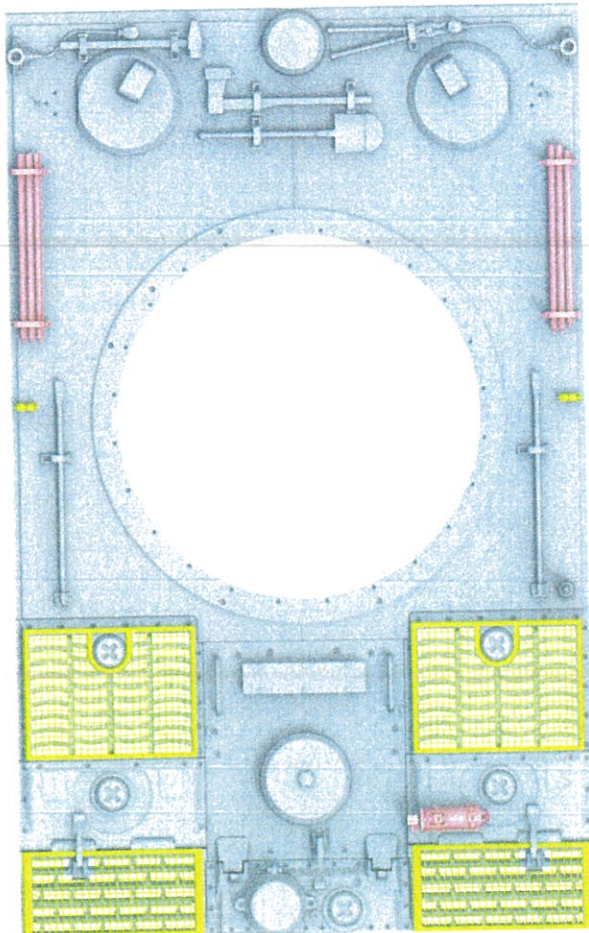

Style B
样式B

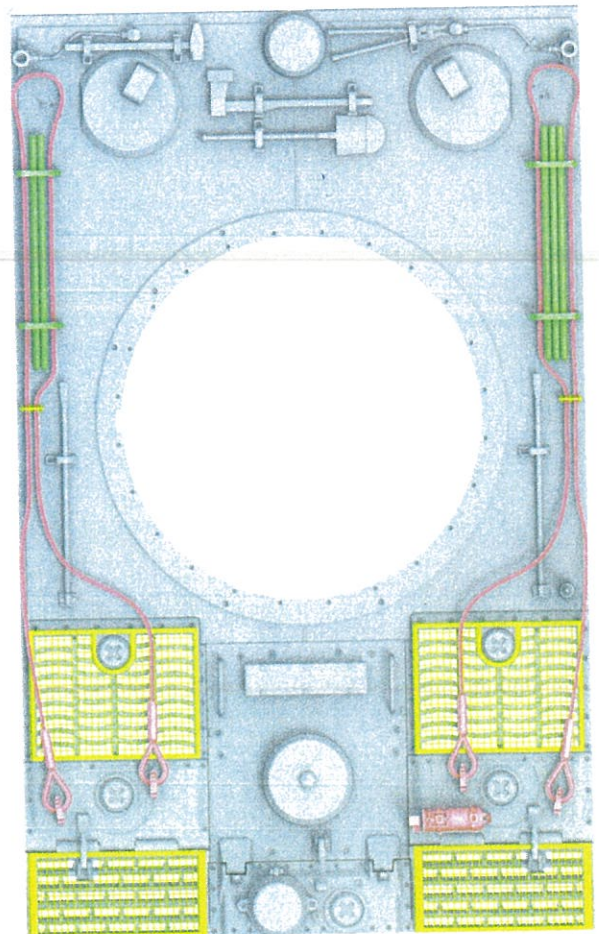

9

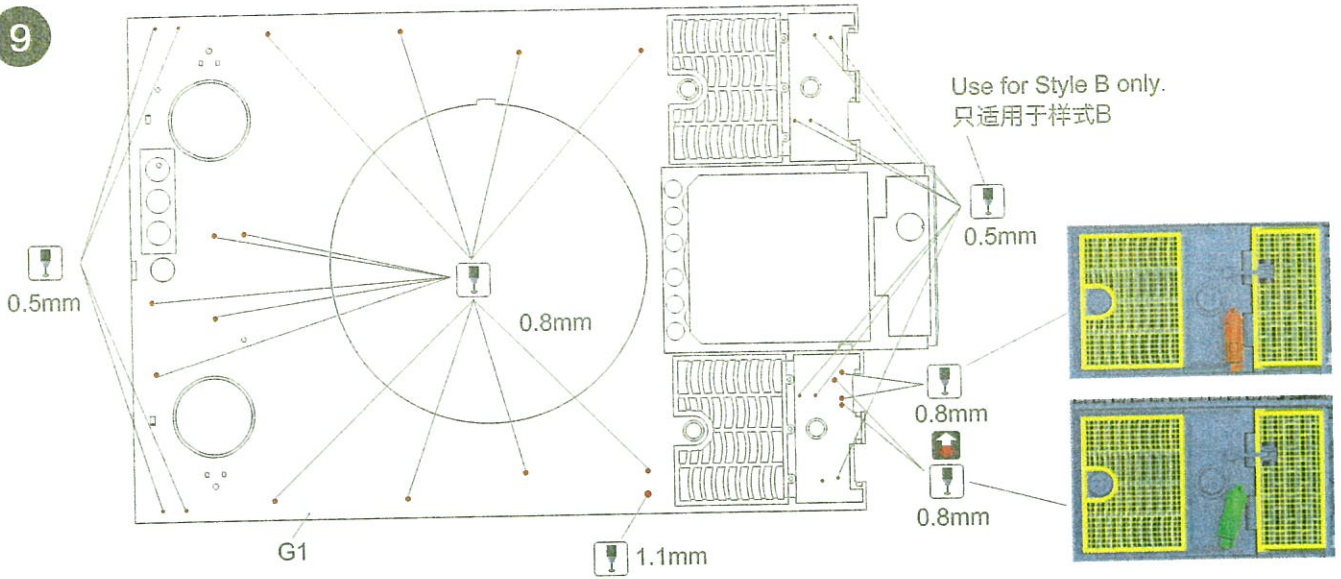

10

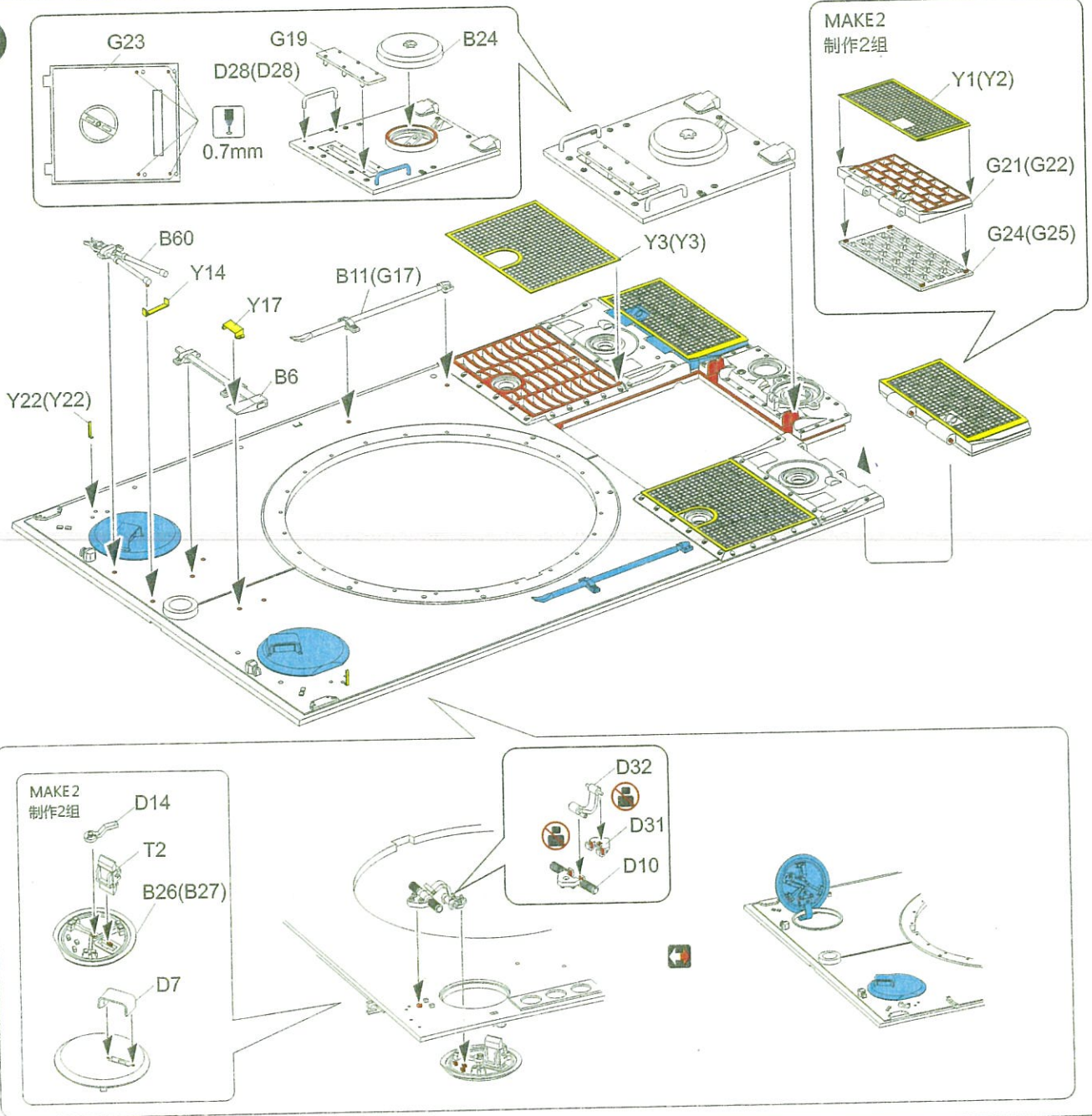

11

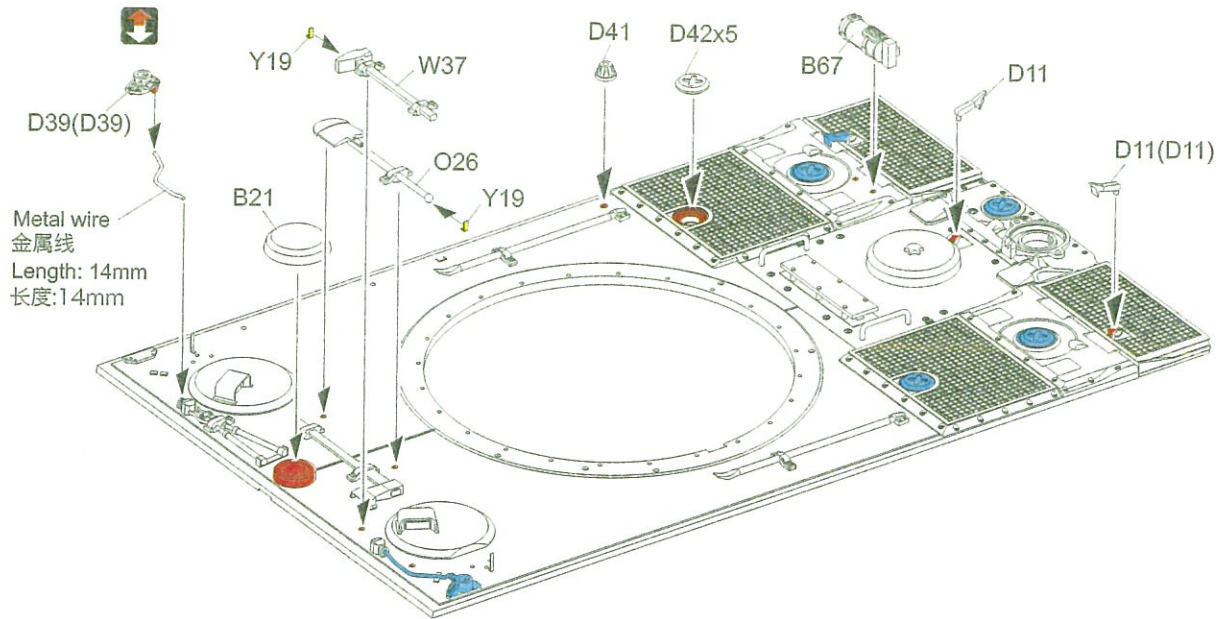
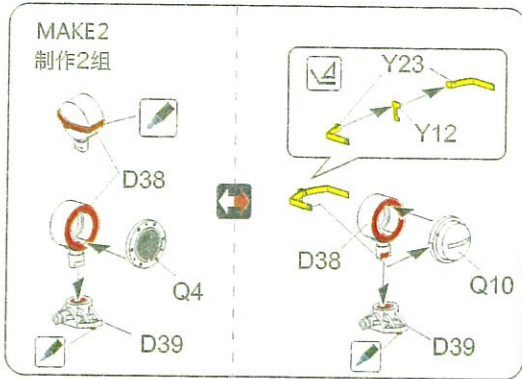

12

Style A
样式A

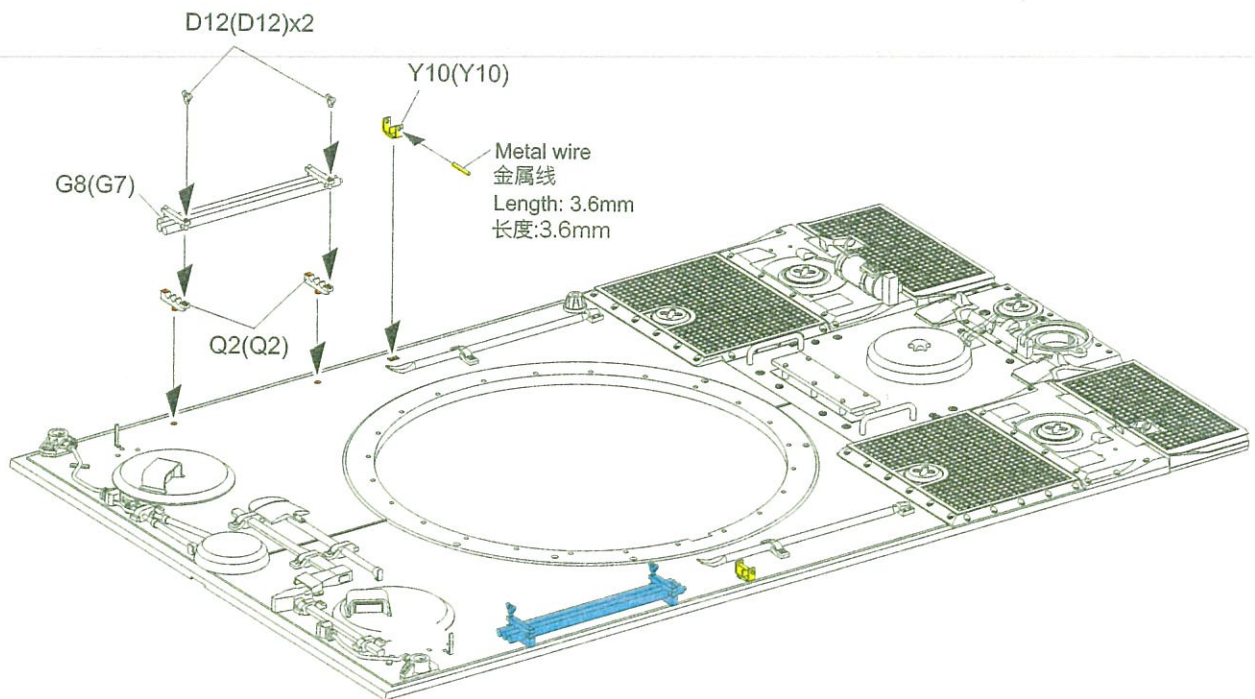

Style B
样式B

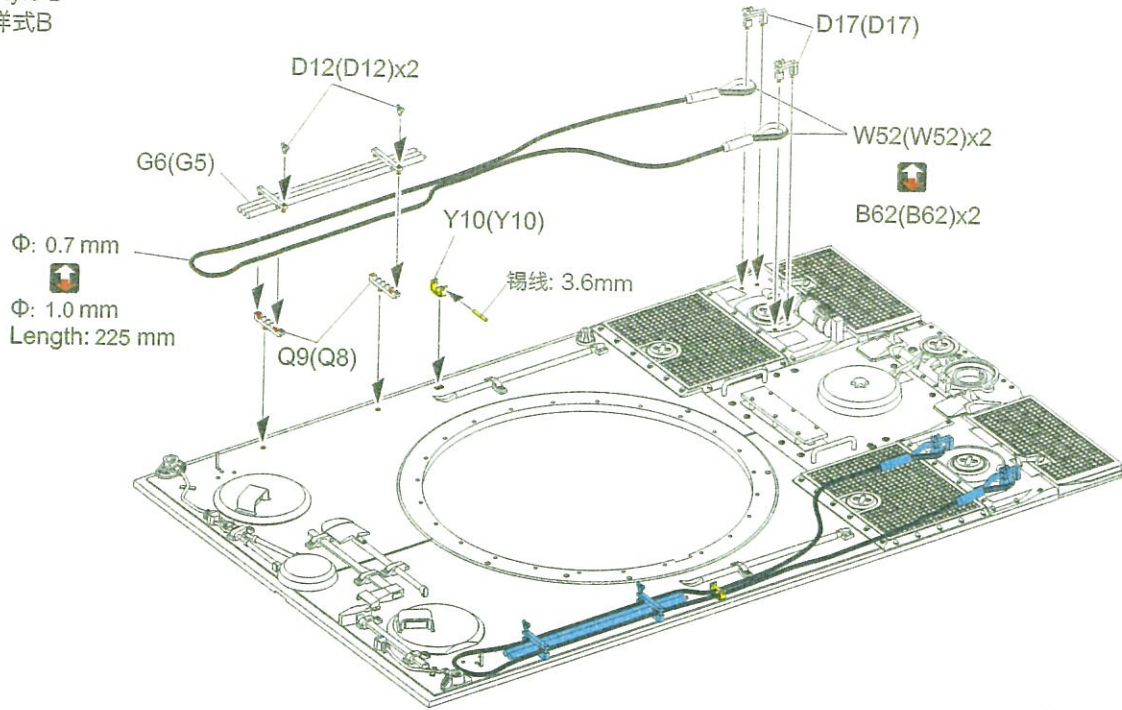

14

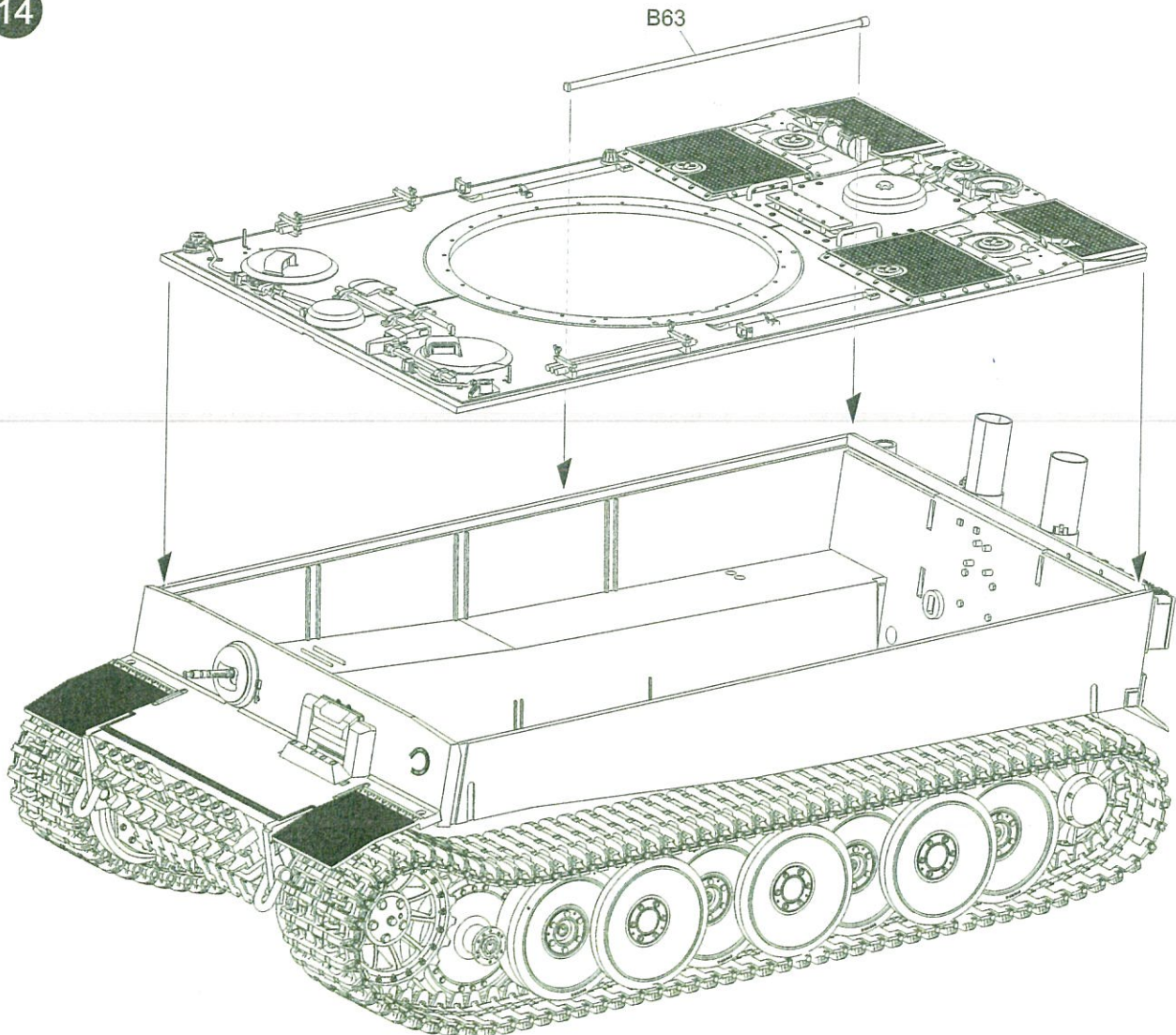

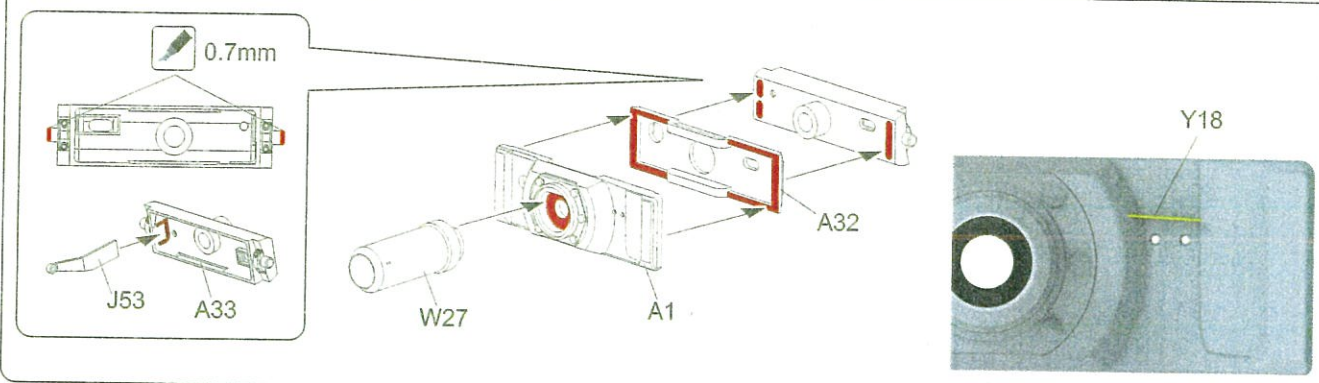

15

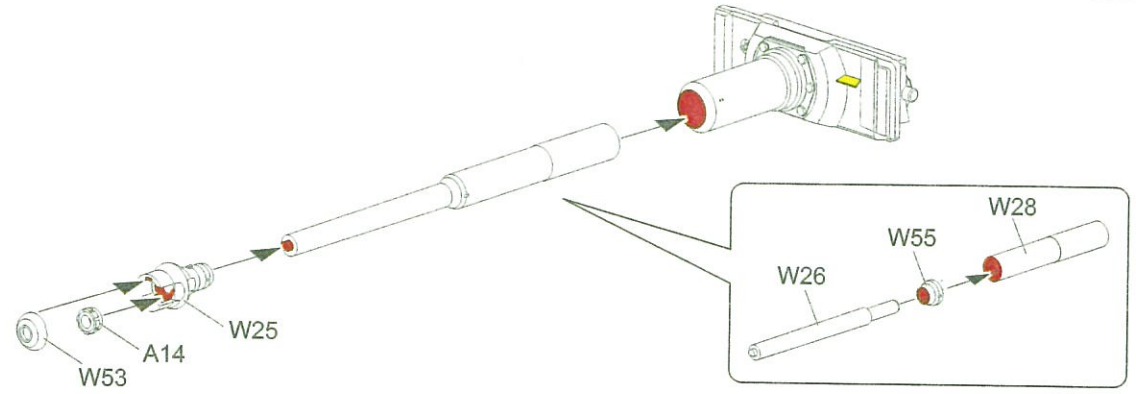

A2

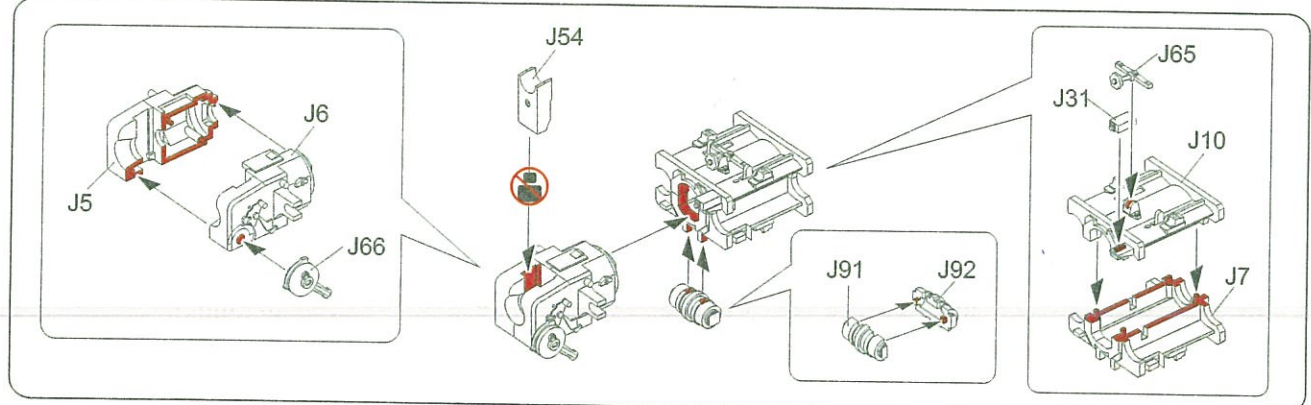

A3

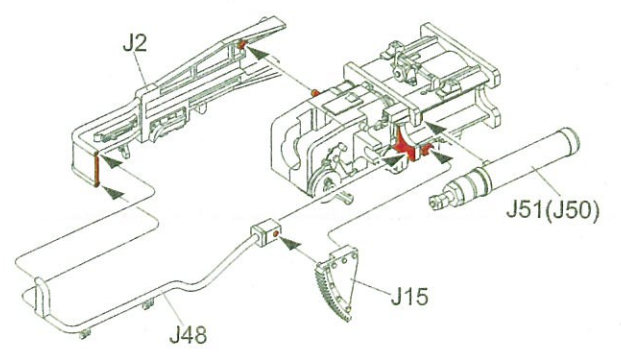
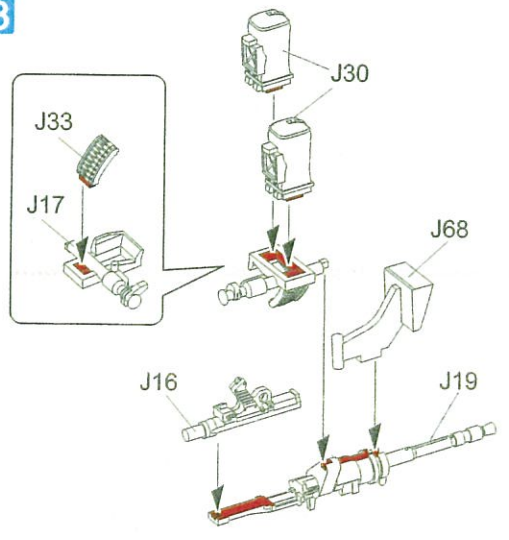

16

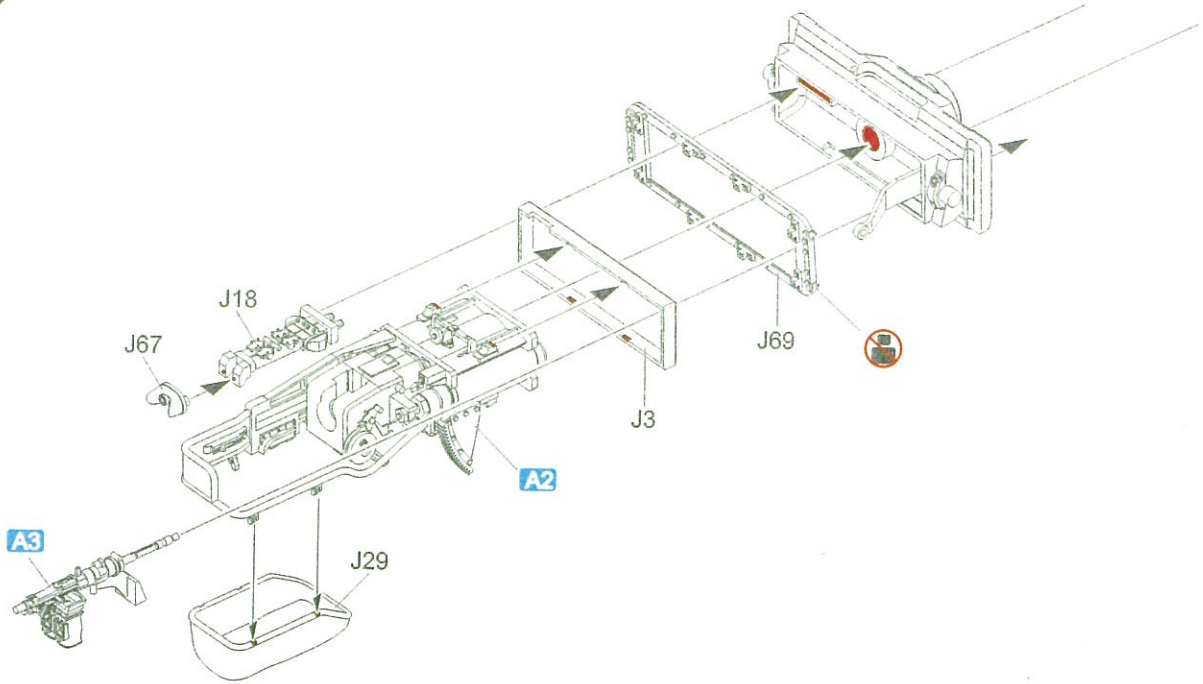

17

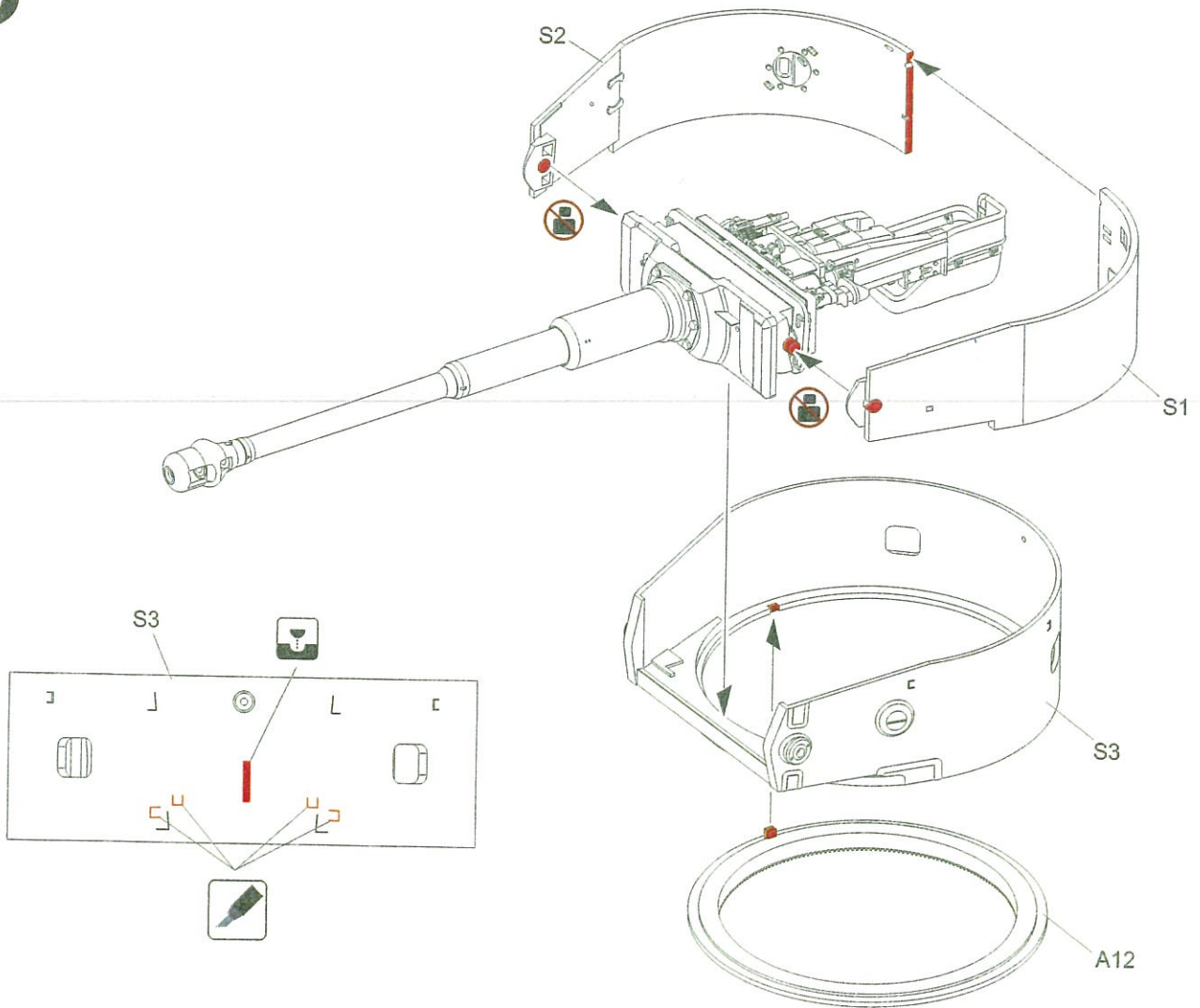

18

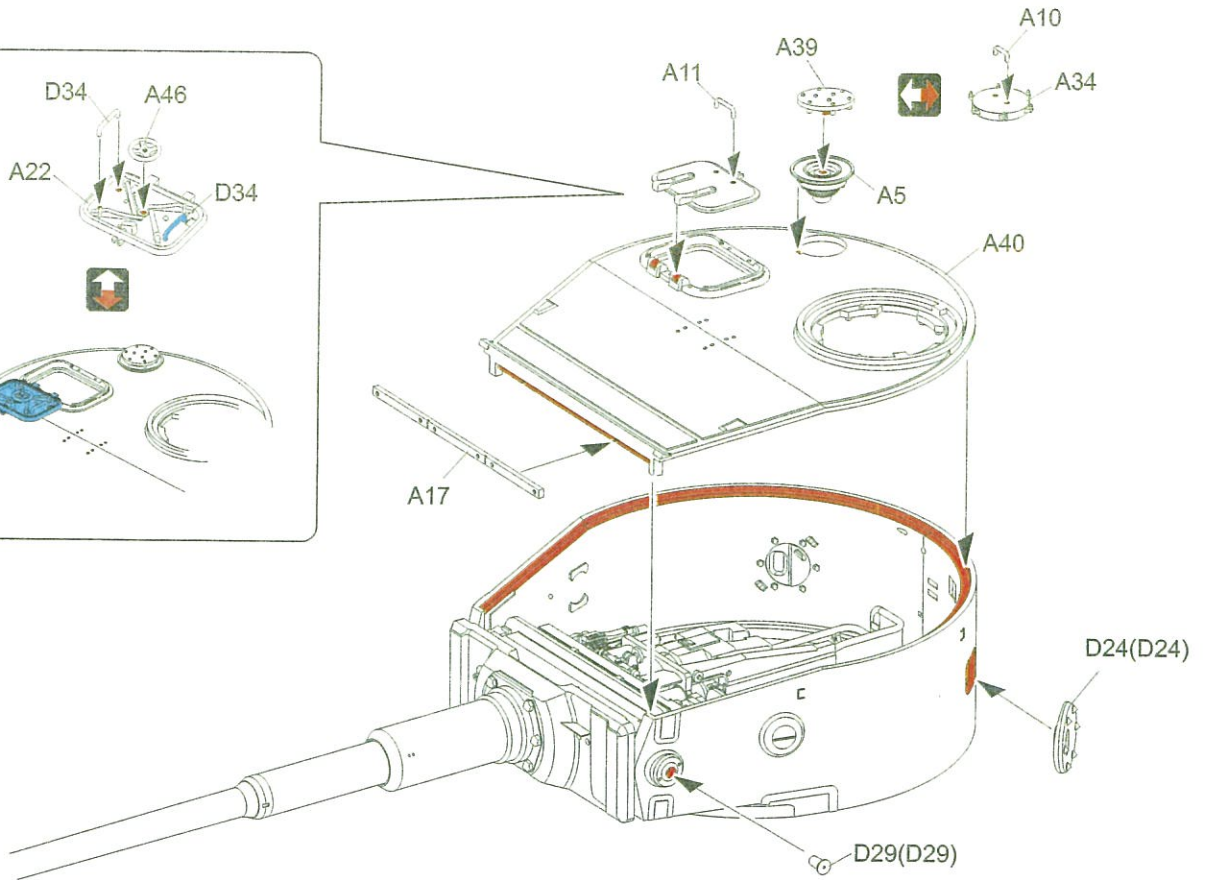
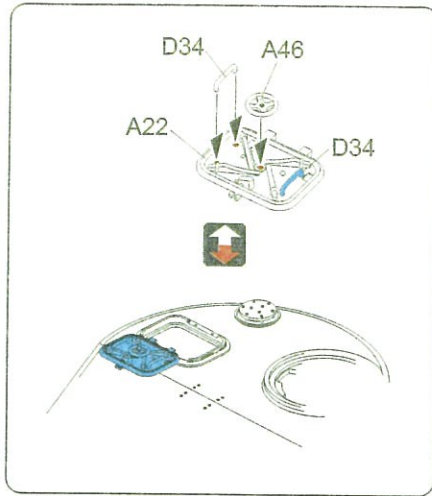

19

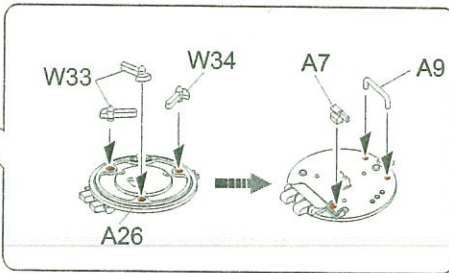
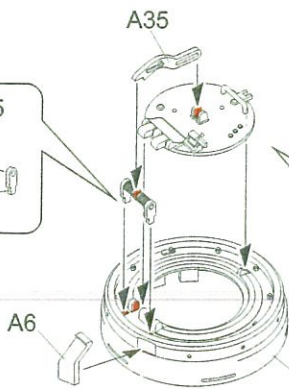
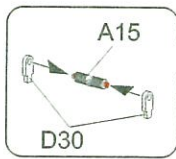

New Molded of One-piece cupola
全新一体式独立的指挥塔

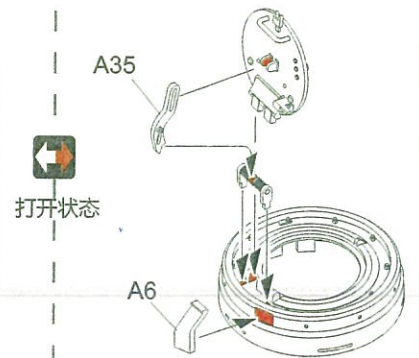

A4

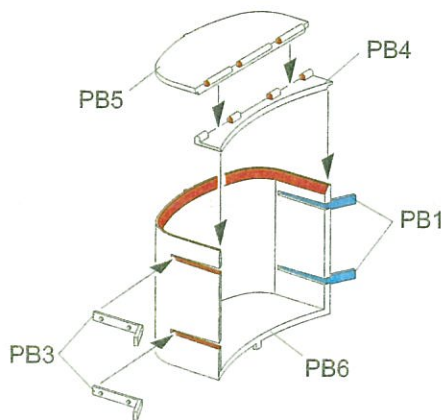

A5

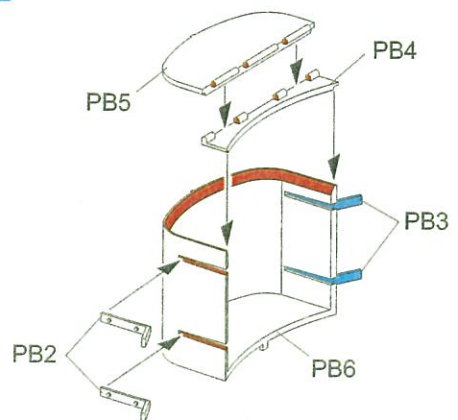

20

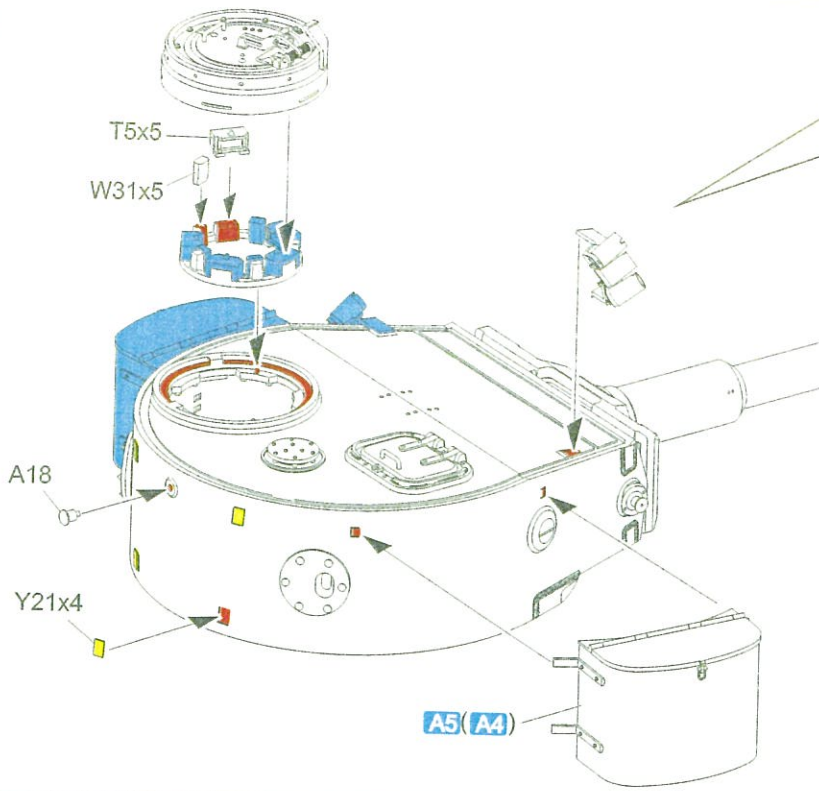

MAKE 2
制作2组

B28(B76)

D16x3

D4x3

Y9(Y9)

B49(B50)



3D打印件

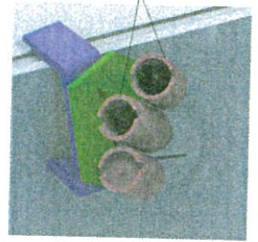

21

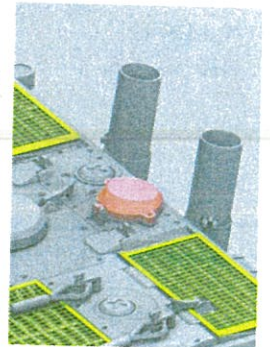
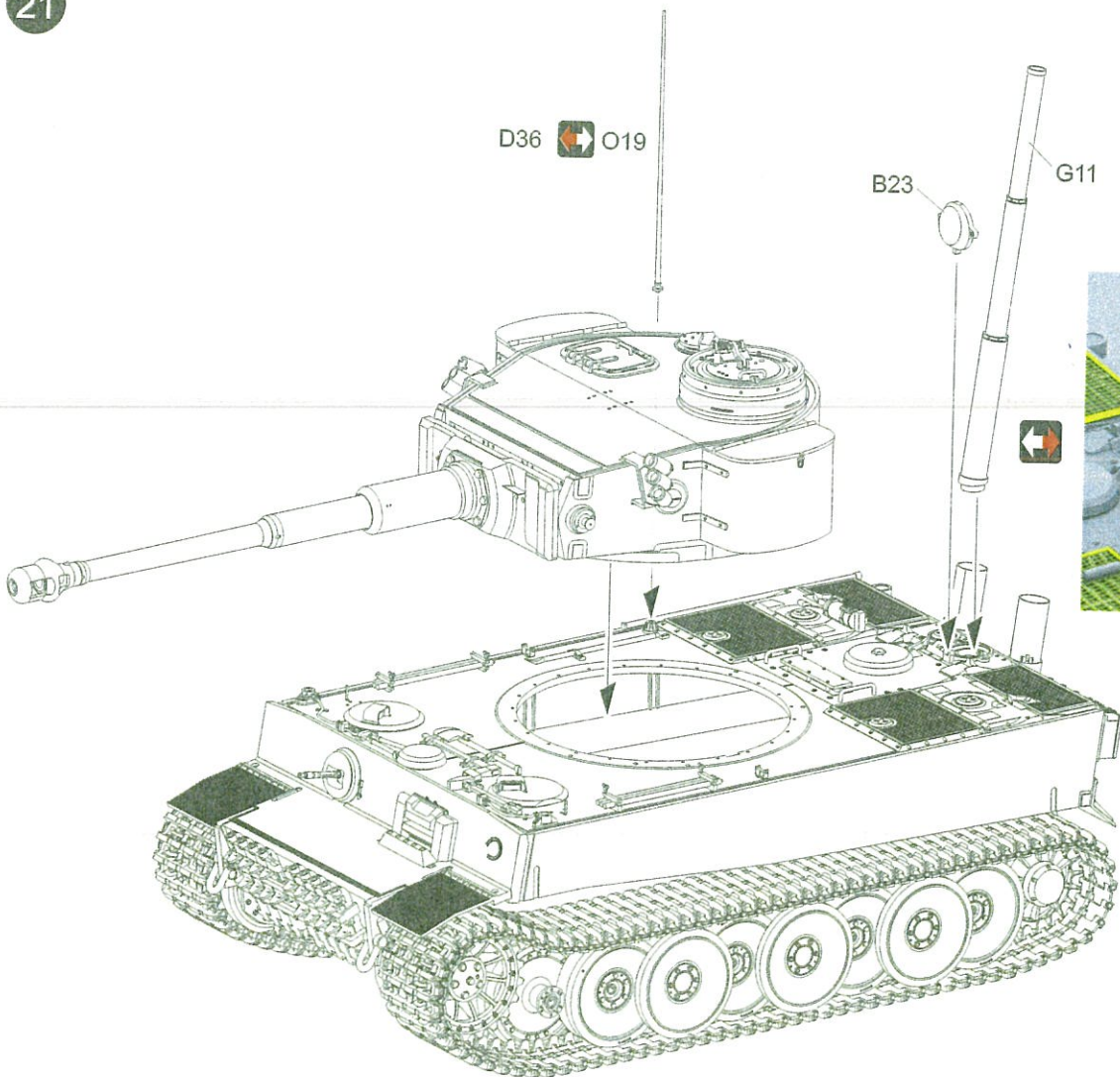

1/s PzAbt.502, near Leningrad, January 1943
 1943年1月, 列宁格勒, 502重装甲营

Color info and profiles
 by

