



Via Pradazzo, 6/b
40012 Calderara di Reno
Bologna - Italy
www.italeri.com

Conservare il presente
indirizzo per future
referenze

Retain this address
for future
reference

made in Italy

1:72 scale

No 1337



F-16[®] ADF/AM "Special Colors"

EN

In 1986, the USAF established the ADF (Air Defence Fighter) program in the course of which more than 270 F-16A/B Block 15 aircraft were upgraded to Block OCU aircraft and modified for the ANG departments. These planes had improved avionics and could be used with semi-active AIM-7 Sparrow radar-guided air-to-air missiles. The Italian Military Aeronautics Division leased 45 thousand hours of flight-time, between 2003 and 2010, for thirty F-16 Block 15 ADF aircraft upgraded to standard "Falcon Up" aircraft, and four F-16 Block 10 aircraft of converted operation. The work began on 28 June 2003, with the first F-16 landing at the Sicilian base, and on 22 May 2008 the aircraft of the 37th formation cut down 30,000 hours of flight-time.

IT

A partire dal 1986 l'USAF avviò il programma ADF (Air Defence Fighter), nel corso del quale oltre 270 F-16A/B Block 15 furono aggiornati in Block OCU e modificati per equipaggiare i reparti dell'ANG. Questi aerei avevano un'avionica ottimizzata ed erano compatibili con i missili a guida radar semiattiva AIM-7 Sparrow. L'Aeronautica Militare Italiana ha acquisito, in leasing, 45 mila ore di volo complessive da effettuare, dal 2003 al 2010, con 30 F-16 Block 15 ADF, aggiornati allo standard "Falcon Up", e quattro F-16 Block 10 da conversione operativa. L'attività è iniziata il 28 giugno 2003, con l'atterraggio nella base siciliana del primo F-16 e il 22 maggio 2008 i velivoli del 37° stormo hanno tagliato le 30.000 ore di volo.

DE

Seit 1986 startete die USAF das Programm ADF (Air Defence Fighter), im Verlauf dessen mehr als 270 F-16A/B Block 15 zu Block OCU aktualisiert und modifiziert wurden, um die Abteilungen der ANG auszurüsten. Diese Flugzeuge verfügten über eine optimierte Avionik und waren mit der semiaktiven radargesteuerten AIM-7 Sparrow - Rakete kompatibel. Die Italienische Luftwaffe hat im Leasingverfahren von 2003 bis 2010 insgesamt 45 Tausend vorzunehmende Flugstunden erworben; diese mit 30 F-16 Block 15 ADF, aktualisiert auf den Standard "Falcon Up", und vier F-16 Block 10 mit Konvertierung der Operativität. Die Aktivität begann am 28. Juni 2003 mit der Landung der ersten F-16 in der sizilianischen Basis, und am 22. Mai 2008 erreichten die Flugzeuge des 37. Geschwaders die 30.000 Flugstunden.

FR

A partir de 1986, l'USAF démarra le programme ADF (Air Defence Fighter) au cours duquel plus de 270 F-16A/B Block 15 furent actualisés en Block OCU et modifiés pour équiper les secteurs d'll'ANG. Ces avions avaient des instruments de bord optimisés et étaient compatibles avec les missiles à guidage radar semi-actif AIM-7 Sparrow. L'Aéronautique Militaire Italienne a acheté, en leasing, 45 mille heures globales de vol à effectuer de 2003 à 2010 avec 30 F-16 Block 15 ADF, actualisés au standard "Falcon Up", et quatre F-16 Block 10 de conversion opérationnelle. L'activité qui a commencé le 28 juin 2003, avec l'atterrage à la base sicilienne du premier F-16 et le 22 mai 2008 les avions de la 37ème formation ont franchi les 30.000 heures de vol.

ES

A partir de 1986, la Fuerza Aérea de los Estados Unidos puso en marcha el programa ADF (Air Defence Fighter), en el curso del cual más de 270 F-16A/B Block 15 fueron actualizados con el Block OCU y modificados para equipar las unidades d'll'ANG. Estos aviones tenían una aviónica optimizada y eran compatibles con los misiles con guía por radar semiactiva AIM-7 Sparrow. La Aeronáutica Militar Italiana adquirió en leasing 45 mil horas de vuelo totales que se efectuarían desde el 2003 al 2010, con 30 F-16 Block 15 ADF, actualizados para el estándar "Falcon Up", y cuatro F-16 Block 10 de conversión operativa. La actividad comenzó el 28 de junio de 2003 con el aterrizaje en la base siciliana del primer F-16 y el 22 de mayo de 2008 las aeronaves del 37° Stormo superaron las 30.000 horas de vuelo.

NL

Vanaf 1986 startte USAF het programma ADF (Air Defence Fighter) op, waarin naast 270 F-16A/B Block 15 worden bijgewerkt tot Block OCU en gewijzigd om de divisies van de ANG uit te rusten. Deze vliegtuigen beschikten over een geoptimaliseerde luchtvaartelektronica en waren compatibel met de semiactieve radargeleide raketten AIM-7 Sparrow. De Italiaanse Militaire Luchtvaart heeft in leasing 45 miljoen in totaal 45 miljoen vlieguren verworven, uit te voeren van 2003 tot 2010, met 30 F-16 Block 15 ADF, bijgewerkt naar de standaard "Falcon Up", en vier F-16 Block 10 met werkzame conversie. De actie begin op 28 juni 2003, met de landing op de Siciliaanse basis van de eerste F-16; op 22 mei 2008 hebben de vliegtuigen van de 37e stormtroep de kaap van 30.000 vlieguren overschreden.



- EN WARNING:** Model for adult collector age 14 and over
IT ATTENZIONE: Modello per collezionisti adulti di età superiore ai 14 anni
FR ATTENTION: Modèle pour modélistes de 14 ans et plus.
DE ACHTUNG: Modellbausätze Für Modellbauer über 14 Jahre.
NL WAARSCHWING: Geschikt voor 14 jaar en ouder.
ES ATENCION: Modelo para modelistas mayores de 14 años.



LOCKHEED MARTIN[®], F-16[®] ADF/AM "Special Colors", associated emblems and logos, and body designs of vehicles are either registered trademarks or trademarks of the Lockheed Martin Corporation in the USA and/or other jurisdictions, used under license by Italeri S.p.A.

EN ATTENTION - Useful advice!

Study the instructions carefully prior to assembly. Remove parts from frame with a sharp knife or a pair of scissor and trim away excess plastic. Do not pull of parts. Assemble the parts in numerical sequence. Use plastic cement ONLY and use cement sparingly to avoid damaging the model. Black arrows indicate parts to be glued together. White arrows indicate on which frame the parts must be assembled WITHOUT using cement. These letters (A - B - C...) indicate on which frame the parts will be found. Paint small parts before detaching them from frame. Remove paint-where parts are to be cemented. Crossed out parts must not be used.

IT ATTENZIONE - Consigli utili!

Prima di iniziare il montaggio studiare attentamente il disegno. Staccare con molta cura i pezzi dalle stampe, usando un taglia-balsa oppure un paio di forbici e togliere con una piccola lima o con carta vetro fine eventuali sbavature. Mai staccare i pezzi con le mani. Montarli seguendo l'ordine delle numerazione delle tavole. Eliminare dalla stampata il numero del pezzo appena montato facendogli sopra una croce. Le frecce nere indicano i pezzi da incollare, le frecce bianche indicano i pezzi da montare senza colla. Usare solo colla per polistirolo. Le lettere (A - B - C...) ai lati dei numeri indicano la stampata ove si trova il pezzo da montare. I pezzi sbarrati da una croce non sono da utilizzare.

DE ACHTUNG - Ein nützlicher Rat!

Vor der Montage die Zeichnung aufmerksam studieren. Die einzelnen Montageteile mit einem Messer oder einer Schere vom Spritzling sorgfältig entfernen. Eventuelle Grate werden mit einer Klinge oder feinem Schmirgelpapier beseitigt. Keinesfalls die Montageteile mit den Händen entfernen. Bei der Montage der Tafelnummerierung folgen. Pfeile zeigen die zu klebenden Teile während die weissen Pfeile die ohne Leim zu montierenden Teile anzeigen. Bitte nur Plastikklebstoff verwenden. Die Buchstaben (A - B - C...) neben den Nummern zeigt auf welchem Spritzling der zu montierende Teil zu finden ist. Die mit einem Kreuz markierten Teile sind nicht zu verwenden.

FR ATTENTION - Conseils utiles!

Avant de commencer le montage, étudier attentivement le dessin. Détacher avec beaucoup de soin les morceaux des moules en usant un massicot ou bien un pair de ciseaux et couper avec une petite lame avec de papier de verre fin ébarbages éventuels. Jamais détacher les morceaux avec le mains. Monter les en suivant l'ordre de la numération des tables. Éliminer de la moule le numéro de la pièce qui vient d'être montée, en le bifant avec une croix. Les flèches noires indiquent les pièces à coller, les flèches blanches indiquent les pièces à monter sans colle. Employer seulement de la colle pour polystirol. Les lettres (A - B - C...) aux côtés des numéros indiquent la moule où se trouve la pièces à monter. Les pièces marquées par une croix ne sont pas à utiliser.

NL OPGELET - Belangrijke bemerkingen!

Bestudeer zorgvuldig het montageplan voor het bouwen. Breek nooit onderdelen van het kader. Maak ze los met een scherp mes of kleine nageltang. Verwijder daarna al het overloftige plastic en pas de delen alvorens te lijmen. Gebruik allen lijm voor plastic modellen. Werk zorgvuldig en spaarzaam, te veel lijm zal uw model beschadigen. Zwarte pijlen duiden de te lijmen delen aan. Witte pijlen verwijzen naar bewegende delen welke niet mogen worden gelijmd. Deze letters (A - B - C...) geven de kaders aan waarin de onderdelen zich bevinden. Schilder de kleine onderdelen voor ze van het kader te snijden. Verwijder de verf van de te lijmen oppervlakten.

ES ATENCION - Consejos útiles!

Estudiar las instrucciones cuidadosamente antes de comenzar el montaje. Separar las piezas de las bandejas con un cuchillo afilado o un par de tijeras y retirar el exceso de plástico o rebada. No arrancar las piezas. Montar las piezas en orden numérico. Utilizar SOLAMENTE pegamento para plástico y en poca cantidad para evitar que se dane el modelo. Las flechas negras indican las piezas que se deben pegar juntas. Las flechas blancas indican las piezas que deben ensamblarse SIN usar pegamento. Las letras (A - B - C...) indican en que bandeja se encuentran las piezas. Pintar las piezas peguenas antes de separarlas de la bandeja. Retirar la pintura de los lugares por donde se deban pegar las piezas.

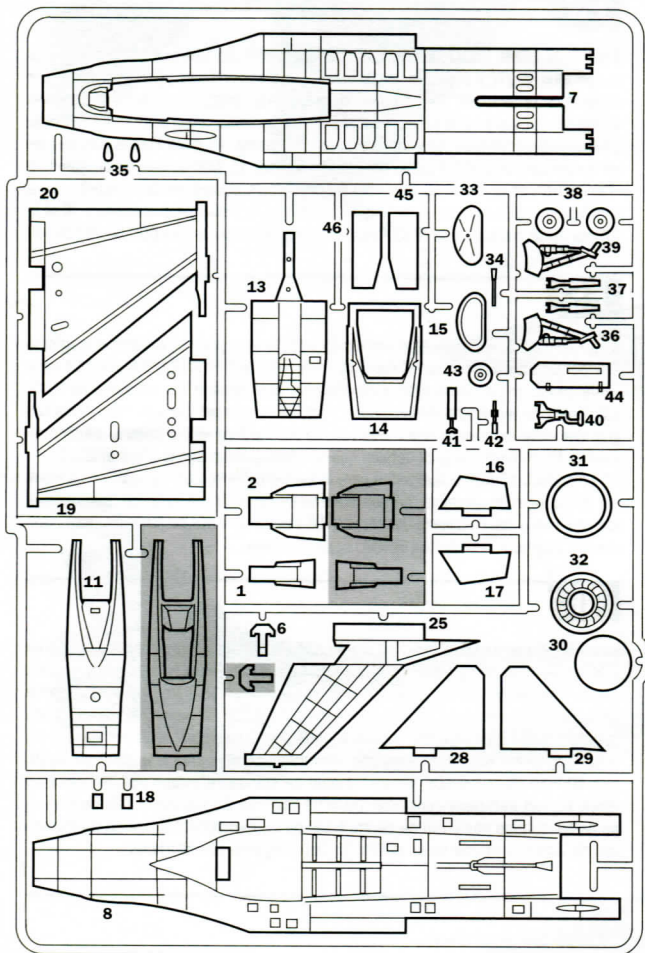
**A**

AGGIUNGERE ZAVORRA (PESO)
INSERT BALLAST
BALLAST ZUGEBEN
A LESTER

Parts not for use
Telle werden nicht verwendet
Parti da non utilizzare
Pièces à ne pas utiliser

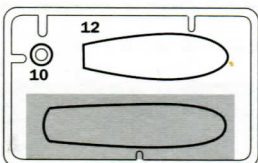
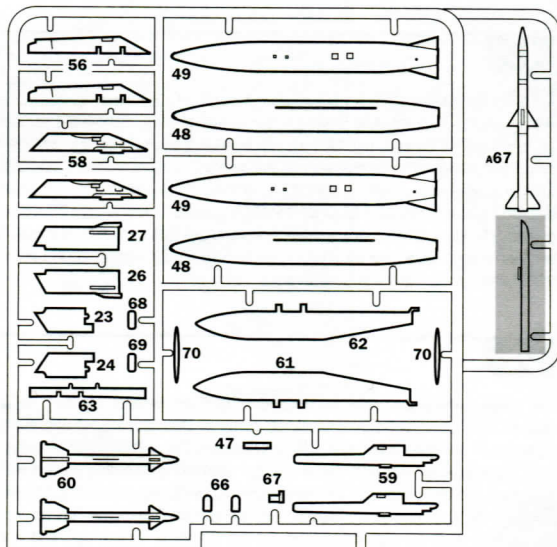
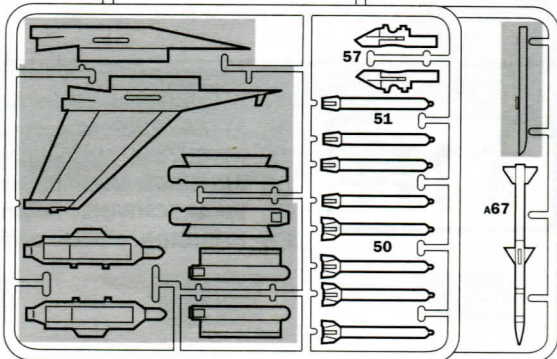
**C****B**

I numeri si riferiscono all'assortimento colori ITALERI ACRYLICPAINT
 The indicated colour numbers refer to the ITALERI ACRYLICPAINT
 Die angegebenen Farbnummern beziehen sich auf die ITALERI ACRYLICPAINT
 Les références indiquées concernent les peintures ITALERI ACRYLICPAINT

A

FLAT DARK GULL GRAY
F.S. 36231

ITALERI ACRYLICPAINT - 4755AP

B

GLOSS RED
F.S. 11302

ITALERI ACRYLICPAINT - 4605AP

C

FLAT GULL GRAY
F.S. 36622

ITALERI ACRYLICPAINT - 4763AP

D

FLAT BLACK
F.S. 37038

ITALERI ACRYLICPAINT - 4768AP

E

GLOSS WHITE
F.S. 17875

ITALERI ACRYLICPAINT - 4696AP

F

FLAT DARK GHOST GRAY
F.S. 35237

ITALERI ACRYLICPAINT - 4761AP

G

METAL GLOSS SILVER
F.S. 17178

ITALERI ACRYLICPAINT - 4678AP

H

GLOSS GREEN
F.S. 14090

ITALERI ACRYLICPAINT - 4669AP

I

FLAT GUN METAL
F.S. 37200

ITALERI ACRYLICPAINT - 4681AP

L

FLAT OLIVE DRAB
F.S. 34084

ITALERI ACRYLICPAINT - 4728AP

M

FLAT LIGHT GHOST GRAY
F.S. 36300

ITALERI ACRYLICPAINT - 4762AP

1

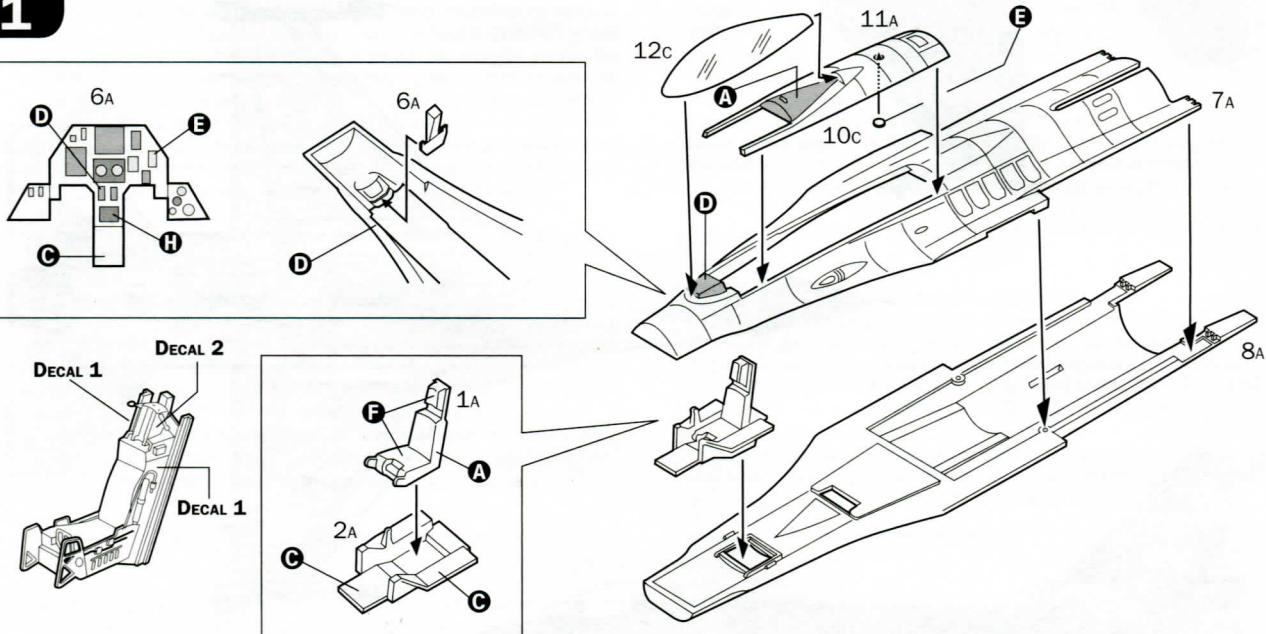

2

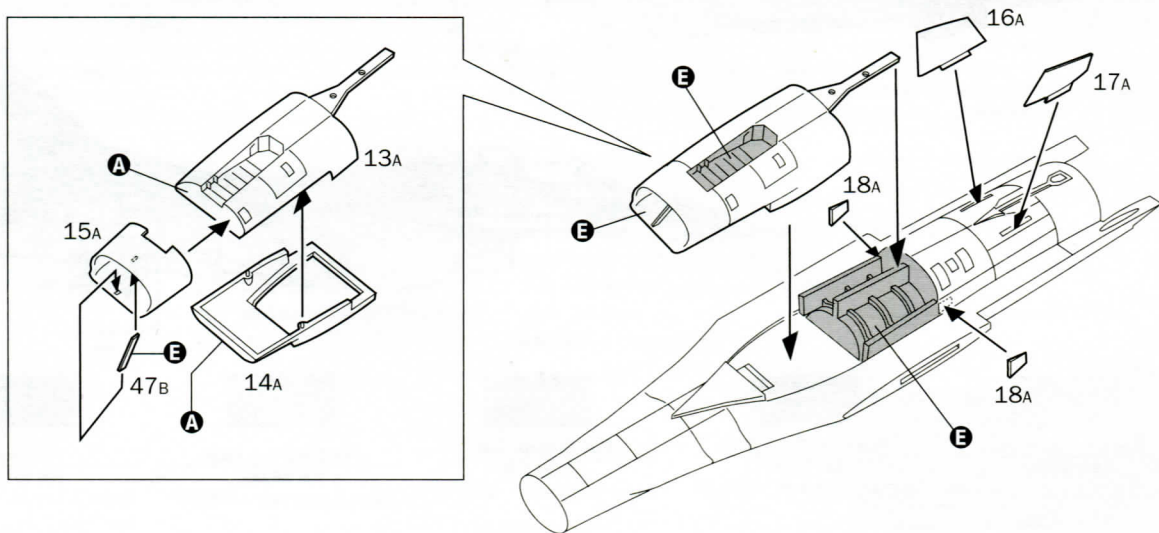

VERSIONS B-C ONLY

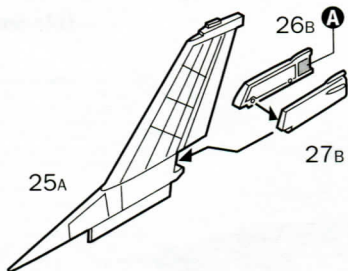

VERSION A ONLY

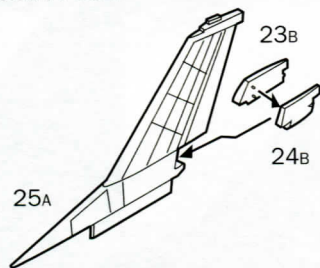

VERSION A ONLY

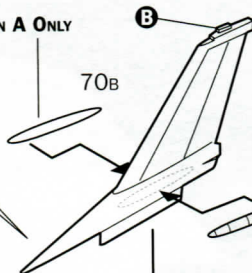

VERSION A ONLY

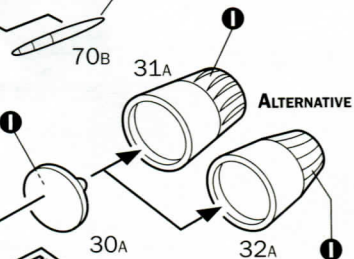

ALTERNATIVE

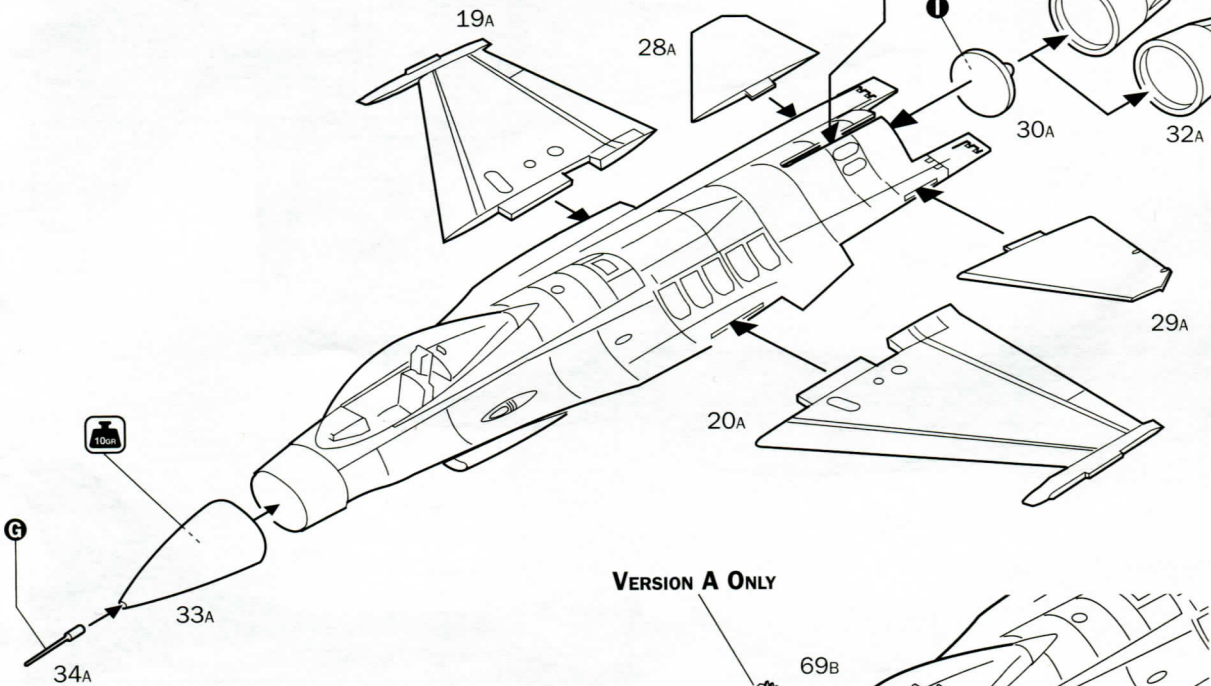

VERSION A ONLY

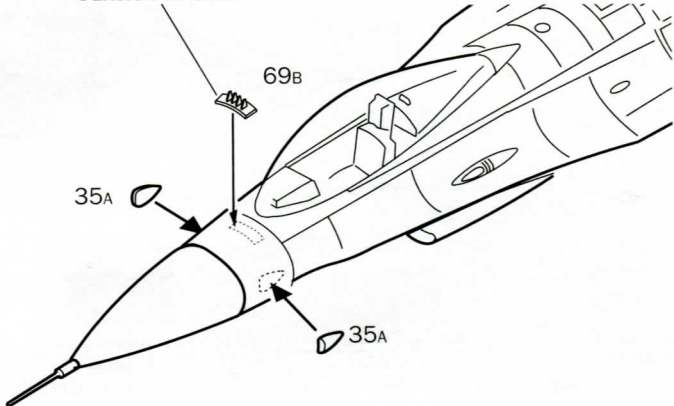

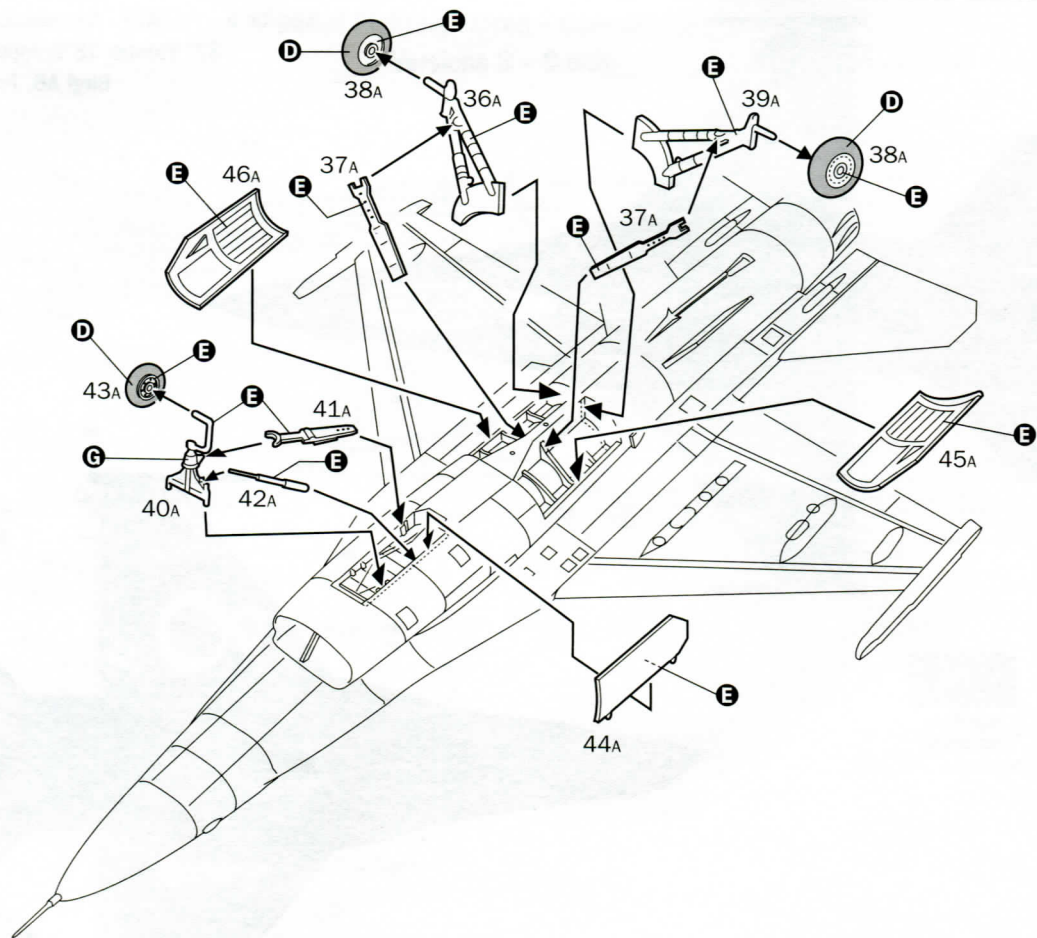
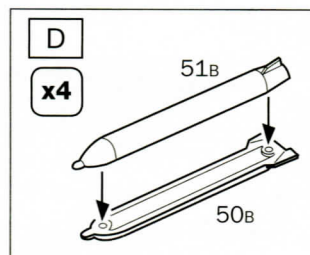
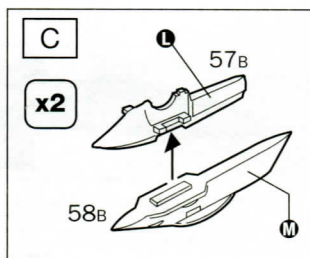
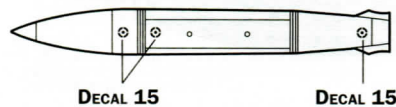
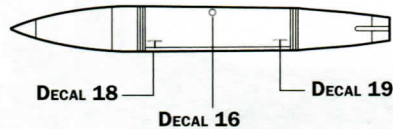
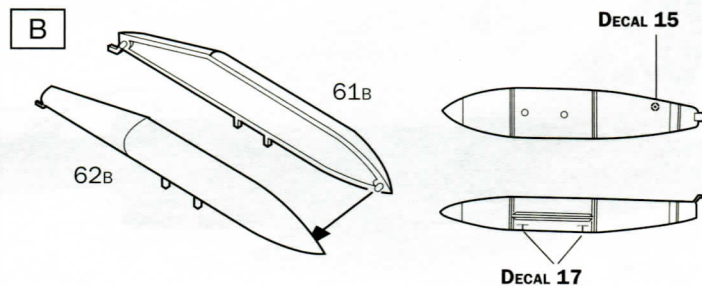
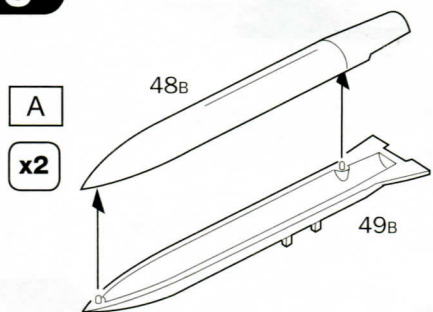
4**5**

INNER WING PYLON

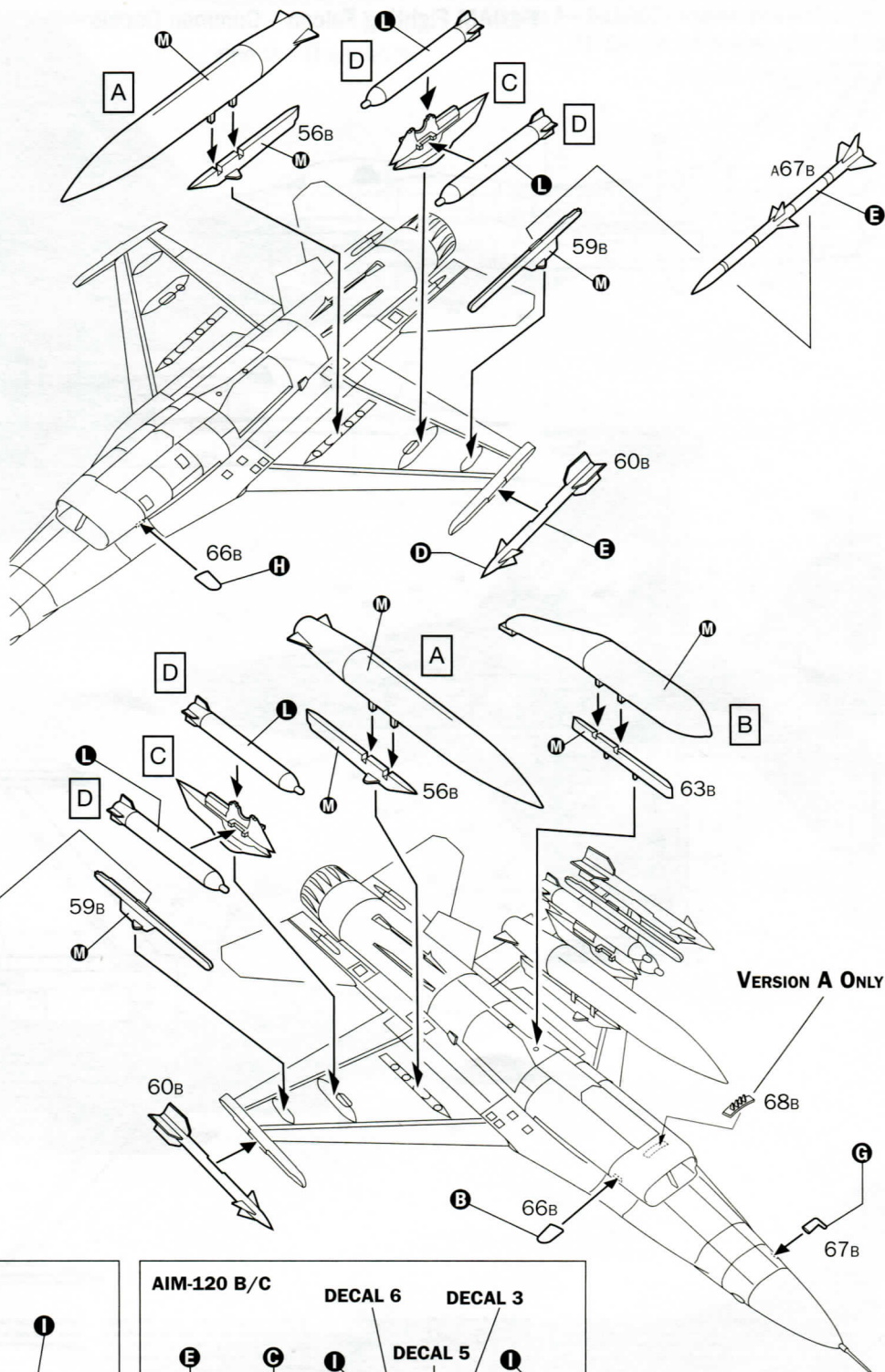
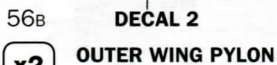
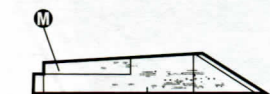
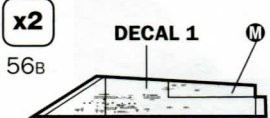

AIM-9M x2

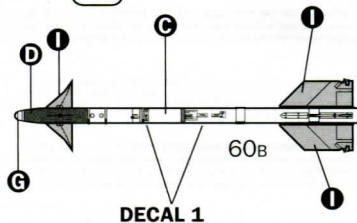

AIM-120 B/C

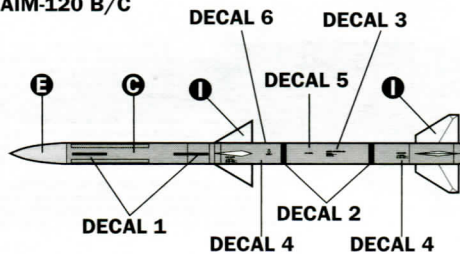

F-16AM Fighting Falcon – Common Decals

Versions B – C only

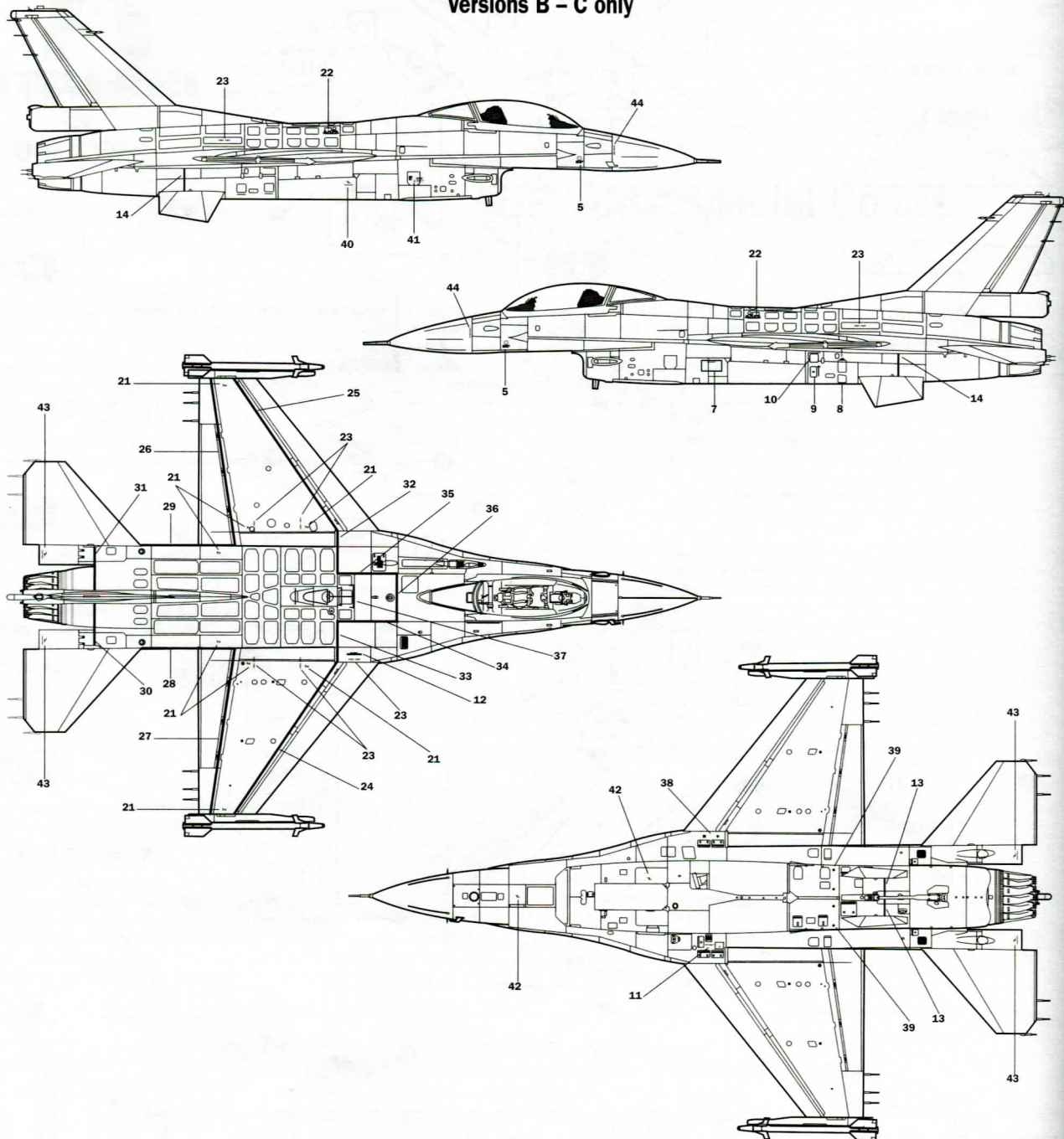

Istruzioni per l'applicazione delle decalcomanie. Ritagliare le decalcomanie occorrenti dal foglio, immergerle in un bicchiere di acqua pulita per circa 10", metterle in posizione sul modello e farle scivolare dalla carta: per una migliore aderenza comprimerle con una pezzuola pulita.

Direction for applying the decals: cut the required decals out of the sheet; dip the into a glass of clean water for about 10"; position the decals on the kit, letting them slide from the paper. For a better adesion, press them by means of a clean rag.

Påslättning av decalor: klipp ut den decal som skall användas och doppa den i ett glas vatten under en 10". Slätt decalen på plats på modellen och låt den sakta glida av pappret. För att den skall sitta ordentligt, tryck till med en torr duk.

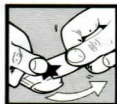

Anweisungen für Abziehbilder-Anbringung: Die benötigten Abziehbilder vom Blatt abscheiden, in ein Glas reines Wasser für etwa 10" eintauchen, auf das Modell legen und dann vom Papierbogen abnehmen. Um eine bessere Haftung zu erzielen, die Abziehbilder mit einem reinen Tuch andrücken.

Instruction pour l'application des décalcomanies. Couper les décalcomanies choisies et les plonger environ 10" dans un peu d'eau propre. Les placer sur le modèle en les faisant glisser de leur feuille et presser avec un morceau de chiffon pour éliminer les bulles d'air.

Instrucciones Para la aplicación de las calcomanías: cortar las requeridas, sumergirlas en un recipiente de agua limpia durante 10", colocar las calcomanías sobre el modelo, haciéndolas deslizar sobre el papel. Para una mayor adherencia, presionarlas con un trapito limpio.

Transfers: knip het benodigde deel uit, dempel et ca. 10" onder water, oudt het transfer tegen het model en schuif het vanaf het papier op zijn plaats. Met een schoon doekje aandrukken.

デカール取用法: 図表から、それぞれのマークを切り取ります。ぬるま湯に約10分浸して、ゆるやかに模型に押し当て、紙から剥がしてください。剥がした後は、きれいな布で押し当てて空気を除去してください。マークには、かわるまで手をふれないでください。

Указания по применению декалей: Отрежьте нужную вам часть декалей от общего листа, погрузите ее на 1/2 минуты в чистую воду; затем, выбрав необходимое место на модели, переведите гуд изображение, сдвинув его с бумажной основы. Для лучшего прилипания промокните декаль чистой тряпкой.

Version A - F-16ADF - Aeronautica Militare Italiana
 37° Stormo, 18° Gruppo/CIO, 1000 hours
 Birgi AB, Trapani, Sicily, 2009

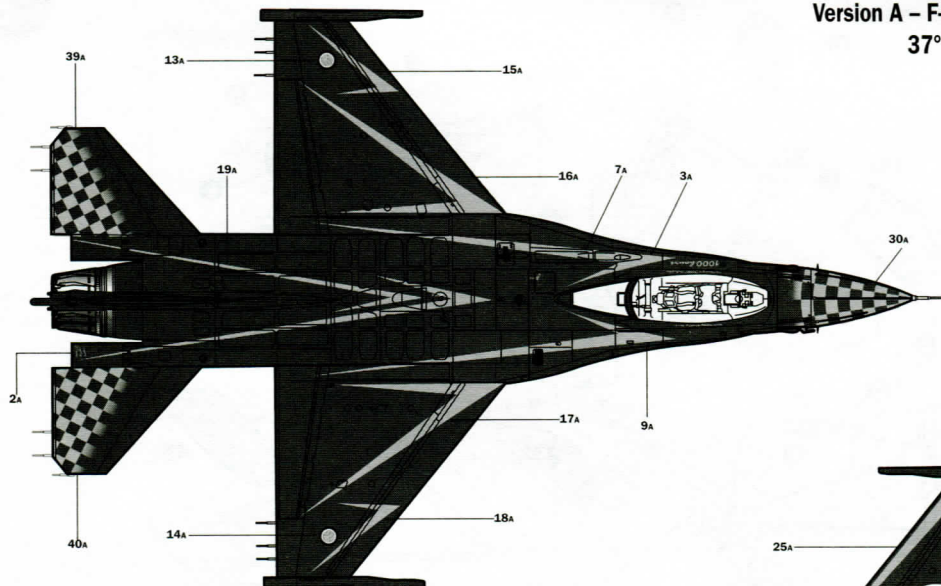

FLAT BLACK
F.S. 37038
 ITALERI ACRYLICPAINT - 4768AP

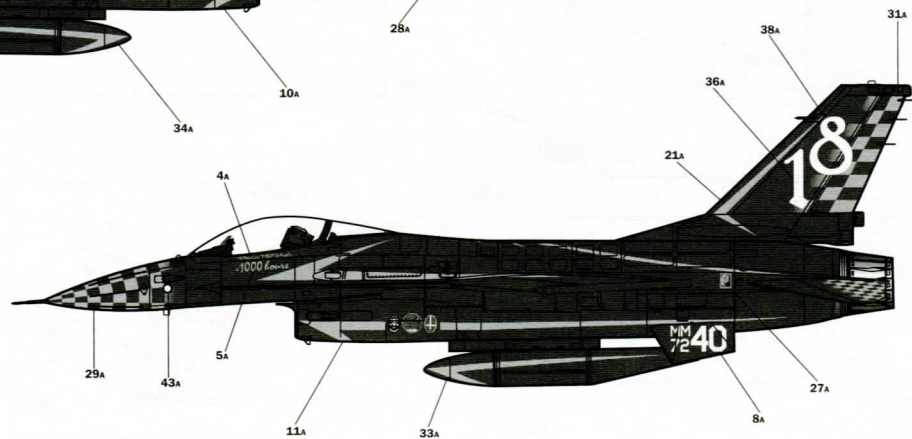
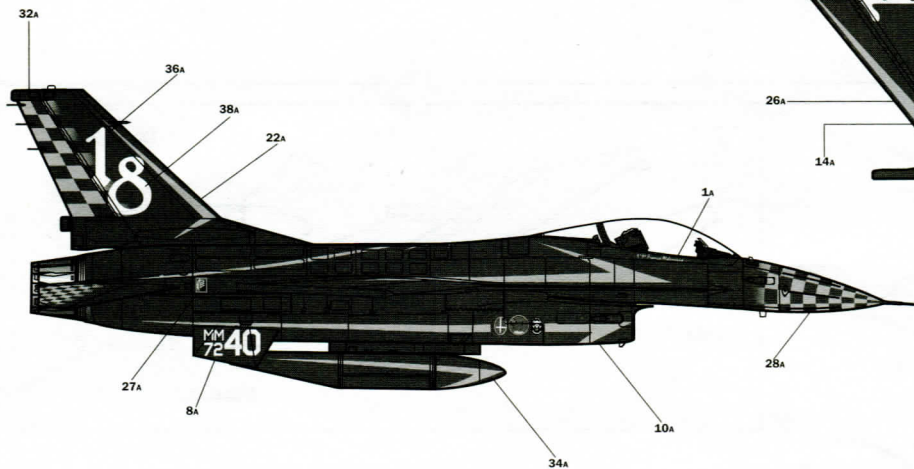
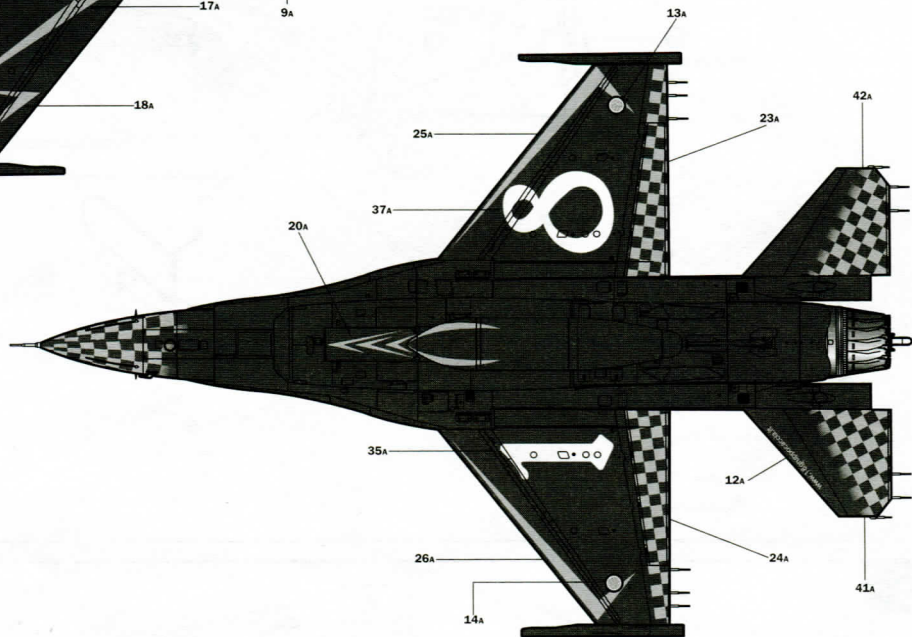

Version B - F-16 AM - Belgian Air Component
 2 Wing, 1ère Escadrille/
 1ste Smaldeel "Chardon", 90 years
 Florennes AB, Belgium

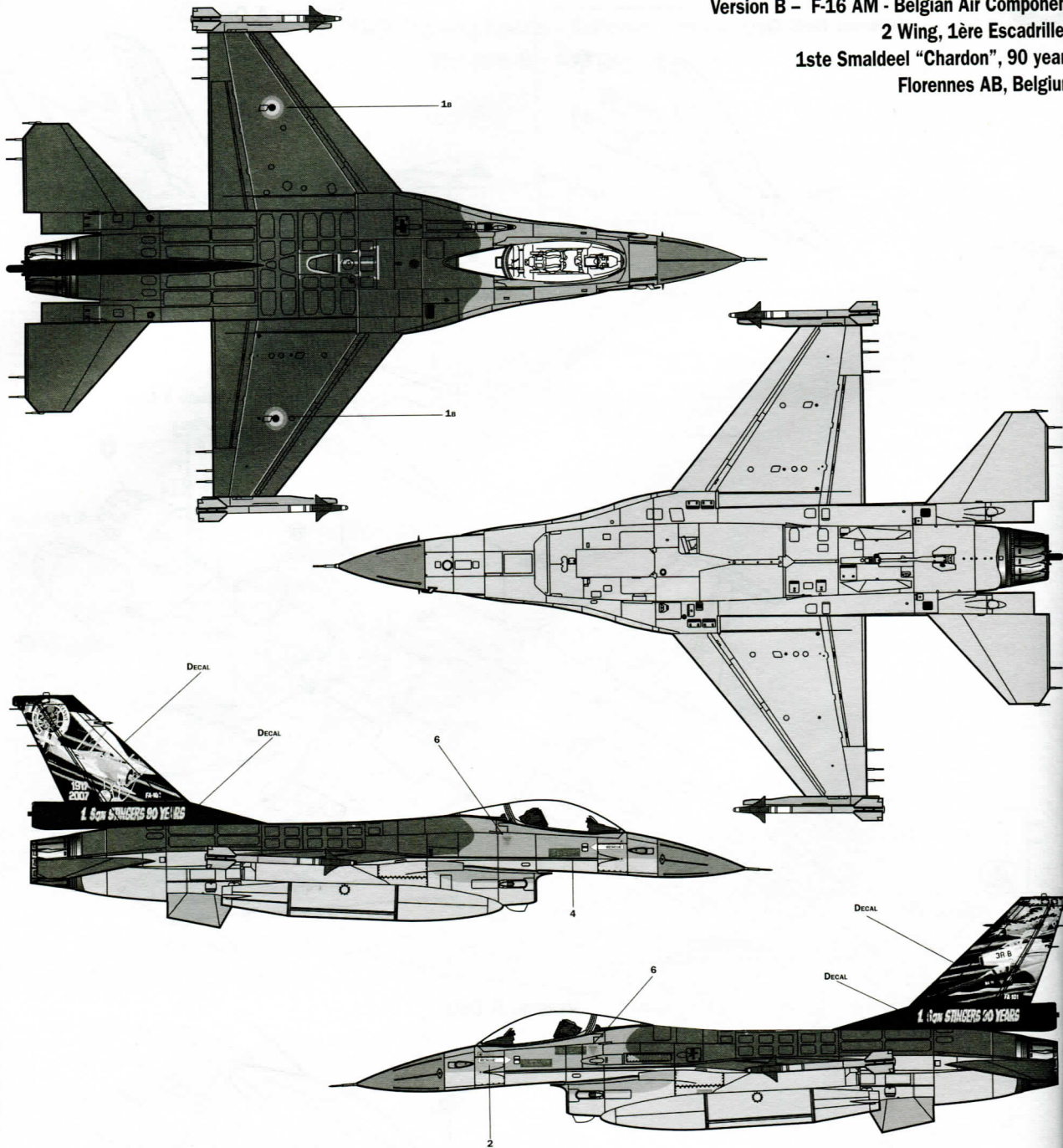

FLAT LIGHT GHOST GRAY
 F.S. 36300

ITALERI ACRYLCPAINT - 4762AP



FLAT DARK GHOST GRAY
 F.S. 35237

ITALERI ACRYLCPAINT - 4761AP



FLAT GUNSHIP GRAY
 F.S. 36118

ITALERI ACRYLCPAINT - 4752AP



FLAT DARK GULL GRAY
 F.S. 36231

ITALERI ACRYLCPAINT - 4755AP



FLAT BLACK
 F.S. 37038

ITALERI ACRYLCPAINT - 4768AP

Version C – F-16 AM - Koninklijke Luchtmacht
 1st Fighter Wing, 313 sqn "Tigers"
 55 years, Volkel AB, Twenthe, NL, 2008

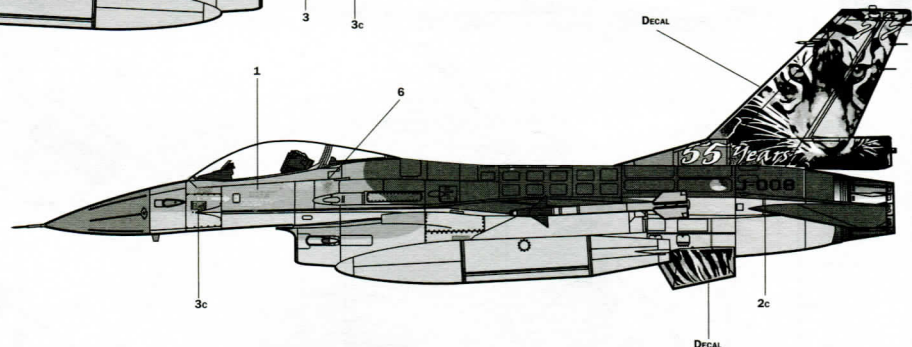
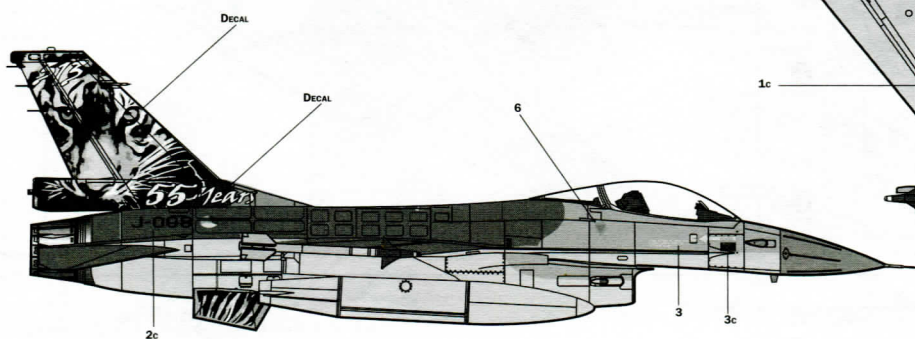
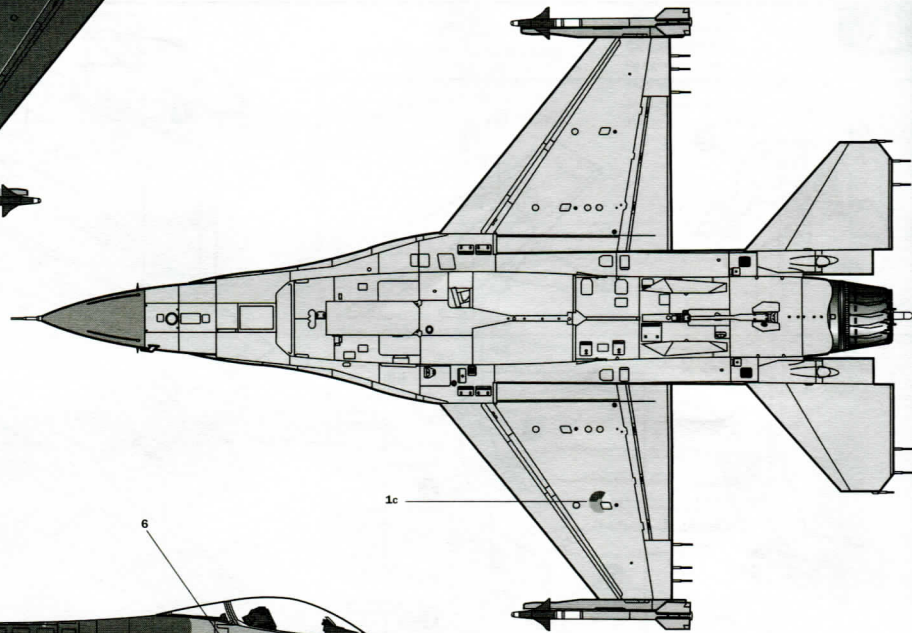
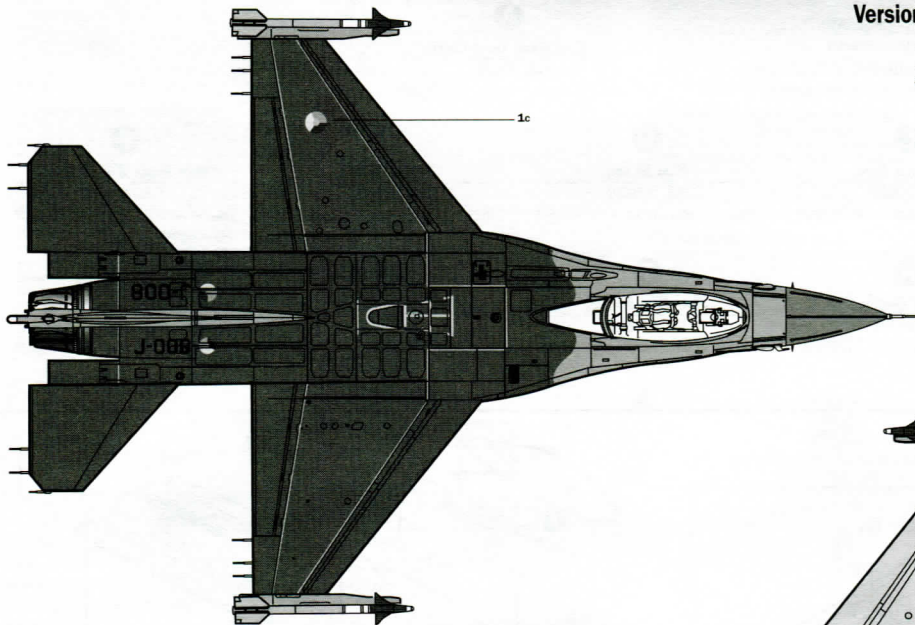

FLAT LIGHT GHOST GRAY
 F.S. 36300
 ITALERI ACRYLICPAINT – 4762AP



FLAT DARK GHOST GRAY
 F.S. 35237
 ITALERI ACRYLICPAINT – 4761AP



FLAT GUNSHIP GRAY
 F.S. 36118
 ITALERI ACRYLICPAINT – 4752AP



FLAT DARK GULL GRAY
 F.S. 36231
 ITALERI ACRYLICPAINT – 4755AP



FLAT BLACK
 F.S. 37038
 ITALERI ACRYLICPAINT – 4768AP