



워리어 MCV "2003 이라크전"

Warrior Mechanized Combat Vehicle was developed in mid-1970s by GKN Defence for the British Army. In 1978 a parallel evaluation of the American M2 Bradley IFV took place, the following year full development of the Warrior started in parallel with continued study of the M2 Bradley. Production of Warrior began in January 1986 with first production vehicles completed in the December. It was officially handed over to the British army May 1987. The total requirement was for 1,053 vehicles and by late 1994 over 789 vehicles had been delivered to the British Army. Eight mechanized infantry battalions will now be equipped with the Warrior in service only with British Army, two in the UK and six in Germany. The hull of Warrior is of all-welded aluminum construction with well sloped glances plate. The engine is a Perkins CV8 TCA V8 diesel developing 550hp at 2,300rpm which is coupled to an American Allison X300-4B transmission, manufactured under licence in the UK by Perkins Engines. And the turret of Warrior has vertical sides with long barrel 30mm RARDEN cannon with 7.62mm L94A1 Chain Gun and mounted in external mantlet. For operations in the Middle East and Bosnia-Herzegovina, the Warrior was fitted with additional armor protection.

Der als WARRIOR MCV bezeichnete Infanterie Panzer wurde in der Mitte der 1970er Jahre von der Firma GKN Defence für die britische Armee entwickelt. 1978 fanden parallel dazu Versuchsreihen mit dem amerikanischen M2 Bradley IVF statt. Nach eingehenden Tests wurde das Fahrzeug 1984 für den Truppendienst zugelassen, die Produktion begann im Januar 1986 und die ersten Panzer kamen Anfang 1987 zur Truppe. Die geplante Gesamtanzahl waren 1053 Stück und Ende 1994 waren über 789 Fahrzeuge ausgeliefert. Der WARRIOR ist eine komplett geschweißte Aluminium Konstruktion mit stark geneigter Frontplatte. Als Antrieb arbeitet ein Perkins CV8 TCA V8 Dieselmotor mit 550 PS bei 2300 upm zusammen mit einem Allison X300-4B Getriebe, welches in England unter Lizenz bei Perkins gefertigt wird. In Turm befindet sich eine langläufige 30mm L21A1 Kanone nebst 7,62mm L94A1 MG. Die dreiköpfige Besatzung kann den 27 Tonnen schweren WARRIOR auf ca. 75 km/h beschleunigen und dabei sieben Infanteristen befördern. Für Einsätze im nahen Osten oder Bosnien wurden zusätzliche Panzerschürzen angebracht.

ウォーリア(Warrior)戦闘機甲車は、英国陸軍用としてGKN Defence社により1970年代中頃に開発されました。1978年米国のM2型ブラッドレイ歩兵戦闘軍両についての評価も並行して行われました。1979年、M2型ブラッドレイ歩兵戦闘軍両についての評価も並行して継続しつつ、ウォーリアの全面開発が開始されました。ウォーリアの生産は1986年1月にはじまり、最初の生産の完成された車両が出たのは同年12月でした。ウォーリアは、1987年5月に、英国陸軍に対し公式に引き渡されました。要求総数は1053台で、1994年後期までに、789台以上のウォーリアが英国陸軍に引き渡されました。8つの機甲歩兵大隊、英国在の2ヶ大隊及びドイツ在の6ヶ大隊、はいまや英国陸軍のみにウォーリアが就役して装備される予定です。ウォーリアの車体は、傾斜した蔽い板を持つアルミの全溶接構造です。エンジンは、PERKINS社製の2300回転で550馬力の出力のCV8 TCAV8型ジーゼル・エンジンで、PERKINS ENGINES社により英国でのライセンス生産される米国ALLISON社のX300-4B型トランス・ミッションに接続しています。ウォーリアの砲塔は、重直壁で口径30ミリのRARDEN砲及び外部の架台に装備される口径762ミリL94A1型Chain Gunを装備します。中東及びボスニヤ・ヘルツェゴビナにおける作戦のため、ウォーリアには追加の装備されました。

영국의 보병 전투차 개발은 1970년대 초반부터 GKN사에 의하여 시작되었고 MCV80이라 명명되었다. 1980년 6월 영국군의 APC재배치 계획에 따라 1966년 이후로 사용하던 FV432의 후속 차량으로 MCV80과 미국의 M2 브레들리가 경합을 벌이게 되었고 영국군의 재정적 이유와 자국의 산업 보호 차원에서 MCV80이 정식 채용되었다. 그리하여 1980년 3대의 MCV80 시제품이 만들어지고 1984년 11월 기동훈련에 시험적으로 투입되어 처음 그 모습이 일반에 공개되었다. MCV80은 1986년 한해동안 290여대가 생산되었으며 그중 170여대는 2인승의 RARDEN포탑을 장비한 차량이고 나머지 120여대는 지휘, 통신차량이나, 대전차 미사일 탑재차등의 특수 임무 차량으로 제작되었다. 워리어(MCV80)는 1987년 5월 영국군에 정식 인도 되었으며 그 다음의 2차, 3차의 생산량은 총 763대로 예정되어 영국군은 1053대의 워리어를 보유할 예정이었다. 그러나 최종적으로 생산 인도된 수량은 모두 8개의 기계화 보병 대대가 보유할 수 있는 789대였다. 워리어를 보유하고 있는 부대는 독일 주둔 영국군 주의 6개 대대와 영국 본토의 2개 대대이다. 워리어의 기본구조는 2인승의 RARDEN포탑을 탑재하고 조종수와 차장(포탑우측), 포수(포탑좌측)등 3명의 승무원과 후부 탑승실에 7명의 무장보병을 승차시킬 수 있으며, 주무장으로 30mm RARDEN기관포와 7.62mm L94A1체인건을 부무장으로 장비하고 있다. 워리어는 1991년의 걸프전 기간중 90여대가 투입되었으며 그 성능은 당초의 우려와는 달리 아주 성공적으로 평가되고 있다. 그리고 근래의 유고내전에서도 UN평화유지군의 차량으로 큰 활약을 보이고 있다.

<READ THIS BEFORE YOU BEGIN>

- Study the instructions before assembling. - Check the fit of each piece before cementing into place.
- Do not use too much cement to join parts. - Never use cement or paint near open flame.
- Open a window or make area well ventilated when cement or paint is in use.
- Tear up and throw away the empty plastic bags to avoid danger of suffocation for little children.

<ALLGEMEINE HINWEISE>

- Die Anordnung der Bauteile ist aus den Zeichnungen der Anleitung ersichtlich.
- Die Teile vor dem Verkleben ungeleimt zusammenhalten, um ihren paß zu prüfen.
- Klebstoff nicht zu dick auftragen. - Klebstoff und Farben niemals in der Nähe einer Flamme verwenden.
- Während der Bemalung mit Spritzpistole oder Pinsel für frische Luftzufuhr, z.B. Öffnen des Fensters, sorgen.
- Bausatz von kleinen Kindern fernhalten. Verhüten Sie, daß Kinder irgendwelche Bauteile in den Mund nehmen oder Plastiktüten über den Kopf ziehen.

■조립하기 전에

- 부품을 조립하기 전에 설명서를 잘 읽어본 후 조립한다.
- 부품을 조일 때는 접착제나 페인트를 가까이 하지 않는다.
- 조립하기 전에 부품을 잘라서 확인한 후 조립한다.
- 에나멜 페인트나 접착제를 사용할 때는 창문을 열어 환기를 시키고 화기를 끈다.

<LISEZ CE QUI SUIT AVANT DE COMMENCER LE MONTAGE>

- Étudier les schémas d'assemblage. - Contrôler que chaque pièce soit bien conforme avant de la coller à sa place.
- N'utilisez pas trop de colle pour réunir les pièces. - Ne faites jamais manipuler la colle ou peinture à proximité d'une flamme.
- Aérer soigneusement la pièce où vous peignez(ouvrez la fenêtre). - Après avoir sorti les pièces du sac en plastique, déchirer le sac afin d'éviter que les enfants ne le mettent sur la tête et ne s'étouffent.

<組み立てる前に>

- 組み立てる前に説明書をお読み下さい。 -部品をランナーから切りはずす時は模型用ニッパーとカッターを使用します。
- 接着剤を少なめに使うことがきれいに仕上げるコツです。 -組み立て後の部品やビニール袋は小さな子供の手の届かない安全な所に保管し、
- 接着剤や塗料を使用する時はときどき窓を開けて換気に気をつけましょう。 -接着する前に部品を合わせて確かめます。

-접착제를 사용할 곳과 사용하지 않는 곳에 주의하고 너무 많이 바르지 않도록 한다.

-사용 후 남은 부품은 어린 아이들의 손에 닿지 않도록 잘 처리한다.

 점착한다 Cement parts Coller Kleben Pegar Incollare Colar Kleven	 점착하지 않는다. Do not cement Ne pas coller Nicht kleben No pegar Non incollare Nao colar Niet kleven	 3 수행할 것임한다. Repeat operation Répéter l'opération Vorgang wiederholen Repetir la operación Repetire Repetir a operação Herhalen	 전사지를 붙인다. Decals Dicalcomanies Abziehbild	 9 무게추를 넣는다. Add weight Lester Gewicht	 수입이나 출몰 적외선이다. Use filler Mastiquer Schließen
 잘라낸다. Cut away Couper Schneiden Cortar Tagliare Cortar Snijden	 선택한다. Optional parts Choix Auswahlmöglichkeit Eleccion Scelta Opcao Kreuze	 반대측도 포함한다. Repeat for opposite side Répétition de la page Wiederholung für gegenüberliegende Seite	 구멍을 뚫어낸다. Make hole Faire un trou Öffnen	 주의한다. Be careful Faire attention Hier Vorsicht	 색도 및 전사지 붙이기 번호 Painting scheme number Numeros de la lista de pinturas Lackierschemanummer

1 * () is opposite number.
()는 반대측 번호입니다.

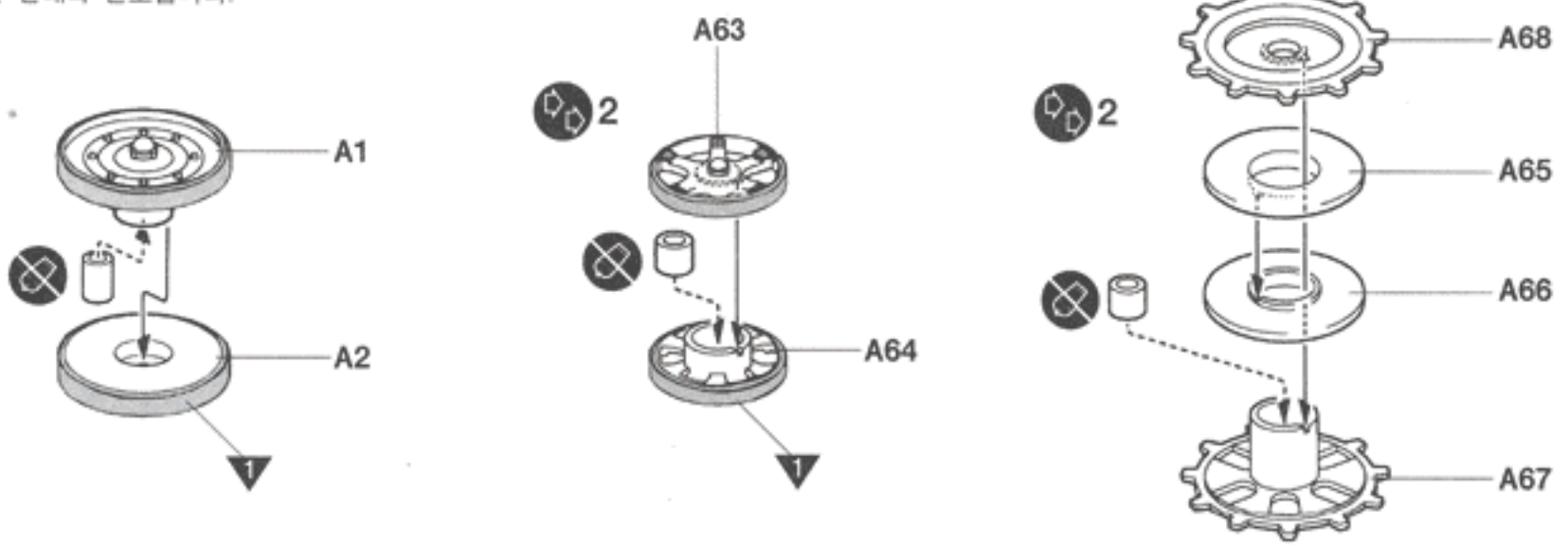

2

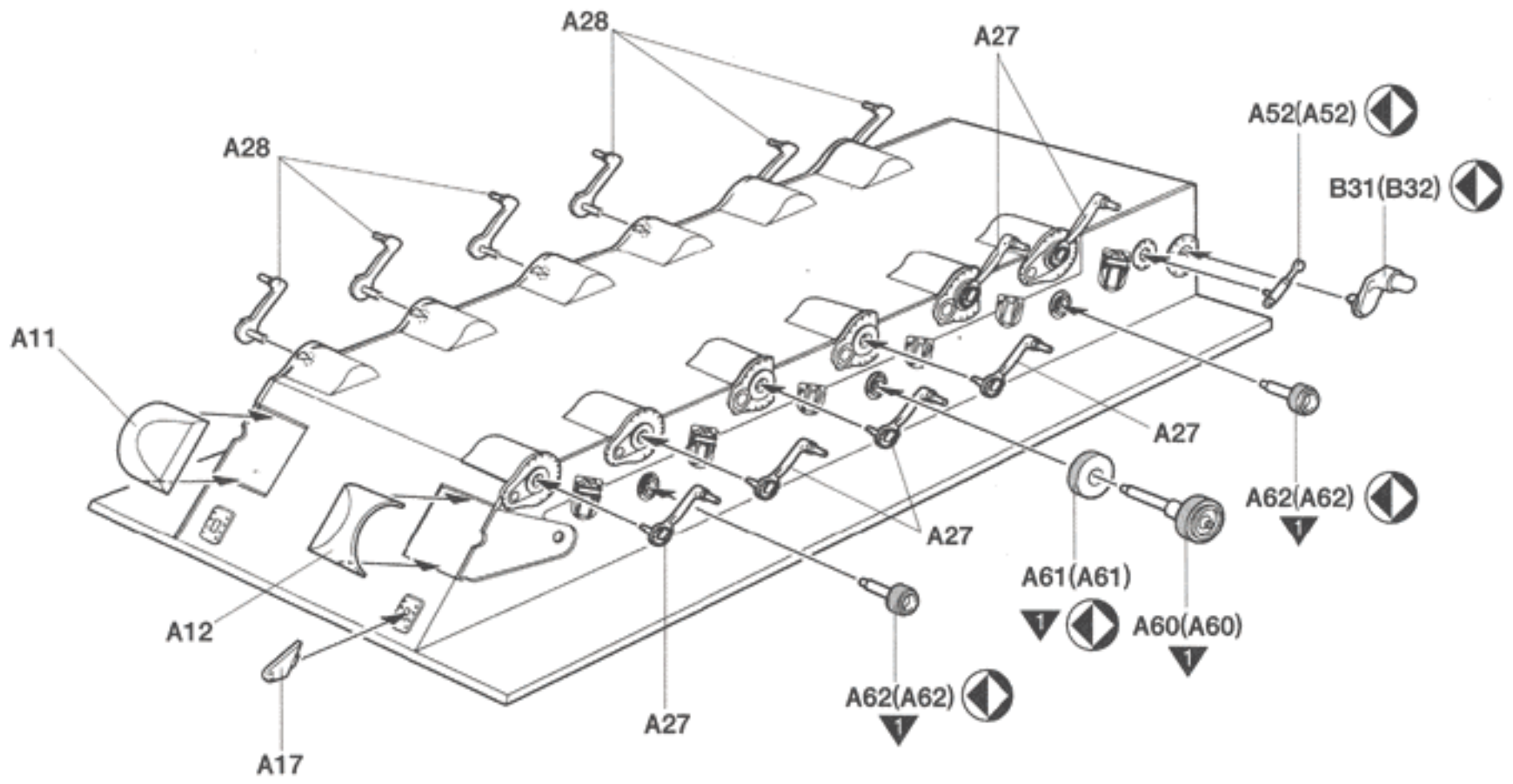

3

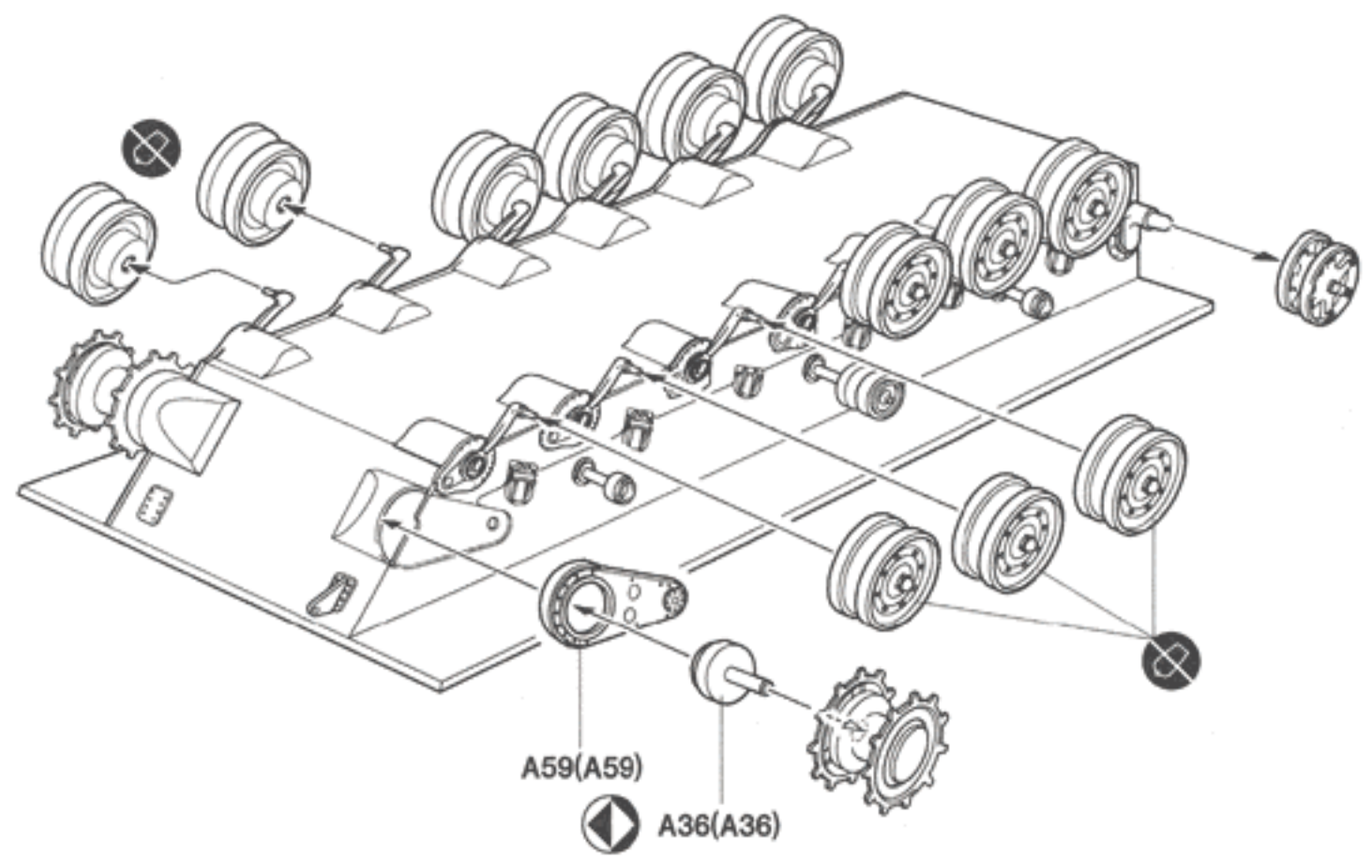

4

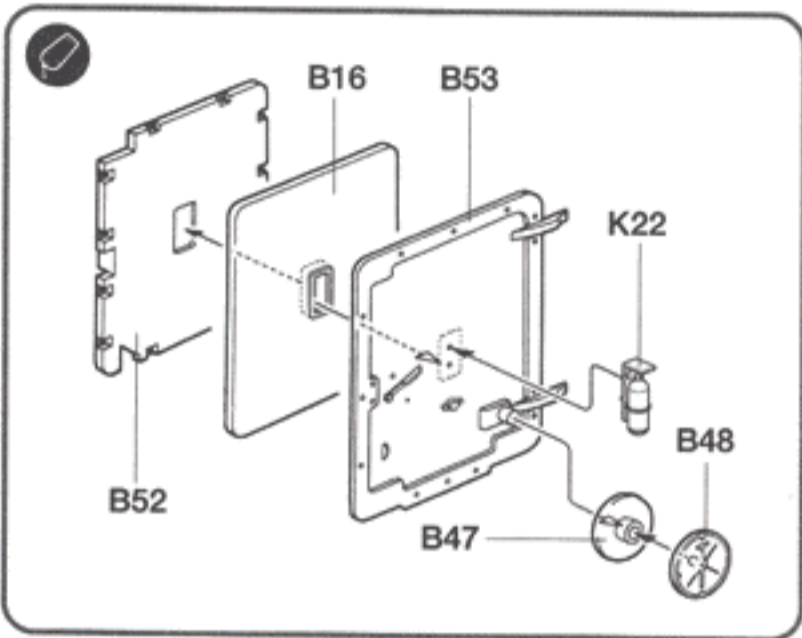
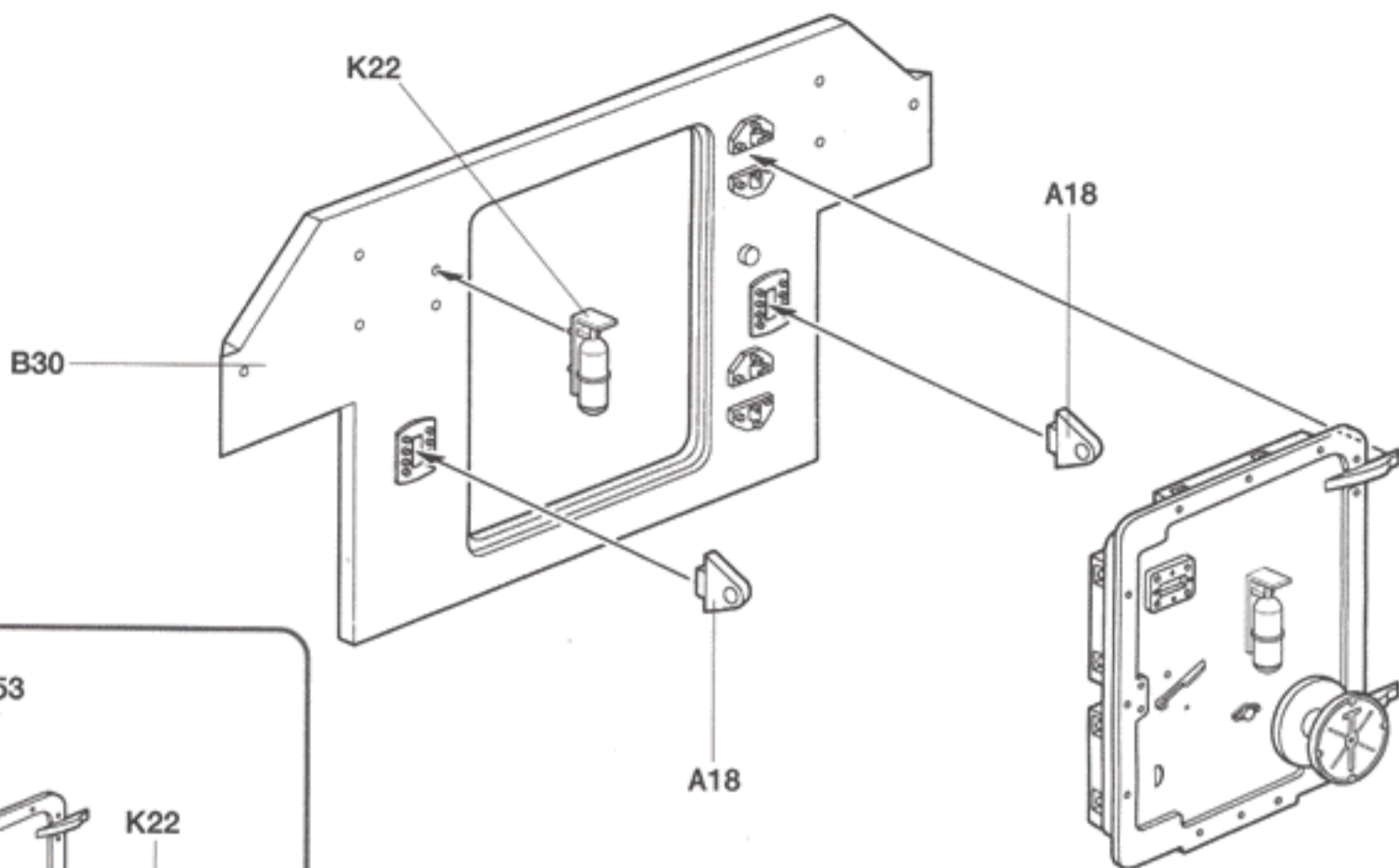

5

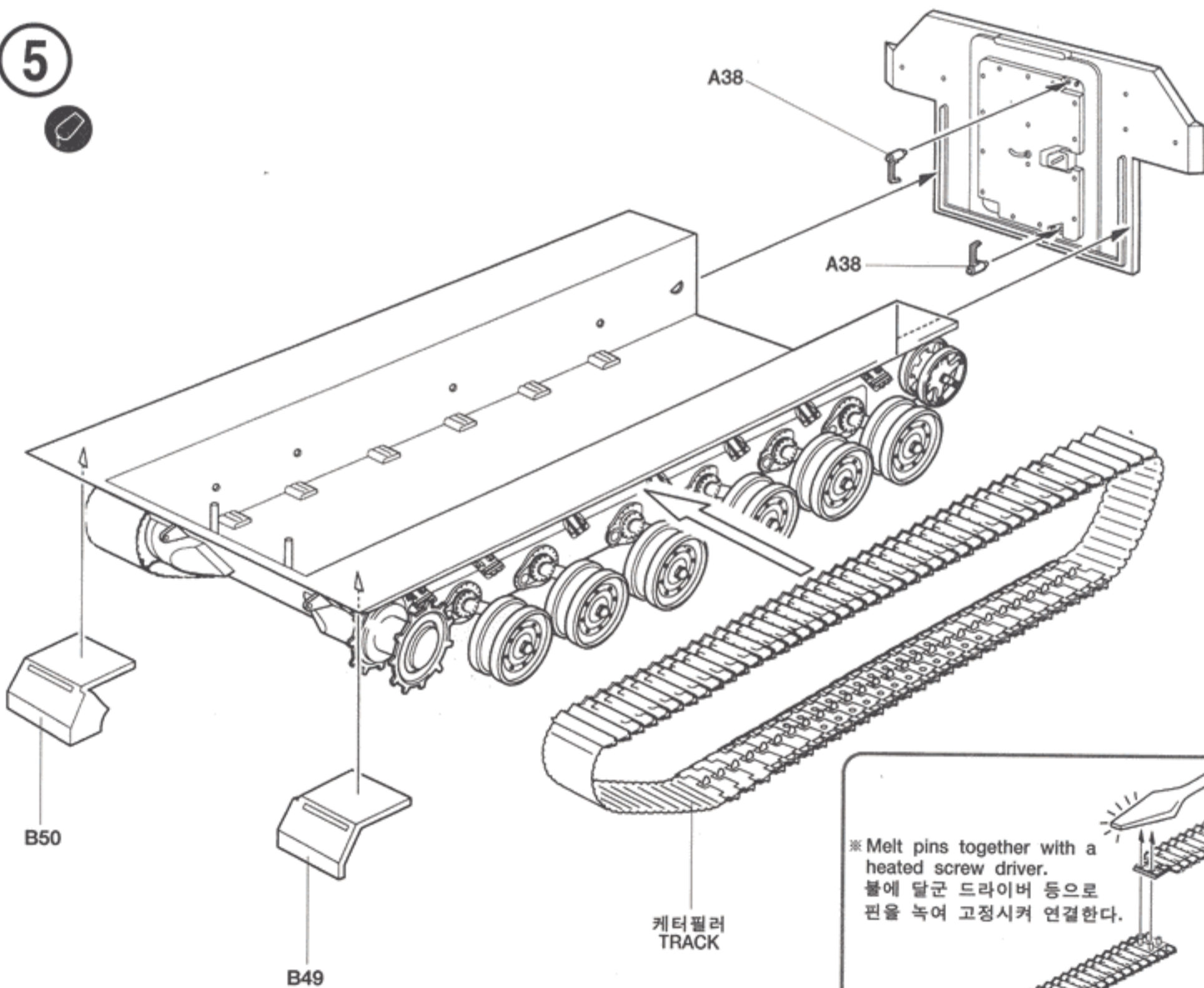

※ Melt pins together with a heated screw driver.
 불에 달군 드라이버 등으로 핀을 녹여 고정시켜 연결한다.

6

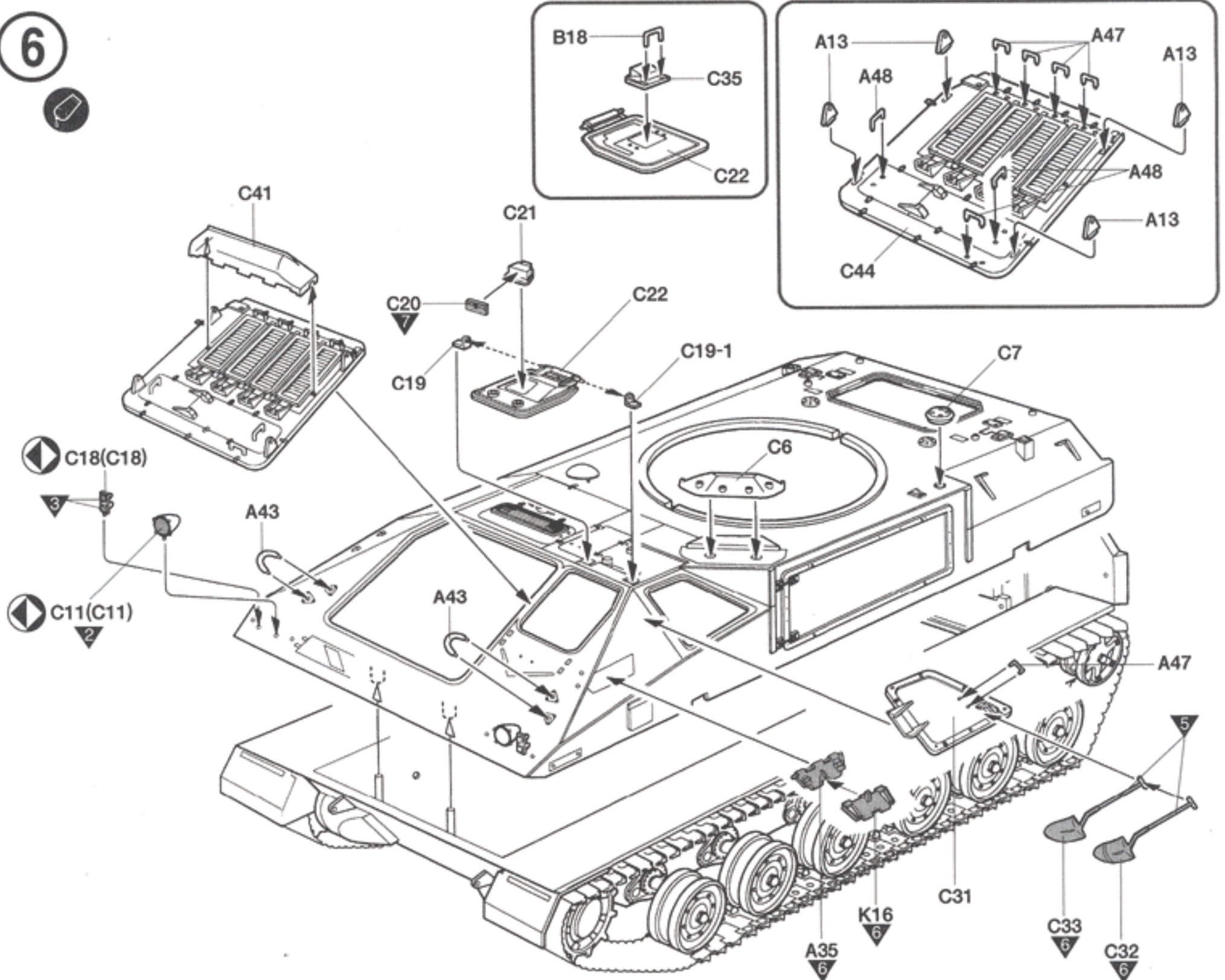

7

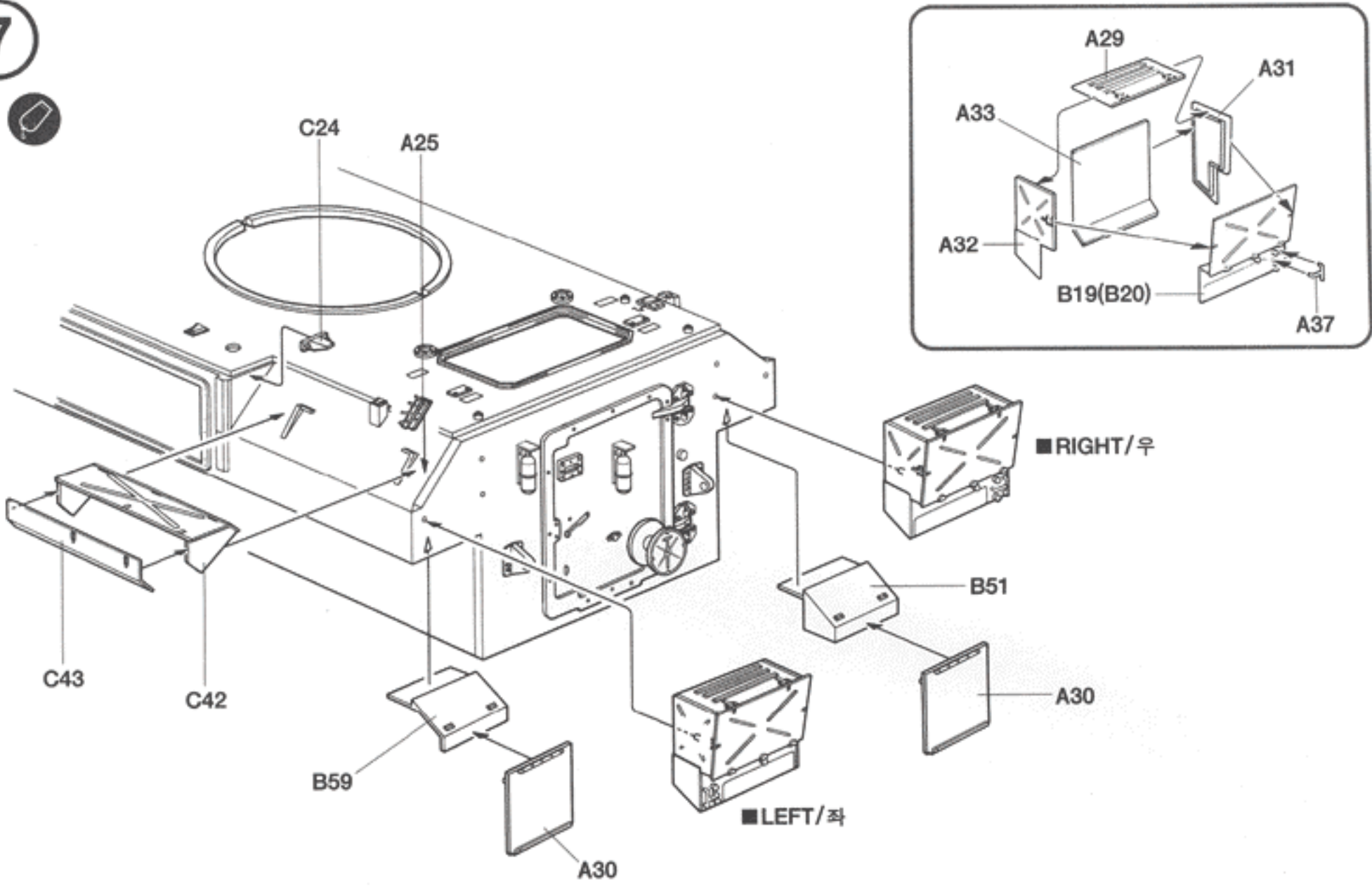

8



C10(C10)

A23

C12(C13)

C39

A47

A48

K21

C16

C15

C17(C17)

B22

A25

C8

B23

9



A40

A39

A39

C9

C9

C37

B21

C36

B24

10

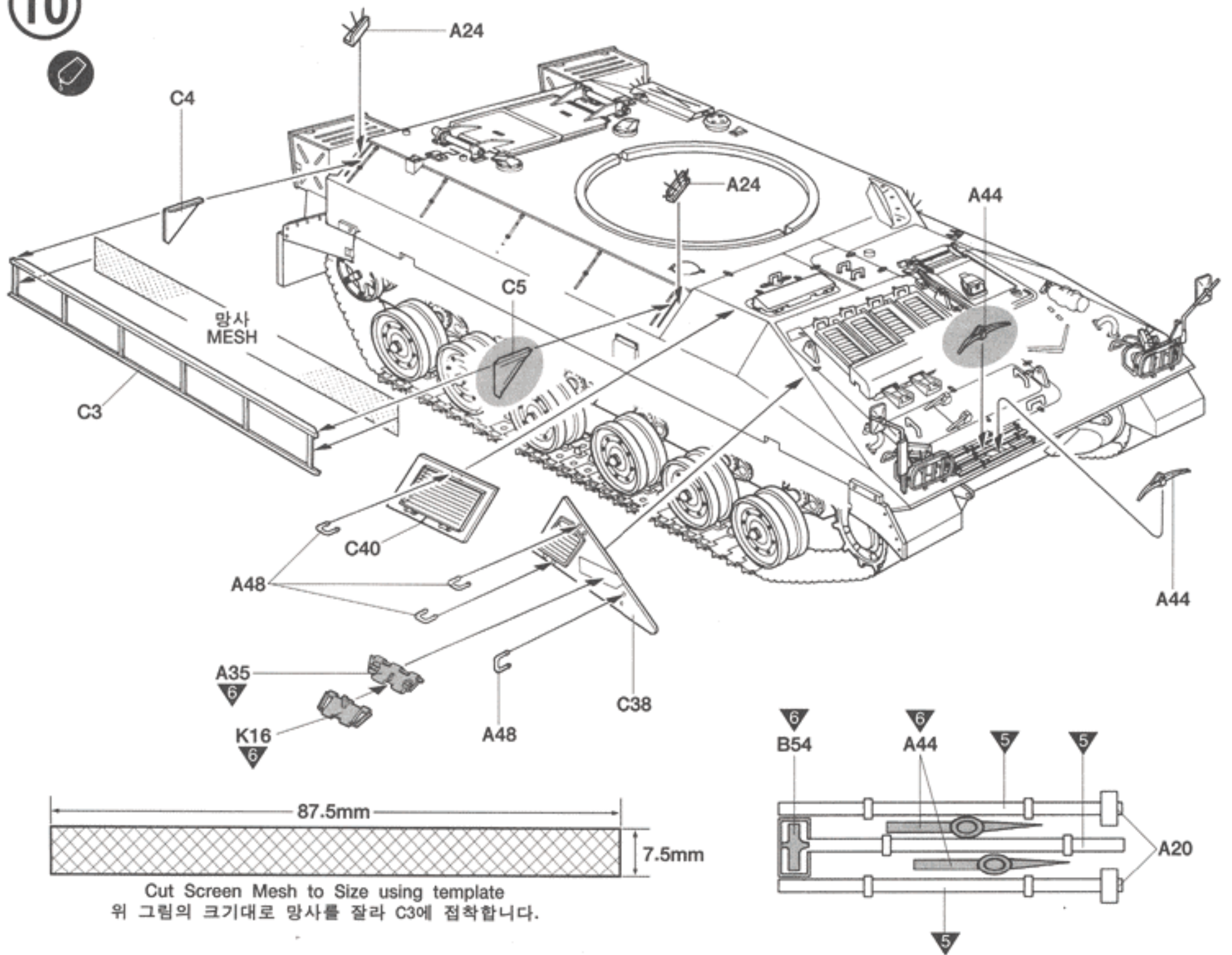

Cut Screen Mesh to Size using template
 위 그림의 크기대로 망사를 잘라 C3에 정착합니다.

11

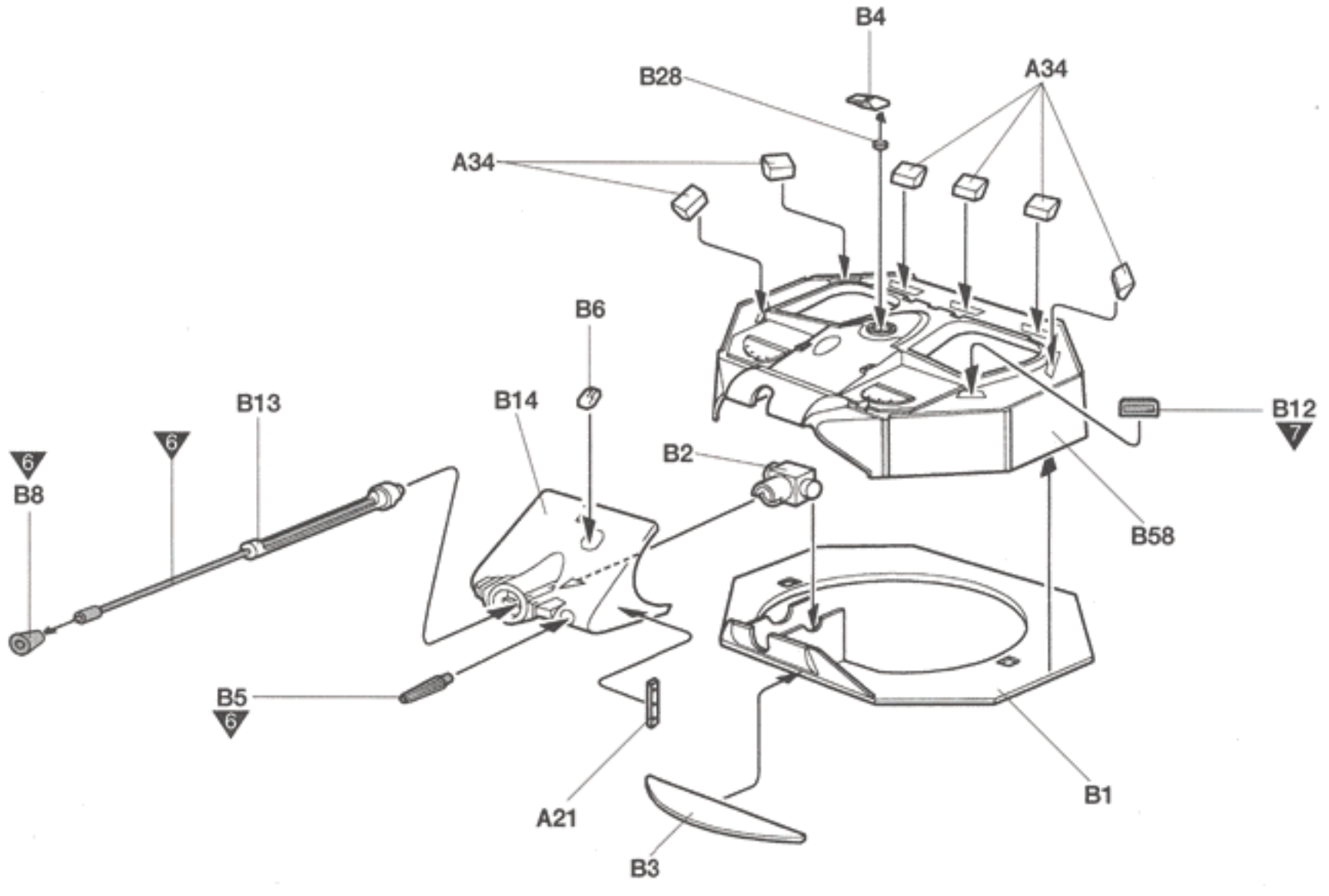

12

LEFT/좌

RIGHT/우

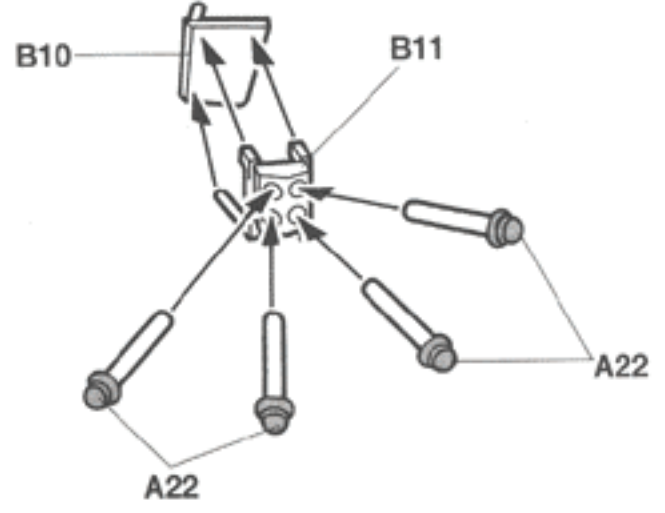
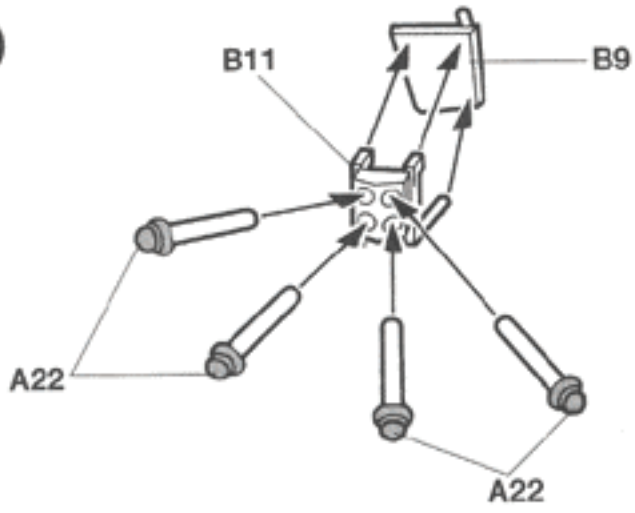

13

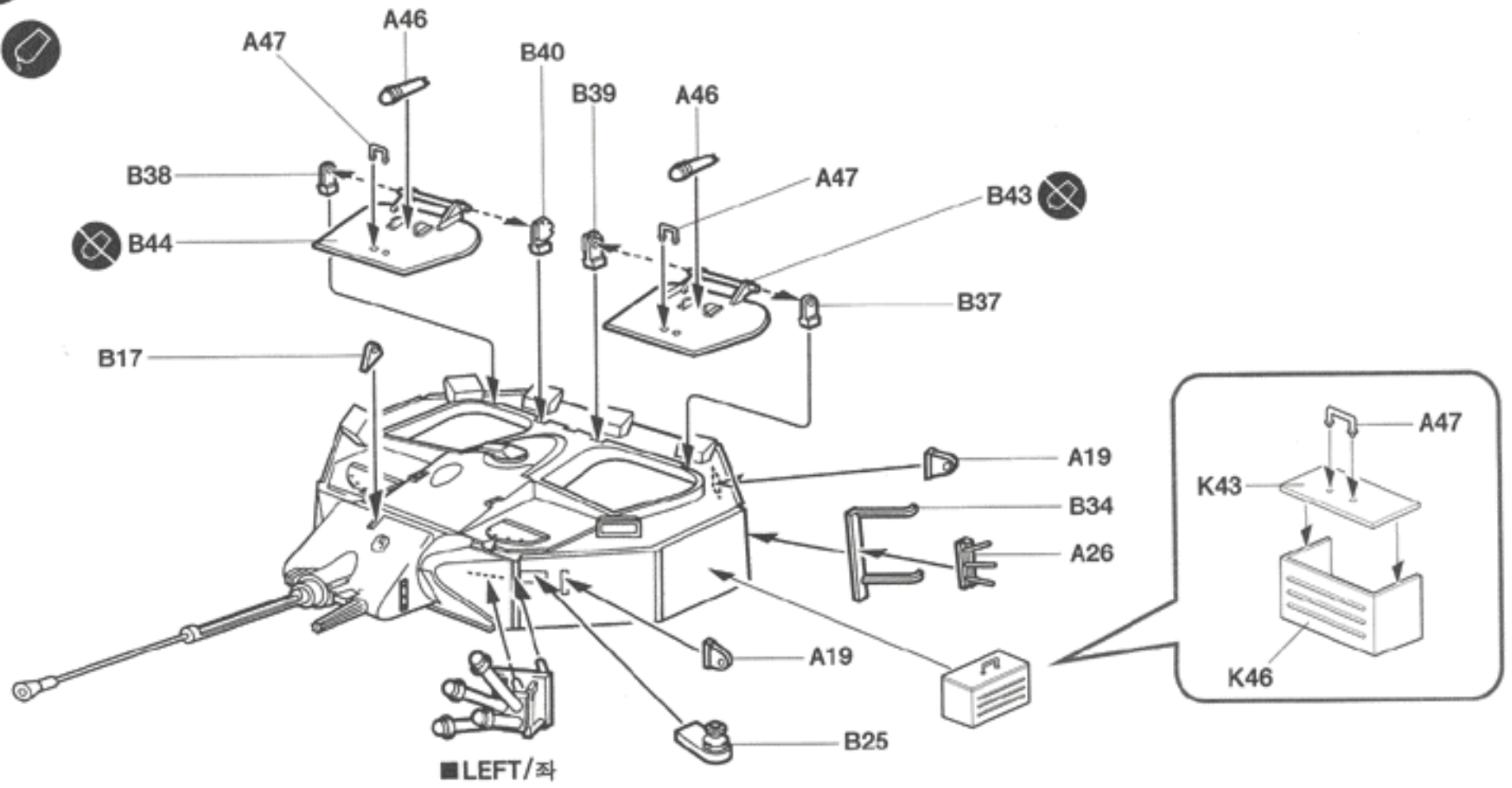

LEFT/좌

14

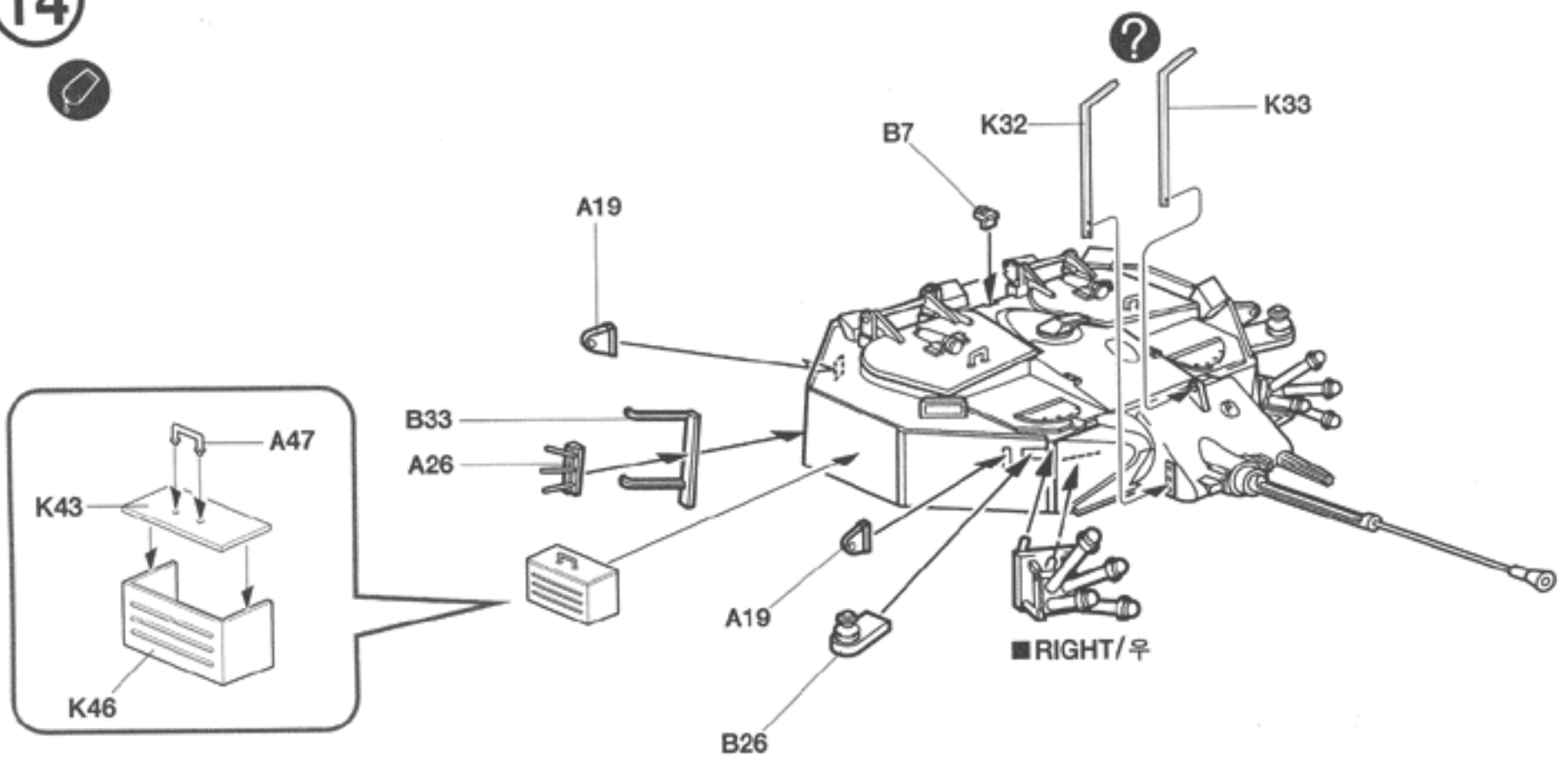

RIGHT/우

15



Cut Screen Mesh to Size using template
 위 그림의 크기대로 망사를 잘라 접착합니다.

2

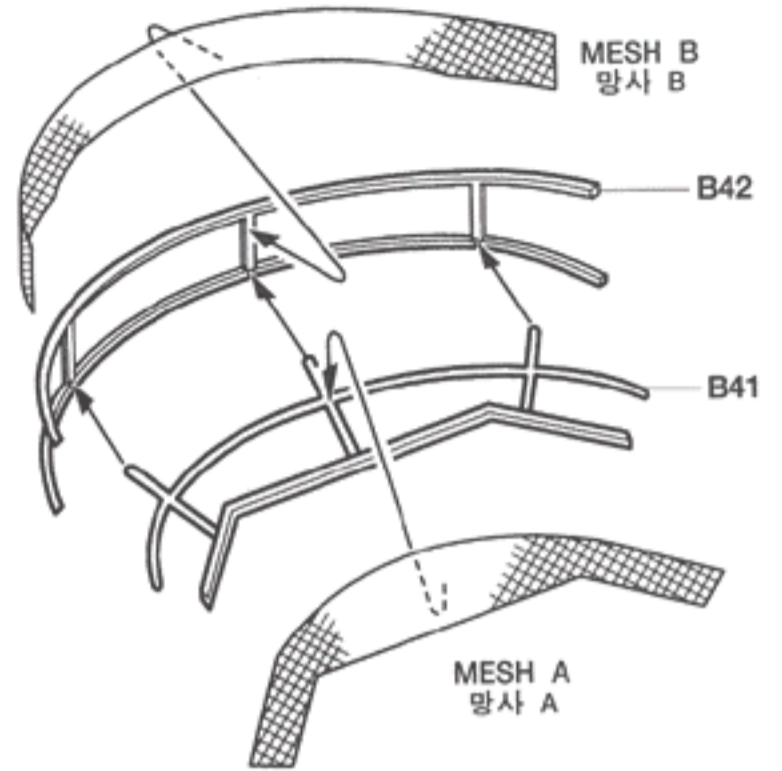
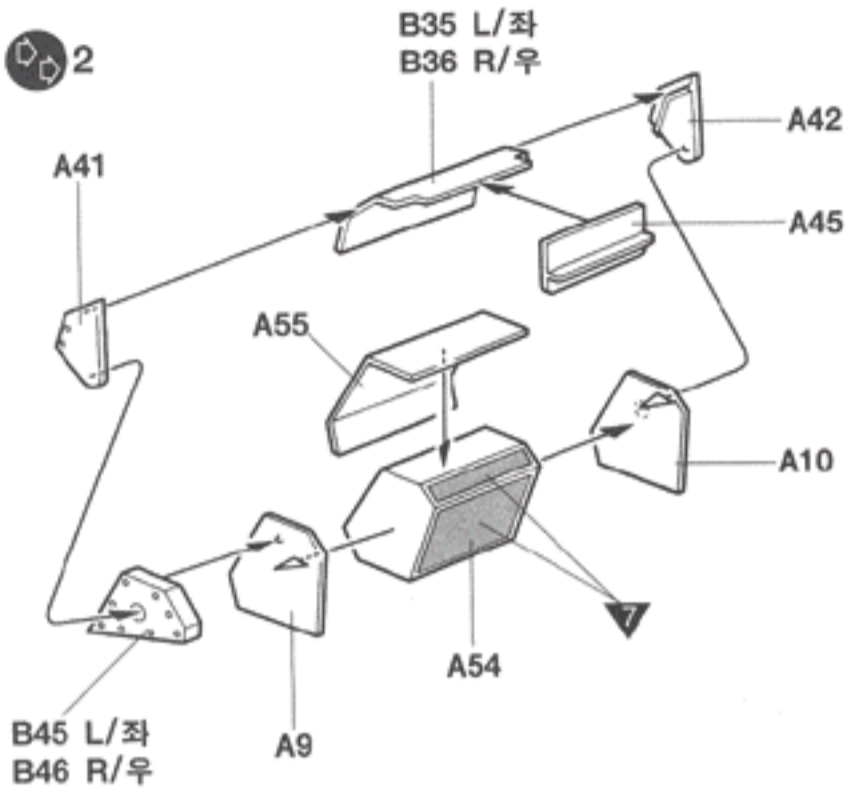

16

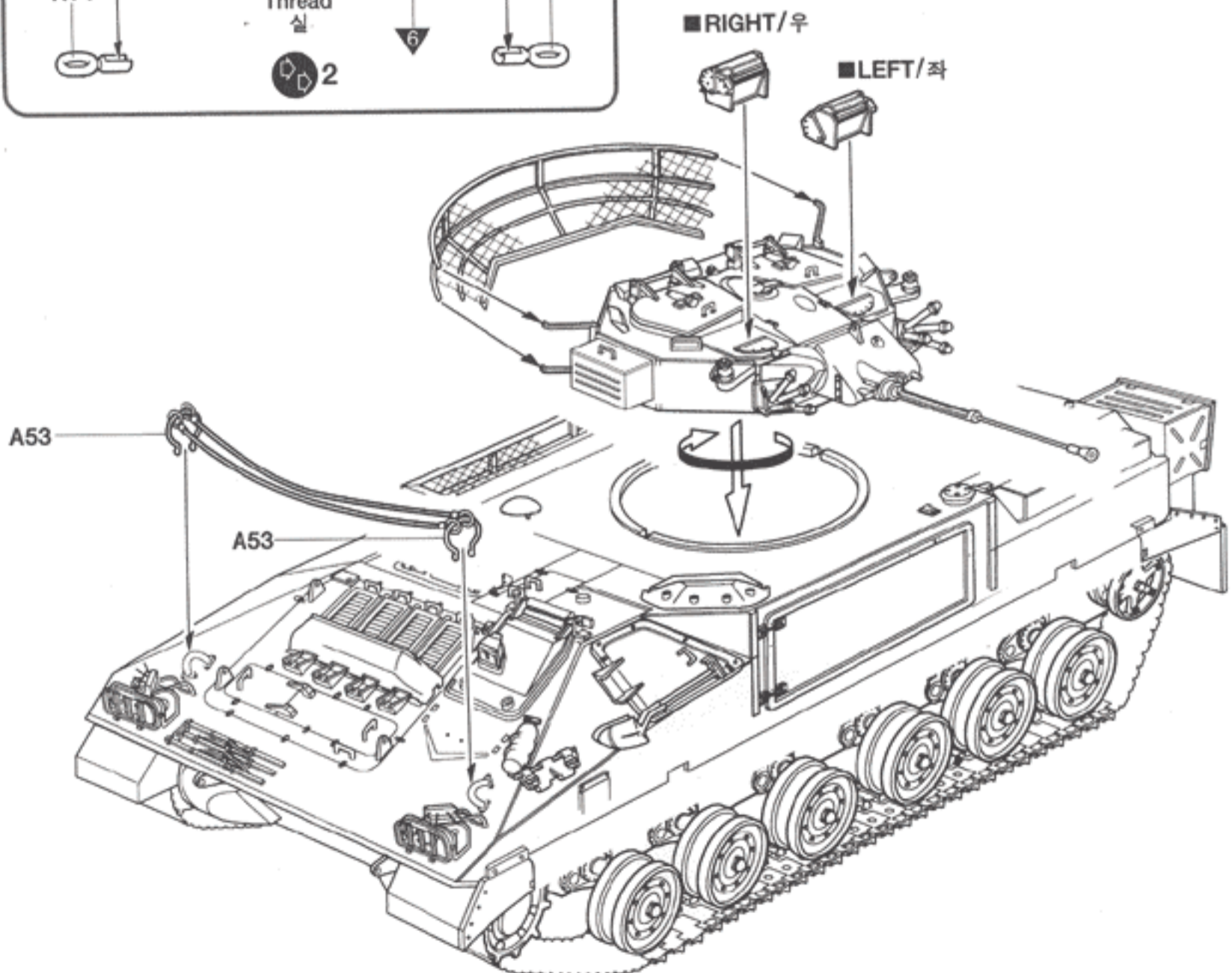
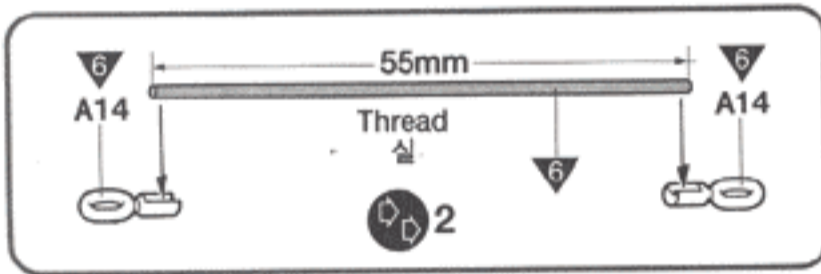

17

RIGHT/우

LEFT/좌

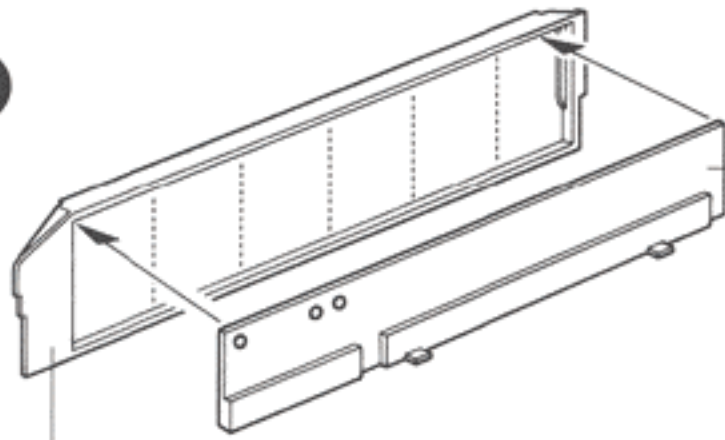

C26

C2

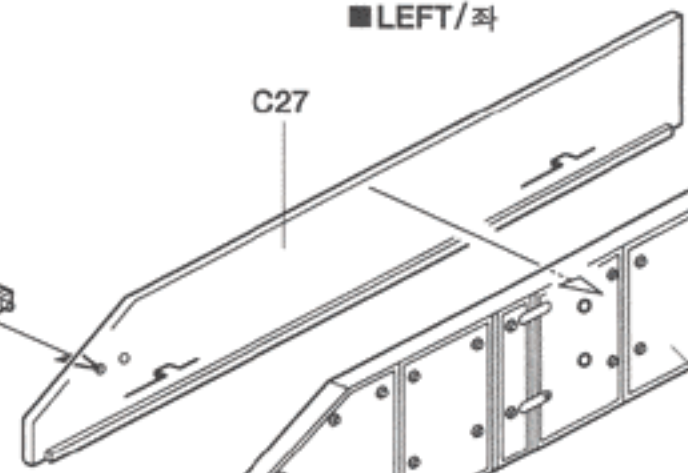

C27

C1

C34

K7

K11

K17

K20

K10

K8

K18

K9

FRONT/앞

18

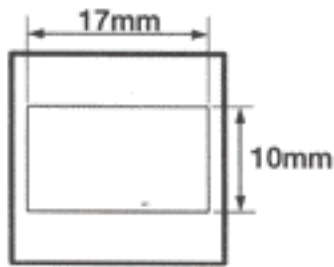

P.V.C

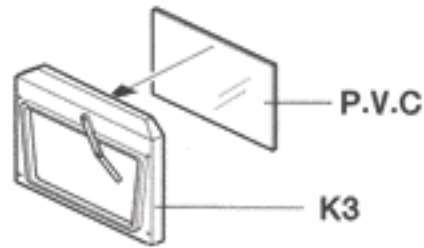

P.V.C

K3

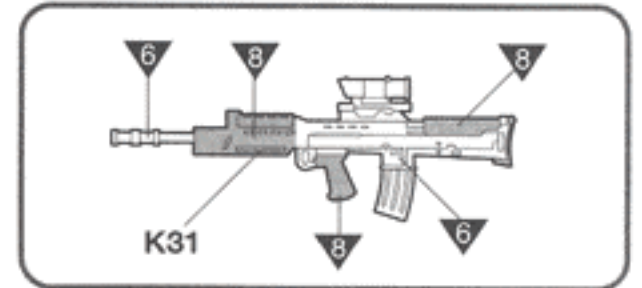

K31

RIGHT/우

K3 ?

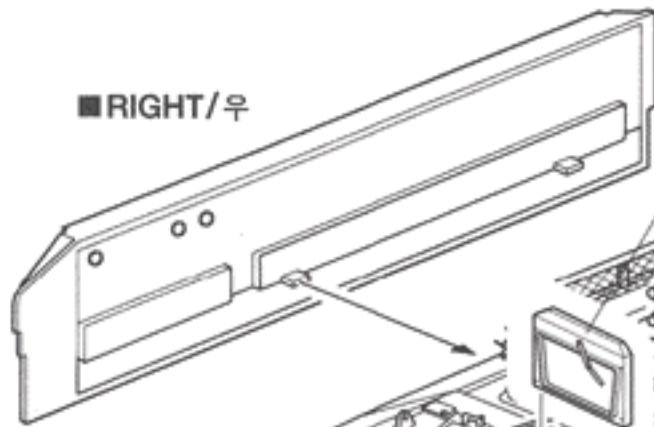

LEFT/좌

41mm

13mm

FRONT/앞

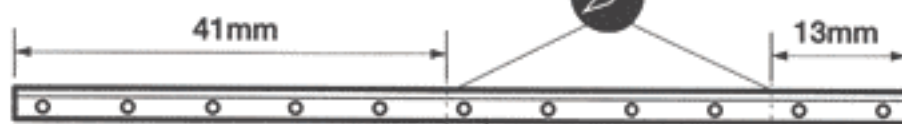

C25

※ Make holes B25, B26 if attached Antenna.
안테나를 접착할 경우에는 B25, B26에 구멍을 뚫어줍니다.



B25, B26

ACCESSORY PART 액세서리부품

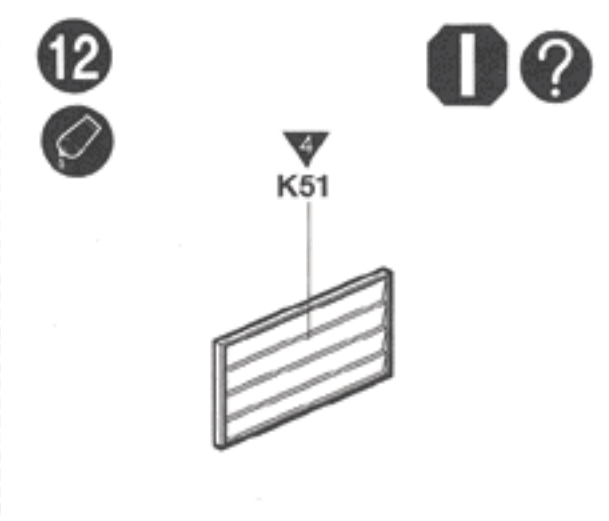
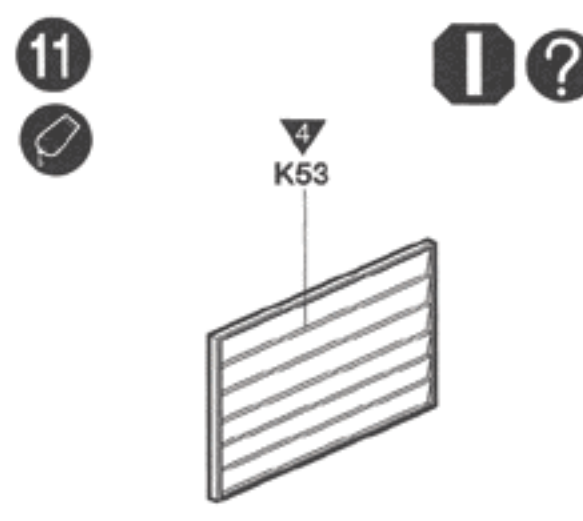
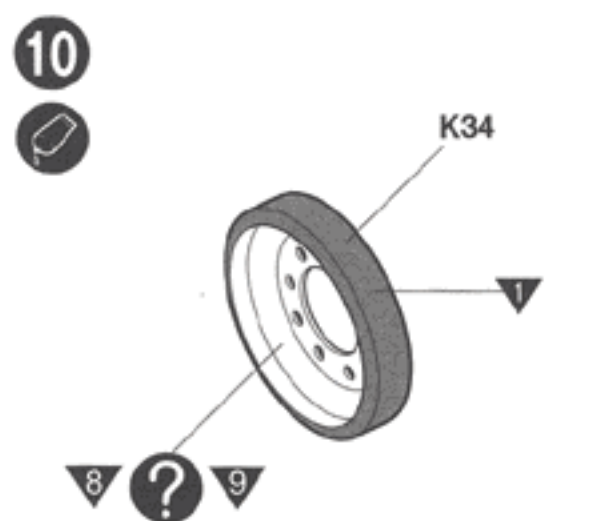
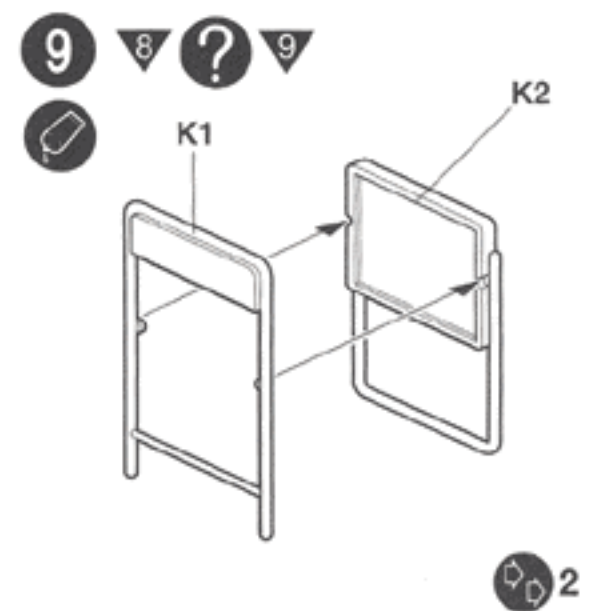
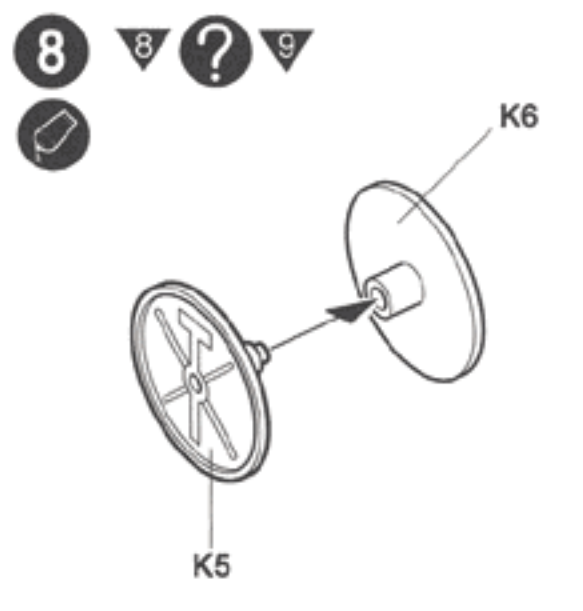
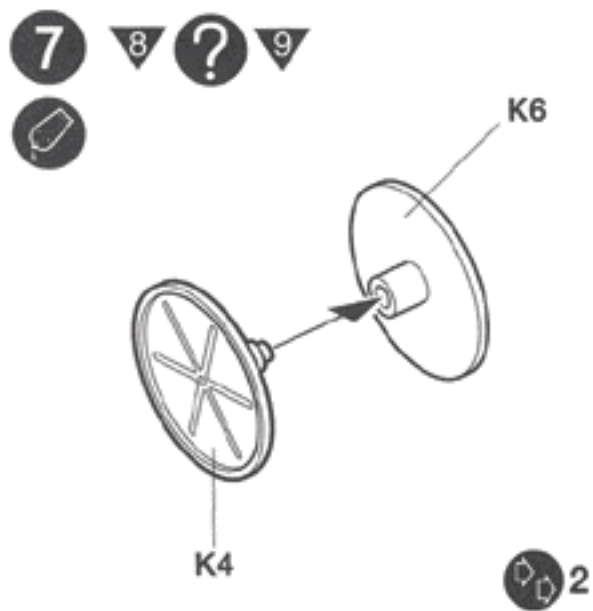
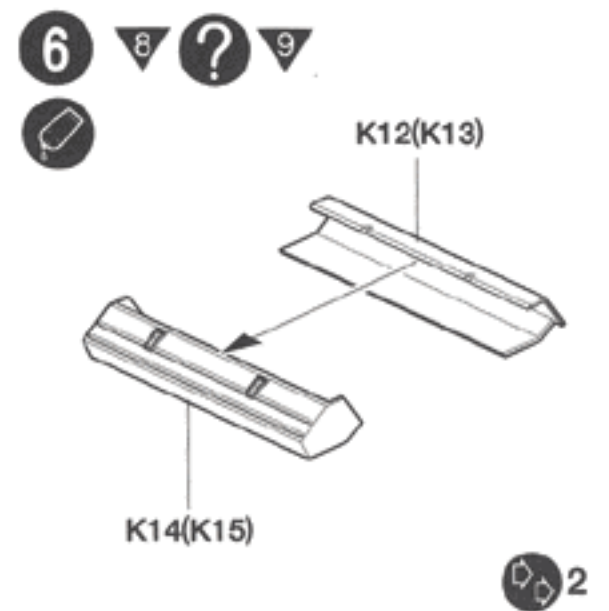
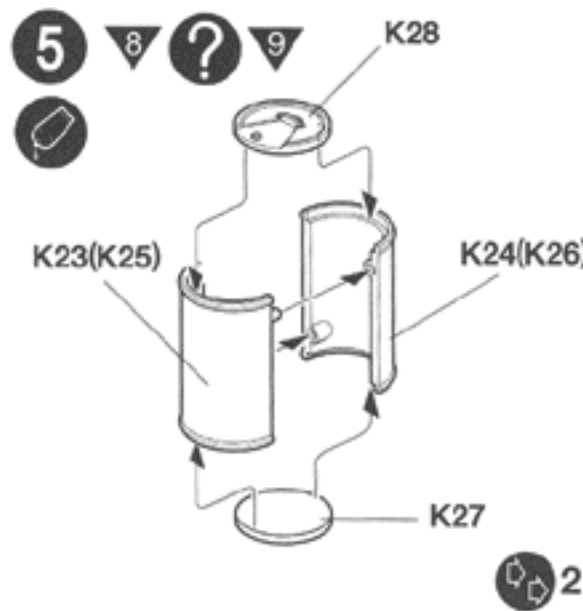
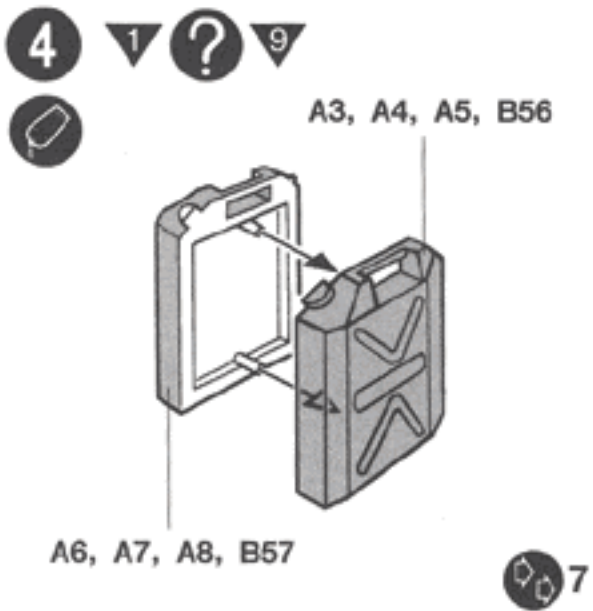
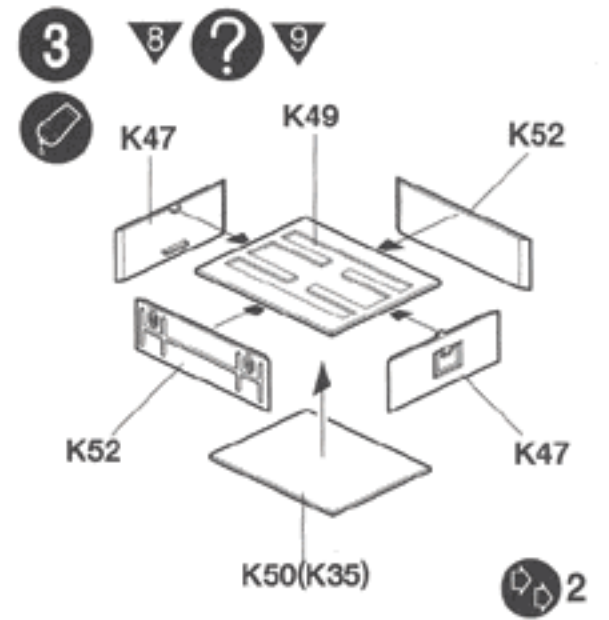
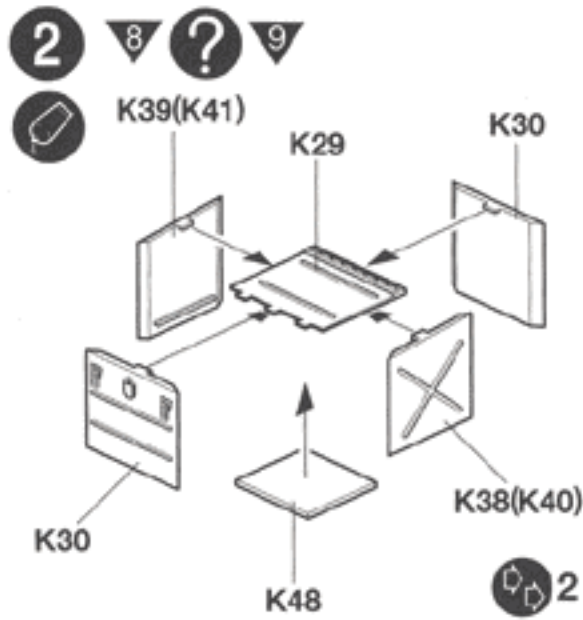
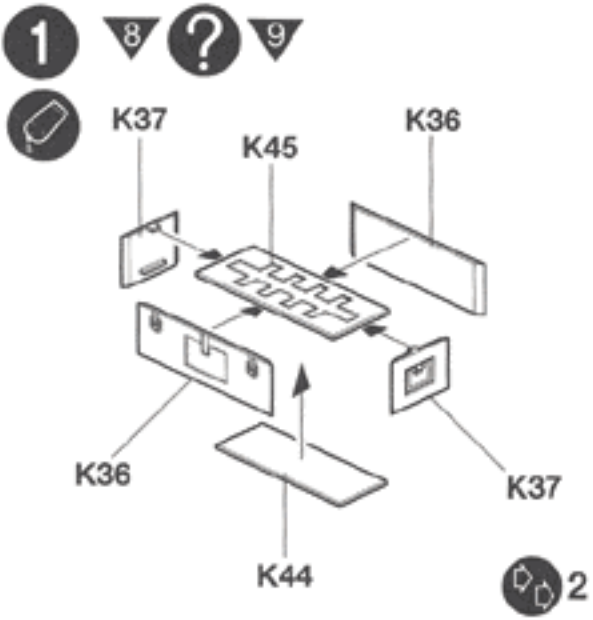

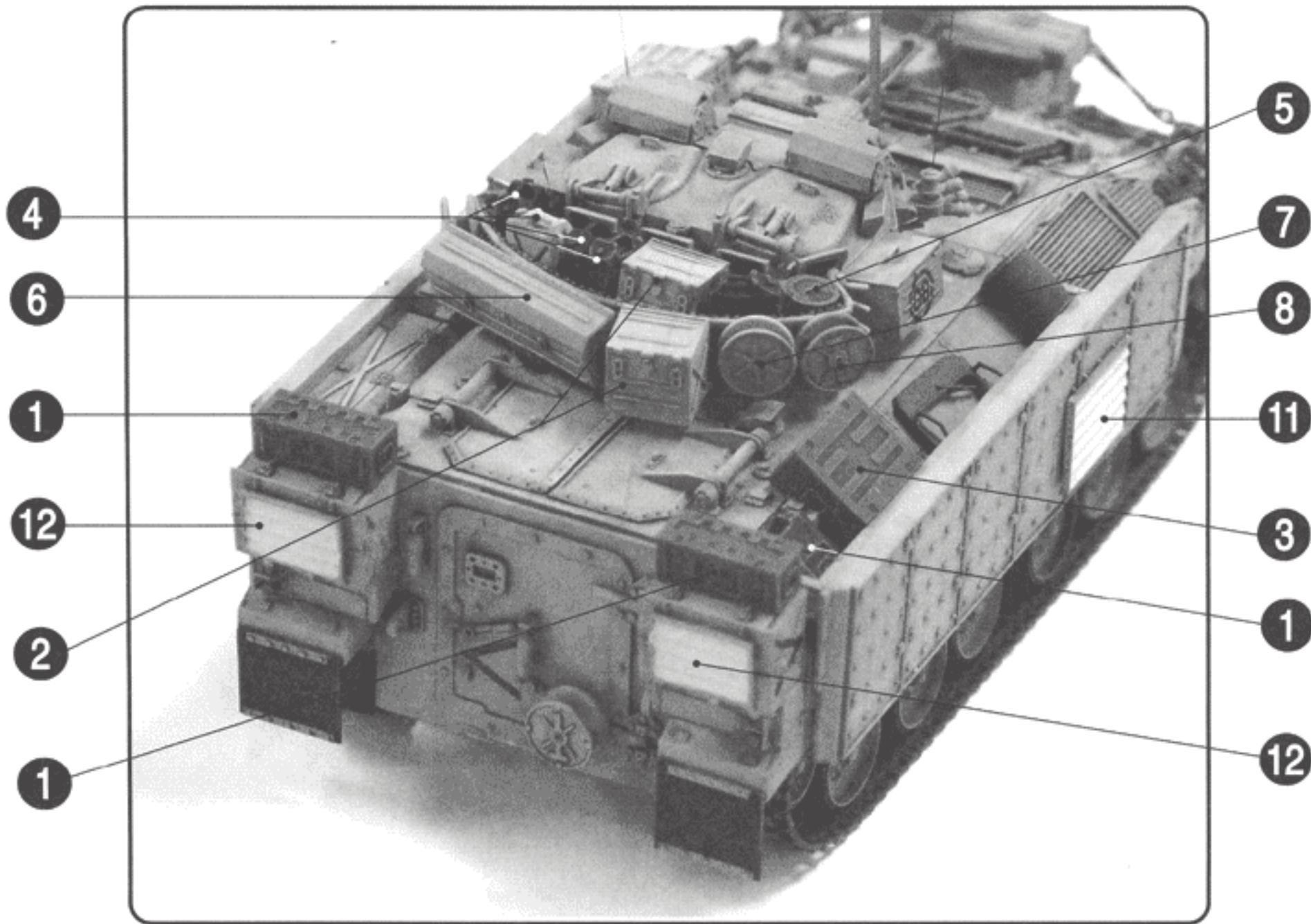
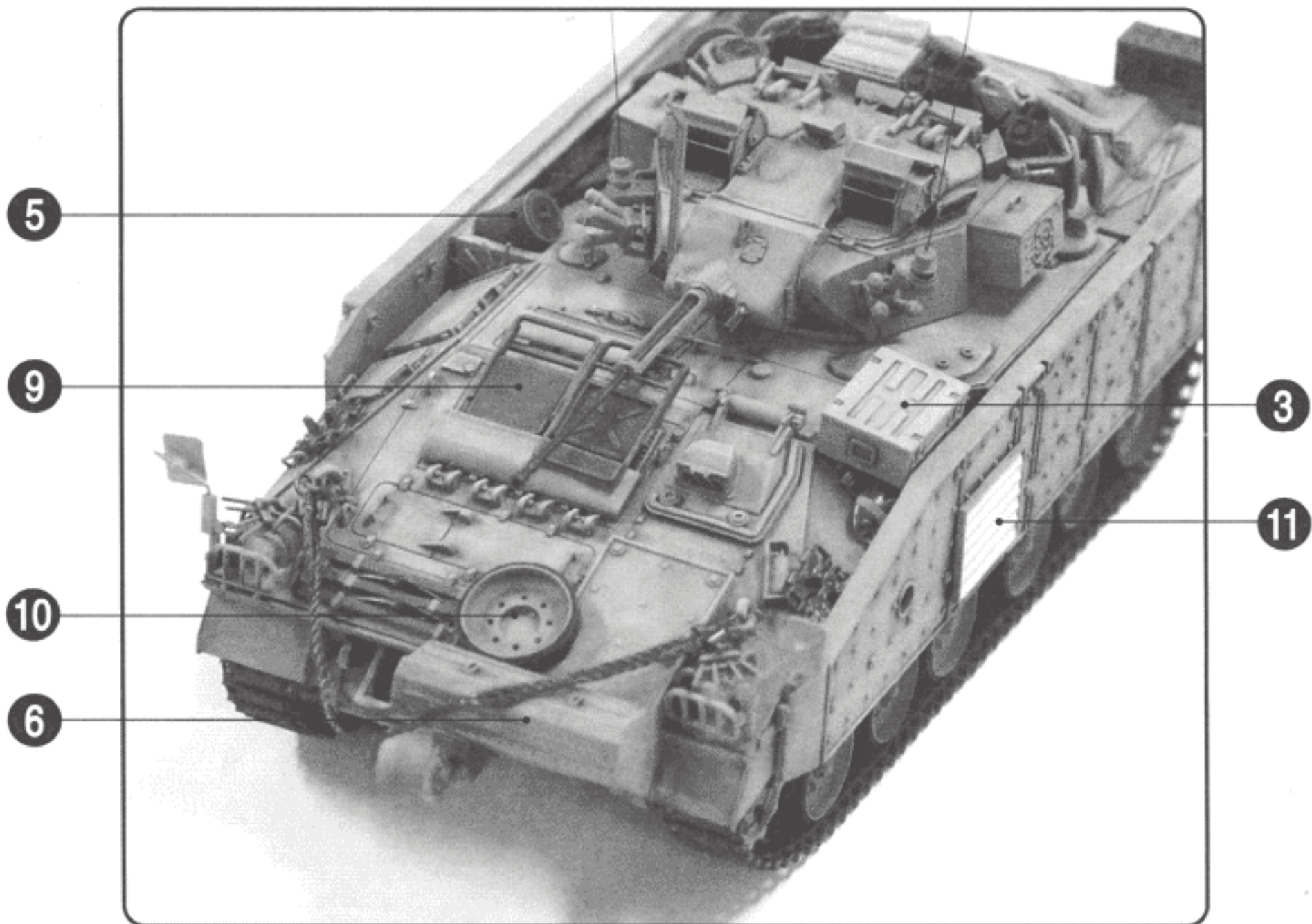

A × 2

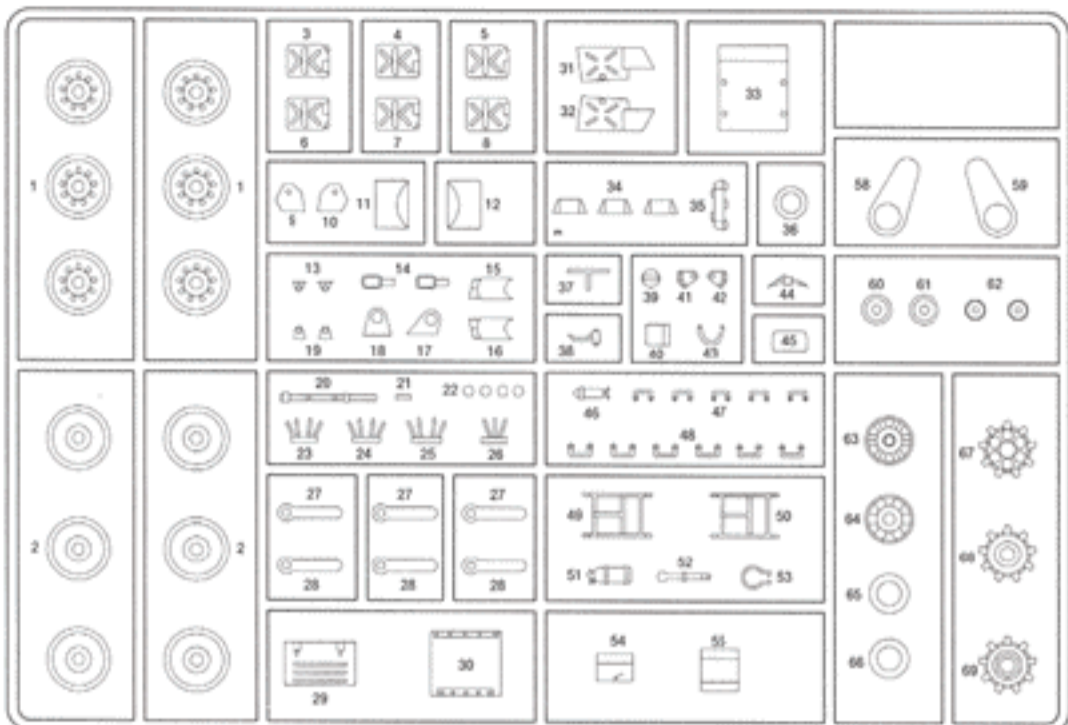

B

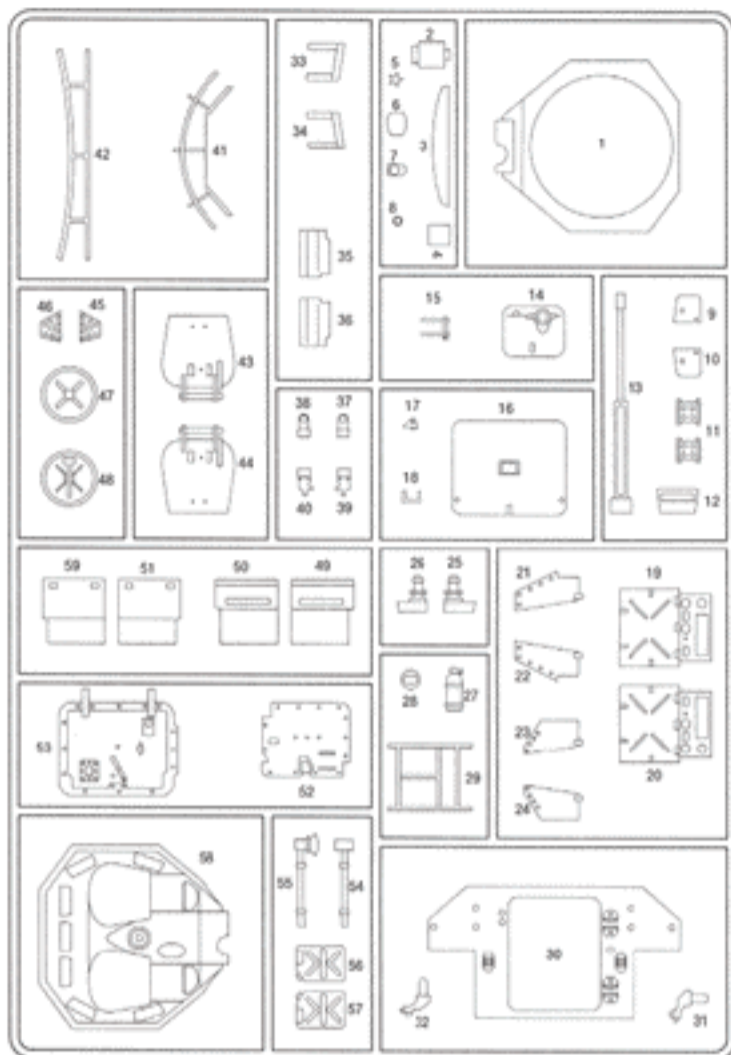

C

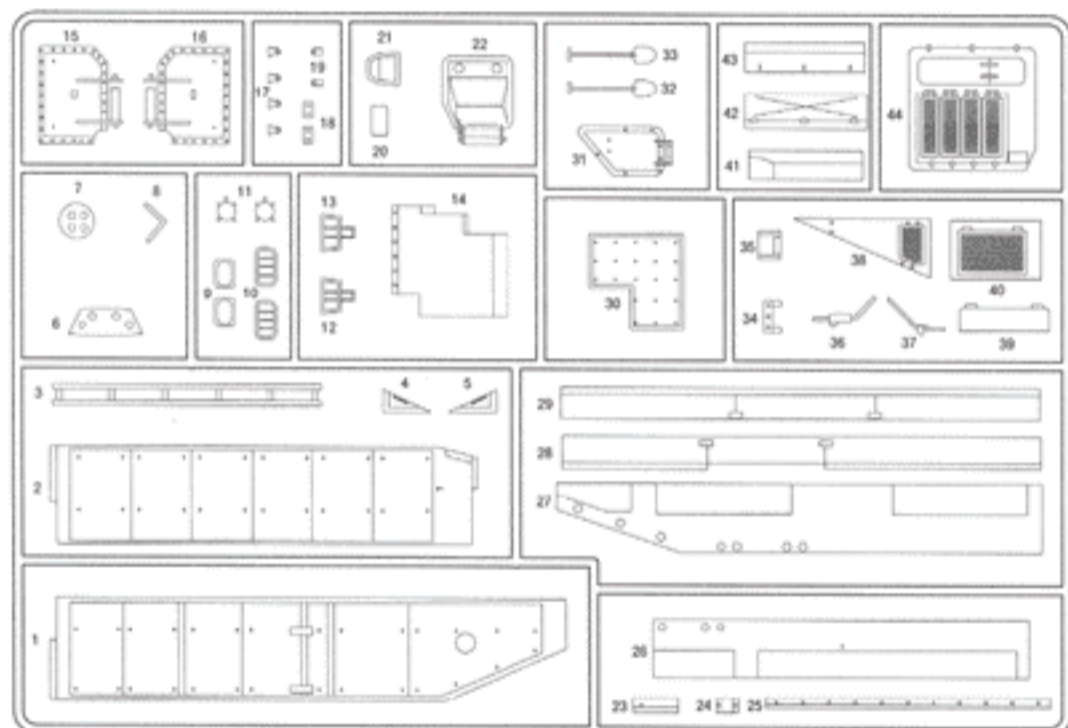

K

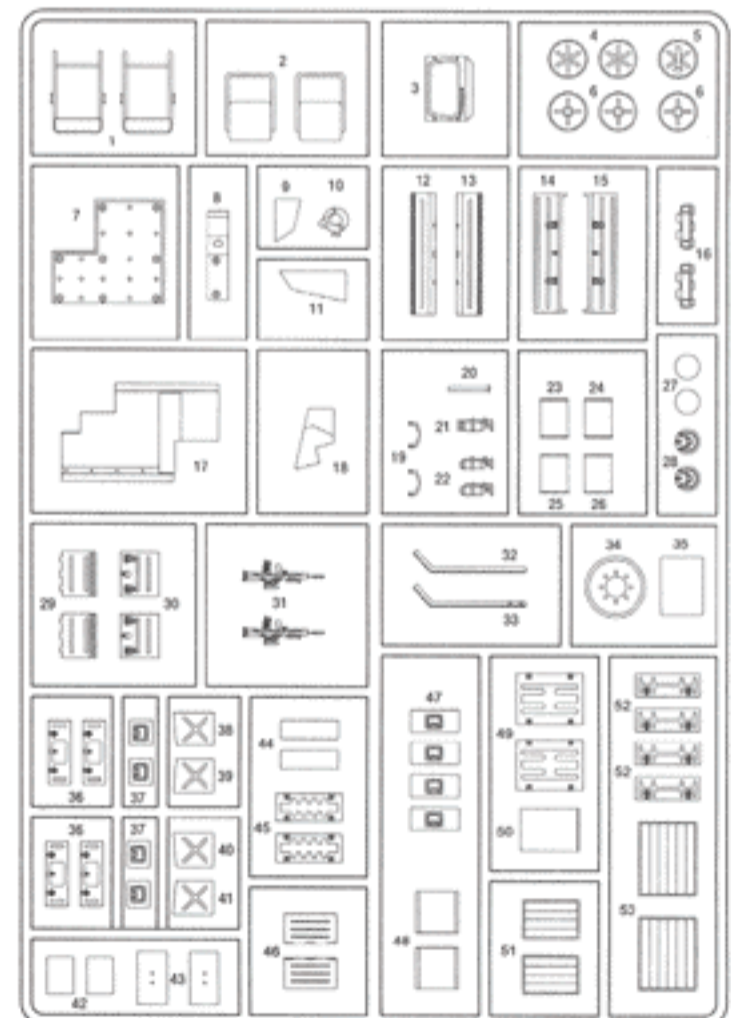

1 FALT BLACK	MATTSCHWARZ	NOIR MAT	つや消しブラック	무광 검정색
2 SILVER	SILBER	ARGENT	실버	은색
3 RED	ROT	ROUGE	레드	유광 빨강색
4 WHITE	WEISS	BLANC	호크이트	유광 흰색
5 LIGHT BROWN	HELLBRAUN	BRUN CLAIR	라이트 브라운	라이트 브라운
6 GUN METAL	METALL-GRAU	GRIS ACIER	간메탈	건예탈
7 CLEAR BLUE	BLAU, REIN	BLEU CLAIR	클리어 블루	클리어 블루
8 DARK GREEN	DUNKELGRÜN	VERT FONCÉ	다크그린	다크그린
9 DESERT YELLOW	SANDGELB	JAUNE DÉSSERT	데저트イエロー	데저트 옐로우

Unused parts 불필요 부품

A11×1, A12×1, A15×2, A16×2, A17×1,
A49×2, A50×2, A51×2, A69×2
B15, B27, B29, B55
C23

- 차체상부
- 차체하부
- 포리부품
- 실
- P.V.C 윈도우
- 캐터필러
- 망사

- 직매점 겸 A/S센터
- A / S 센터
- 총판점 겸 A/S센터

- 유통사업부
- 홈페이지
- ☎ 고객상담문의

삼선교: 742-9293, 방배동: 525-9031, 양재동: 575-9997, 용산: 796-1214, 아셈해비센터: 6002-6293
본사: 908-7000(교한147), 통대문: 745-9293
캐릭터렌드: 907-0940, 양천아카데미: 2691-7108, 강남아카데미: 485-6884, 강북아카데미: 762-0980,
AB해비: (031)458-5591, 서면아카데미: (051)816-9773, 대구아카데미: (053)744-9293

아카데미피엔디: 586-9293
http://www.academyhobby.com
080-969-7000



ACADEMY PLASTIC MODEL CO., LTD.
273-64, Suyu-dong, Kangbuk-gu, Seoul, Korea
TEL: 82-2-908-7000 FAX: 82-2-997-3003

Painting & Decal placement 색칠 및 전사지 붙이기

I



British Army, Iraq 2003.

영국육군, 2003년 이라크.

9

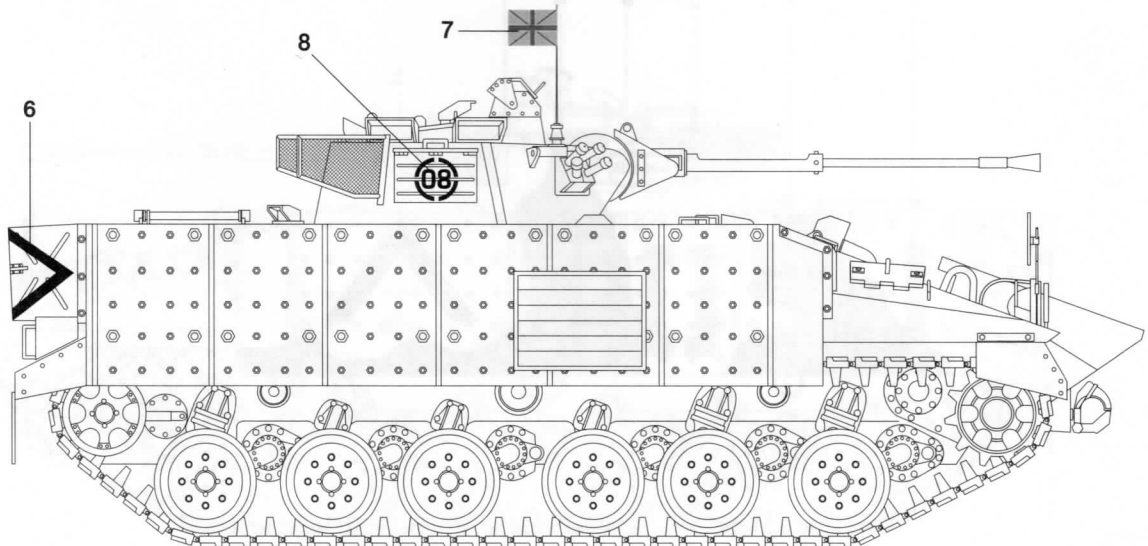
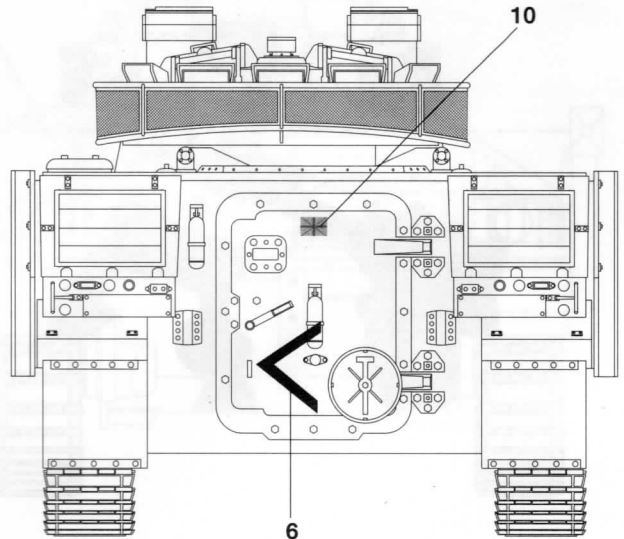
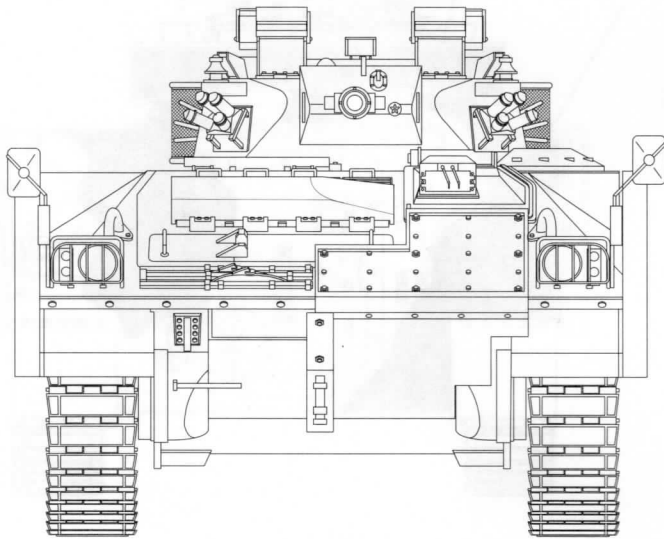
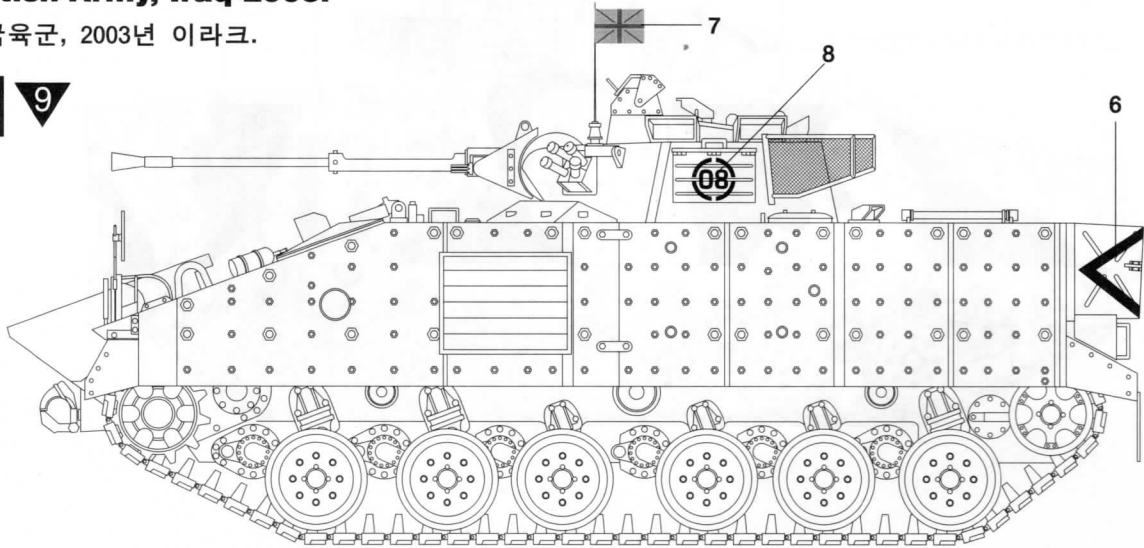

2 British Army, Bosnia, 1995.

영국육군, 1995년 보스니아.

