

# U.S. MULTIPLE GUN MOTOR CARRIAGE M16



## 1/35 MILITARY MINIATURE SERIES



Half-track vehicles were developed for the US Army from the early 30s when the US Ordnance Department studied the successful Citroen-Kegresse half-tracks from France. Various firms in the USA developed half-track designs on behalf of the Ordnance Department, the Gunningham motor company producing the first, designated T1, in 1932. By 1940 development work led to the Half-track T14 in which the layout and appearance of all subsequent W.W.II period American half tracks was finalised. Later in 1940 with the war already gripping Europe, the United States commenced a big re-armament programme, and in September 1940 the existing T14 was standardised and ordered into production as the Half-track M2. The half-track was envisaged as an artillery prime mover, the M2 being equipped to tow the 105 mm field howitzer and carry its crew and ammunition. This had been the original role of the French Citroen-Kegresse. The successful use of the Hanomag half-track in the armoured infantry role by the Germans in 1940 demonstrated that such a vehicle would be very useful to the US Army, so the existing T14/M2 design was adapted as an infantry carrier, with seats for infantry and stowage for their arms and equipment. Under the designation Half-track Personnel Carrier M3 this vehicle became known and more widely used than the original M2. While the M2 had internal ammunition lockers, the M3 body was 10 inches longer with a rear door. The later model M3A1, had a 'pulpit' to take an AA machine gun, while the M3 itself had a simple pedestal mount.

The US Forces made a study of the German campaigns in Europe in 1940 and appreciated that anti-aircraft defence of ground forces would be vital in any future operations where similar 'blitzkrieg' tactics involving close Luftwaffe air support would probably be encountered again. In order to produce anti-aircraft vehicles quickly it was realised that the existing half-track design was big and stable enough to be adapted, though as a long term aim the Ordnance Department developed full-track AA vehicles such as the M19. Mean-

while some half-track designs were quickly produced, the T1E1 with Bendix turret, T1E2 with Maxson turret, and T1E3 with Electro-dynamic turret. These were M2 vehicles with the turret placed in the rear compartment. The turrets were of aircraft type, the T1E3 even retaining the perspex canopy. The effectiveness of the idea was proved, the Maxson turret of the T1E2 being preferred. A production prototype, T1E4, was built, with the Maxson turret on a M3 vehicle. Standardised as Multiple Gun Motor Carriage M13, over 500 were built. An improved model, with four .50 cal machine guns was produced in April 1942, the prototype being designated GMC T58. This was standardised as Gun Motor Carriage M16, and 724 were built by White Motor Co in 1942-3. A similar vehicle (but with flat section mudguards and rounded super-structure corners) was the M17 built by International Harvester Co on the similar Half-track M5, over 1,000 of these were made.

*Bereits Anfang der 30 er Jahre wurden Halbkettenfahrzeuge (Half-tracks) für die US Armee entwickelt, nachdem das Heereswaffenamt die Erfolge der Citroen-Kegresse Fahrzeuge sehr sorgfältig registriert hatte.*

*Verschiedene Firmen arbeiteten an der Entwicklung. Produziert wurde das erste Fahrzeug von der Gunningham Motor Company 1932 mit der Bezeichnung T1.*

*1940 hatte die Entwicklung bereits zum T14 geführt.*

*Nach Eintreten in den europäischen Krieg, begann die US ein grosses Aufrüsten und im September der T14 als M2 Half-track zur Produktion freigegeben.*

*Wie vorgesehen, wurde der M2 als Artillerie Zugmaschine eingesetzt, zum Schleppen der 105 mm Feldhaubitze einschliesslich der Bedienungsmannschaft und Munition.*

*Die erfolgreichen Einsätze der deutschen Halbkettenfahrzeuge "Hanomag Sd.Kfz. 251" bei den deutschen Panzergranadiere in Polen und Frankreich Feldzug blieben der US Heeresleitung nicht verborgen und führten zu der Erkenntnis, dass diese Fahrzeuge nicht nur reine Zugmas-*

*chinen sind, sondern viel mehr Verwendungsmöglichkeiten hatten.*

*Beim Eintritt der US in den Krieg, waren natürlich viele militärische Objekte durch die Erfolge der Deutschen beeinflusst.*

*Um den bestehenden T14 - M2 als Mannschaftstransporter einsetzen zu können, mussten natürlich einige Änderungen vorgenommen werden. Geschützte Sitze für 10 Mann, Platz für Waffen und Munition, verlängertes Chassis um 10 inch und eine Ausstiegstüre ergaben den Half-track Personal Carrier M3, welcher mehr Verwendung bot und eingesetzt wurde als der ursprüngliche M2.*

*Der M3 wurde Standardausrüstung für Sturmtruppen im ganzen WW II und noch Jahre danach in vielen Nationen eingesetzt.*

*Die US Streitkräfte erkannten aber auch, dass eine Flugzeugabwehr vom Boden aus lebenswichtig war, um in jeder zukünftigen und ähnlichen Operation wie im Blitzkrieg erfahren, der Luftwaffenunterstützung entgegenzutreten zu können.*

*Das Heereswaffenamt entwickelte das Vollkettenfahrzeug AA M19, waren aber auch überzeugt, dass die vorhandenen Halbkettenfahrzeuge verwendet werden könnten.*

*Es erschien der T1E1 mit Bendix Turm, der T1E2 mit Maxson Turm und der T1E3 mit Electric Dynamic Turm. Es waren Fahrzeuge der M2 Serie mit dem Geschütz auf dem hinteren Teil des Chassis, Geschütze ähnlich in den Flugzeugen.*

*Die Wirksamkeit erprobt - und der Maxson Turm zur Produktion freigegeben. Ein Prototyp T1E4 wurde gebaut auf Fahrgestell des M3. Standardisiert als Multiple Gun Motor Carriage M13 und mehr als 500 Fahrzeuge ausgeliefert. 1942 wurden weitere Verbesserungen vorgenommen und der erste Prototyp erschien im April mit vier .50 cal Schnellfeuerkanonen. Bez. GMC T58 Als M16 wurden dann 1942 - 43 rund 724 Fahrzeuge von White Motor Comp. gebaut. International Harvester Co. konnten rund 1000 solcher Fahrzeuge jedoch mit flachen Schutzblechen und abgerundeten Aufbauten als M17 zur Auslieferung bringen.*





**READ BEFORE ASSEMBLY.**  
**ERST LESEN — DANN BAUEN.**

- ★ Study the instructions and photographs before commencing assembly.
- ★ You will need a sharp knife, a pair of pliers, a file, and a pair of tweezers.
- ★ Vor Beginn die Bauanleitung studieren und den Nummern nach die Elemente zusammenbauen.
- ★ Kleine Teile hält man mit Pinzette fest.

In the assembly drawings, complicated surfaces to be cemented are printed in this way. Also, surfaces indicated with arrows should be cemented.

Schwierige Klebestellen.  
 Vorsichtig kleben.

**1** Complete picture  
 Komplette Abbildung

Select in either open or closed position as shown in the photographs. Accessory Parts may be done with reference to the photographs and your additional material or your reference.

Kann offen oder geschlossen gebaut werden. Zubehör wie gezeigt anbringen.

**2** Machine Gun Bases  
 M.G. Lafette

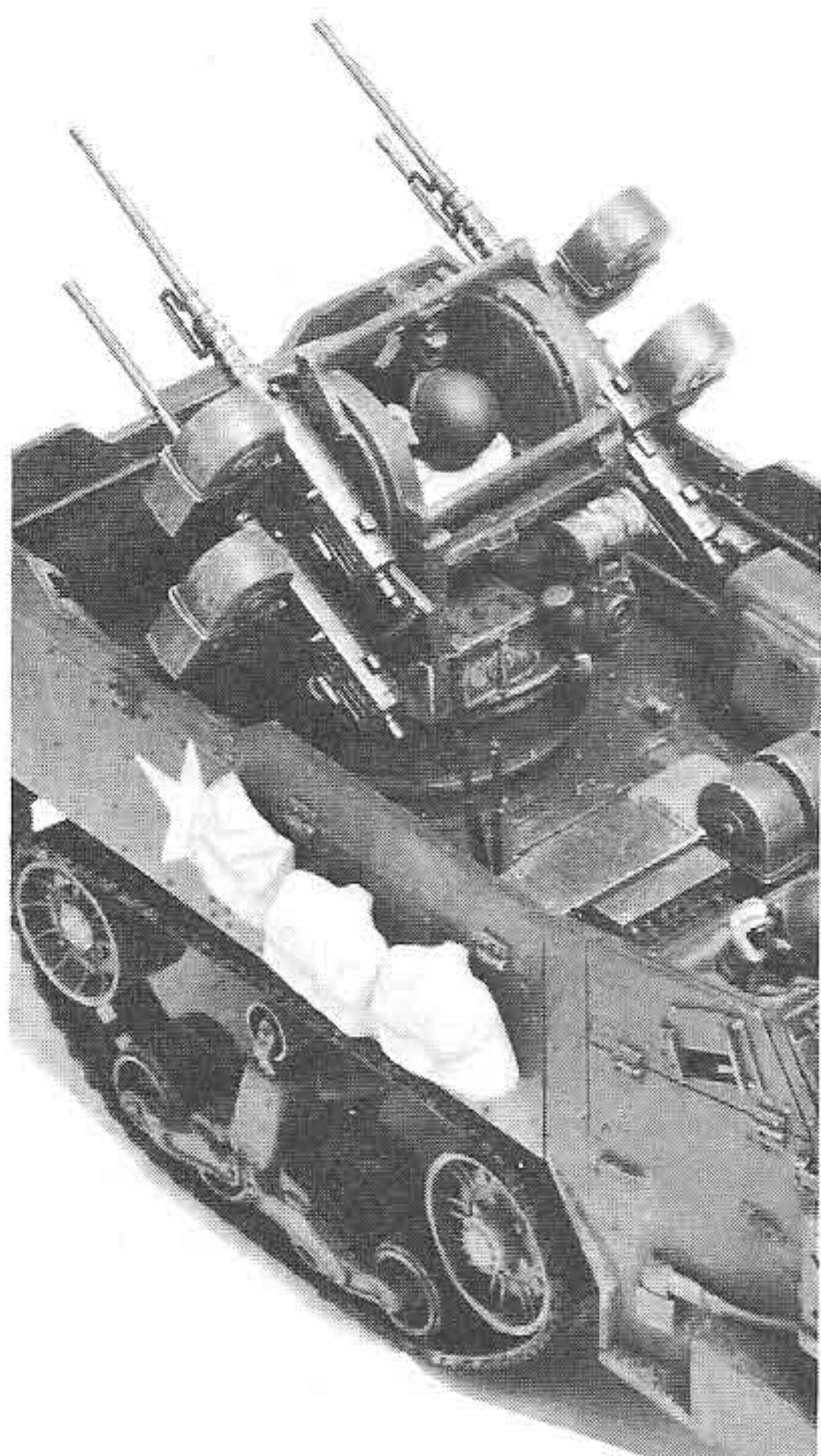

**1** Complete picture  
 Komplette Abbildung

«In Rest»

Can be fixed either in open or closed state.  
 Kann eingebaut werden entweder offen oder geschlossen.

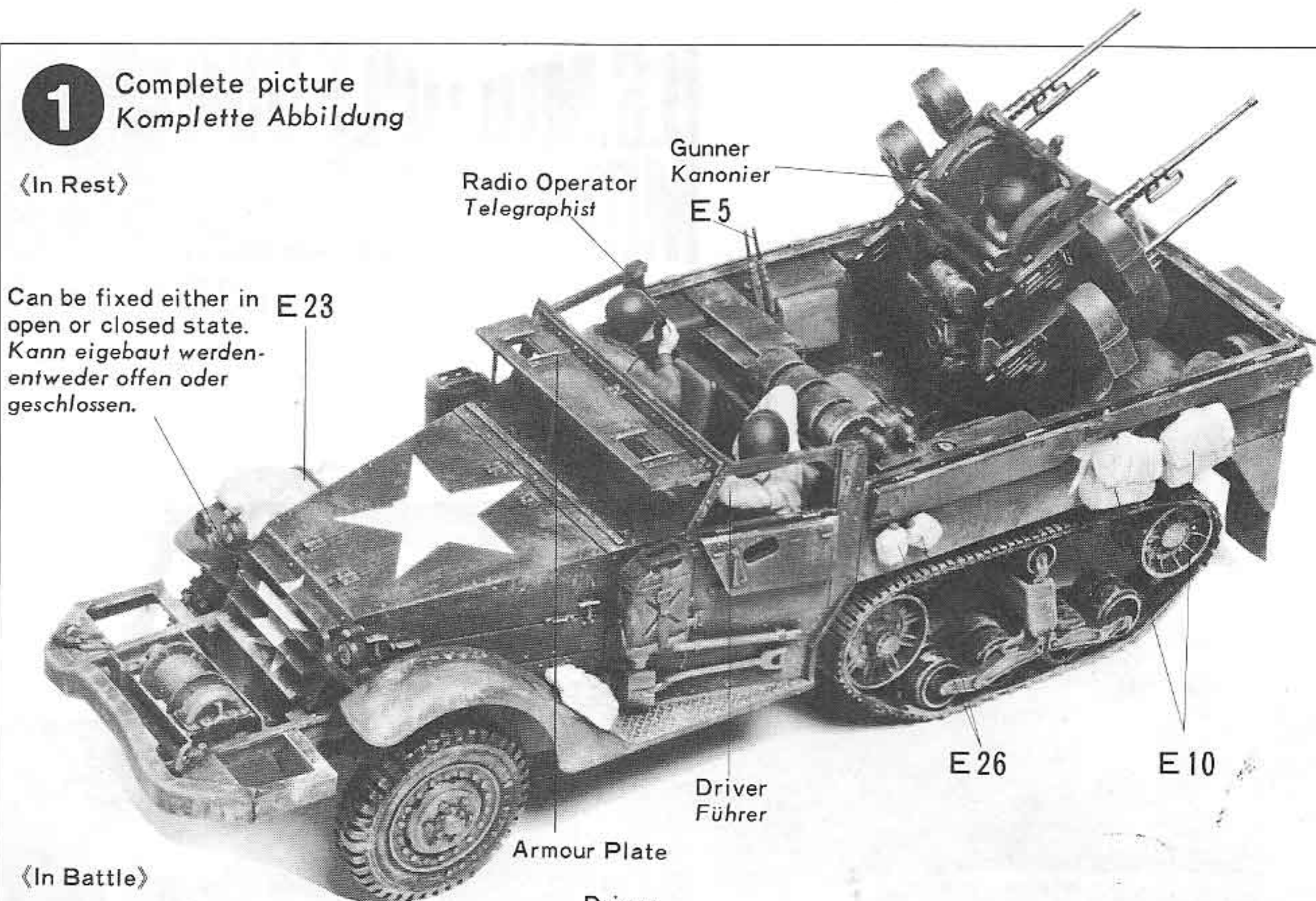

«In Battle»

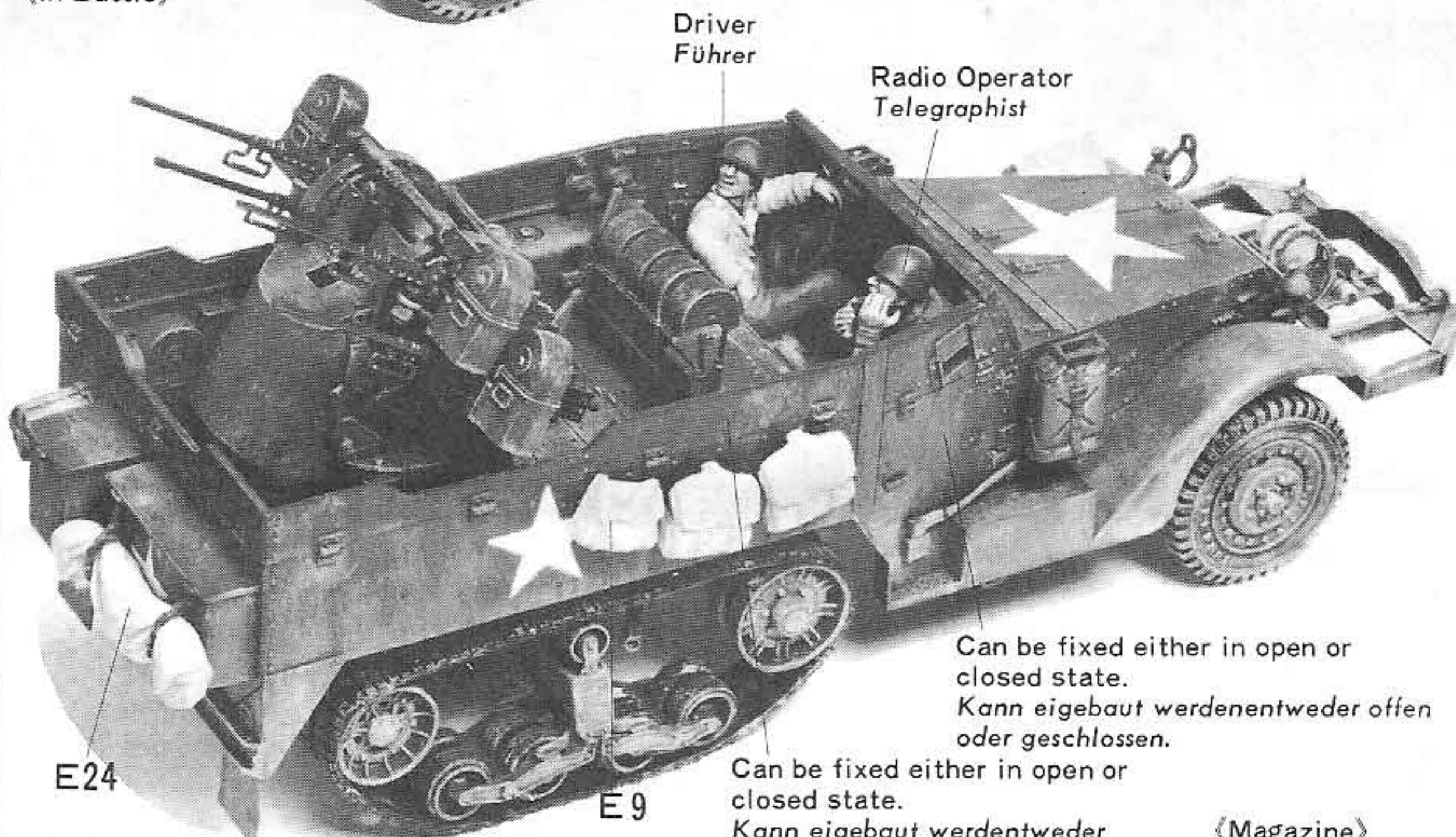

Can be fixed either in open or closed state.  
 Kann eingebaut werden entweder offen oder geschlossen.

Can be fixed either in open or closed state.  
 Kann eingebaut werden entweder offen oder geschlossen.

**2** Construction of Machine Gun Bases  
 Bau der M.G. Lafette

«Right»  
 «Rechts»

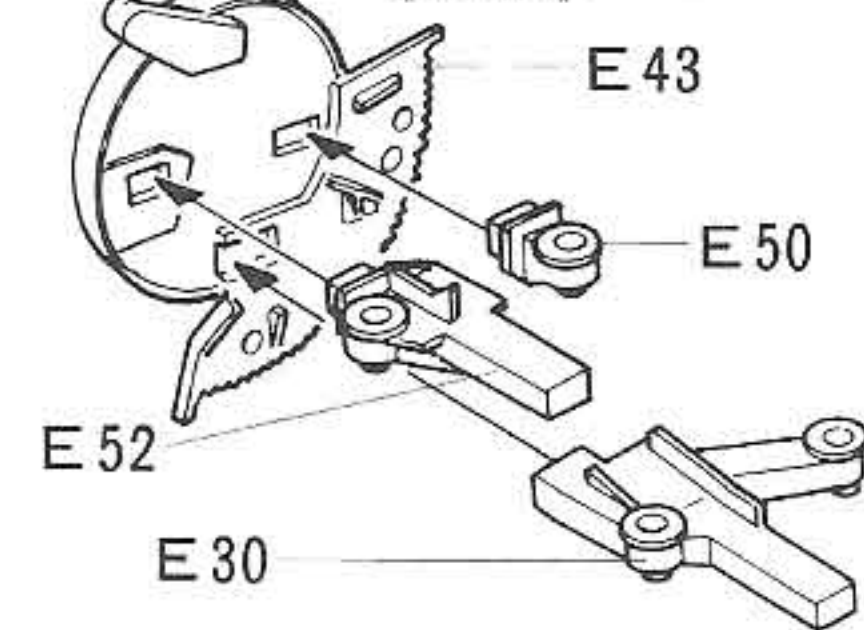

«Left»  
 «Links»

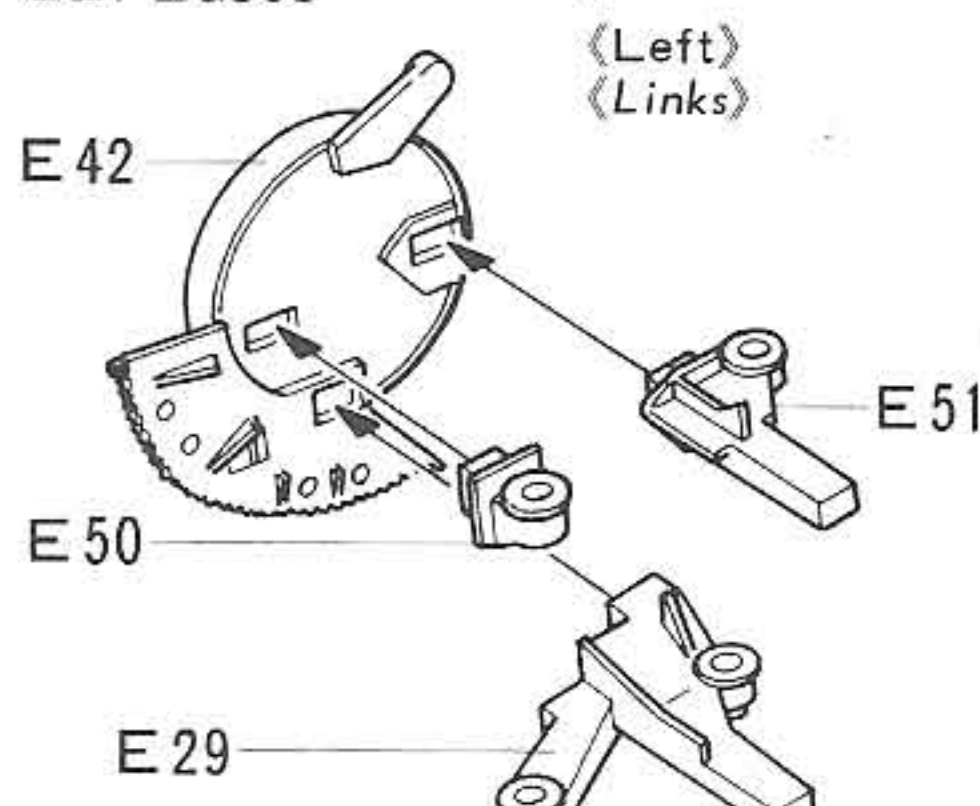

«Magazine»  
 «Magazin»

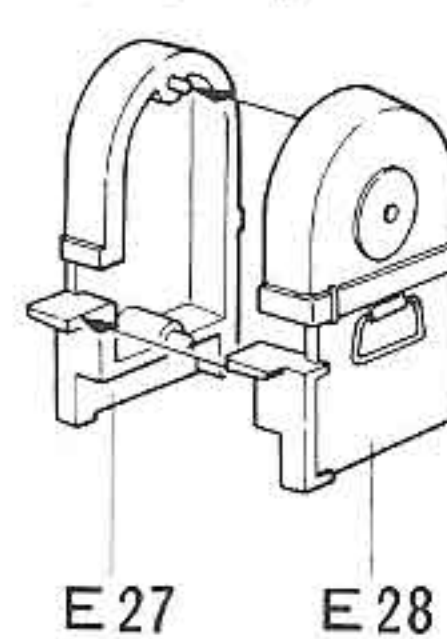

«Right»  
 «Rechts»

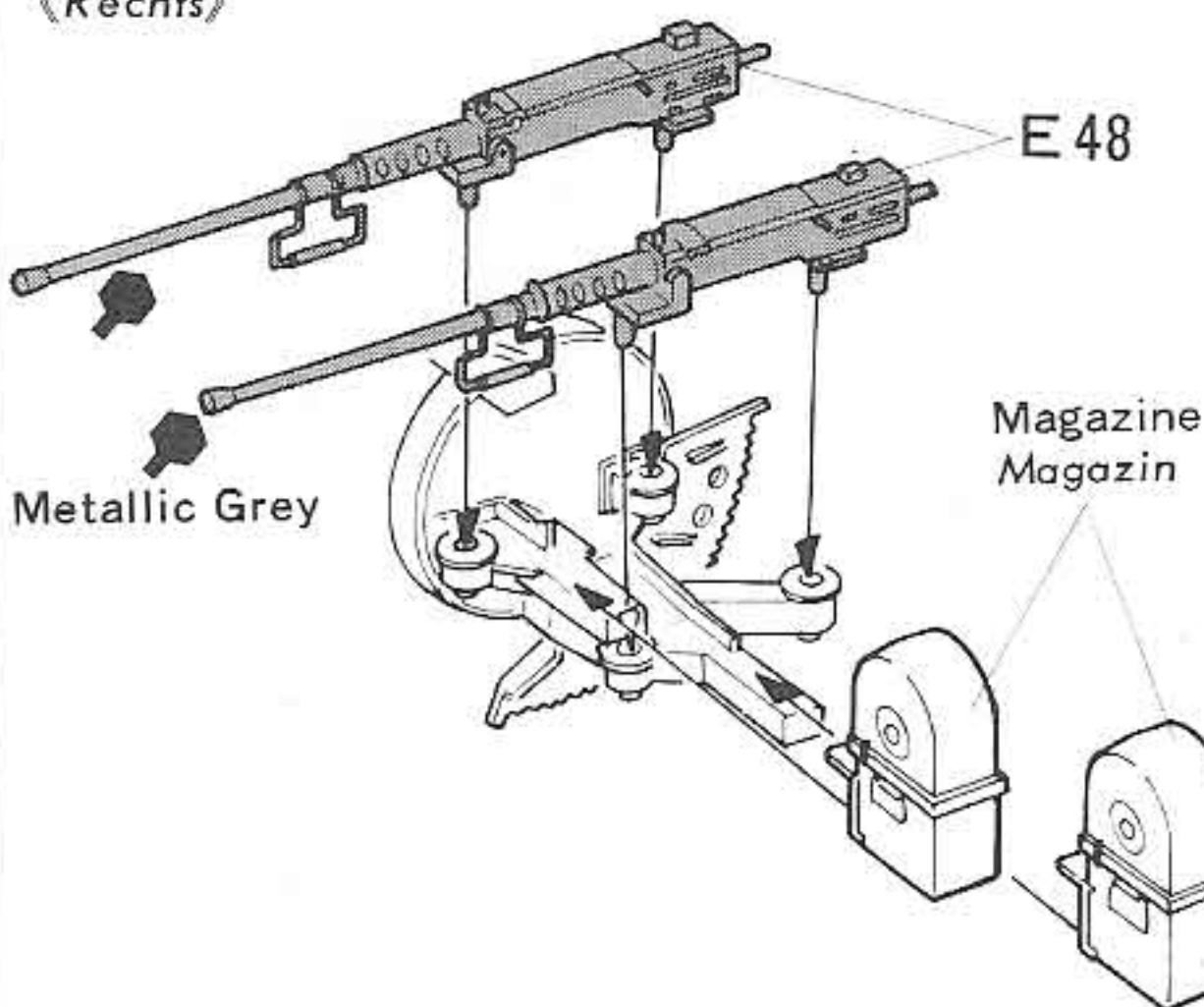

«Left»  
 «Links»

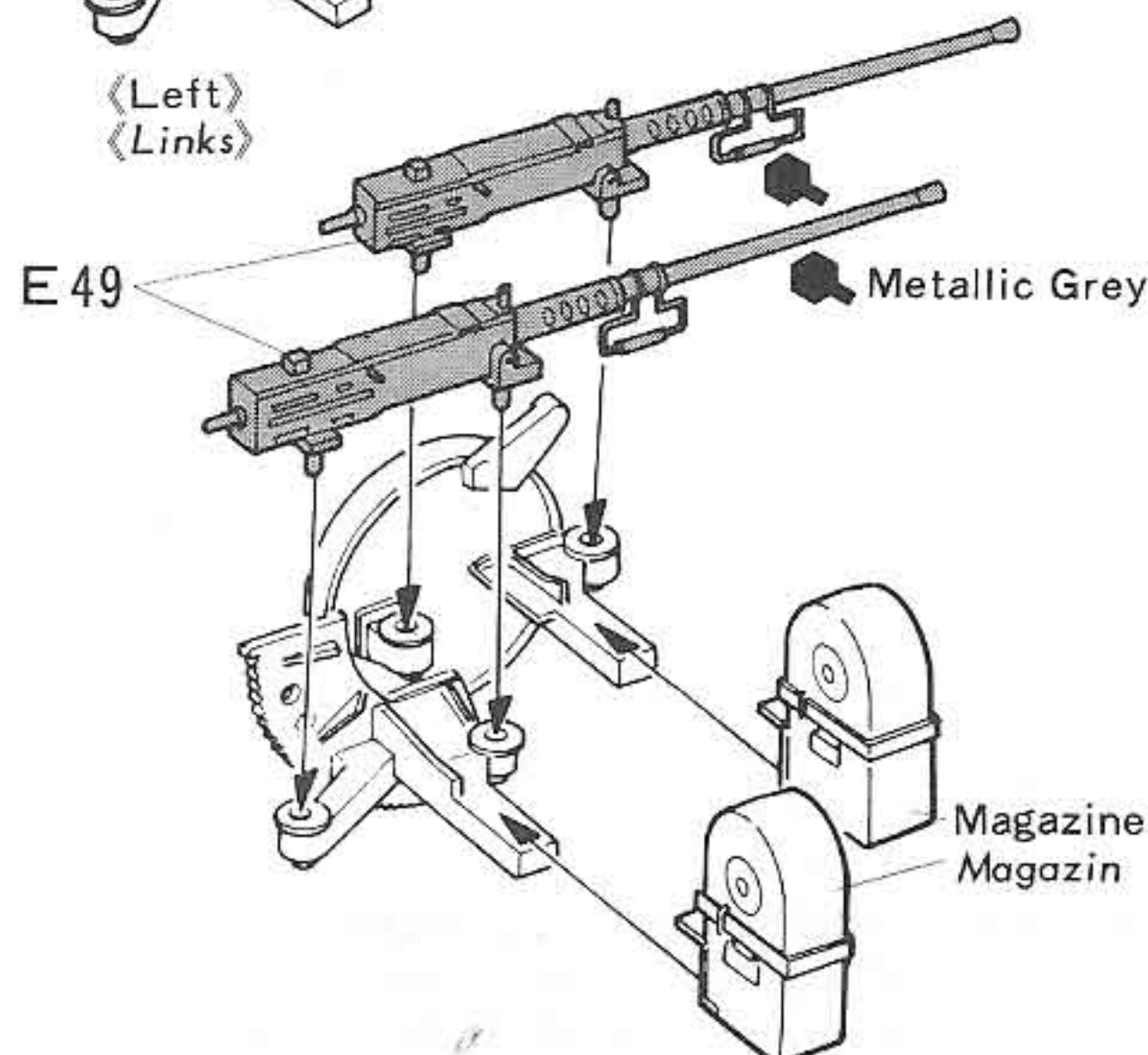



**4** <Fixing of Machine Gun Base>  
<Maschinengewehrstand>

Right and Left M.G. Base are designed to rotate with Sight.  
M.G. drehen mit Richtobjektiv.

**6** <Fixing of Chassis>  
<Bau des Chassis>

First fix Muffler  
Erst Auspuff einbauen

<Construction and Painting of Figures>  
<Männchenbau>

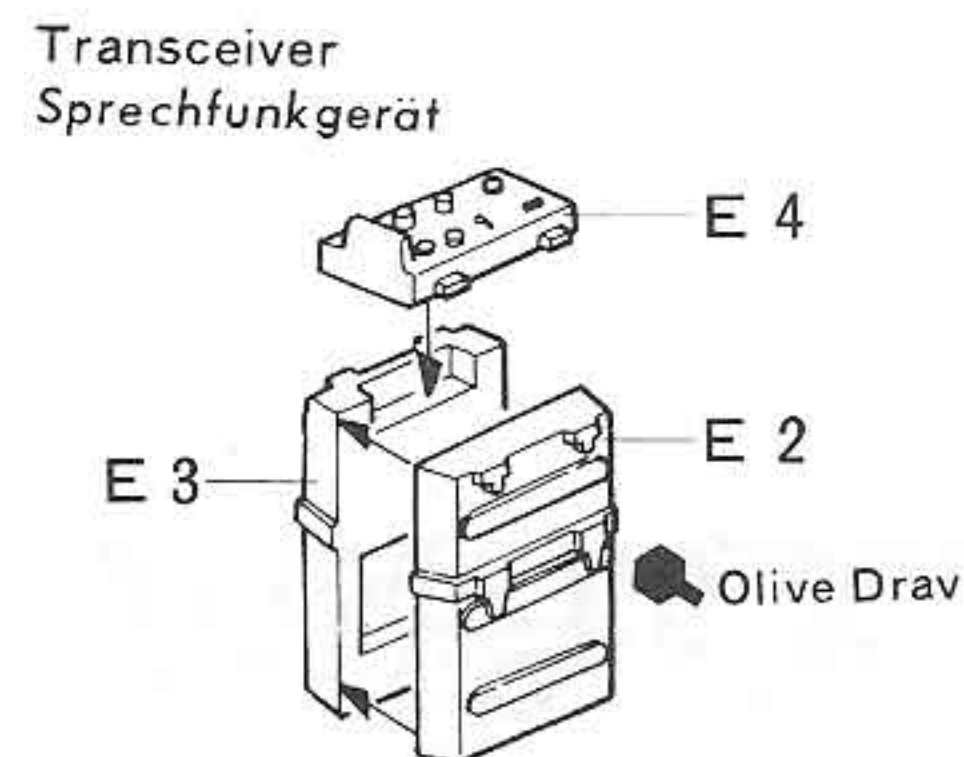
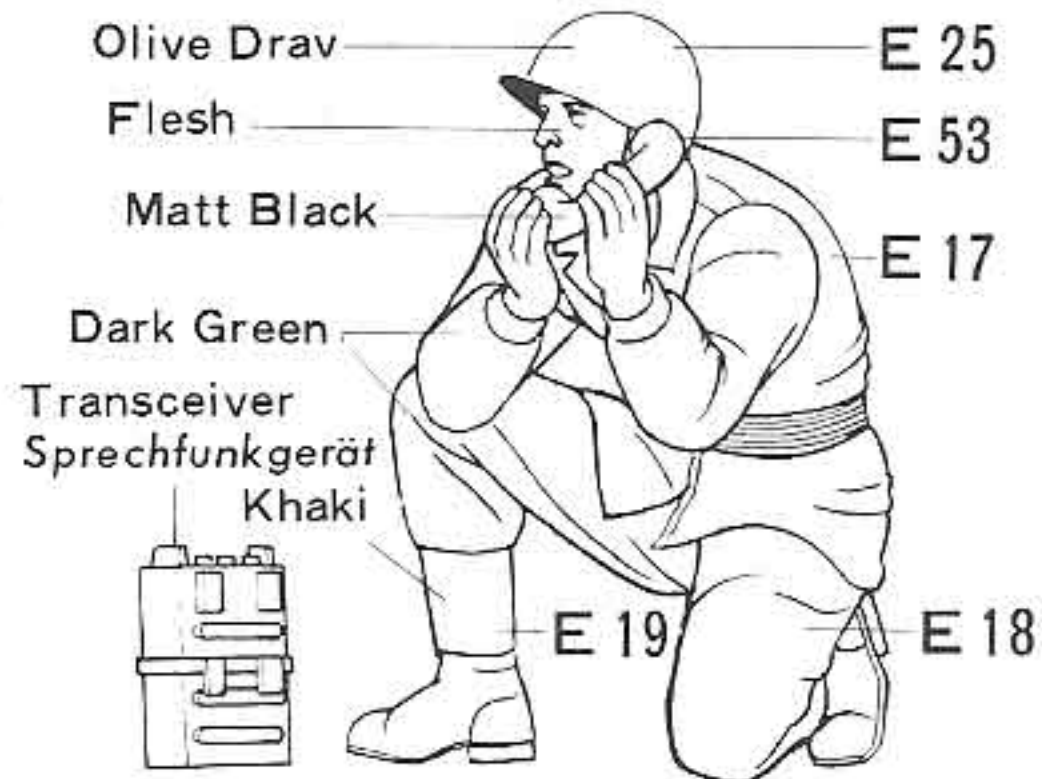

**3** Construction of Pedestal  
Construction des Sockels

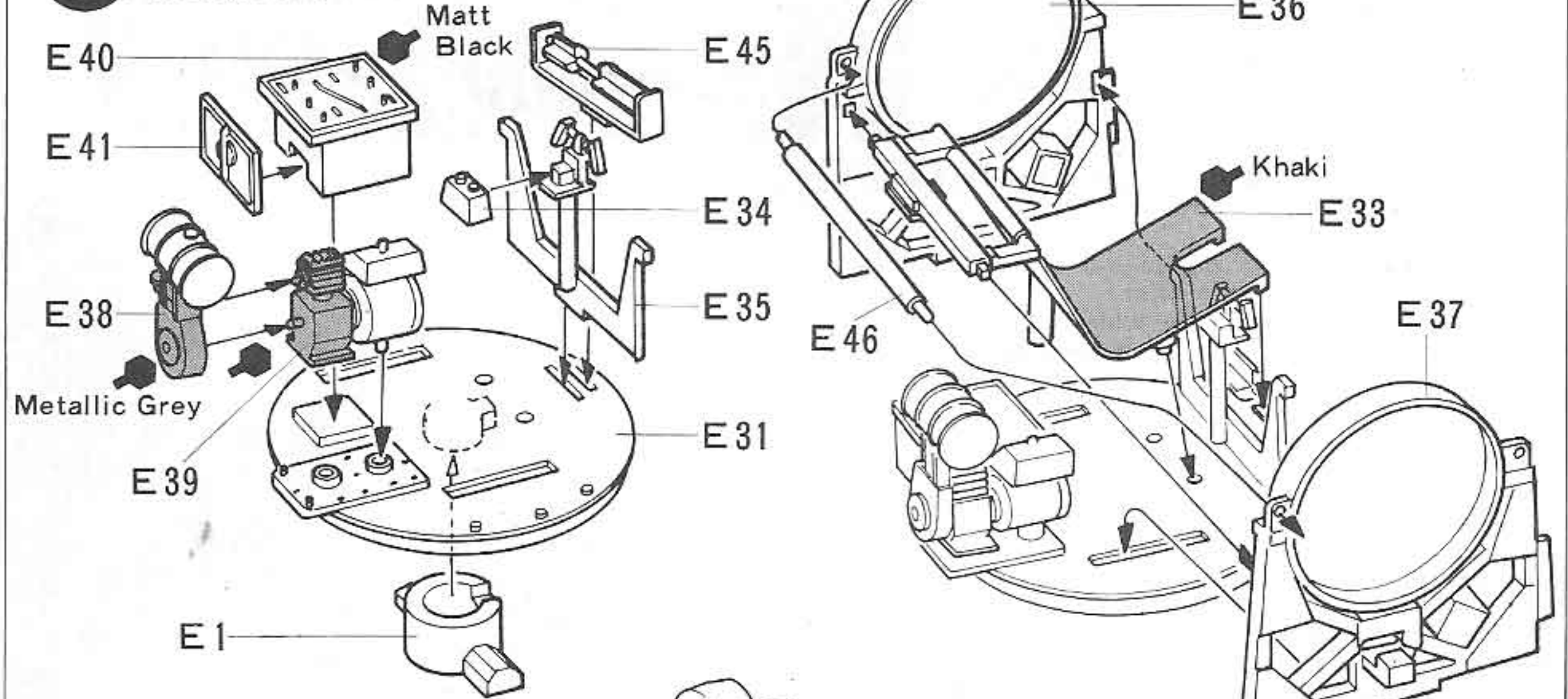

**4** Fixing of Machine Gun Base  
Maschinengewehrstand

<A Sight>  
<Richtobjektiv>

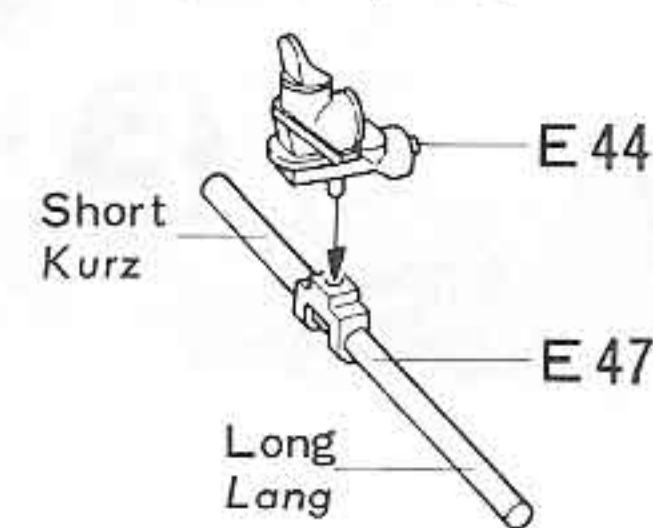

★Cement E32 after fixing figure.  
★E32 einkleben nach der figur.

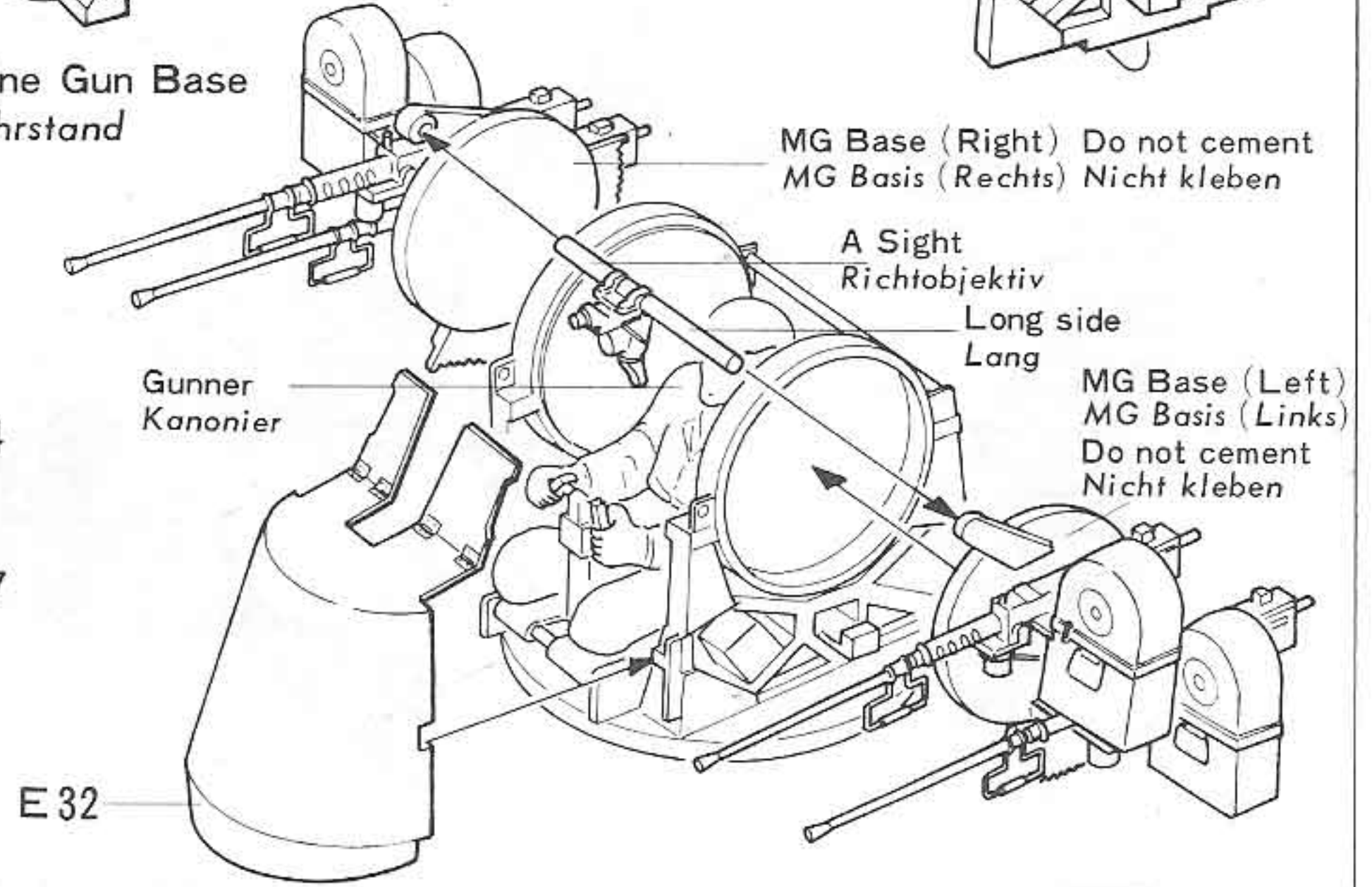

**5** Fixing of Engine  
Motoren Einbau

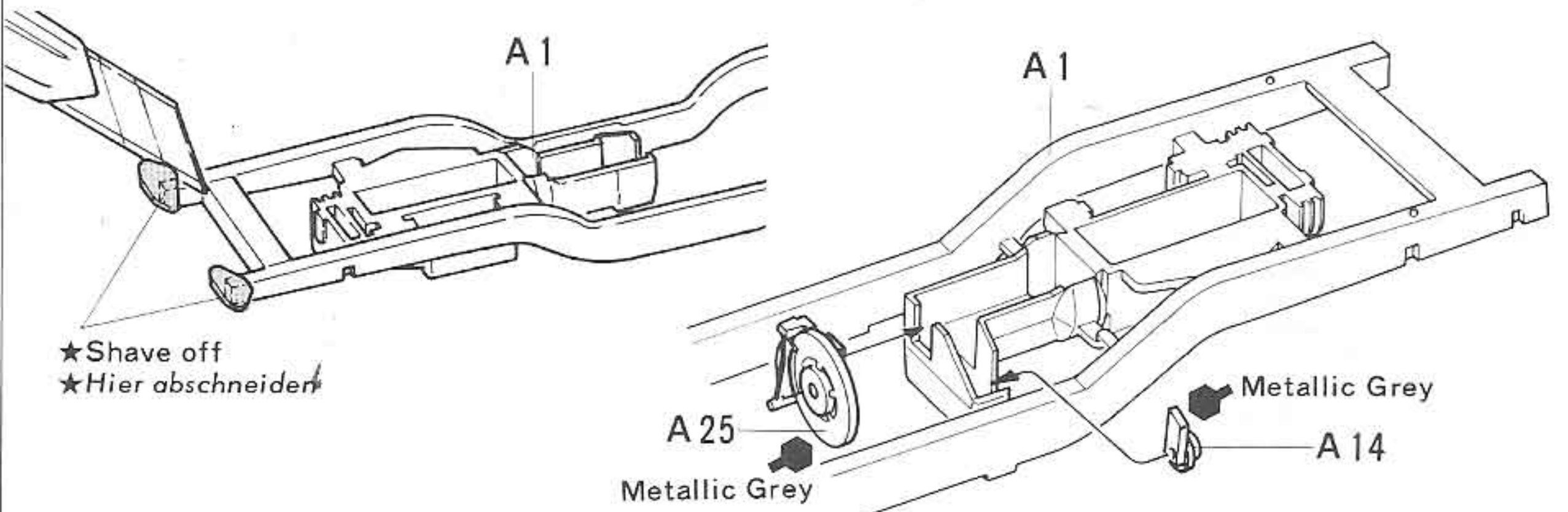

**6** Fixing of Chassis  
Bau des Chassis

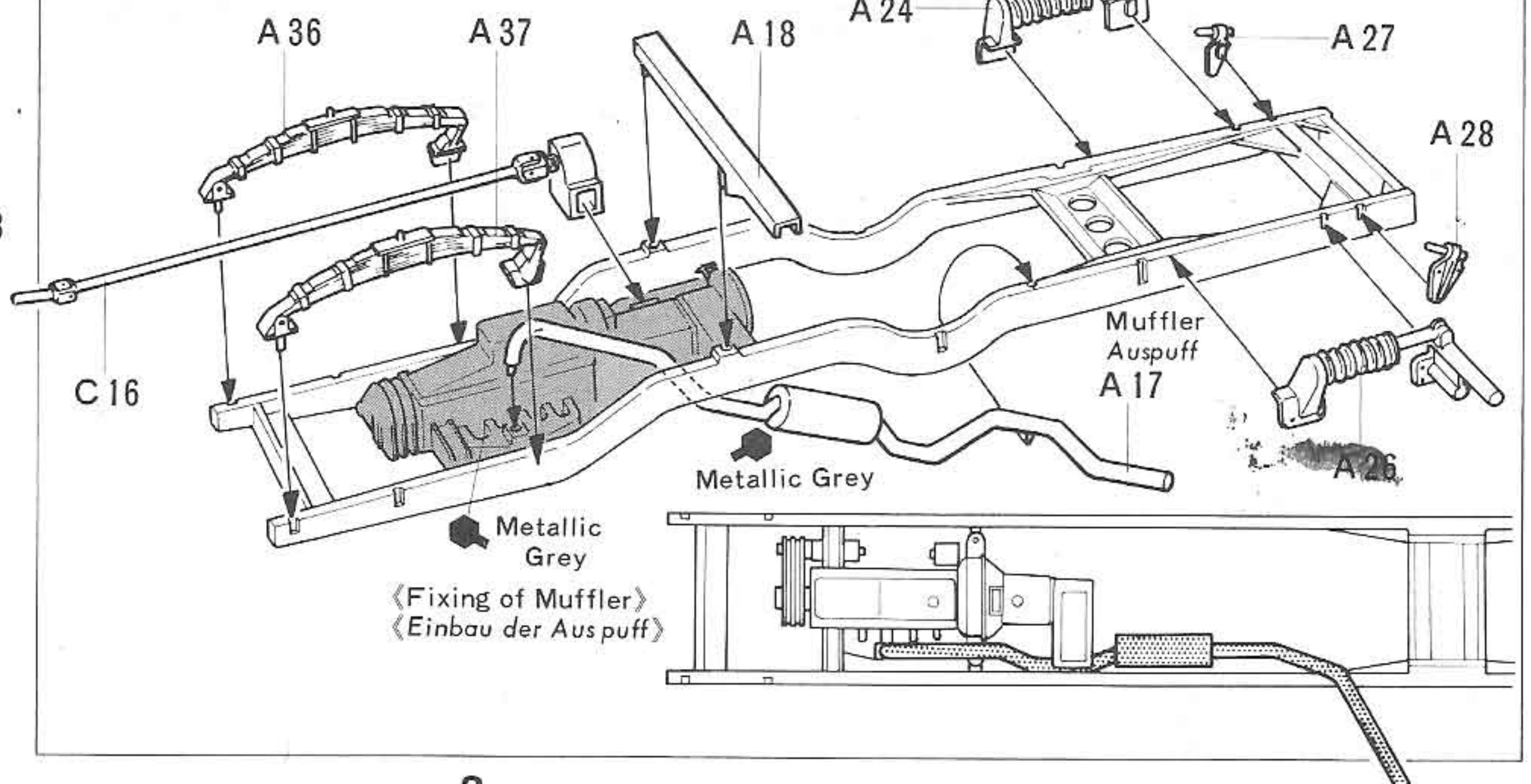

<Fixing of Muffler>  
<Einbau der Auspuff>



**8** <Construction of wheels>  
<Zusammenbau der Räder>  
Poly cap D2 and D3 do not cement.  
Poly cap D2 und D3 nicht kleben.

**9** <Construction of Suspension>  
<Construction der Radaufhängung>  
Road wheels are designed to rotate.  
Die Laufräder sind drehbar.

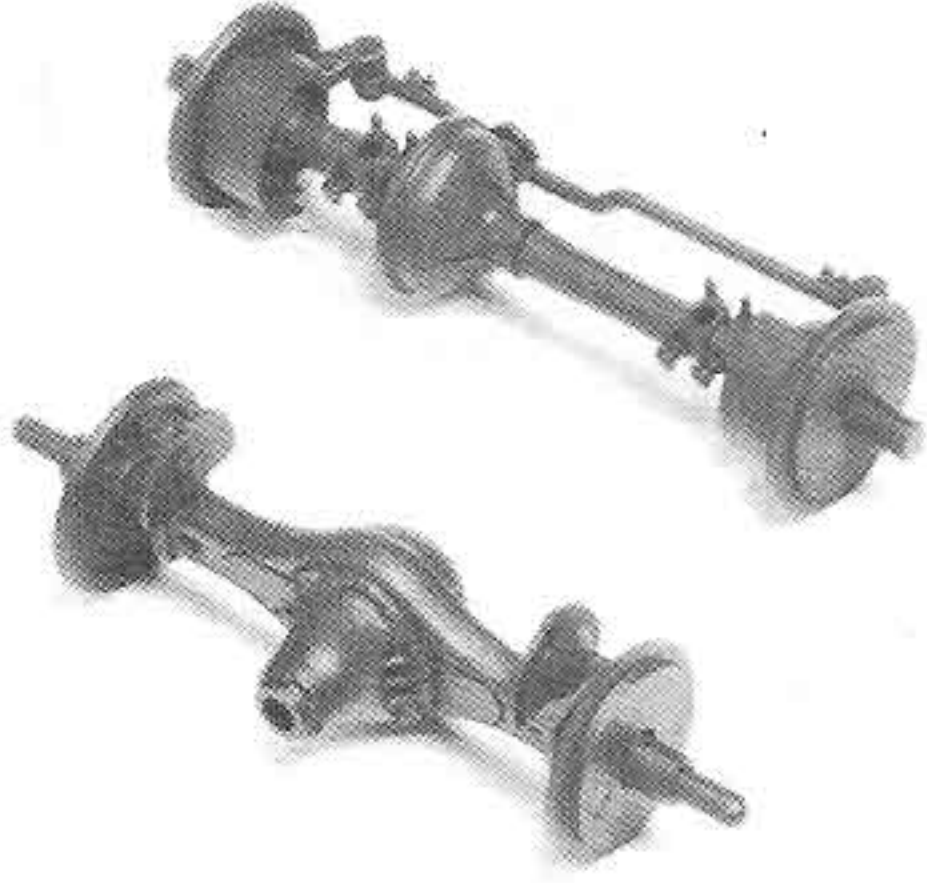

**10** <Fixing of Axles>  
<Einbau der Achsen>

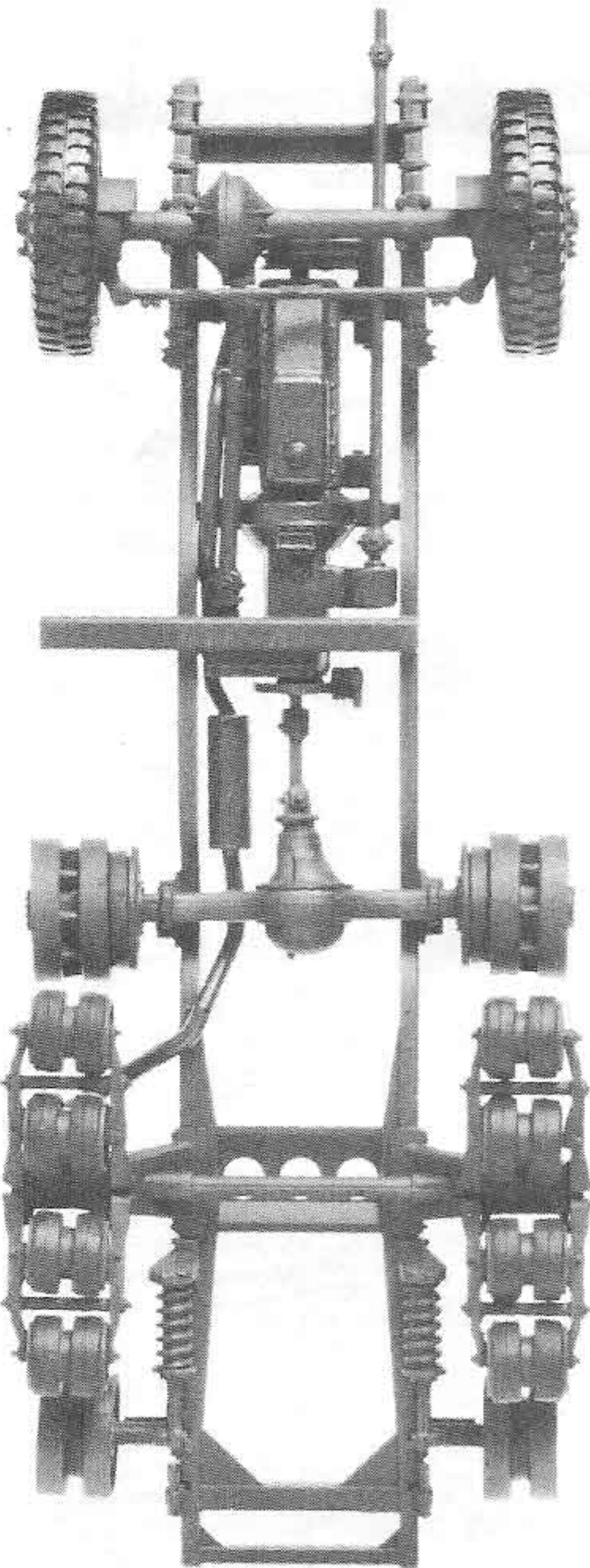

**7** Construction of Axles  
Construction der Achsen

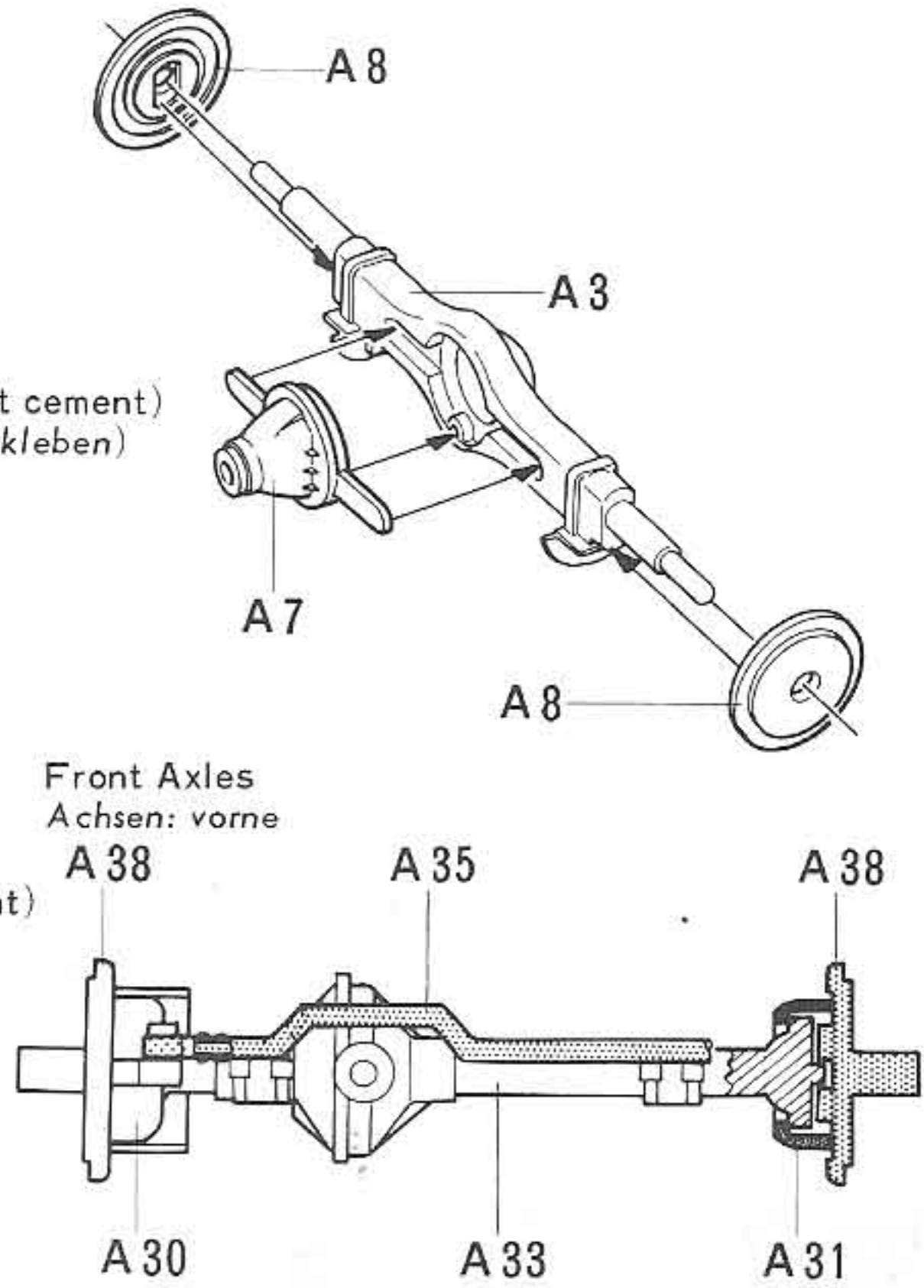
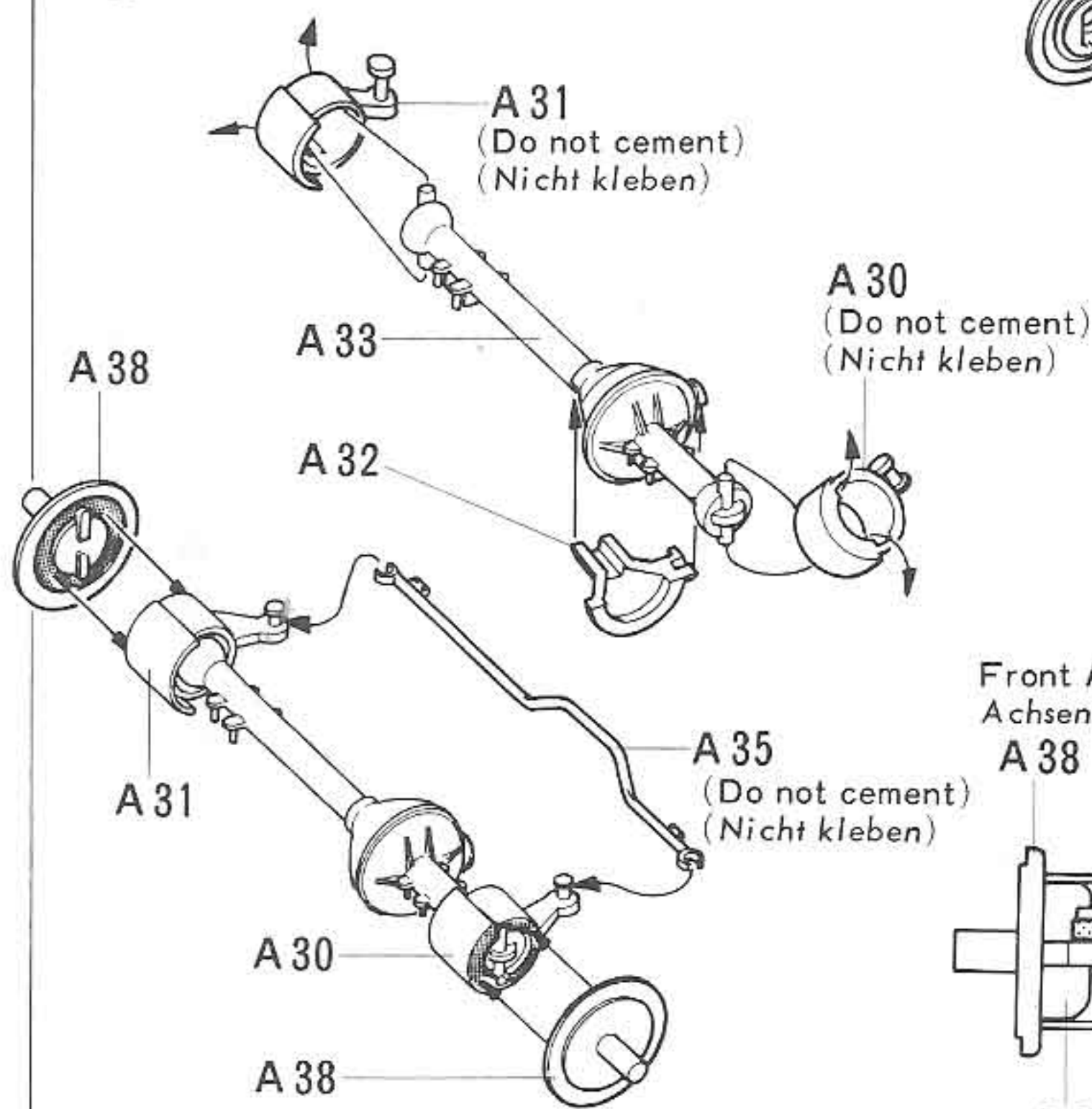

**8** Construction of Wheels  
Zusammenbau der Räder

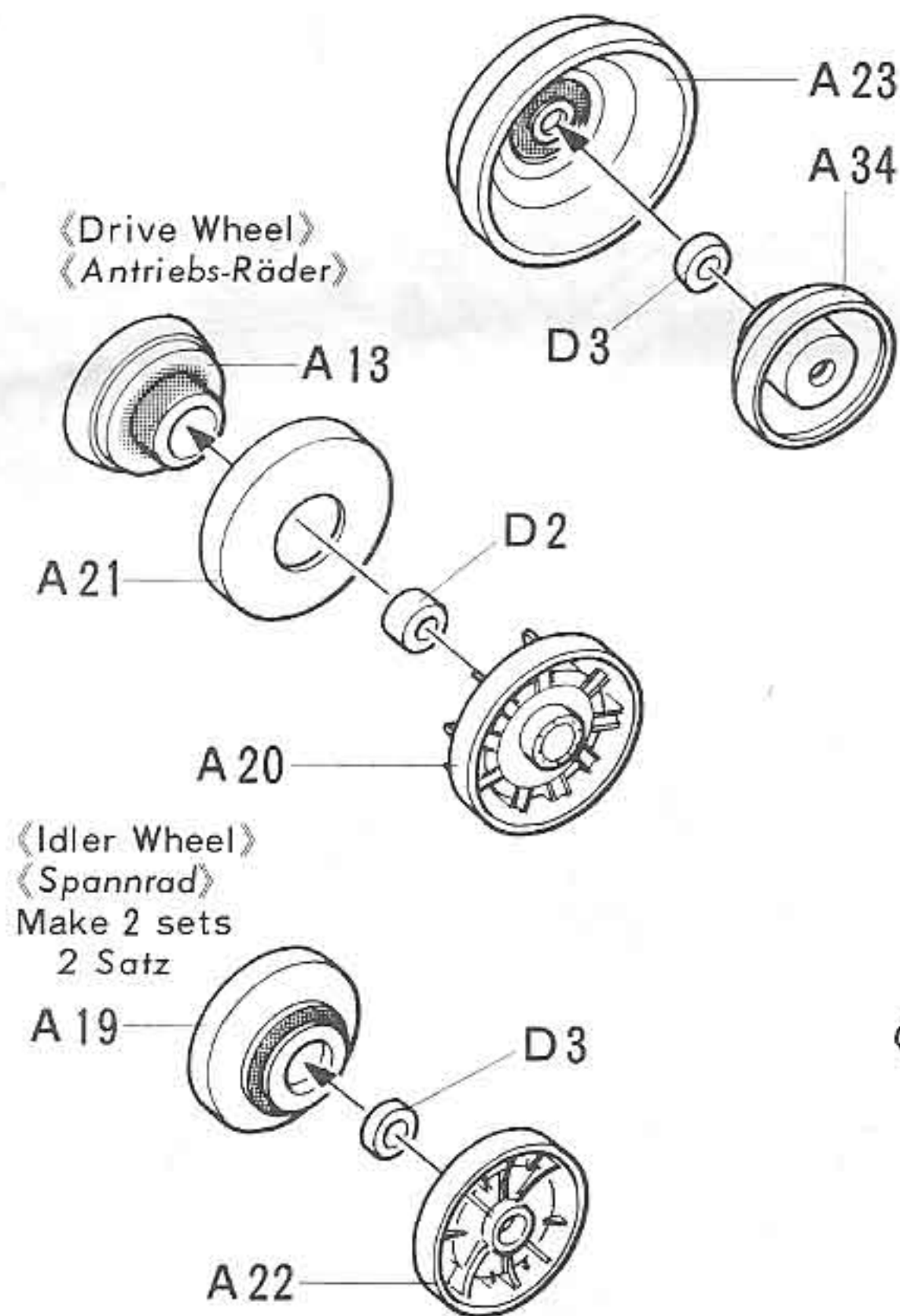

**9** Construction of Suspension  
Construction der Radaufhängung

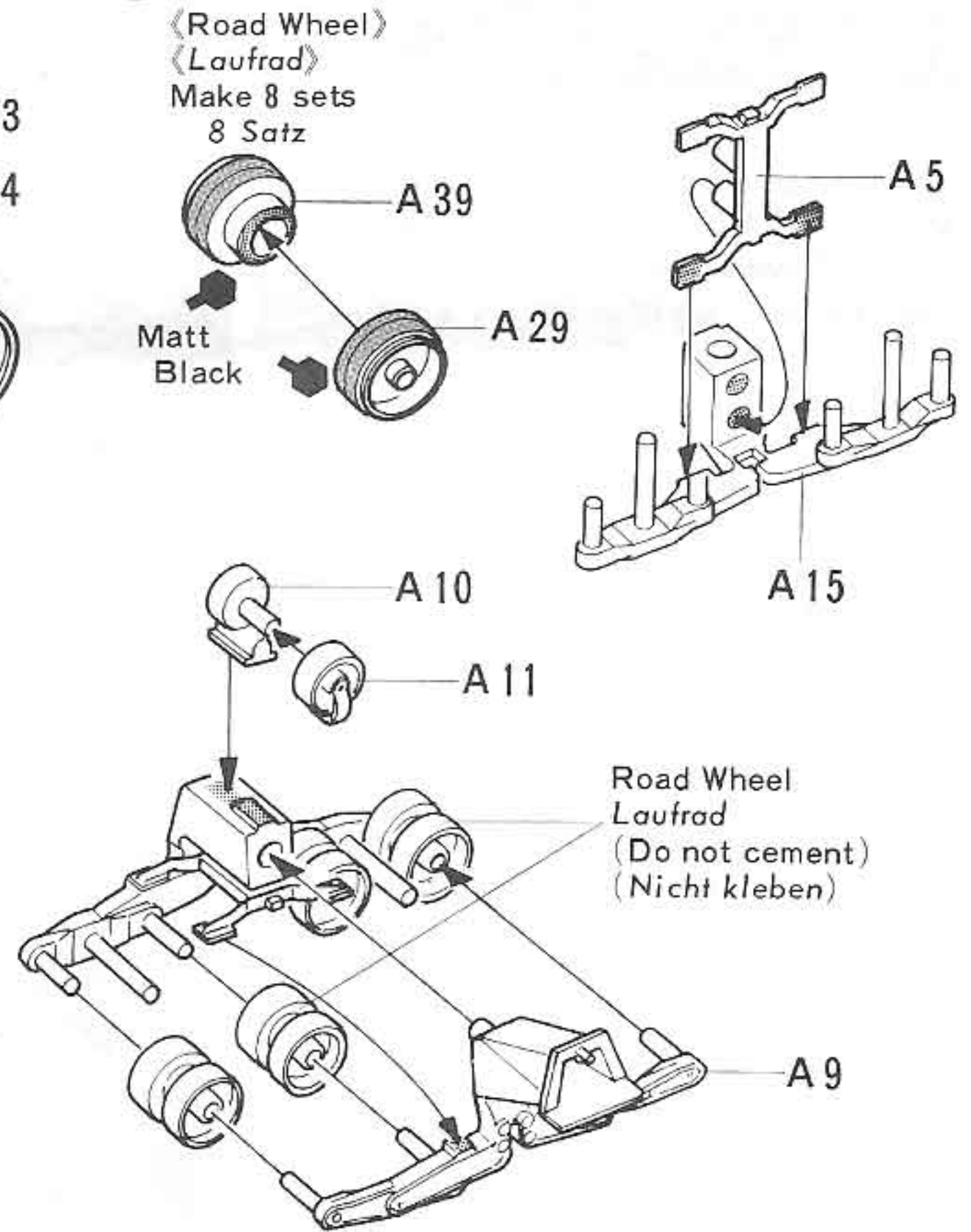

**10** Fixing of Axles  
Einbau der Achsen

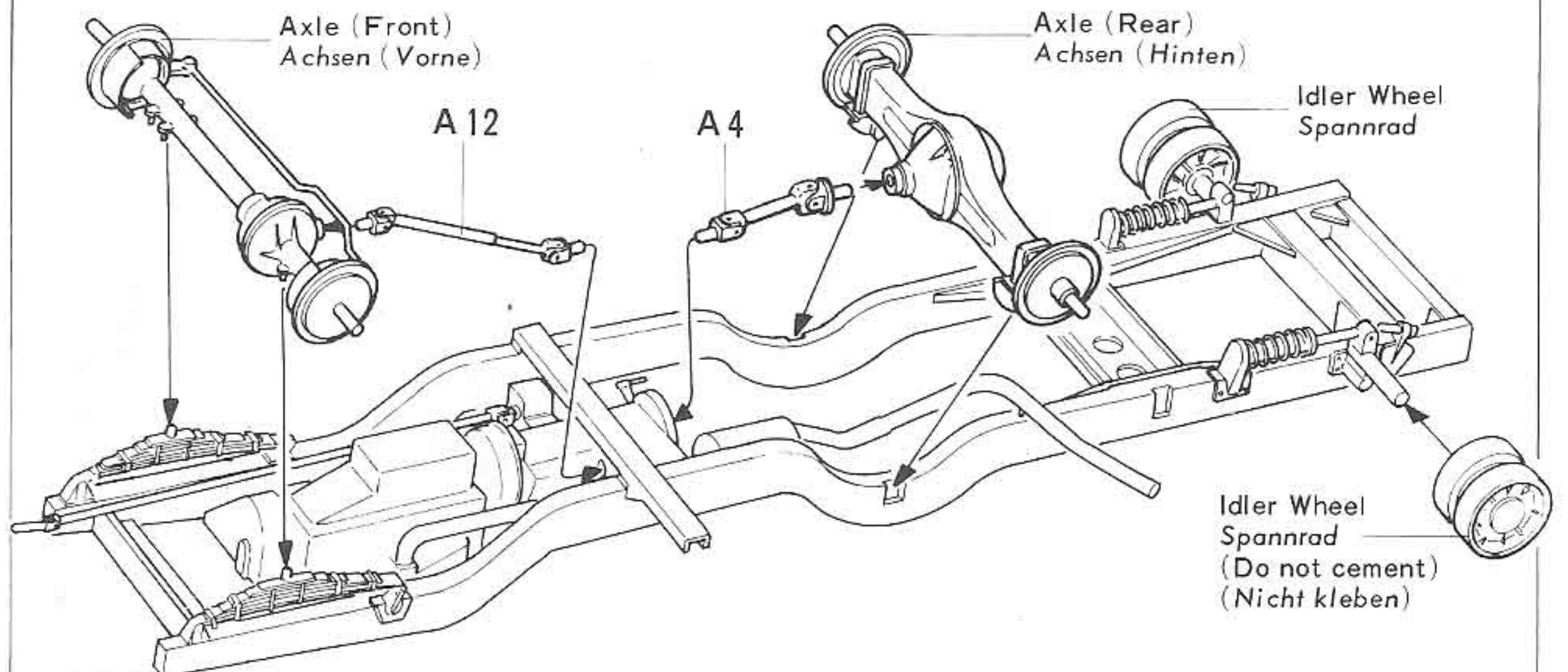



**11** <Construction of Cockpit>  
<Construction der Fahrersitz>

Transparent part for Windshield should be cut out with a knife or scissors as shown in the figure below. The end of Levers B30, B31, B33 and B37 should be painted in Matt Black.  
Transparentteil für Windschutzscheibe ausschneiden - siehe Bild. Die Knöpfe der Schalthebel B 30, B 31, B 33, B37 mattblack bemalen.

<Cutting out Windshield>  
<Windschutzscheibe>

Cut along this line  
Entlang der Linien schneiden

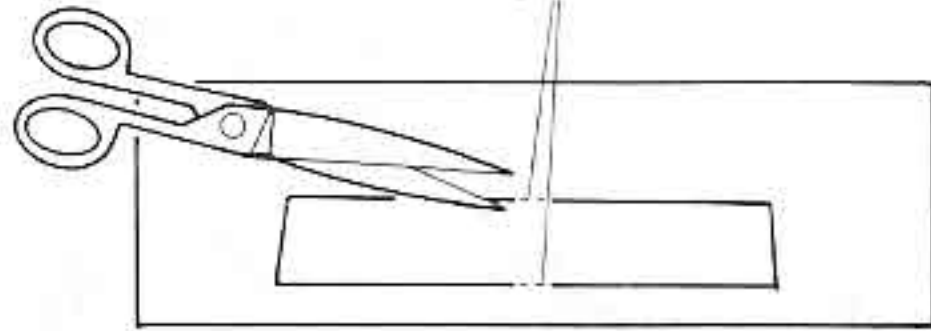

<Construction of Jerrycan>  
<Kanister>

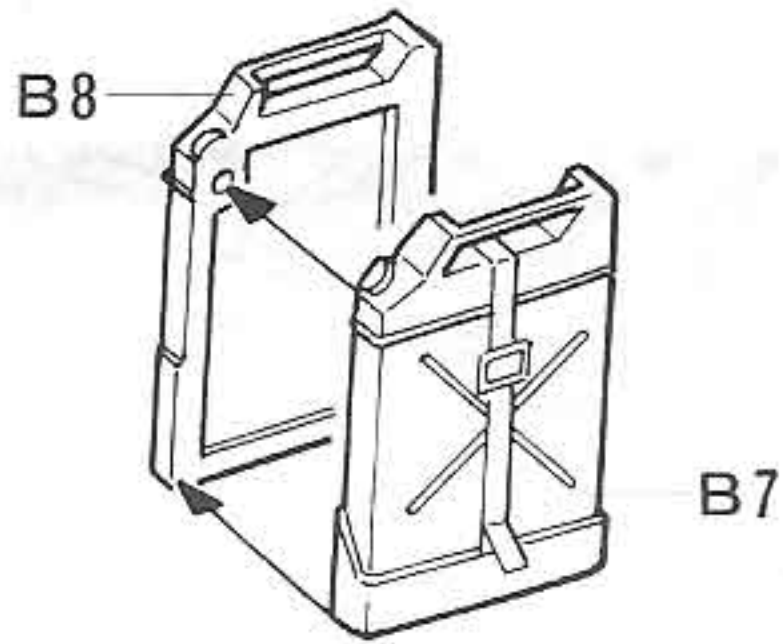

Make 2 sets  
2 Satz

<Radiator Grille>  
<Kühlergrill>

★ Select either B21 or B22.  
★ Entweder für B21 oder B22.

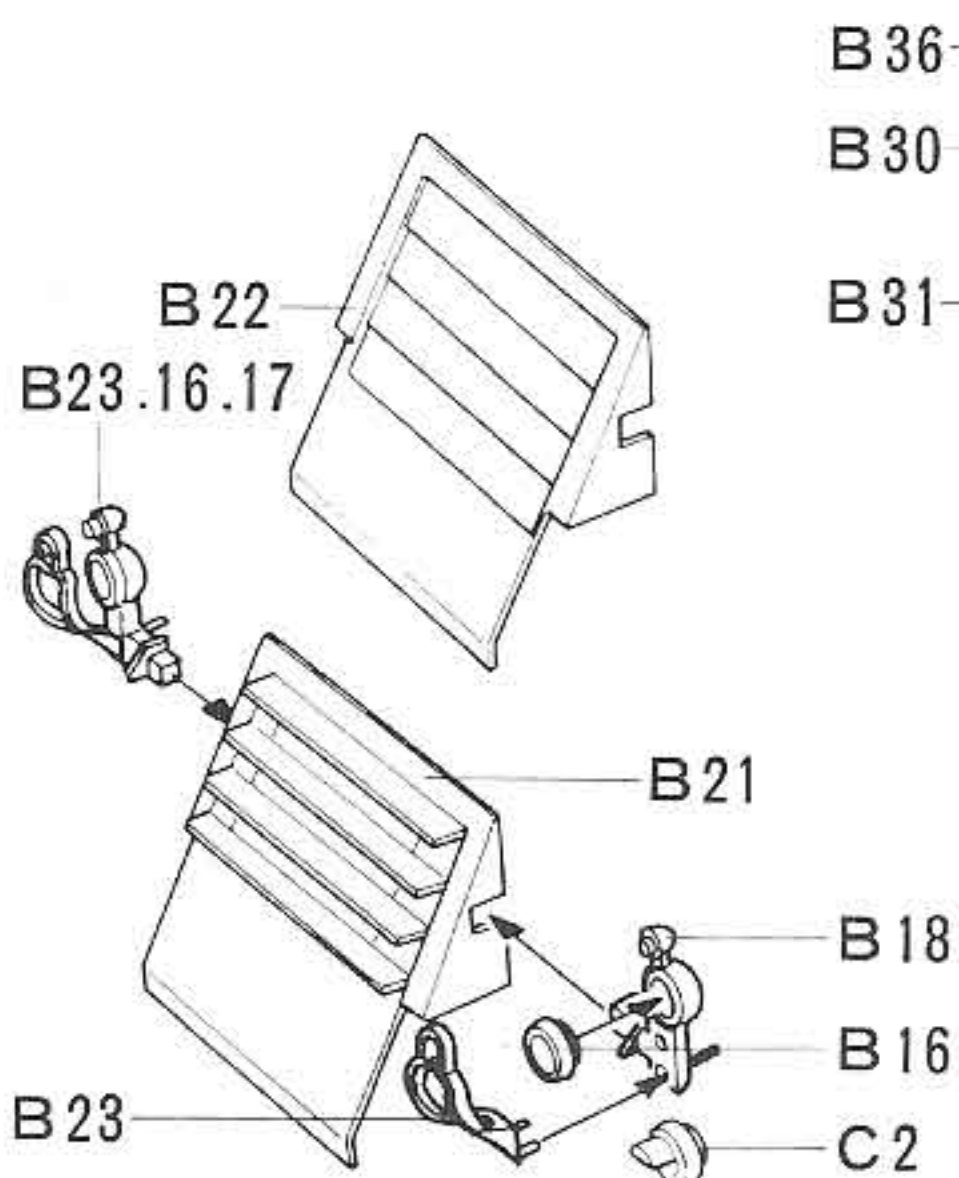

**11** Fixing of Suspension  
Einbau der Radaufhängung

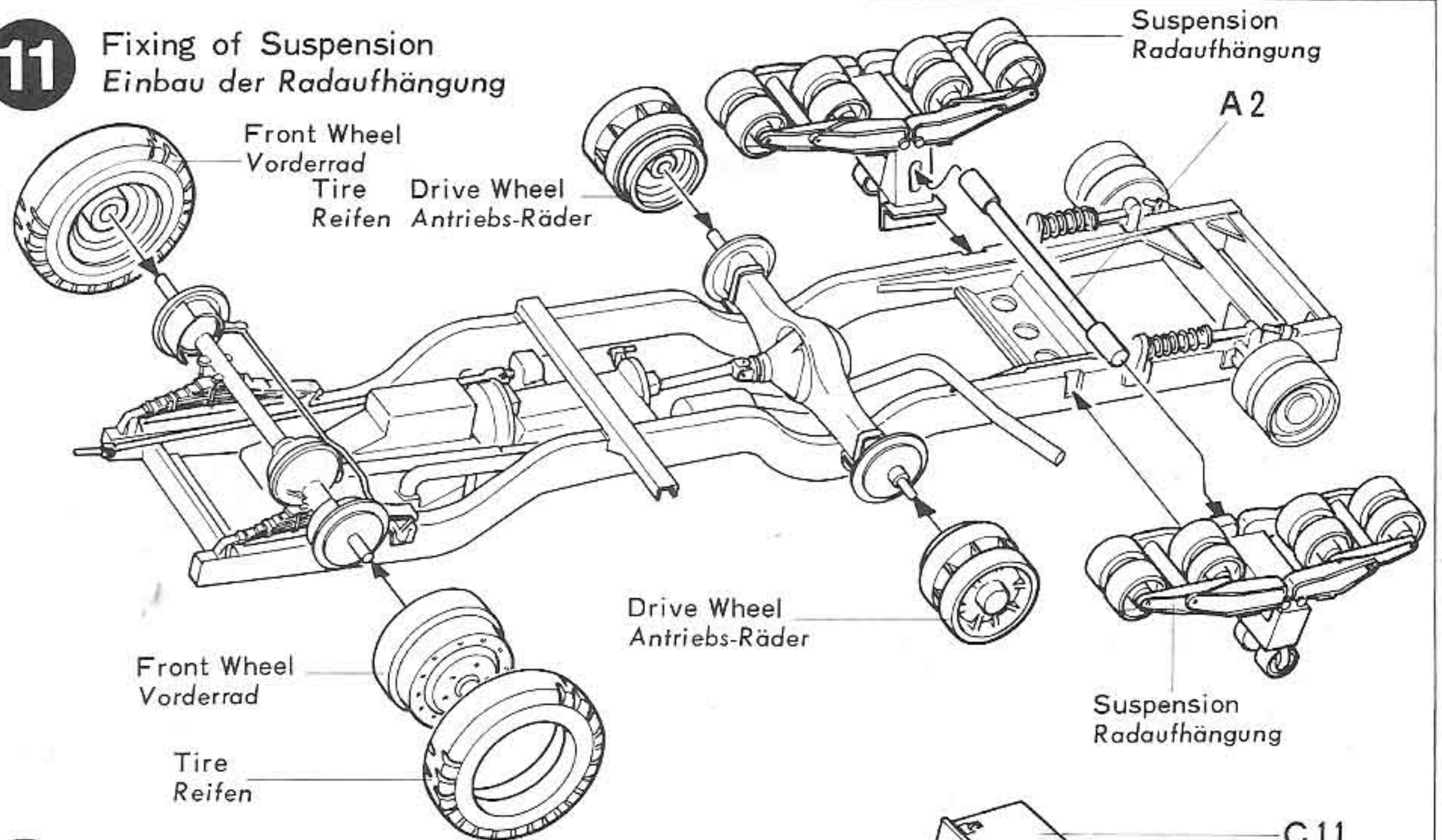

**12** Construction of Doors and Rear Panel  
Construction der Hinterfach

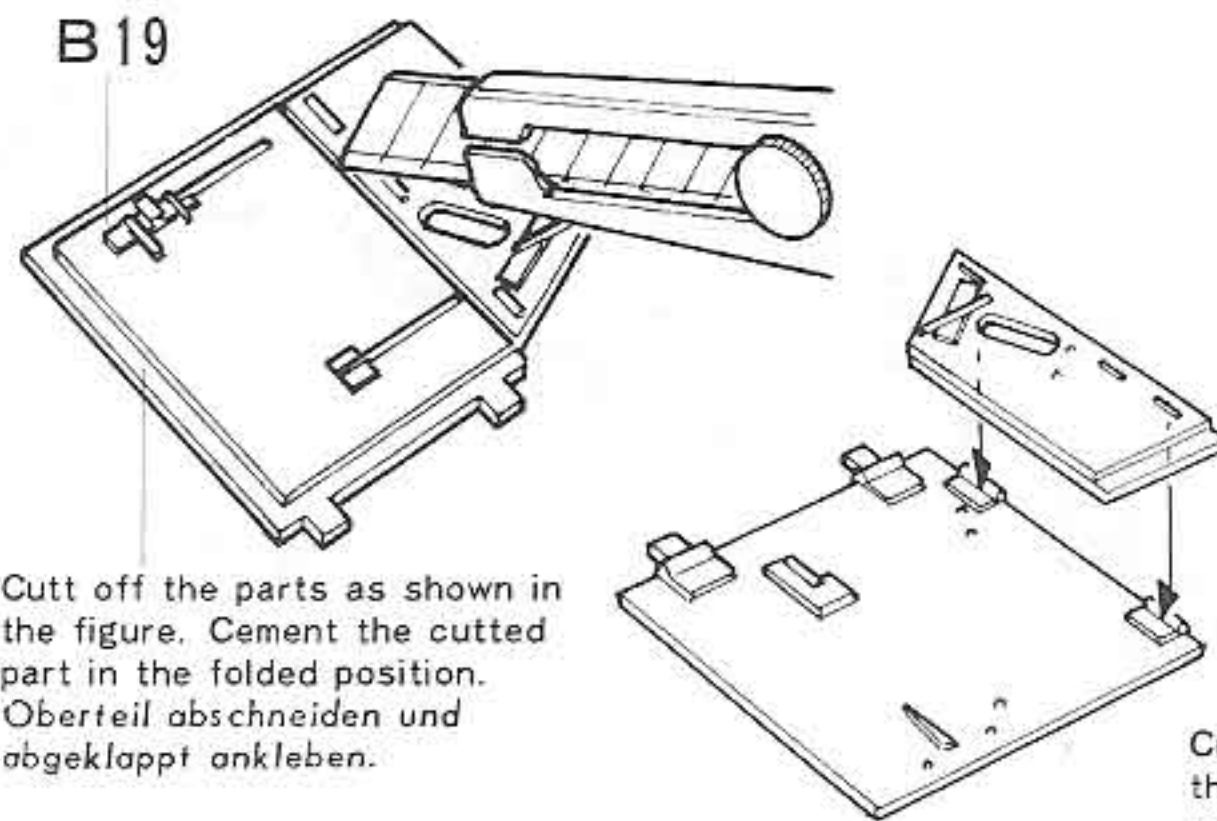

Cut off the parts as shown in the figure. Cement the cutted part in the folded position.  
Oberteil abschneiden und abgeklappt ankleben.

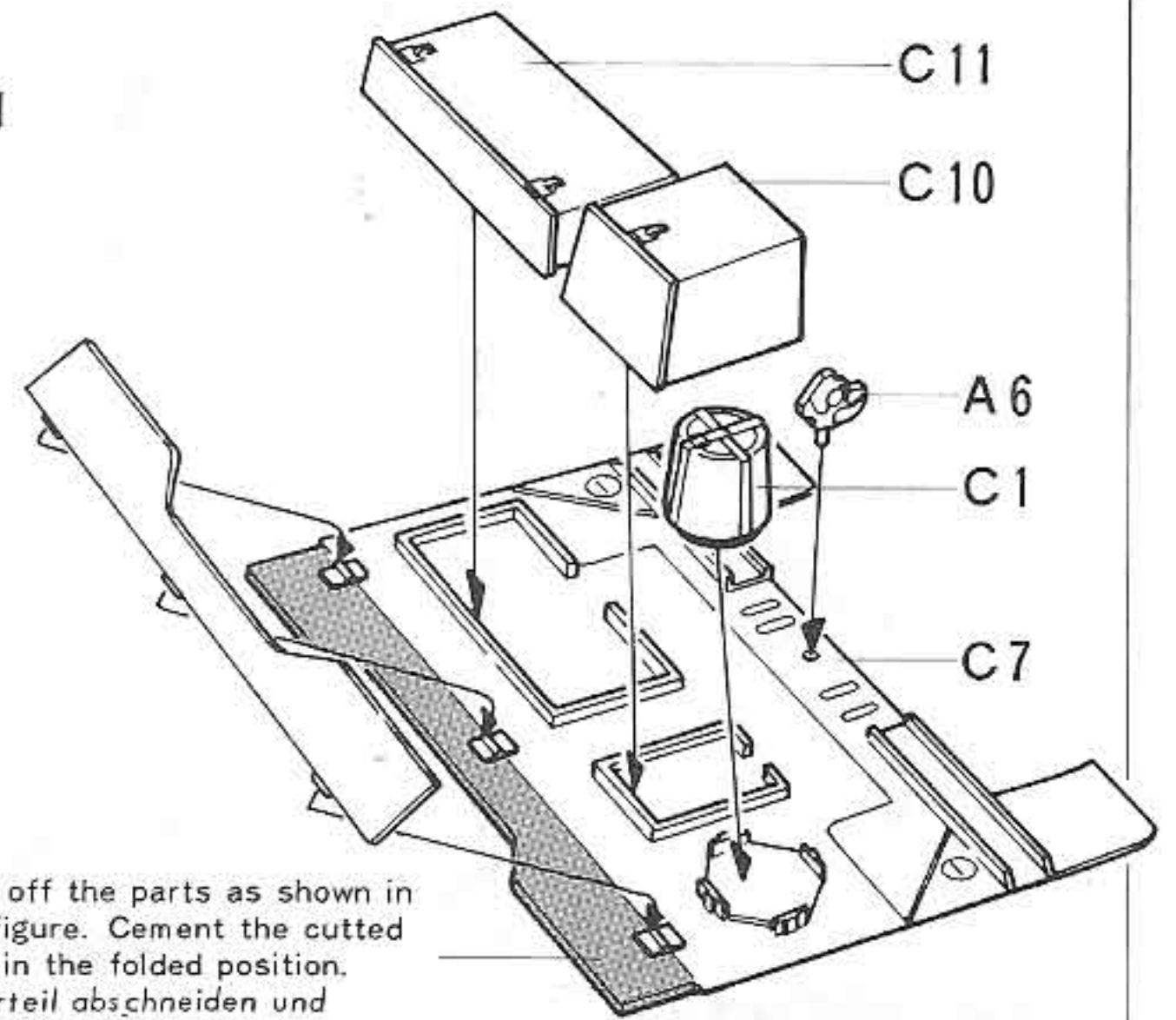

Cut off the parts as shown in the figure. Cement the cutted part in the folded position.  
Oberteil abschneiden und abgeklappt ankleben.

**13** Construction of Side Panel  
Bau der Seitenteile

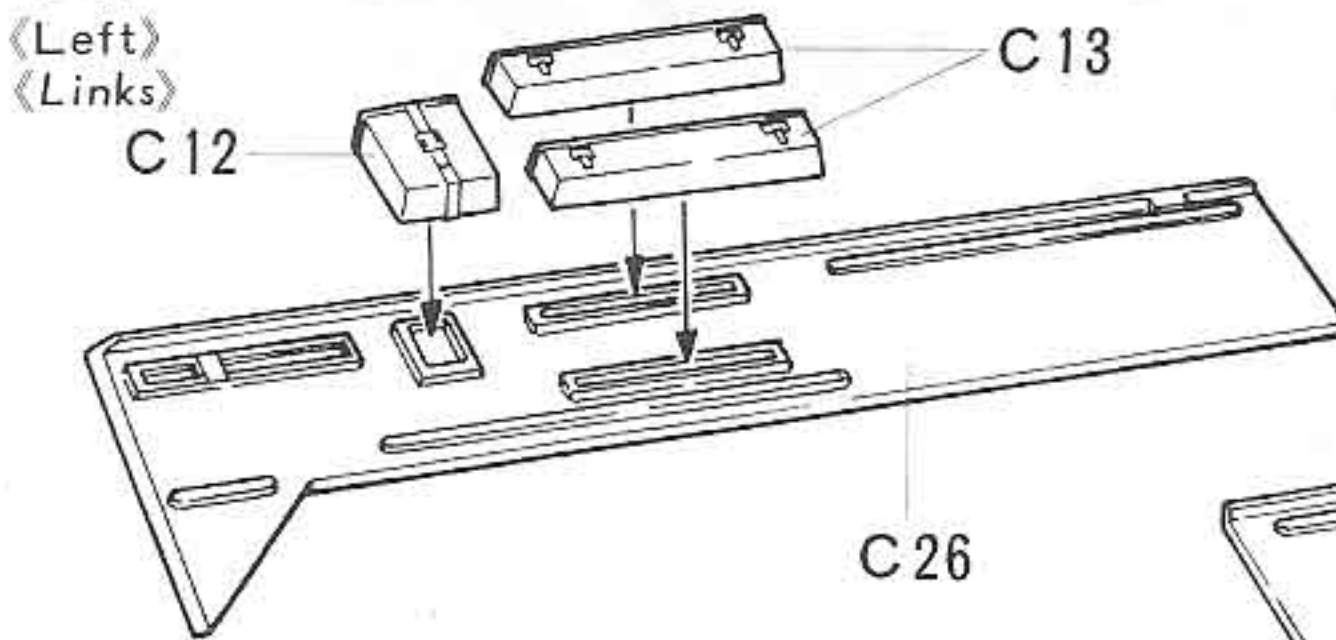

<Left>  
<Links>

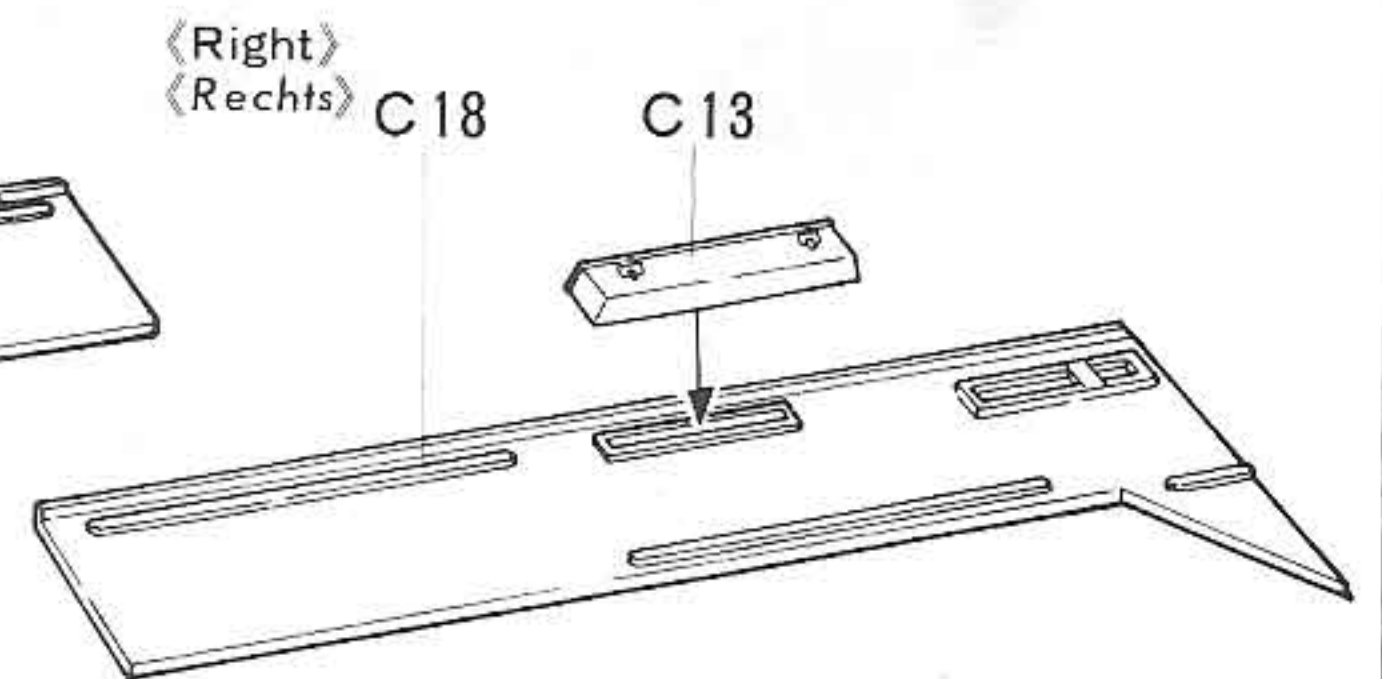

<Right>  
<Rechts>

**14** Construction of Cockpit  
Construction des Fahrersitz

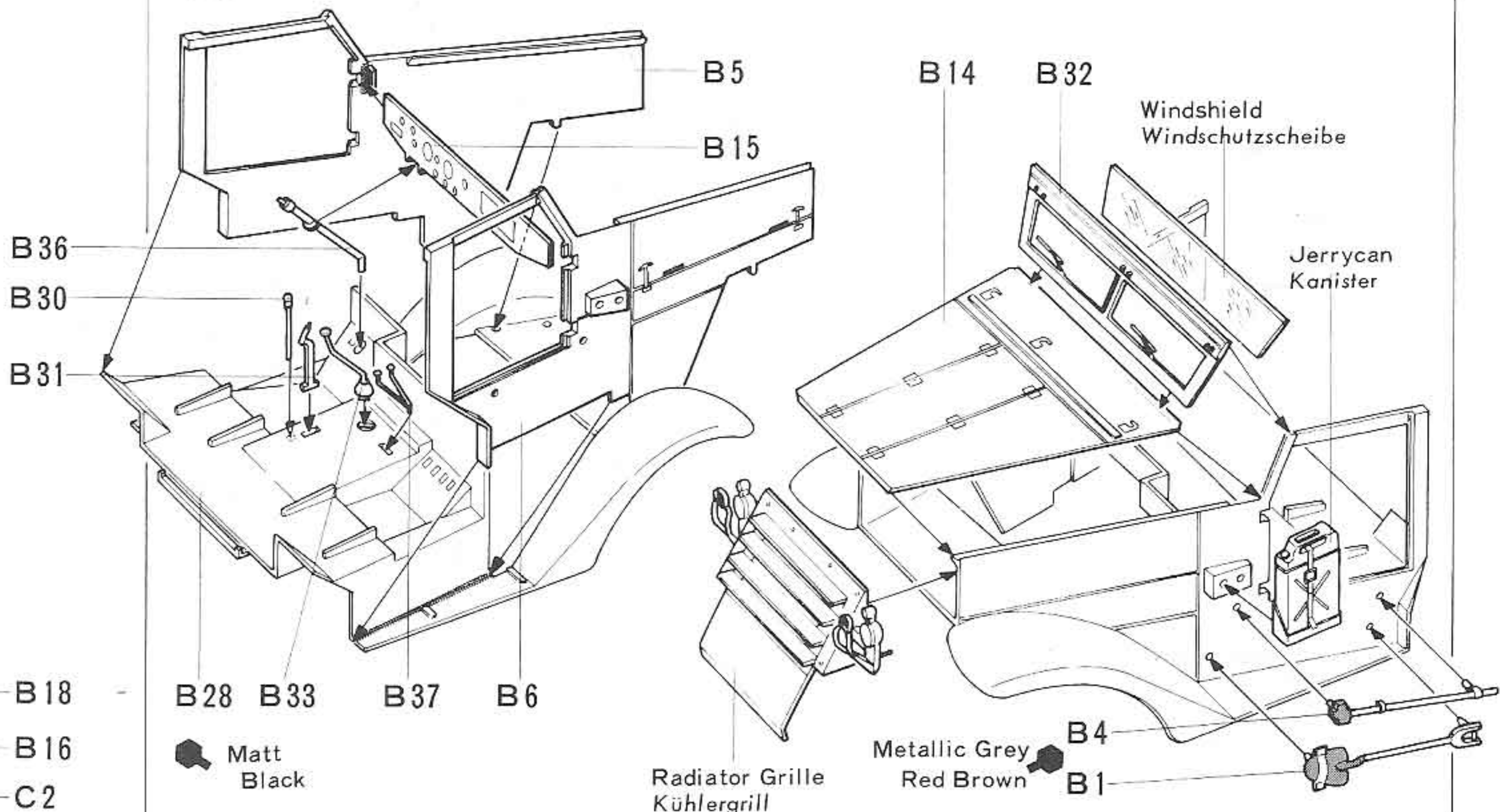

● Matt Black

● Metallic Grey  
● Red Brown



《Construction of Radio》  
《Radio》

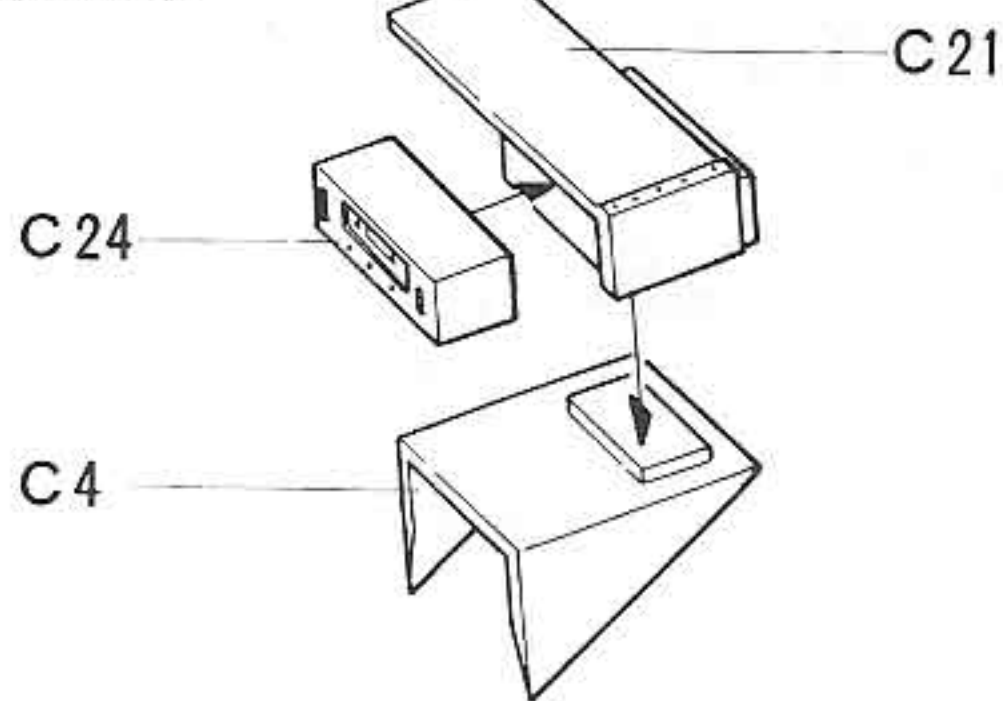

16 《Fixing of Body》  
《Einbau der Aufbauten》

Fixing each parts after cementing Body to Chassis. B29, C17, and C25 can be fixed either in open or closed position. If you prefer to closed position, B38 is unnecessary.

Zuerst Aufbau auf Chassis kleben, dann komplettieren, siehe Bild. B 29, C 17, C 25 kann offen oder geschlossen eingeklebt werden. B 38 nicht notwendig bei geschlossen.

(Seat A)  
(Sitz A)

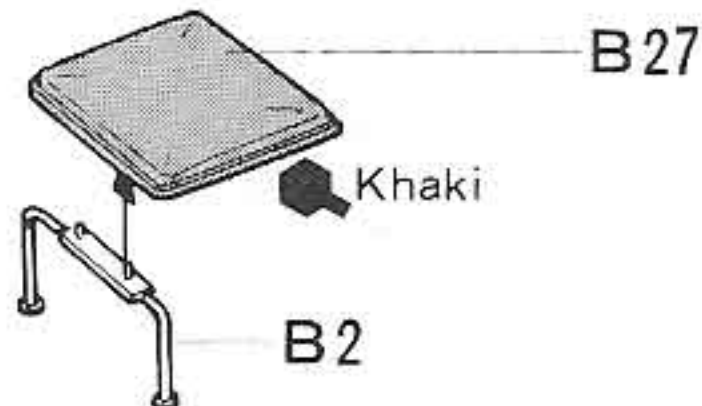

(Seat B)  
(Sitz B)

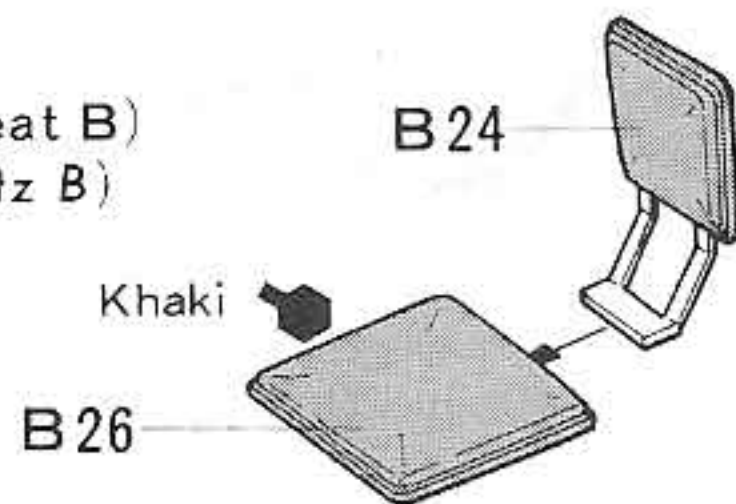

《Construction of Tracks》  
《Construction der Ketten》

Make 2 sets  
2 Satz

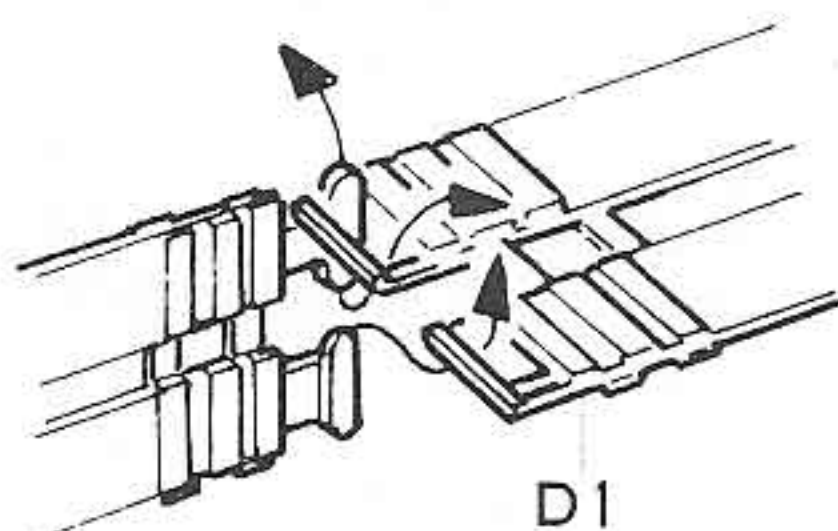

15 Construction of Rear Deck  
Bau des Fahrzeughecks

《Magazine Holder》  
《Magazin Halter》

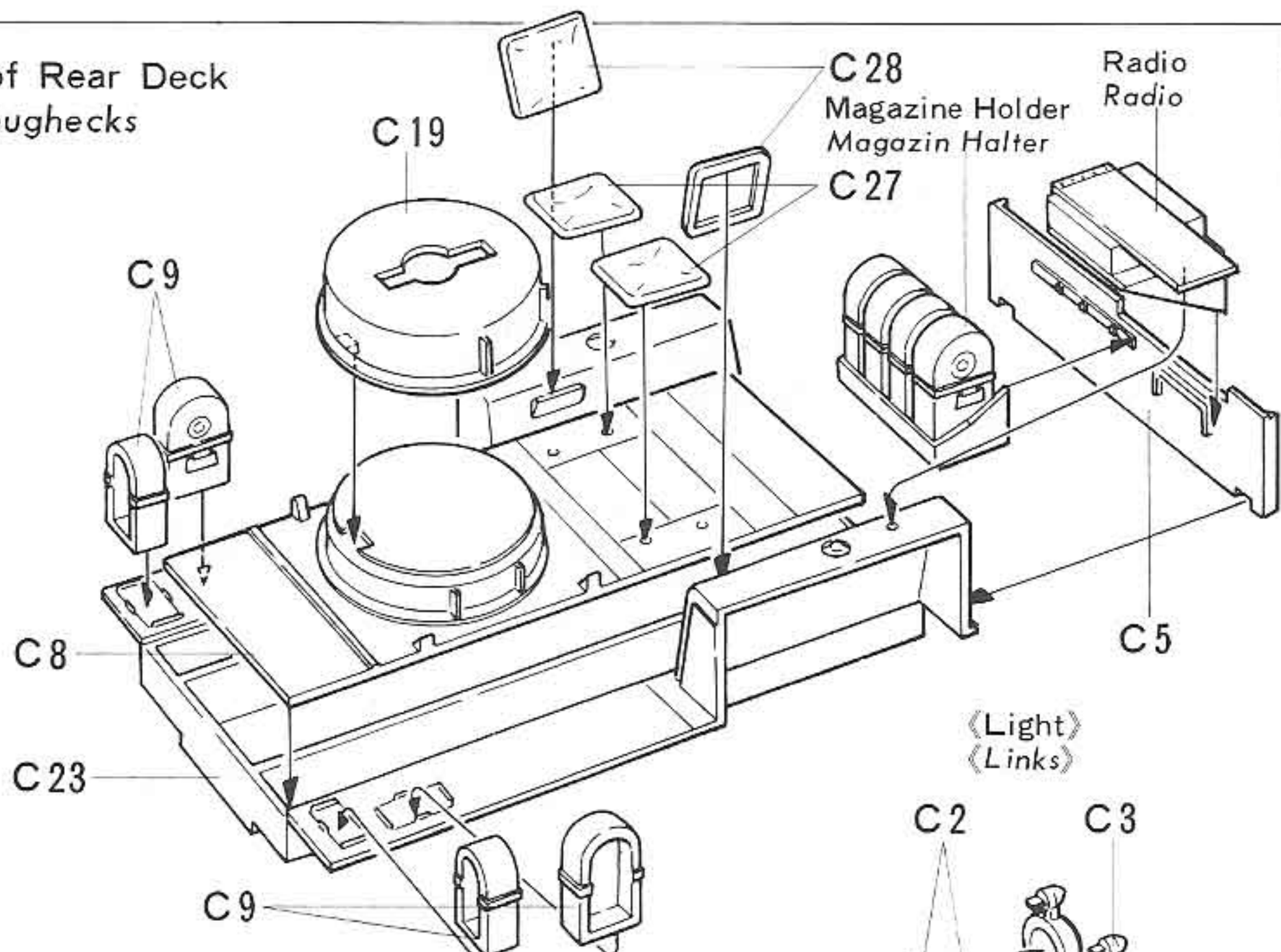
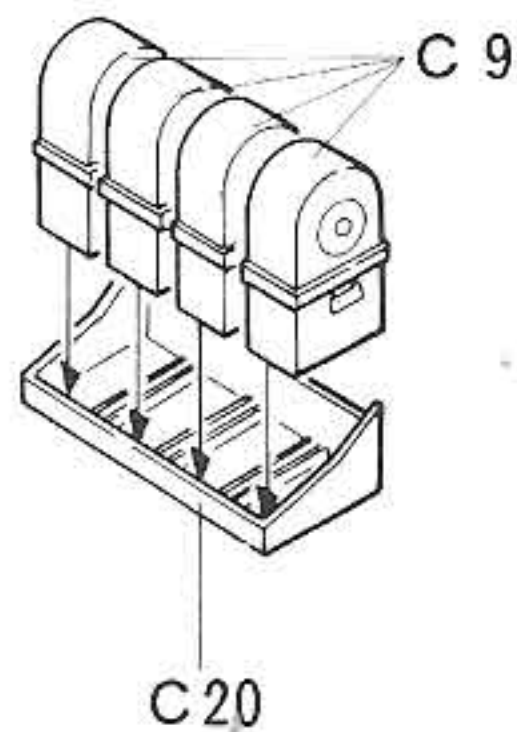

16 Construction of Body  
Fahrzeug - Aufbau

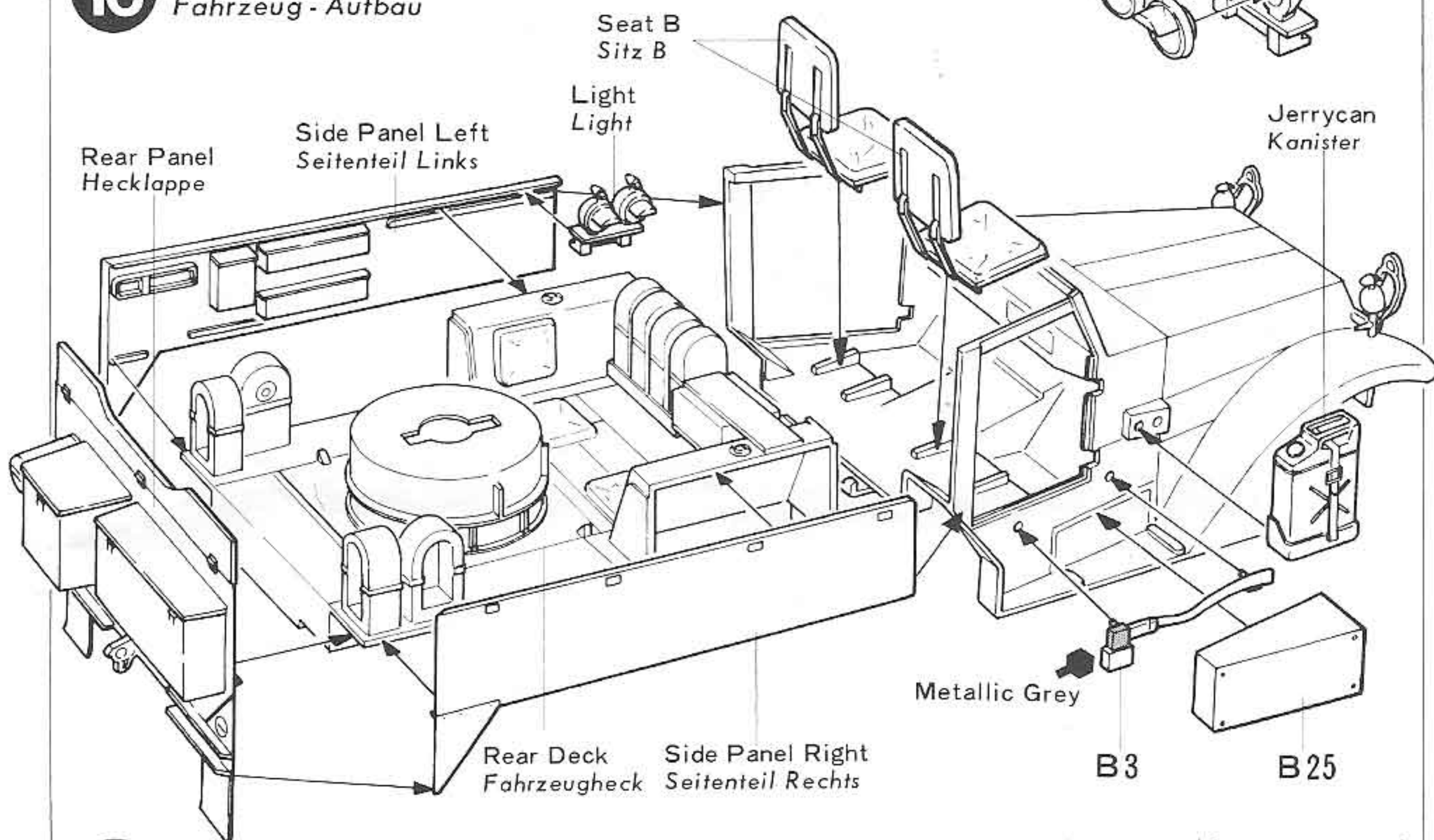

17 Fixing of Body  
Einbau der Aufbauten

B20  
(Closed Position)  
(Geschlossene Tür)

B29  
B38

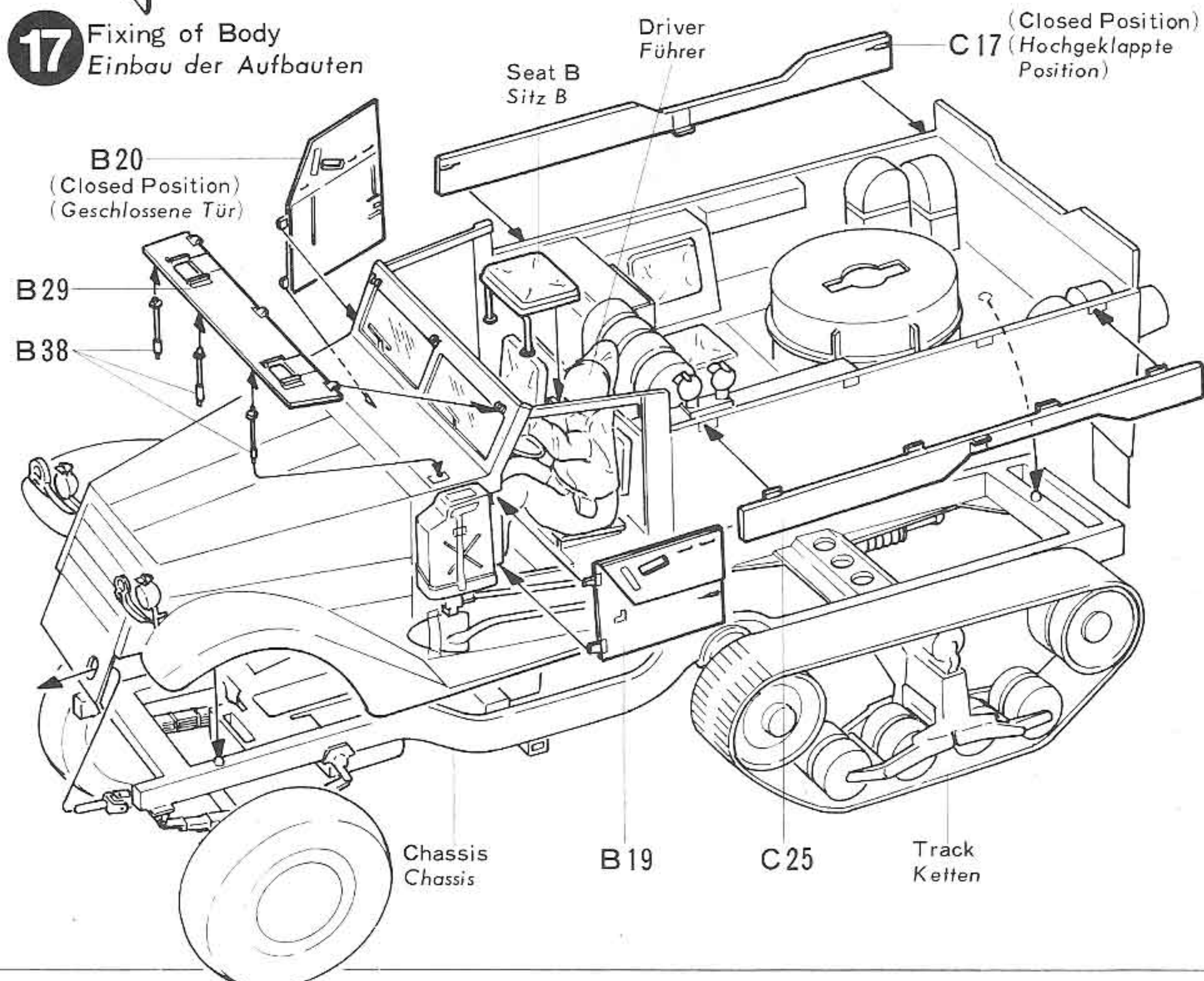

Like to detail your models?

Tamiya has a fine line of photo albums that will help you in the super detailing of your tank models or diorama construction. See them at your nearest Tamiya supply house, or order direct from the factory.



**18** (Bumper)  
(Stoßfänger)

Metallic Grey

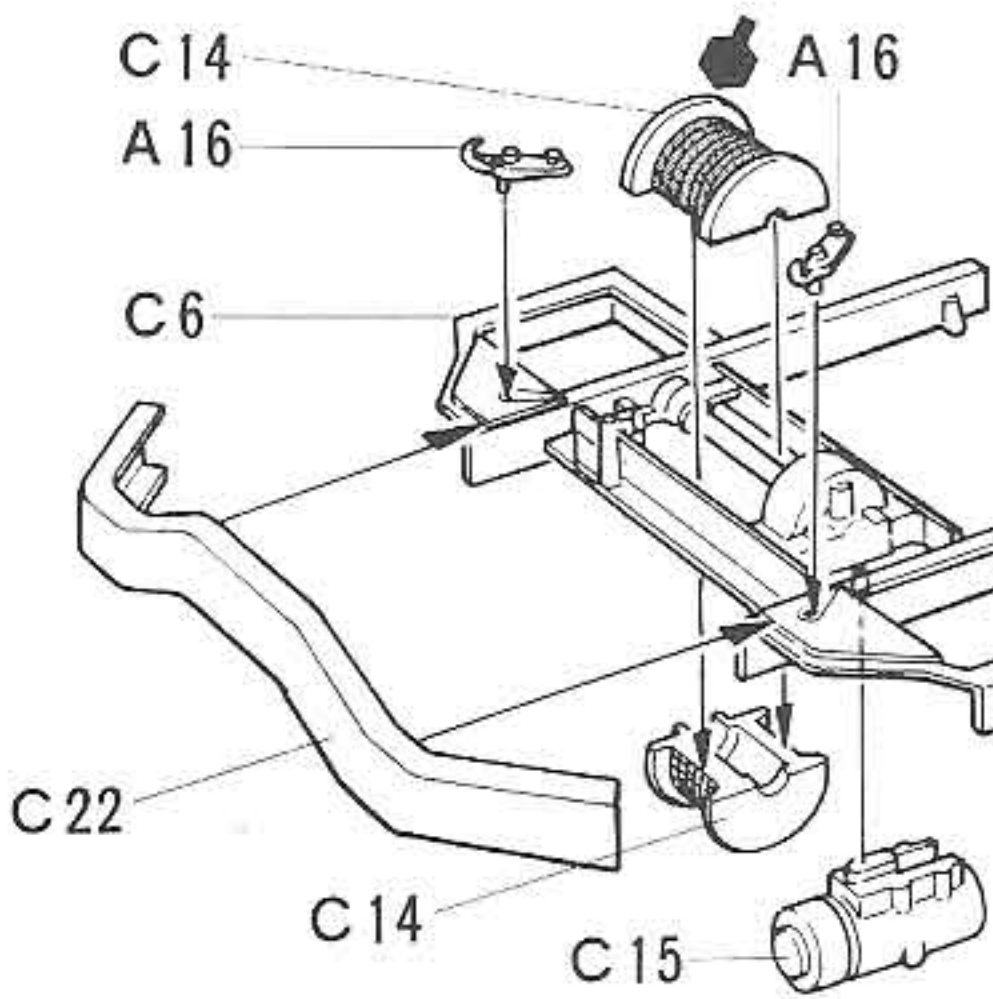

★A14 is designed to rotate. Do not cement.  
★A14 ist drehbar. Nicht kleben.

**18** Fixing of M.G. and Bumper  
Einbau der M.G. und Stoßfänger

★Fit in this position and turn  
Maschinengewehr  
★Turn in dieser Richtung einstecken  
und drehen.

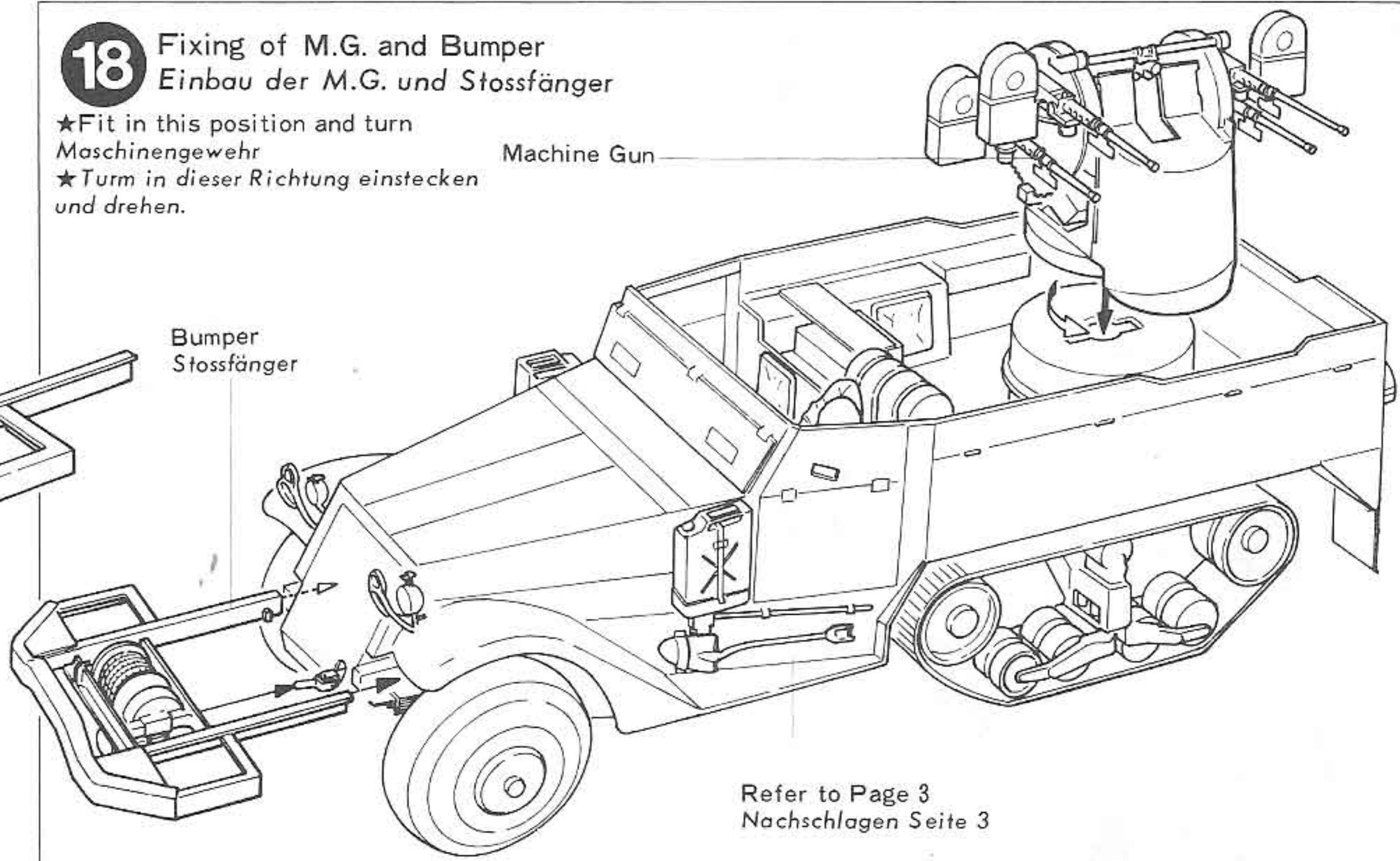

**PAINTING**  
&  
**APPLYING DECALS**

⟨Painting of the M16⟩

M16 Half track, like other military vehicles of the U.S. Army, was painted overall in Olive Drab.

★What we call "weathering" is a good way to lend additional realism to your military vehicles. It may be interesting to represent the following, for instance: dirt which stuck to the vehicle in a desert, swamp, etc.; and bullet marks made in actual fighting.

Wie alle US Militärfahrzeuge war der M 16 olivedrab gespritzt. "Verdrechte" Bemalung machen des Modell wirklich echt.

⟨Marking of M16⟩

M16 wore unit numbers and vehicle numbers as well as star marks symbolic of the U.S. Army.

**Tamiya Acrylic Paints**

Need precise colour matching? Try the new Tamiya acrylic paints. Engineered by modelers for modeler's use. The final cover for the finest models. Insist on Tamiya for perfect results.



**TAMIYA COLOR CATALOGUE**

The latest in cars, boats, tanks and ships. Motorized, radio controlled and museum quality models are all shown in full color in Tamiya's latest catalogue. At your nearest hobby supply house.

⟨Marking of M16⟩  
⟨Markierung des M16⟩  
Olive Drab

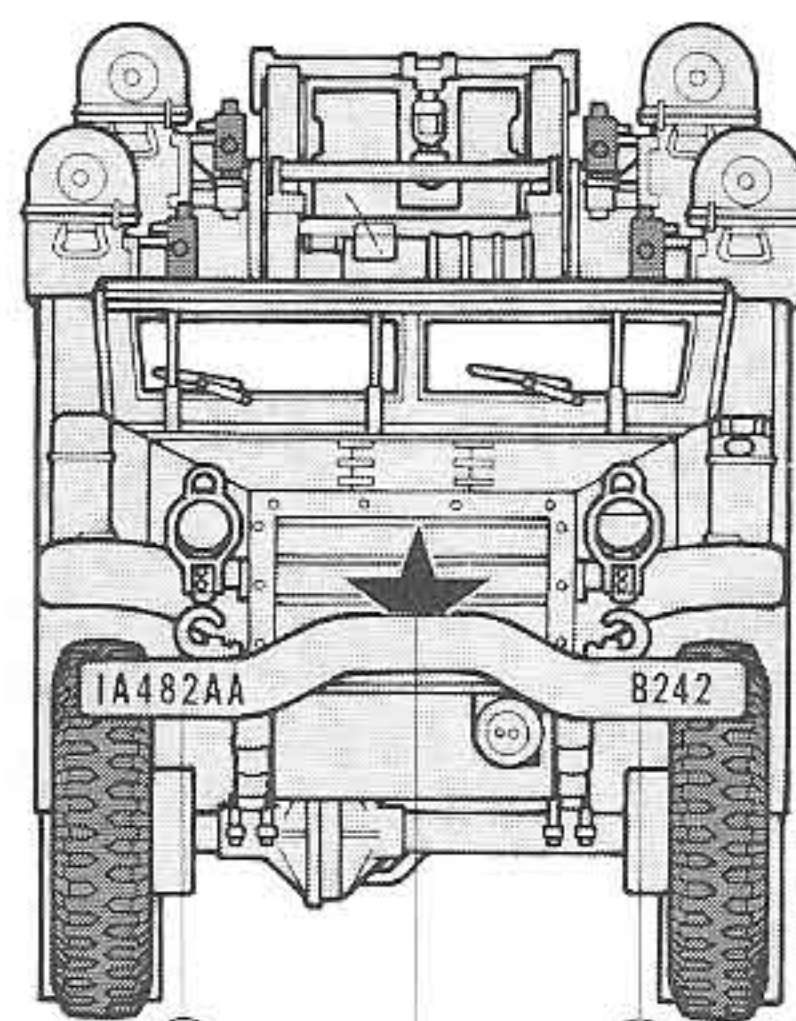
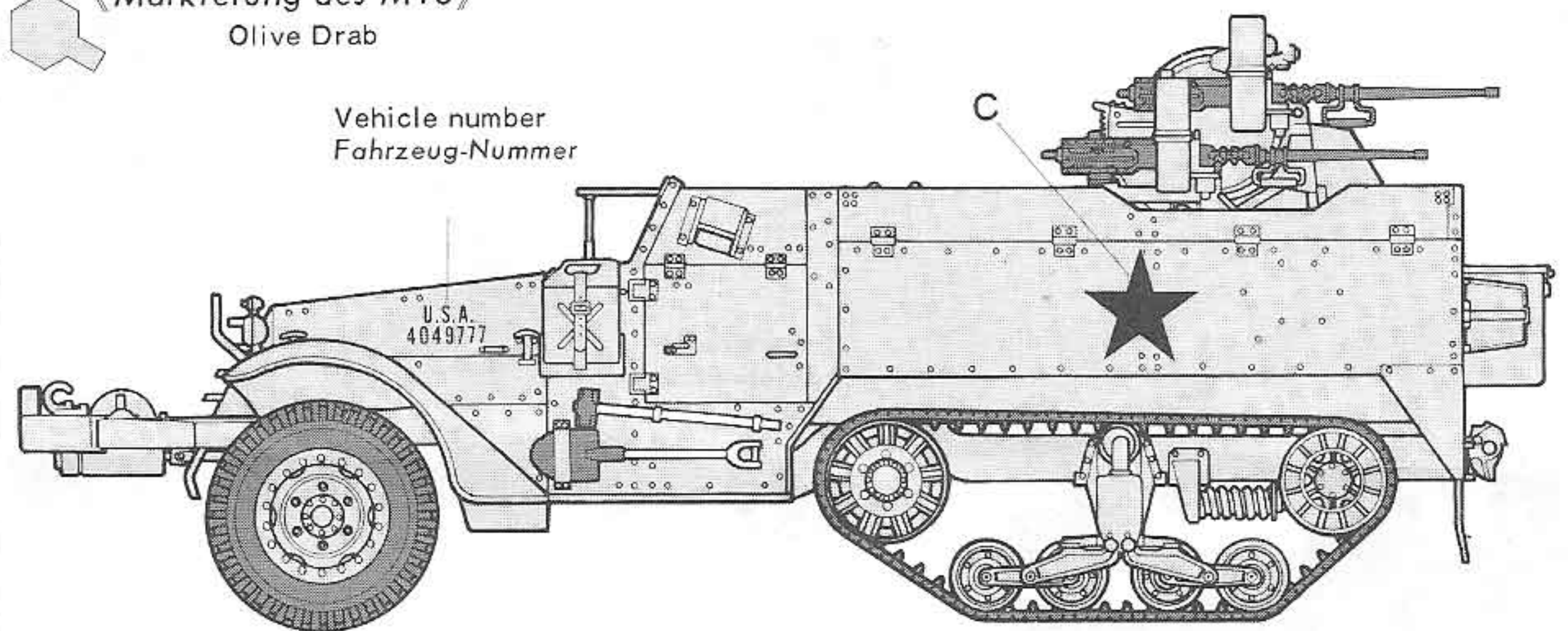

① M16 used after W.W.II  
M16 nach dem WW II

U.S.A. 4049777 — IA482AA — B242

② U.S.A. 4049777  
M16 used in W.W.II  
M16 im WW II

U.S.A. 4050337S — IΔ2AA — A132

③ M16 used in Korean War  
M16 in Korea

U.S.A. 4050337S — 8Δ50AA — B162

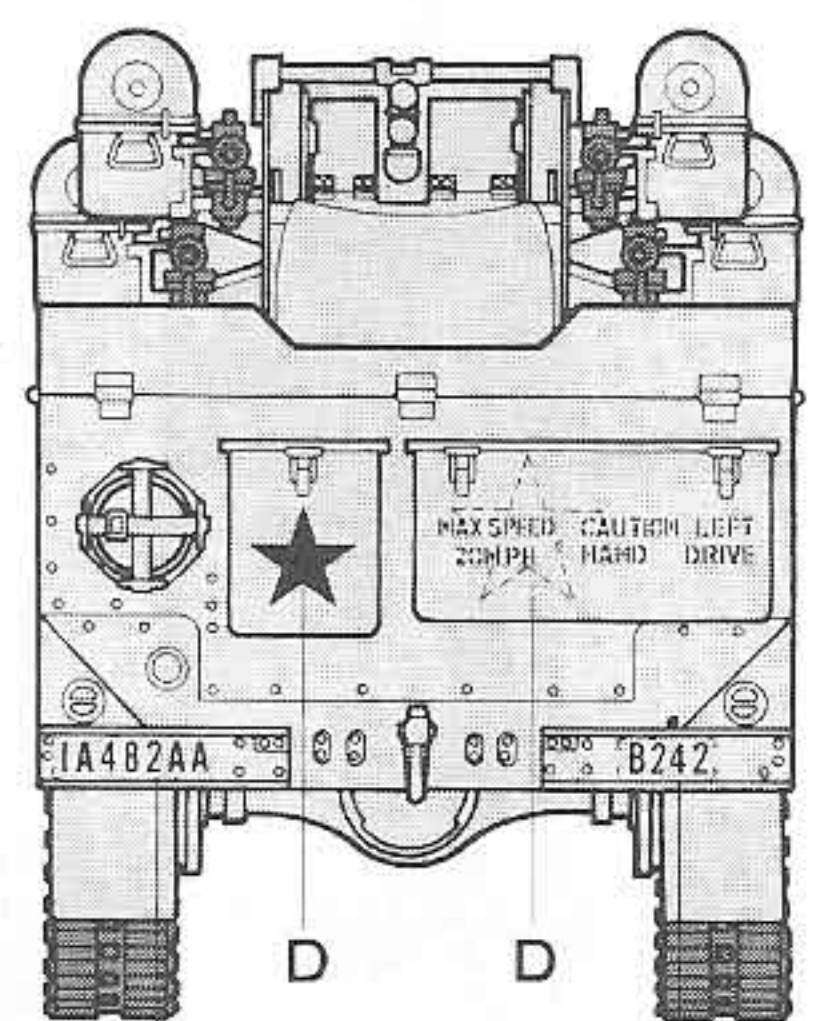

MAX SPEED 20MPH CAUTION LEFT HAND DRIVE

② Cut with dotted line  
Schneiden



③ Cut along the dotted lines as shown above.

An punktierter Linie ausschneiden.

A or E  
A oder E

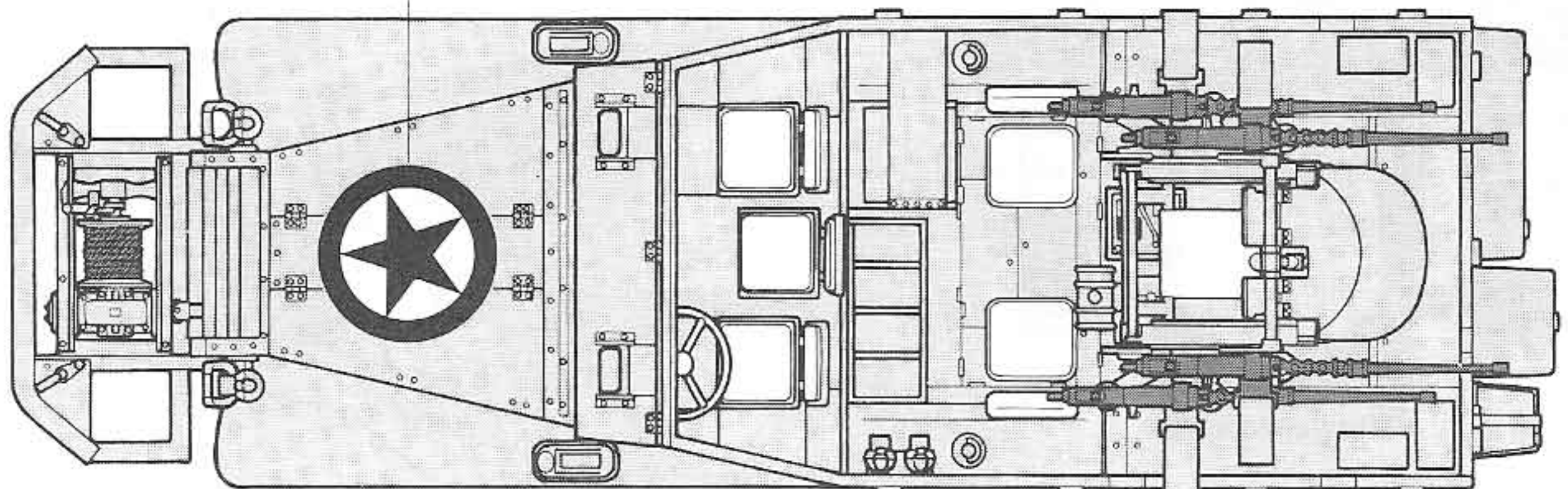



# PARTS

## A PARTS

- |                               |                     |
|-------------------------------|---------------------|
| 1. Frame                      | 2. Cross Tube       |
| 3. Rear Axle                  | 4. Rear Shaft       |
| 5. Spring Arm                 | 6. Hooks            |
| 7. Rear Axle Parts            |                     |
| 8. Rear Brake Covers          |                     |
| 9. Suspension B               | 10. Top Rollers A   |
| 11. Top Rollers B             | 12. Front Shaft     |
| 13. Rear Brake Drums          |                     |
| 14. Transfer Parts            | 15. Suspension Part |
| 16. Front Hooks               | 17. Muffler         |
| 18. Battery Frame             | 19. Idler Wheels A  |
| 20. Drive Wheels A            | 21. Drive Wheels B  |
| 22. Idler Wheels B            | 23. Front Wheels    |
| 24. Idler Wheel Shaft (Right) |                     |
| 25. Discs                     |                     |
| 26. Idler Wheel Shaft (Left)  |                     |
| 27. Adjust Rod (Left)         |                     |
| 28. Adjust Rod (Right)        |                     |
| 29. Road Wheels B             | 30. Knackle (Left)  |
| 31. Knackle (Right)           | 32. Front Axle B    |
| 33. Front Axle A              |                     |
| 34. Front Brake Drum          | 35. Tie Rod         |
| 36. Leaf Spring (Left)        |                     |
| 37. Leaf Spring (Right)       |                     |
| 38. Front Brake Cover         |                     |
| 39. Road Wheels A             |                     |

## B PARTS

- |                                     |                       |
|-------------------------------------|-----------------------|
| 1. Shovel                           | 2. Seat Support       |
| 3. Ax                               | 4. Hammer             |
| 5. Front Side Panel (Left)          |                       |
| 6. Front Side Panel (Right)         |                       |
| 7. Spare Tank B                     | 8. Spare Tanks A      |
| 9. Unnecessary                      | 10. Unnecessary       |
| 11. Unnecessary                     | 12. Unnecessary       |
| 13. Driver's Feet                   | 14. Bonnet            |
| 15. Instrumentation Panel           |                       |
| 16. Headlight B                     |                       |
| 17. Headlight A (Left)              |                       |
| 18. Headlight A (Right)             |                       |
| 19. Door (Left)                     | 20. Door (Right)      |
| 21. Radiator Grille A               | 22. Radiator Grille B |
| 23. Headlight Guards                | 24. Seat Back Rest    |
| 25. Battery Case                    | 26. Seat A            |
| 27. Seat B                          | 28. Front Fender      |
| 29. Windscreen Armour Plate         |                       |
| 30. Lever B                         | 31. Side Brake Lever  |
| 32. Windscreen Frame                |                       |
| 33. Lever A                         | 34. Handle            |
| 35. Headlight C                     |                       |
| 36. Steering Wheel Shaft            |                       |
| 37. Twin Lever                      |                       |
| 38. Windscreen Armour Plate Support |                       |

## C PARTS

- |                           |                    |
|---------------------------|--------------------|
| 1. Bucket                 |                    |
| 2. Air defence Light B    |                    |
| 3. Air defence Light A    |                    |
| 4. Radio Stay             | 5. Bulkhead        |
| 6. Winch                  | 7. Rear Panel      |
| 8. Floor Panel B          | 9. Magazine Case B |
| 10. Box B                 | 11. Box A          |
| 12. Box C                 | 13. Box D          |
| 14. Winch Roller          | 15. Gear Box       |
| 16. Shaft for Winch       |                    |
| 17. Side Panel R (Lower)  |                    |
| 18. Side Panel R (Upper)  |                    |
| 19. Rotary Plate A        |                    |
| 20. Ammunition Box Holder |                    |
| 21. Radio                 | 22. Bumper         |
| 23. Floor Panel           | 24. Radio          |
| 25. Side Panel L (Lower)  |                    |
| 26. Side Panel L (Upper)  |                    |
| 27. Rear Seat             | 28. Rear Seat Back |

## D PARTS

- |                 |                 |
|-----------------|-----------------|
| 1. Track        | 2. Wheel Bush B |
| 3. Wheel Bush A | 4. Front Tyres  |

## E PARTS

- |                         |                      |
|-------------------------|----------------------|
| 1. Rotary Plate B       | 2. Transceiver B     |
| 3. Transceiver C        | 4. Transceiver A     |
| 5. M1 Carbine           | 6. Driver Body       |
| 7. Driver Hand R        | 8. Driver Hand L     |
| 9. Shoulder Bag         | 10. Bag              |
| 11. Gunner Hand L       | 12. Gunner Hand R    |
| 13. Gunner Body         | 14. Gunner Leg       |
| 15. Operator Hand L     | 16. Operator Hand R  |
| 17. Operator Body       | 18. Operator Leg R   |
| 19. Operator Leg L      | 20. Tommy Gun        |
| 21. Bayonets            | 22. Shovel           |
| 23. Blanket A           | 24. Blanket B        |
| 25. Helmet              | 26. Canteen          |
| 27. Ammunition Box A, R |                      |
| 28. Ammunition Box A, L |                      |
| 29. M.G. Base A, R      | 30. M.G. Base A, L   |
| 31. Rotary Plate C      | 32. Armour Plate     |
| 33. Sheet               |                      |
| 34. Firing Switch Box   |                      |
| 35. Handle              | 36. Pedestal Frame L |
| 37. Pedestal Frame L    | 38. Fuel Tank        |
| 39. Engine              | 40. Battery A        |
| 41. Battery B           | 42. M.G. Mount L     |
| 43. M.G. Mount R        | 44. Sight            |
| 45. Sheet roller        | 46. Shaft            |
| 47. Sight Stay          | 48. 12.7mm M.G. L    |
| 49. 12.7mm M.G. R       | 50. M.G. Mount C     |
| 51. M.G. Mount B, R     | 52. M.G. Mount B, L  |

## A PARTS

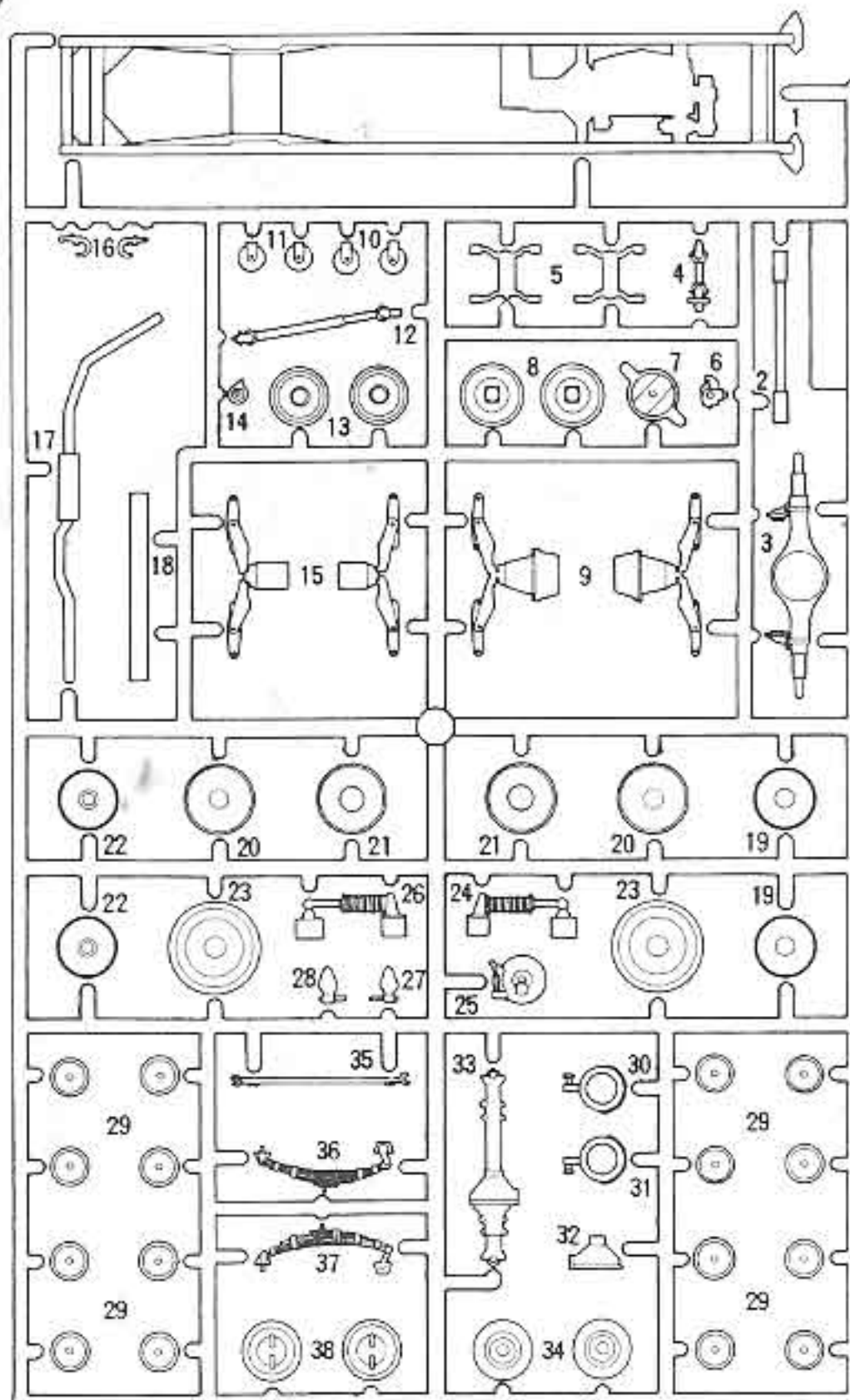

## B PARTS

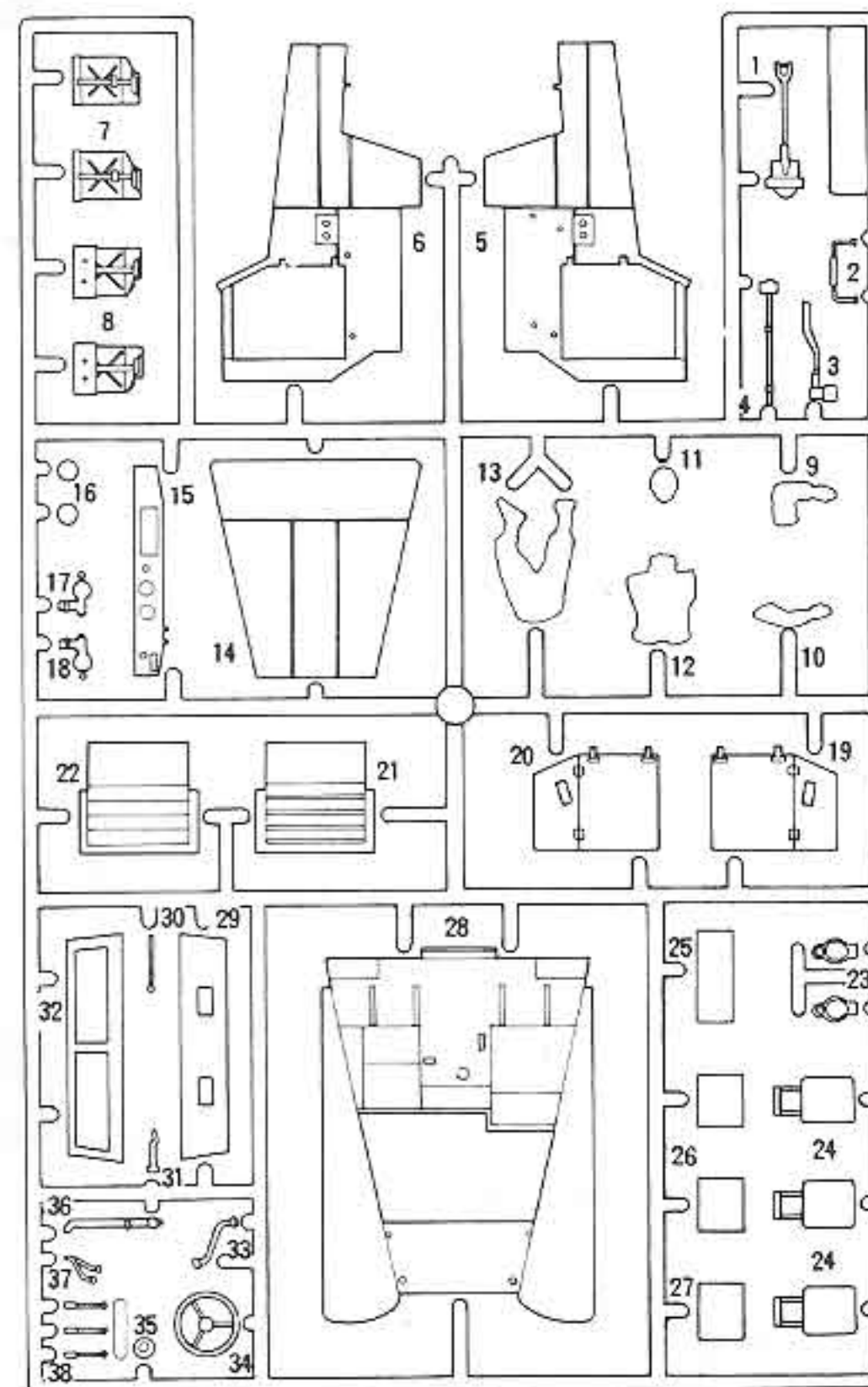

## C PARTS

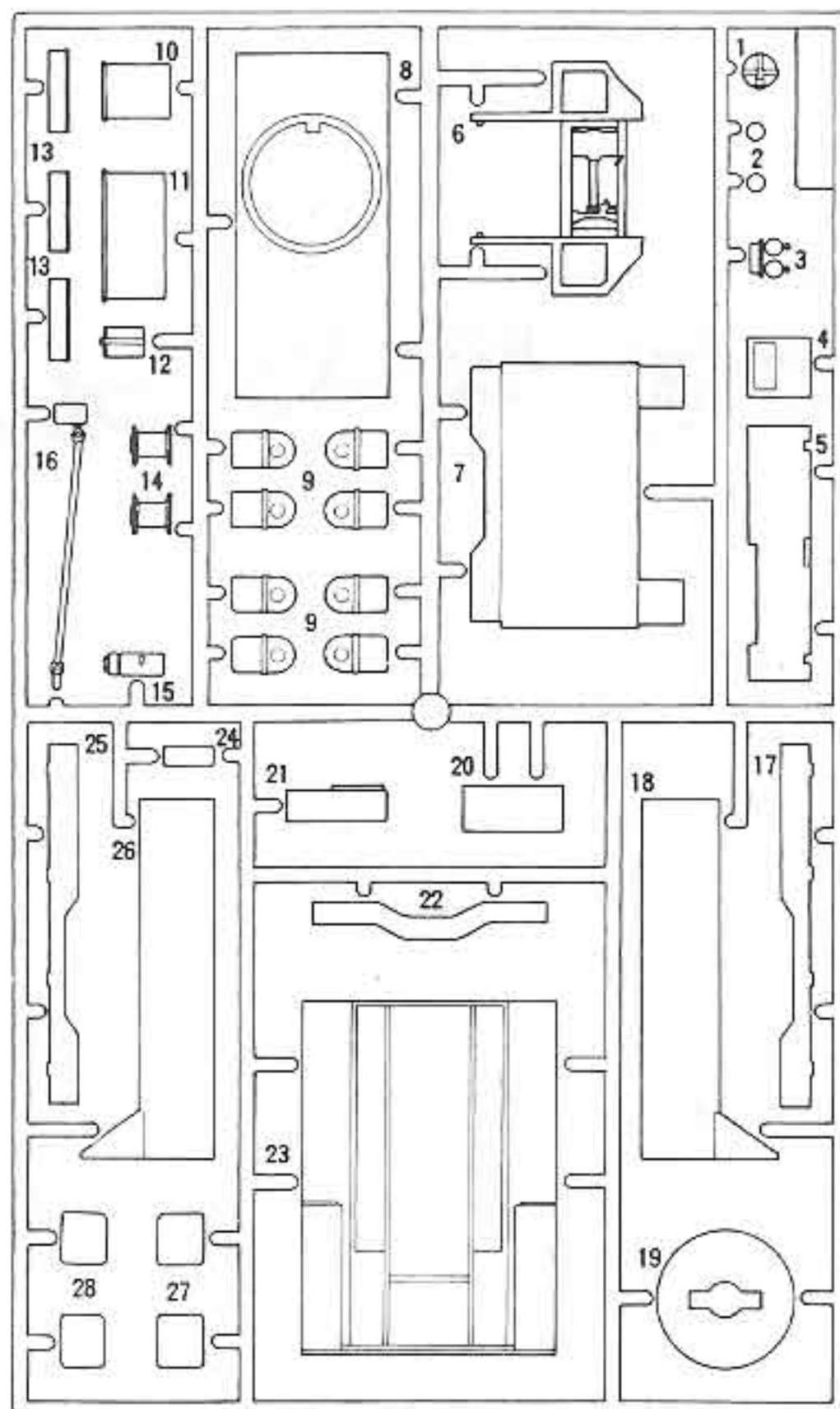

## E PARTS

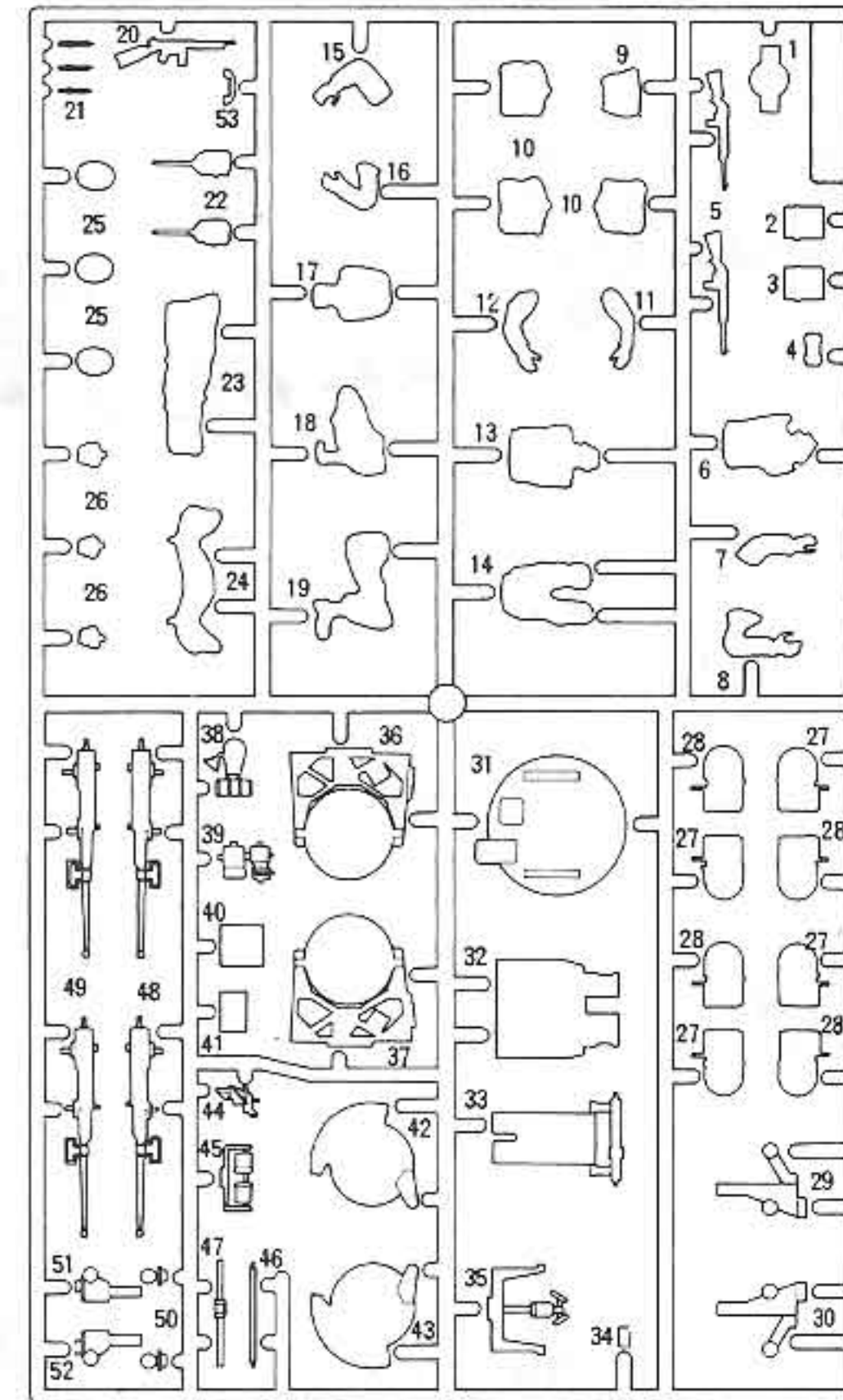

## D PARTS

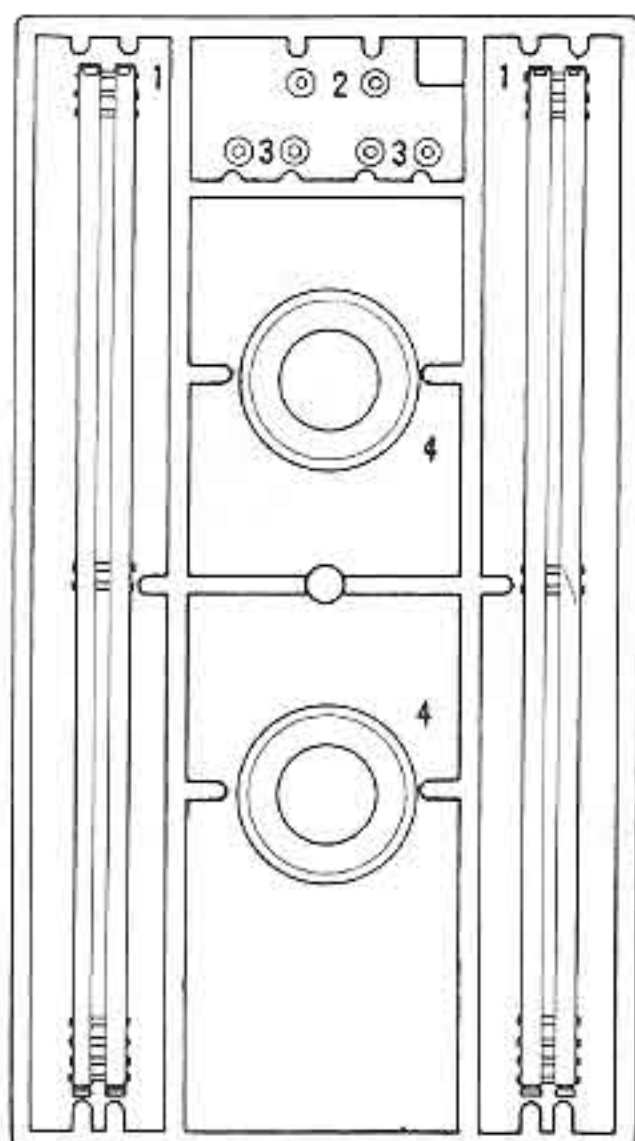

## FRONT SCREEN

