

1/35 SCALE
5078
History Miniature Series

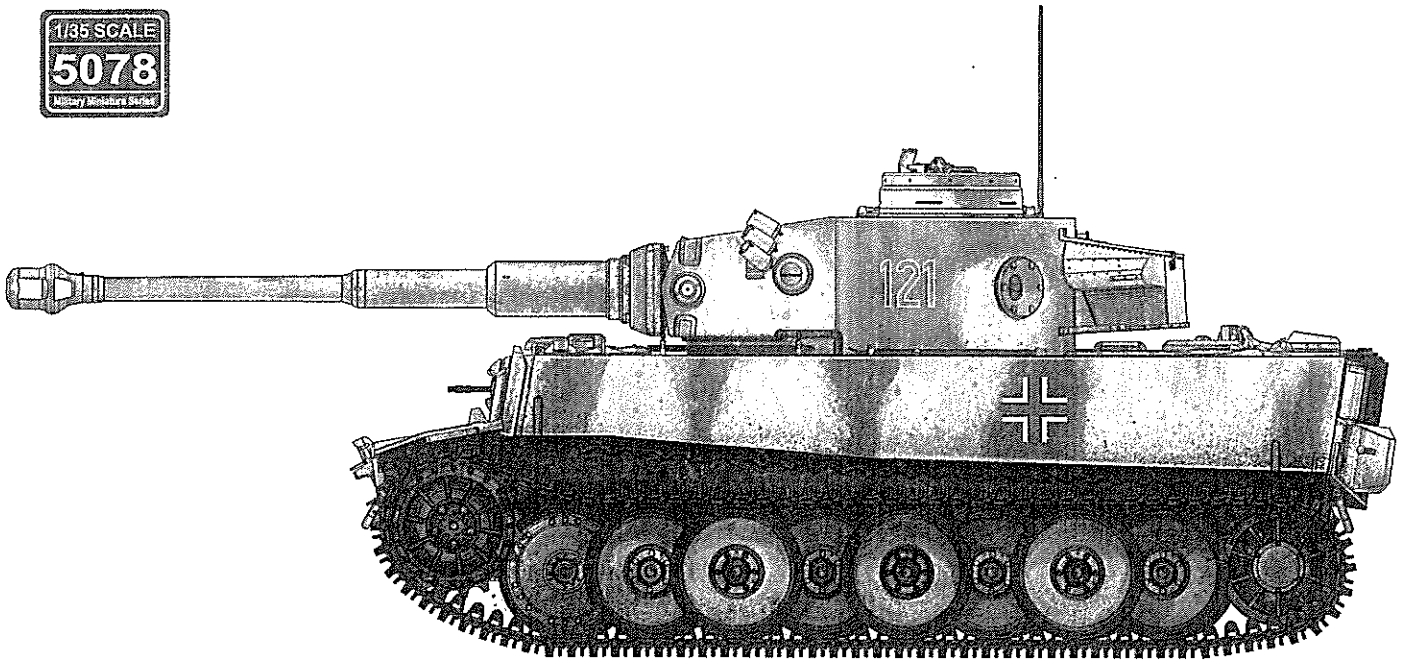

RFM
RYEFIELD MODEL®

Sd.Kfz.181

TIGER I INITIAL PRODUCTION

No.121 SpzAbt 502 Leningrad 1943

ASSEMBLY ICONS



OPTIONAL
选择



CEMENT
膠水



DO NOT CEMENT
不使用膠水



INSTANT CEMENT
瞬間接著劑



BEND
彎折



MAKE 2
製作2組



OPEN HOLE
鑽孔



REMOVE
切除



BE CAREFUL
注意



APPLY DECAL
貼上水貼紙

CAUTION!

Read carefully and fully understand the instructions before commencing assembly.
Supervising adult should also read the instructions if a child assembles the model.
When you used glue or paint, do not use near a naked flame, and use in a well-ventilated room.
When assembling this kit, tools including knives are used. Extra care should be taken to avoid personal injury.
Read and follow the instructions supplied with paints and/ or cement. Use plastic cement and paints only.
Keep out of reach of small children. Children must not be allowed to suck any part, or pull vinyl bag over the head.

在裝配前仔細閱讀說明並完全理解。小孩裝配時需成人看護且需仔細閱讀說明。
使用膠水和油漆時，應遠離火源並打開窗戶保持空氣流通。
製作時請格外注意工具刀和零件的鋒利尖銳部分，避免對身體造成傷害。
在使用膠水和油漆前仔細閱讀注意事項，按照說明正確使用膠水和油漆。
請將本品放在兒童接觸不到的地方，套件中的塑膠包裝袋會對兒童造成窒息的危險。

A x 1

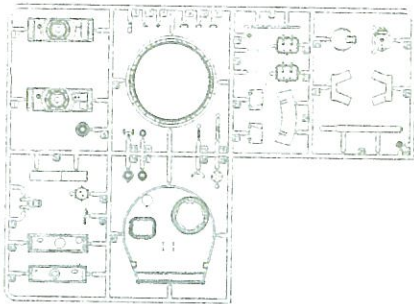

G x 1

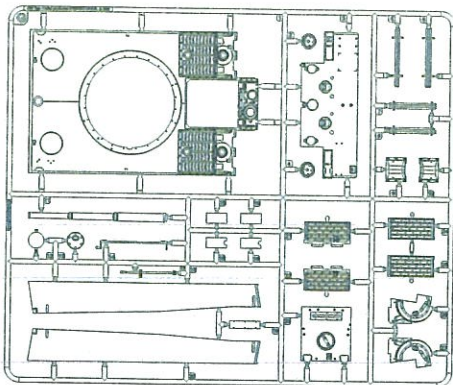

D x 2

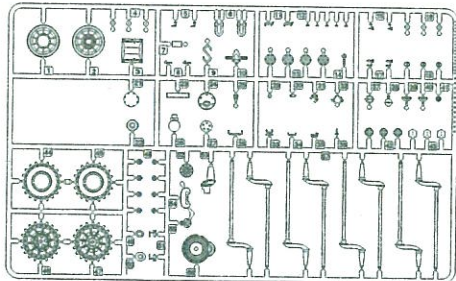

V x 4

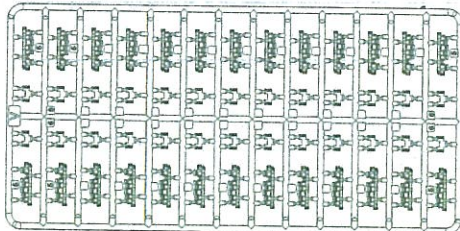

O x 1

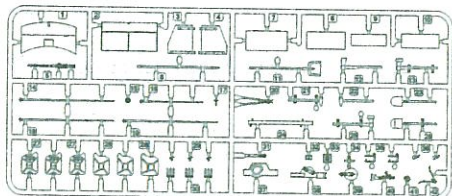

Cable 450mm



Cable 450mm



B x 1

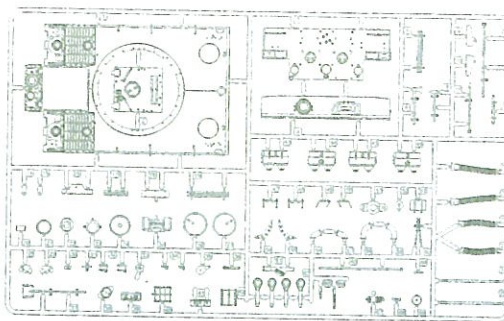

J x 1

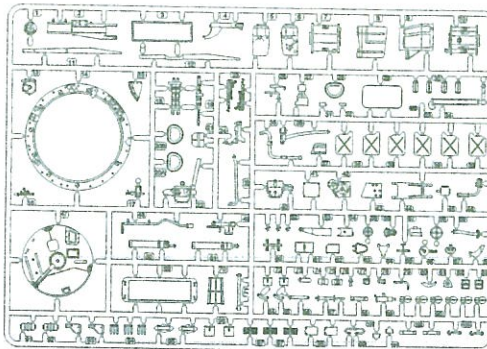

W x 1

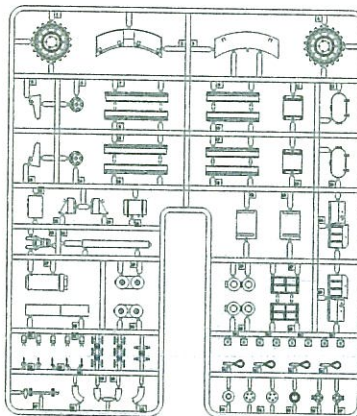

S x 1

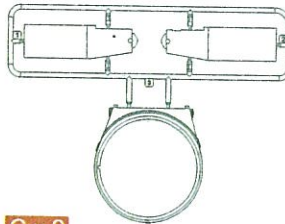

C x 2

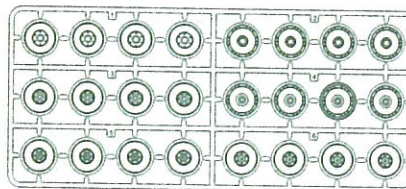

Cupola



T x 1



PA x 1



L x 18

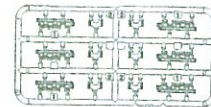

Lower hull x 1

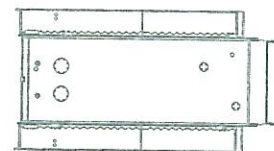

Q x 1

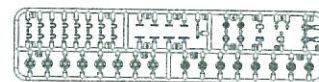

PC x 1

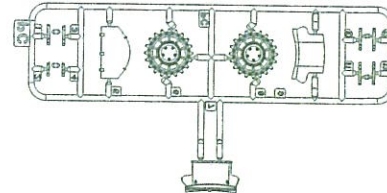

Decal



Y x 1

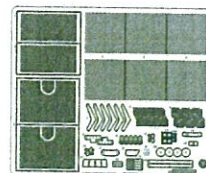

1

Q1(Q1)x8

D57(D57)x8

D6(D6)

G26(G27)

Workable Torsion Bars

2

0.9mm

G3

Q11

Y24

B42

B69

Q12

W24

W21

W24

3

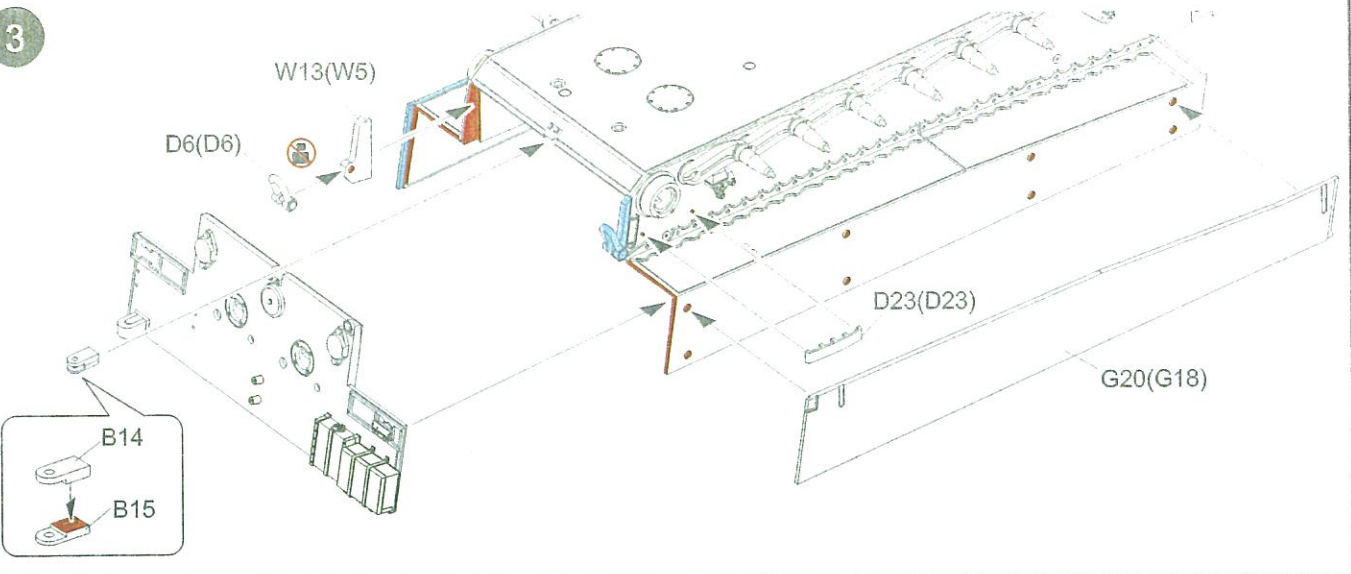

4

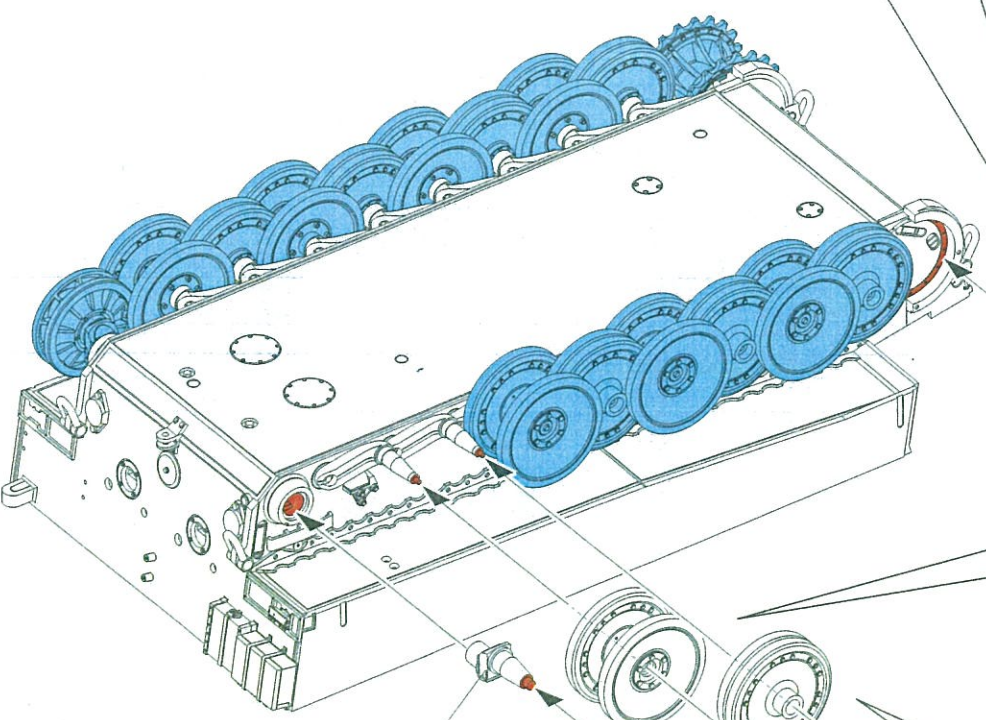
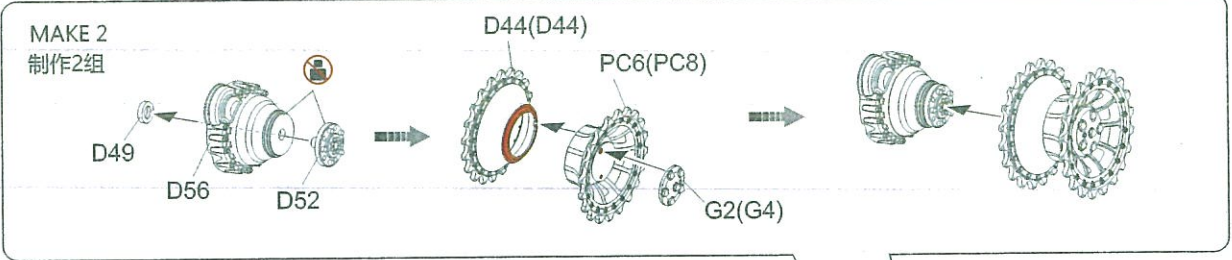

Use the cement for wheels
after assemble the track links.
装配好履带后再使用胶水
粘接主动轮

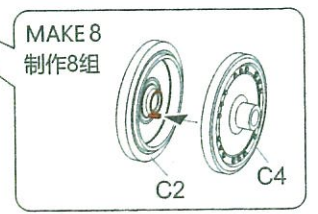
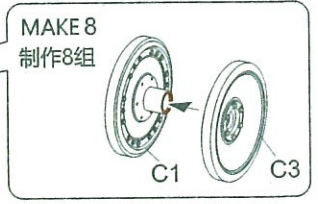

Use the cement for D53 after
assemble the track links.
装配好履带后再使用胶水粘接D53

5

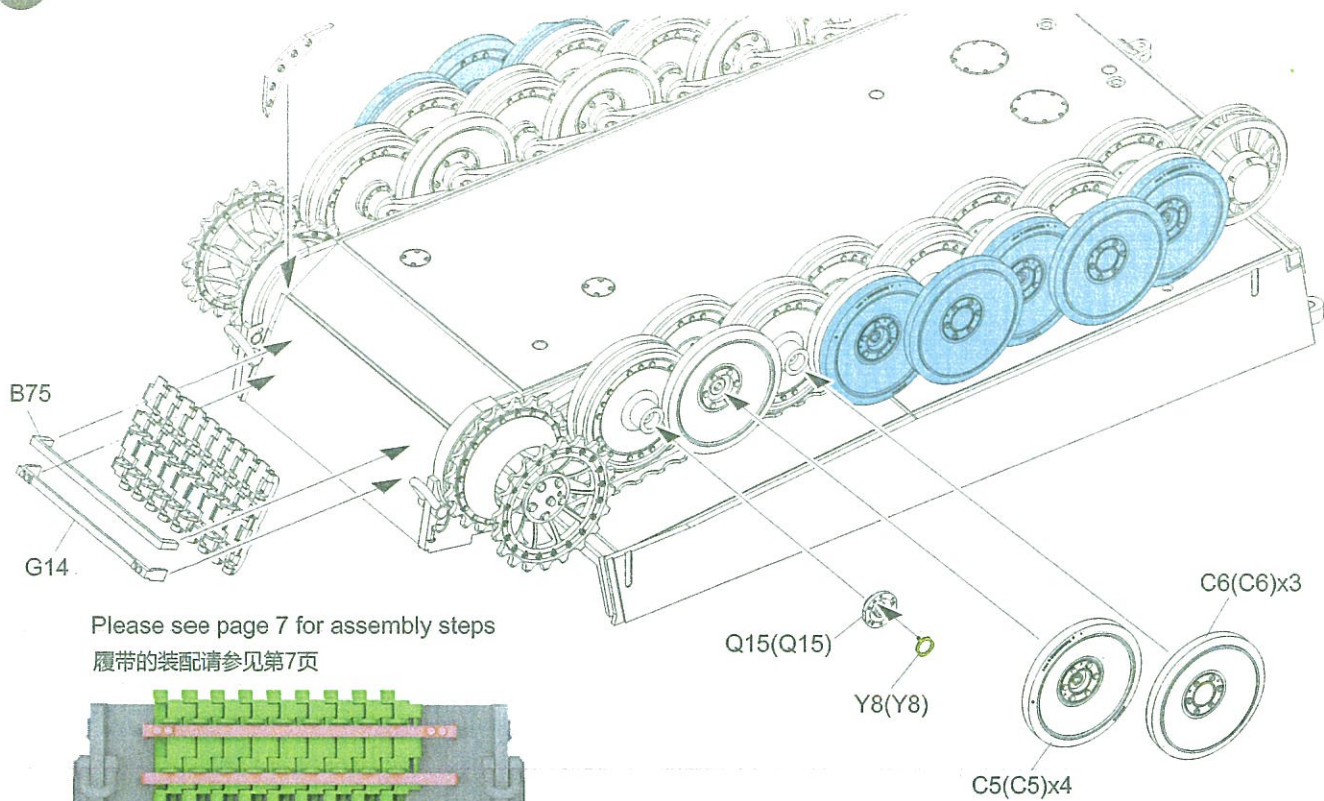

Please see page 7 for assembly steps
履带的装配请参见第7页

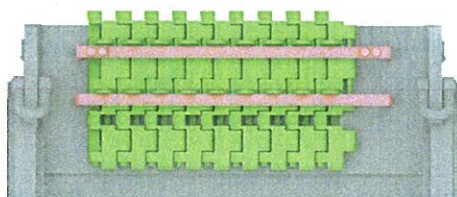

6

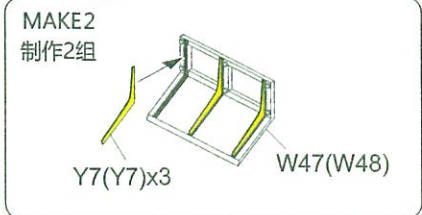
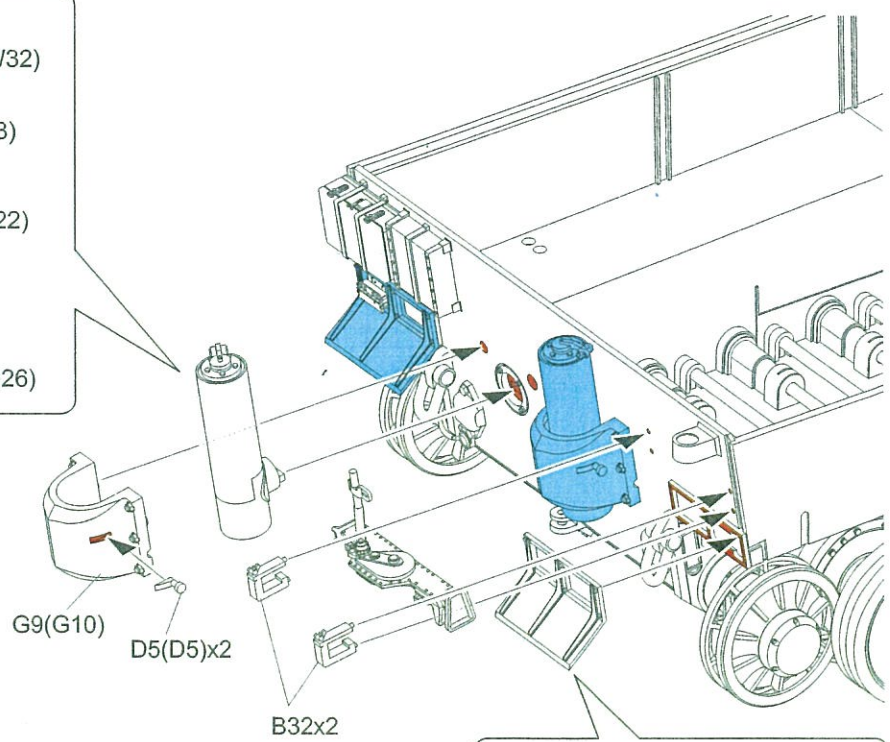
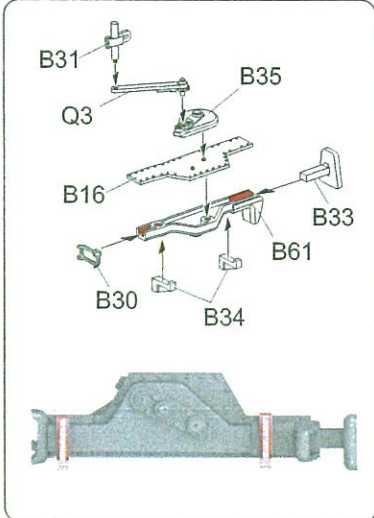
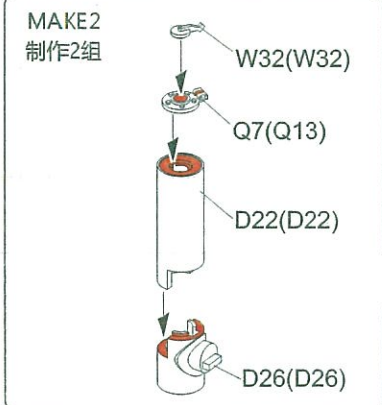

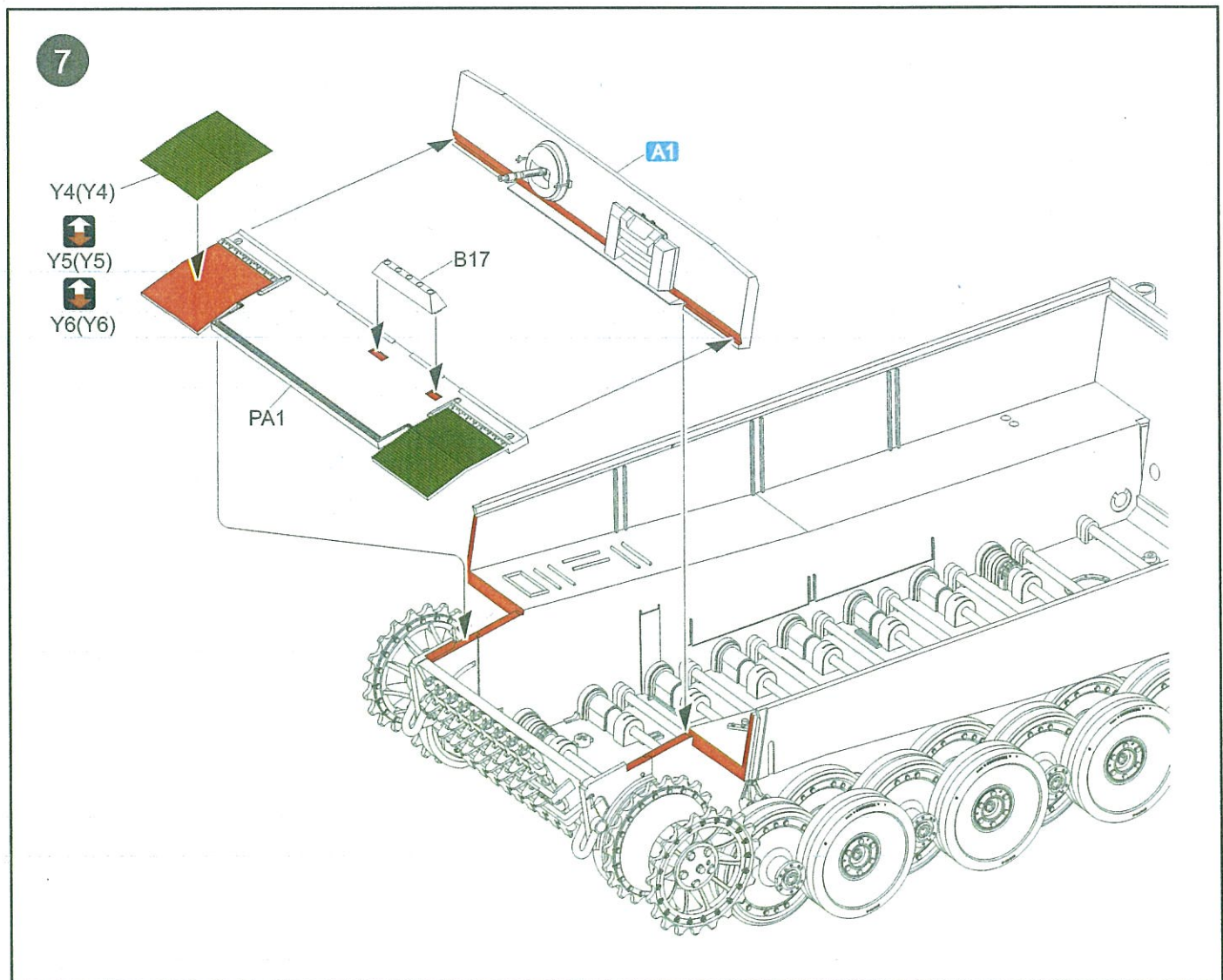
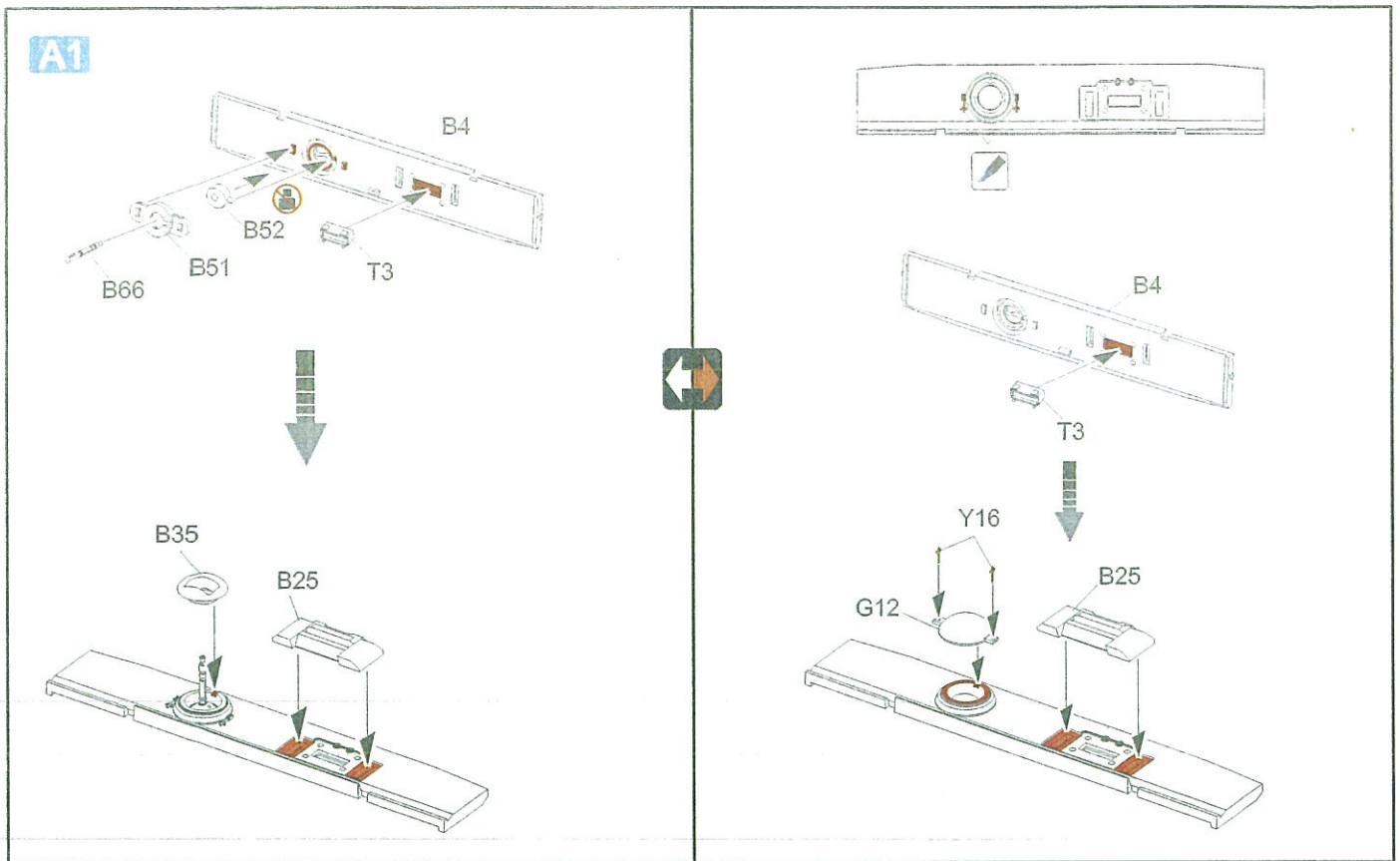

8

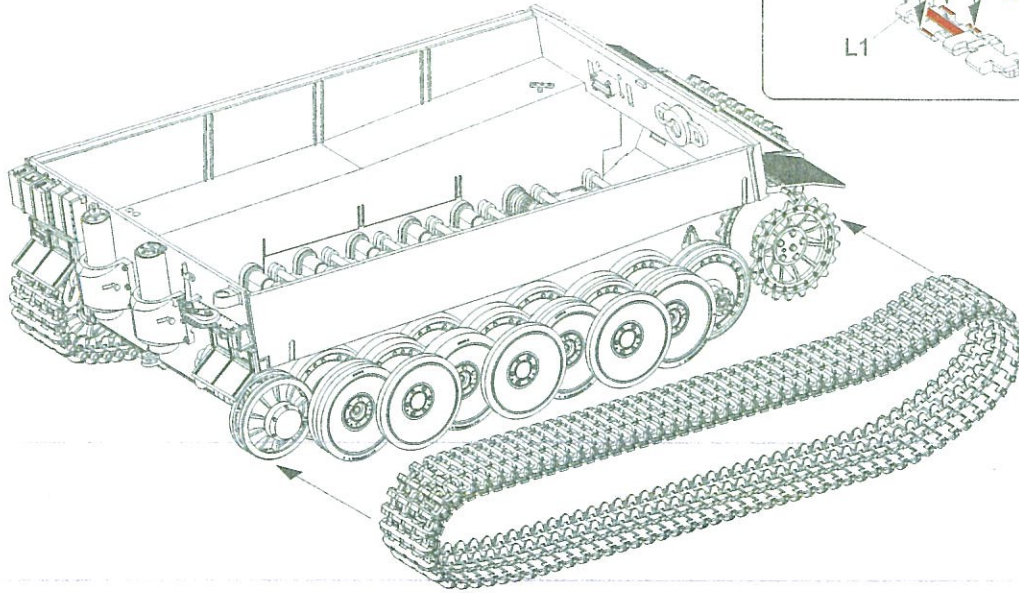

Style A
样式A

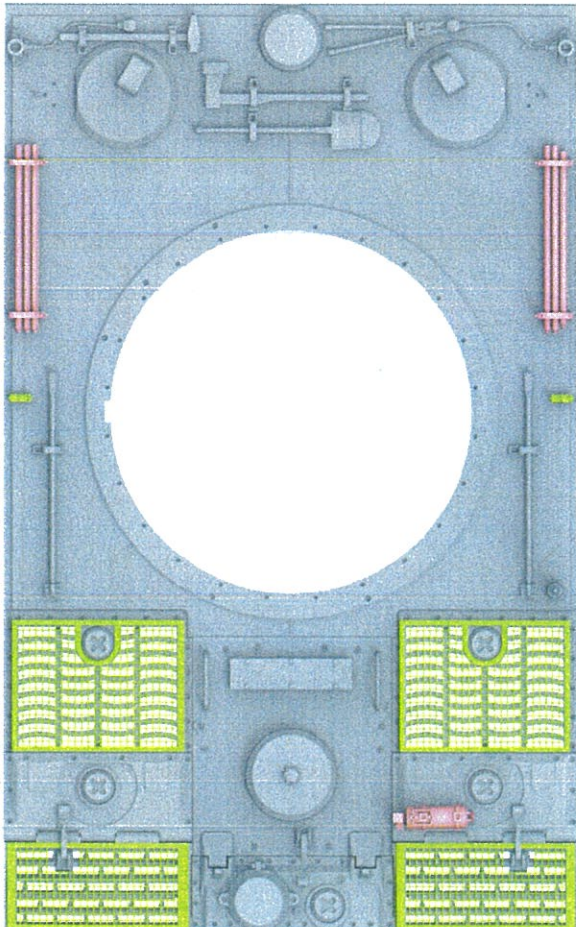

Style B
样式B

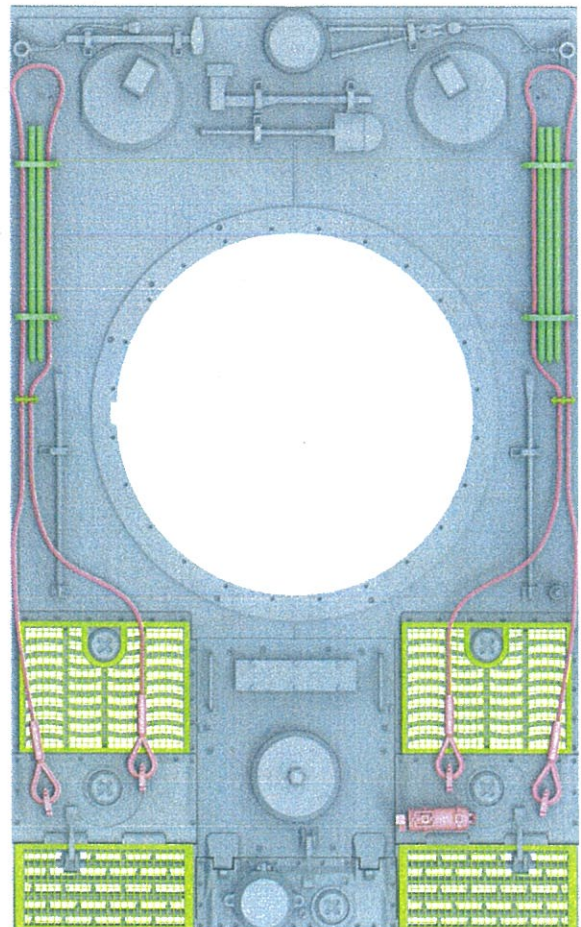

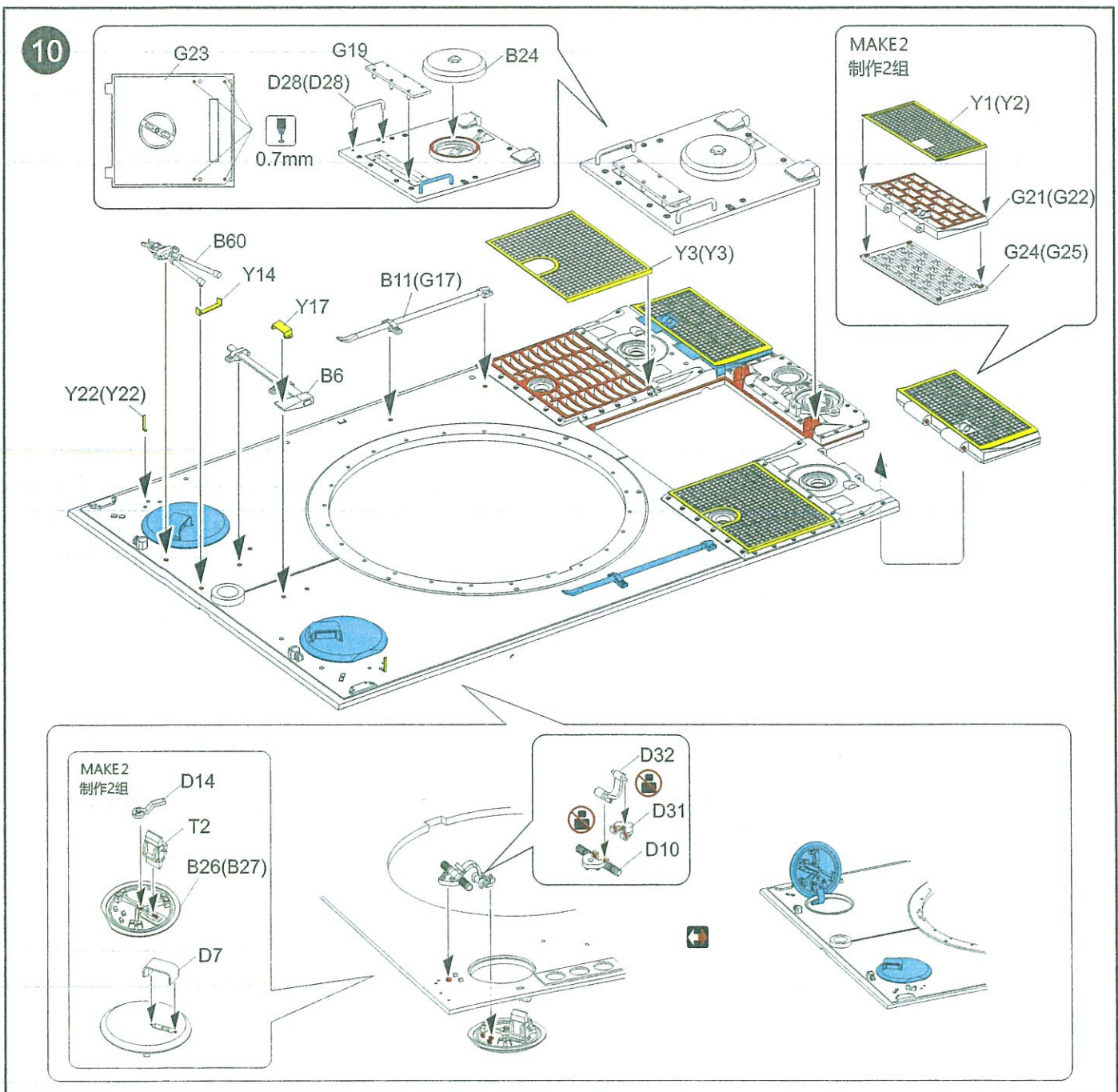
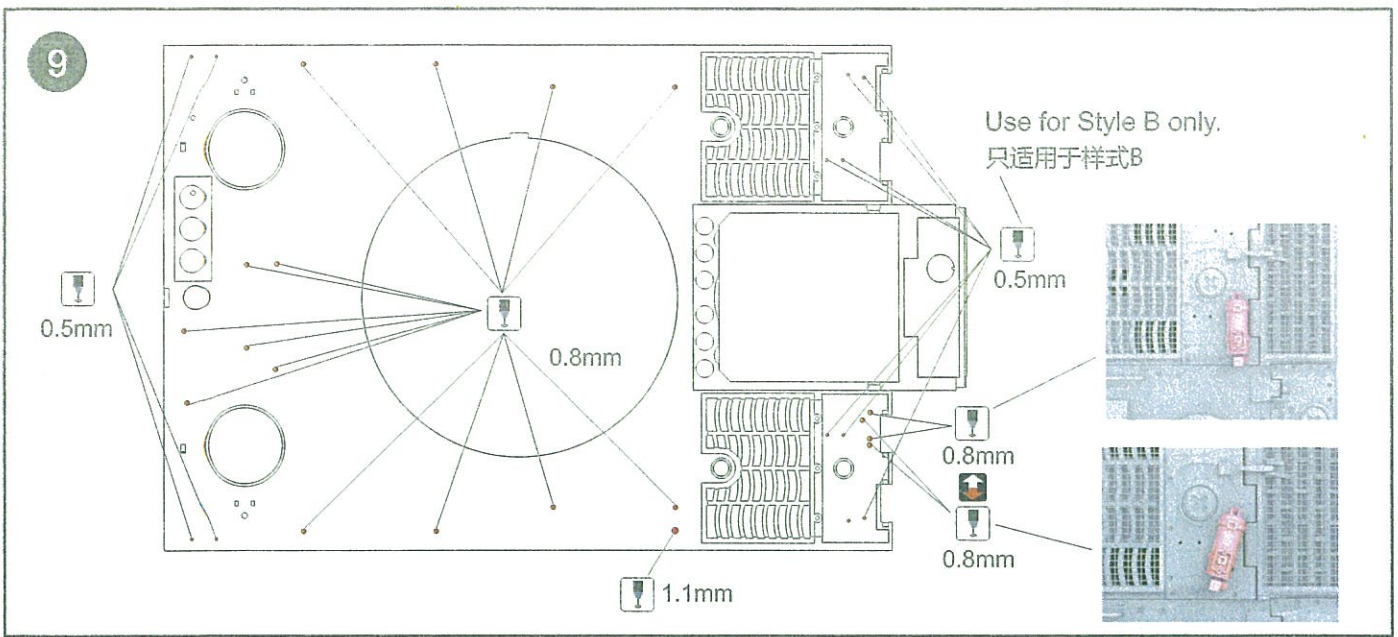

11

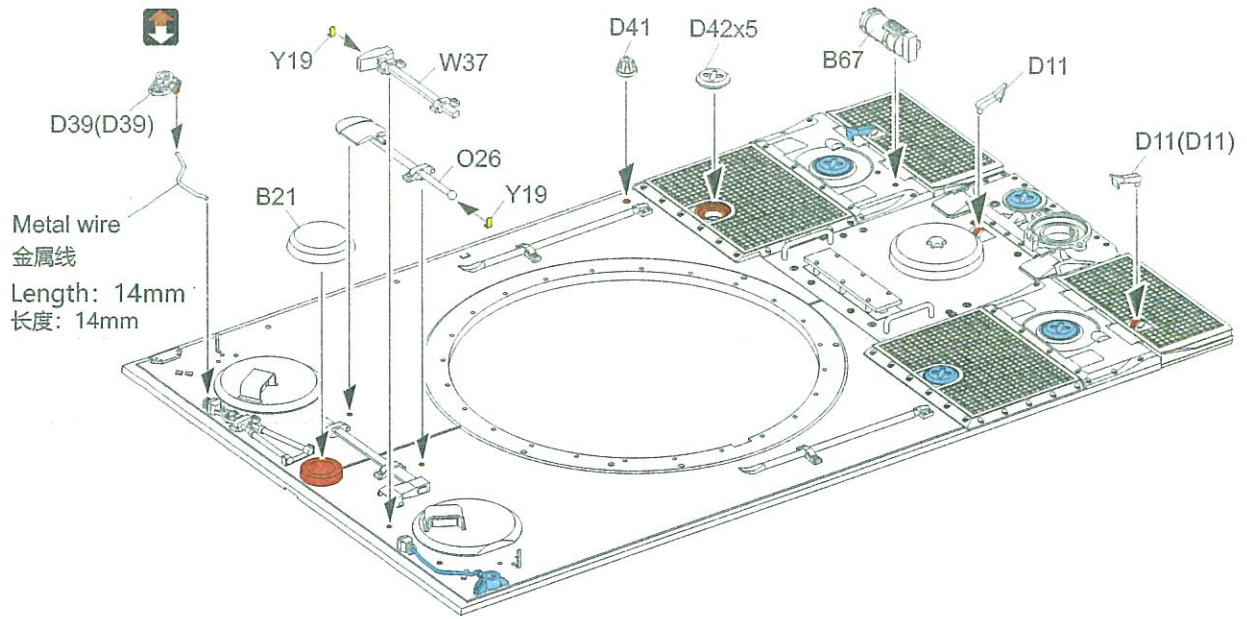
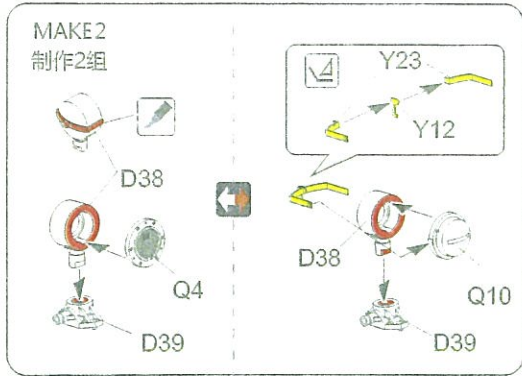

12

Style A
样式A

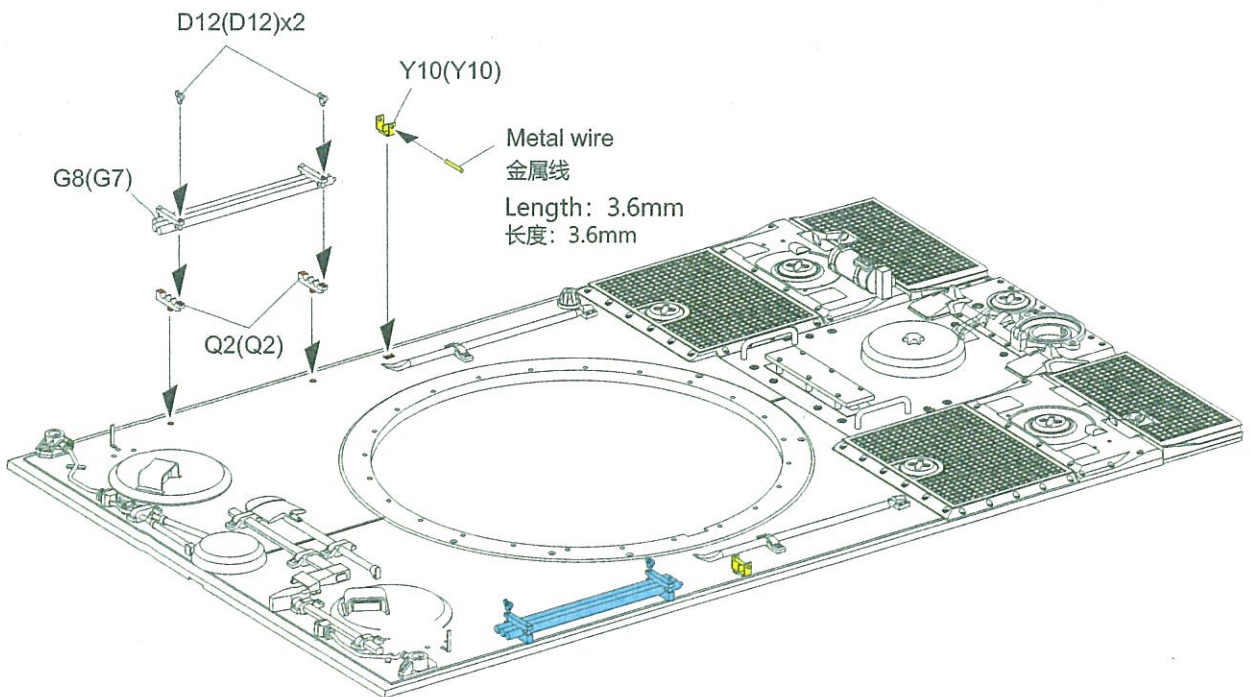

13

Style B
样式B

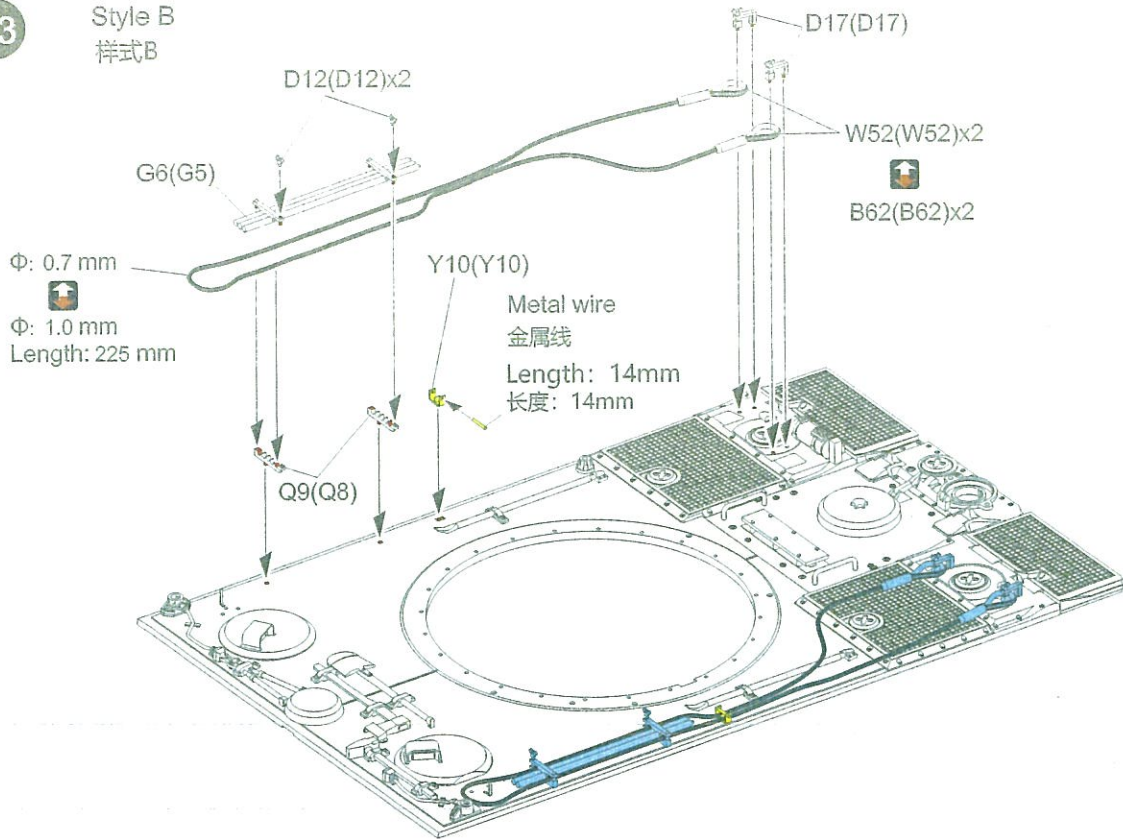

14

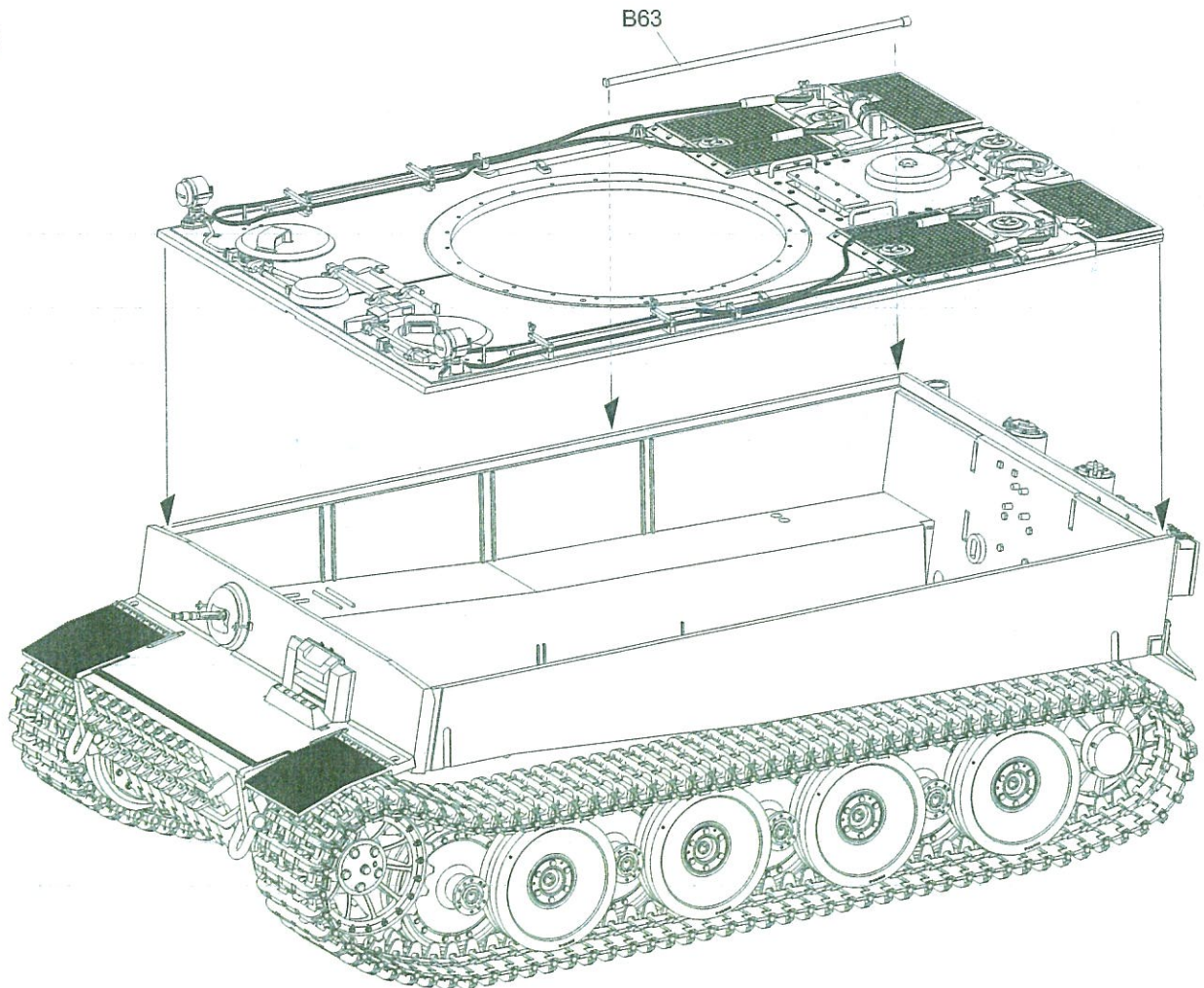

15

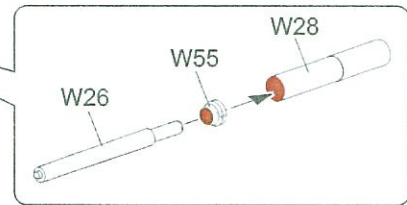
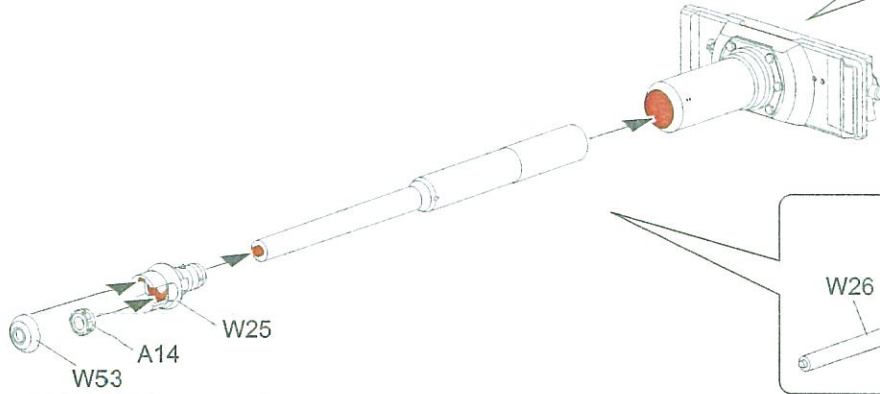
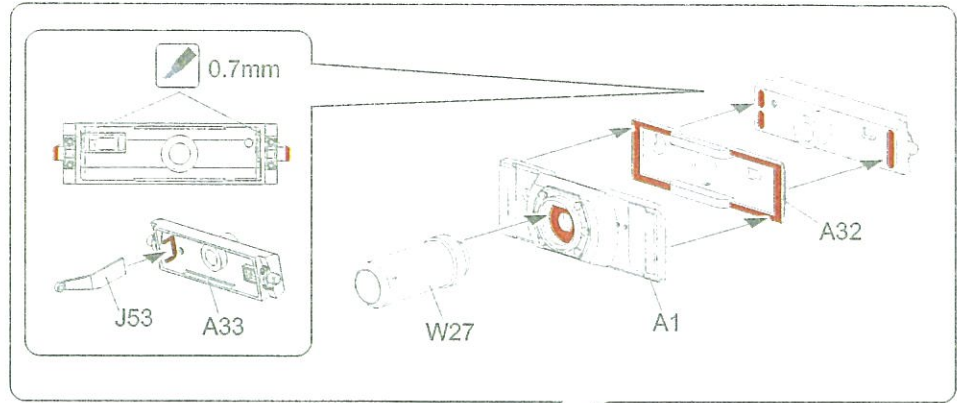

A2

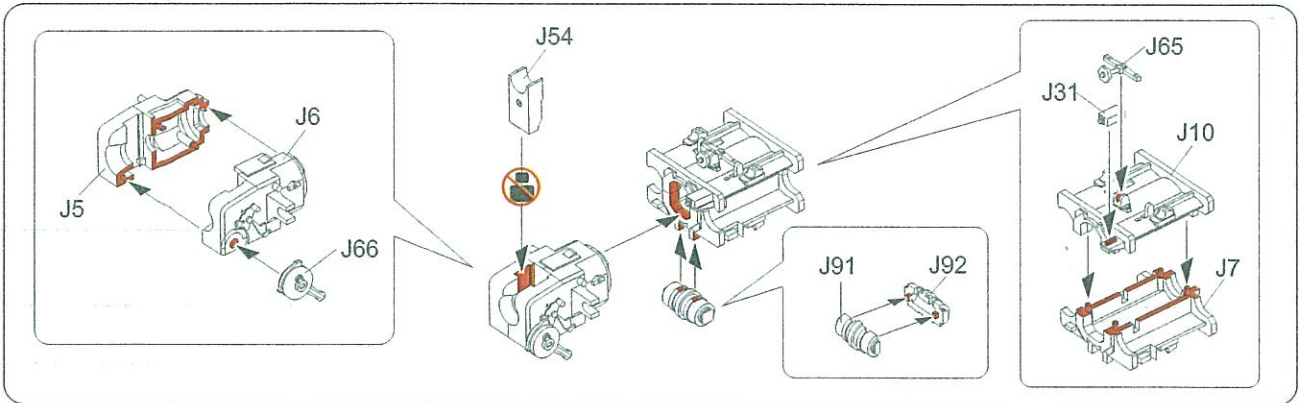

A3

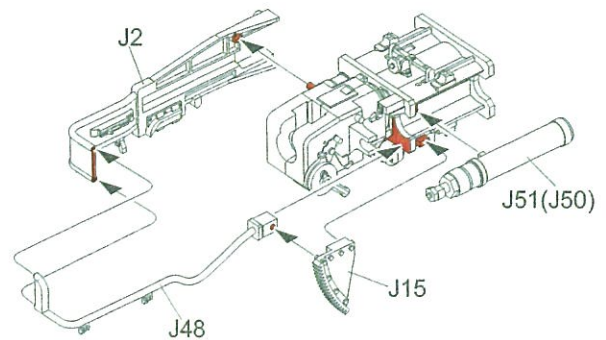
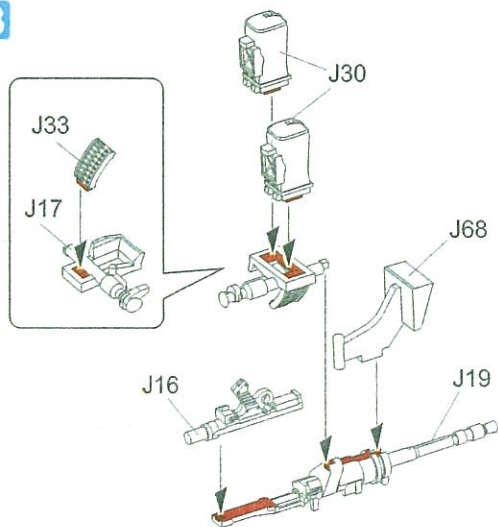

16

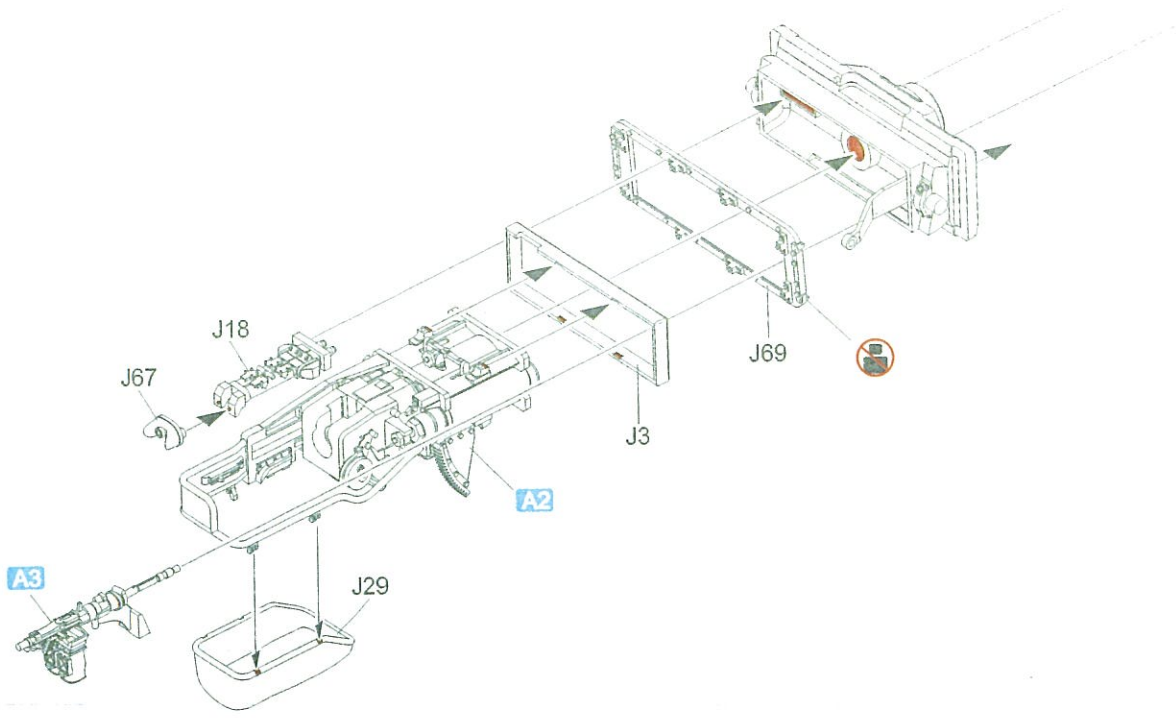

17

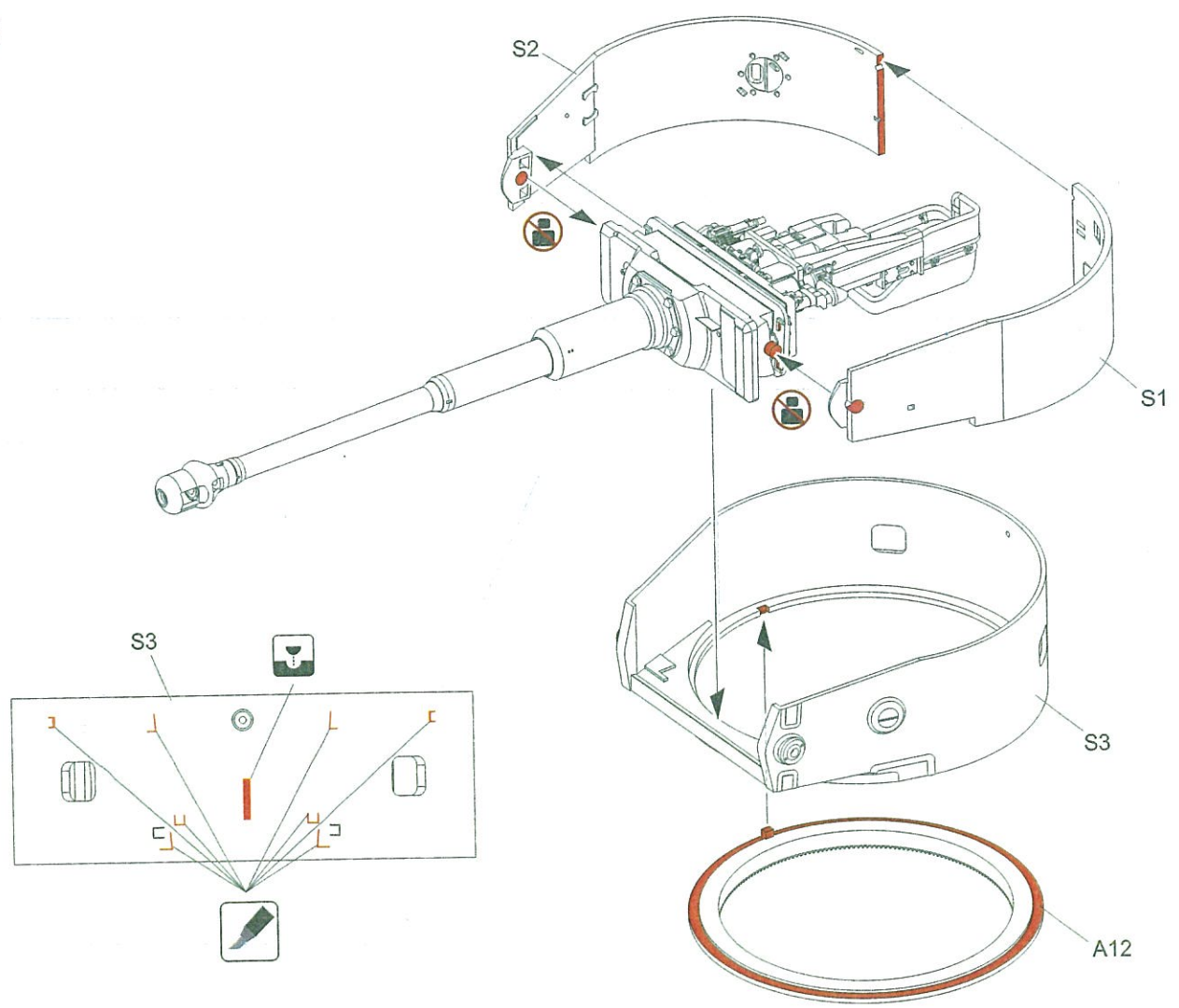

18

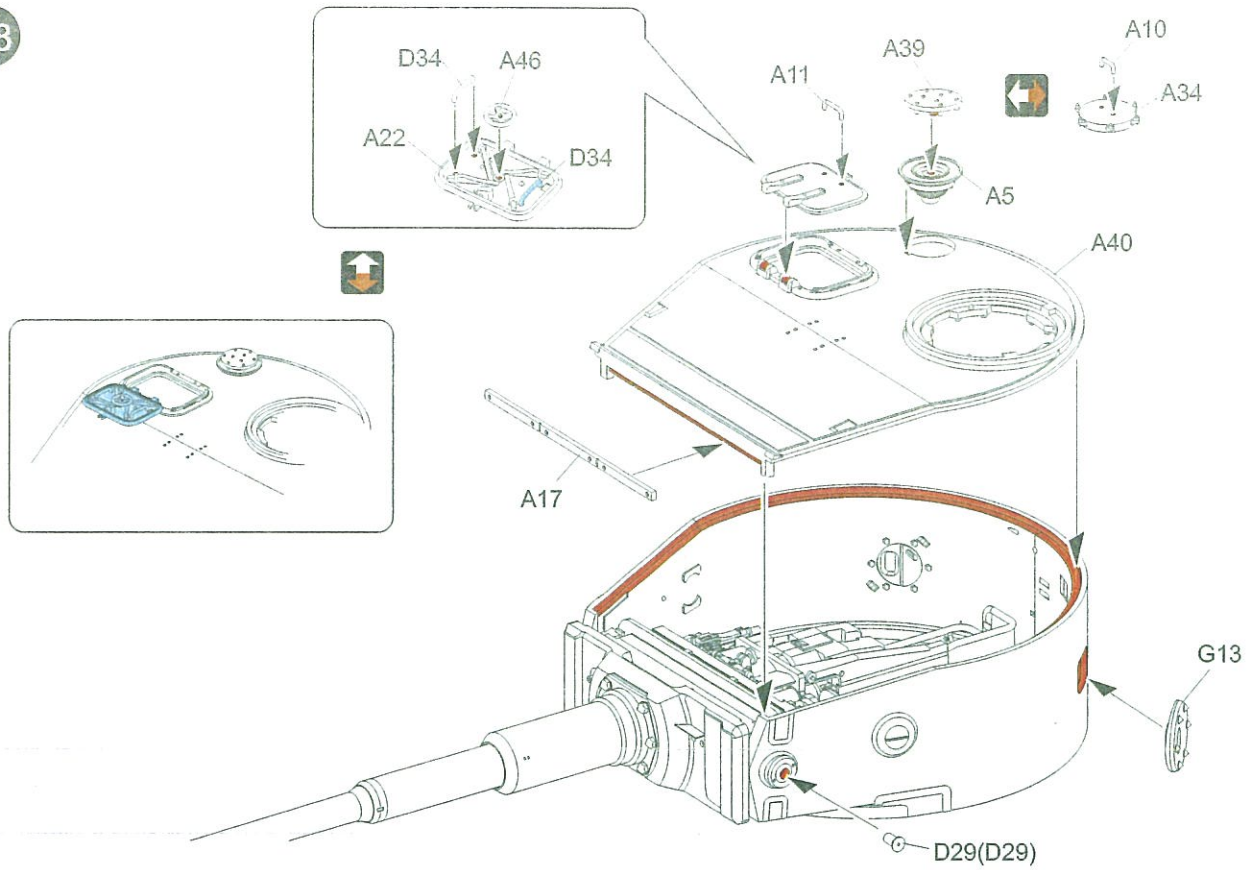

19

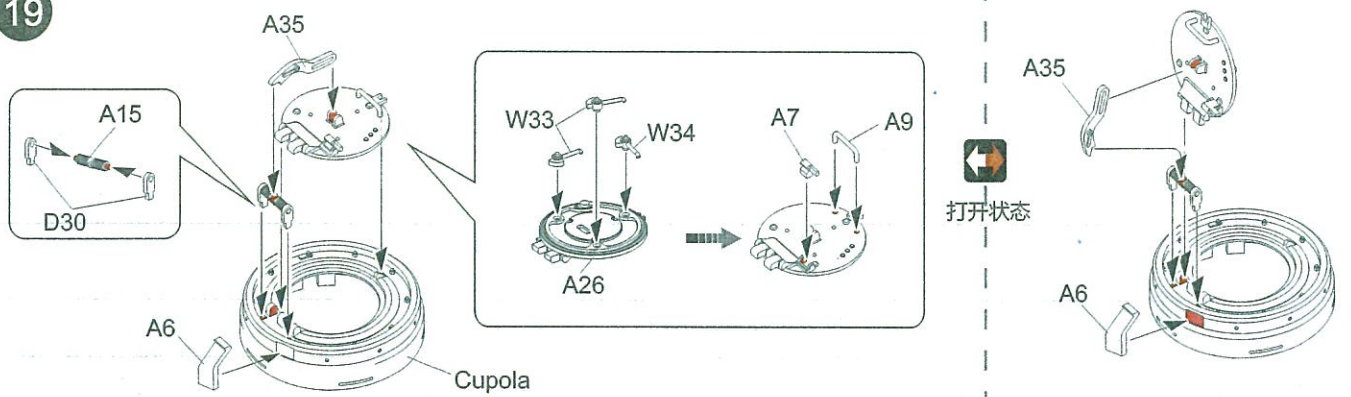

20

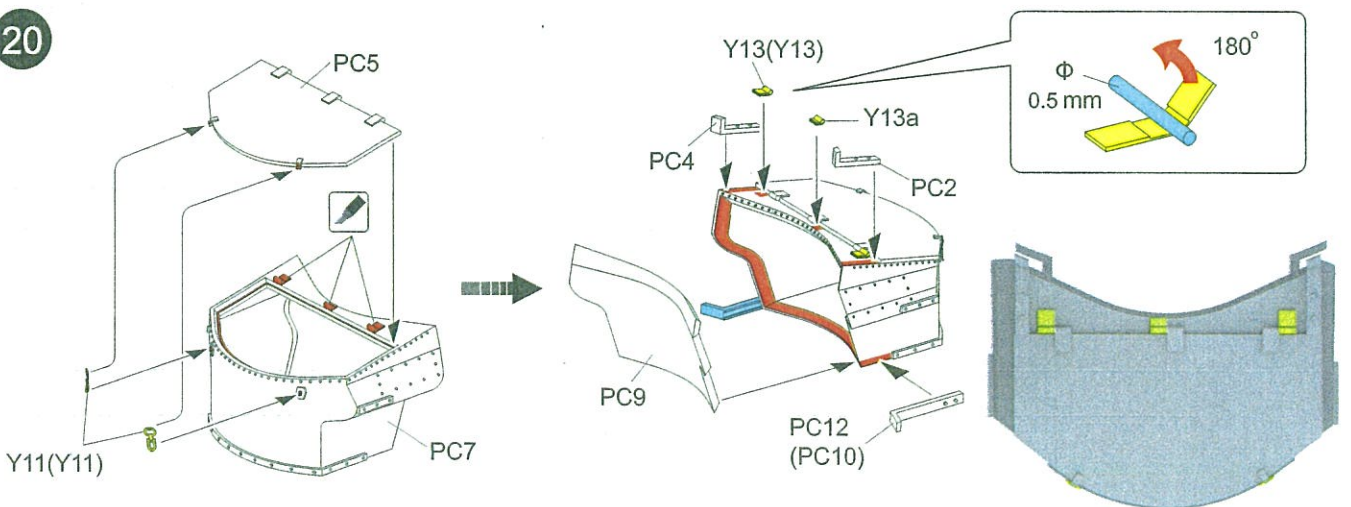

21

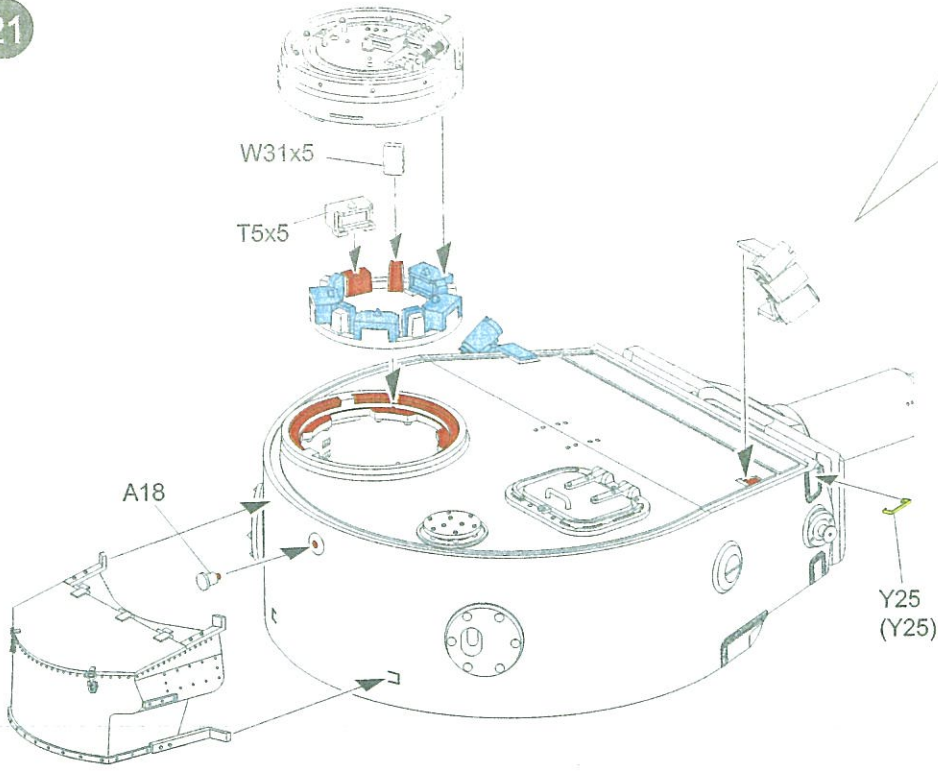

MAKE 2
制作2組
B28(B76)
D16x3
D4x3



3D打印件

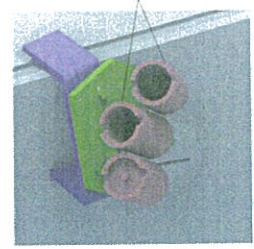

22

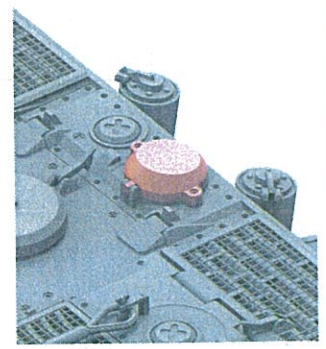
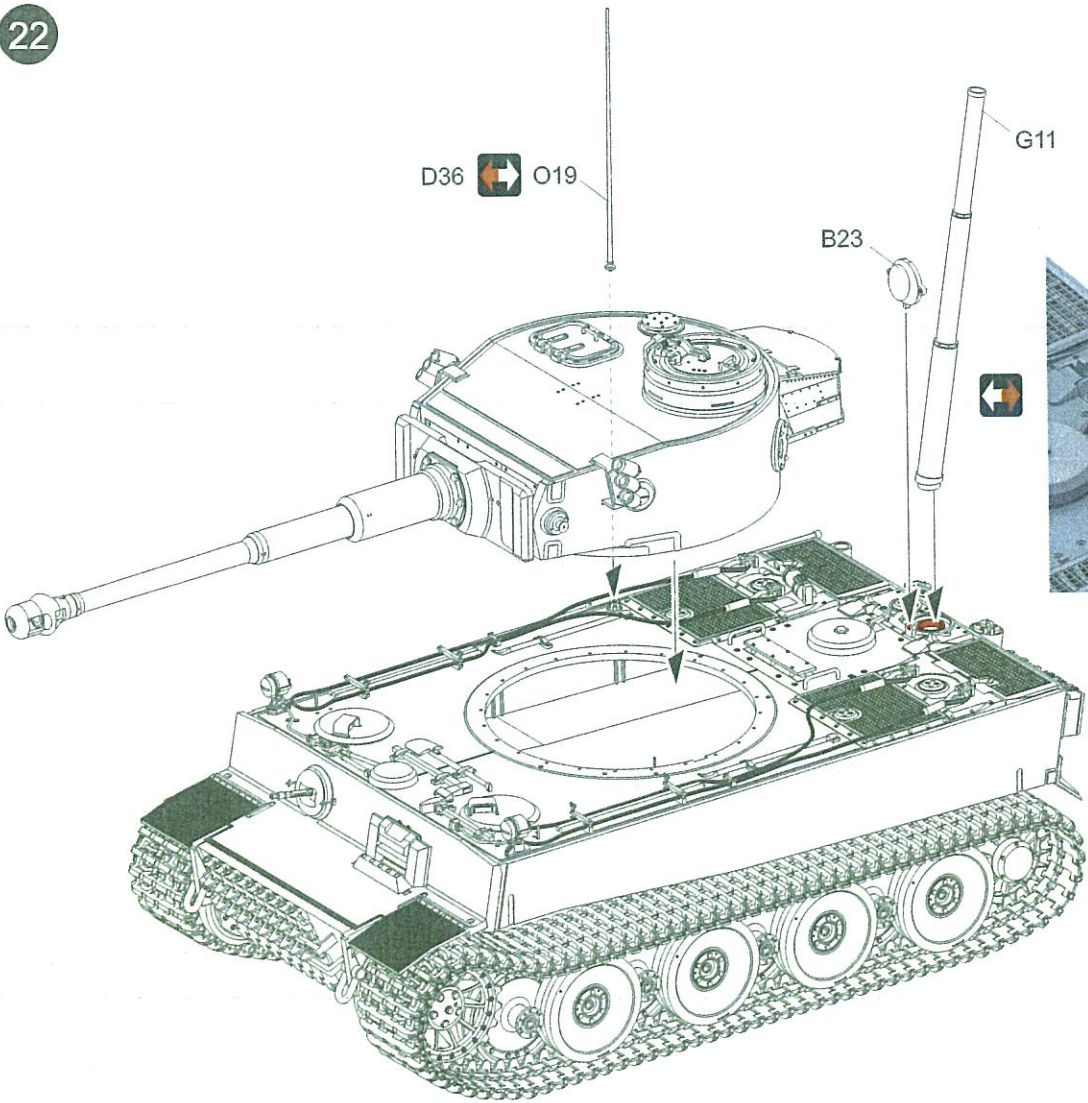

1/s Pz.Abt.502, near Leningrad, January 1943
1943年1月, 列宁格勒, 502重装甲营

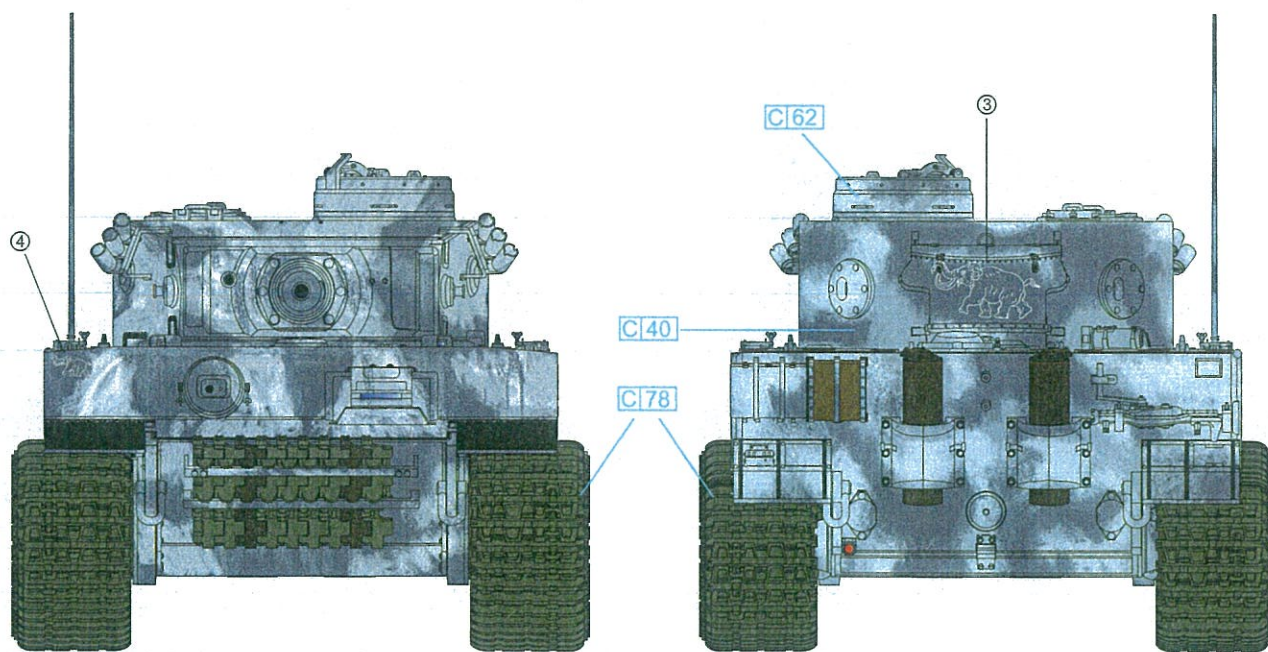
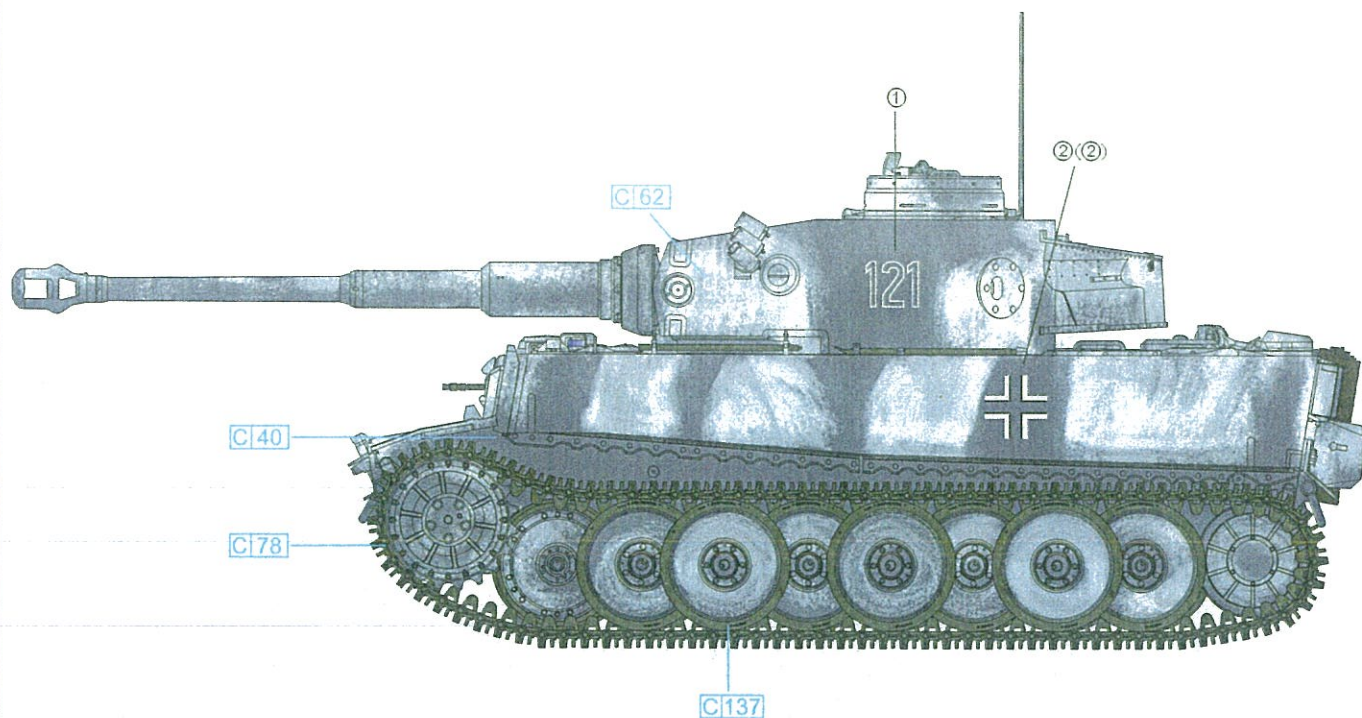

1/s Pz.Abt.502, near Leningrad, January 1943
1943年1月, 列宁格勒, 502重装甲营

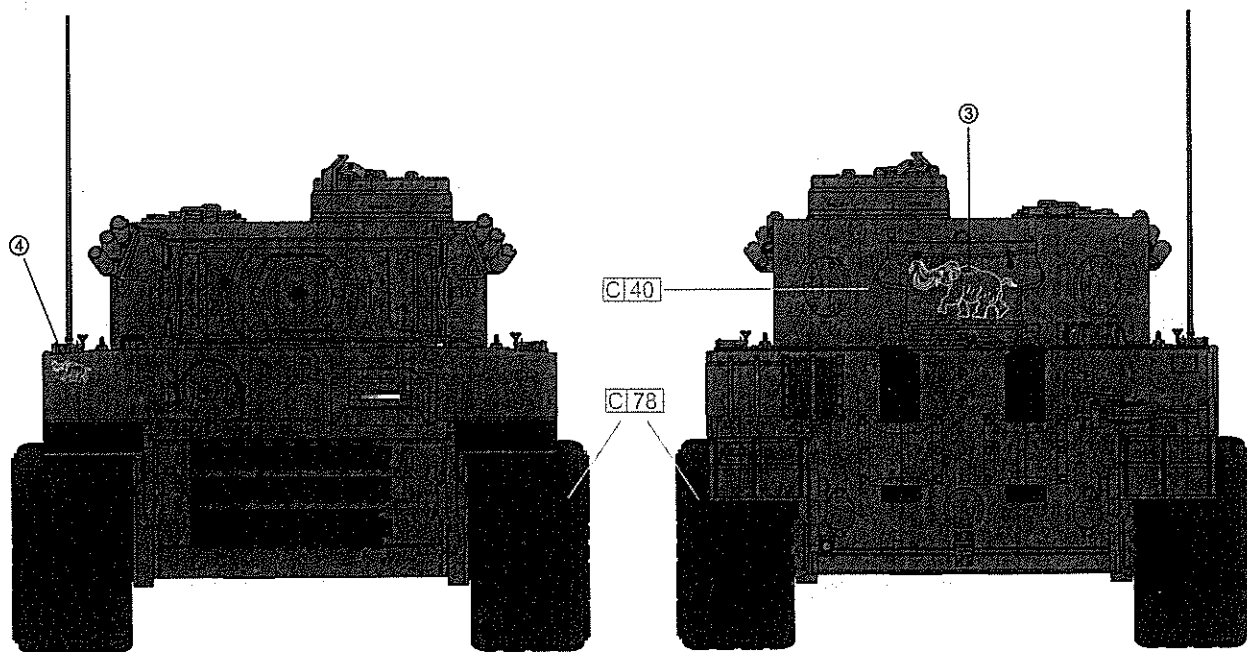
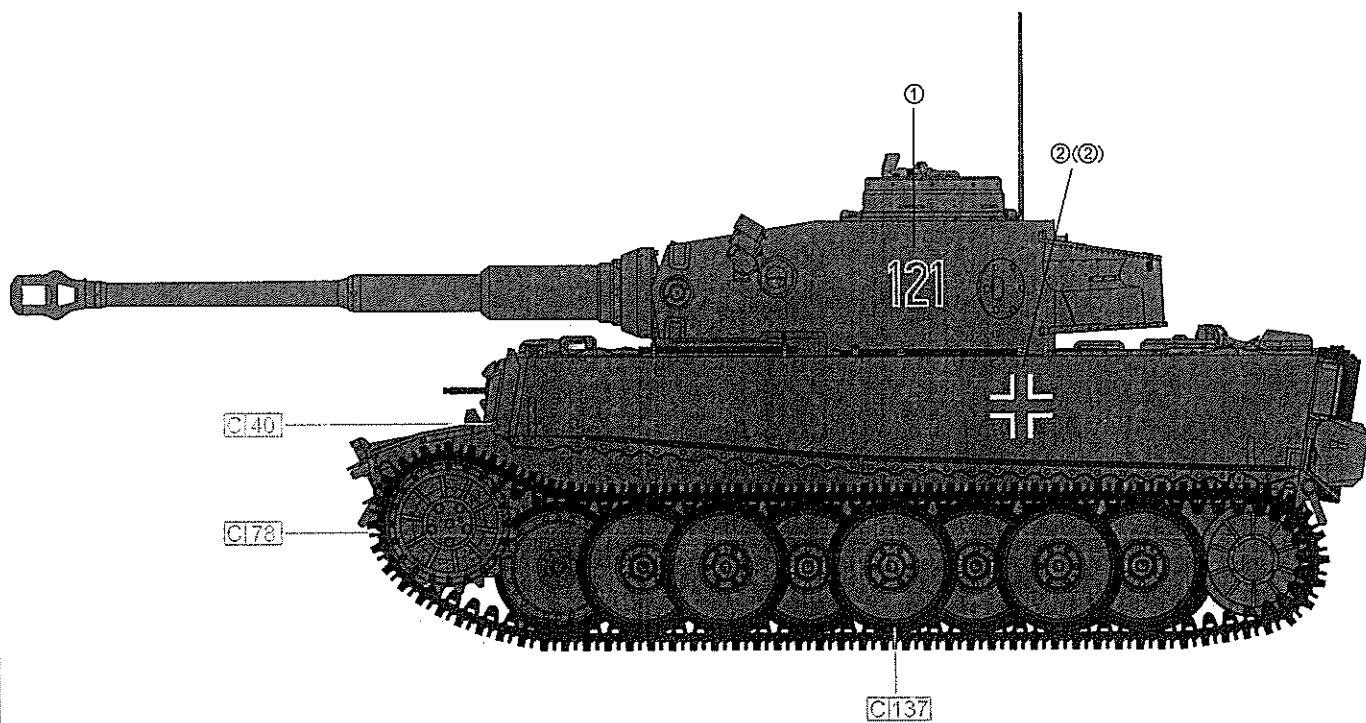

Page 2
第2页

V x 4 V sprue not included

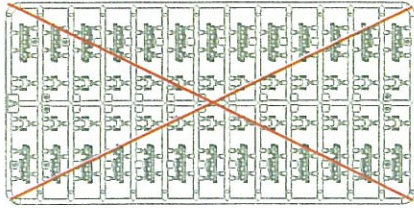

L x 35

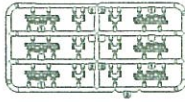

Step 4 on page 4
第4页之第4步



D53(D53)

Step 18 on page 13
第13页之第18步

D24(G13)

