

# RCAF CF-104D Starfighter

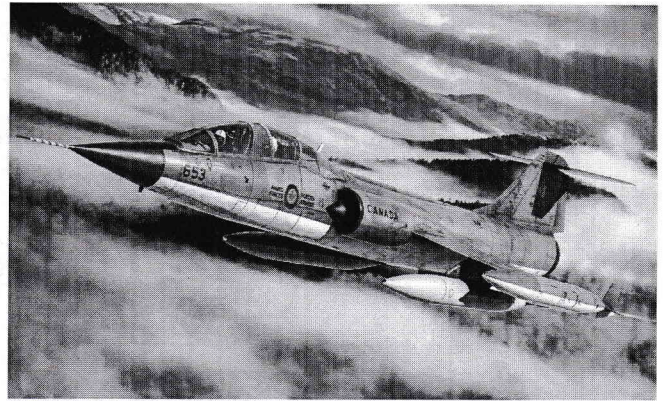

## RCAF CF-104D Starfighter

On the early 1960's the Royal Canadian Air Force (RCAF) was looking for a new supersonic aircraft to substitute the F-86 Sabre. The choice was to produce locally the Canadair CF-104 Starfighter (CF-111, CL-90), which was a modified version of the Lockheed F-104 Starfighter supersonic fighter aircraft built under licence. It was primarily used as a ground attack aircraft, despite being designed as an interceptor. It served with the RCAF and later the Canadian Armed Forces until it was replaced by the McDonnell Douglas CF-118 Hornet.

CF-104 was optimized for the nuclear strike/reconnaissance role, fitted with R-24A NASARR equipment dedicated to the air-to-ground mode only as well as having provision for a ventral reconnaissance pod equipped with four Vinten cameras. Other differences included retaining the removable refueling probe, initial deletion of the fuselage-mounted 20 mm (.79 in) M61A1 cannon (replaced by an additional fuel cell) and the main undercarriage members being fitted with longer-stroke liquid springs and larger tires.

The Twin Seater Variant called CF-104D was full operational for the same missions of the Single Seater, but normally fly unarmed. They served as Operational Conversion Aircraft, preparing new pilots for the Starfighter. In total 200 CF-104 are built by Canadair for the Royal Canadian Air Force.

### CAUTION

- \*Read carefully and fully understand the instructions before commencing assembly.
- \*Keep out of reach of children. Children must not be allowed to put any parts in their mouths, or pull plastic bag over their heads.
- \*When using adhesives and paints, please make sure not to use them in closed room or near the fire.
- \*When assembling this kit, tools including knives are used. Extra care should be taken to avoid injury.

**WARNING: CONTAIN SMALL PARTS NOT FOR CHILDREN UNDER 14 YEARS OF AGE.**



Drill



Remove



2 Set



Bend



Optional



Decal



Super Glue



Fill Hole



No Cement



Be Careful

### TOOLS RECOMMENDED

Cement

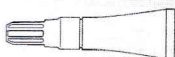

Side Cutter

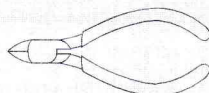

Modeling Knife

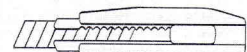

Tweezers

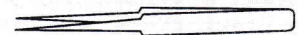

**AFTERMARKET SERVICES CARD**

When requesting replacement parts, please take or send<sup>a</sup> this form to your local dealer so that the parts required can be correctly identified. Please note that specifications and availability are subject to change without notice. Or visit <http://www.kineticmodel.com> for latest information. For more information, please contact [services@kineticmodel.com](mailto:services@kineticmodel.com)

Part Code	K48095	Qty	Item
00-165-001	1/48 F-104G FUESLAGE, COCKPIT, ACCESSORIES	1	A
00-165-002	1/48 F-104 WINGS, TANK ACCESSORIES	1	B
00-165-003	1/48 F-104 NLG,MLG PARTS	2	C
00-165-004	1/48 F-104G/TF-104G CANOPY	1	D
00-165-005	1/48TF-104G FUESLAGE	1	E
01-165-48095	1/48 RCAF CF-104D	1	Decal
03-165-48095	1/48 RCAF CF-104D	1	MANUAL
06-165-48089	1/48 F-104/TF-104 PE	1	PE

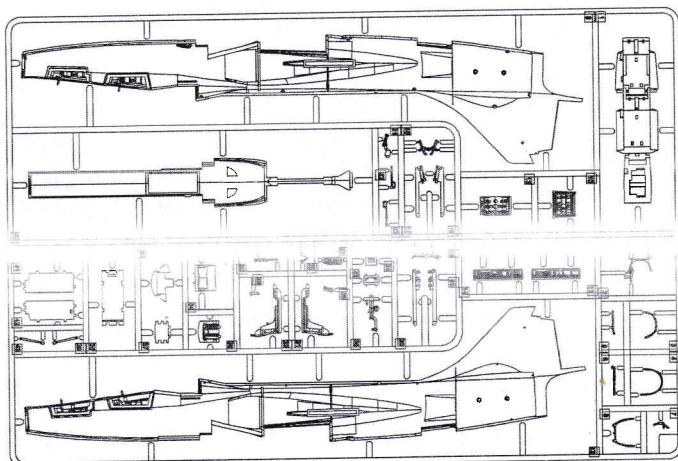
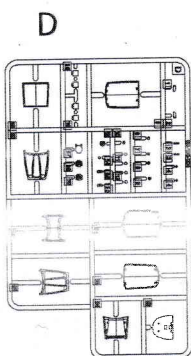
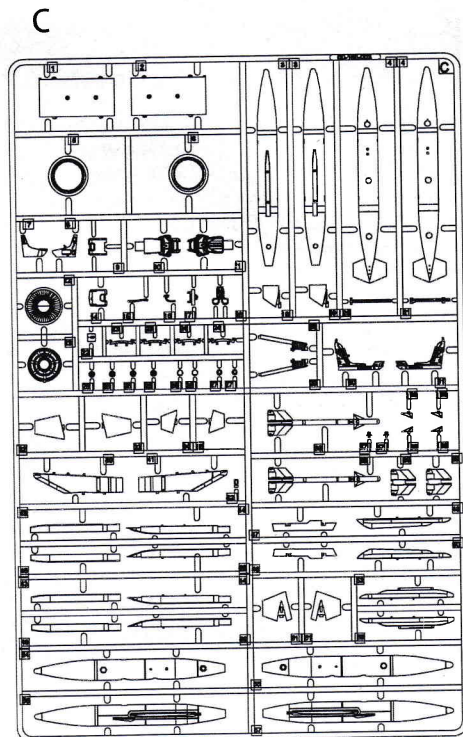
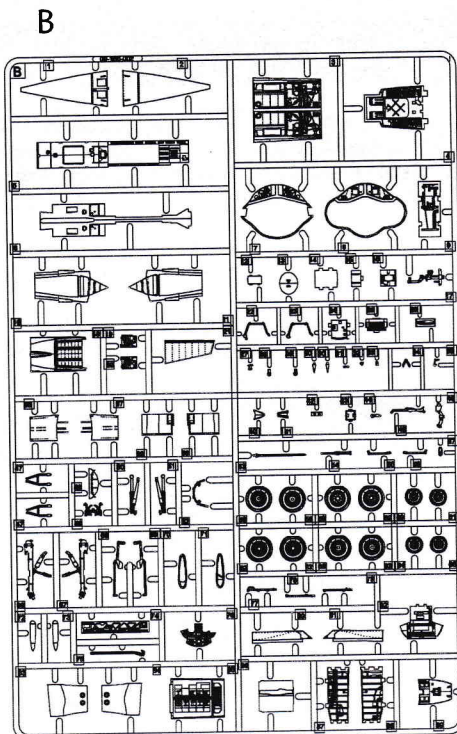
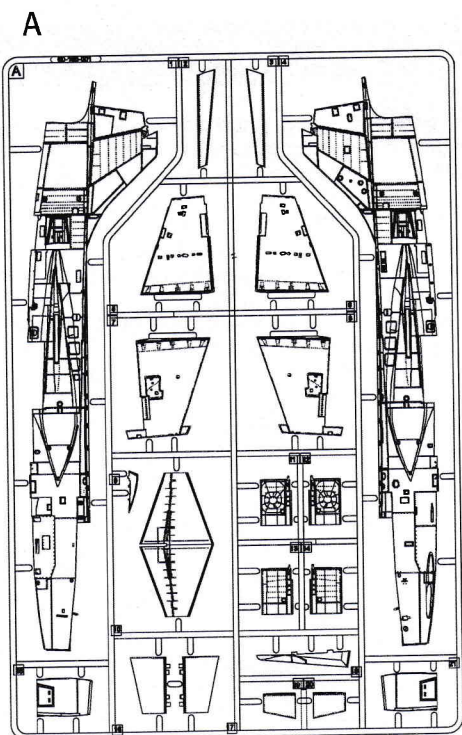



COLOR	AMMO MIG	VALLEJO MODEL COLOR	GSICREOS MR. COLOR	TAMIYA ENAMEL/ACRYLIC	HUMBROL ENAMEL
RUBBER & TIRES	A.MIG-033	70.306	137	XF-85	-
MATT BALCK	A.MIG-046	71.057	33	XF-1	33
SATIN WHITE	A.MIG-047	70.842	1	X-2	22
YELLOW	A.MIG-048	71.002	4	XF-3	69
RED	A.MIG-049	71.003	3	XF-7	153
FRENCH BLUE	A.MIG-062	70.900	72	XF-18	-
NATO GREEN	A.MIG-084	71.093	54	XF-67	117
CRYSTAL GREEN	A.MIG-092	70.936	138	X-25	-
CRYSTAL RED	A.MIG-093	70.934	47	X-27	220
JET EXHAUST BURNT IRON	A.MIG-187	71.073	61	XF-84	-
STEEL	A.MIG-191	70.864	28	-	27003
SILVER	A.MIG-195	71.063	8	X-11	11
FS 26231	A.MIG-205	71.051	317	-	27
SILVER GRAY	A.MIG-212	71.119	332	-	-
BS283	A.MIG-219	71.126	364	-	-
FS 33481	A.MIG-221	71.107	27	XF-4	-
CHROME	A.MIG-8205	71.064	SM206	X-11	191

For Color Profile, please go to [www.kineticmodel.com](http://www.kineticmodel.com) for download  
(type the kit# and go for manual/painting guide)

1

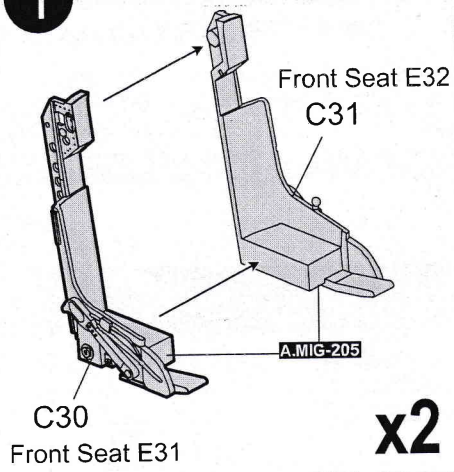

x2

2

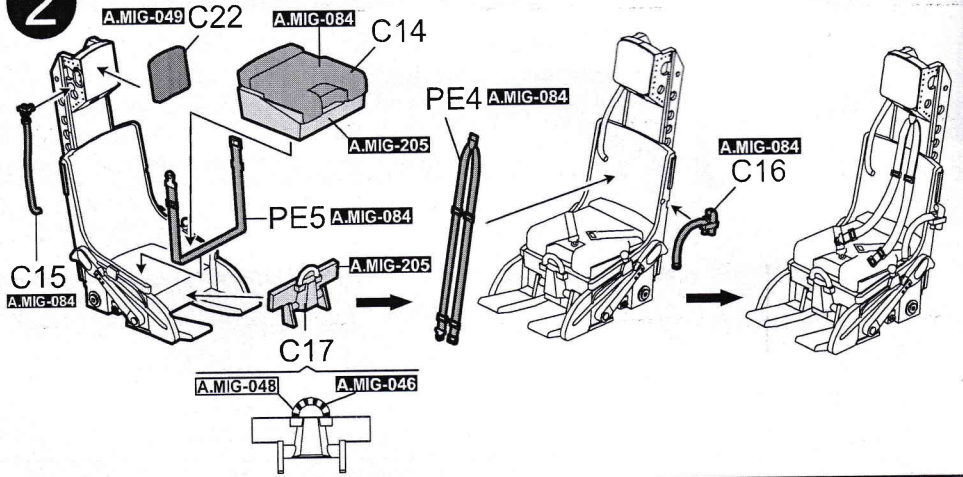

3

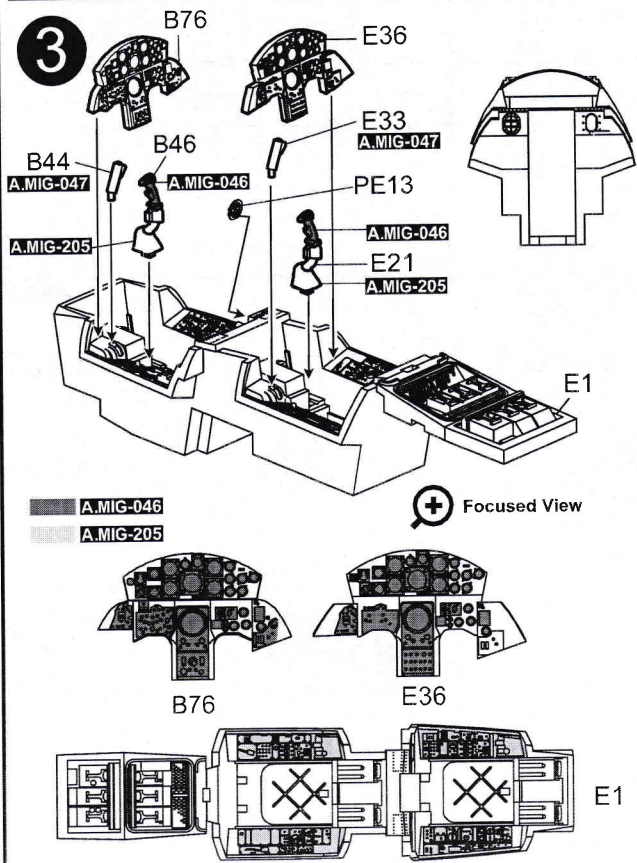

4

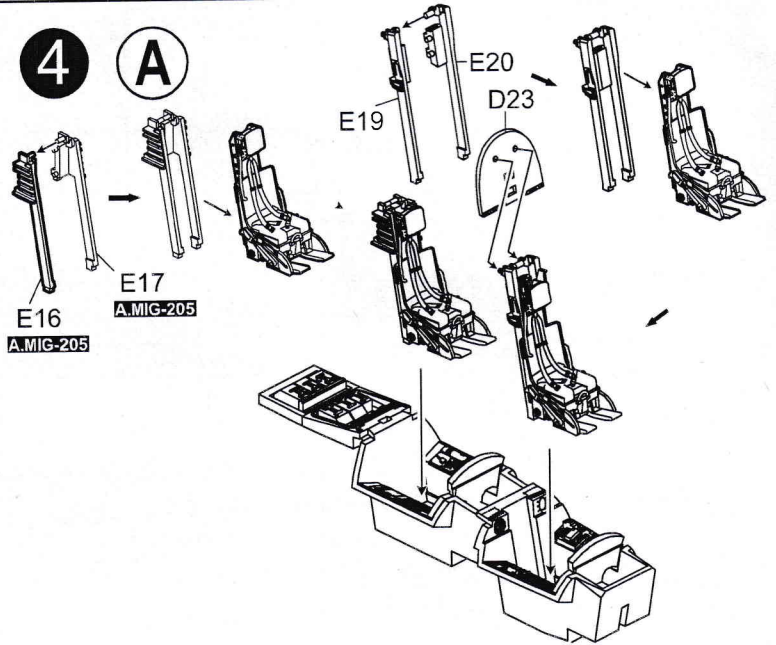

6

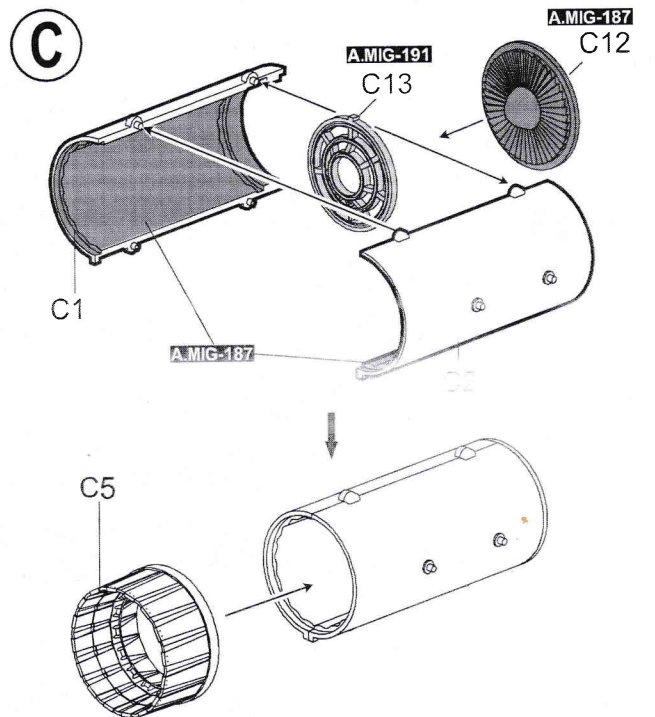

5

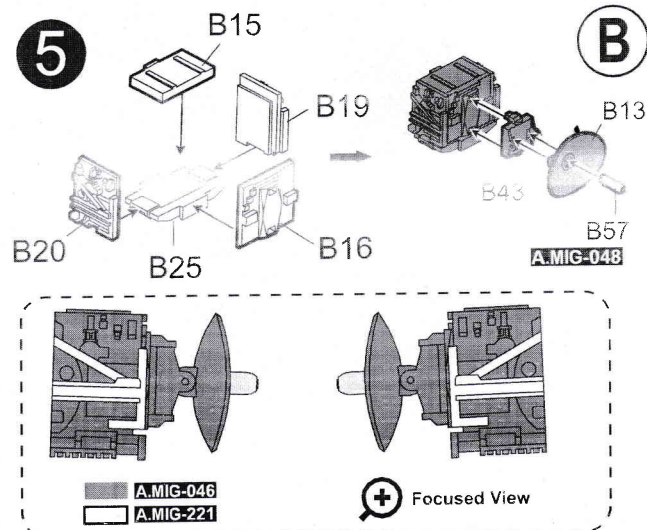

7

D

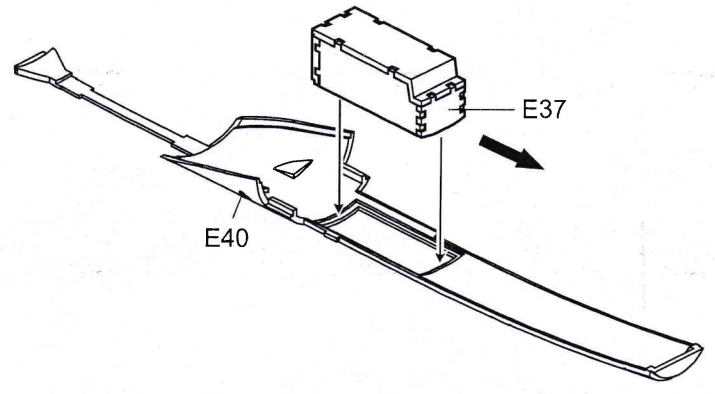
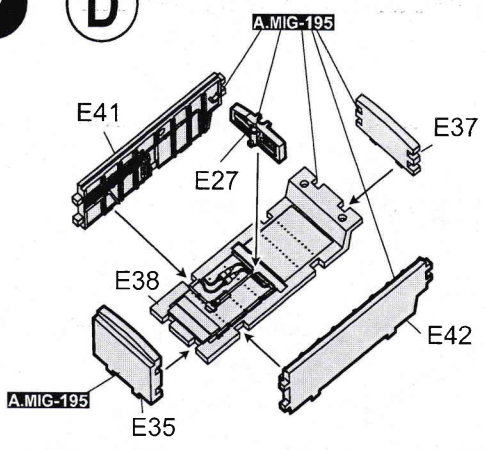

8

E

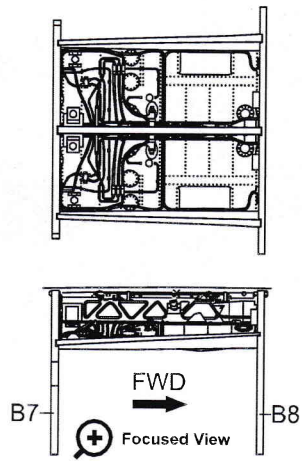
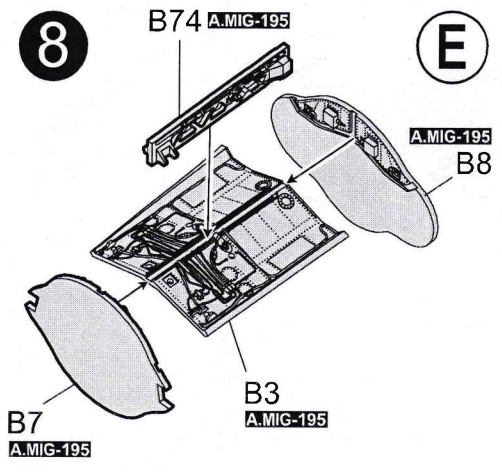

9

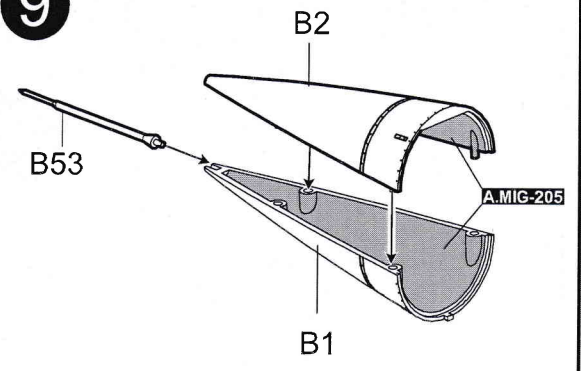

10

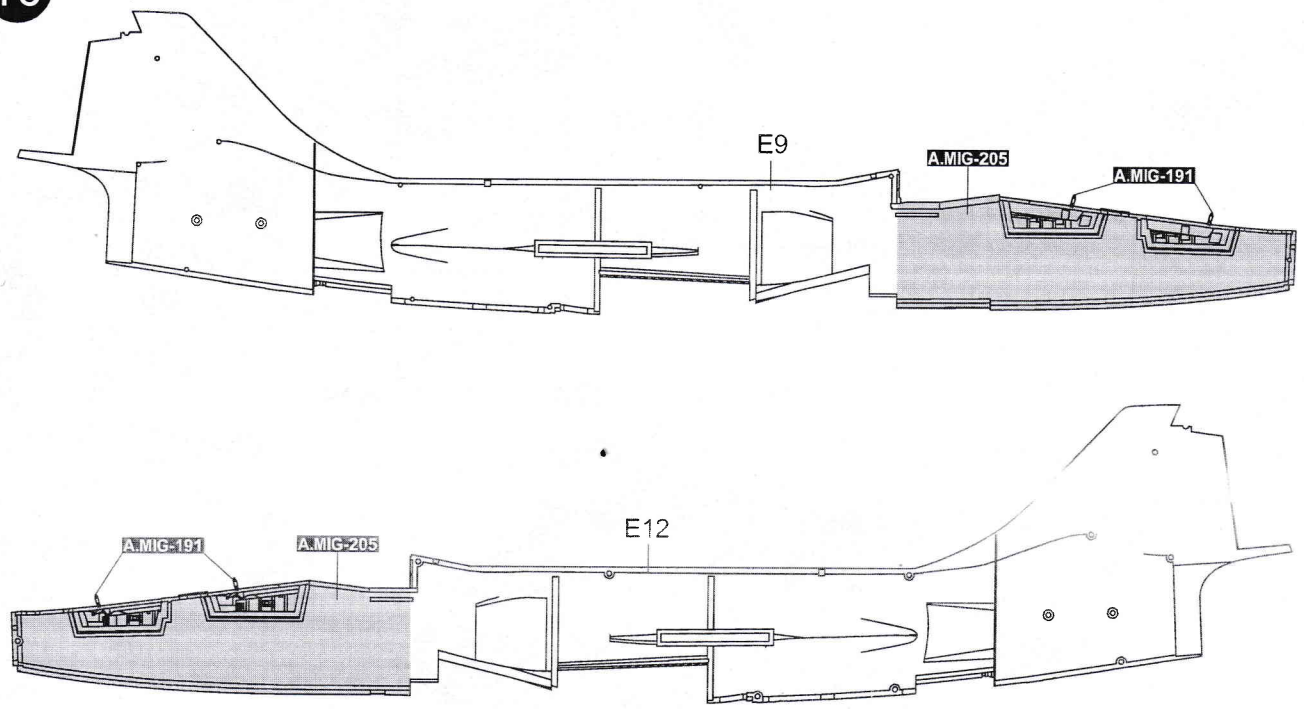

11

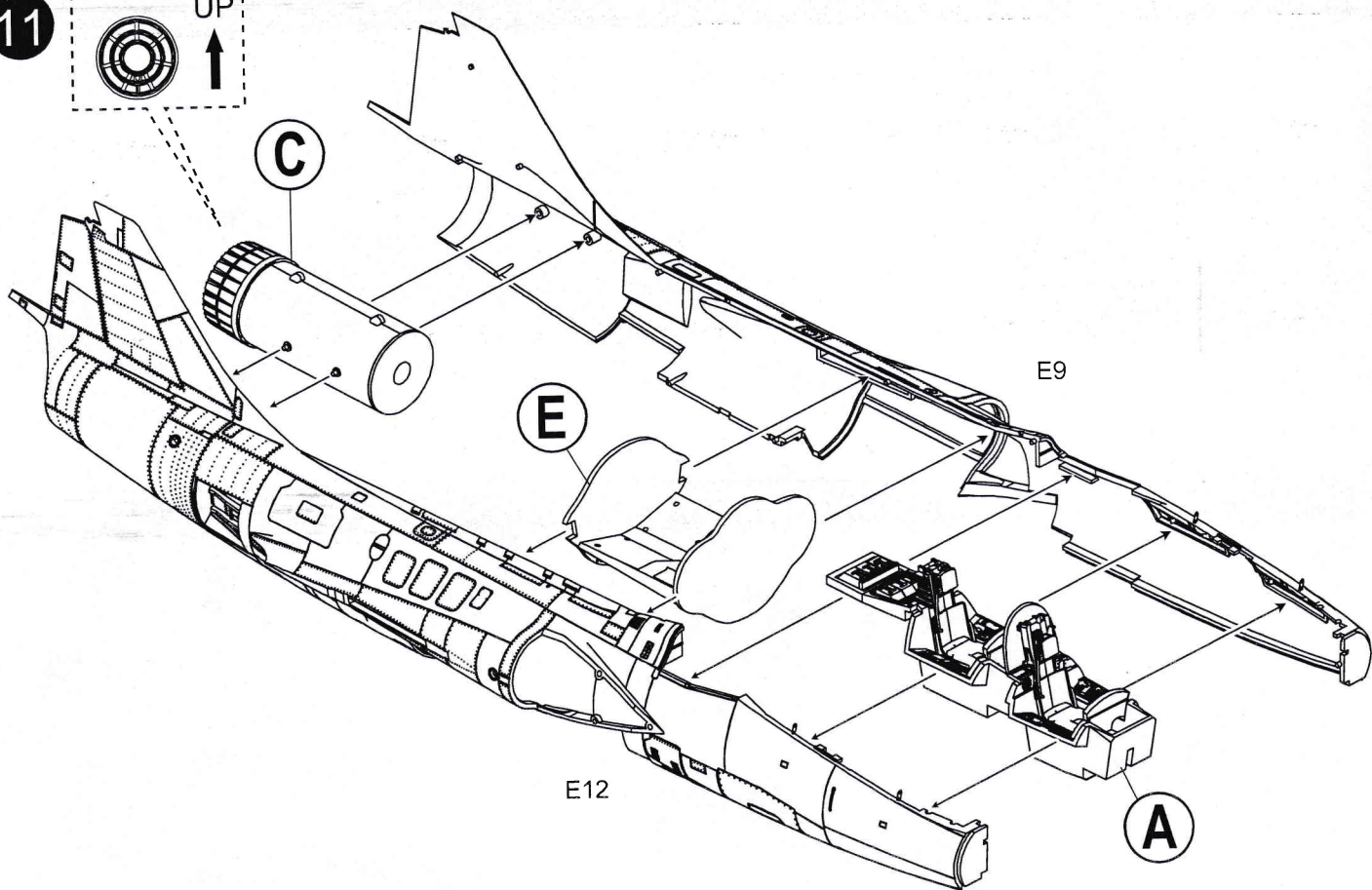

12

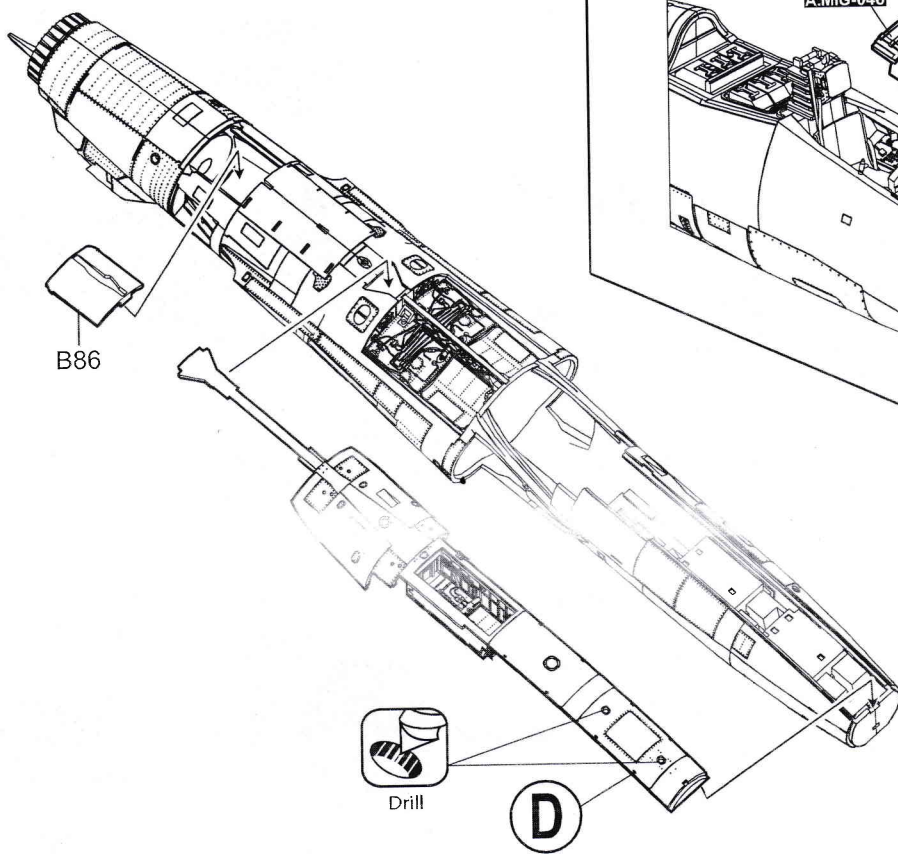

Focused View

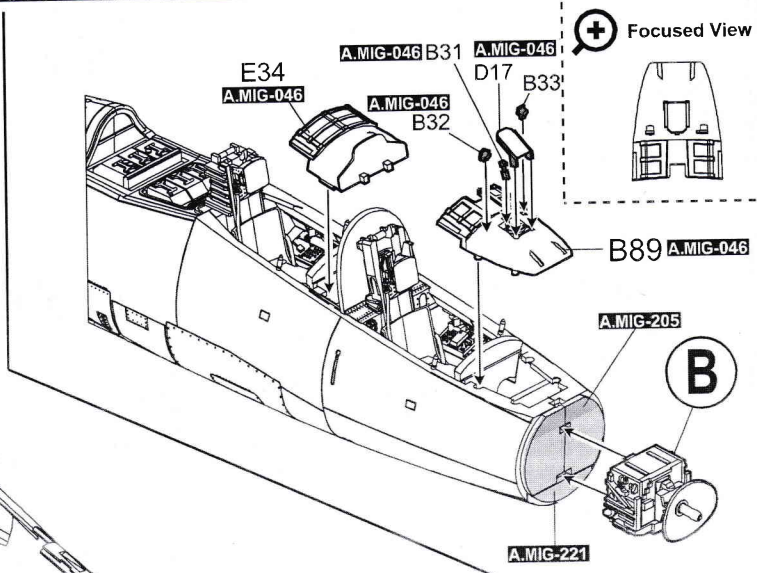

13

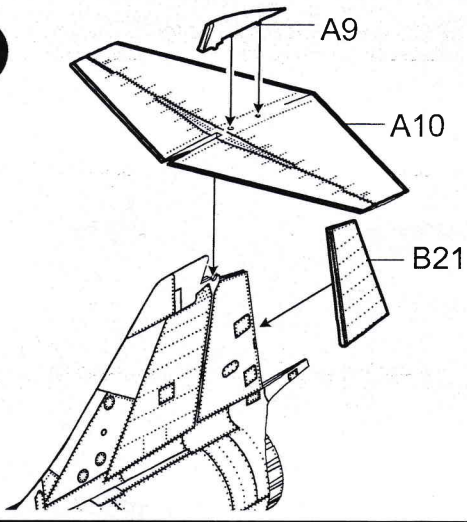

14

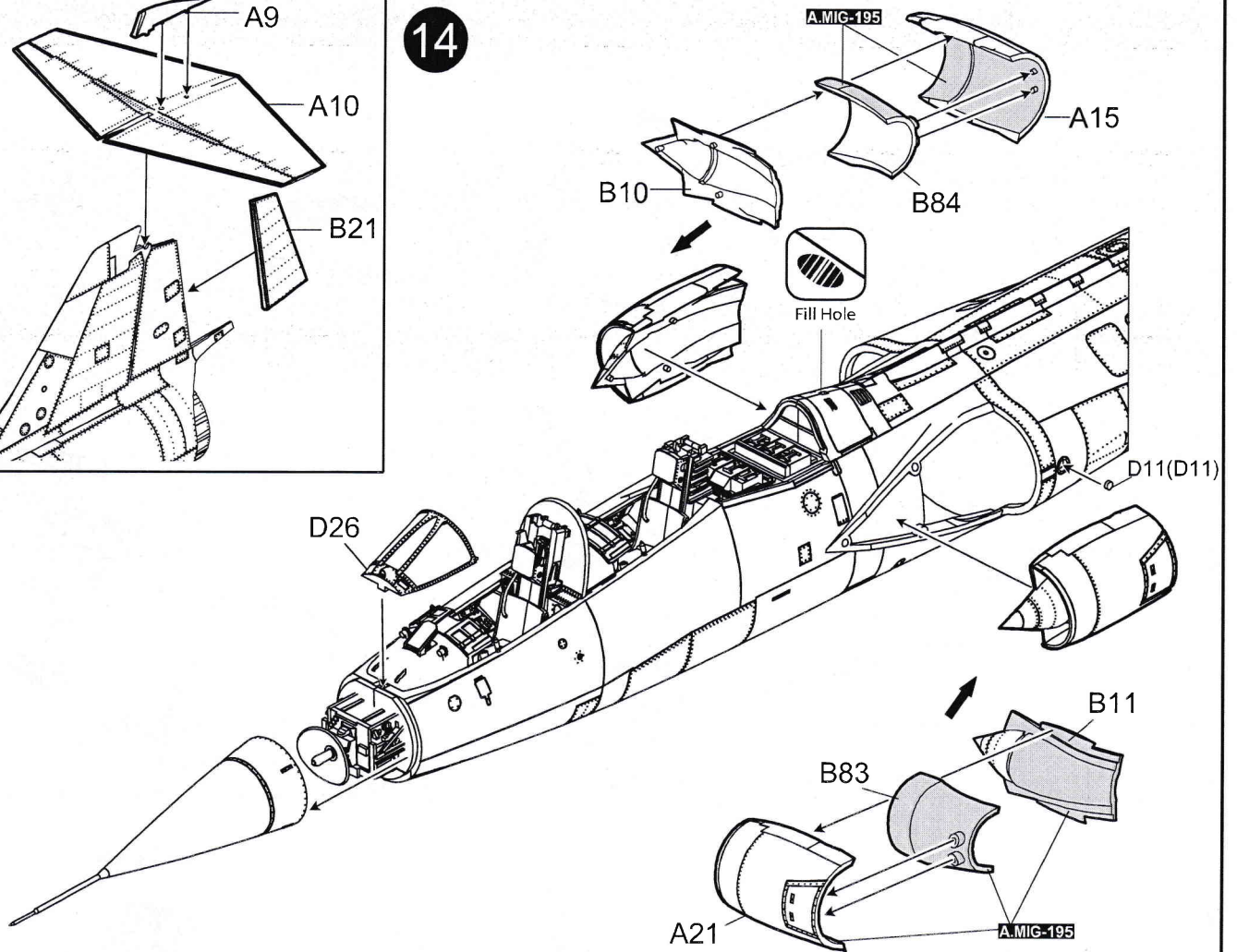

15

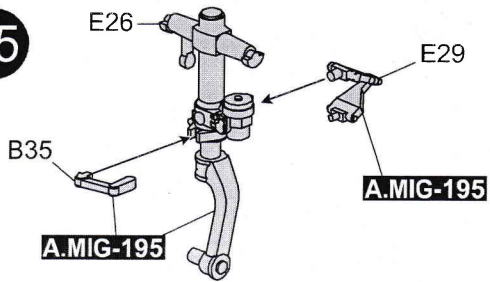

16

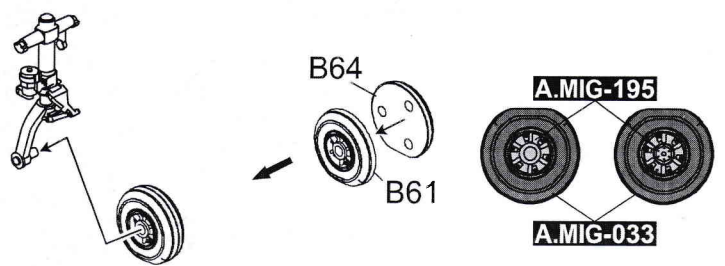

17

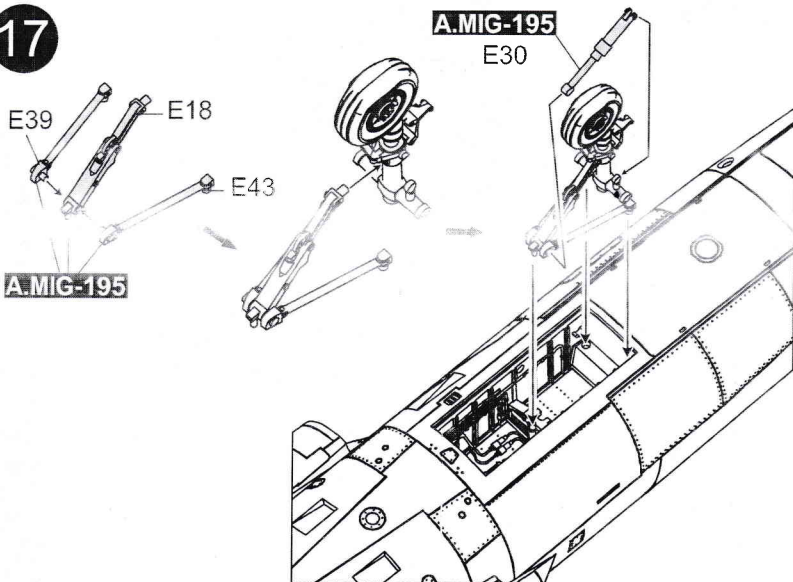

18

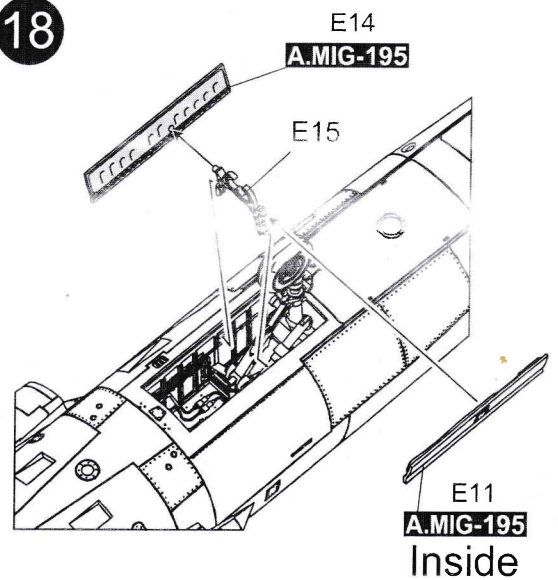

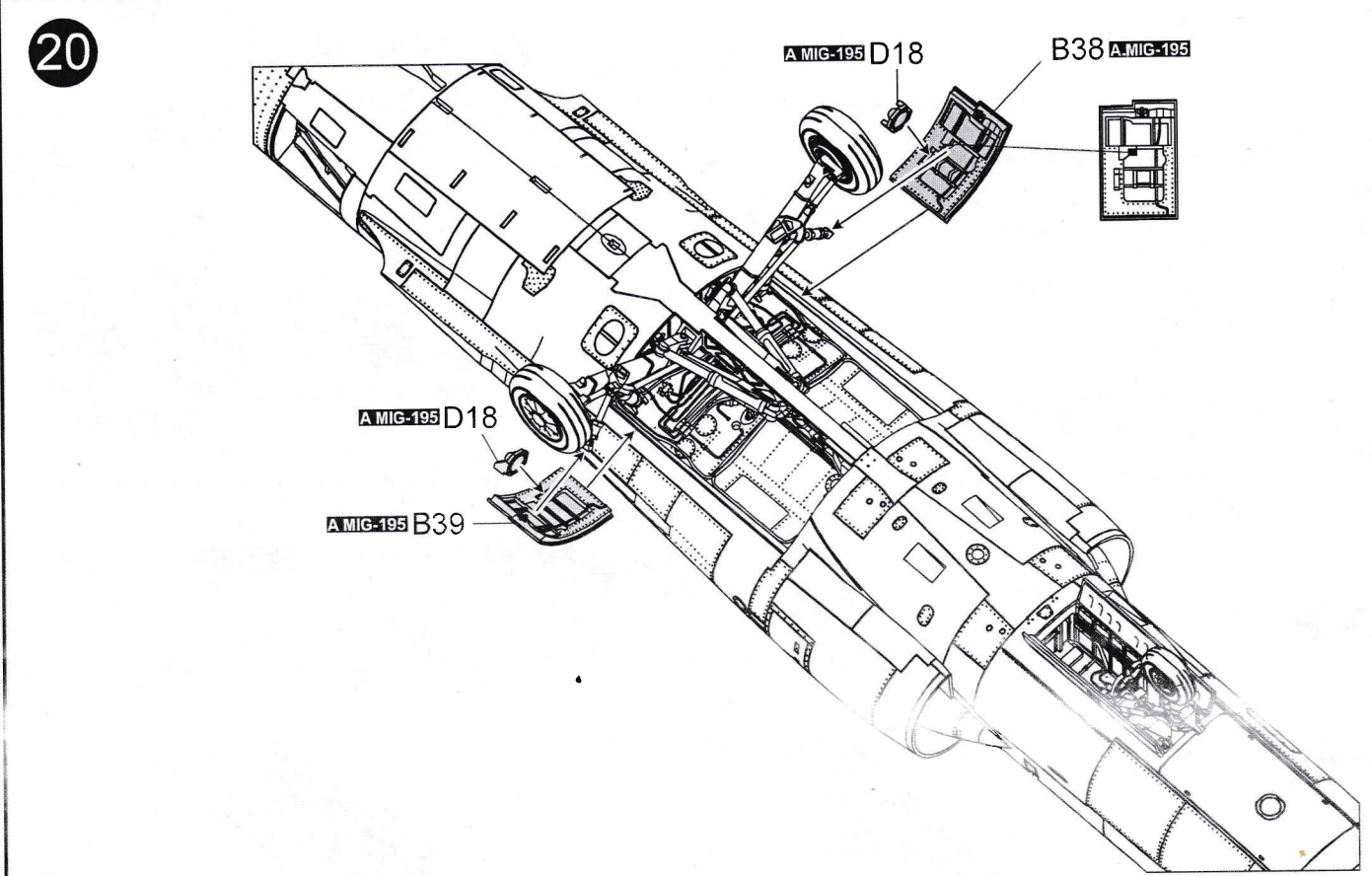
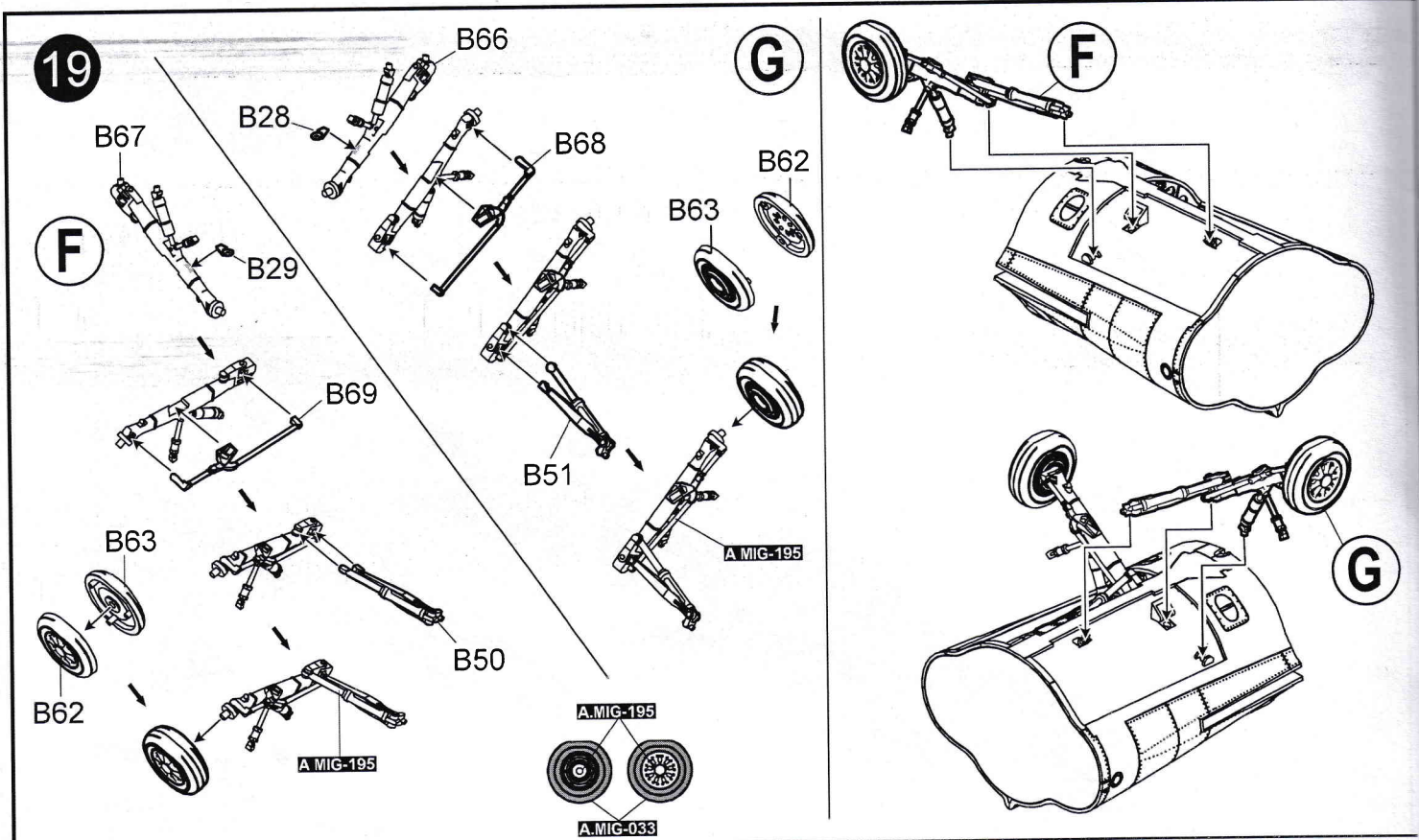



21

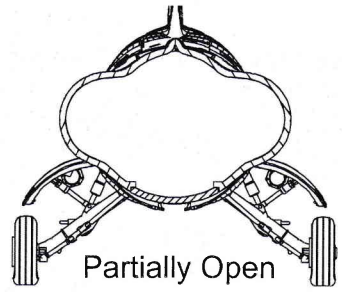
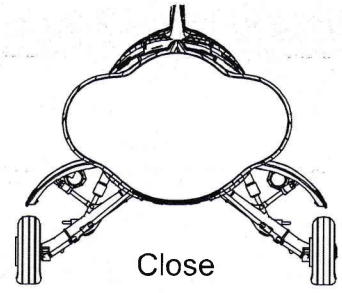
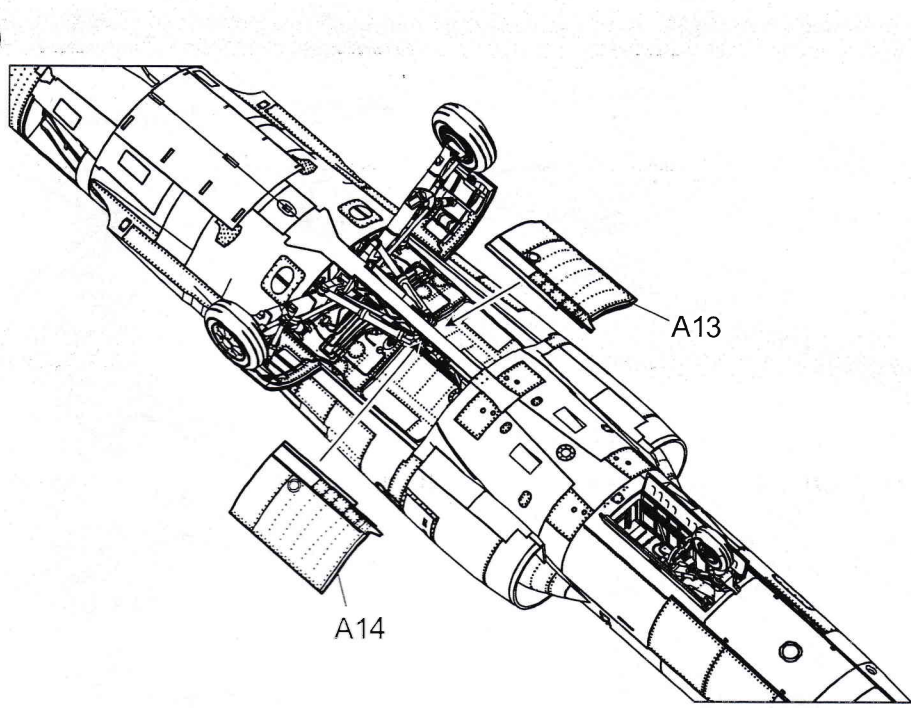

22

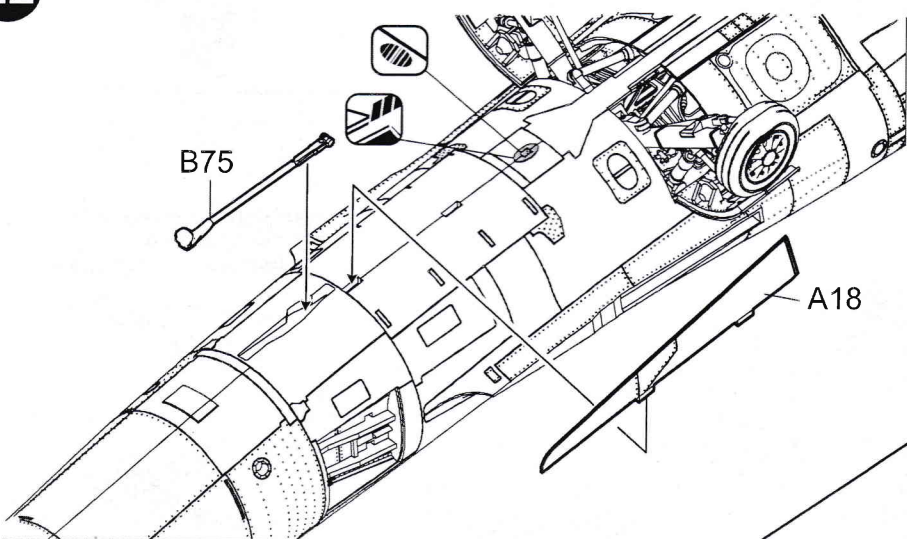

23

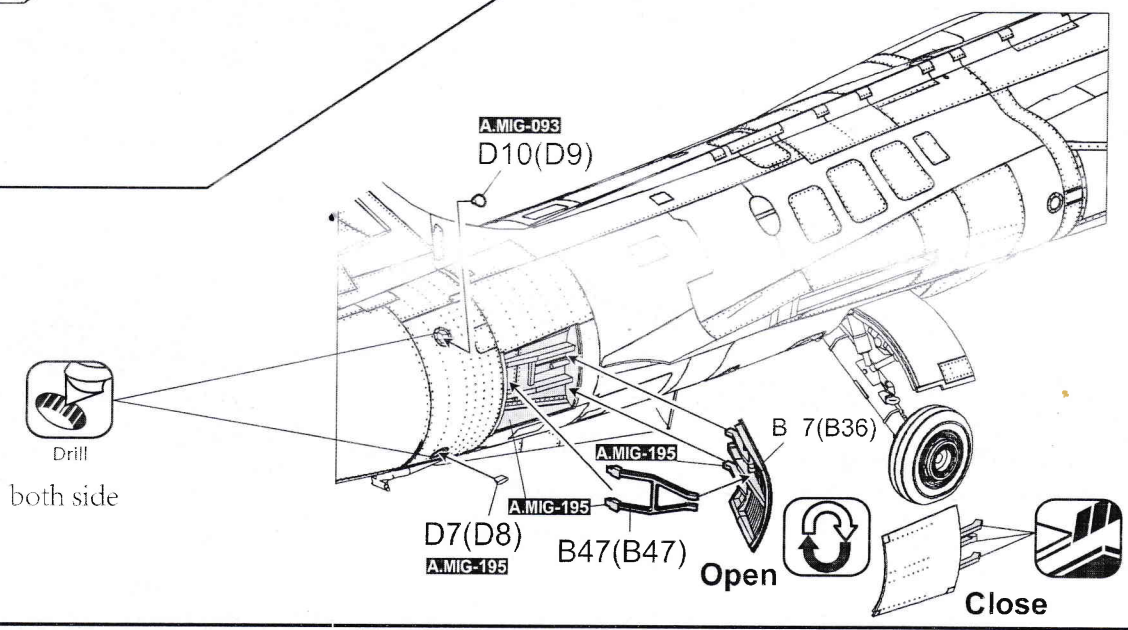

24

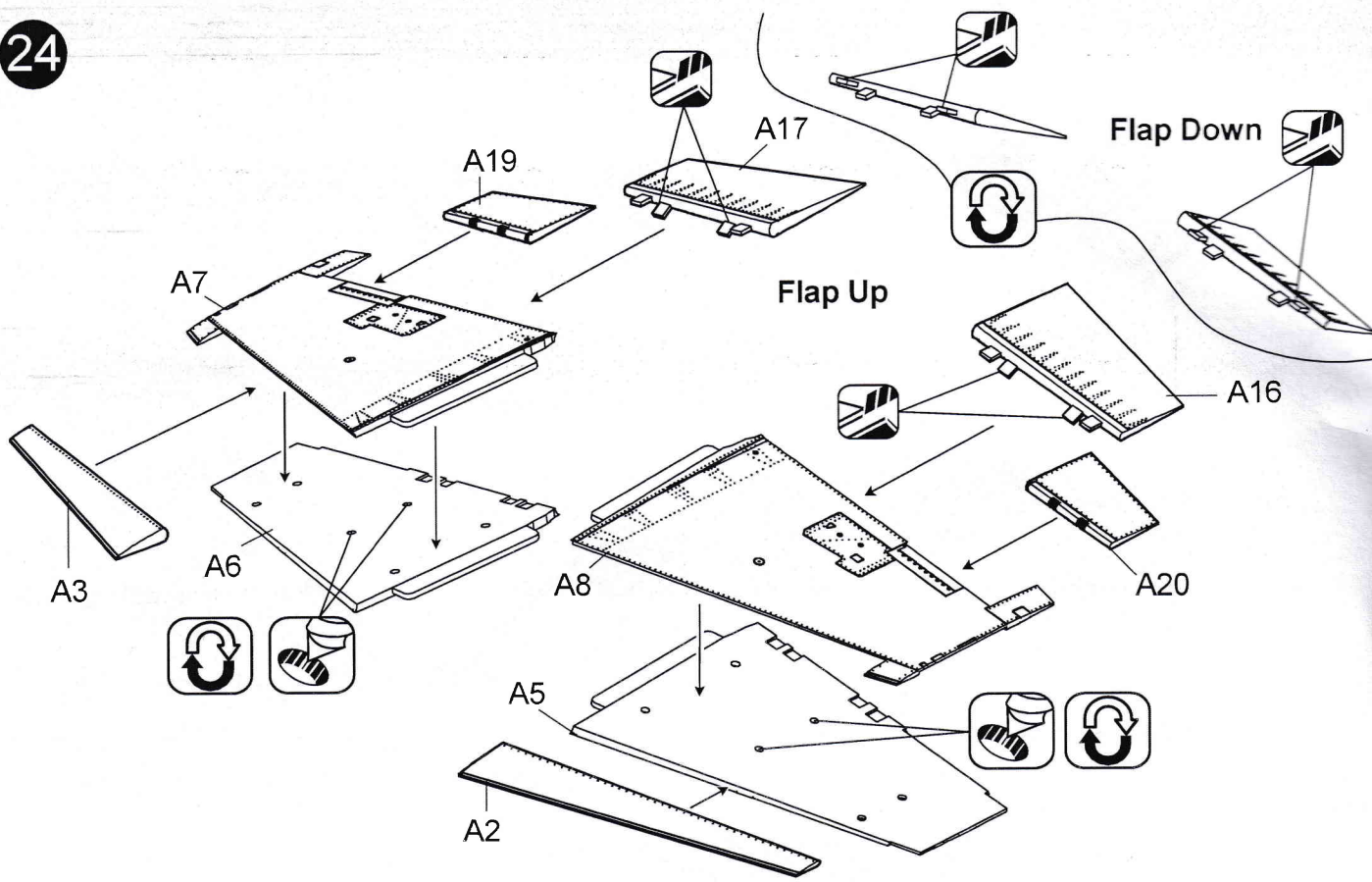

25

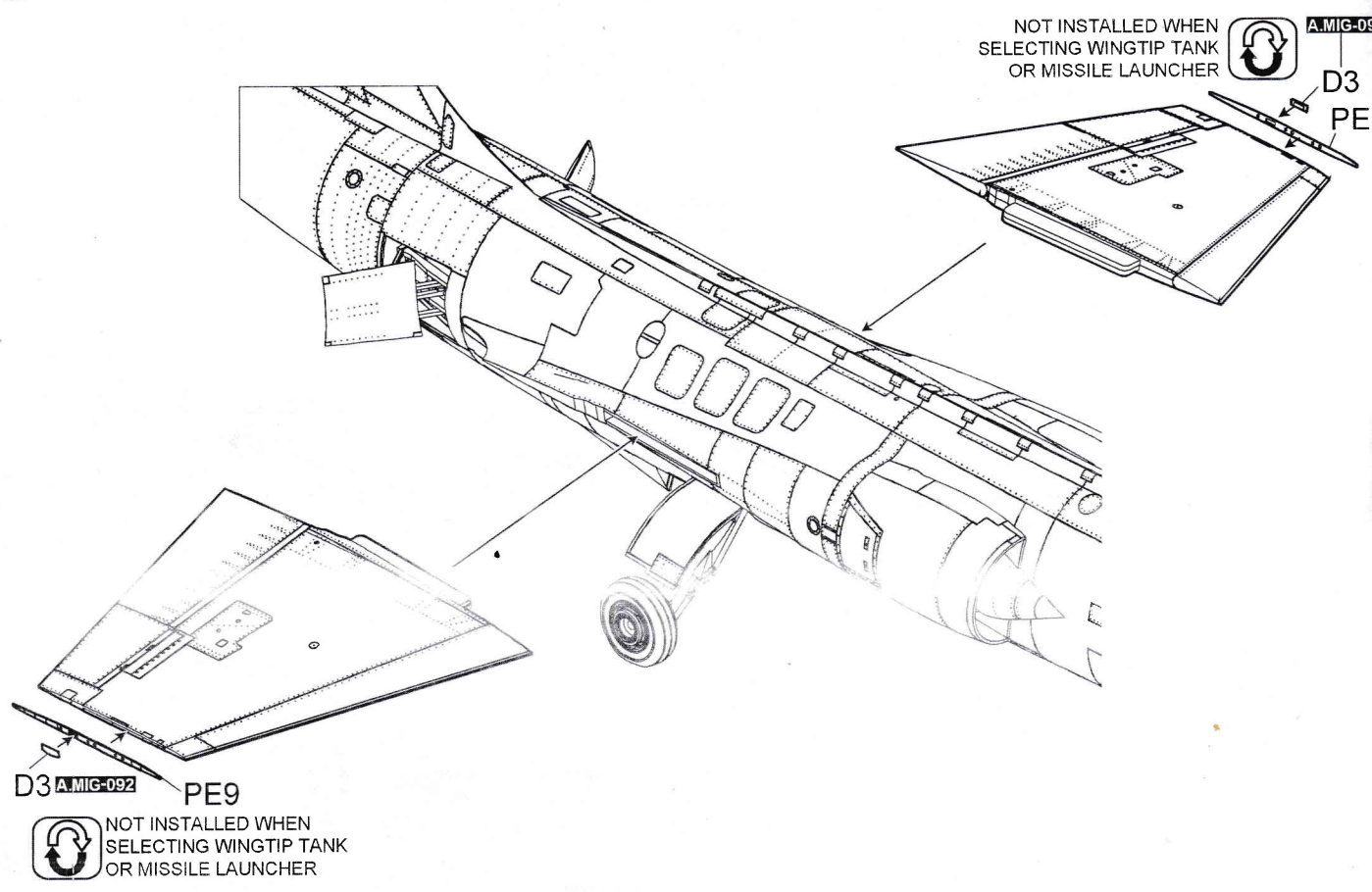

26

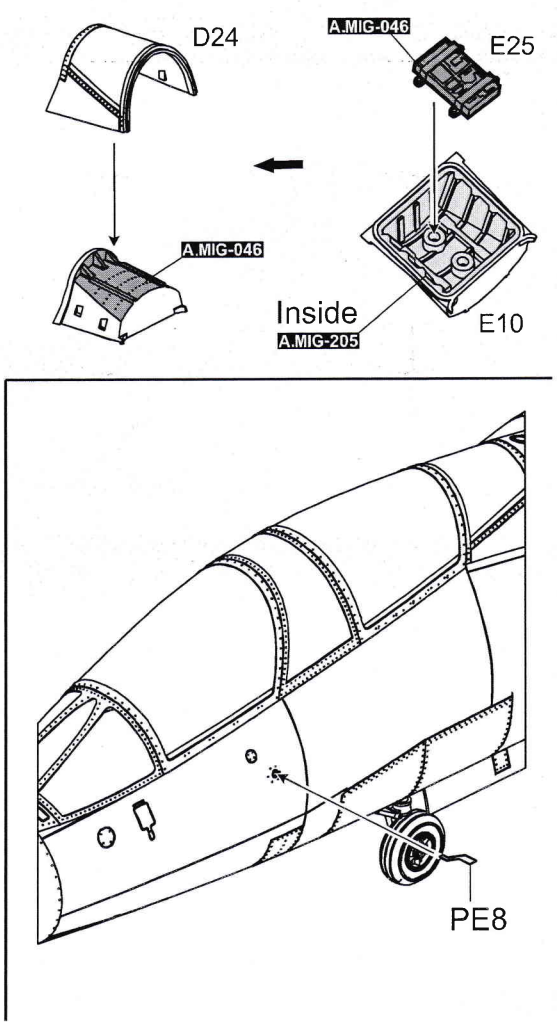
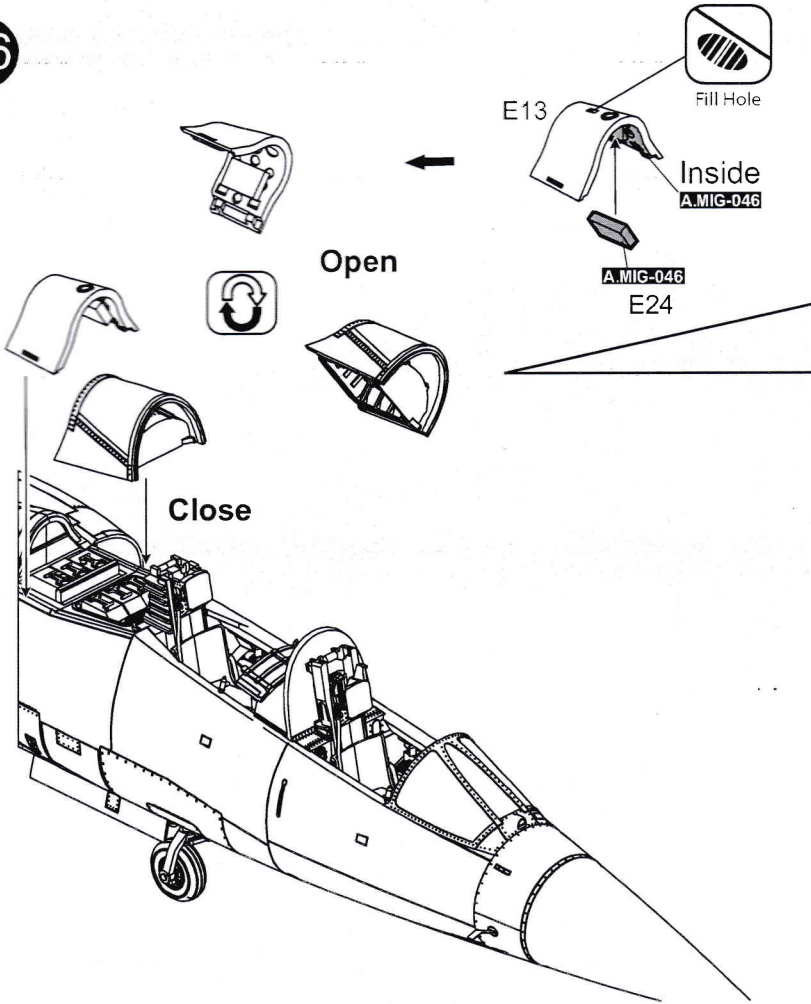

27

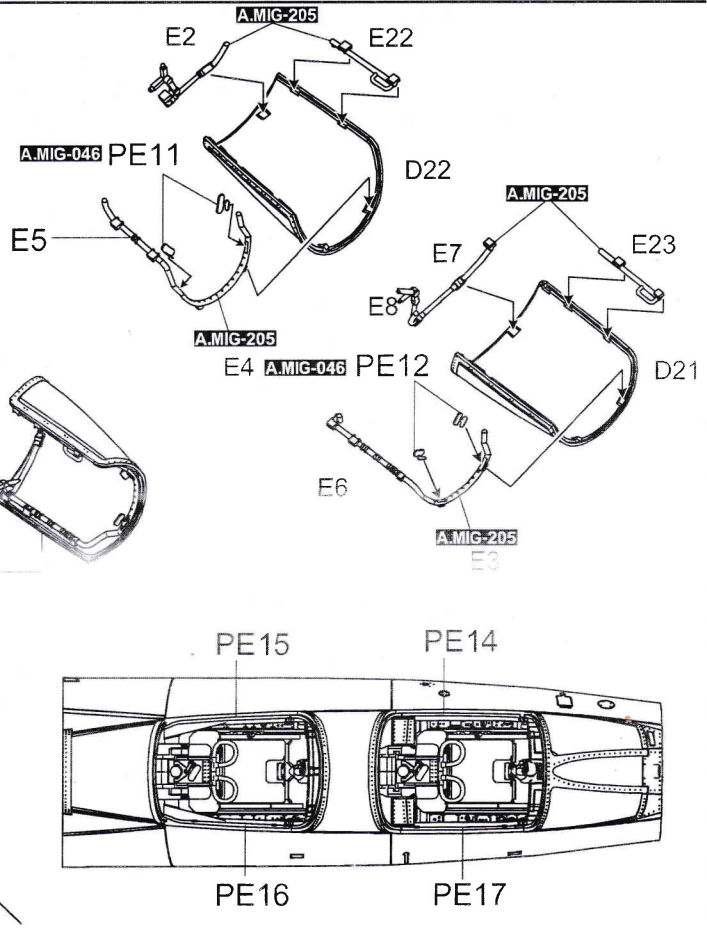
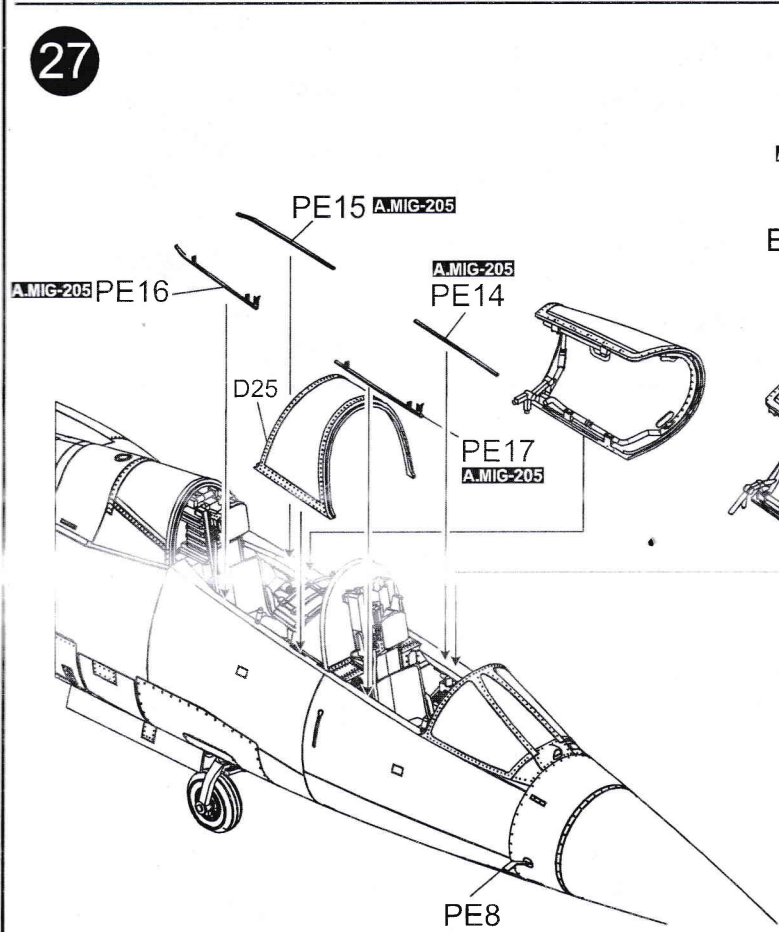

28

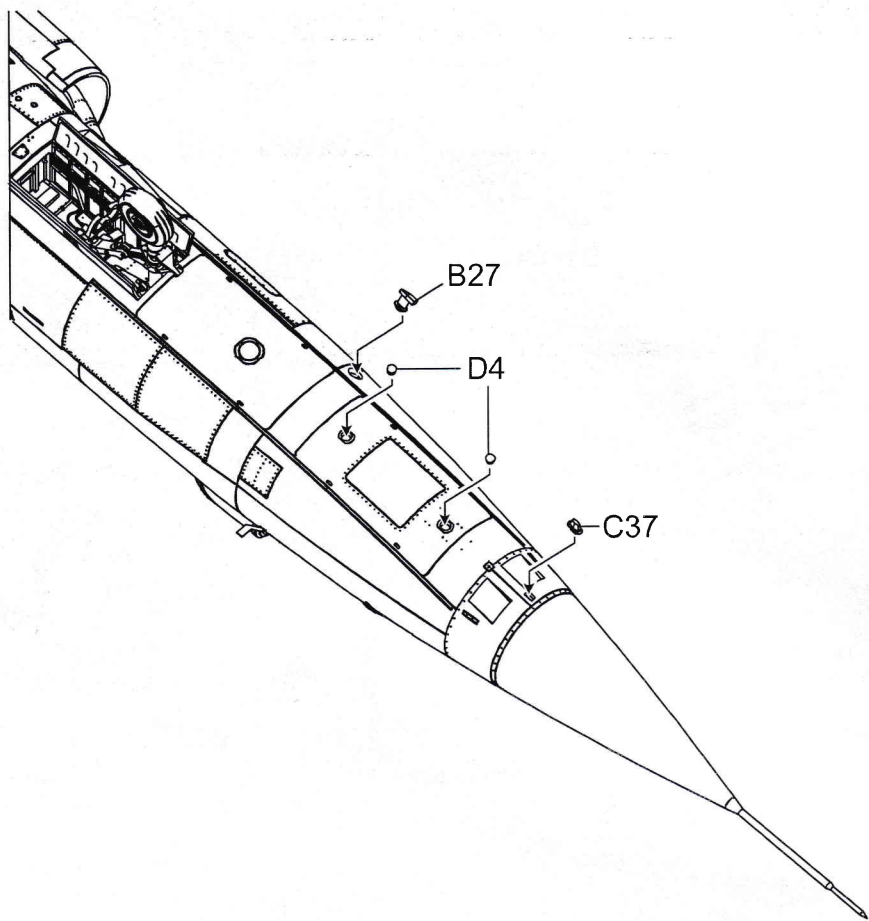

29

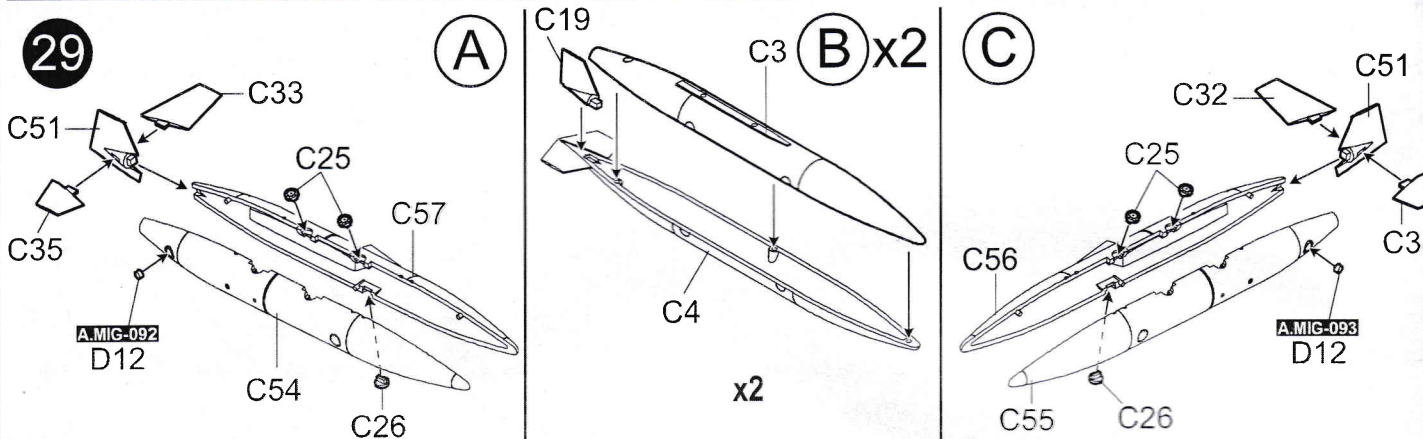

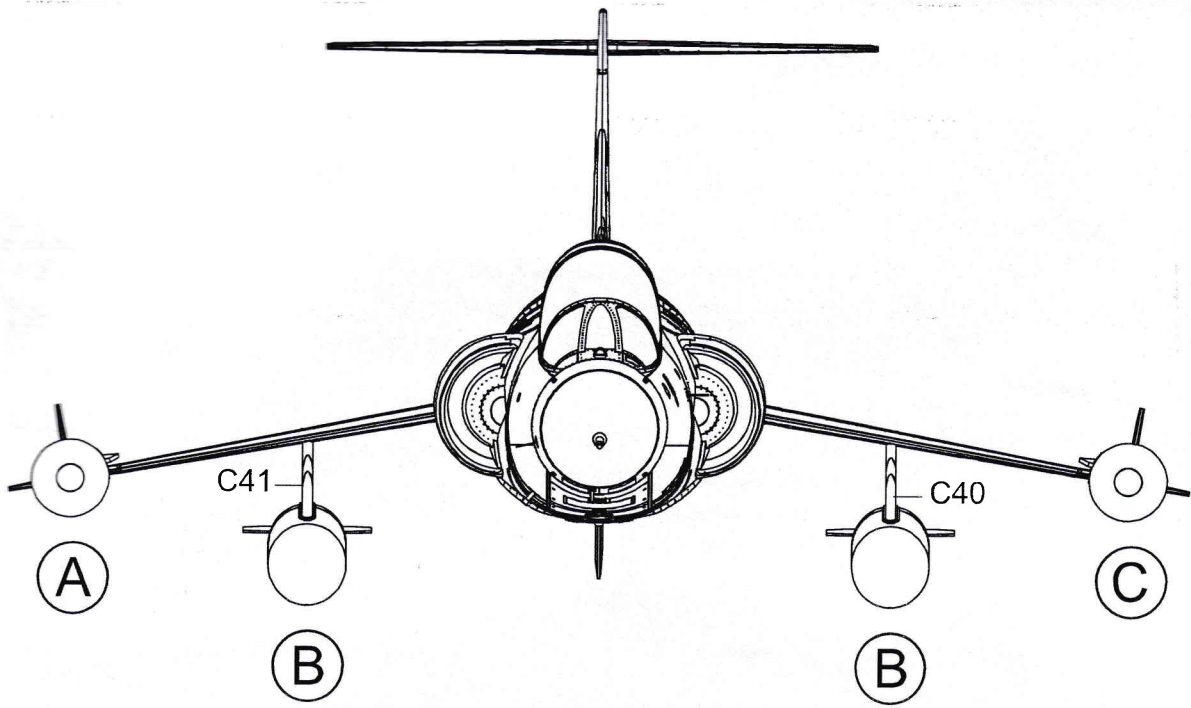

**1/48 SCALE AIRCRAFT SERIES NO. K48095**

CF-104D.s/n 104651.417 Sqn CFB Cold Lake ca.1975

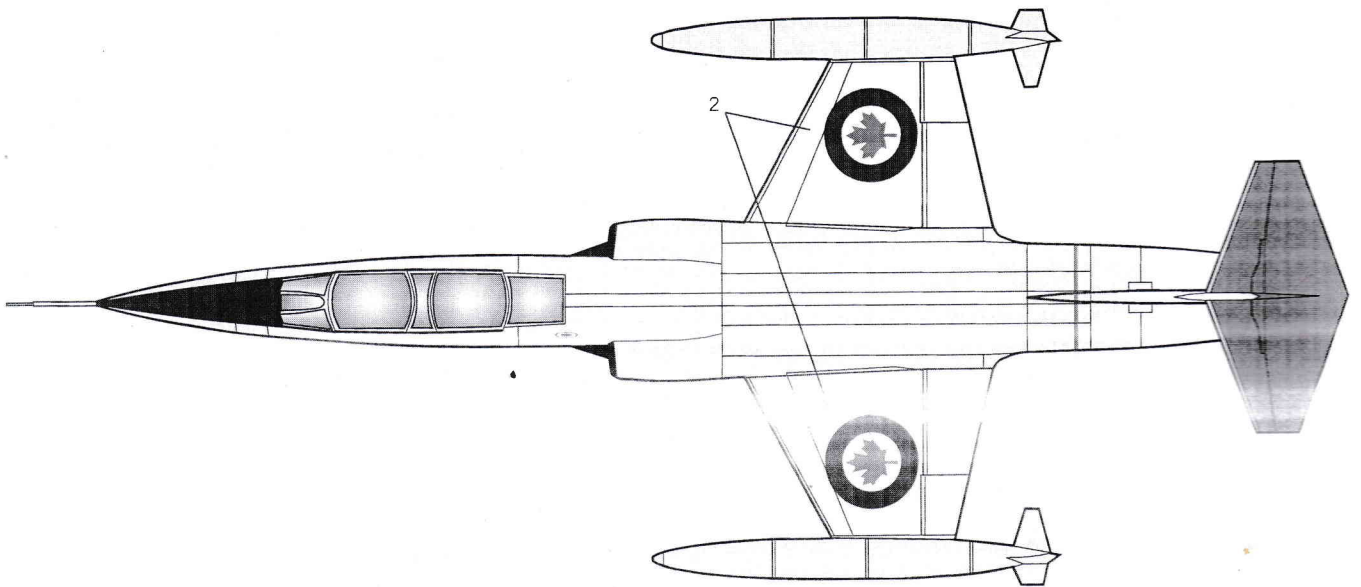
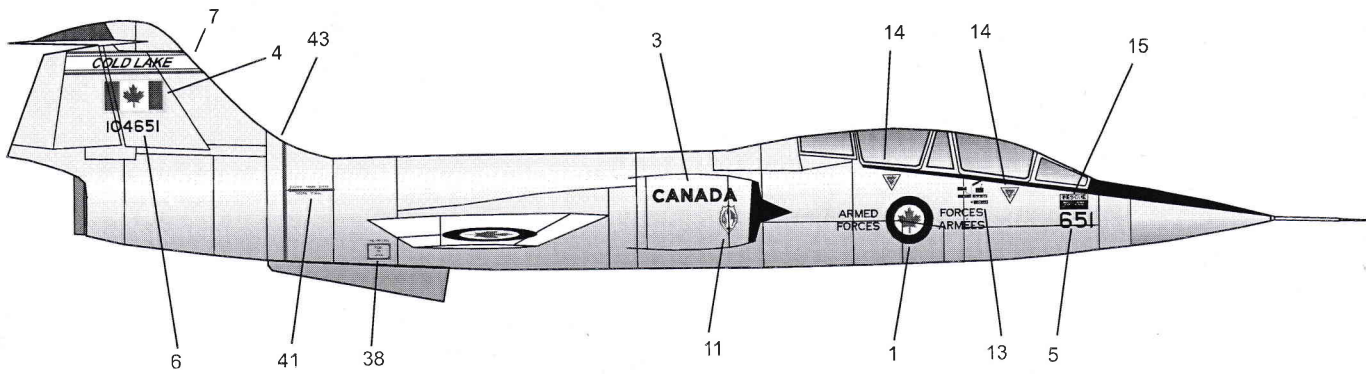
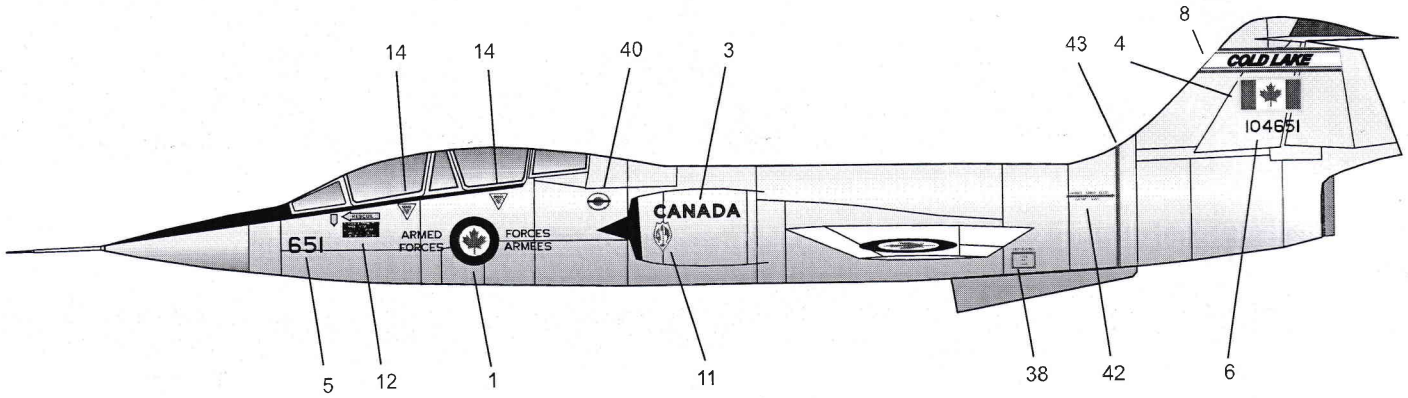

**A.MIG-8205**

**A.MIG-212** on wing bottoms & radome

**A.MIG-049**

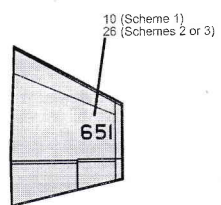
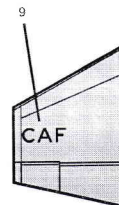

CF-104D.s/n 104653.439 Sqn. Tiger Meet in Bitburg.Germany.1974

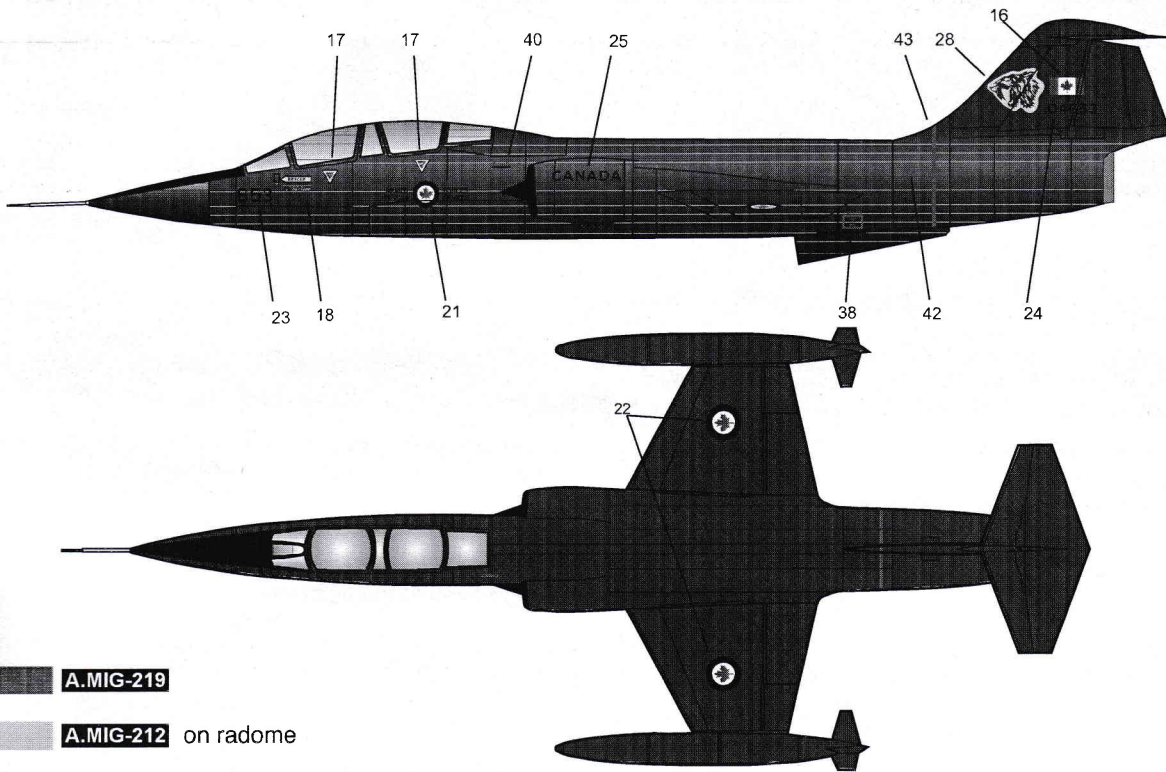

CF-104D.s/n 104653.439 Sqn.CFBLahr.1979

