



21001F1 1/200 BISMARCK 1941 ADVANCED Add-on SET
27001F1 1/200 BISMARCK 1941 ADVANCED SET

< Contents >

1. Wooden deck : 1 Set (27001F1 Only)
2. Scribed Brass : 106 Pcs.(21001F1) / 318Pcs.(27001F1)
3. Photo Etching : 5 Sheets(21001F1) / 15Sheets.(27001F1)
4. Resin Parts : 5Pcs.(21001F1) / 27Pcs.(27001F1)
5. Life Tubes : 25 Pcs(27001F1 Only)
6. Dry Transfer : 1 Sheet(27001F1 Only)

59. Cart part 1 : 8Pcs.
60. Cart part 2 : 8Pcs.
61. Funnel Pipe A : 15Pcs.
62. Funnel Pipe B : 19Pcs.
63. Funnel Pipe C : 13Pcs.
64. Bitt C/D : 15Pcs.
65. Bitt E : 4Pcs.
66. Paravane Boom A : 4Pcs.
67. Paravane Boom B : 4Pcs.
68. Paravane Boom C : 8Pcs.
69. Paravane : 8Pcs.

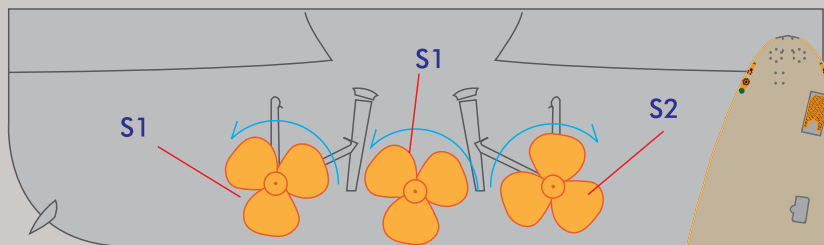

<Brass Screws>



<Paravane : 8 sets>

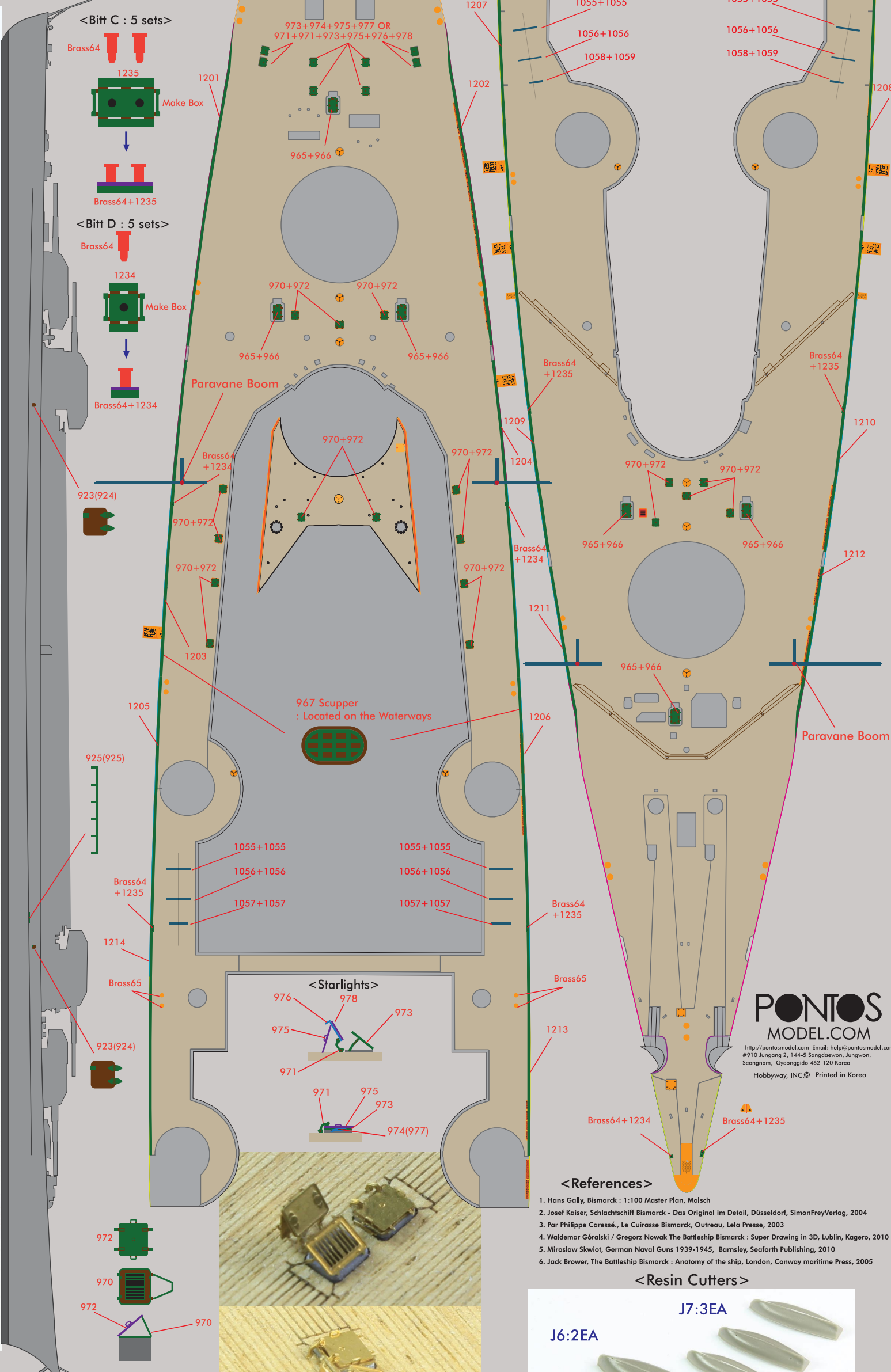
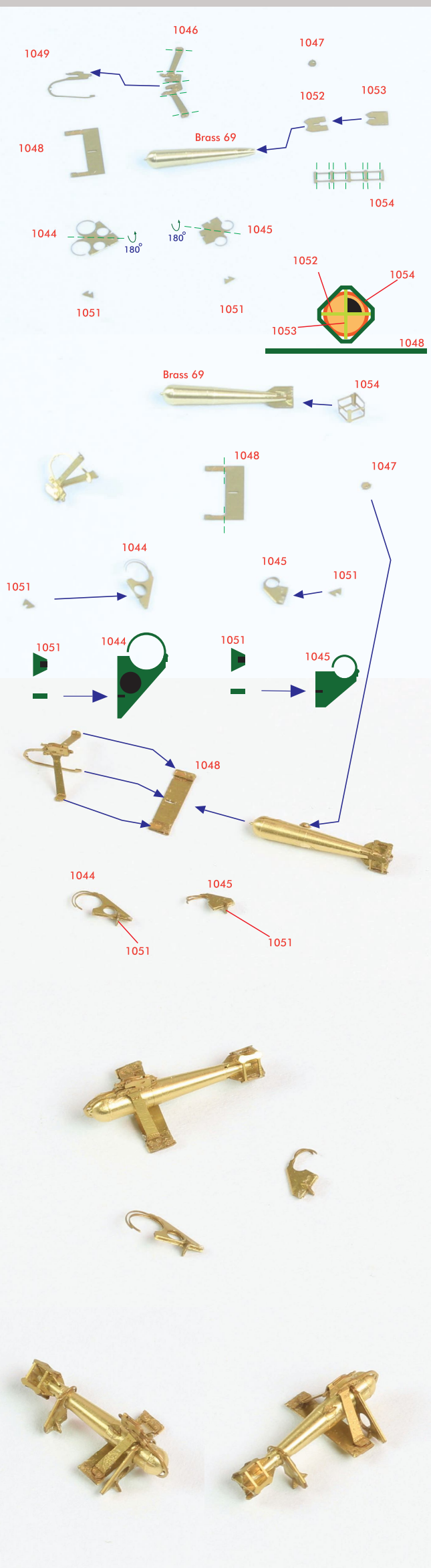

PONTOS MODEL.COM
 http://pontosmodel.com Email: help@pontosmodel.com
 #910 Jungang 2, 144-5 Sangdoewon, Jungwon, Seongnam, Gyeonggido 462-120 Korea
 Hobbyway, INC. Printed in Korea

<References>

1. Hans Gally, Bismarck : 1:100 Master Plan, Malsch
2. Josef Kaiser, Schlachtschiff Bismarck - Das Original im Detail, Düsseldorf, SimonFreyVerlag, 2004
3. Par Philippe Caressé., Le Cuirasse Bismarck, Outreau, Lela Presse, 2003
4. Waldemar Góralski / Gregorz Nowak The Battleship Bismarck : Super Drawing in 3D, Lublin, Kagero, 2010
5. Mirosław Skwiot, German Naval Guns 1939-1945., Barnsley, Seaforth Publishing, 2010
6. Jack Brower, The Battleship Bismarck : Anatomy of the ship, London, Conway maritime Press, 2005

<Resin Cutters>



For better information or corrections, we update this manual on our website.
 Pontosmodel makes every effort to see to it that our customers are satisfied. If you have product suggestions or if there is a particular product of dry transfer you would like to suggest we carry, please feel free to contact us.

<Paravane Boom : 2+2 sets>

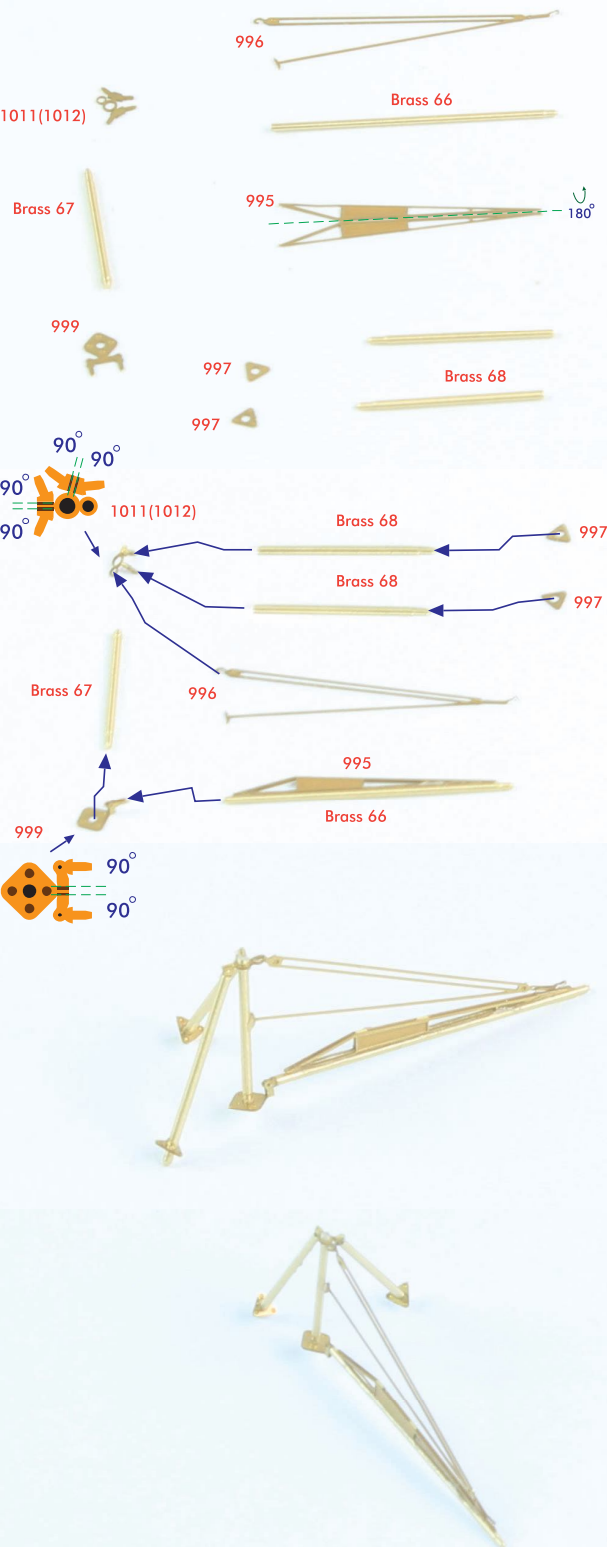

<Vent Louvres>

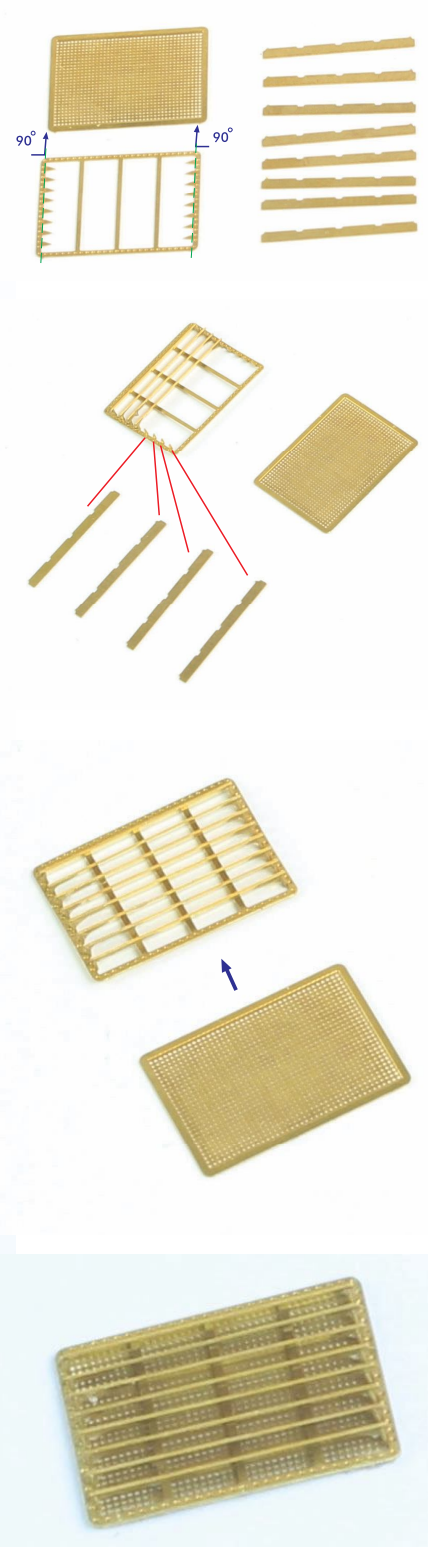

<Funnel Pipes>

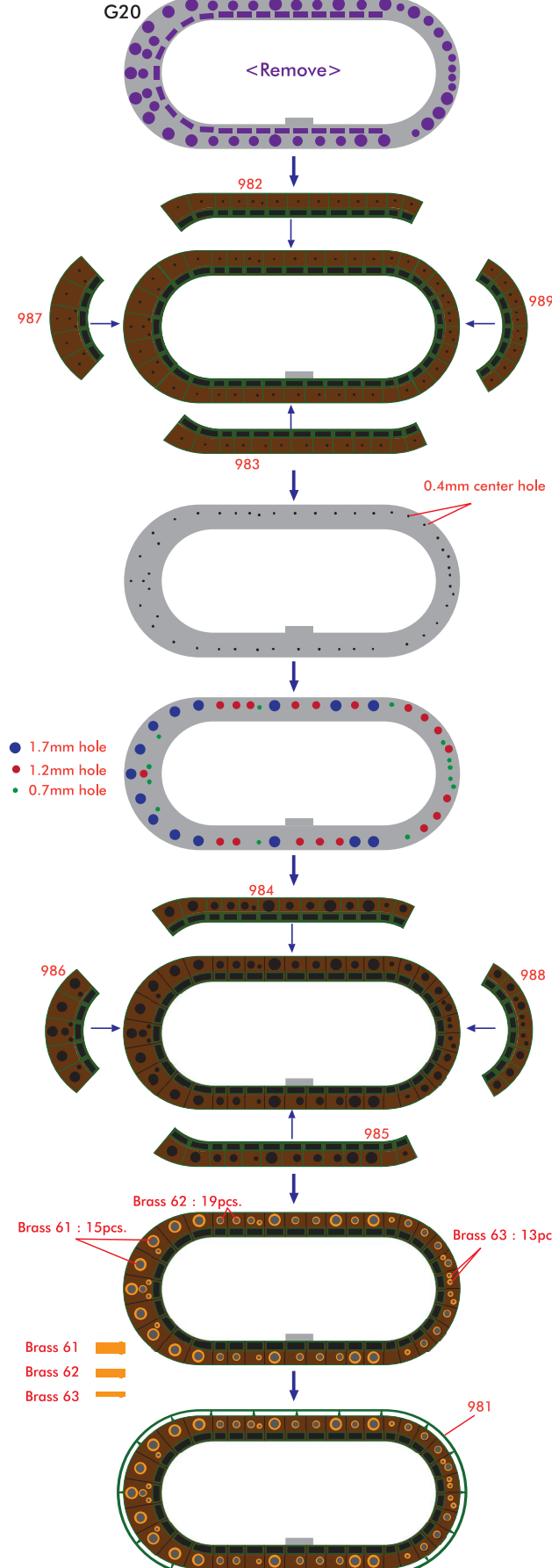

<Resin 8m Cutter J6 : 2 sets>

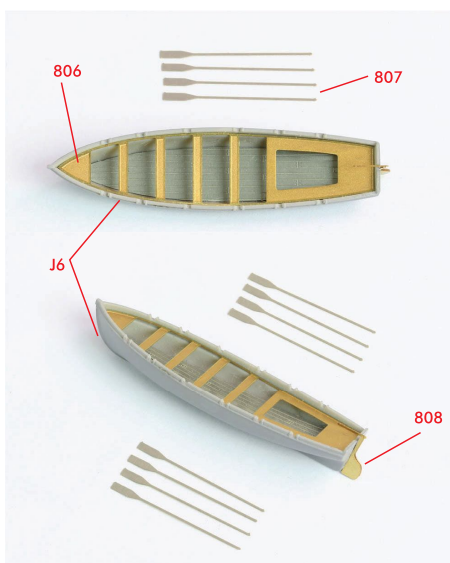

<Resin 6m Cutter J7 : 3 sets>

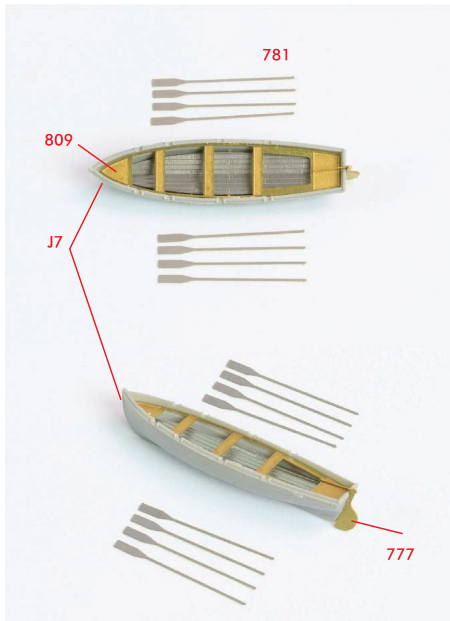

<Cart>

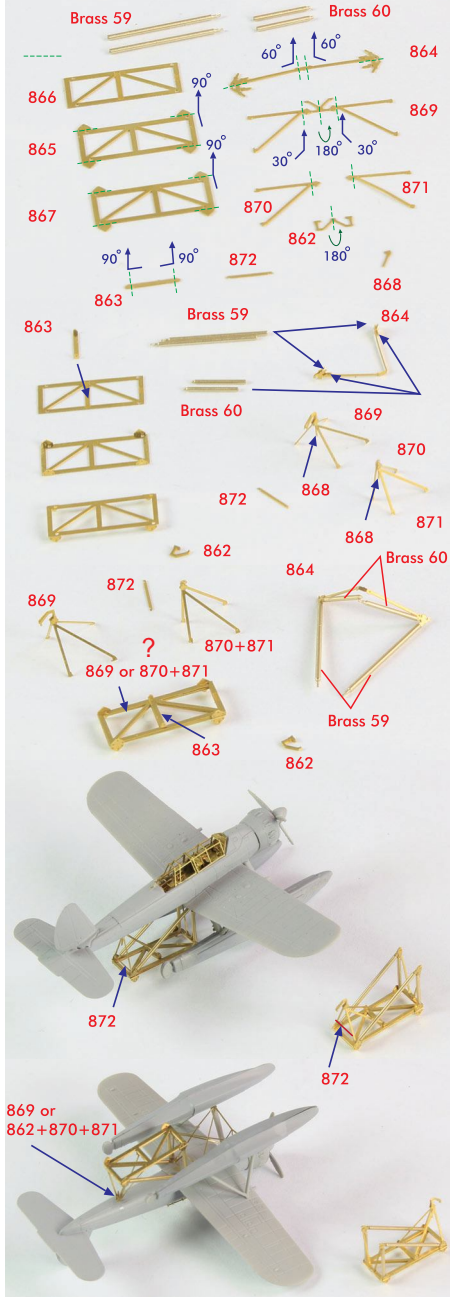

<Arado Hanger Rails>

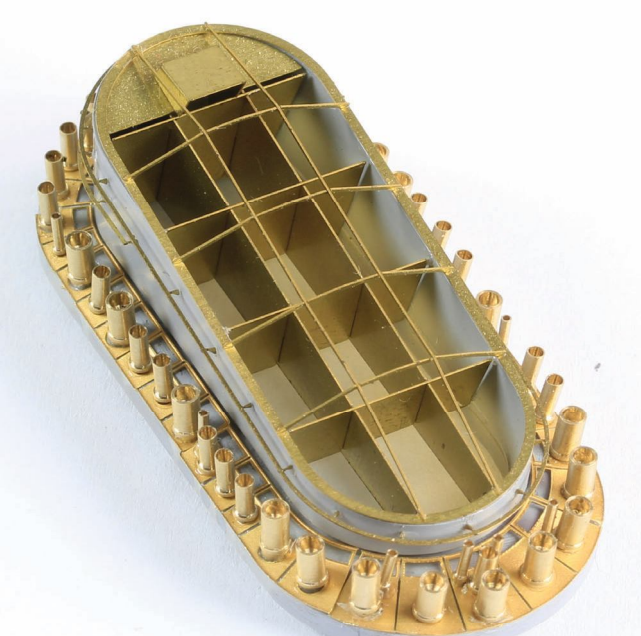
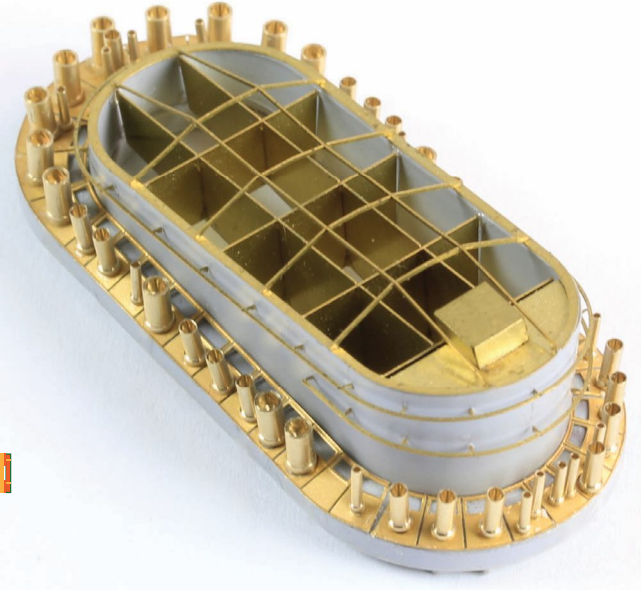
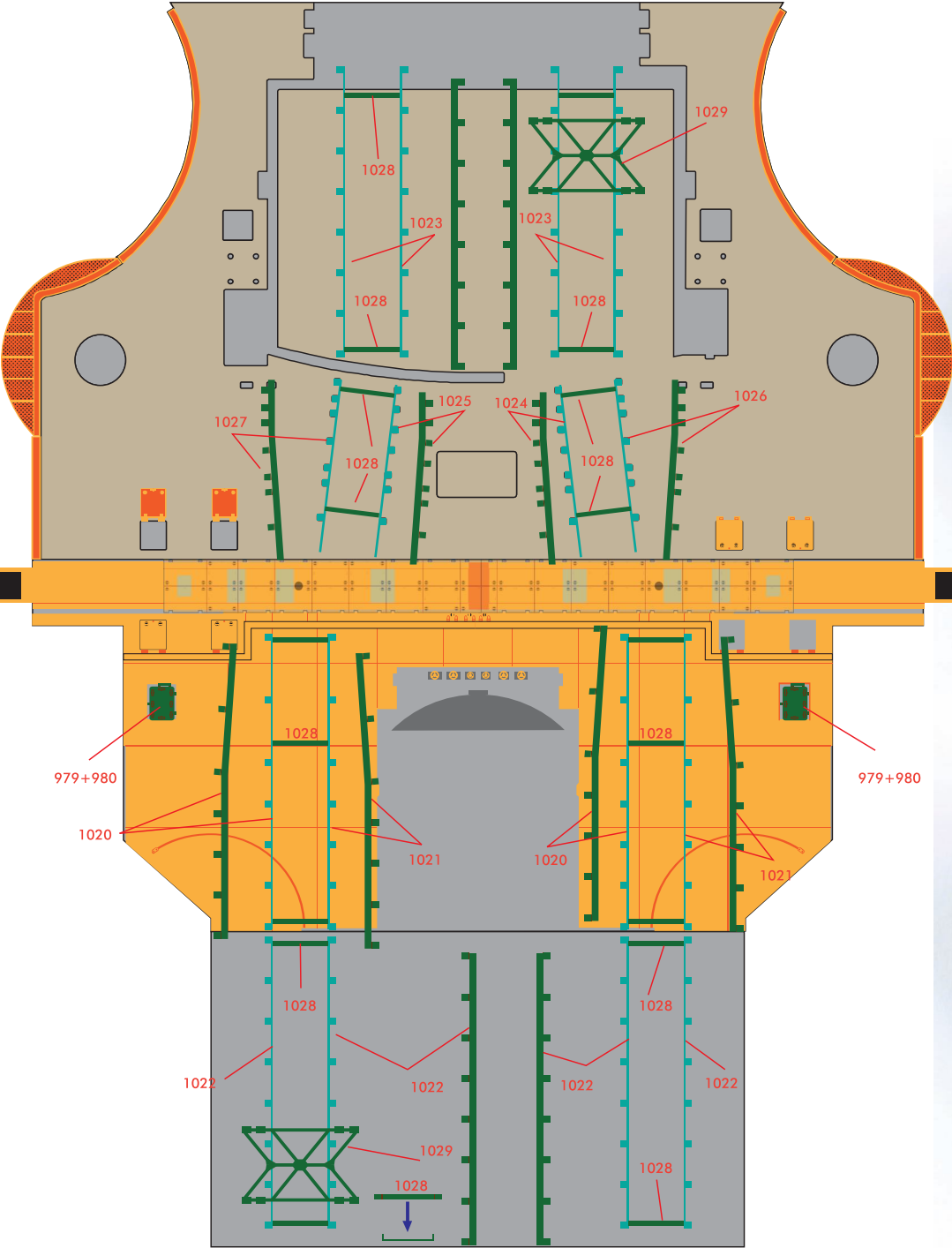

<Door of Searchlight Dome>

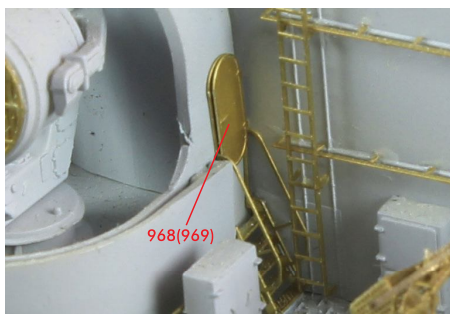

<Sd.Ah.51 Trailer>

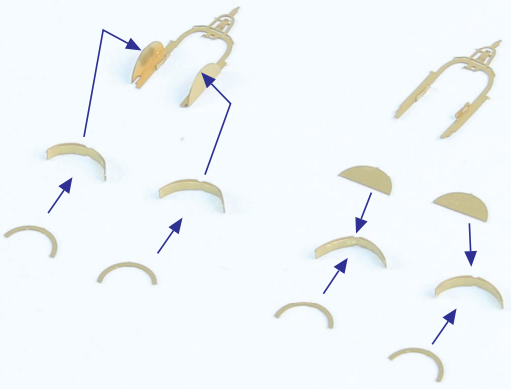
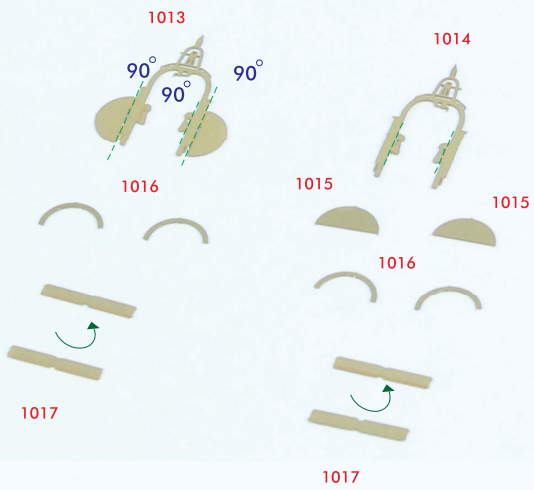

<Boat Crutches>

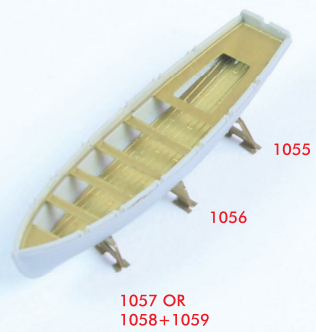
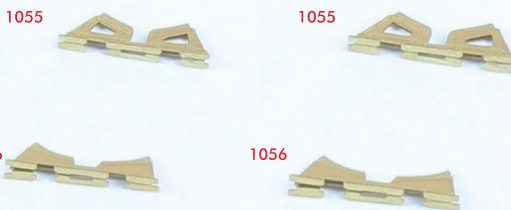
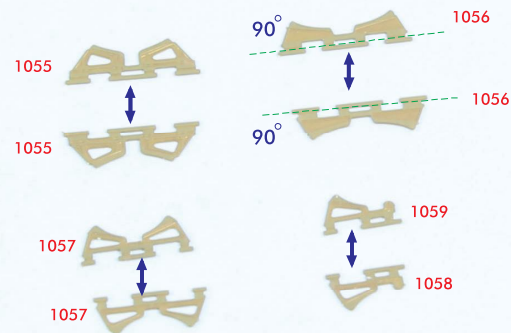

1057 OR 1058+1059

<Catapult Catwalks>

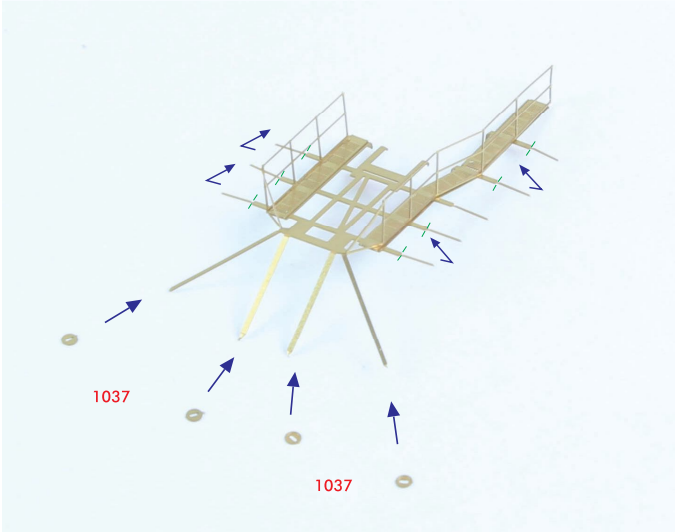
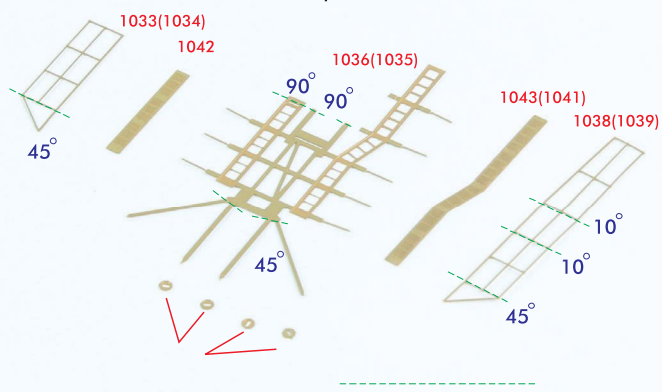

<Wire Stand on the Bow>

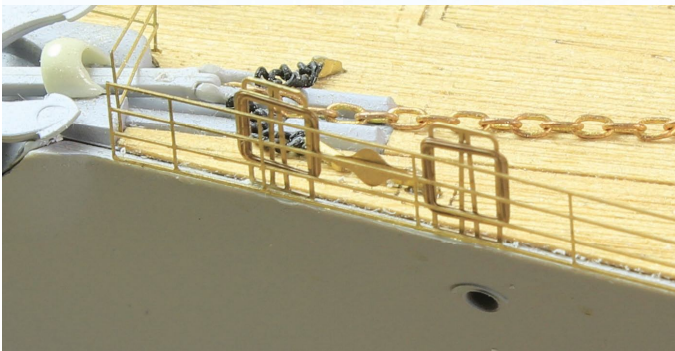
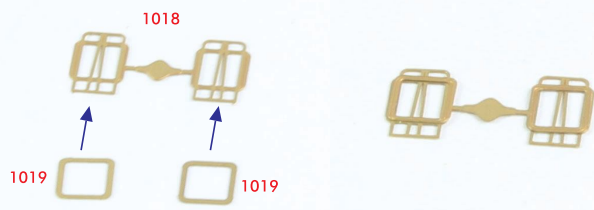

<Fire Hose>

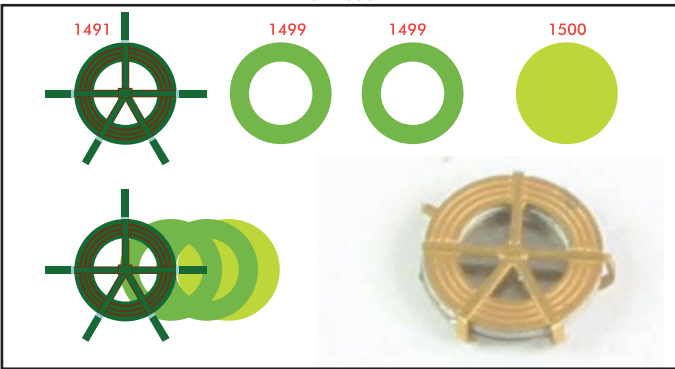

<Rigging Connectors>

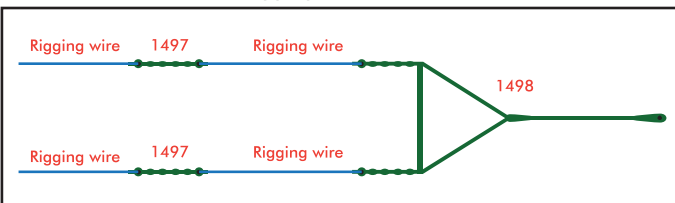

<Wire Rail>

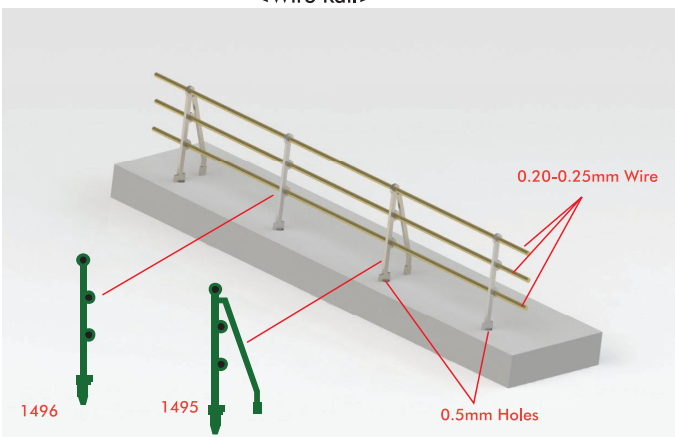

<Signal Light Guard Rails>

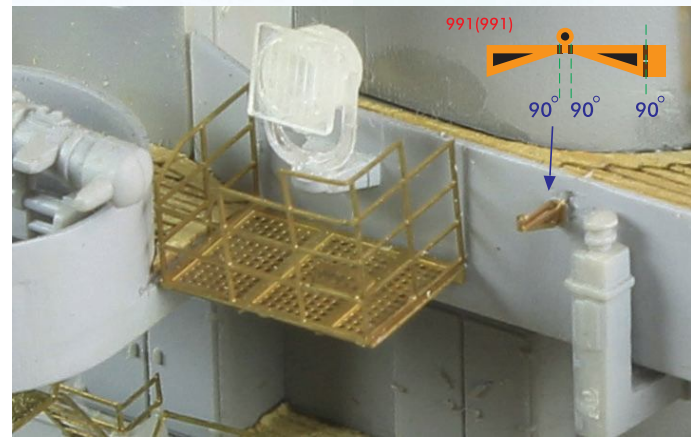
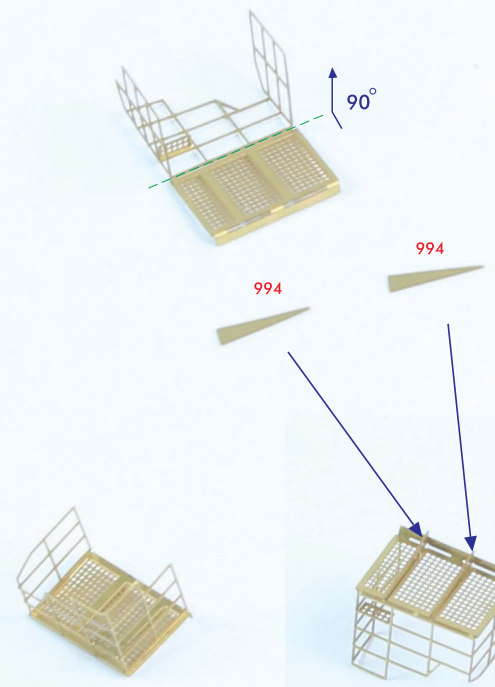
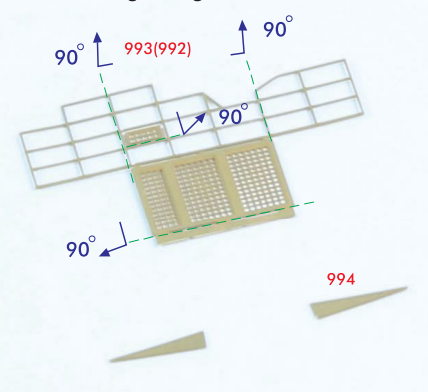

<Phone Booth :>

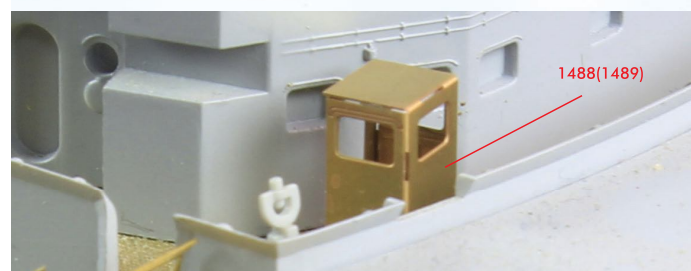
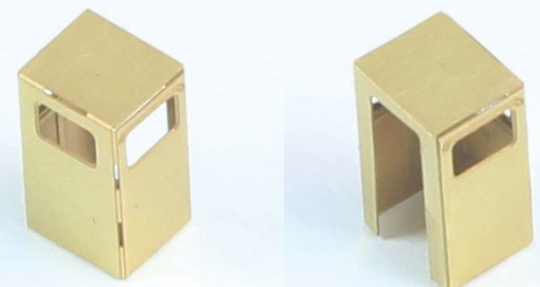
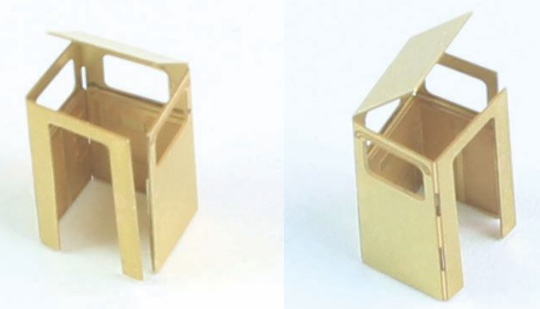
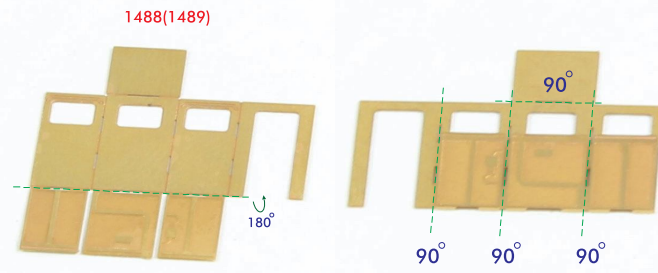

1488(1489)

