

Revell MIL-28 Havoc

KIT 4042

1/72 SCALE 1/72 ECHELLE ESCALA 1/72

REVELL, INC. Des Plaines, IL Copyright © 1991 All rights reserved. Printed in U.S.A.

4042 R 4200

The Mil-28 HAVOC is a two-man attack helicopter with heavy armament, but altogether slimmer and less vulnerable than its better known brother, the Mil-24 Hind. The Mil-28 HAVOC ends up being very similar to the U.S. Apache. It features the familiar undernose gun turret and weapon-carrying stub wings. The nose gun is controlled by the head set of the forward pilot. The armaments on the stub wings consist of 18 rocket pods and 8 "Spiral" missiles per side.

The Mil-28 HAVOC was first introduced to the public at the 1989 Paris Air show and attracted a lot of attention. The HAVOC has two ISOTOV TV3-117 turboshaft engines which powers a twin-stacked rotor system, one on top of the other. This system gives the HAVOC a top speed of 186 mph and a combat radius of 149 miles. This 1/72nd scale replica features a detailed two-place cockpit and pivoting automatic machine gun located under the nose. An optical laser designator is positioned under the nose and the external armament mounts are fitted with external rocket pods and antitank missiles. All in all, this replica is a fine example of this advanced Soviet helicopter.

READ THIS BEFORE YOU BEGIN

- Study the assembly drawings.
- Each plastic part is identified by a number.
- Check the fit of each piece before cementing in place.
- Do not use too much cement to join parts.
- Use only cement for polystyrene plastic.
- Model may be painted to match photos on box.
- Allow paint to dry thoroughly before handling parts.
- Scrape paint from areas to be cemented.
- For better paint and decal adhesion, wash the plastic parts in a mild detergent solution. Rinse and let air dry.

LISEZ CE QUI SUIT AVANT DE COMMENCER

LE MONTAGE

- Etudier les schémas d'assemblage.
- Chaque pièce plastique porte un numéro d'identification.
- Contrôler que chaque pièce soit bien conforme avant de la coller à sa place.
- N'utilisez pas trop de colle pour réunir les pièces.
- Utilisez uniquement une colle spéciale pour polystyrène.
- Le modèle peut être peint conformément aux photos sur la boîte.

- Laissez sécher la peinture complètement, avant de manipuler les pièces.
- Grattez la peinture sur les surfaces devant être collées.
- Pour assurer la meilleure adhésion possible de la peinture et des décalcomanies, laver les pièces de plastique avec une légère solution savonneuse. Rincer et laisser sécher à l'air.

LEA ESTO ANTES DE EMPEZAR

- Estudie los dibujos de ensamble.
- Cada pieza de plástico se identifica por un número.
- Verifique que cada pieza encaje bien antes de pegar en posición.
- No use demasiado pegamento para unir las piezas.
- Use únicamente pegamento para plástico de poliestirina.
- El modelo puede pintarse de acuerdo con las fotografías de la caja.
- Permita que se seque la pintura completamente antes de tocar las piezas.
- Raspe la pintura de las superficies que serán pegadas.
- Para una mejor fijación de la pintura y de las decalcomanías, lávese las piezas plásticas en una solución de detergente suave. Enjuáguese y déjense secar al aire.



REPEAT SEVERAL TIMES
à REPETER PLUSIEURS FOIS
REPITA VARIAS VECES



DO NOT CEMENT
NE PAS COLLER
NO USE PEGAMENTO



DECAL (DIP IN WATER)
DECALCOMANIE (A PLONGER DANS L'EAU)
DECALCOMANIA (MOJE CON AGUA)

A	METALLIC	METALLIC	METALICO
B	ALUMINUM	ALUMINIUM	ALUMINIO
C	LIGHT GRAY	GRIS CLAIR	GRIS CLARO
D	DARK GRAY	GRIS FONCE	GRIS OSCURO
E	YELLOW	JAUNE	AMARILLO
F	TAN	BRUN CLAIR	CANELA
G	OLIVE GREEN	VERT OLIVE	VERDE OLIVA
H	DARK GREEN	VERT FONCE	VERDE OSCURO
J	BROWN	BRUN	MARRON
K	CRIMSON	CRAMOISI	CARMESI
L	BLACK	NOIR	NEGRO
M	LIGHT BLUE	BLEU CLAIR	AZUL CLARO
N	GRAY	GRIS	GRIS

1

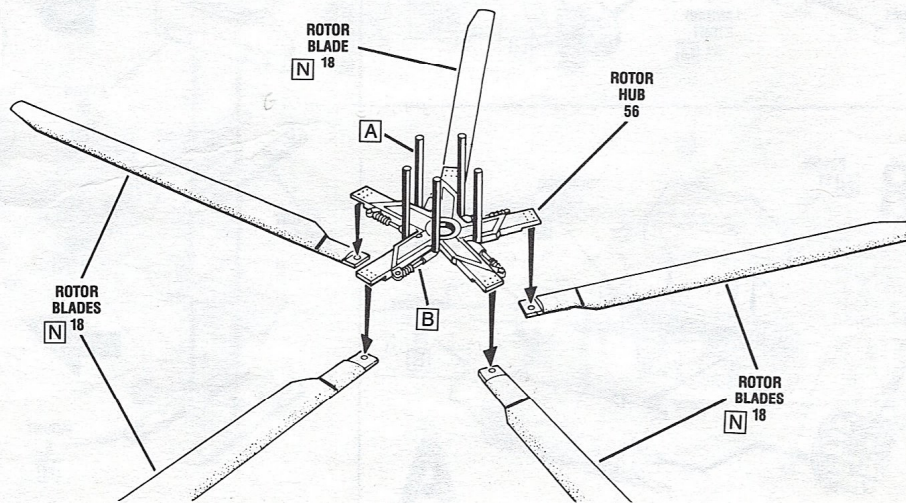

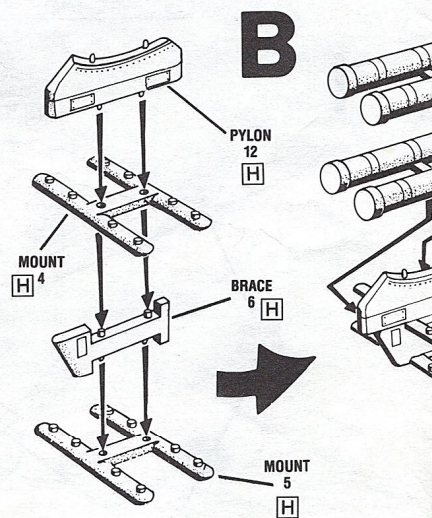
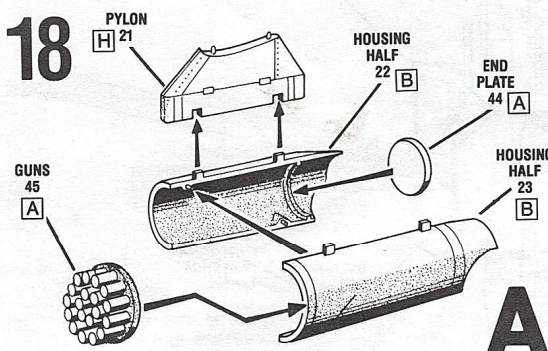
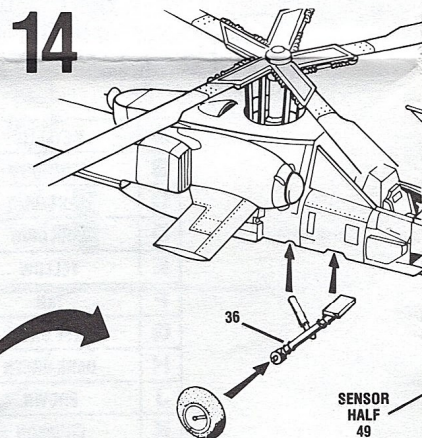
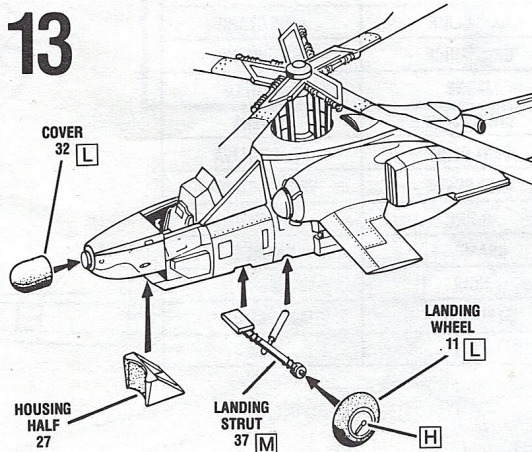
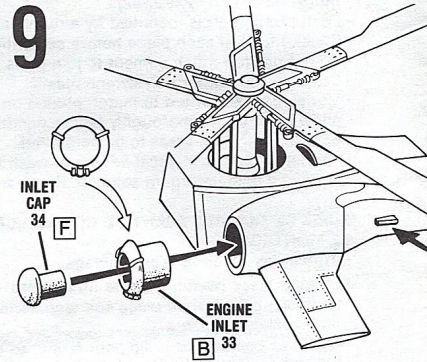
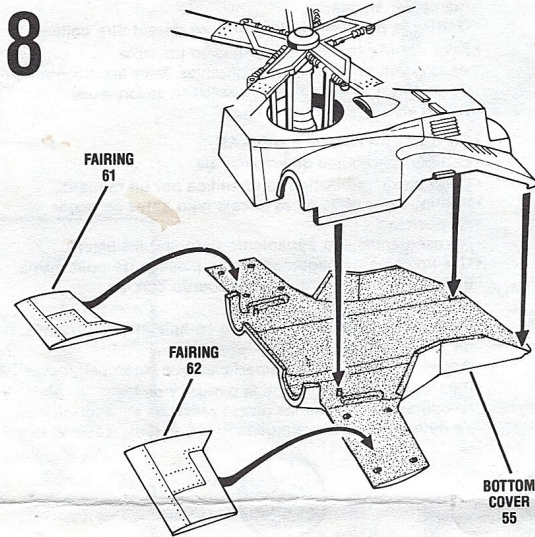
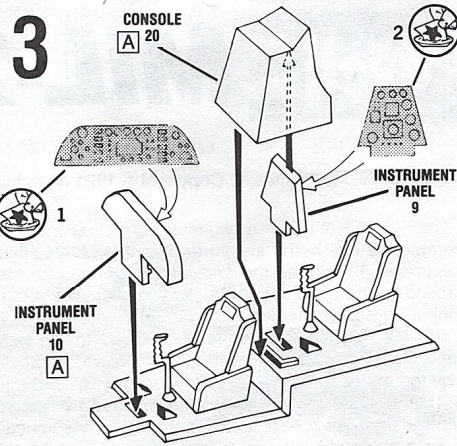
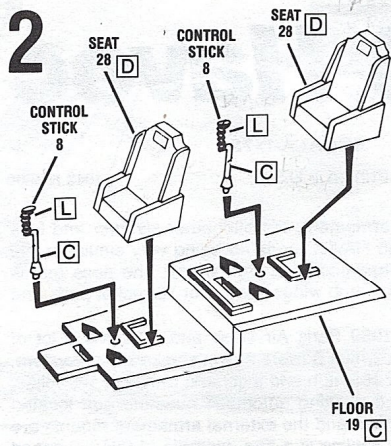

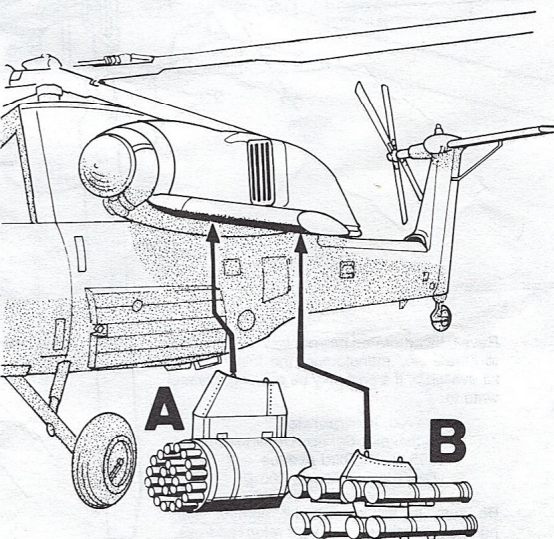
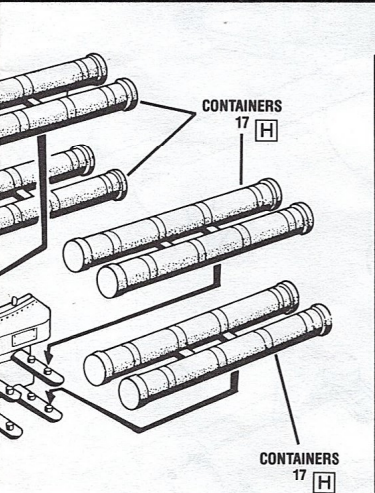
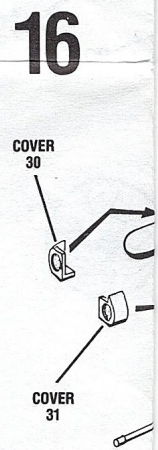
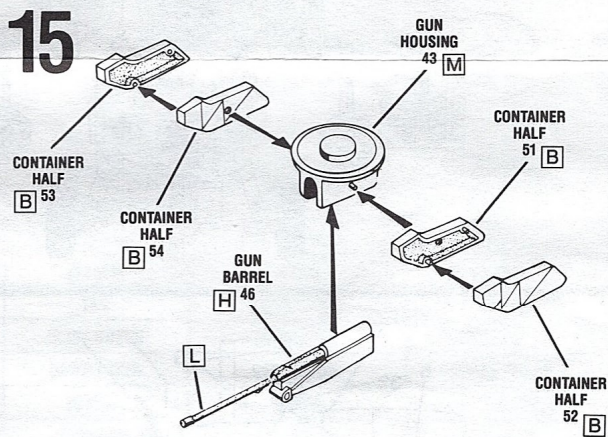
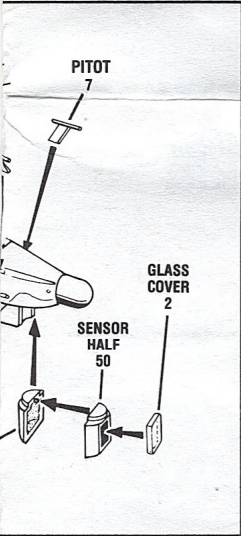
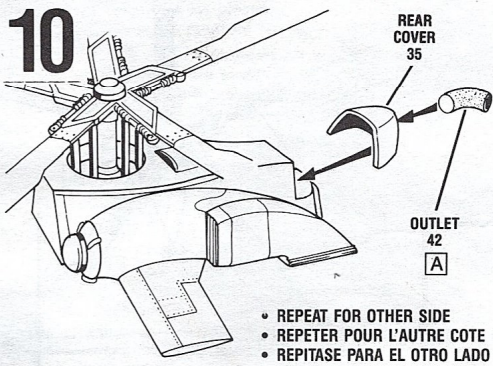
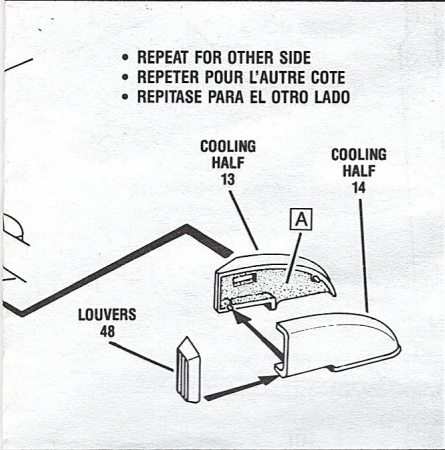
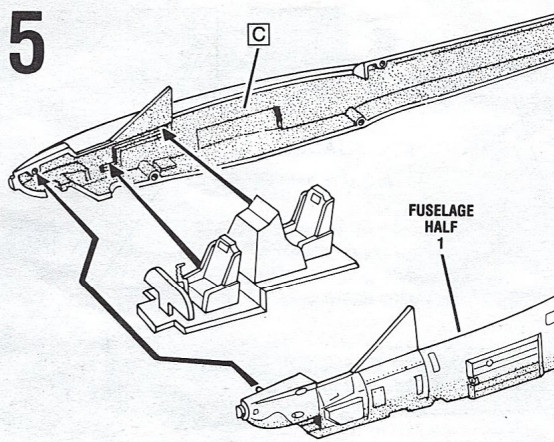
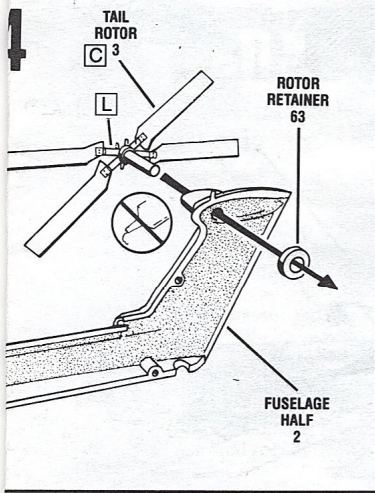

• REPEAT FOR OTHER SIDE
• REPETER POUR L'AUTRE COTE
• REPITASE PARA EL OTRO LADO

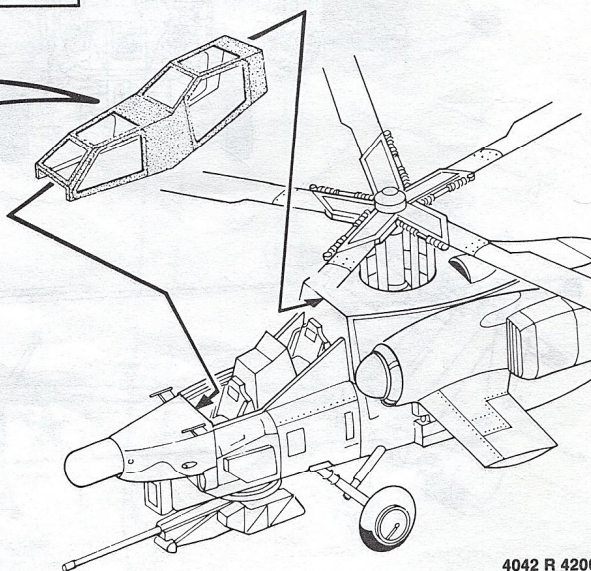
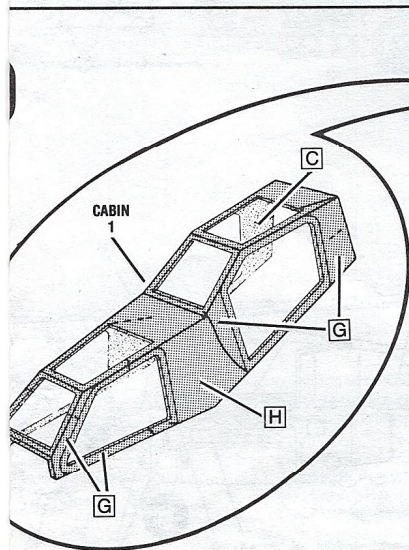
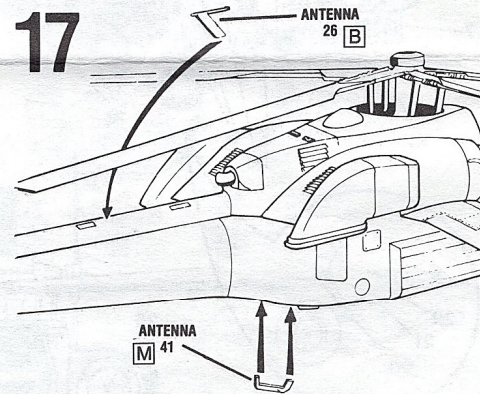
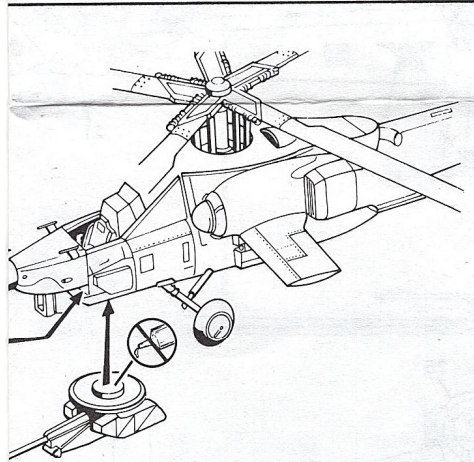
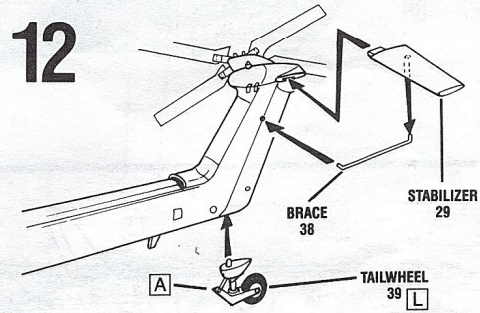
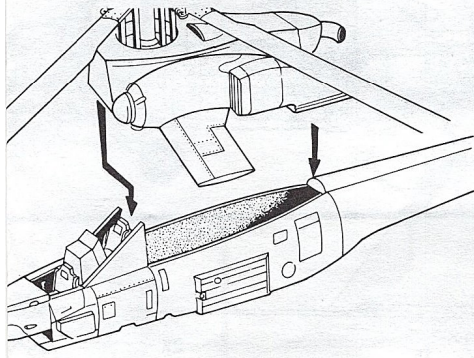
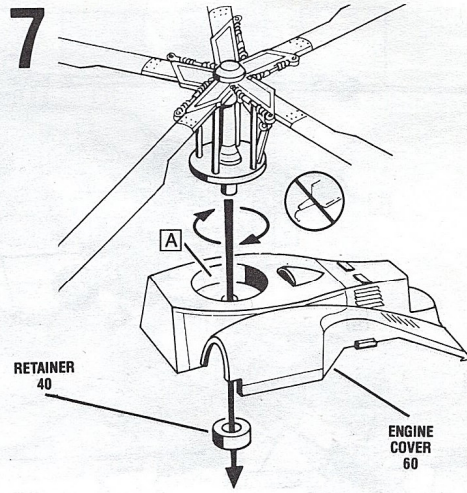
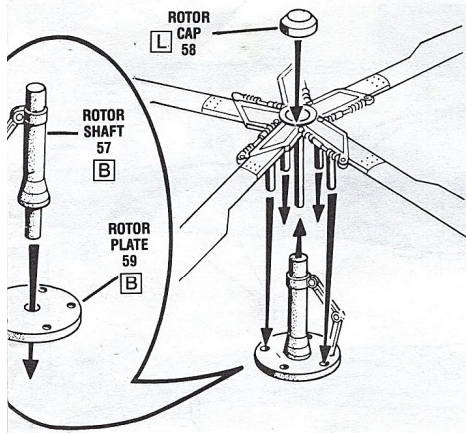

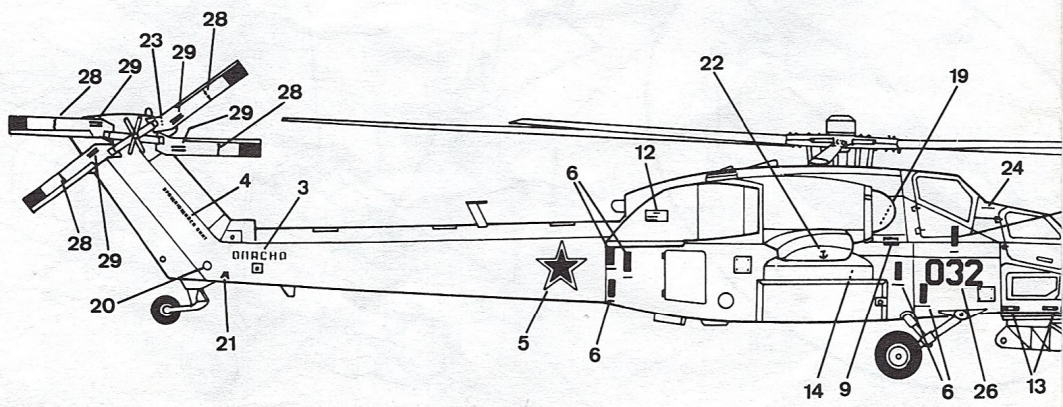
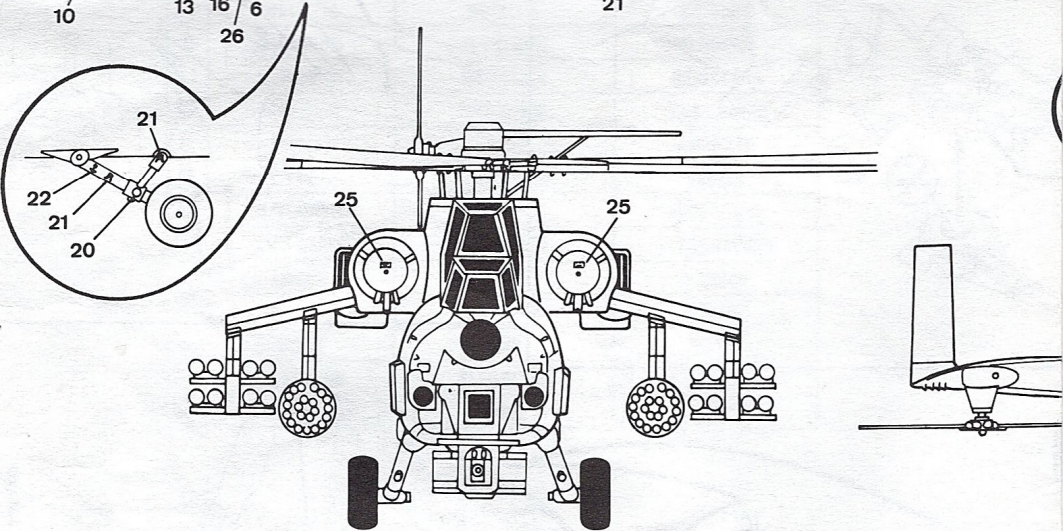
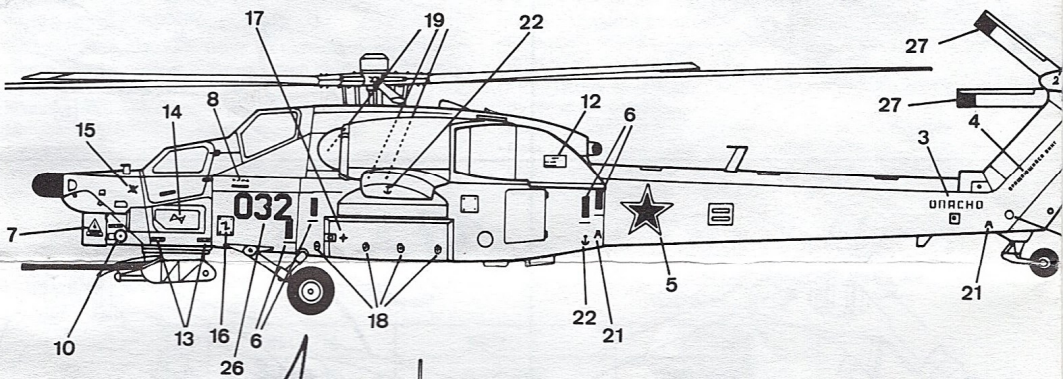
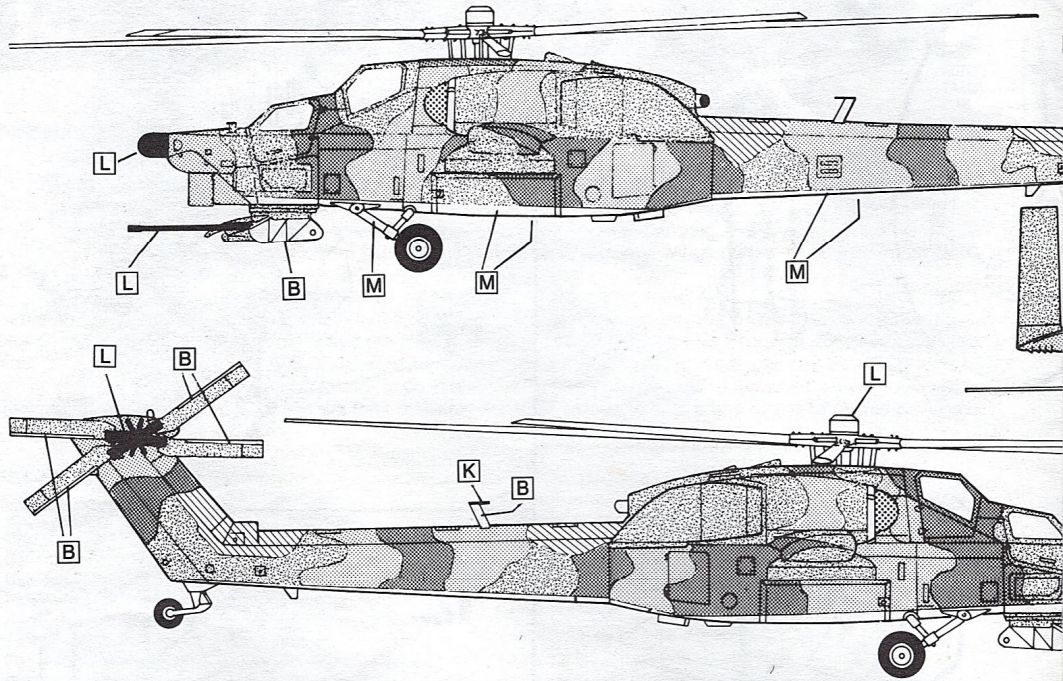

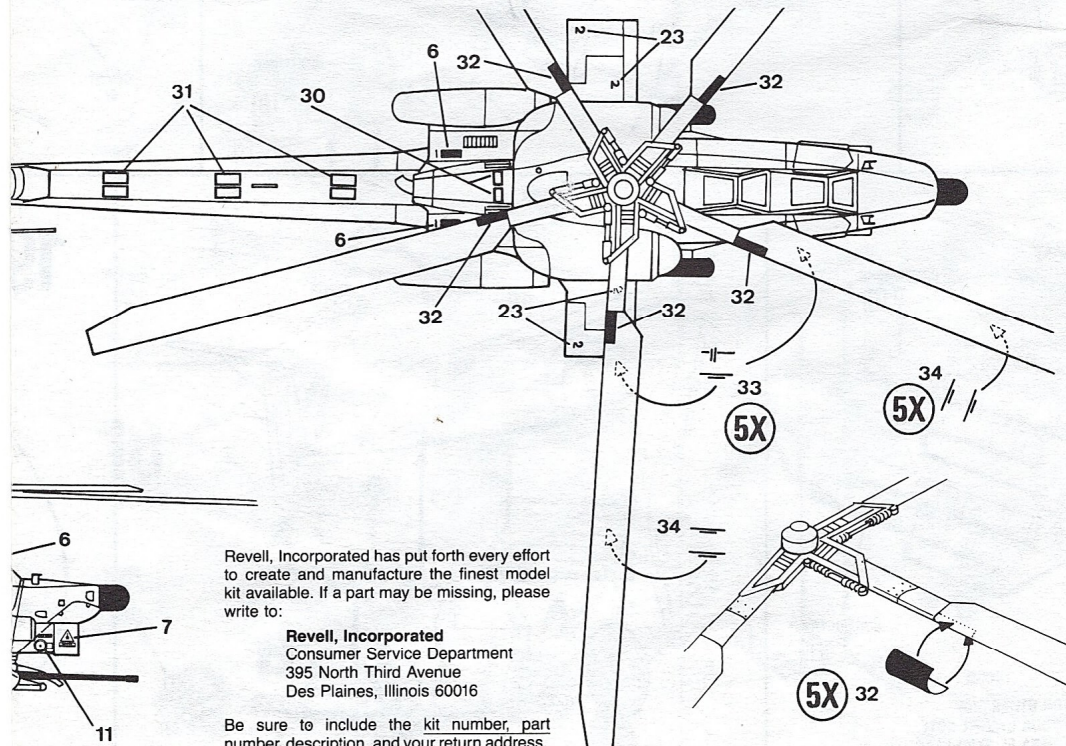
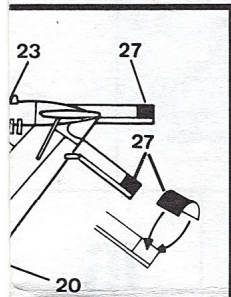
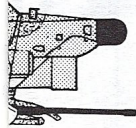
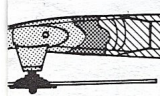
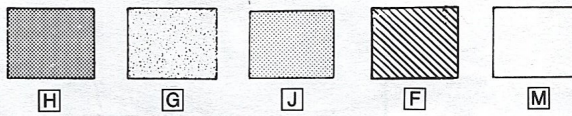
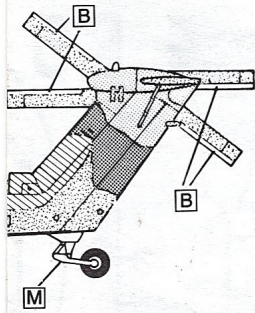

Revell, Incorporated has put forth every effort to create and manufacture the finest model kit available. If a part may be missing, please write to:

Revell, Incorporated
 Consumer Service Department
 395 North Third Avenue
 Des Plaines, Illinois 60016

Be sure to include the kit number, part number, description, and your return address.