

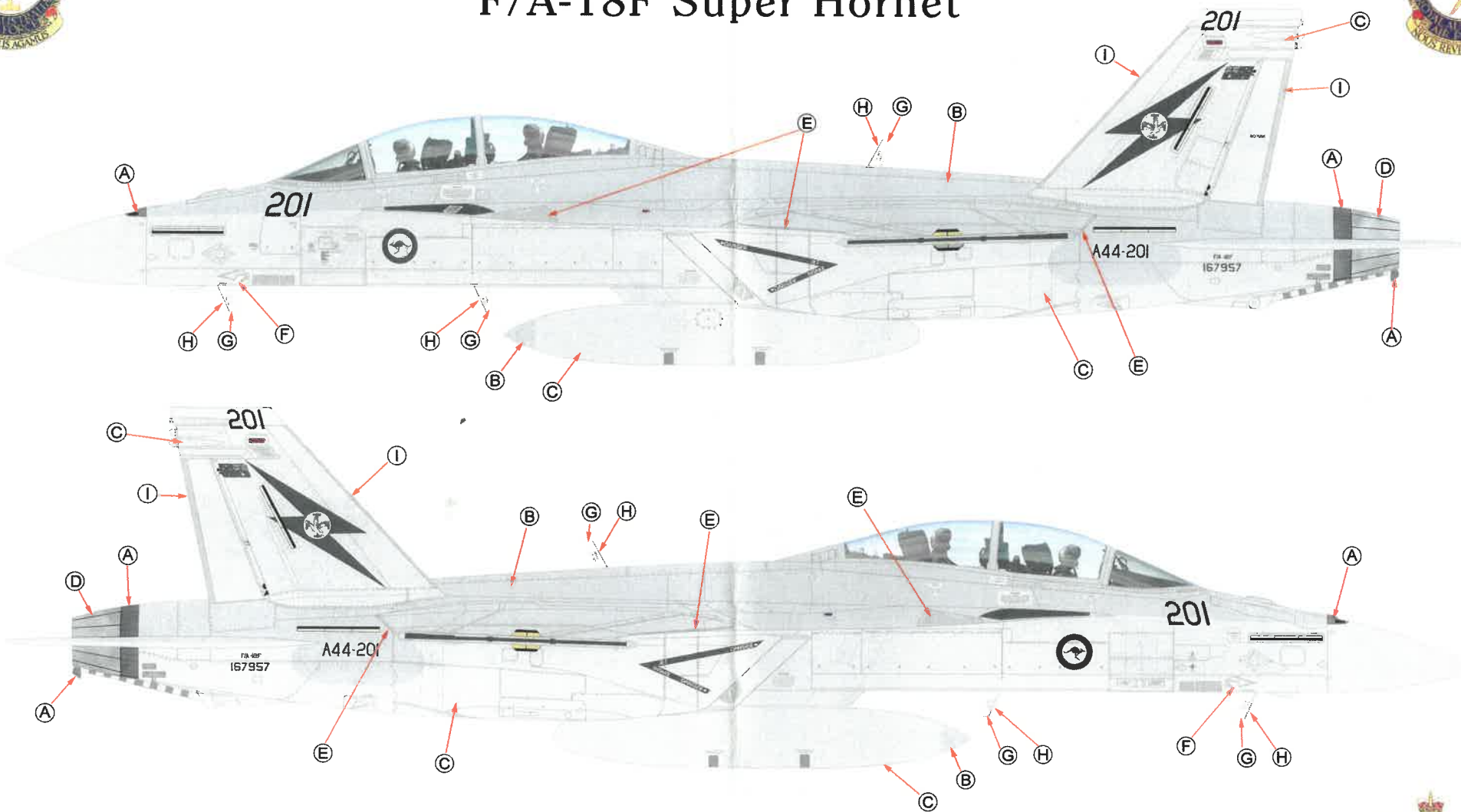

# Royal Australian Air Force 1 Squadron F/A-18F Super Hornet



Drawings by Steven Evans ©Copyright 2015

Reference:  
RAAF Website.  
[www.adf.gov.au](http://www.adf.gov.au)  
+Personal Pics

(A) Steel

(B) (Upper Surface)  
Dark Ghost Grey  
FS-36320

(C) (Lower Surface)  
Light Ghost Grey  
FS-36375

(D) Burnt Iron

(E) (Leading/trailing edges wing only)  
Dark Ghost Grey FS-36320  
+ 5% Medium Grey FS-35237

(F) Silver

(G) White

(I) (Leading and trailing edges of tail only)  
Light Ghost Grey FS-36375  
+ 5% Medium Grey FS-35237

(H) Matt Linen (Leading edges of antenna's)  
Hum 74



The RAAF Roundel, Squadron Markings and Badges have been reproduced under license and with permission and approval of the Royal Australian Air Force

PRINTED AND DESIGNED BY:

**ROMYR GRAPHICS AUSTRALIA**  
AUSTRALIAN MADE AND OWNED



# Royal Australian Air Force 6 Squadron F/A-18F+ Super Hornet 2010 - 2016

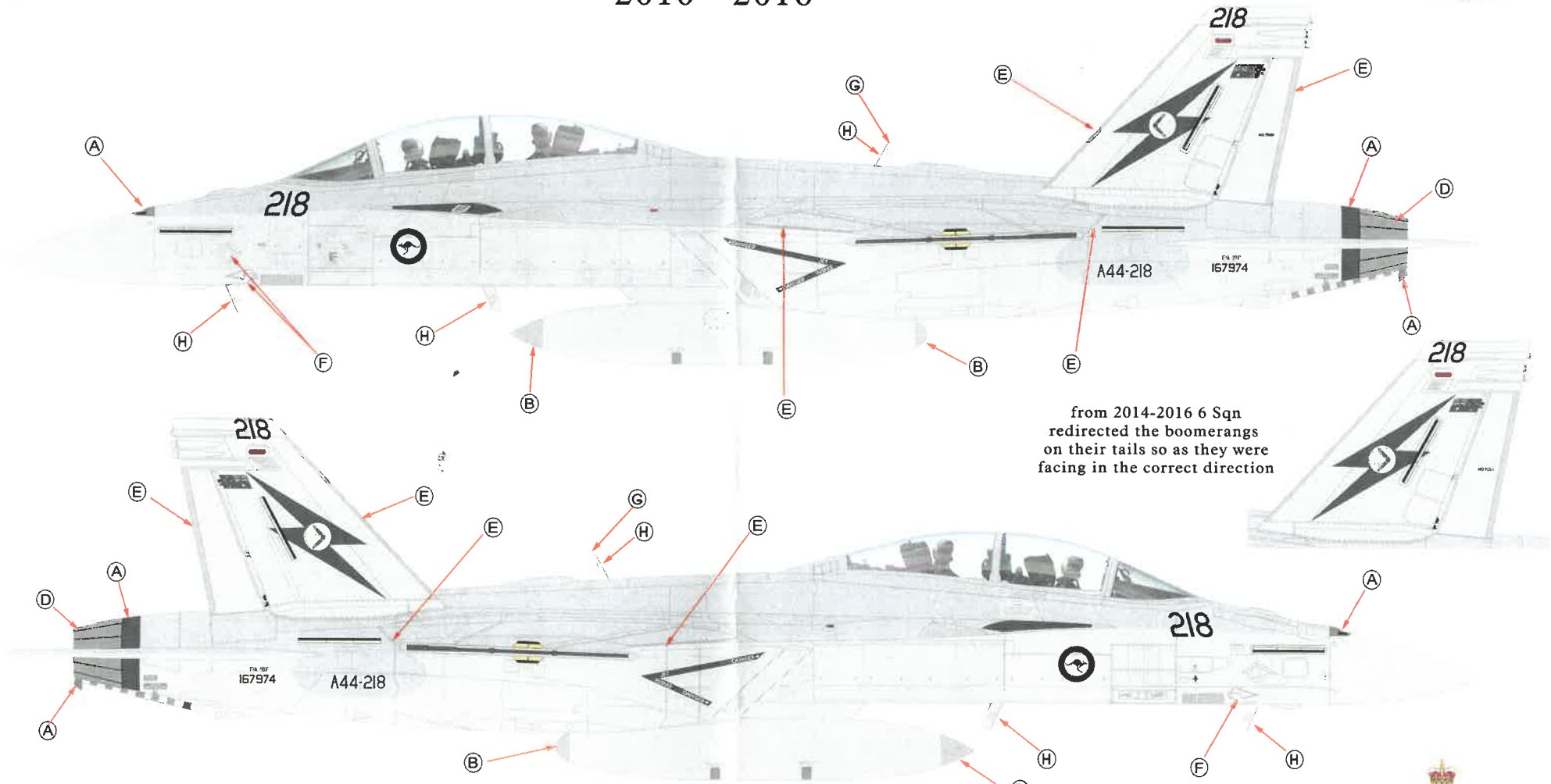

from 2014-2016 6 Sqn redirected the boomerangs on their tails so as they were facing in the correct direction

Drawings by Steven Evans © Copyright 2015

Reference:  
RAAF Website.  
www.adf.gov.au  
+Personal Pics

- |  |   |   |   |
|--|---|---|---|
| (A) Steel                                    | (C) (Lower Surface) Light Ghost Grey FS-36375 | (E) (Leading/trailing edges wing only) Dark Ghost Grey FS-36320 + 5% Medium Grey FS-35237 | (I) (Leading and trailing edges of tail only) Light Ghost Grey FS-36375 + 5% Medium Grey FS-35237 |
| (B) (Upper Surface) Dark Ghost Grey FS-36320 | (D) Burnt Iron                                | (F) Silver  | (H) Matt Linen (Leading edges of antenna's Hum 74)  |
|  |   | (G) White   |   |



The RAAF Roundel, Squadron Markings and Badges have been reproduced under license and with permission and approval of the Royal Australian Air Force

PRINTED AND DESIGNED BY:  
**RONNIE GRAPHICS AUSTRALIA**  
AUSTRALIAN MADE AND OWNED



# Royal Australian Air Force 1 Squadron F/A-18F+ Super Hornet 2016 -

In December 2016 all 6 Sqn F+ Super Hornets were transferred over to 1 Squadron due to 6 Squadron now being replenished with EA-18G's

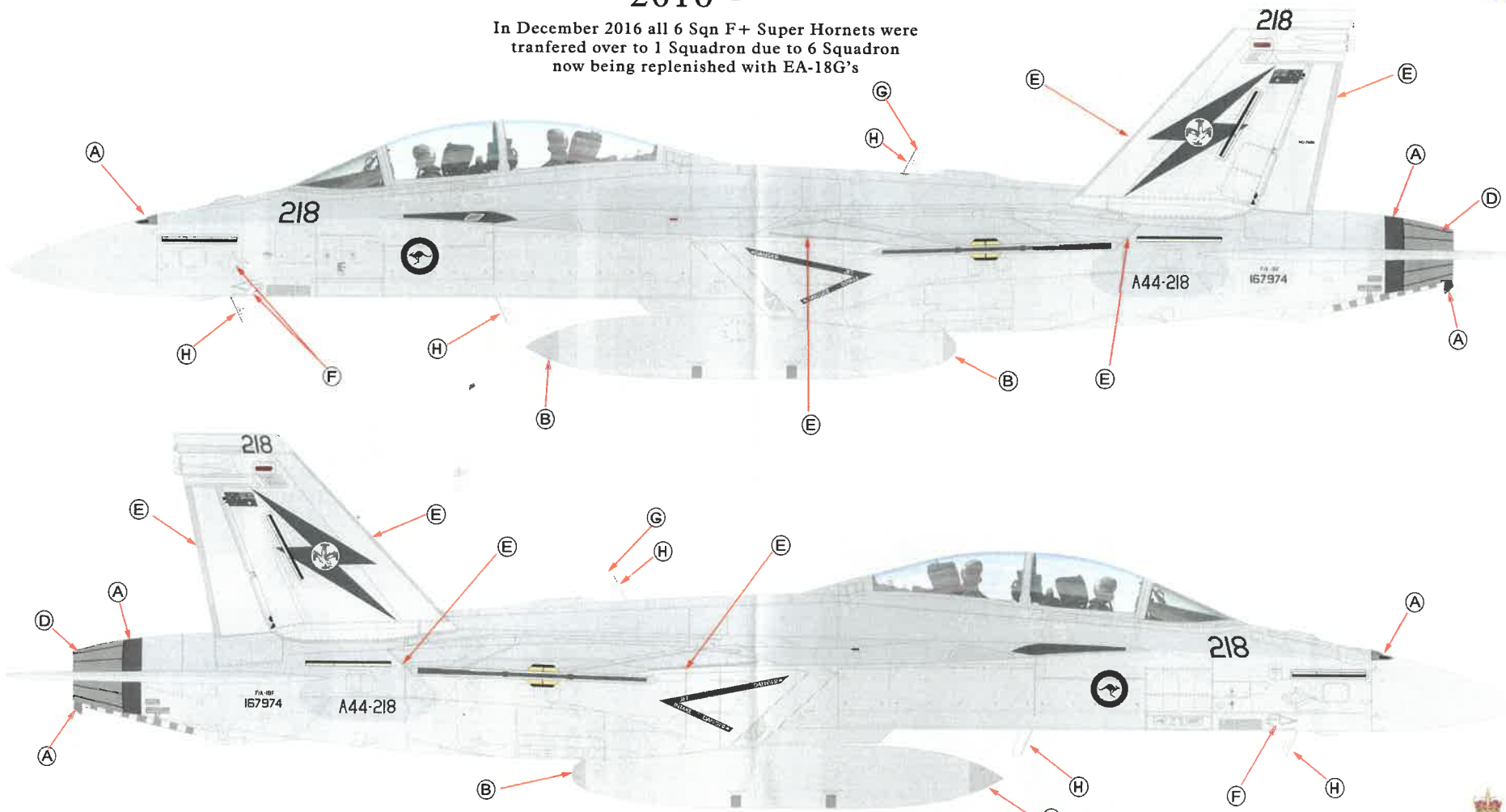

Drawings by Steven Evans © Copyright 2015

Reference:  
RAAF Website.  
www.adf.gov.au  
+Personal Pics

(A)

Steel

(C)

(Lower Surface)  
Light Ghost Grey  
FS-36375

(E)

(Leading/trailing edges wing only)  
Dark Ghost Grey FS-36320  
+ 5% Medium Grey FS-35237

(I)

(Leading and trailing edges of tail only)  
Light Ghost Grey FS-36375  
+ 5% Medium Grey FS-35237

(B)

(Upper Surface)  
Dark Ghost Grey  
FS-36320

(D)

Burnt Iron

(F)

Silver

(G)

White

(H)

Matt Linen (Leading edges of antenna's)  
Hum 74



The RAAF Roundel, Squadron Markings and Badges have been reproduced under license and with permission and approval of the Royal Australian Air Force

PRINTED AND DESIGNED BY:  
RONNIE GRAPHICS AUSTRALIA  
AUSTRALIAN MADE AND OWNED

# Super Hornet Close up

REFERENCE:  
ADF PHOTO LIBRARY (Public relations)  
www.airliners.net

Port side

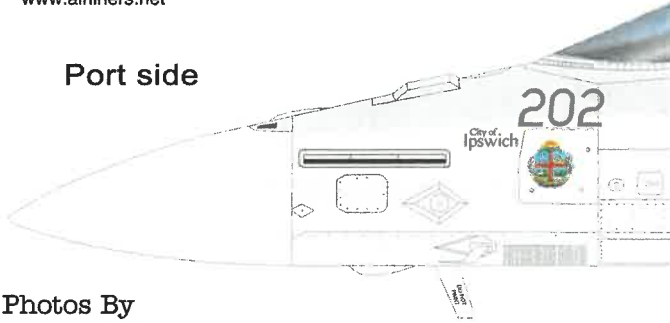

Shortly after arriving on the 26th March 2010 at RAAF Amberley, the new home for the RAAF F/A-18F Super Hornets, Aircraft A44-202 Bu No 167958 received its first nose art, "City of Ipswich", placed on the Port side only.

Photos By  
the RAAF

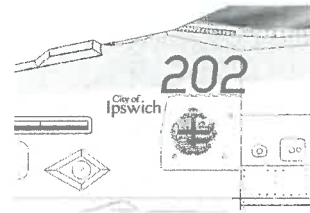

The "City of Ipswich" logo was later changed to low viz greys.

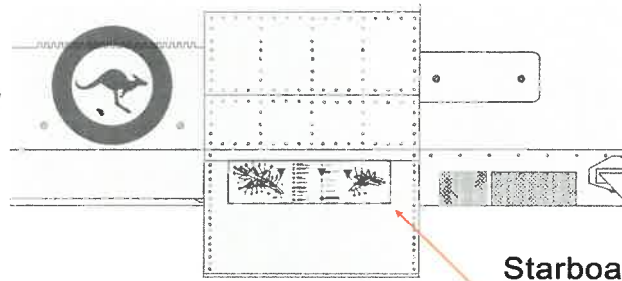

Starboard side

New style of data placard, position on the Starboard side forward undercarriage door



Aircraft numbers.

- A44-201 = 167957
- A44-202 = 167958
- A44-203 = 167959
- A44-204 = 167960
- A44-205 = 167961
- A44-206 = 167962

We assume that from here on they will be sequential down to  
A44-224 = 167980

1 Squadron F/A-18F

A44-201 - A44-212

2010 - 2016

6 Squadron F/A-18F+

A44-213 - A44-224

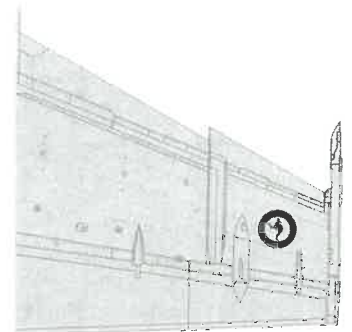

Note: There is a roundel on the bottom of each wing as shown





# Royal Australian Air Force 1 Squadron F/A-18F Super Hornet Operation OKRA 2015

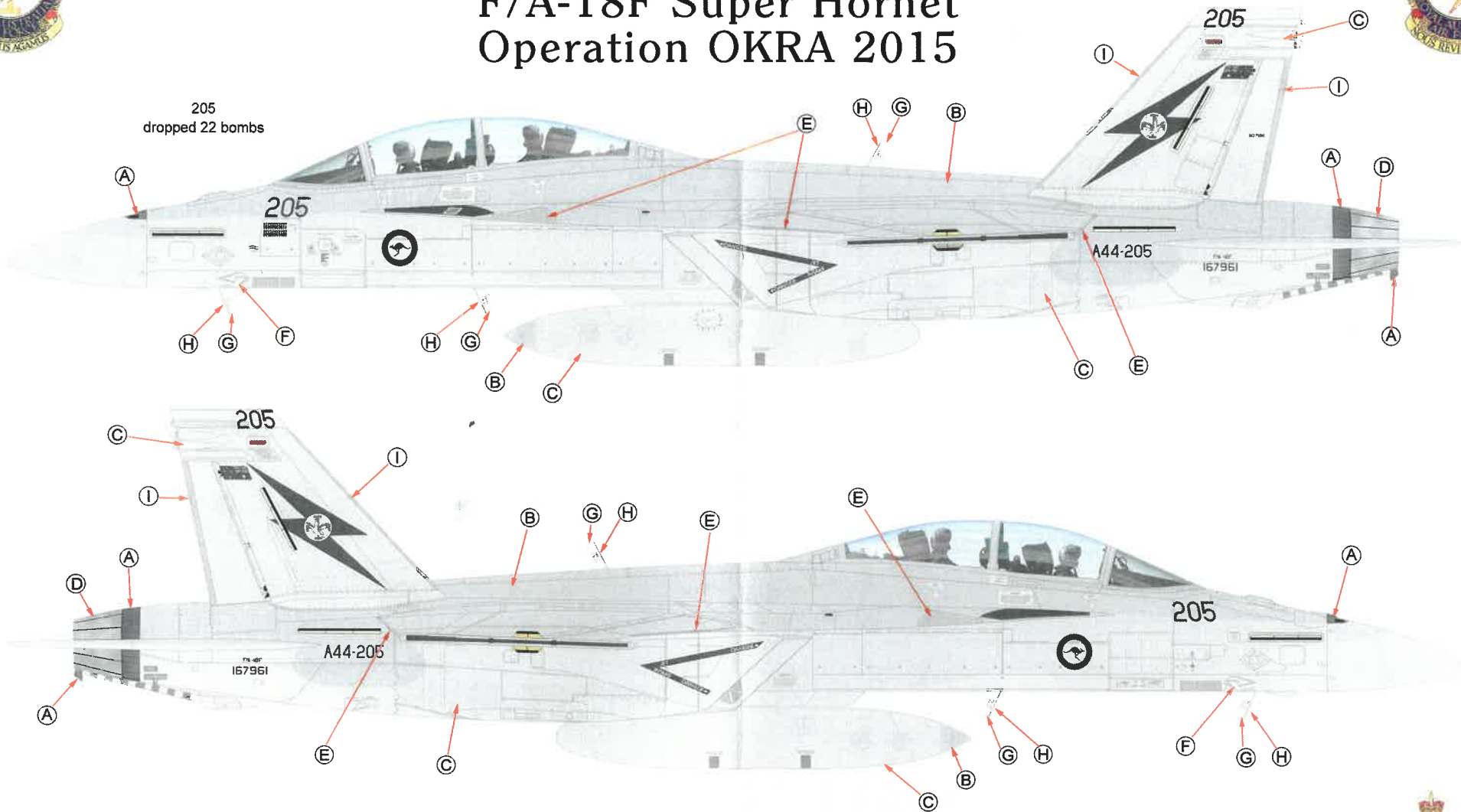

Drawings by Steven Evans © Copyright 2015

Reference:  
RAAF Website.  
[www.adf.gov.au](http://www.adf.gov.au)  
+Personal Pics

(A) Steel

(B) (Upper Surface)  
Dark Ghost Grey  
FS-36320

(C) (Lower Surface)  
Light Ghost Grey  
FS-36375

(D) Burnt Iron

(E) (Leading/trailing edges wing only)  
Dark Ghost Grey FS-36320  
+ 5% Medium Grey FS-35237

(F) Silver

(G) White

(I) (Leading and trailing edges of tail only)  
Light Ghost Grey FS-36375  
+ 5% Medium Grey FS-35237

(H) Matt Linen (Leading edges of antenna's)  
Hum 74



The RAAF Roundel, Squadron Markings and Badges  
have been reproduced under license and with permission  
and approval of the Royal Australian Air Force

PRINTED AND DESIGNED BY:  
**ROWTH GRAPHICS AUSTRALIA**  
AUSTRALIAN MADE AND OWNED



# Royal Australian Air Force 6 Squadron F/A-18F+ Super Hornet Operation OKRA 2015

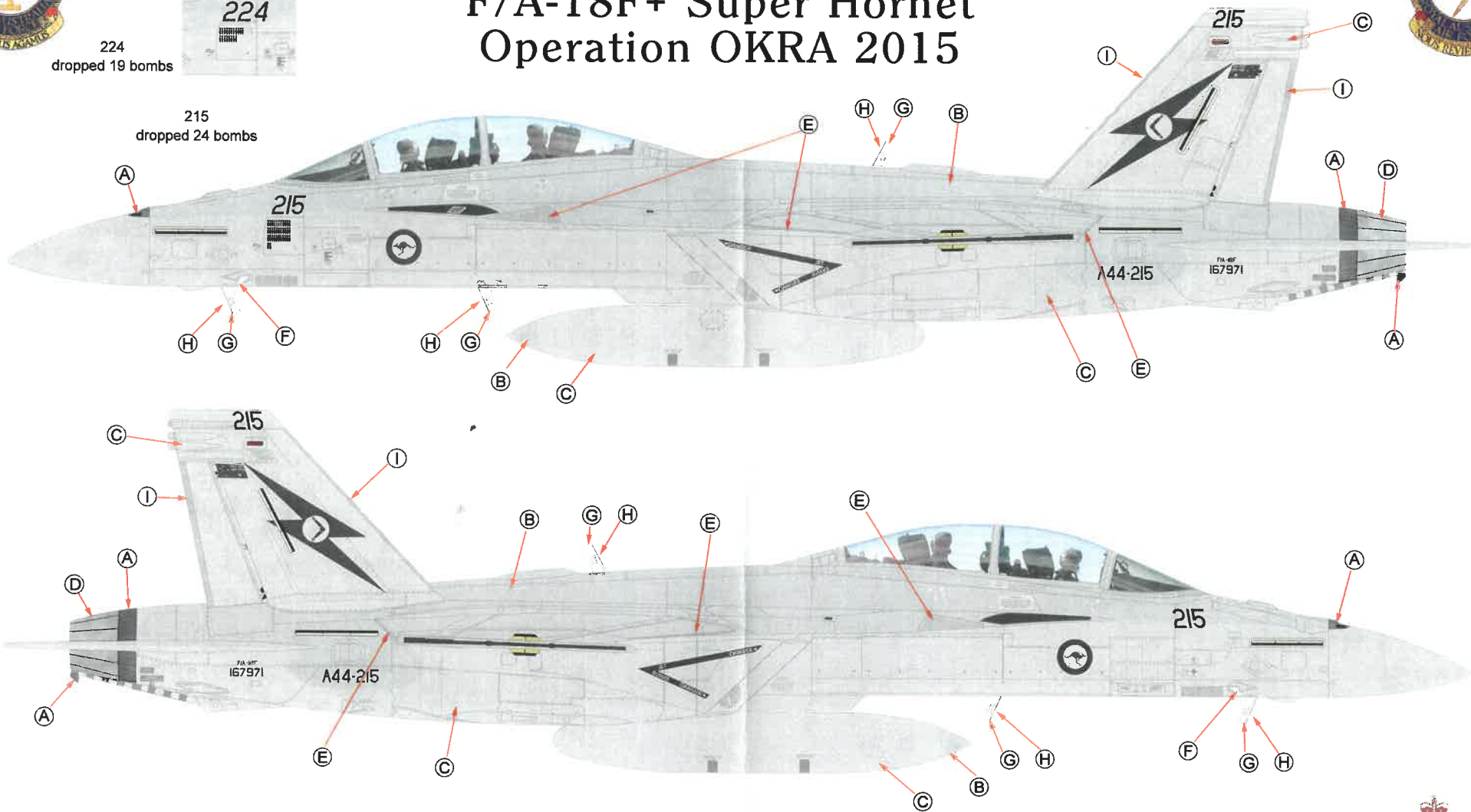

Drawings by Steven Evans ©Copyright 2015

Reference:  
RAAF Website.  
www.adf.gov.au  
+Personal Pics

(A) Steel

(B) (Upper Surface  
Dark Ghost Grey  
FS-36320

(C) (Lower Surface)  
Light Ghost Grey  
FS-36375

(D) Burnt Iron

(E) (Leading/trailing edges wing only)  
Dark Ghost Grey FS-36320  
+ 5% Medium Grey FS-35237

(F) Silver

(G) White

(I) (Leading and trailing edges of tail only)  
Light Ghost Grey FS-36375  
+ 5% Medium Grey FS-35237

(H) Matt Linen (Leading edges of antenna's)  
Hum 74



The RAAF Roundel, Squadron Markings and Badges  
have been reproduced under license and with permission  
and approval of the Royal Australian Air Force

PRINTED AND DESIGNED BY:

**ROMYTH GRAPHICS AUSTRALIA**  
AUSTRALIAN MADE AND OWNED

# 1 Squadron Supers in Op Okra 2017

F/A-18F  
167957

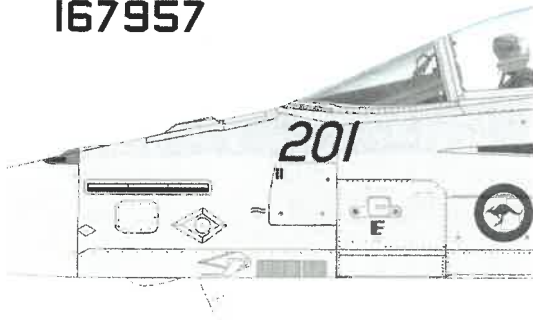

F/A-18F  
167958

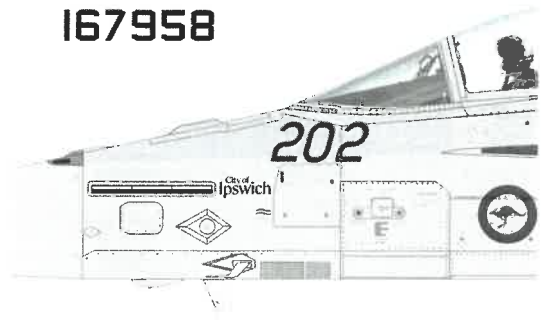

F/A-18F  
167959

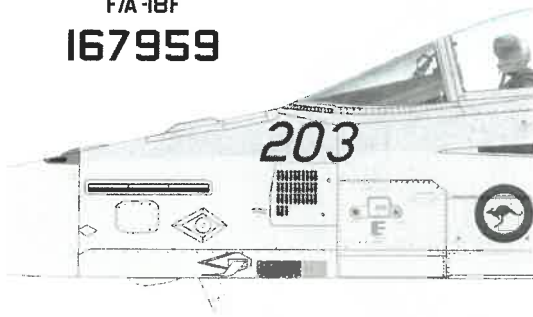

F/A-18F  
167960

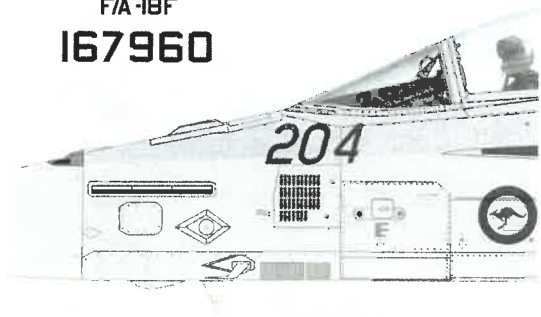

F/A-18F  
167967

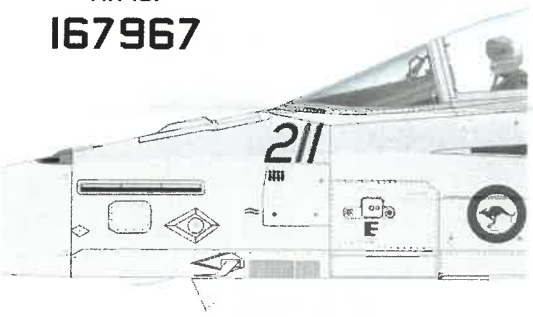

F/A-18F  
167969

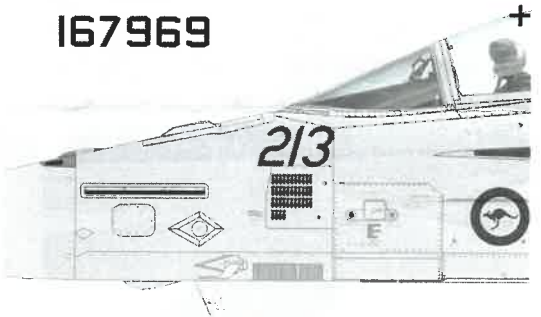

F/A-18F  
167978

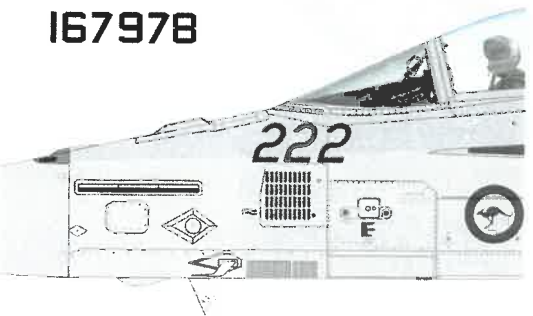

F/A-18F  
167979

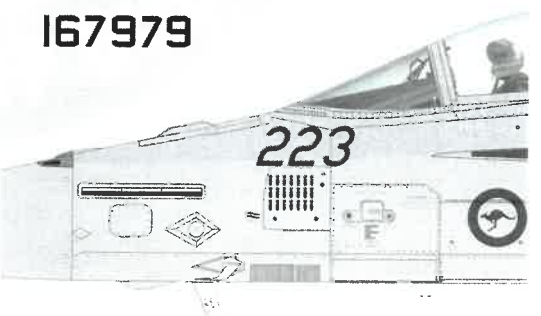

Reference:  
RAAF images website  
Google Images  
USAF Images Website  
Airliners.net  
Airpower.net

# Super Hornet Close up

F/A-18F 1 Sqn  
**167965** F/A-18F

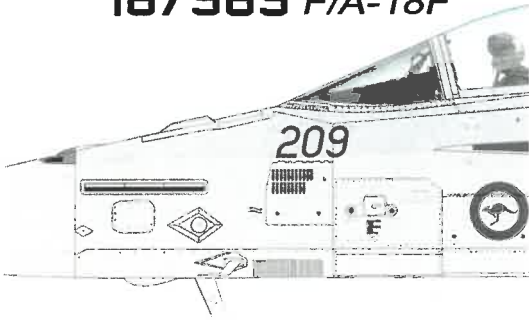

F/A-18F 1 Sqn  
**167968** F/A-18F

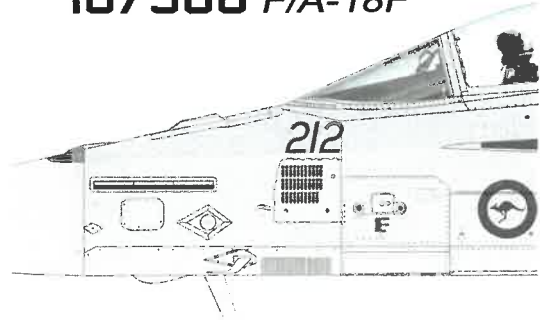

F/A-18F 1 Sqn  
**167976** F/A-18F+

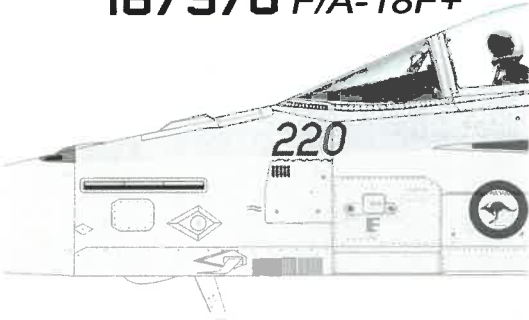

F/A-18F 6 Sqn  
**167980** F/A-18F+

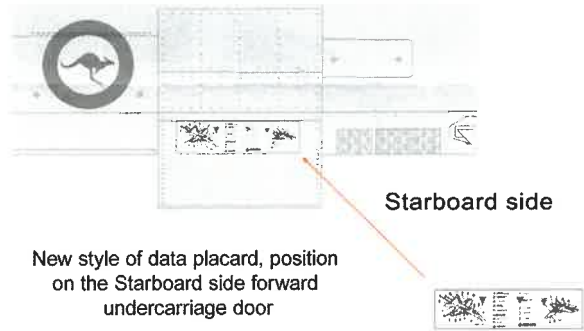
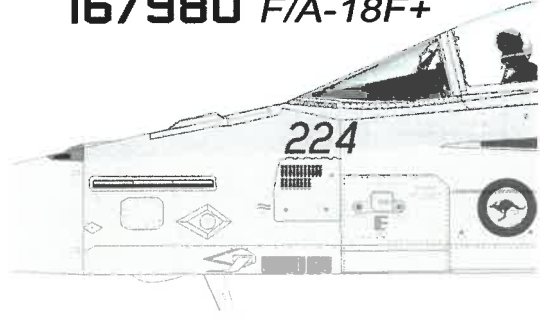

*Photo's by defence PR*

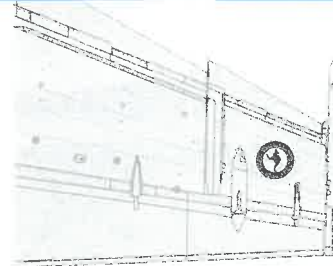

Note: There is a roundel on the bottom of each wing as shown



This set is designed for the RAAF Super Hornets only.

Note: Lighter text (Data) goes on the upper surface (Darker surface) and the darker text (Data) goes on the lower (Lighter surface)

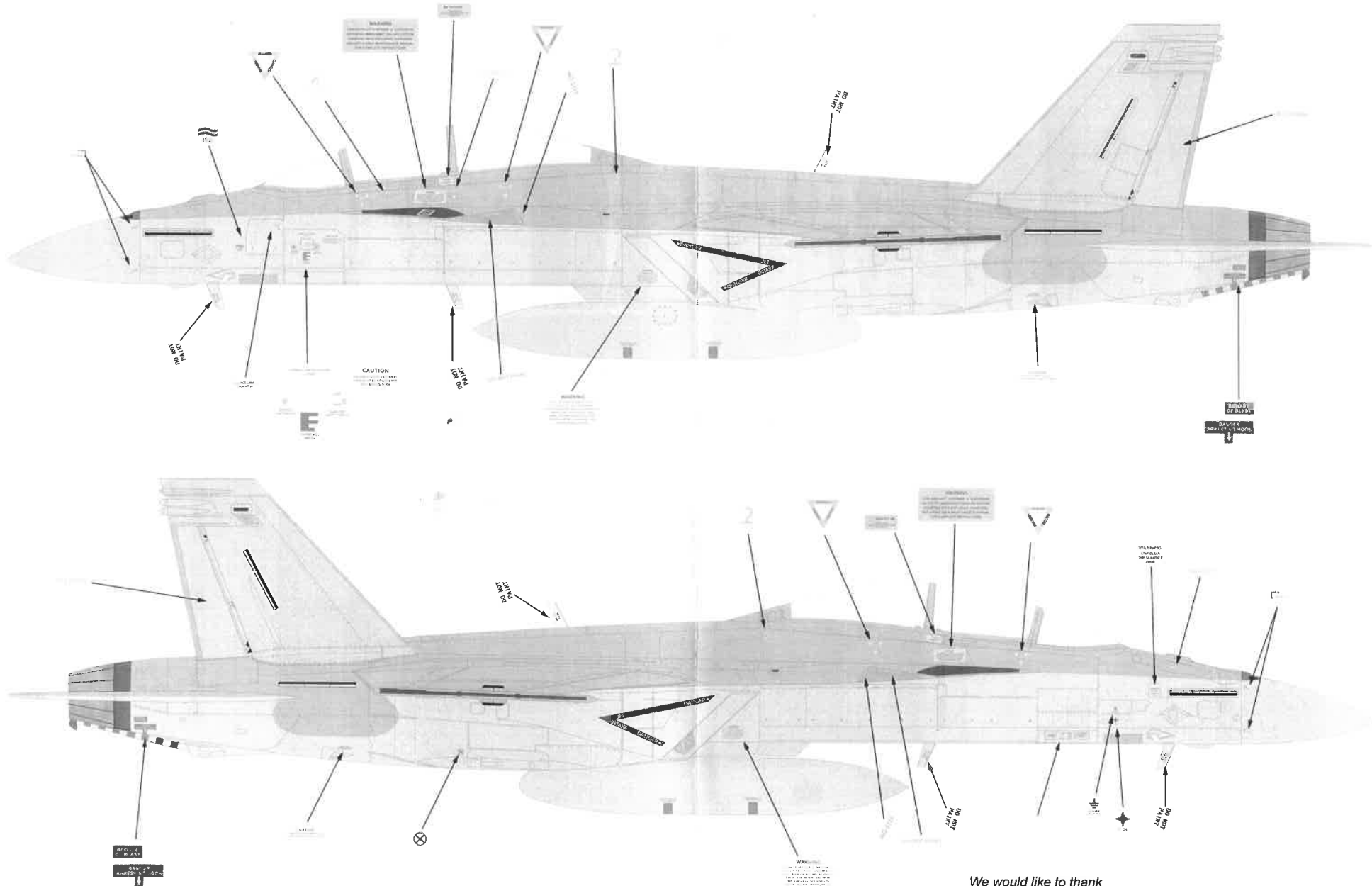

We would like to thank  
CVW-5 USN Atsugi, Japan  
and 1 & 6 Sqn RAAF Amberly  
For their help in the production of this data set.

PRINTED AND DESIGNED BY:  
ROBTH GRAPHICS AUSTRALIA  
AUSTRALIAN MADE AND OWNED

# RAAF SUPER HORNET EXTRA DETAIL



These white decals are for the inside Exhaust Feathers

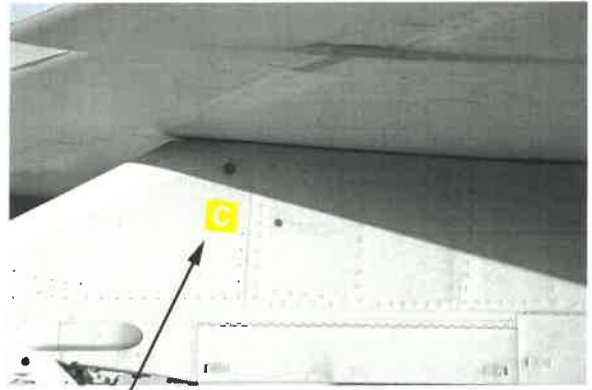

The C square goes on both sides of the middle wing pylons



This decal goes on the bottom of all external fuel tanks.

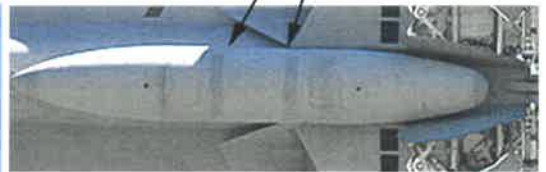

PRINTED AND DESIGNED BY:  
**ROTHM GRAFPHICS AUSTRALIA**  
 AUSTRALIAN MADE AND OWNED

We would like to thank  
 CVW-5 USN Atsugi, Japan  
 and 1 & 6 Sqn RAAF Amberly  
 For their help in the production of this data set.

This set is designed for the RAAF Super Hornets only.

Note: Lighter text (Data) goes on the upper surface (Darker surface) and the darker text (Data) goes on the lower (Lighter surface)

**RDS-156 RAAF F/A-18F Super Hornets 2017**

This set is designed for the RAAF Super Hornets only.

Note: Lighter text (Data) goes on the upper surface (Darker surface) and the darker text (Data) goes on the lower (Lighter surface)

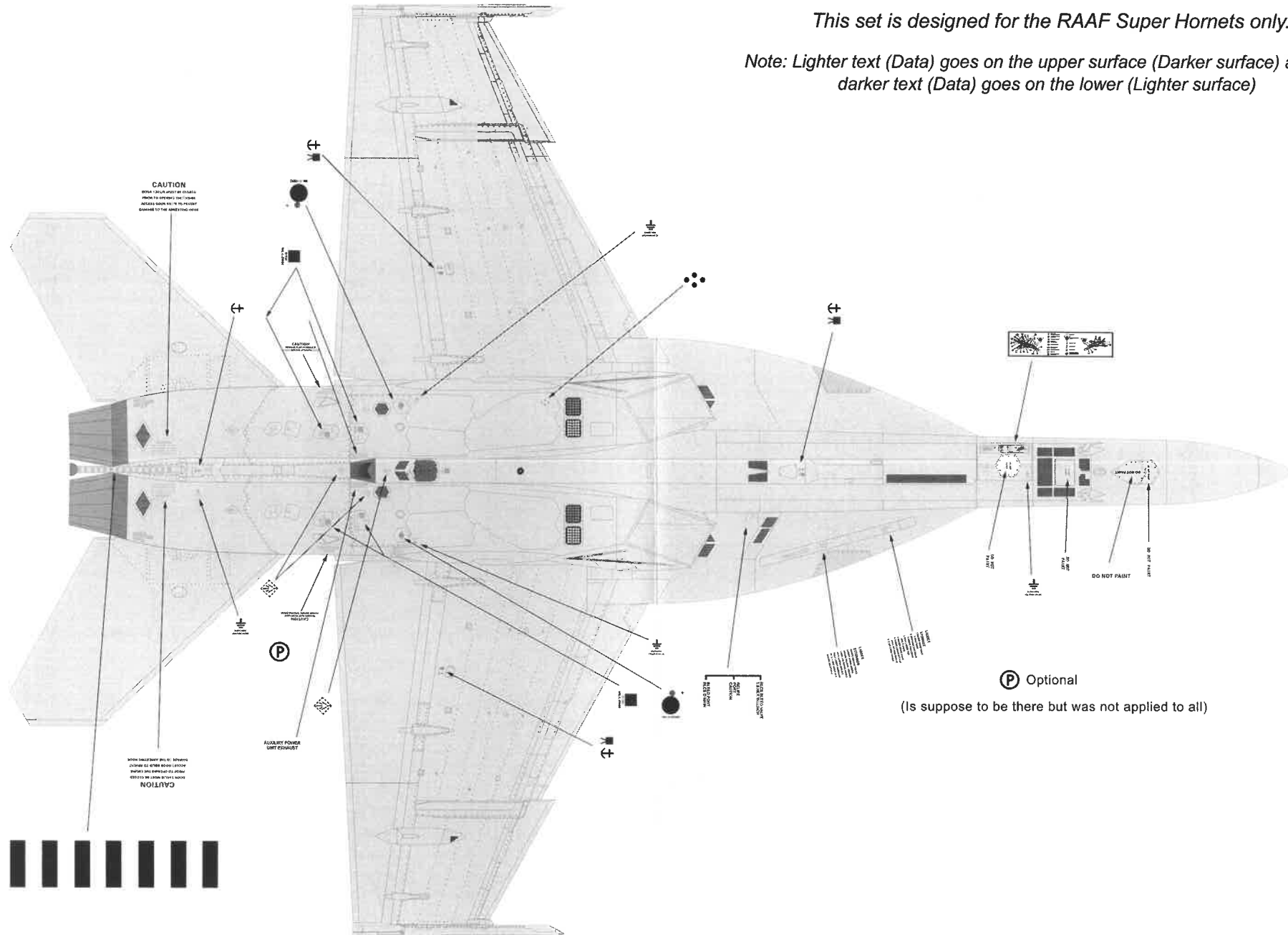

This set is designed for the RAAF Super Hornets only.

Note: Lighter text (Data) goes on the upper surface (Darker surface) and the darker text (Data) goes on the lower (Lighter surface)

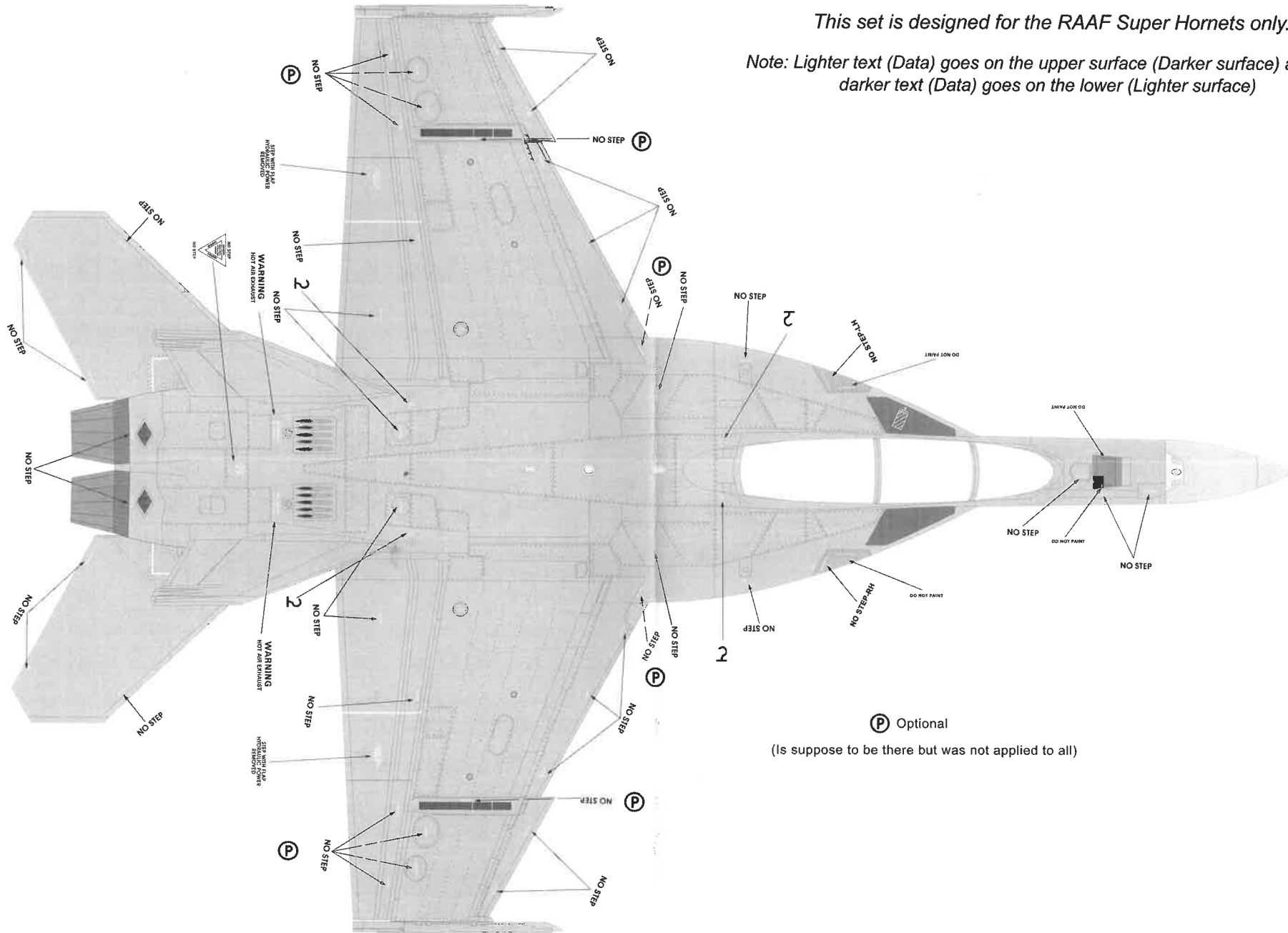

(P) Optional

(Is suppose to be there but was not applied to all)

later versions are black / silver

FORWARD

D2

D3

D4

# Forward undercarriage doors

D6

PRINTED AND DESIGNED BY:  
**ROYAL GRAPHICS AUSTRALIA**  
AUSTRALIAN MADE AND OWNED



D5

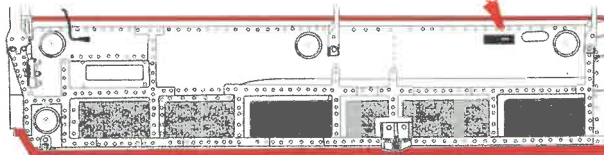

## Forward undercarriage

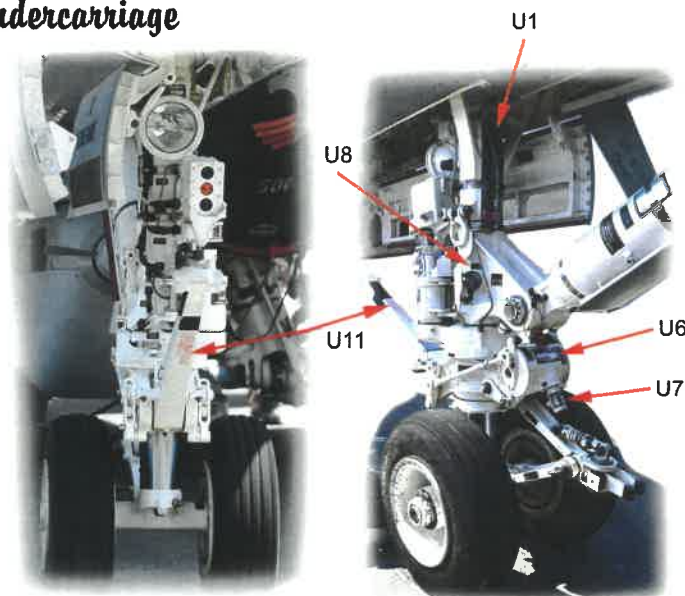
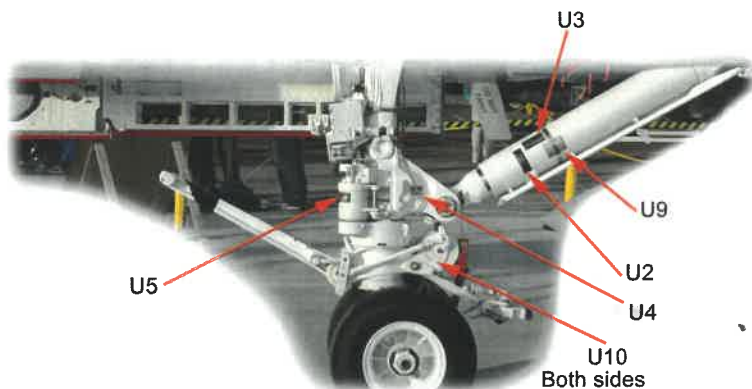

## Rear undercarriage doors

Starboard side

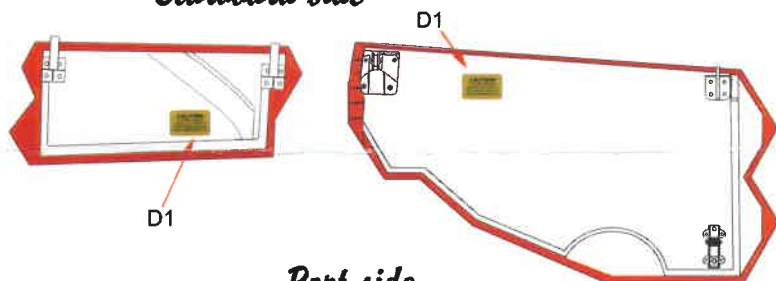

Port side

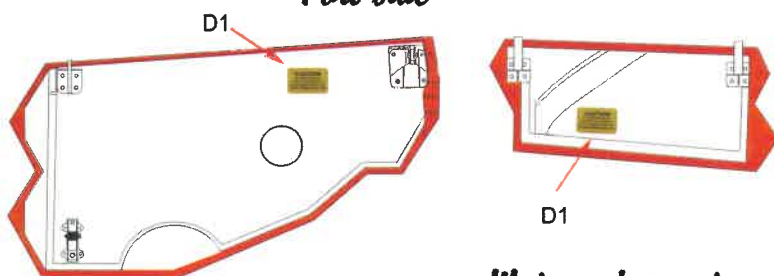

Special thanks to USN's CVW-5 and the RAAF 1 Sqn for allowing us close up access to there jets.



U16

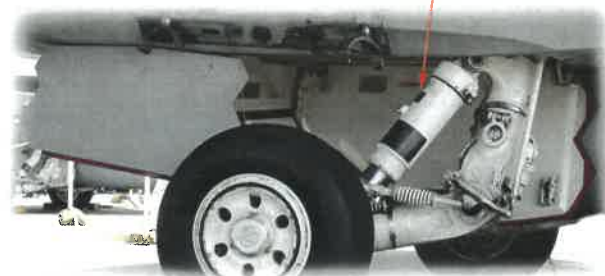

## Main undercarriage

U13

U14

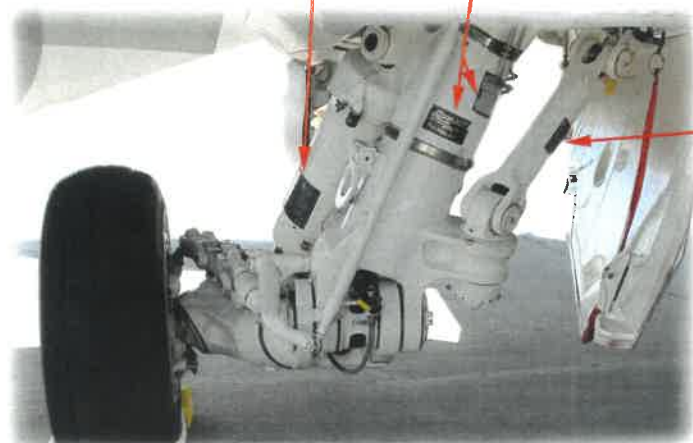

U12

U15

U16

U13

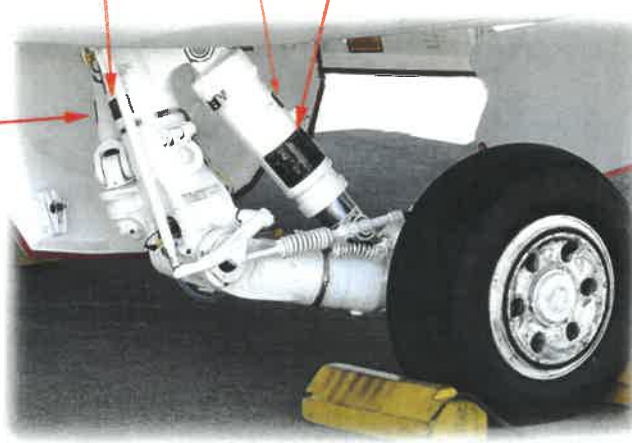

Starboard side rear undercarriage leg

Port side undercarriage leg

# Ejection Seat

SJU-17 (V) 1/A - 2/A

PRINTED AND DESIGNED BY:  
**ROYAL GRAPHICS AUSTRALIA**  
 AUSTRALIAN MADE AND OWNED

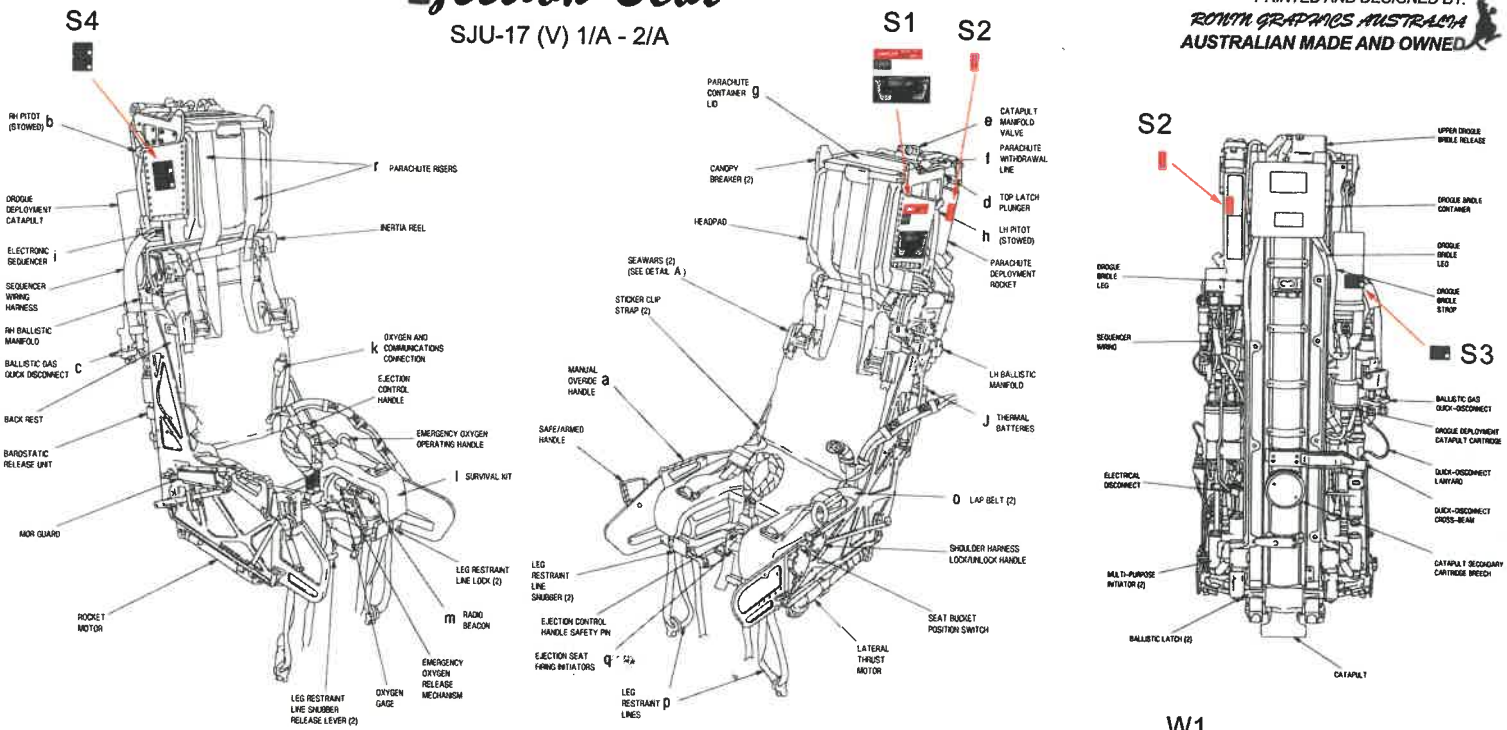

## Aileron Shroud Plate

Apply to both sides of aircraft

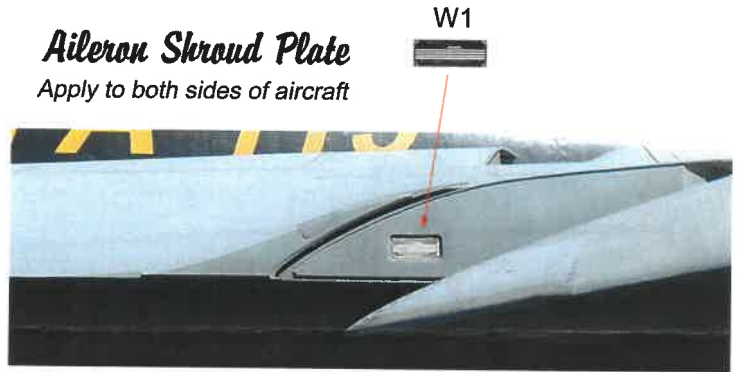

## ATFLIR POD

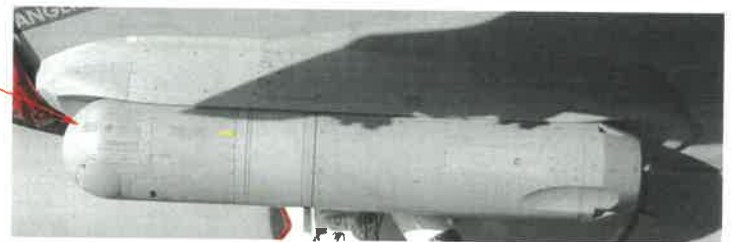

ID Plate behind rear seat



L2



L1 on opposite side



## External Fuel Tanks

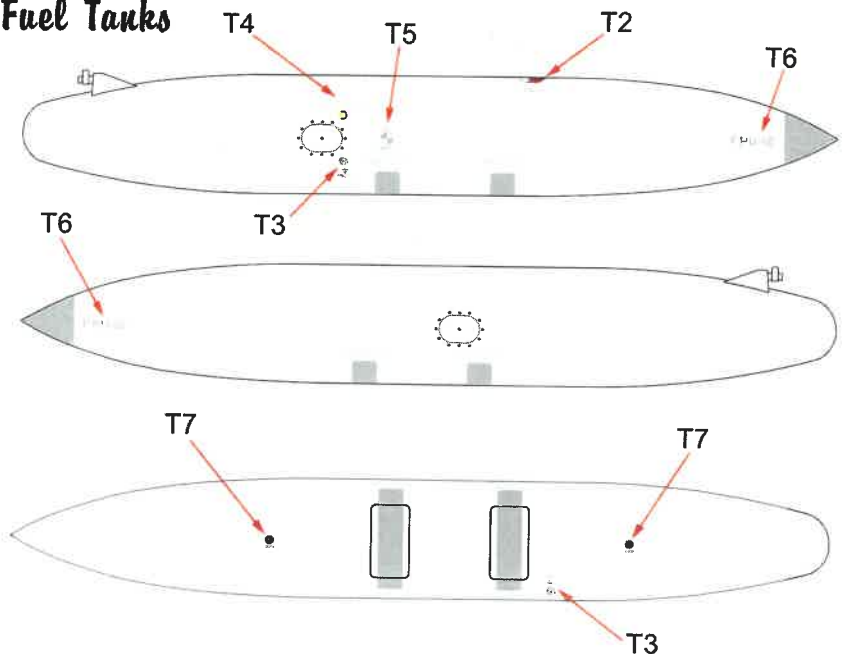

This decal goes on the bottom of all external fuel tanks.



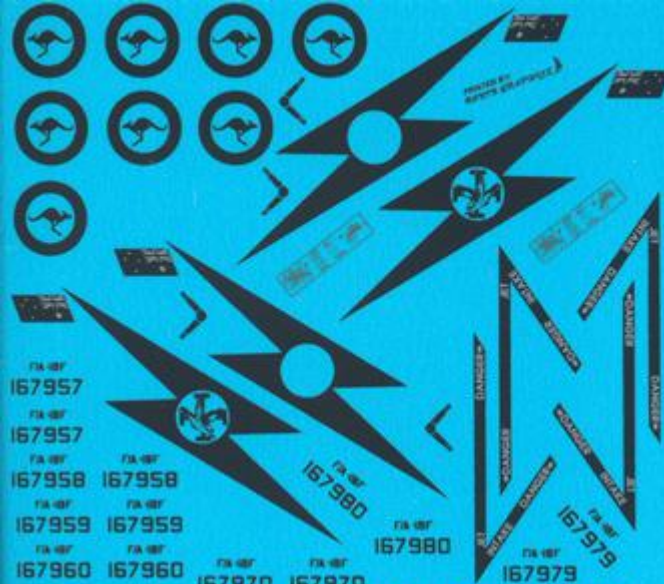

201	201	211	211	221	221	201	202
202	202	212	212	222	222	203	204
203	203	213	213	223	223		
204	204	214	214	224	224	205	209
205	205	215	215	202	202	211	212
206	206	216	216	203	203		
207	207	217	217	204	204	213	215
208	208	218	218	205	205		
209	209	219	219	206	206	220	222
210	210	220	220	207	207		
				208	208	223	224
				209	209		
				220	220	spares	
				221	221		
				222	222	sw	
				223	223	ipswich	
				224	224		
				219	219		

F/A-18F	F/A-18F			A44-201	A44-201	A44-216	A44-216	201	201	217	217	218	218
167957	167957			A44-202	A44-202	A44-217	A44-217	210	210				
F/A-18F	F/A-18F			167972	167972	A44-218	A44-218	211	211				
167959	167959			167973	167973	A44-219	A44-219	212	212				
F/A-18F	F/A-18F			167974	167974	A44-220	A44-220	213	213				
167960	167960			167975	167975	A44-221	A44-221	214	214				
F/A-18F	F/A-18F			167976	167976	A44-222	A44-222	215	215				
167961	167961			167977	167977	A44-223	A44-223	216	216				
F/A-18F	F/A-18F			167978	167978	A44-224	A44-224						
167962	167962			A44-211	A44-211	A44-212	A44-212						
F/A-18F	F/A-18F			A44-213	A44-213	A44-214	A44-214						
167963	167963			A44-214	A44-214	A44-215	A44-215						
F/A-18F	F/A-18F												
167964	167964												
F/A-18F	F/A-18F												
167965	167965												
F/A-18F	F/A-18F												
167966	167966												
F/A-18F	F/A-18F												
167967	167967												
F/A-18F	F/A-18F												
167968	167968												
F/A-18F	F/A-18F												
167969	167969												

# F/A-18E/F/G SUPER HORNET LOW VIZ DATA SET

1/48

F/A-18E  
SUPER HORNET

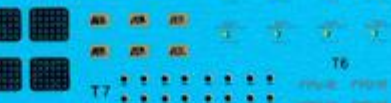
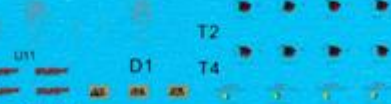
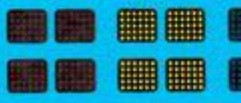
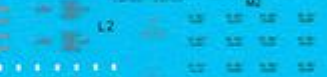

FRONT VIEW (1/48)

FRONT VIEW (1/48)

FRONT VIEW (1/48)

FRONT VIEW (1/48)

A3 A2 A1

A3 A2 A1

A3 A2 A1

A3 A2 A1

A3 A2 A1