

eduard

LIMITED

1/48



MIDWAY

F4F-3 and F4F-4 Wildcat from December 1940
to June 1942

INSTRUCTIONS SHEET

DUAL COMBO

11166-NAV1



The Wildcat at Midway

by Tom Cleaver photo: U.S. Navy

British experience with the Martlet I in combat led the Admiralty making a request to Grumman for the addition of folding wings to allow more Martlets to be carried aboard ship, and for an increase in weight of fire. The primary opponent of the British Martlets was the German Fw 200 Condor, and the weight of fire of four .50-caliber machine guns was insufficient to give good odds of a kill in the first pass, which was often the only pass in the confrontation.

In answering the demand for folding wings and increased weight of fire, Grumman was faced with the problem that they would be adding additional weight to a fighter whose performance was already compromised by lack of power, without an option to change up to a more powerful engine. Thus, what weight was added had to be minimized to the extent possible.

In the end, this weight saving was found in the armament. While two additional machine guns were added, the total ammunition load would remain the same; it was the only place where any significant weight could be saved. Thus, the redesign would redistribute the ammunition from the 450 rounds per gun of the F4F-3 to 250 rounds per gun in what became the F4F-4.

When more is not better

The F4F-3's four .50 in (12.7 mm) guns and 450 rpg gave the pilot 34 seconds of firing time; the reduction to 240 rpg in the F4F-4 gave a total firing time of 20 seconds. VF-3's Lt Cdr John S. Thach said of this change: "A pilot who cannot hit with four guns will miss with eight."

Grumman used its newly-developed "Sto-Wing" wing folding system, in which the outer wing was folded to the rear while being rotated to a near-vertical position, which allowed more of the wing to be folded than would be the case with a vertical-folding wing which would be limited by the height of the hangar overhead aboard an aircraft carrier. The system allowed five F4F-4s to be parked in the same space taken by two F4F-3s. In practice, this allowed a 50 percent increase in the number of Wildcats carried in a fleet carrier. Squadrons were increased from 18 to 24, a useful increase that had been shown useful in early combat when the limited number of fighters meant that a strike force was not effectively escorted while there were insufficient defenders for the carrier.

The weight of additional guns and folding wings without an increase in power reduced performance: the F4F-3's top speed of 330 mph was reduced to 318 mph in the F4F-4. Grumman optimistically claimed that rate of climb declined from the F4F-3's 2,303 feet per minute to 1,950 fpm in the F4F-4; however, in combat conditions, pilots found the F4F-4 only capable of some 500 to 1,000 fpm depending on weather conditions. At

Guadalcanal, the defenders were generally able to get a two-hour warning of inbound attackers through the coastwatchers in the Solomons; once fighters were manned and airborne, there was generally some 60-70 minutes before the Japanese arrived overhead. Marion Carl recalled that "it took every minute" to drag the F4F-4 to 24,000 feet, where the Marines could initiate their attack on an enemy formation flying between 18-20,000 feet. Carl compared the overall performance of the F4F-4 as similar to that of the equally overweight and underpowered Brewster F2A-3.

The XF4F-4 appeared in December 1941, and Grumman switched to production of what would be the major combat version of the Wildcat in January 1942. VF-6 aboard USS Enterprise (CV-6) was the first to re-equip with the new Wildcat on the ship's return to Pearl Harbor after the Doolittle Raid in late April 1942. During May 1942 the other fleet fighter squadrons re-equipped with F4F-4s as they arrived in Hawaii. Yorktown, which only returned to Pearl on May 27 from the Battle of the Coral Sea, saw her regular Air Group Five combined with squadrons from Air Group Three, which had been sidelined by the torpedoing of Saratoga back in January. Lt Cdr John S. "Jimmy" Thach, who had spent the previous six weeks training new aviators assigned to Fighting Three in how to fly his "Thach Weave" defensive maneuver, brought 25 new F4F-4 Wildcats to the carrier, where 11 of VF-3's most experienced pilots and 16 VF-42 Coral Sea Veterans would man them.

Seven of VF-6's F4F-3As were quickly reconditioned and sent on to VMF-221 on Midway, to supplement their F2A-3 fighters, arriving on May 26 aboard the aircraft ferry USS Kitty Hawk along with the VB-6 SBD-2s that went to VMSB-241. Both squadrons had only nine days to become familiar with their new mounts before they entered the crucible of combat; the Wildcats were given to the most experienced pilots in the squadron.

Gathering clouds

While American codebreakers had been reading the Japanese JN-25 code successfully since early 1942, the Japanese issued a new code book on May 24; however, it was not uniformly in use until May 27, which marked the last date the U.S. Navy would ever "read the enemy's mail" for the rest of the Pacific War. Fortunately, HYPO - the Pacific Fleet's codebreakers - had been able to obtain all needed information, including the Imperial

Navy's Order of Battle and the expected attack date: June 4, 1942. While the Americans knew everything, they needed to know about their opponent, the Imperial Navy had no warning, and no idea, of what lay in wait.

Dawn came to the Central Pacific the morning of June 4, 1942, revealing clear weather over the four carriers of *Kidō Butai*, with building clouds of a storm front to the east and northeast. The carriers began launching the first strike at 0430 hours: 36 D3A1 dive bombers, accompanied by 36 B5N bombers loaded for level bombing rather than torpedo attacks, escorted by 36 A6M2 Zeros. At almost the same time, 11 PBV Catalinas took off from Midway to search north, west and south of the atoll. At 0534 hours, a PBV sighted Akagi and Kaga through the scattered clouds and radioed a report. Ten minutes later, another Catalina reported the inbound airstrike. At 0554 hours, Midway's radar picked the attackers, reporting: "Many planes, 93 miles, 310 degrees, altitude 11,000 feet."

At 0555 hours, the air raid siren's wail sent the defenders scrambling. VMF-221's Duty Officer, 2nd Lieutenant John C. Musselman Jr., raced along the line of revetments in the command post pickup truck, yelling "Get airborne!" At 0600 hours, the order was given for VMF-221 to scramble. Ten minutes later, 20 F2A-3s and three F4F-3s were airborne.

The 23 pilots of VMF-221, known as the "Fighting Falcons," were a mixed lot. Eight were recent flight school graduates who had arrived nine days earlier, another five recent flight school graduates had arrived in March, while the rest had flown off Lexington after failing to get to Wake Island as reinforcement on December 24, 1941. Four had seen aerial combat on March 10 when Captain John Neefus' division intercepted an H8K "Emily" from Kwajalein, which they managed to shoot down after a prolonged battle in which one F2A-3 was badly damaged by the heavily-armed flying boat.

Squadron leader 31-year old Major Floyd B. "Red" Parks, a trained dive bomber pilot had arrived on Midway in March and taken command of VMF-221 on May 8 after the original squadron commander, Lt. Colonel Ira L. Kimes, had become commander of Marine Aircraft Group 22. The night of June 3, Captain Kirk Armistead found his normally extroverted commander moody and distracted. When Armistead tried to cheer him up, saying "By this time tomorrow, it'll all be over," Parks replied, "Yeah, for those of you who get through it." Parks assigned 13 F2As of second and third division leaders Captains Daniel J. Hennessey and Armistead to orbit north of the island as reinforcement, while he led four F2A-3s of first division and Captain Robert E. Curtin's two fourth division F2As, along with Captain John F. Carey's three F4F-3 Wildcats; Carey's wingmen were Captain Marion E. Carl and 2nd Lieutenant Clayton M. Canfield. Two Wildcats were airborne on dawn patrol while the sixth and seventh of the war-weary fighters were grounded with mechanical problems. Parks' three divisions took a bearing of 320 degrees, directly toward the incoming strike. Hennessey and Armistead's eight took a heading of 310 degrees to allow for radar error and the chance the attackers might split and attack from different directions.

At 0612 hours, Carey's three Wildcats were at 14,000 feet when he sighted the enemy 40 miles north of Midway. The B5Ns were in a "vee of vees" at 11,000 feet, followed by the D3As at a slightly higher altitude while the Zeros were stepped-up behind the dive bombers; the Marines a clear shot at the bombers for at least the first pass. At 0614 hours, Canfield saw Carey make "a wide 270-degree turn, then a 90-degree diving turn." He then heard the electrifying "Tally-ho! Hawks at angels-twelve," and, after a slight pause, "accompanied by fighters."

Carey made steep dive for a "high side pass" and caught the lead bomber, waiting till it filled his gunsight; his long burst shredded the B5N and set it afire; the gunner's return fire cracked his windshield. An instant later, the bomber blew up. Carey turned to the next when suddenly he was raked by a burst of fire that hit his right knee and left leg. On the verge of passing out in excruciating pain, "I dove at about a 40-degree angle and headed for a large cloud about five miles away."

Canfield followed his leader, recalling, "I fired at the number three plane in the number three section until it exploded and went down in flames." An instant later, the Zeros hit him. "My Wildcat was hit on the right elevator, left wing and flap and just ahead of the tail wheel by three 20mm cannon shells. There was also a .30-caliber hole through the tail wheel and one that entered the hood on the right side about six inches up, passing just over the left rudder pedal and damaging the landing gear."

Canfield sought refuge in nearby cloud. Emerging moments later, the enemy was gone. "I went around the cloud in the opposite direction and joined up with Captain Carey again." The two flew unsteadily toward Midway as Carey kept losing altitude and falling behind. "I kept throttling back so he could keep up. His wounds kept him from working the rudders, and his plane was all over the sky."

They reached Midway under attack and prepared to land, at which point Canfield discovered his flaps were gone. "When the wheels touched the ground the landing gear collapsed and the plane slid along the runway. When it stopped, I jumped out and ran for a trench just as a Zero strafed my abandoned plane." Carey landed right behind and remembered "I ended up in a ground loop, as I had a flat tire and could not control the plane because of the wound in my leg." Carey crashed into a revetment and was pulled out and dragged to safety with the bombs falling.

Left behind by Carey and Canfield, Marion Carl rolled into an overhead pass against the bombers. "I caught sight of these damn Zeros ... The air was full of them!" He made a high-side firing pass on one; when he looked back, "I was surprised to see several Zeros swinging into position on my tail, so I dived straight down at full throttle, then zoomed back up to 20,000 feet." As he headed back toward Midway, he spotted three Zeros below. "They didn't see me drop astern. I gave one a long burst, until he fell off on one wing out of control and headed almost straight down with smoke streaming from the plane."

"I looked around and couldn't find a friendly airplane any place and the next thing I know, I've got a Zero on my tail that's shooting away. I headed for a cloud, chopped the power, and threw the plane into a skid. When I came out the other side, the Zero had overrun me. I pulled the trigger on my guns and got nothing! My guns had jammed, but the maneuver scared him so badly that he gave up the fight." Despite being badly shot up, Carl was able to limp back and land safely.

The three Wildcats were lucky. Major Parks was hit by the swarming escorts early in the fight. Parks bailed out and his parachute was seen to open. A Zero pilot strafed him and then strafed his body when it fell on one of the outer reefs. All six pilots of Parks' first division were shot down. The 20 F2A-3 pilots were not only outnumbered by the 36 Zeros, they were completely outclassed by the faster and more agile enemy fighters, whose experienced pilots quickly shot down 16 Buffalos and one of the patrolling Wildcats, with 14 Marines killed in action. Four crash-landed on Eastern Island and six managed to land after the air raid was over. Only two planes were fit to fly again. VMF-221 was out of action. The 23 pilots were each awarded the Navy Cross, all but nine posthumously. Their opponents that morning were seasoned veterans of what was at the time the most effective naval air arm in the world, flying the best carrier-based fighter in the world. Against these losses, the Japanese admitted loss of seven B5N2s and two A6M2s.

Major Parks' citation reads: "For extraordinary heroism and conspicuous devotion to duty as Squadron Commander for Marine Fighting Squadron TWO TWENTY ONE, in action against enemy Japanese forces during the Battle of Midway, June 4, 1942. Leading his squadron in a dauntless and aggressive attack against a vastly superior number of Japanese bomber and fighter planes, Major Parks aided in disruption the plans of the enemy and lessening the effectiveness of their attack, thereby contributing materially to the success of our forces. As a result of his courageous and daring tactics and because of the circumstances attendant upon this engagement, there can be little doubt



Fighting Three's Lt Cdr John S. Thach spent a year refining his "Thach Weave" defensive maneuver that allowed the F4F to successfully confront the A6M2 Zero in combat.

Fighting Five's Commander James H. "Jimmy" Flatley





Lt Scott McCusky of VF-6 was the first F4F pilot to shoot down a Japanese airplane during the Kwajalein strike in February 1942.

that Major Parks gallantly gave up his life in the service of his country. He displayed the characteristics of a fine leader and excellent airman in keeping with the highest traditions of the United States Naval Service."

Captain Phillip R. White complained bitterly in his after-action report: "The F2A-3 is not a combat aircraft. It is inferior to the planes we were fighting in every respect. It is my belief that any commander who orders pilots out for combat in a F2A-3 should consider the pilot as lost before leaving the ground."

Battle rages on

For their actions at Midway, the Marines of MAG-22 were awarded the Presidential Unit Citation. Admiral Nimitz recognized the Marines' contribution to victory at Midway as follows: „Please accept my sympathy for the losses sustained by your gallant aviation personnel based at Midway. Their sacrifice was not in vain. When the great emergency came, they were ready. They met, unflinchingly, the attack of vastly superior numbers and made the attack ineffective. They struck the first blow at the enemy carriers. They were the spearhead of our great victory. They have written a new and shining page in the annals of the Marine Corps."

Aboard the three American carriers cruising at "Point Luck," the crews had been awakened at 0130 hours and fed between 0300-0400 hours to give them time to prepare. Surprisingly, Yorktown, the only carrier of the three whose leaders had direct combat experience, was held back in reserve while Enterprise and Hornet, which had yet to engage an enemy carrier, were assigned to make the maximum-effort strike.

At 0534 hours the Catalina search plane reported "Carriers sighted." At 0553 hours came the report, „Many planes heading Midway." Finally, at 0603 hours, the Catalina reported „Two carriers and battleships bearing 320 degrees, distance 180, course 135, speed 25." Quick calculations placed the enemy fleet 175 miles west-southwest of the Americans. In fact, the position report was incorrect; the enemy was now 200 miles away. Those extra miles would matter. At 0607 hours, Admiral Fletcher aboard Yorktown ordered Spruance's two carriers to attack. „Proceed southwesterly and attack enemy carriers as soon as definitely located." Spruance considered that while the reported range was extreme, a strike could succeed. Chief of Staff Miles Browning determined that because they would have to turn away to launch that they should wait until 0700 hours, giving them an hour to close the distance a further 25 miles, placing the enemy about 155 miles distant. Spruance agreed and Enterprise and Hornet began launching at 0656 hours. Where the Japanese had launched 108 aircraft from four carriers in only seven minutes, Enterprise and Hornet required more than an hour to launch 117.

The Enterprise Dauntlesses were airborne by 0725 hours forming up and climbing in circles above the carrier. Twenty minutes after the dive bombers launched, the first VF-6 Wildcat escort was launched, followed by VT-6's 18 slow TBDs. By the time the TBDs were airborne and assembled under the leadership of Lt Cdr Gene Lindsey, the SBDs were distant on the horizon. At this point, the VF-6 Wildcats mistakenly took up position over Hornet's Torpedo Eight, leaving Torpedo Six without fighter escort.

Hornet's air group also broke up shortly after CAG Cdr Stanhope Ring took up his westerly heading of 265 degrees at the head of the dive bombers. Torpedo Eight's Lt Cdr John Waldron, who still believed his course information was correct, signaled his pilots to follow him and took up what he had determined was the most direct course to the enemy, taking a heading of 240 degrees. The VF-6 F4F-4s followed.

Fortunately, Admiral Fletcher decided to commit Yorktown's air group to launch at 0838 hours. The combat-experienced Air Department ordered the squadrons to execute a „running rendezvous". Lt Cdr Lance Massey's slow Torpedo Three TBDs were launched first and headed off at low altitude. Bombing Three and Scouting Five, led by VB-3's LCDR Max Leslie, launched next, while John Thach's eight F4F-4 Wildcats launched last.

Having taken the most direct course to the enemy, Waldron spotted Kidō Butai shortly after he spotted smoke on the horizon at 0925 hours. His guess the enemy would make a turn to the north had been right.



VF-8 F4F-4 Wildcat ready to take off while other aircraft are positioned to the side.

Unfortunately, his call to Stanhope Ring that he had found the fleet came too late. The Hornet CAG took the SBDs and their escorting F4F-4s to maximum range and missed the Japanese entirely. Prewar carrier doctrine called for a strike force in this position to return to the nearest friendly land base. In this case, that meant Midway, which was in no condition to receive the strike force. Ring had required a "parade ground" formation, which meant increased gas usage; it was now questionable the formation had the fuel to get to Midway. Some SBDs and F4Fs tried to return to Hornet, while the others headed toward Midway. While most of the dive bombers made it; only two of the 10 Wildcats returned. Ring's decision removed Hornet from the battle and nearly cost Marc Mitscher his career, had he not already received notice of promotion to Rear Admiral.

Torpedo Eight had been spotted by the Japanese scout that had spotted the American carriers; the enemy was waiting for them when they got to the fleet. The Zero CAP fell on the TBDs. Waldron was one of the first shot down. In the next five minutes, all but one crashed into the sea with no survivors. Ensign George Gay dropped his torpedo; as his plane struck the water, the hood slammed shut. The TBD tipped for its final dive as Gay struggled to open the canopy. "I couldn't hardly get it open. That's when I got scared." Finally, the hood slid back and he scrambled out. He was left bobbing in the sea; a moment later, his seat cushion popped to the surface.

VF-6 commander Lieutenant John Gray had become separated from both his VT-6 and VT-8. The Wildcats arrived on the far side of the enemy fleet and waited for the call for assistance from Torpedo Six's Gene Lindsey as they orbited 15 miles on the opposite side of the fleet from the torpedo bombers they were charged with protecting. The VT-6 bombers arrived on the wrong side of the formation; Lindsey's division was spared the attention of the CAP as they flew around the enemy formation, but were finally caught by the Zeros as they began their run in. He and three others were shot down, while the other three managed to drop their torpedoes and escape to return to Enterprise. The second division chased Kaga as the CAP slashed at them, taking them down one-by-one. Finally, only the TBDs flown by Aviation Machinist's Mate 1/c A. Walter Winchell and Chief Aviation Machinist Stephen B. Smith were still flying, both damaged. They both dropped their torpedoes and managed to escape the fire. Smith made it back to Enterprise, while Winchell and gunner Aviation Radioman 3/c Douglas M. Cossit were forced to ditch, surviving 17 days in their raft until they were rescued by a PBY on June 21.

The 12 TBDs of Yorktown's VT-3, led by Lt Cdr Lance "Lem" Massey, escorted by six F4F-4 Wildcats led by John S. Thach, found the enemy a matter of minutes after the Enterprise SBDs made their devastating attack on Kaga and Akagi, just as Lt Cdr Max Leslie led 36 dive bombers nosed over to attack Sōryū. Yorktown's strike was the only air group to make a coordinated attack.

Thach recalled they had only a few hops to get used to the new F4F-4. VF-42's Jim Adams recalled, "We went from bad to worse when we picked up the F4F-4 for Midway. We had all kinds of extra weight and a real sluggish aircraft; six guns and less firing time. The reduction in rounds per gun with the increase from four to six guns cut the firing time by six seconds. That doesn't sound like much, but it can be a lifetime in combat."

Thach's formation included his wingman, Ensign Robert A. M. „Ram" Dibb, with VF-42's Lt (jg) Brainard Macomber and wingman Ensign Edgar Bassett. Aviation Machinist Mate 1/c Tom Cheek and his wingman, Ensign Daniel Sheedy, were just astern of the TBDs, all about 1,000 feet above the bombers, flying at 750 feet. Thach later remembered, "We had to do S turns, so we wouldn't run away from the TBDs and we didn't want to be stalling along with no ability to maneuver in case something hit us before we anticipated it. We were flying our standard combat formation and were weaving."

"Looking ahead, I could see ships through the breaks in the clouds, and I figured that was it. We had just begun to approach about ten miles from the outer screen of this large force, it looked like it was spread over the ocean, and several colored antiaircraft bursts appeared in our direction, one red and another orange, and then no more. I wondered why they'd be shooting at us because we weren't even nearly in range. We'd been sighted by the surface screen and they were alerting the combat air patrol. A very short time after,

before we got near anti-aircraft range, Zero fighters came down on us. I tried to count them and I figured there were 20.

"The first thing that happened was Bassett's plane was burning. He pulled out, and I didn't see him anymore. He was shot down right away. I was surprised they put so many Zeros on my six fighters. But then I saw they had a second large group that was now streaming in right past us and into the poor torpedo planes.

"Macomber's position was too close to me to permit an effective weave, and I was not getting very good shots at the Zeros. I called him on the radio and said: 'Open out more. About double your present distance and weave.' No acknowledgment. His radio was dead. How ironic this situation had become! I had spent almost a year developing what I was convinced was the only way to survive against the Zero, and now we couldn't seem to do it! I couldn't see Cheek and Sheedy so I called Ram Dibb, my wingman, and said, 'Pretend you are a section leader and move out far enough to weave.' He said, 'This is Scarlet Two, wilco.' His voice sounded like he was elated to get this promotion right in the middle of a battle.

"Several Zeros came in on a head-on attack on the torpedo planes and burned Lem Massey's plane right away. It just exploded in flames. And, beautifully timed, another group came in on the side against the torpedo planes. The air was like a beehive, and I wasn't sure at that moment that anything would work. It didn't look like my weave was working, but then it began to work. I got a good shot at two of them and burned them, and one of them made a pass at my wingman, pulled out to the right, and then came back. We were weaving continuously, and I got a head-on shot at him, and just about the time I saw this guy coming, Ram said, 'There's a Zero on my tail.' The Zero wasn't directly astern, more like 45 degrees, beginning to follow him around, which gave me the head-on approach. I probably should have decided to duck under this Zero, but I lost my temper. He just missed me by a few feet with flames coming out of the bottom of his airplane. This is like playing chicken with two automobiles on the highway except we were both shooting as well. That was a little foolhardy, I didn't try it anymore.

"Pure logic would convince anyone that with their superior performance and the number of Zeros they were throwing into the fight, we could not possibly survive. 'Well,' I said, talking to myself, 'we're going to take a lot of them with us if they're going to get us all.' We kept on working the weave, and it seemed to work better and better. I haven't the slightest idea how many Zeros I shot down. I just can't remember, I was absolutely convinced that nobody could get out of there, that we weren't coming back, and neither were any of the torpedo planes."

Japanese doom

As Thach weaved against the Zeros and all but three of the torpedo planes were shot down, the Yorktown dive bombers attacked Sōryū. Thach recalled: "I'd never seen such superb dive bombing. It looked to me like almost every bomb hit. Of course, there were some very near misses. There weren't any wild ones. About that time the Zeros slacked off. I could only see three carriers. One of them, probably either the Sōryū or the Kaga, was burning with bright pink and sometimes blue flames. I remember looking at the height of the flames noticing that it was about the height that the ship was long, just solid flame going up and a lot of smoke on top of that. I saw three carriers burning pretty furiously before I left; I picked up one torpedo plane and flew on back to the Yorktown with it. I was over the Japanese fleet a full 20 minutes." In six deadly minutes, the Japanese had lost Akagi, Kaga and Sōryū.

One Japanese carrier was left, the Hiryū. As the Americans departed, she launched 18 dive bombers and six Zeros at 1100 hours. At 1205 hours, they found Yorktown.

Aboard Yorktown, John Bridgers and the other pilots held back from the morning strike did their best to stay out of the way. "The planes from the fourth Japanese carrier found the Yorktown before we found their ship and, in short order, we were under attack. We pilots had no duties other than to sit in our ready room. Unable to see out, we became more and more tense with no activities to release the tension. This was by far the toughest experience I had during the war. Our anti-aircraft guns began shaking the ship, and we figured enemy planes were closing in. In steel ships, there were many plates to rattle and reverberate, so the firing of guns was a noisy din indeed. Most of us gathered around the plate patching the ready room deck after one fellow said, 'Surely lightning won't strike twice in the same place!' The response was 'But do you think the Japs know that?' Just as quickly, we dispersed to our empty desk-seats, and in short order the ship was struck by a couple of bombs. Since the overhead of our ready room was the underside of the flight deck above, we felt considerable jolts and the lights blinked out, to be automatically replaced by the dim red glare of battle lamps, and smoke was immediately evident. The attack passed quickly. In a few minutes, we were released to move topside and survey the damage. By now, our ship was dead in the water."

The defending Wildcats had fought one of the wildest battles of the Pacific War. One pilot recalled that as he left the flight deck, an enemy torpedo bomber was in front of him and he shot it down before he could retract his gear.

Once on the flight deck, Bridgers was immediately confronted with war's cost when he saw bodies covered with tarpaulins. Yorktown was soon able to get underway and land planes; then came warning of a second strike. "After the first attack, I observed that many had been injured because they were standing around upright and were either hit by flying debris or knocked up against projecting fittings. This must have been something noticed by the others, for all of us immediately lay down prone on the deck — a precaution well worthwhile. Next, there was a tremendous explosion and I was lifted bodily what felt to be a foot or more off the deck. I now knew what a torpedo hit felt like. Almost immediately, it was evident that the ship was listing to one side and was once again dead in the water. Word was passed to abandon ship. Large life rafts were thrown over the side and the grim business got underway. I walked around the island and across the deck, trying to decide when I would go, secretly hoping someone would change their mind about the whole affair. I passed Captain Buckmaster taking a turn around the deck and he told me to hurry and get off the vessel. In several minutes, I passed him again and he said: 'Son, I thought I told you get off this ship. Now get moving!'" Bridgers was soon in the water.

Summing up Spruance's performance, naval historian Samuel Eliot Morison later wrote: "Fletcher did well, but Spruance's performance was superb. Calm, collected, decisive, yet receptive to advice; keeping in his mind the picture of widely disparate forces, yet boldly seizing every opening. Raymond A. Spruance emerged from the battle one of the greatest admirals in American Naval history."

There is a likely-apocryphal story in the U.S. Navy that the Battle of Midway has been replayed many times at the U.S. Naval War College in Newport, Rhode Island, and that each time the Americans lose. More than any other battle in World War II, the Battle of Midway was won as the result of a very fortunate combination of good intelligence, planning, and, most of all, luck. The American fleet was inferior to its Japanese opponents as regards numbers and combat experience yet was able to sink all four of the Imperial Navy's aircraft carriers committed to the battle.

Crewmen on deck of USS Yorktown after she was hit in the first strike by aircraft from the Japanese carrier Hiryū.



Adding wing-folding to the F4F-4 allowed the number of Wildcats aboard a fleet carrier to be increased by 50% over the non-folding F4F-3.



After being badly hit in the first Hiryū strike, Yorktown was able to get underway by the time the second strike arrived, and was torpedoed. The ship was now doomed and the crew was ordered to abandon ship.





Carefully read instruction sheet before assembling. When you use glue or paint, do not use near open flame and use in well ventilated room. Keep out of reach of small children. Children must not be allowed to suck any part, or pull vinyl bag over the head.



Před započítím stavby si pečlivě prostudujte stavební návod. Při používání barev a lepidel pracujte v dobře větrané místnosti. Lepidla ani barvy nepoužívejte v blízkosti otevřeného ohně. Model není určen malým dětem, mohlo by dojít k požití drobných dílů.

INSTRUCTION SIGNS * INSTR. SYMBOLS * INSTRUKTION SINNBILDEN * SYMBOLES * 記号の説明

OPTIONAL
VOLBABEND
OHNOUTSAND
BROUSITOPEN HOLE
VYVRTAT OTVORSYMETRICAL ASSEMBLY
SYMETRICKÁ MONTÁŽREMOVE
ODŘÍZNOUTREVERSE SIDE
OTOČITAPPLY EDUARD MASK
AND PAINT
POUŽIT EDUARD MASK
NABARVIT

PARTS



DÍLY



TEILE



PIÈCES



部品

PLASTIC PARTS

A> 2 pcs.

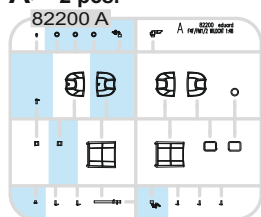

B> 2 pcs.

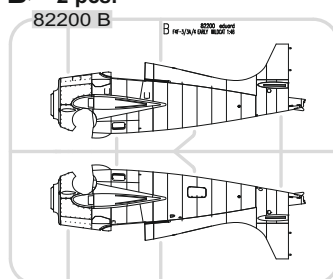

E>

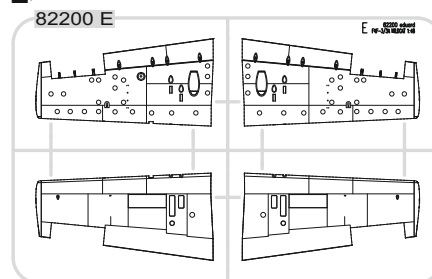

H>

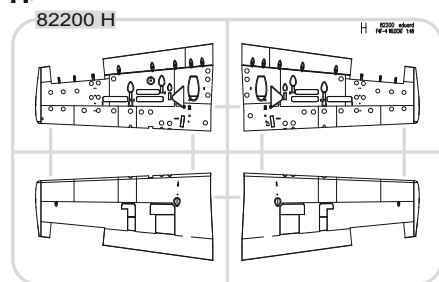

L> 2 pcs.

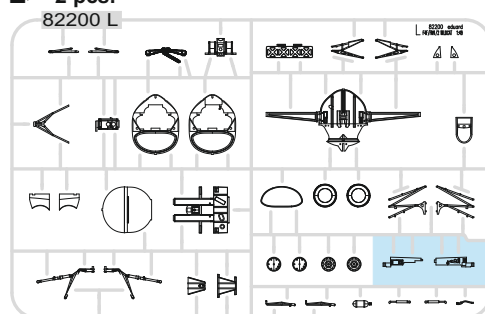

M> 2 pcs.

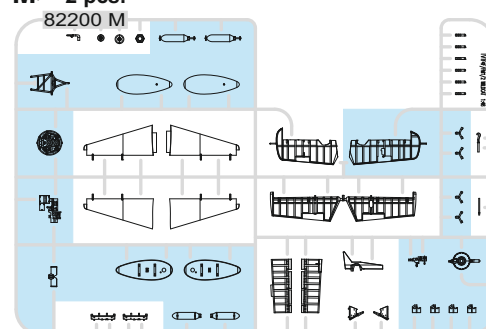

N> 2 pcs.

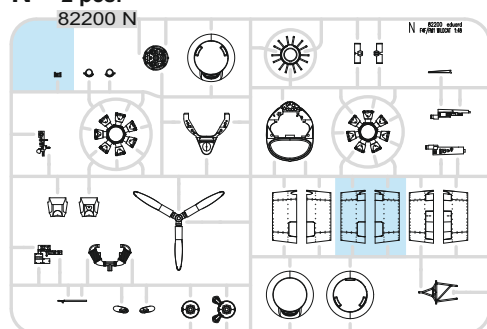

PE - PHOTO ETCHED DETAIL PARTS

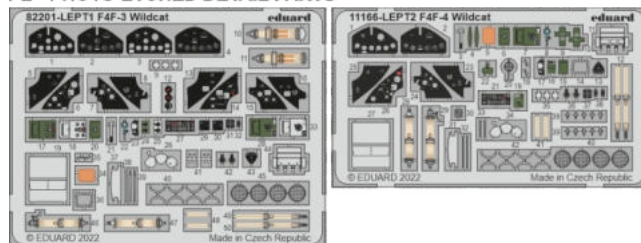
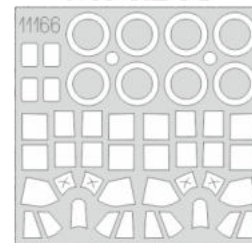
eduard
MASK

-Parts not for use. -Teile werden nicht verwendet. -Pièces à ne pas utiliser. -Tyto díly nepoužívejte při stavbě. - 使用しない部品

COLOURS



BARVY



FARBEN



PEINTURE



色

GSI Creos (GUNZE)		MISSION MODELS	
AQUEOUS	Mr.COLOR	PAINTS	
H1	C1	MMP-001	WHITE
H2	C2	MMP-047	BLACK
H6	C6	MMP-004	GREEN
H8	C8		SILVER
H12	C33	MMP-047	FLAT BLACK
H47	C41	MMP-012	RED BROWN
H52	C12	MMP-091	OLIVE DRAB
H58	C351	MMP-059	INTERIOR GREEN
H77	C137	MMP-040	TIRE BLACK
H85	C45	MMP-040	SAIL COLOR
H90	C47		CLEAR RED
H93	C50		CLEAR BLUE
H94	C138		CLEAR GREEN

GSI Creos (GUNZE)			MISSION MODELS
AQUEOUS	Mr.COLOR	PAINTS	
H306	C306	MMP-118	MEDIUM GRAY
H316	C316	MMP-104	WHITE
H325	C325	MMP-063	GRAY
H327	C327	MMP-101	RED
H329	C329	MMP-041	YELLOW
	C367	MMP-061	BLUE GRAY
Mr.METAL COLOR		METALLICS	
MC214		MMM-001	DARK IRON
MC218		MMM-003	ALUMINIUM
MC219		MMM-009	BRASS
Mr.COLOR SUPER METALLIC		METALLICS	
SM201		MMC-001	SUPER FINE SILVER

1 = 90% + 10%
 H58 MMP C351 059 INT. GREEN
 H12 MMP C33 047 FLAT BLACK
 H47 MMP C41 012 RED BROWN
 H8 C8 SILVER

H8 C8 SILVER - MARKING A ONLY

F4F-3

MARKINGS A, B, C, D, E

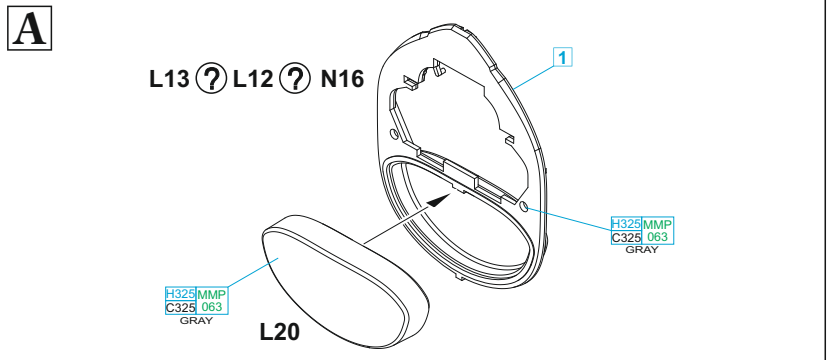
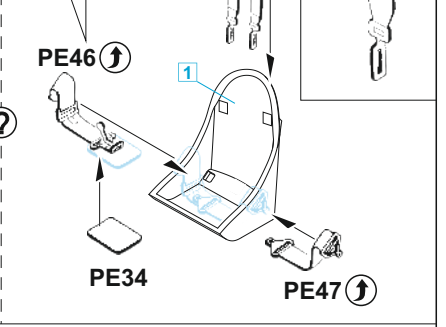
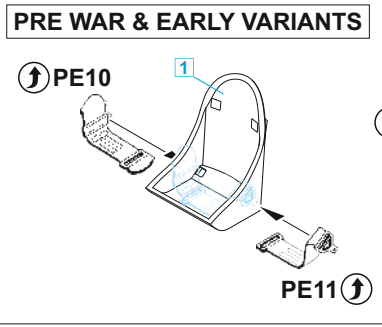
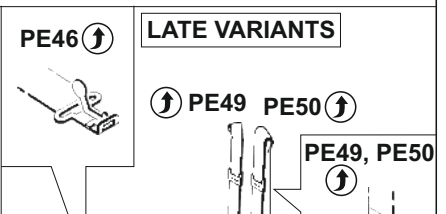
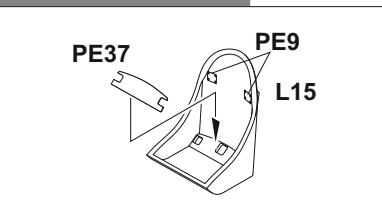
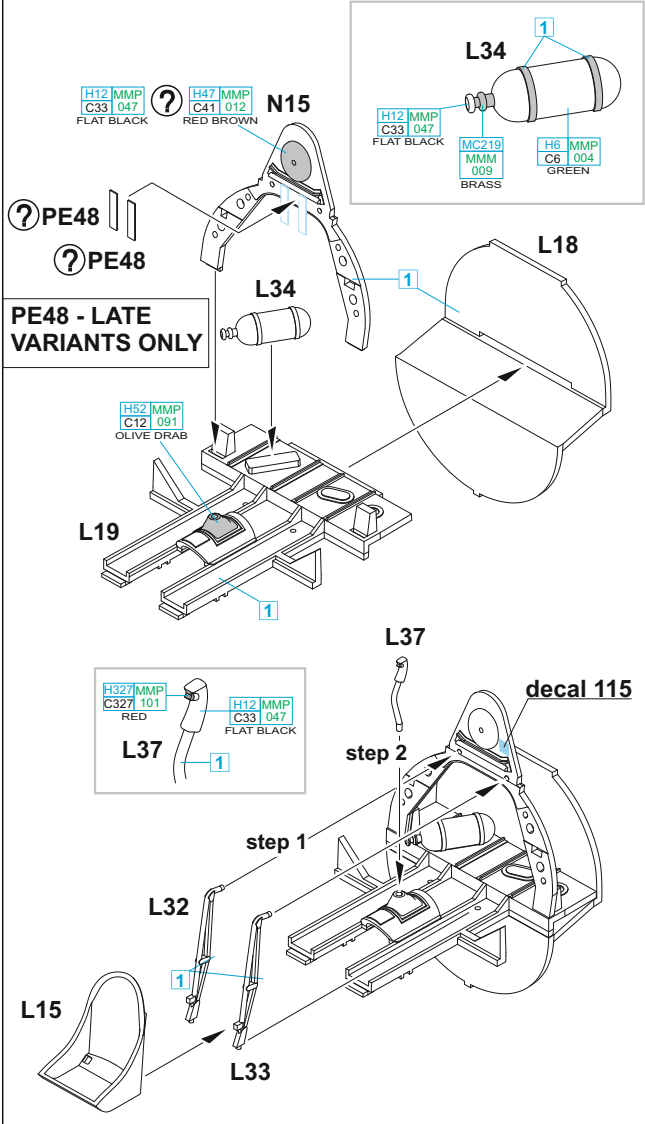

OPTIONAL:
 decals K1, K2, K3, K4, K5, K6

PE1, PE2, PE5, PE6, PE7, PE8 - MARKINGS B, C, D, E
 PE3, PE4, PE13, PE14, PE15, PE16 - MARKING A

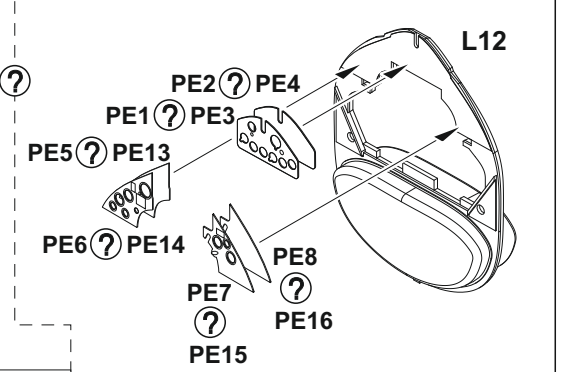
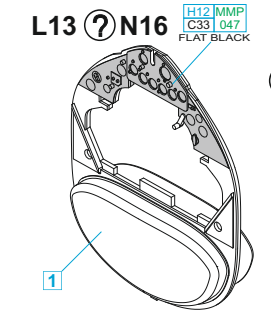

K1, K2, K3 - MARKING A
 K4, K5, K6 - MARKINGS B, C, D, E

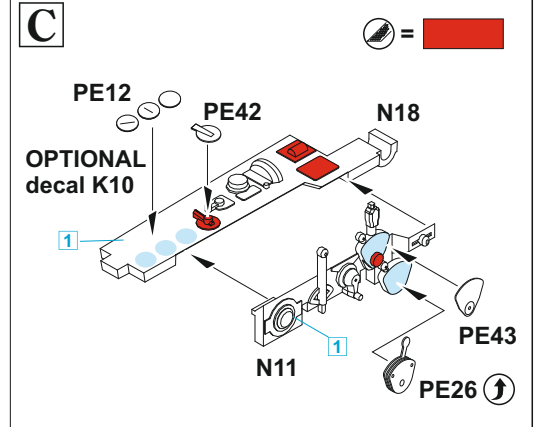
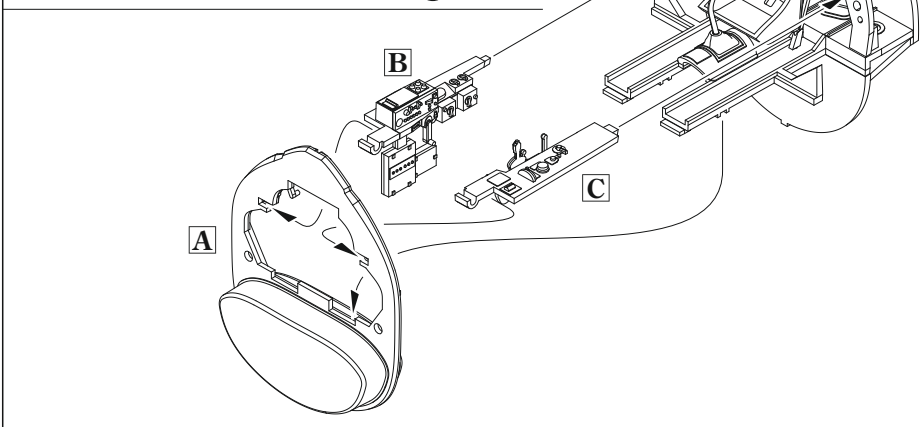
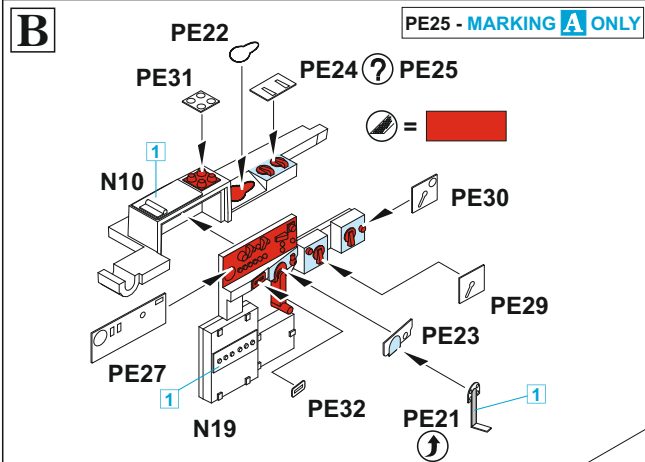

PRE WAR & EARLY VARIANTS

LATE VARIANTS

D

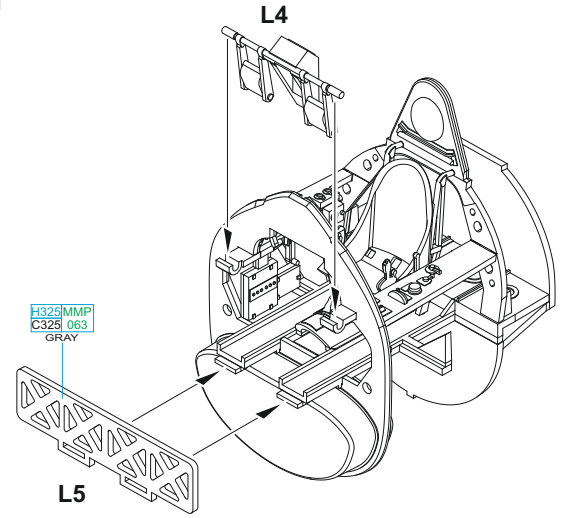
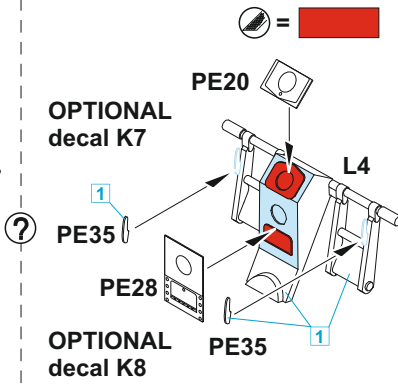
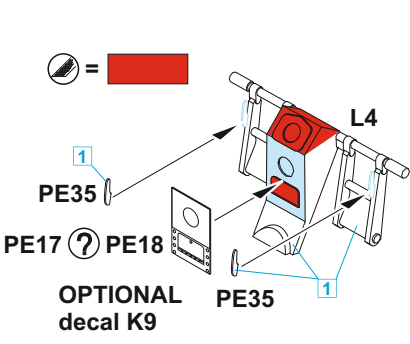

E

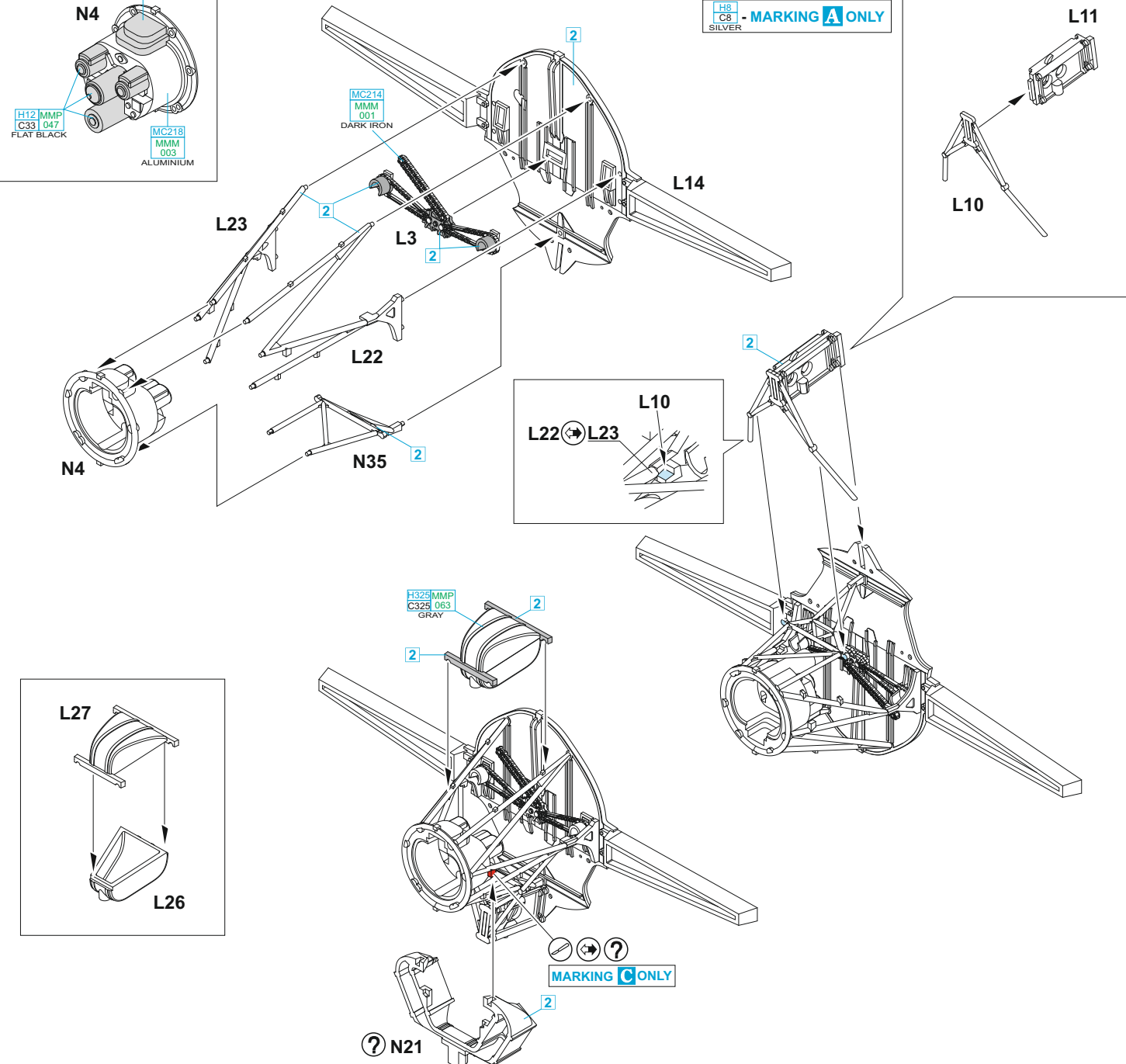
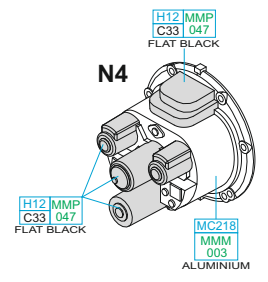

N21 - MARKINGS A, B, D, E ONLY

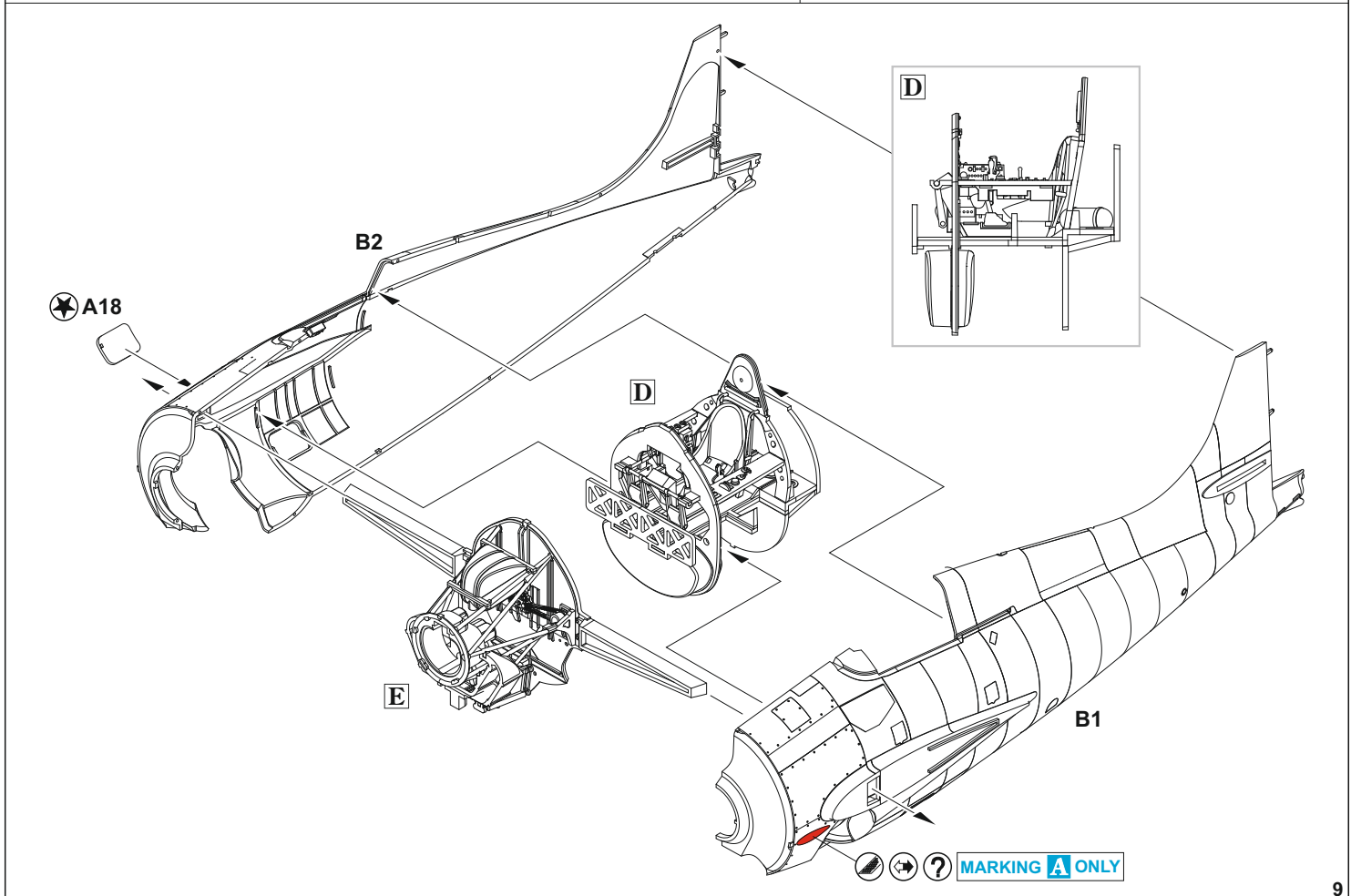
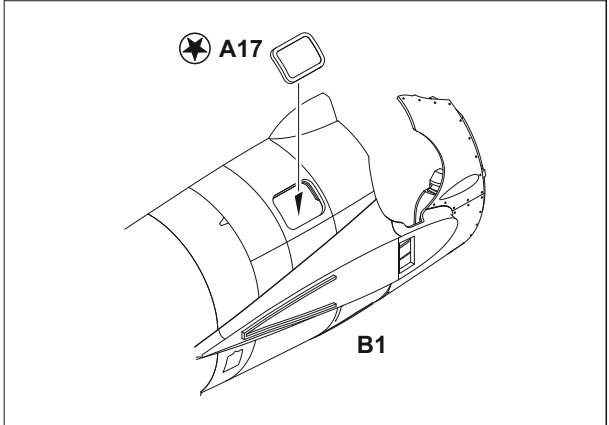
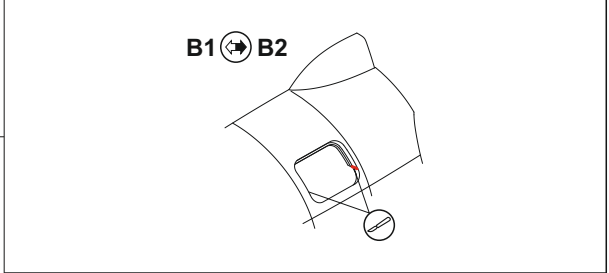
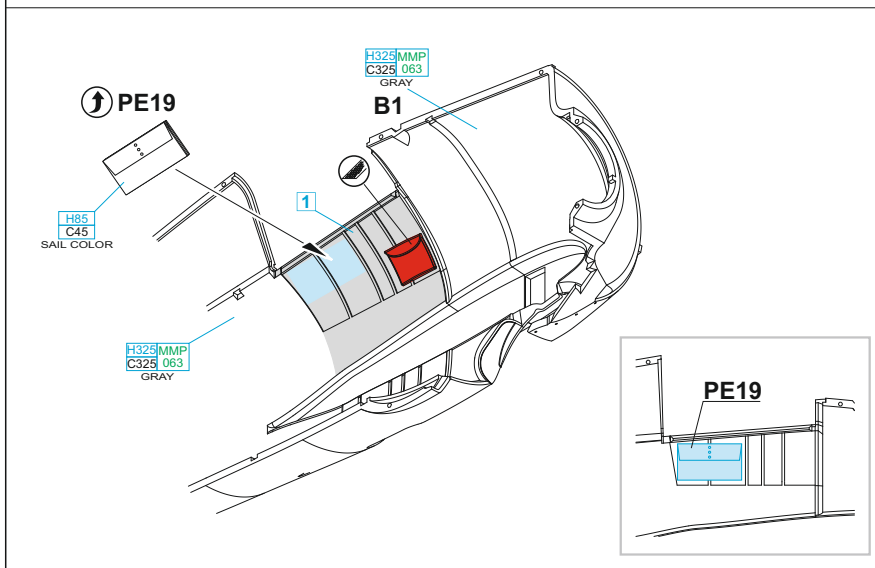
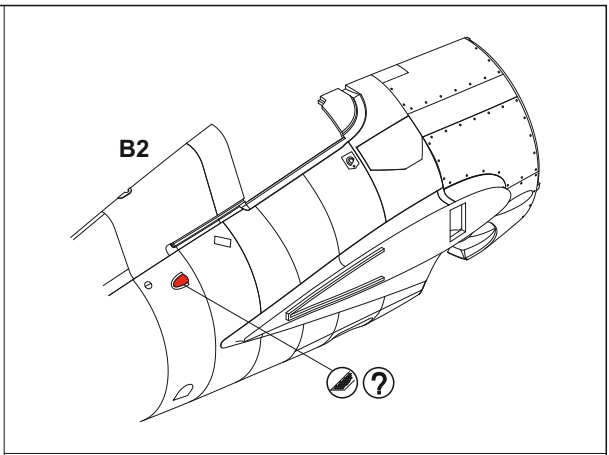
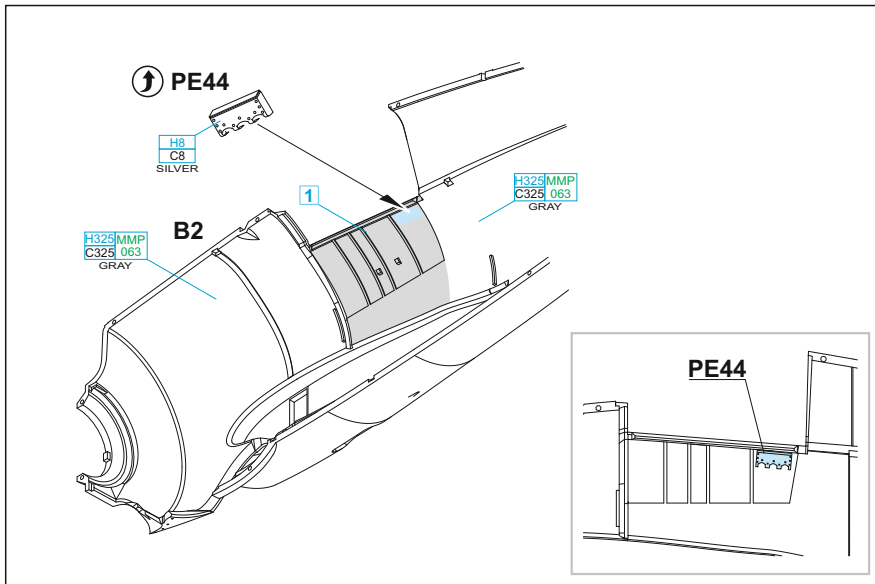

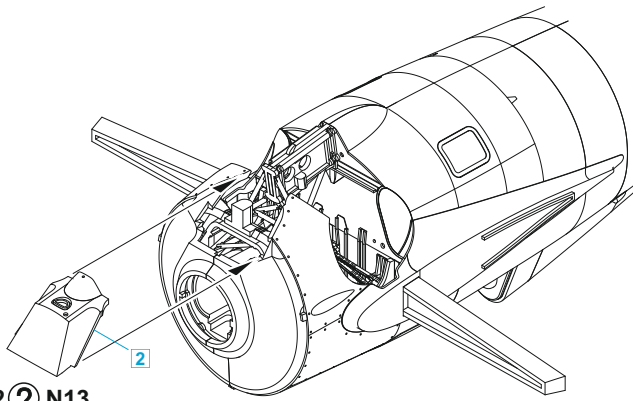

N12 ? N13

N12 - MARKING C ONLY

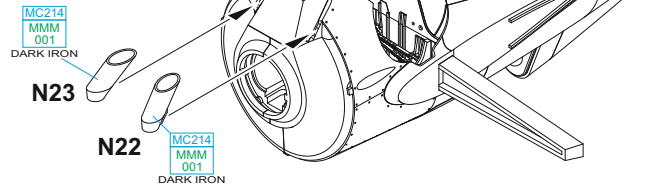

N23

N22

MC214
MMM
001
DARK IRON

MC214
MMM
001
DARK IRON

F

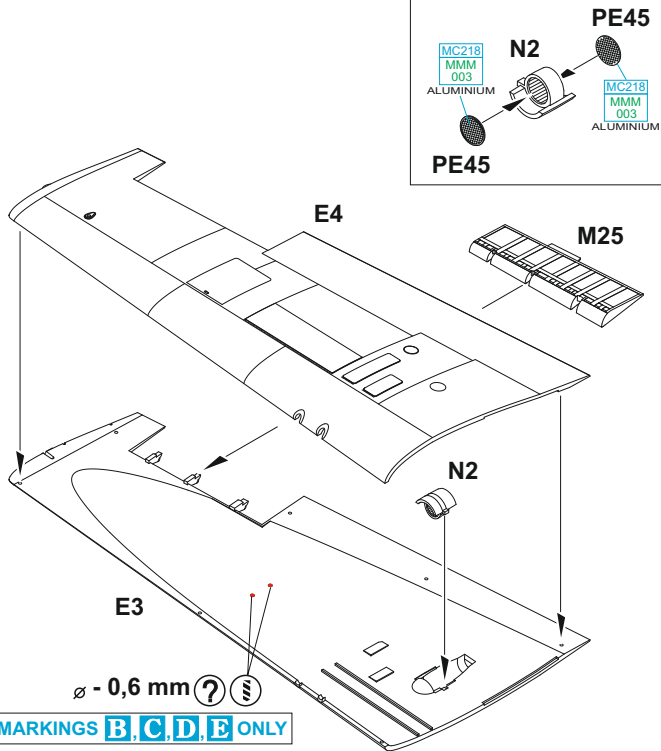

∅ - 0,6 mm ?

MARKINGS B, C, D, E ONLY

G

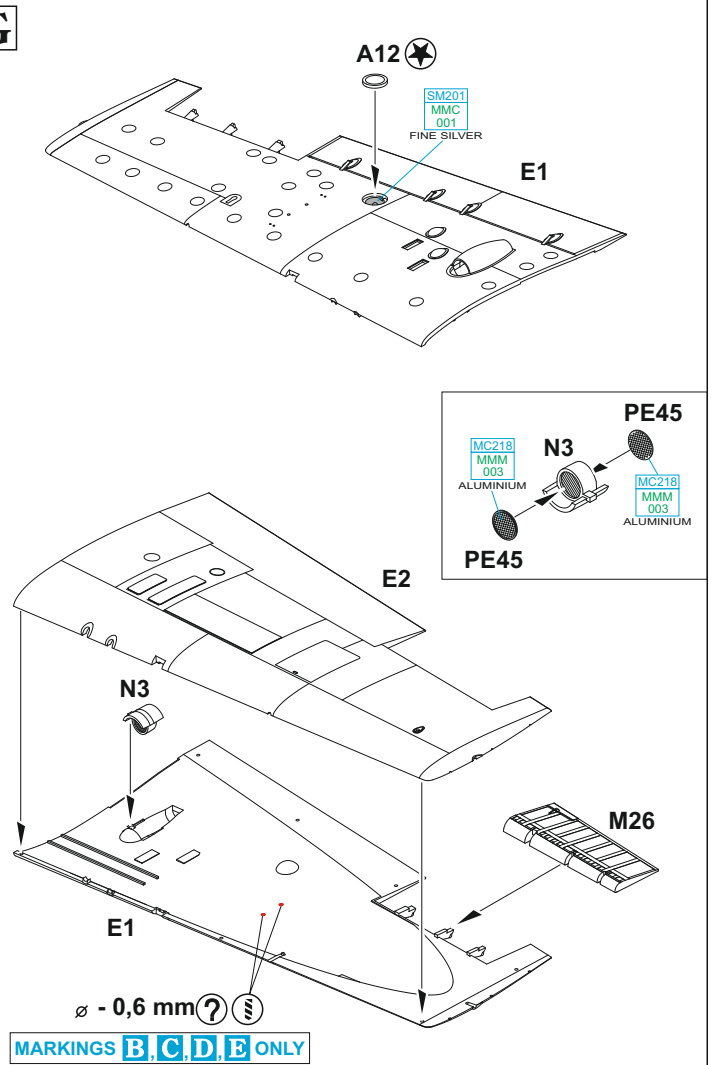

∅ - 0,6 mm ?

MARKINGS B, C, D, E ONLY

H

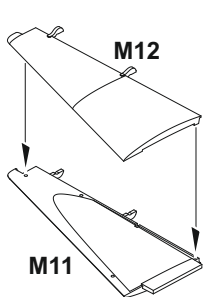

M11

M12

I

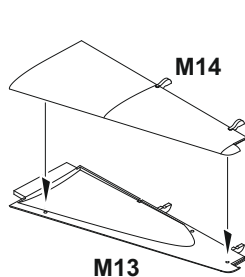

M13

M14

J

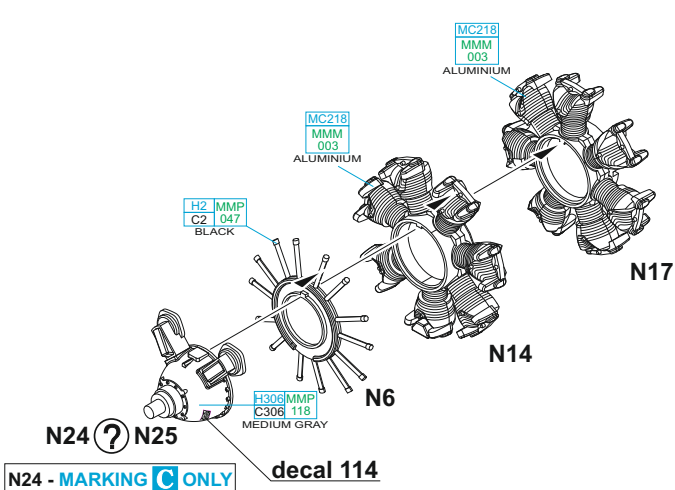

N24 ? N25

N24 - MARKING C ONLY

decals 114

K

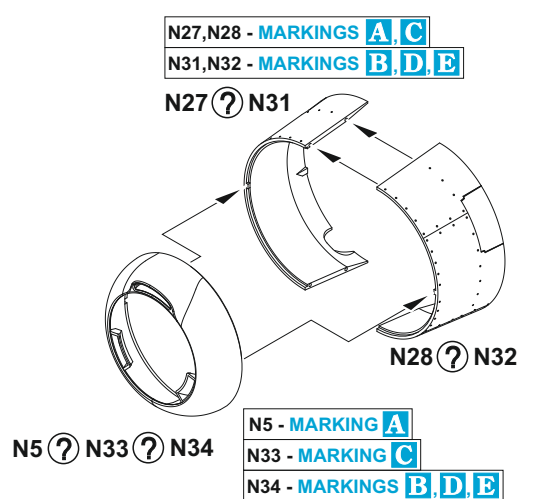

N27, N28 - MARKINGS A, C

N31, N32 - MARKINGS B, D, E

N27 ? N31

N28 ? N32

N5 ? N33 ? N34

N5 - MARKING A

N33 - MARKING C

N34 - MARKINGS B, D, E

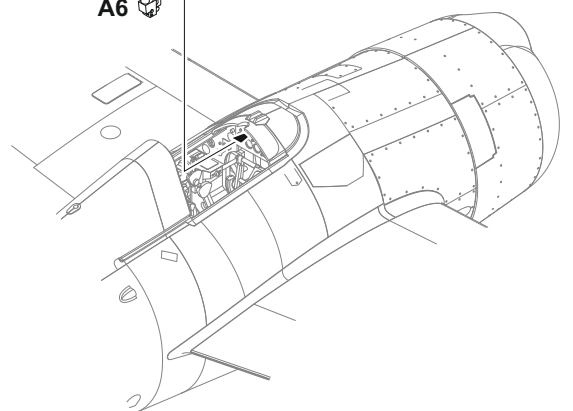
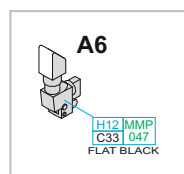
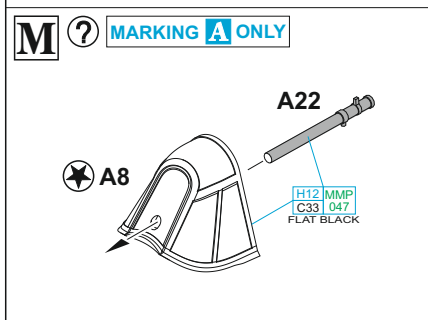
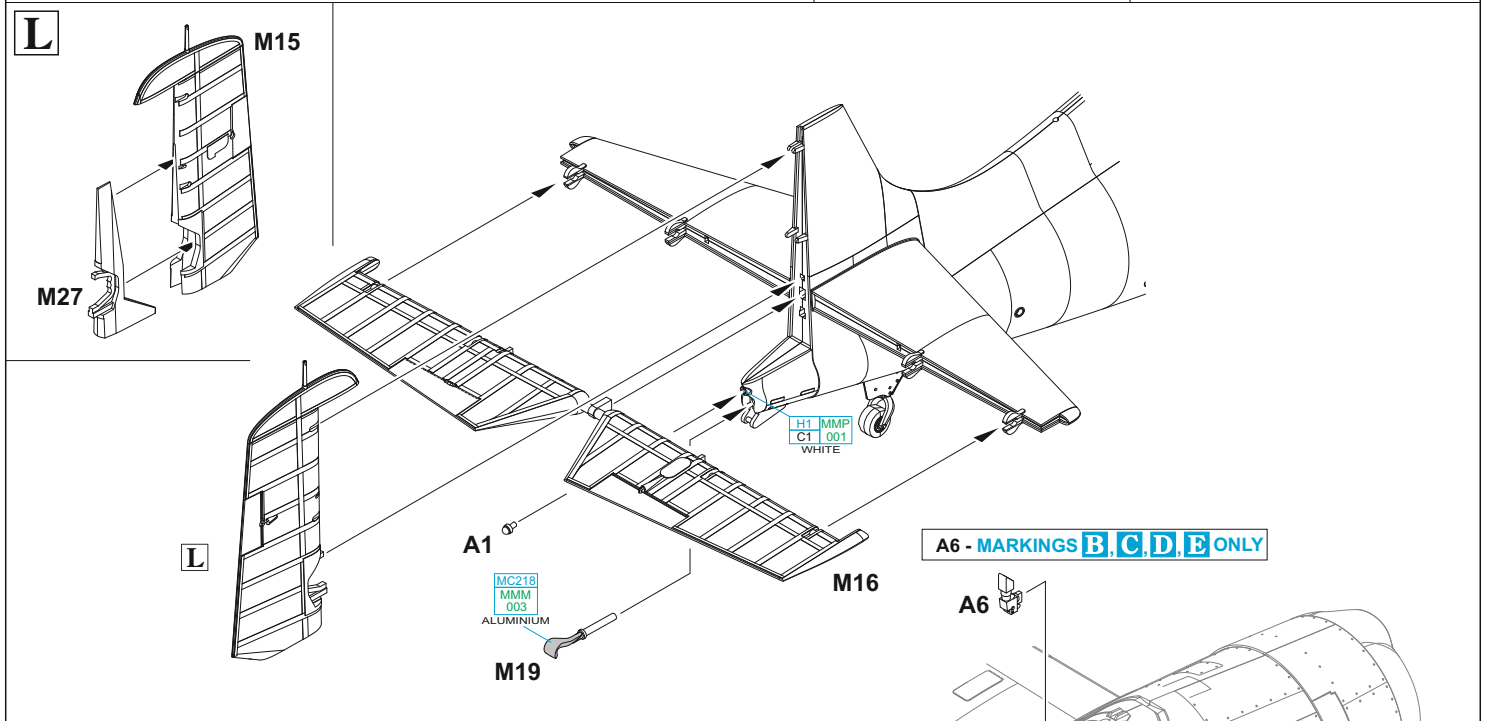
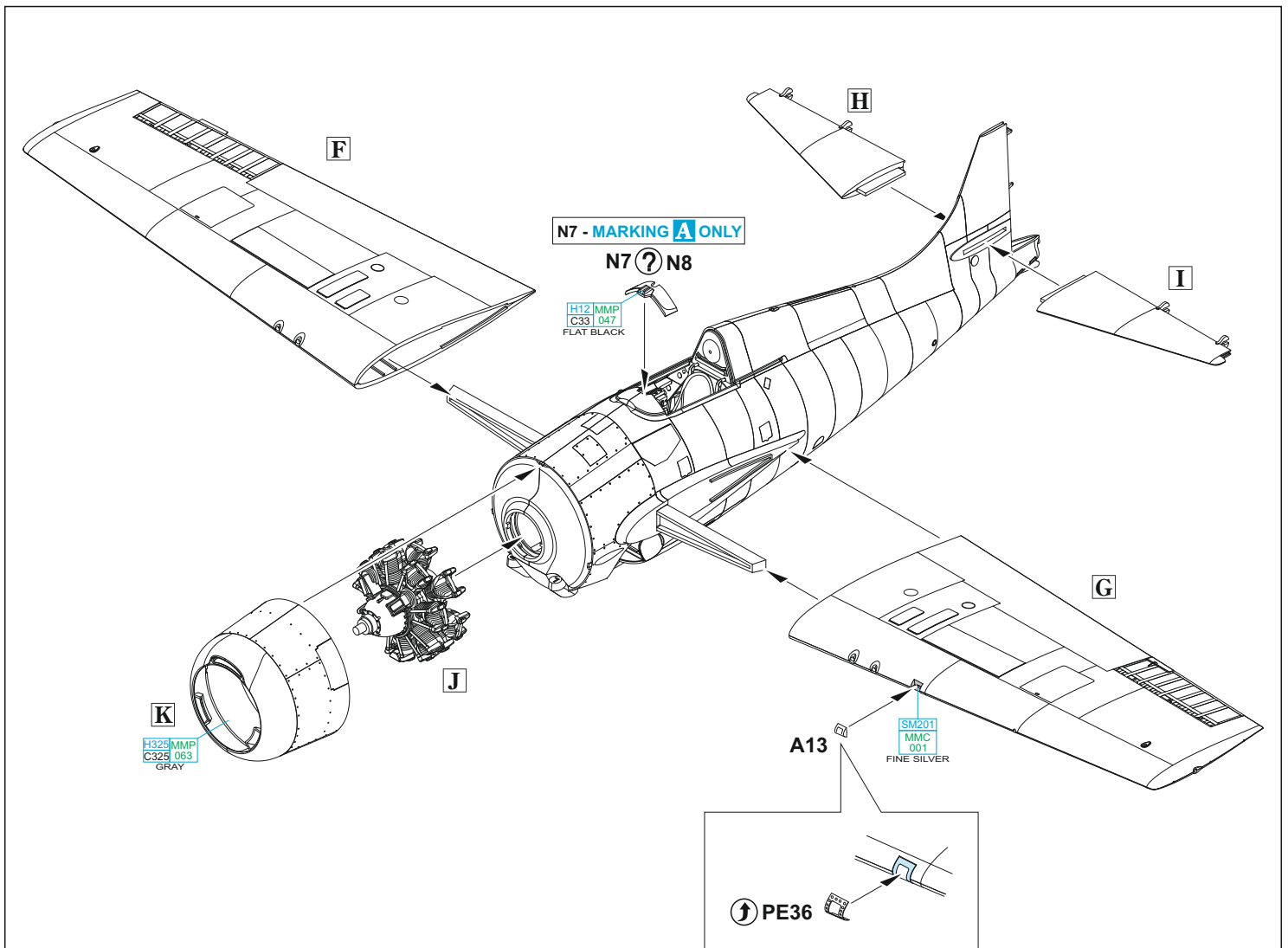

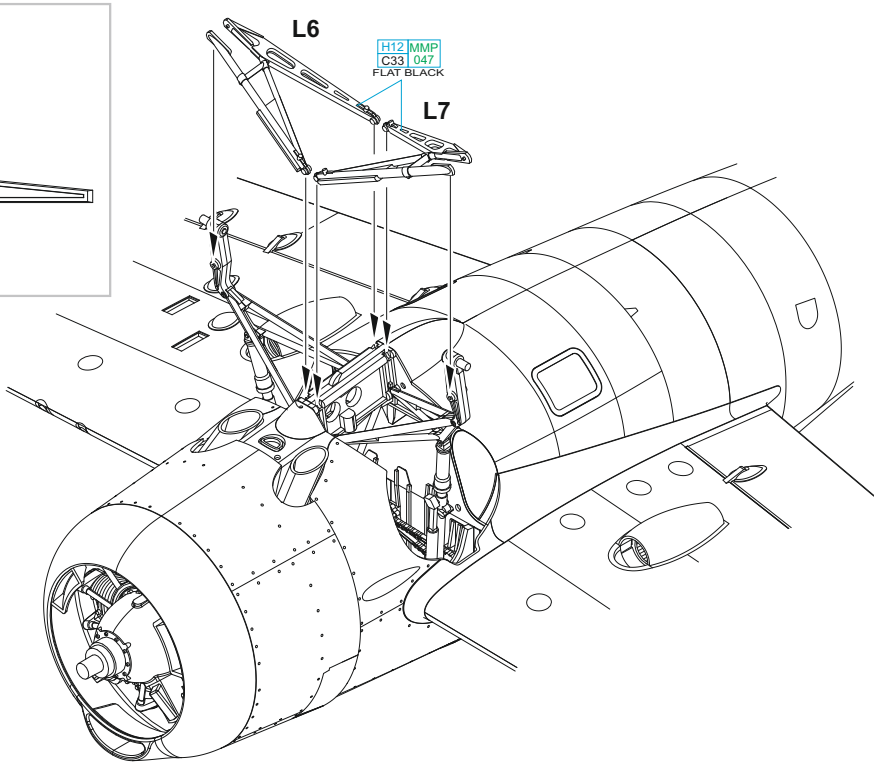
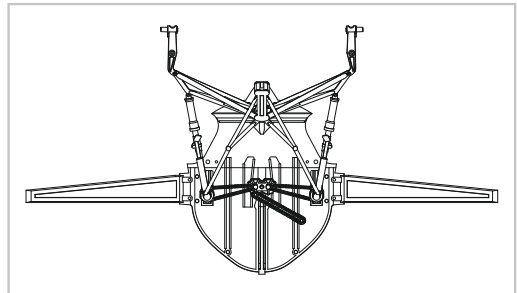
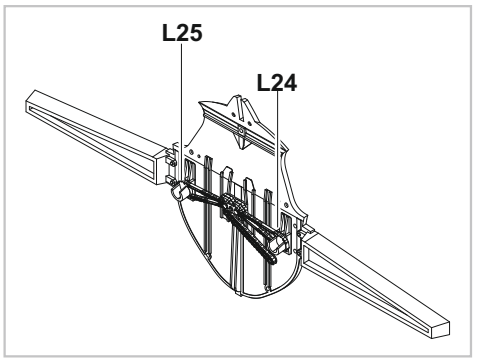
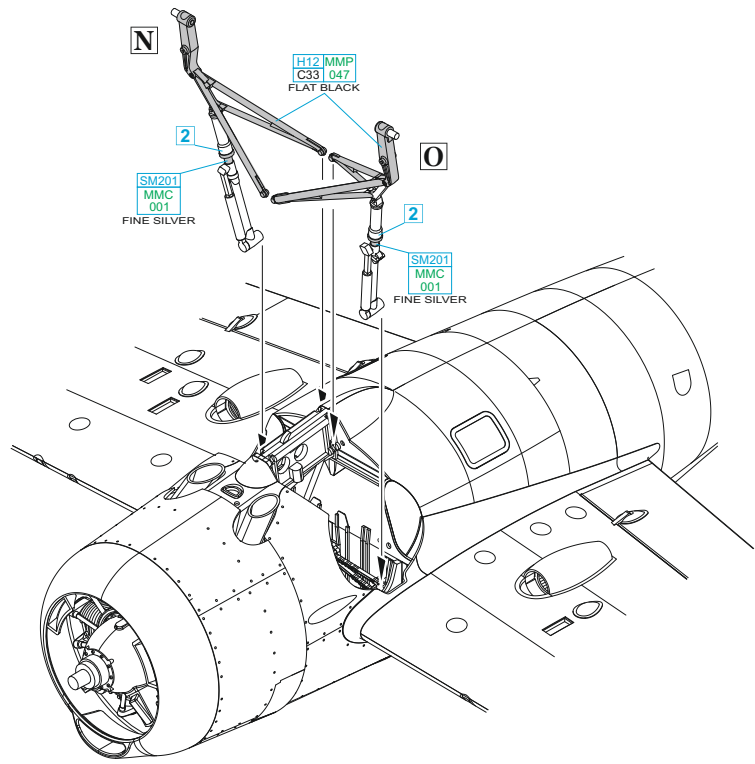
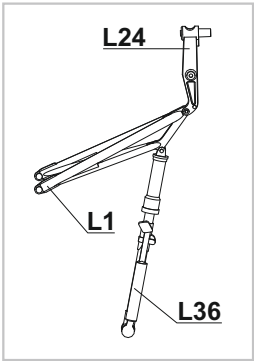
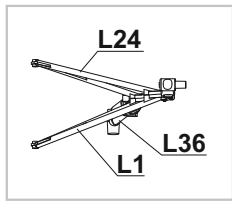
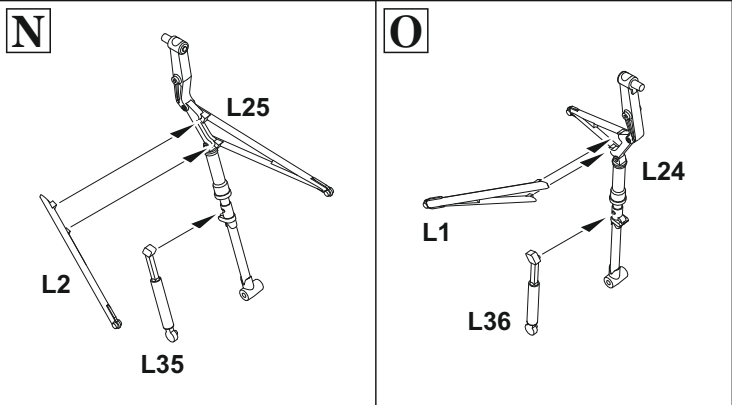

P

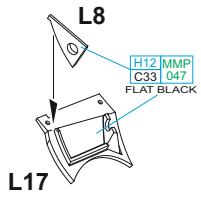

Q

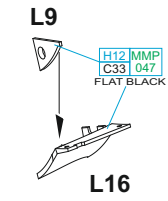

decal 113



M2 - MARKINGS A, C, D
M3 - MARKINGS B, E

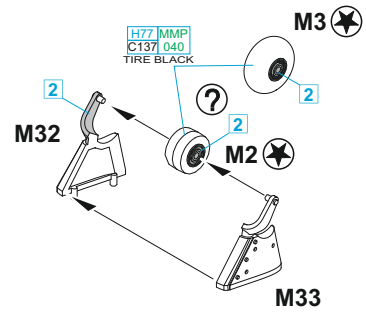

R 2 pcs.

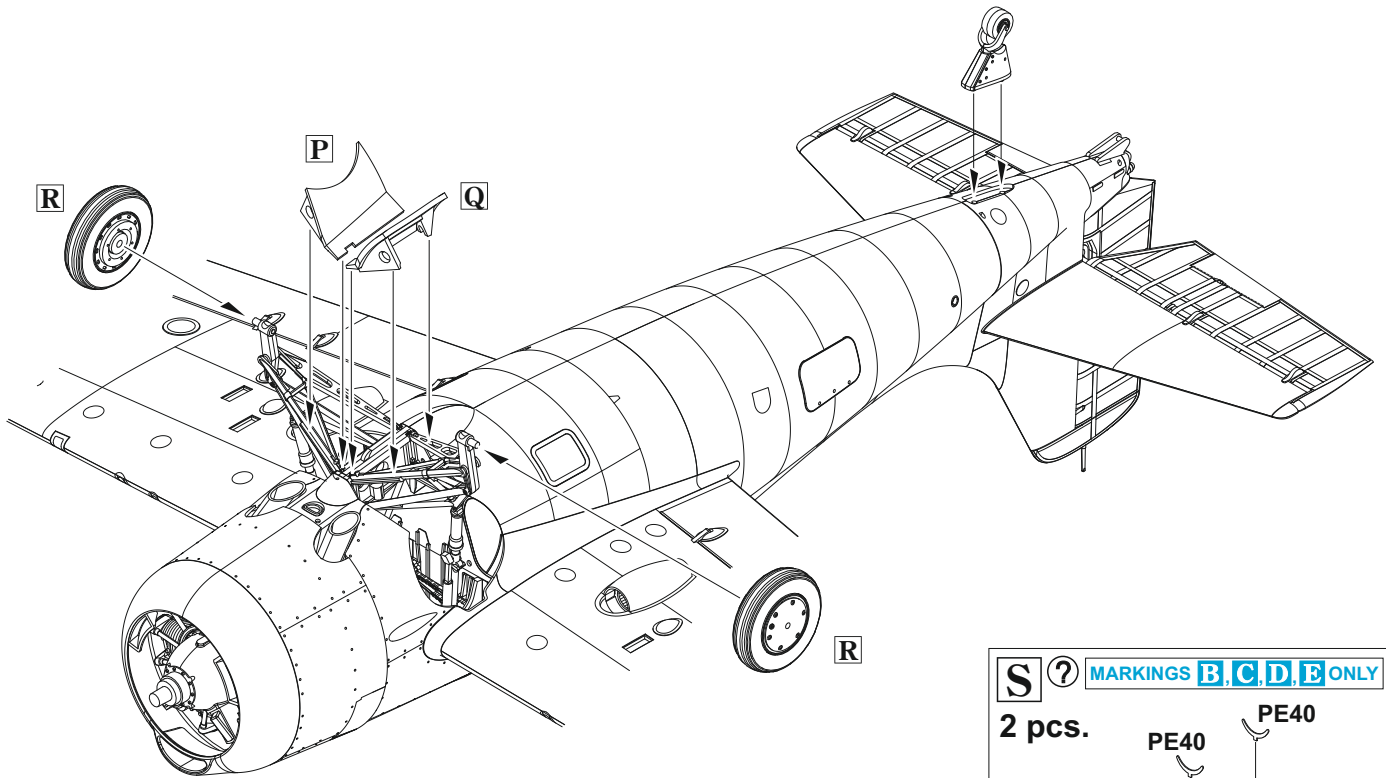
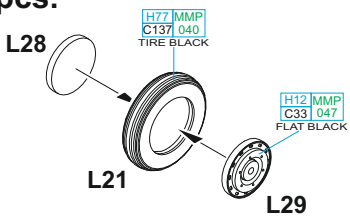

S ? MARKINGS B, C, D, E ONLY

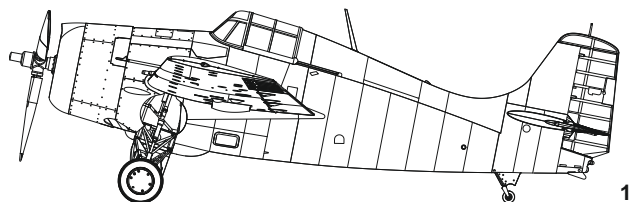
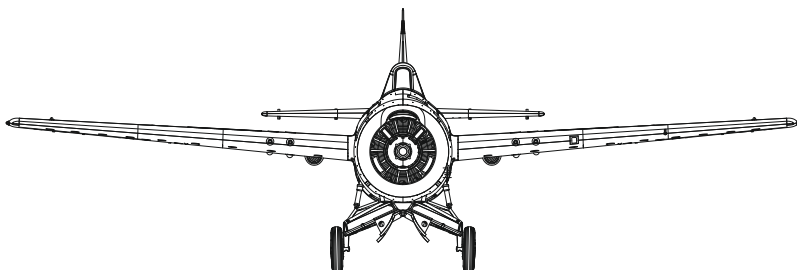
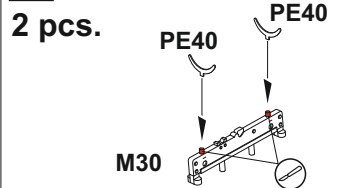

1 = 90% + 10%
 H58 MMP C351 059 INT. GREEN
 H12 MMP C33 047 FLAT BLACK

F4F-4

MARKINGS F, G, H, I, J

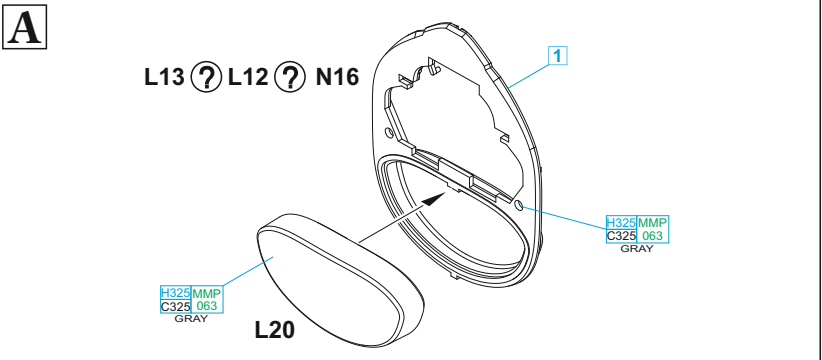
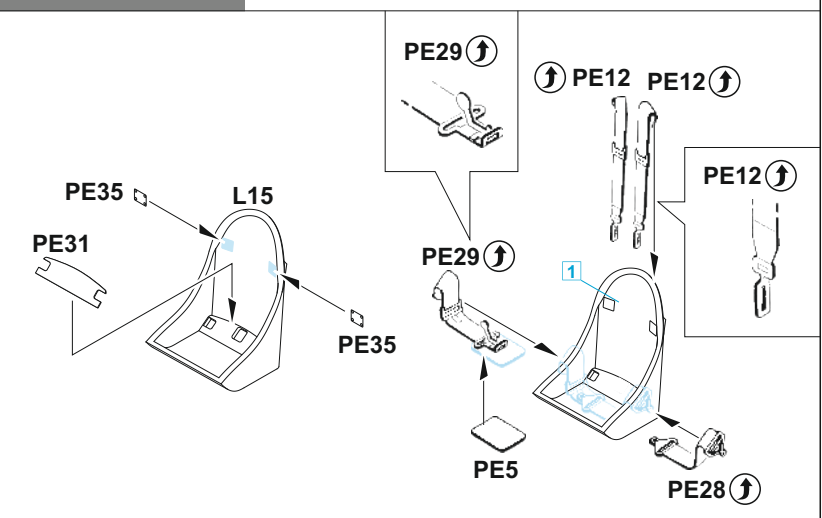
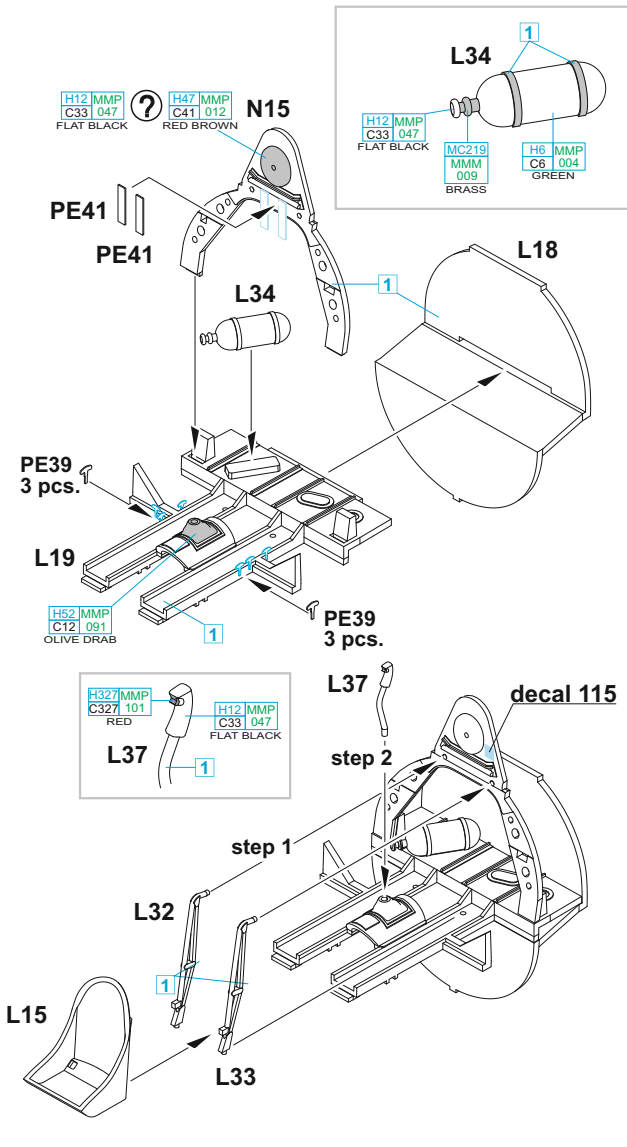

OPTIONAL:
 decals K11, K12, K13

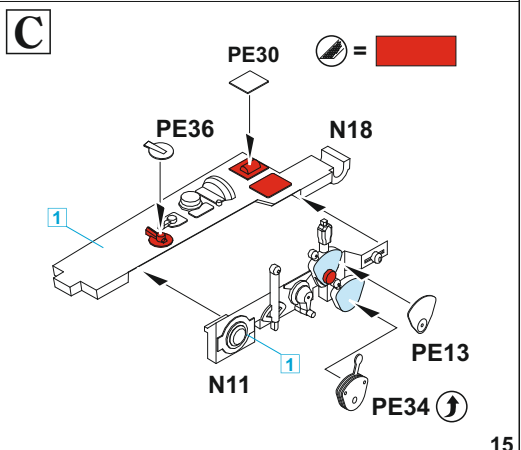
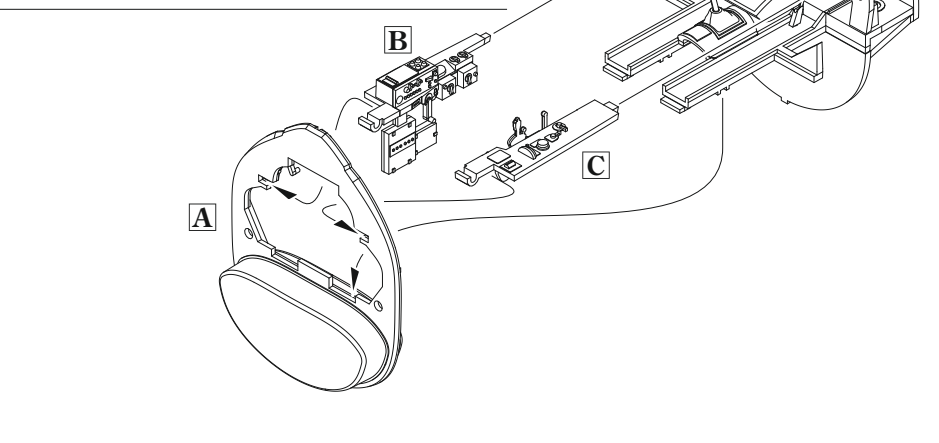
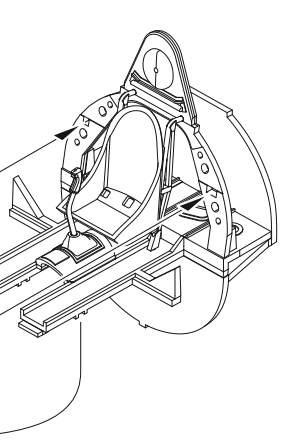
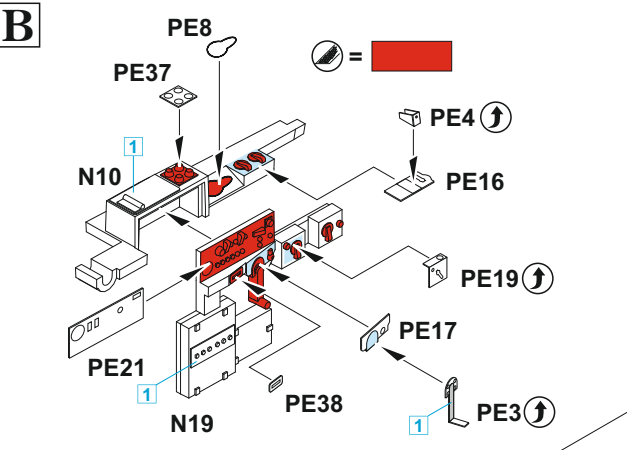
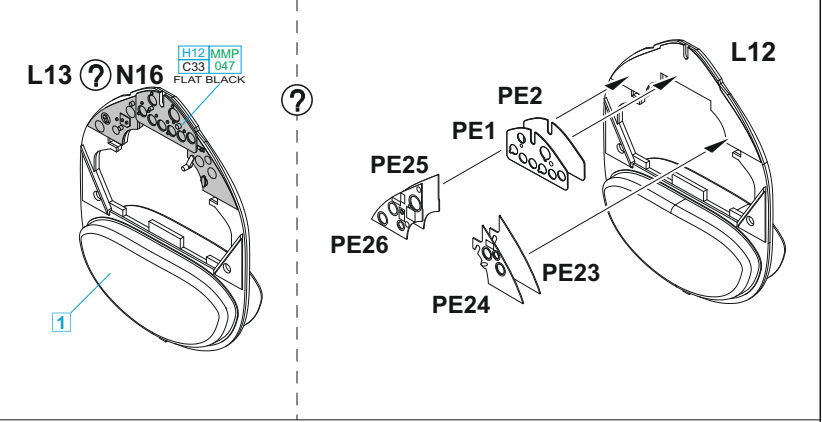

LATE VARIANTS

D

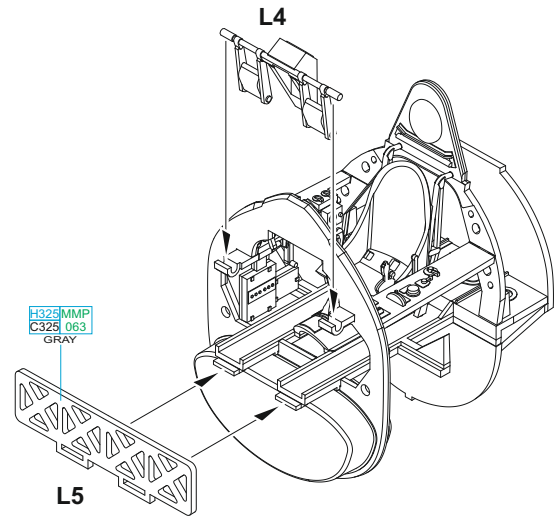
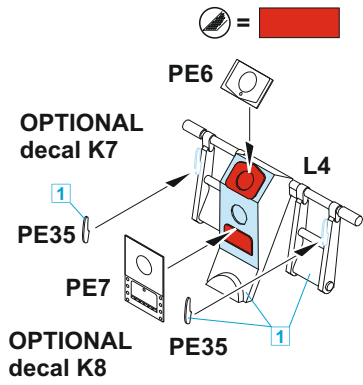

E

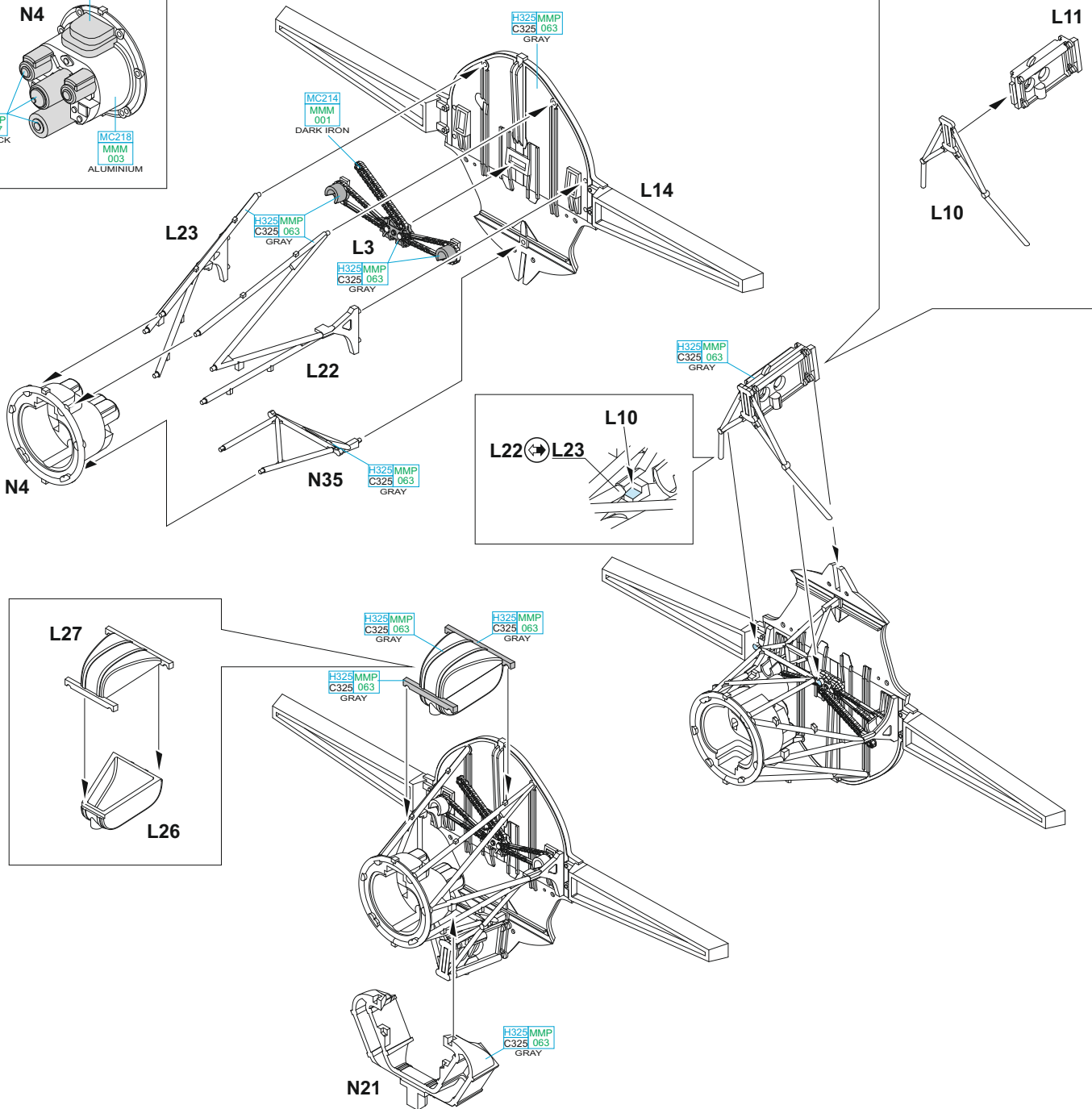
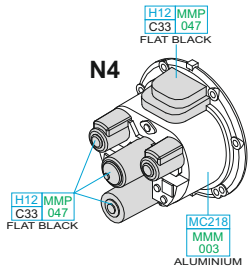

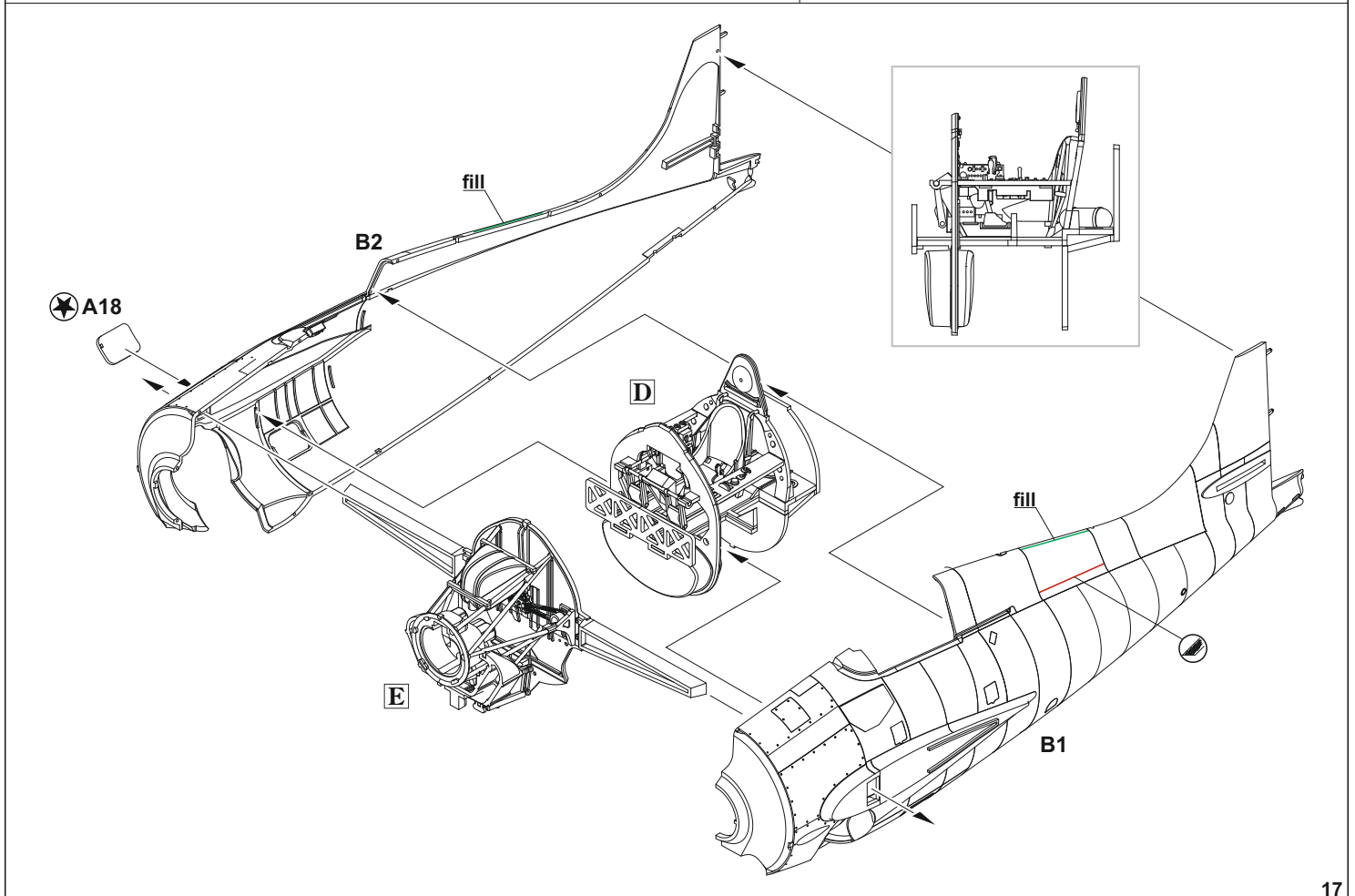
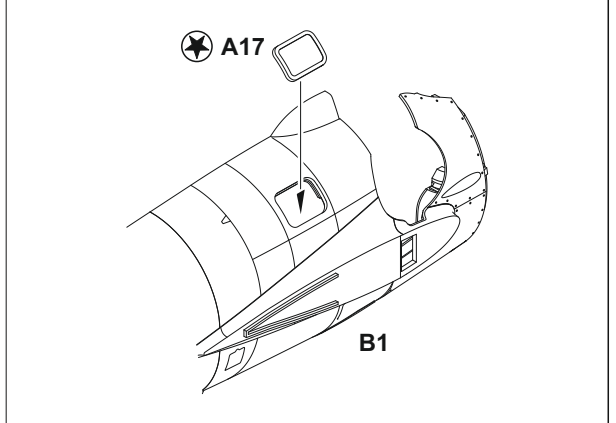
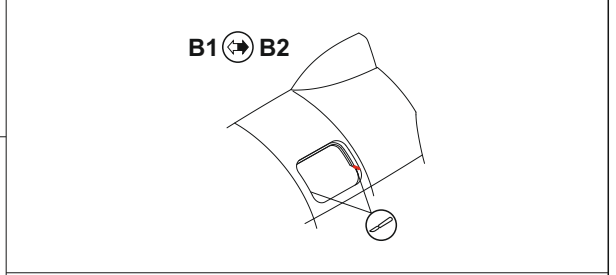
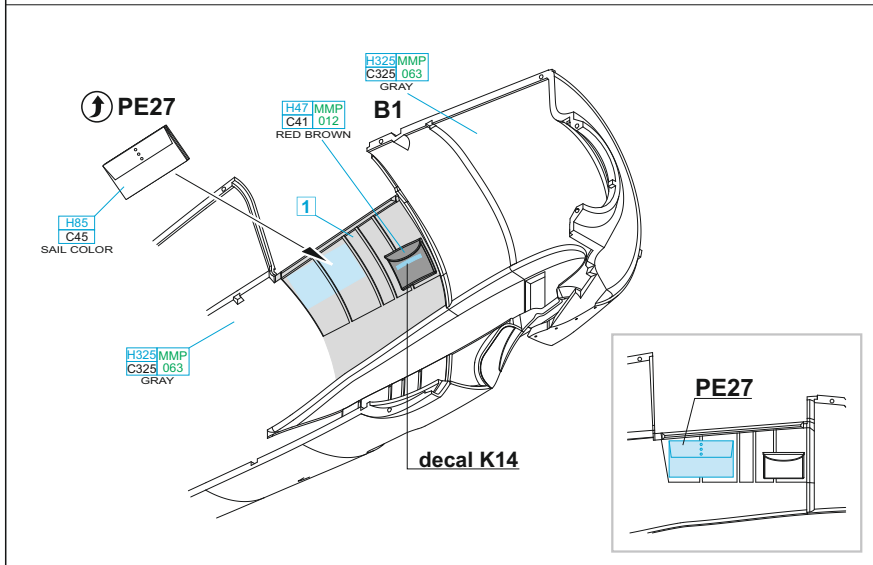
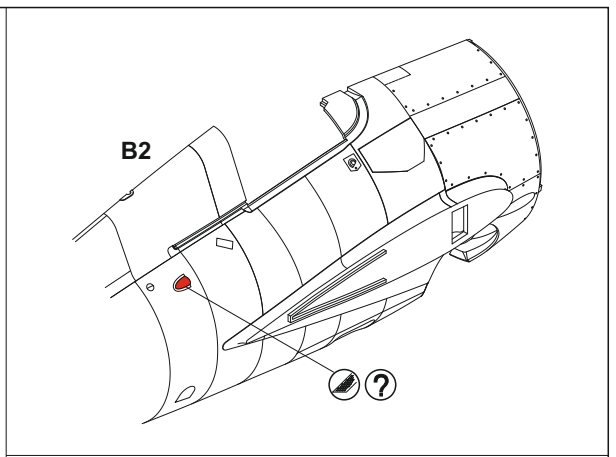
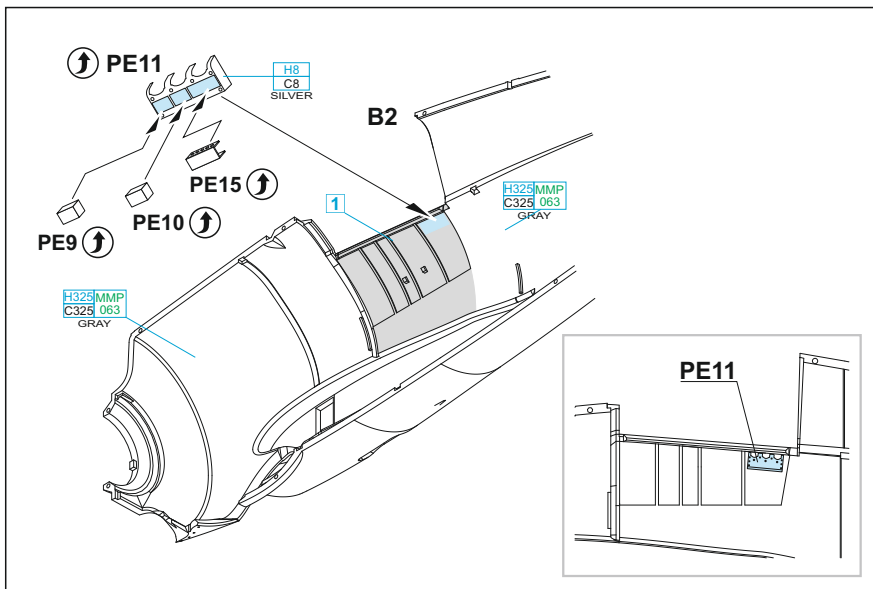

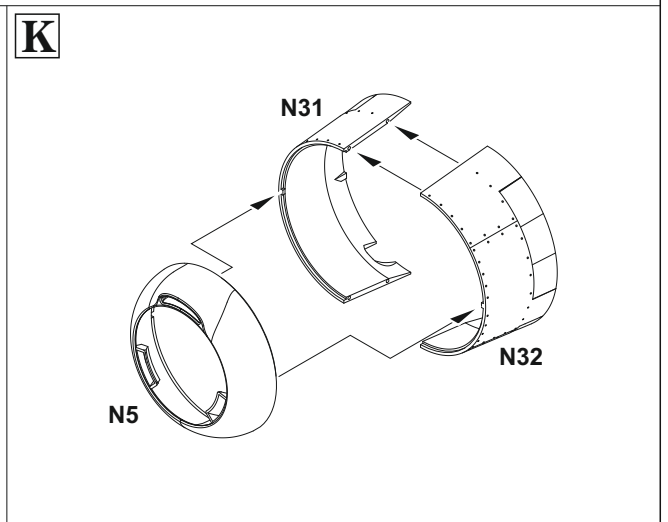
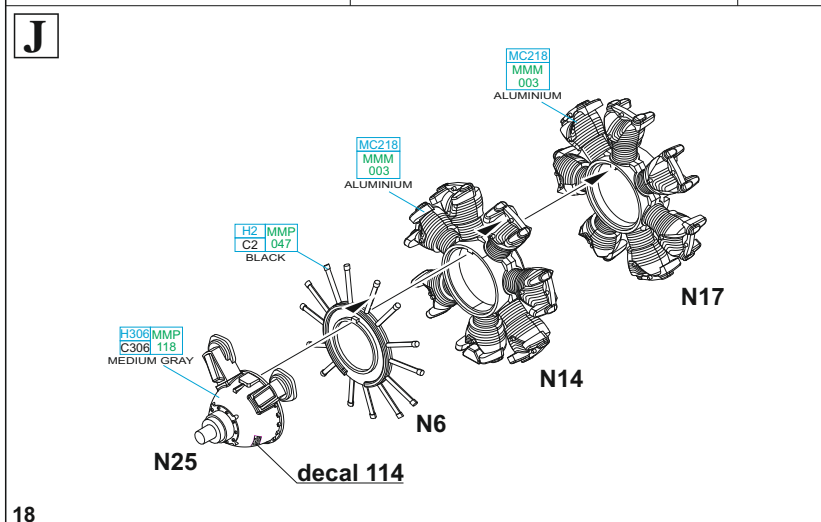
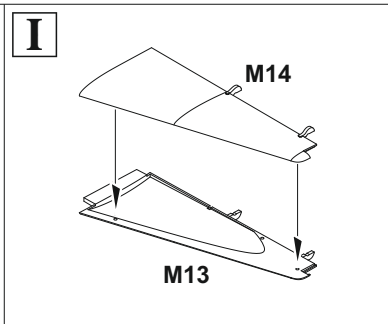
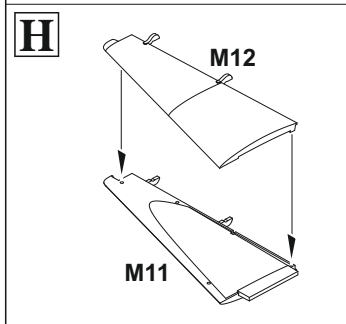
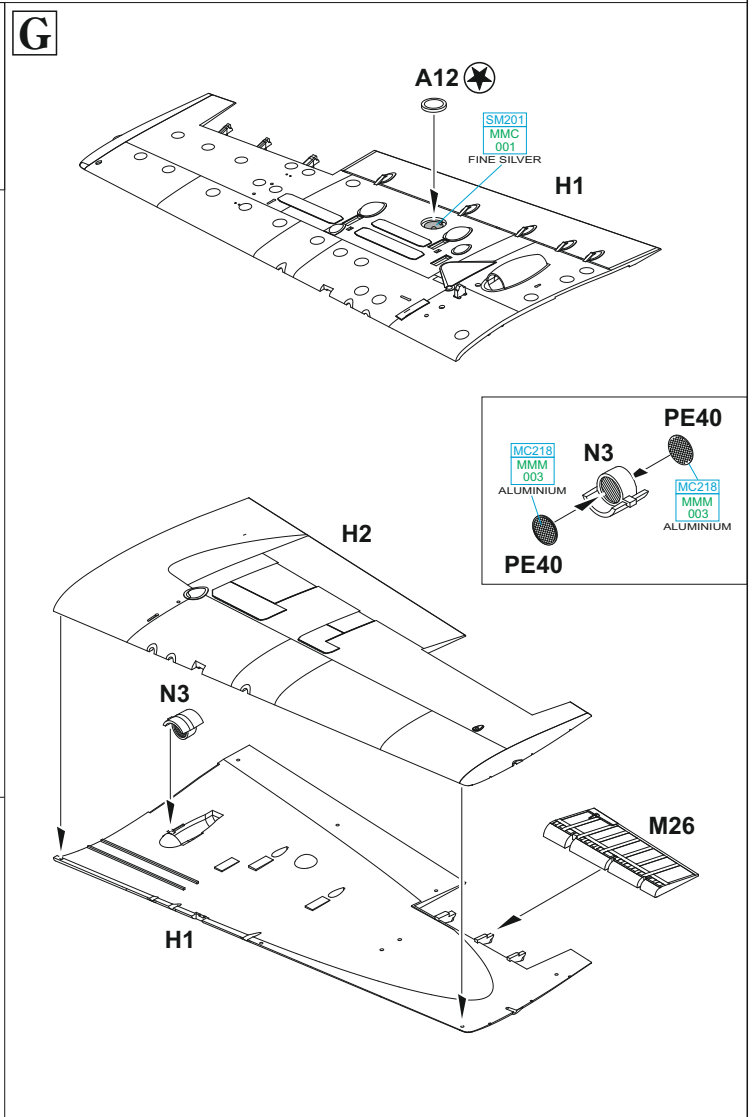
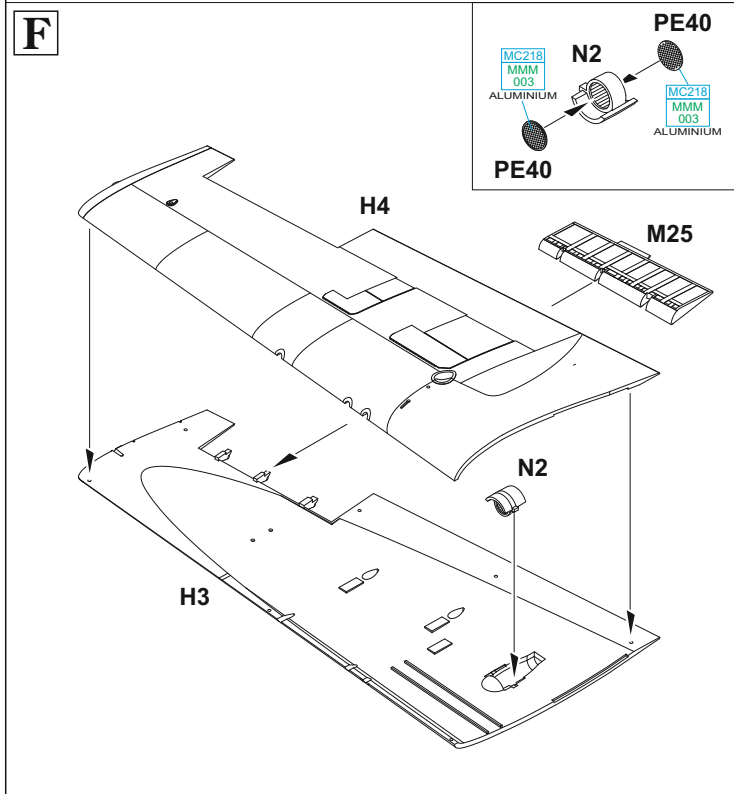
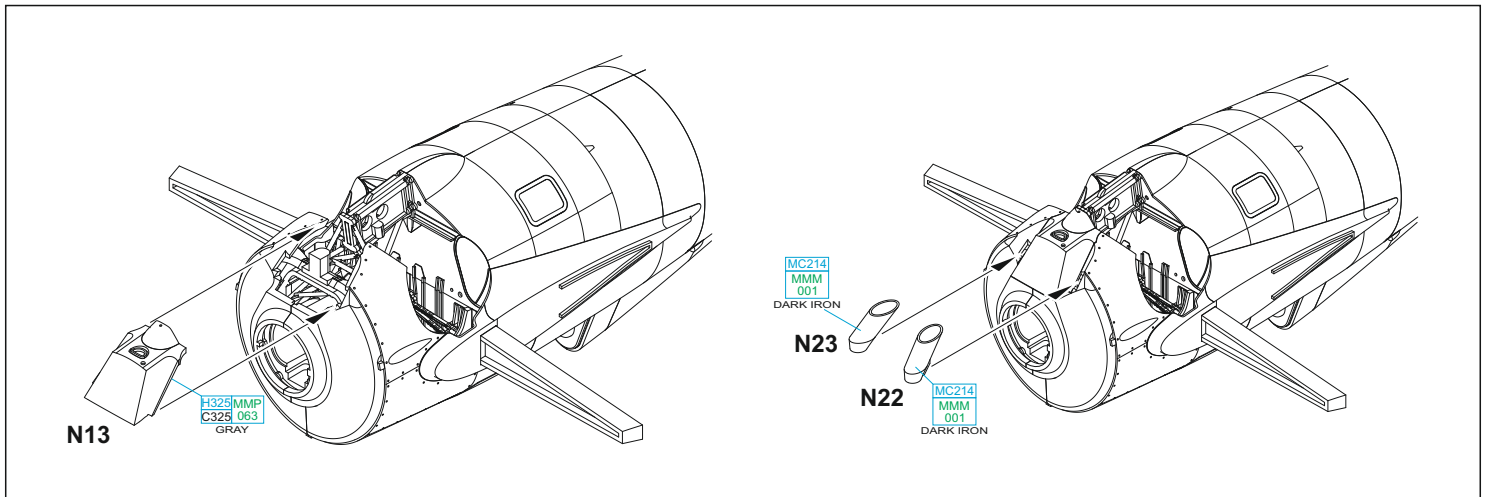

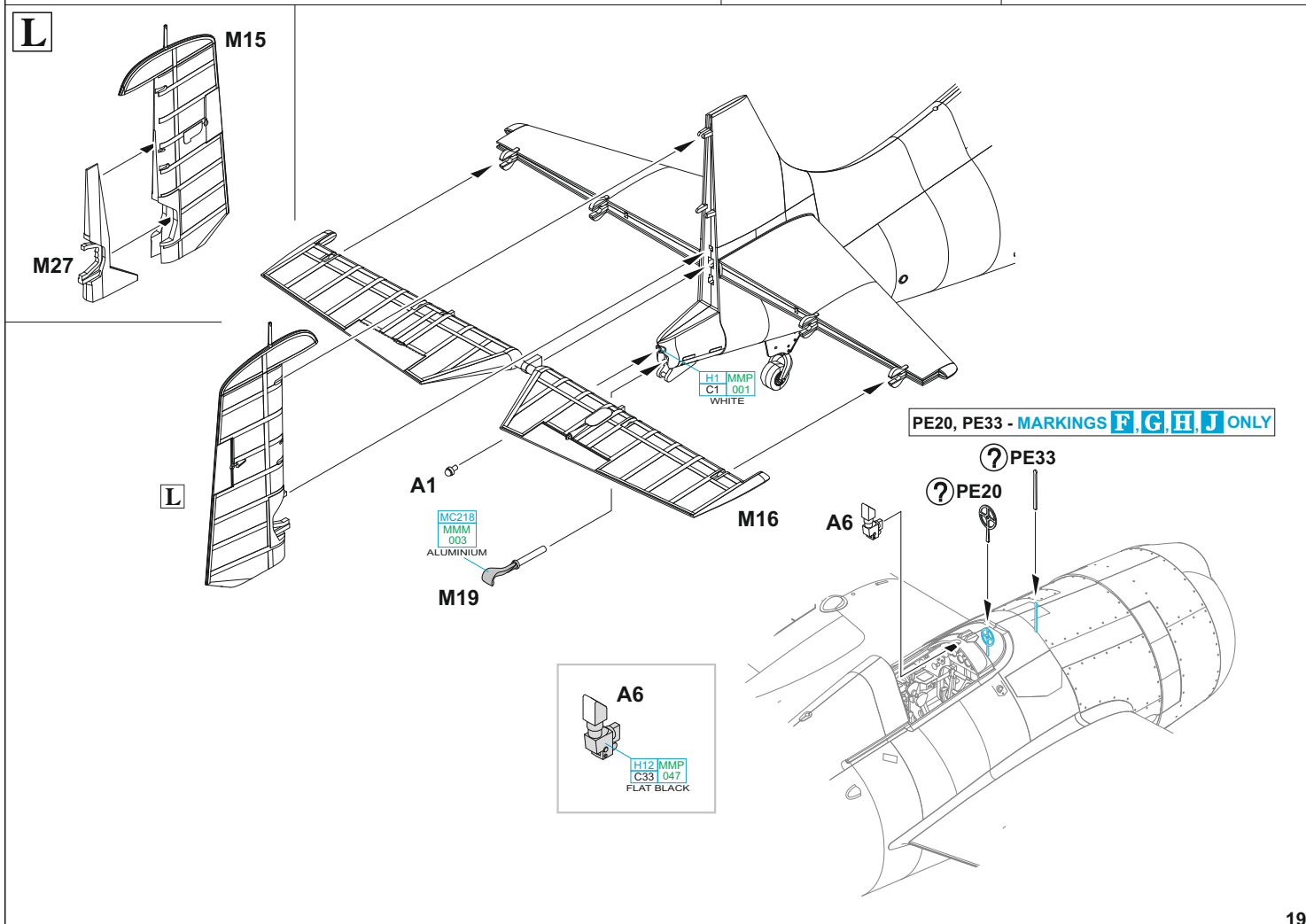
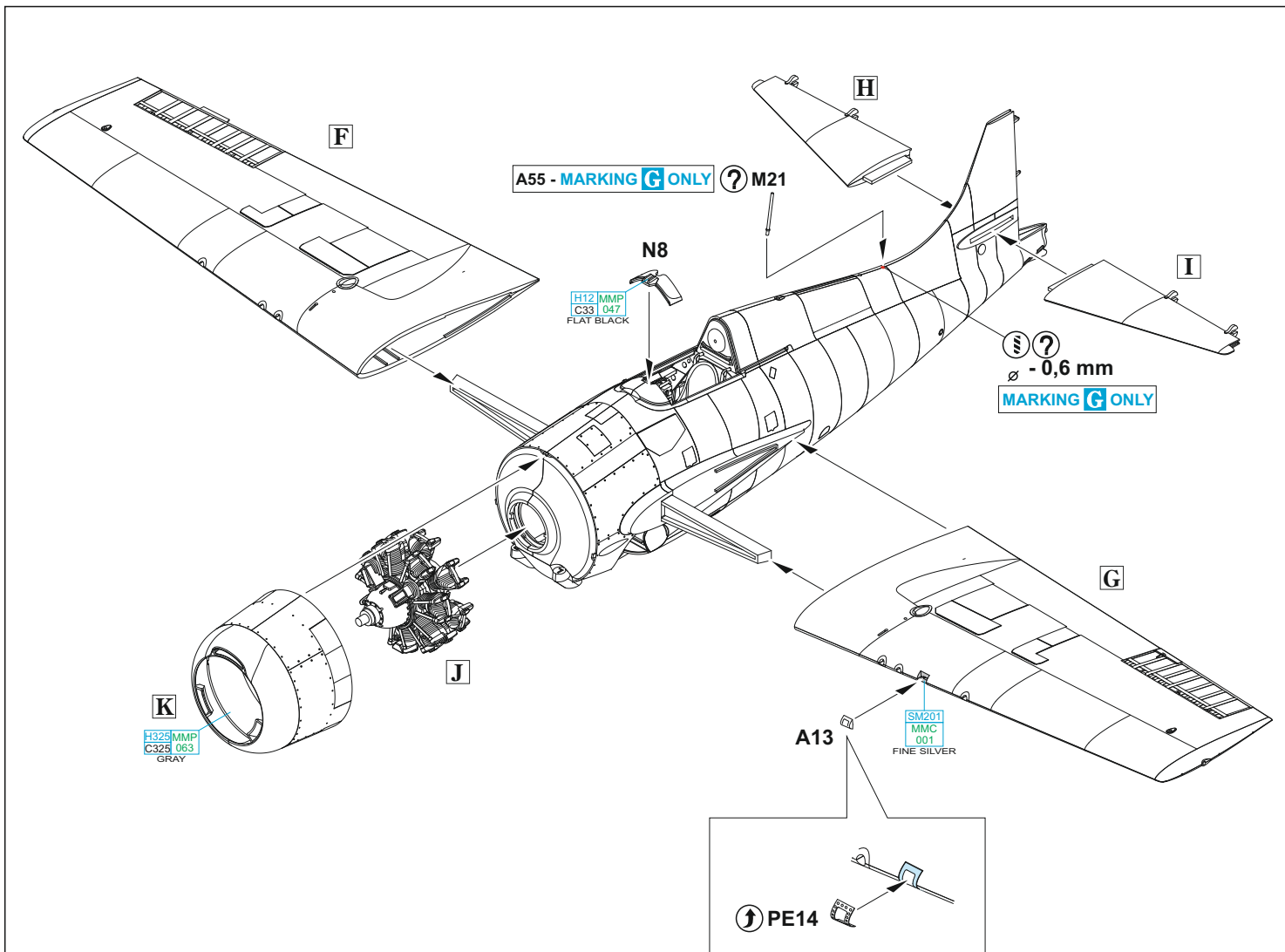

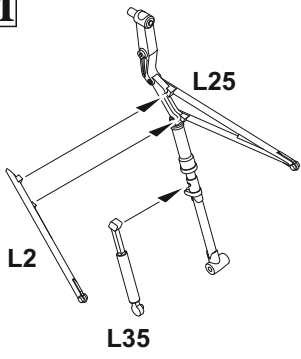
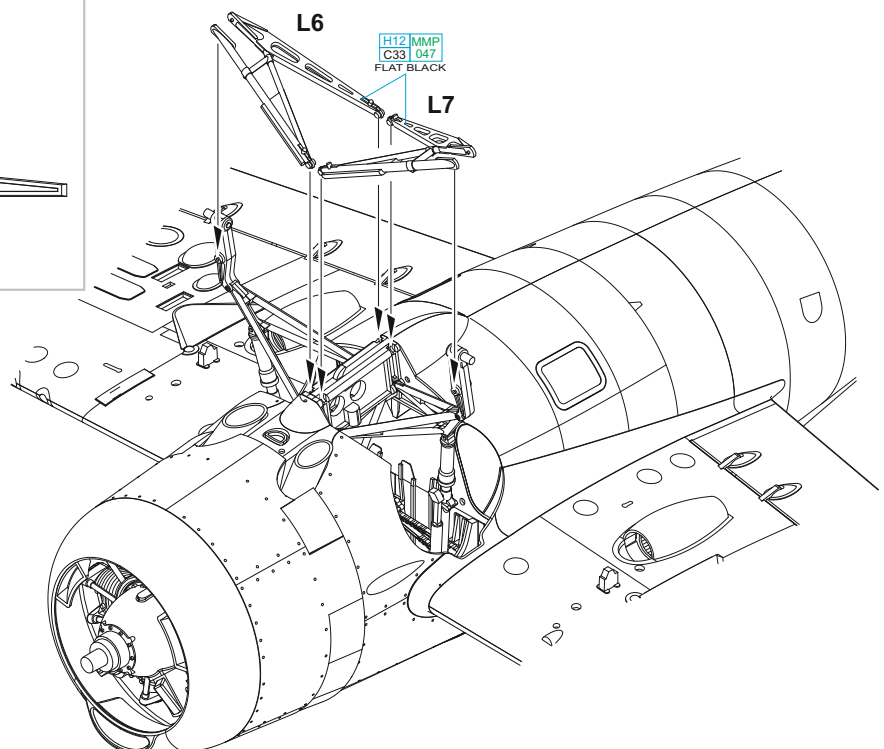
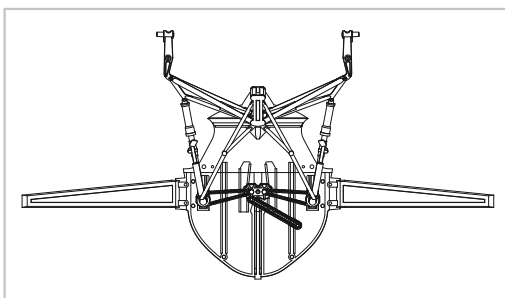
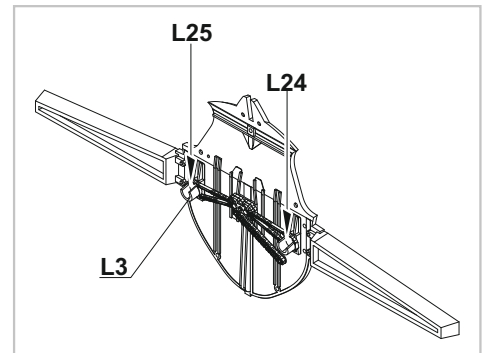
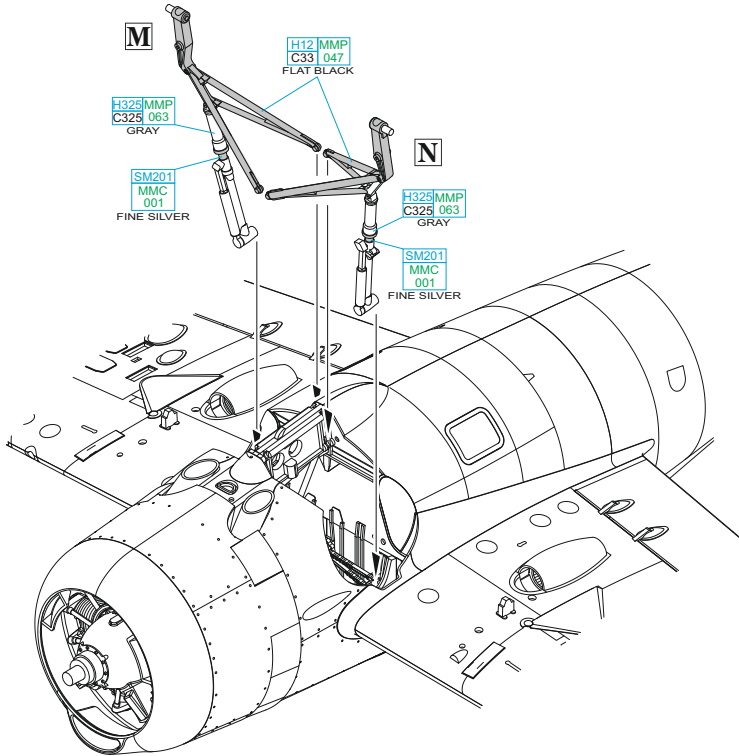
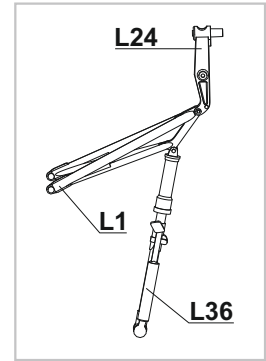
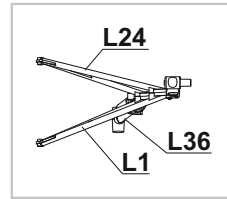
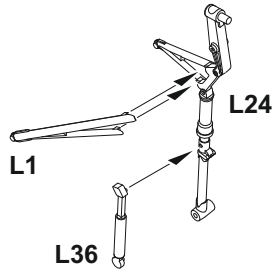
M**N**

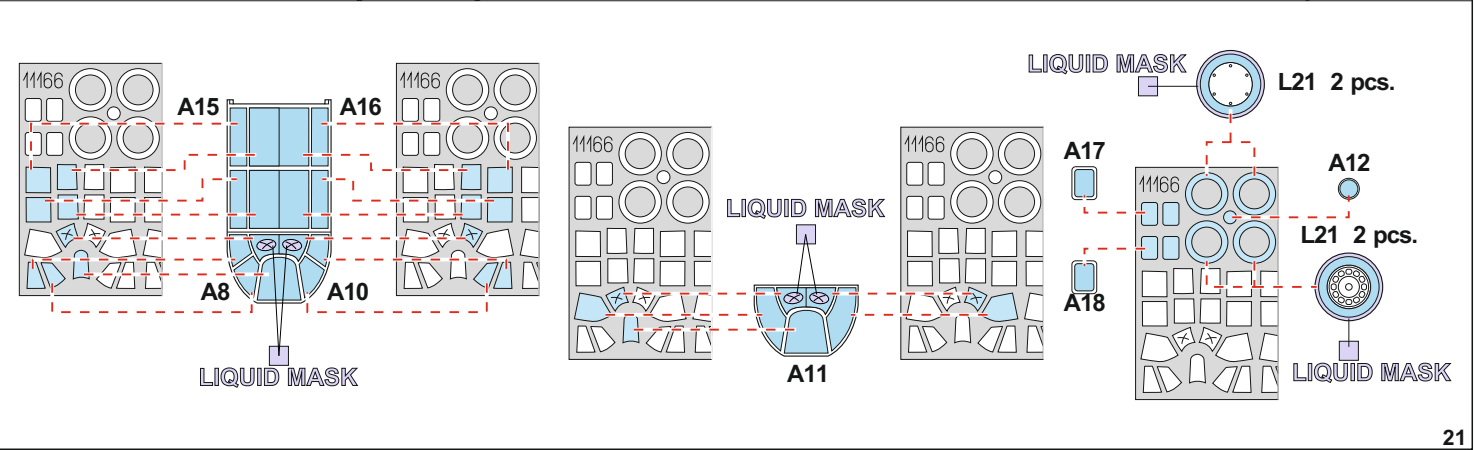
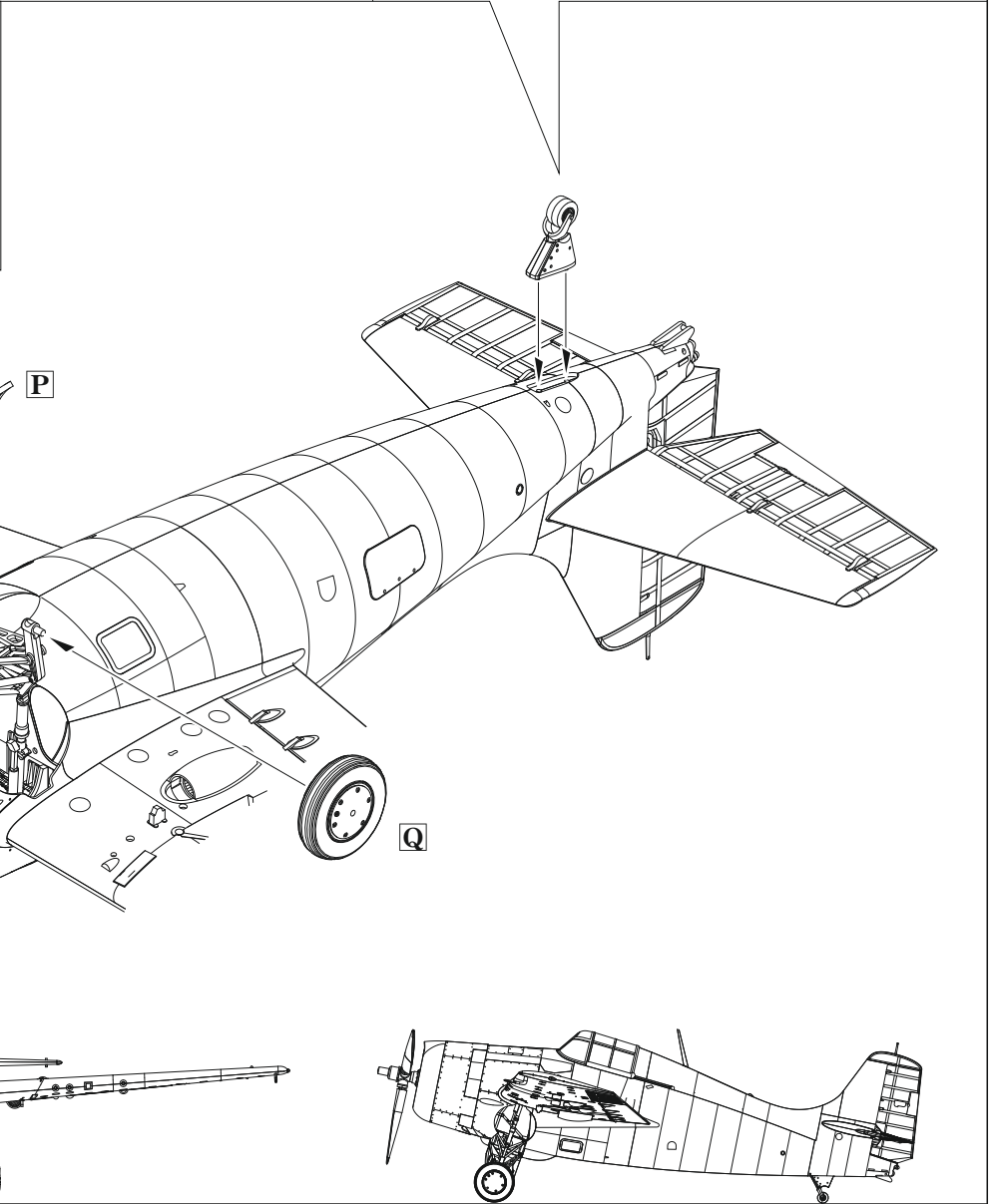
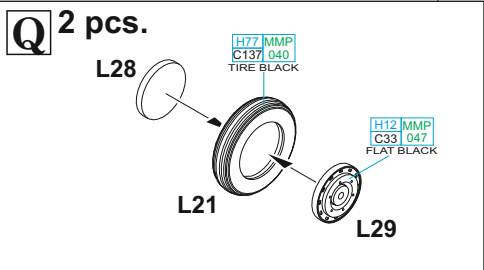
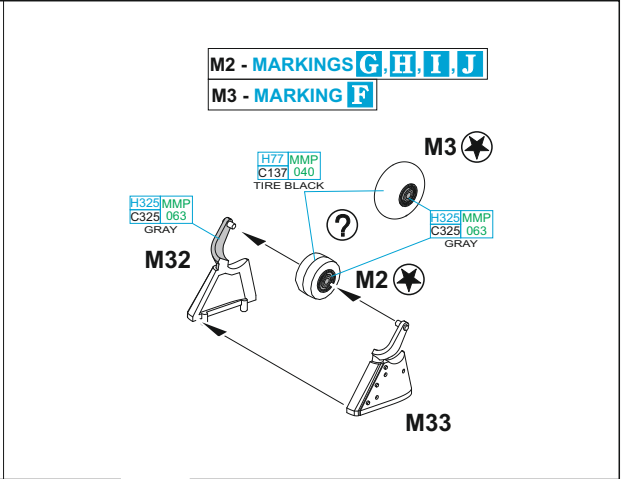
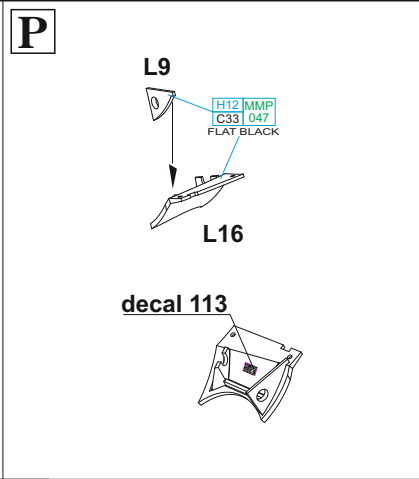
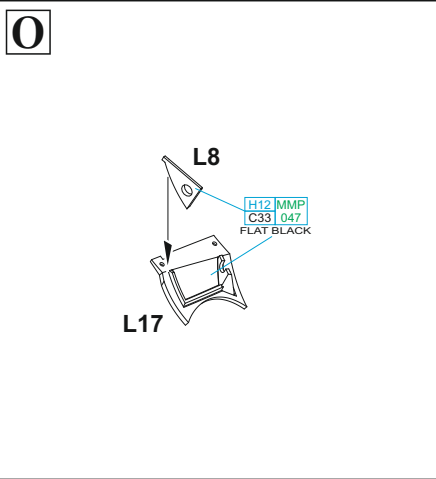

A F4F-3, BuNo. 1865, VF-72, USS Wasp (CV-7), December 1940

The first production block of Wildcats, 49 aircraft in total, were supplied in the pre-war color scheme i.e., the fuselage and wings' lower surfaces were sprayed in aluminium dope and the wing upper surfaces were painted yellow. The national insignia were in all four positions, on the fuselage they were painted either on the nose or on the engine cowling. The color of the tail surfaces indicated the aircraft carrier. In this case it was USS Wasp (CV-7). The wing stripes, including the front of the cowlings identified the aircraft allocation to the unit section. Red was the color of the first section and if only the upper front of the cowlings was painted in this color it marked the second aircraft in this section. This Wildcat was captured on the film during the landing on the USS Wasp deck. The pilot managed to catch the landing rope with his hook however the rope broke and the aircraft was stopped by the safety net. In the film we can clearly see that this Wildcat carries the unit marking on the port wing only, starboard wing is missing both the red diagonal stripe and the number 2. The starboard wing could have been replaced and the marking added later.

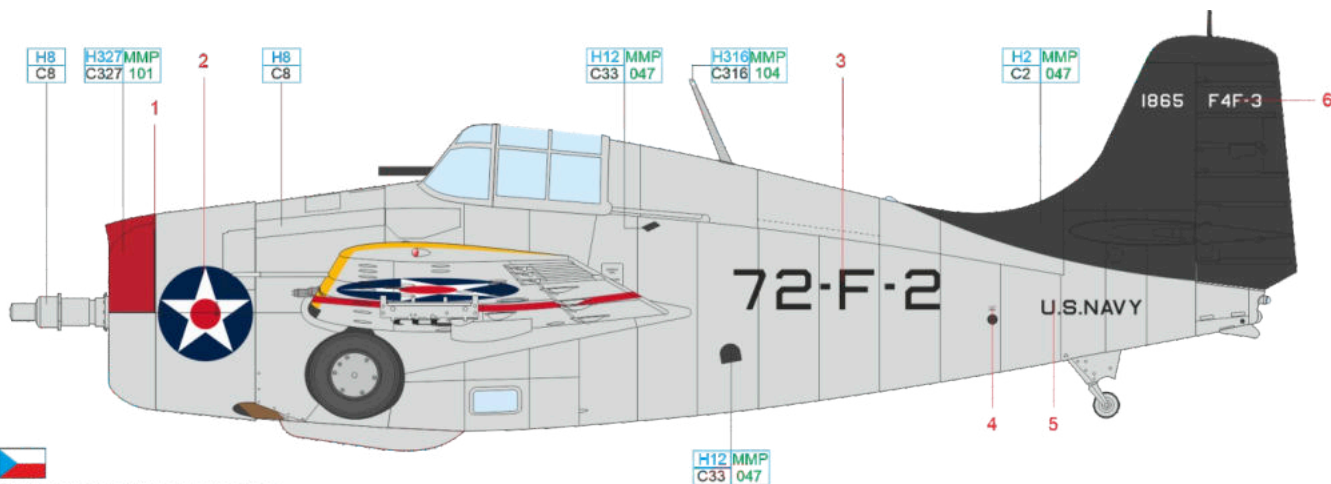

ČESKOU VERZI TEXTU NALEZNETE NA www.eduard.com POD KATALOGOVÝM ČÍSLEM 11166

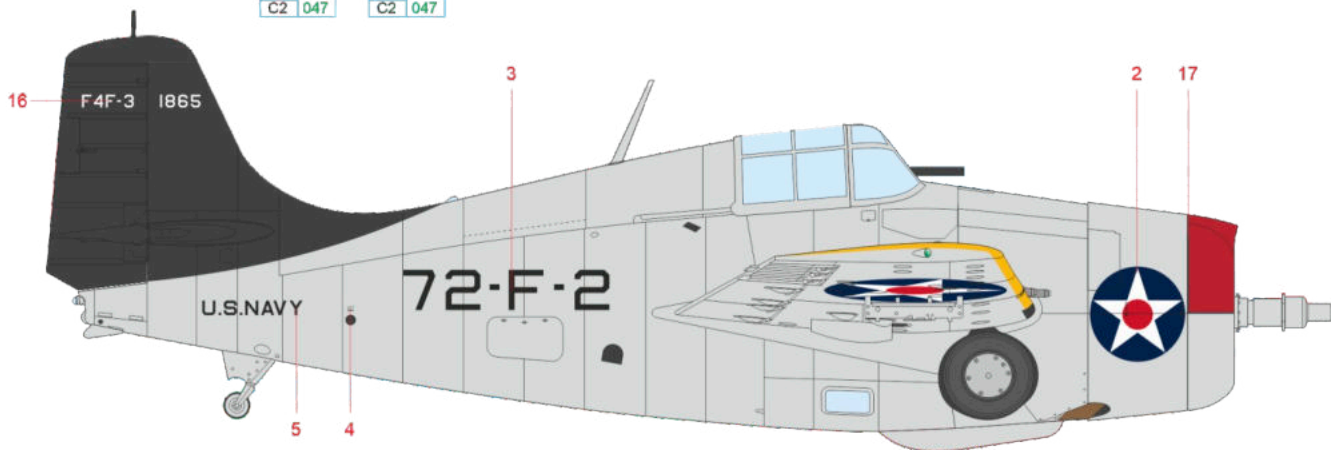
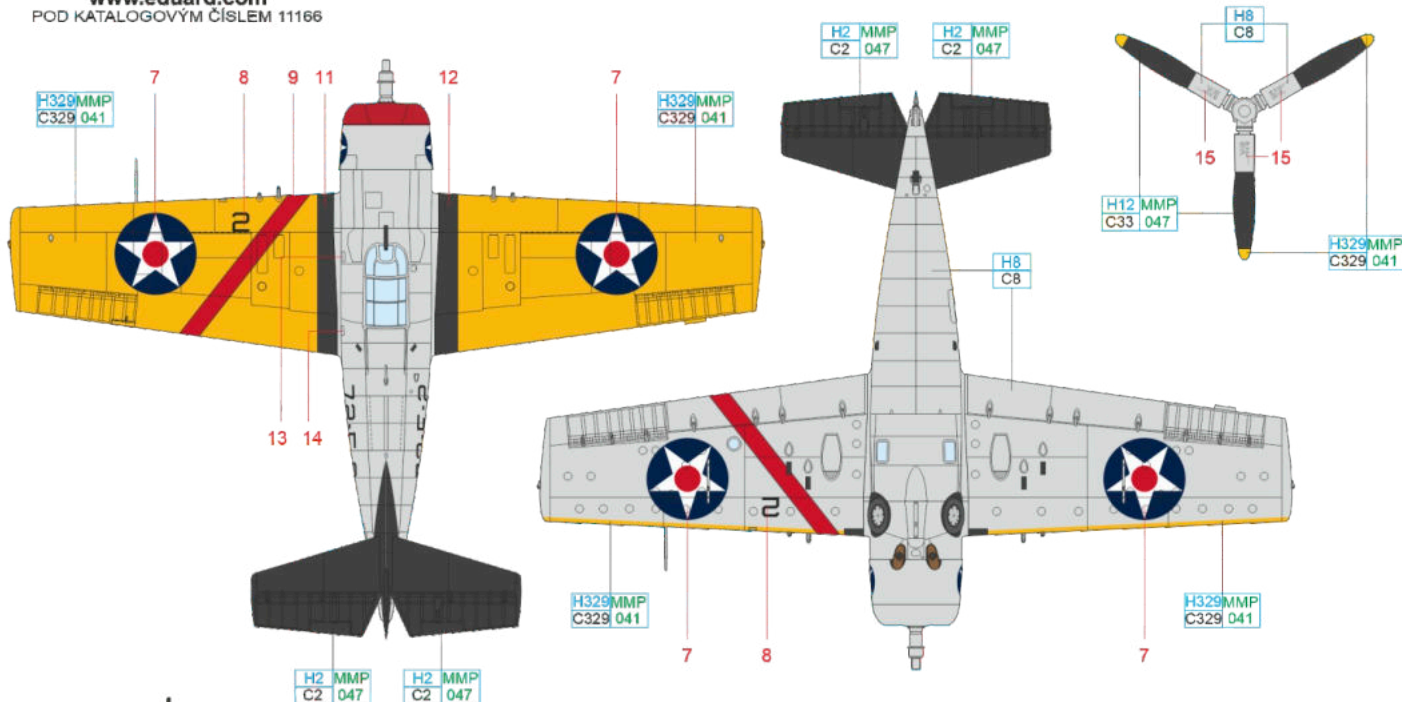

- SILVER H8
C8
- WHITE H316 MMP
C316 104
- YELLOW H329 MMP
C329 041
- RED H327 MMP
C327 101
- BLACK H2 MMP
C2 047
- BLACK H12 MMP
C33 047

B F4F-3, BuNo. 4022, Capt. Herbert Casper Freuler, VMF-211, Wake Island, December 1941

The Japanese made their first attempt at capturing the Wake Atoll on December 11, 1941, but their attack was repelled. They did not give up, after receiving the reinforcements the landing on the island was scheduled for December 23. The landing was preceded by the air attacks from Sōryū and Hiryū carriers executed on December 22, 1941, again opposed by Wildcats from VMF-211. There were the last two remaining VMF-211 Wildcats as the unit was decimated during the previous landing attempt. One of their pilots was Captain Herbert Casper Freuler who on this day shot down two B5N Kate bombers. Shortly after a Zero shot him down and he was wounded. After the Japanese captured the island Captain Freuler was taken POW and spent the following 3.5 years in captivity. After the end of WWII, he continued his service with USMC and retired in 1955 as Brigadier General.

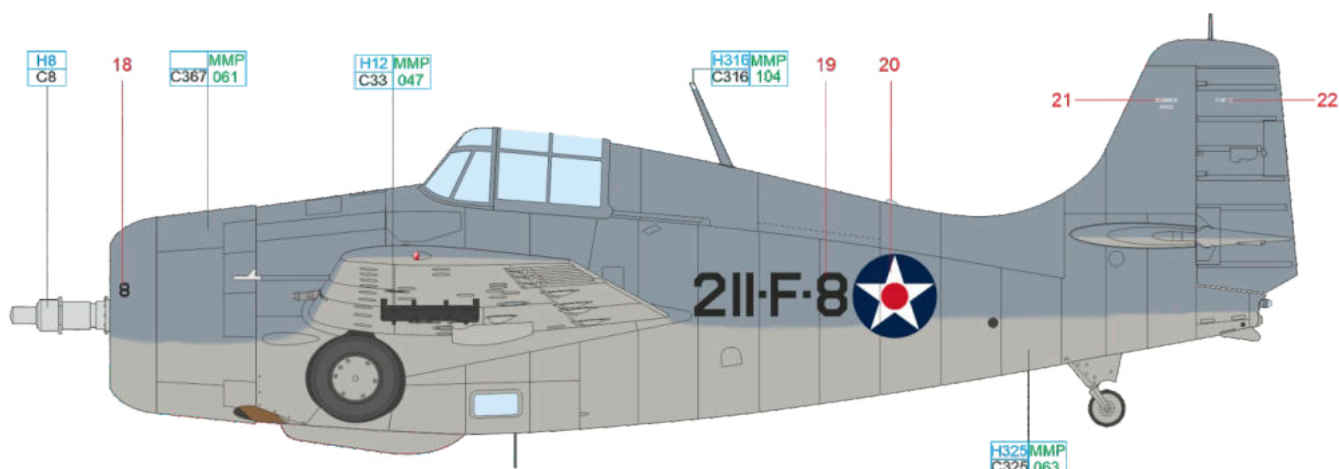

ČESKOU VERZI TEXTU NALEZNETE NA www.eduard.com POD KATALOGOVÝM ČÍSLEM 11166

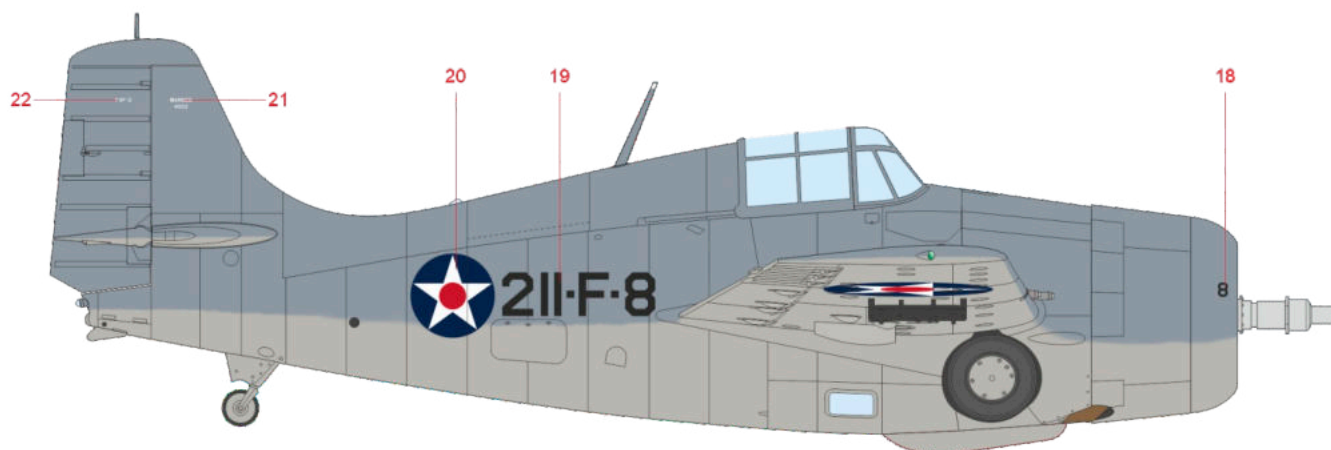
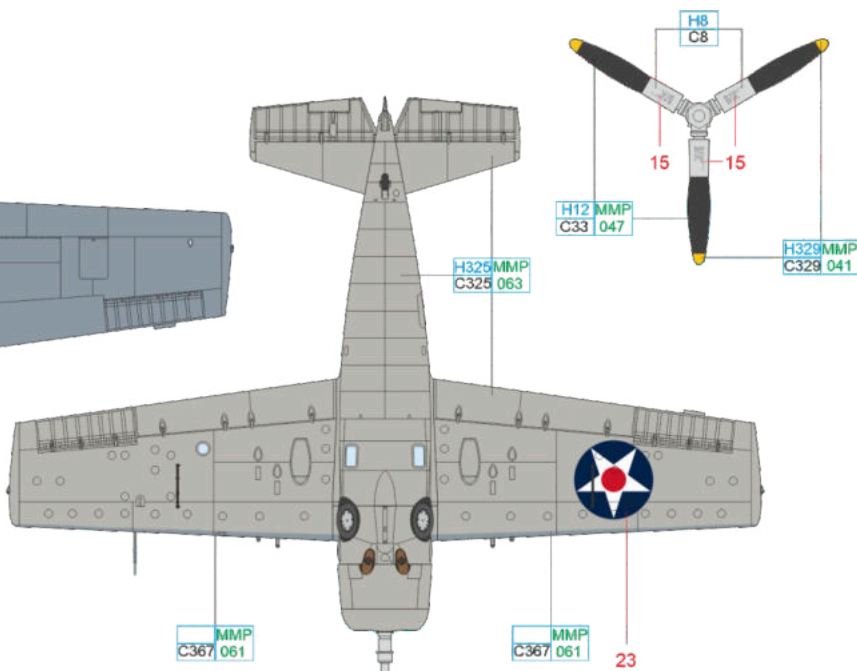
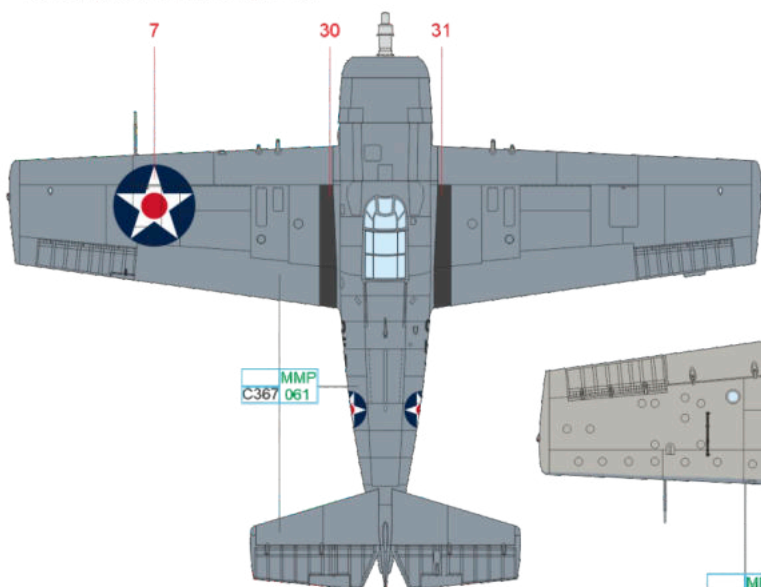

SILVER H8 C8 GRAY H325 MMP C325 063 WHITE H316 MMP C316 104 BLUE GRAY MMP C367 061 BLACK H12 MMP C33 047 YELLOW H329 MMP C329 041

eduard

C F4F-3A, BuNo. 3920, Lt. James Seton Gray, VF-6, USS Enterprise (CV-6), February 1942

Milwaukee, Wisconsin native, James Seton Gray loved the flying since the childhood. In 1930, at the age of sixteen years he became the youngest pilot license holder. After he graduated from the United States Naval Academy in 1936, he served on the ships. In 1938 he started his pilot training and after its completion he was assigned to VF-6 on board of USS Enterprise (CV-6). After the USA entered the war, he took part in the first Navy raid against the Japanese on Taroa island in Marshall Islands. During the raid he shot down two A5M Claude fighters. During the Battle of Midway he commanded the whole VF-6 escorting VT-6 Devastators on their attacks against the Japanese carriers. During the afternoon CAP on that day he shot down E13A Jake floatplane. Gray added further kills to his score while commanding the night fighters aboard USS Enterprise in 1944 and became a fighter ace. Lt. Gray's Wildcat in which he fought over Marshall and Gilbert archipelagos was camouflaged in Light Gray and Blue Gray. The rudder sports nine red and white stripes. The national markings on the fuselage and wings were already supposed to be enlarged however the aircraft photograph shows that the large insignia were painted on the fuselage and starboard wing only. The port wing retained the original size insignia.

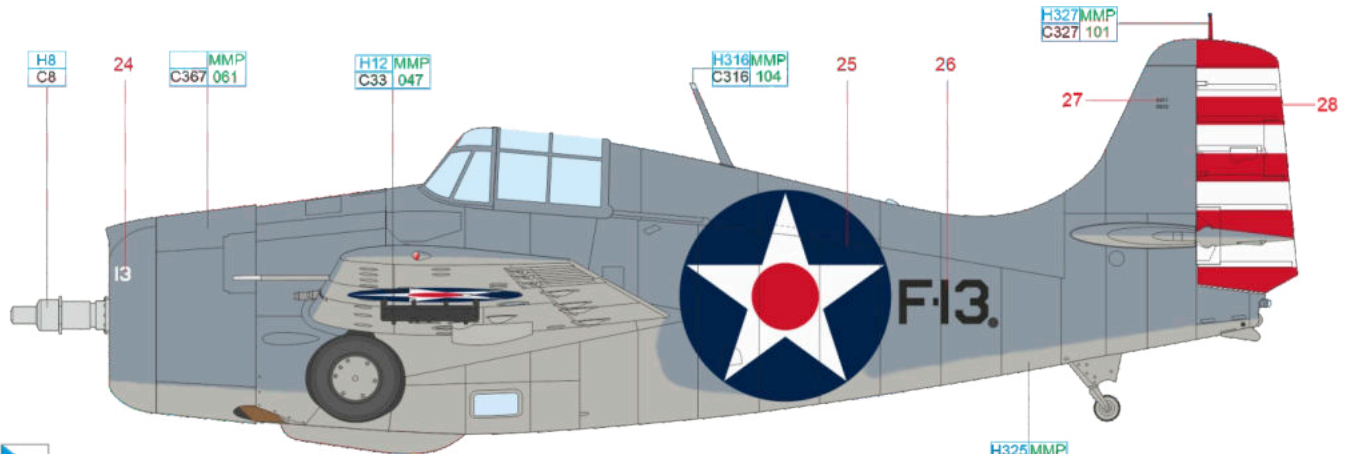

ČESKOU VERZI TEXTU NALEZNETE NA
www.eduard.com
 POD KATALOGOVÝM ČÍSLEM 11166

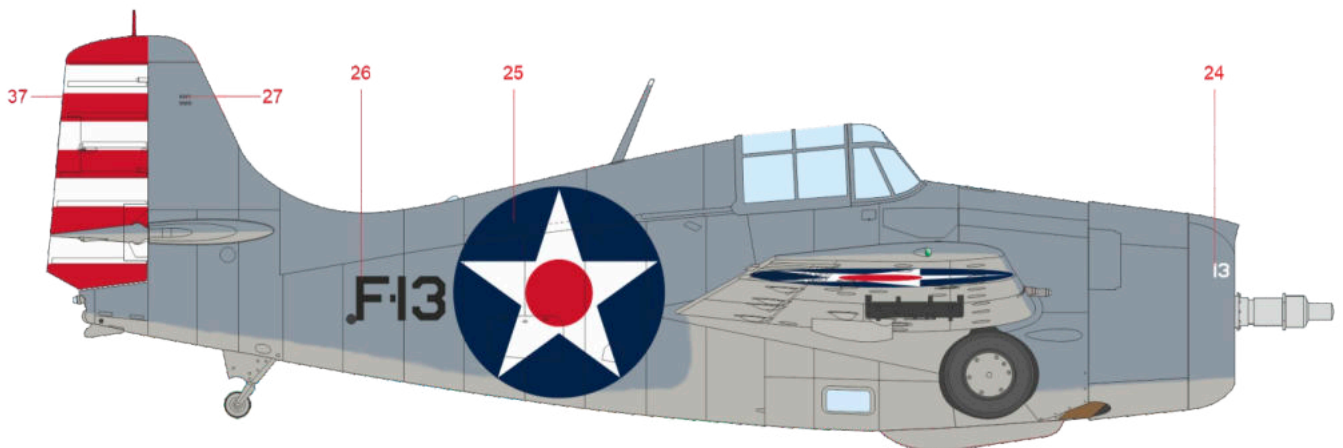
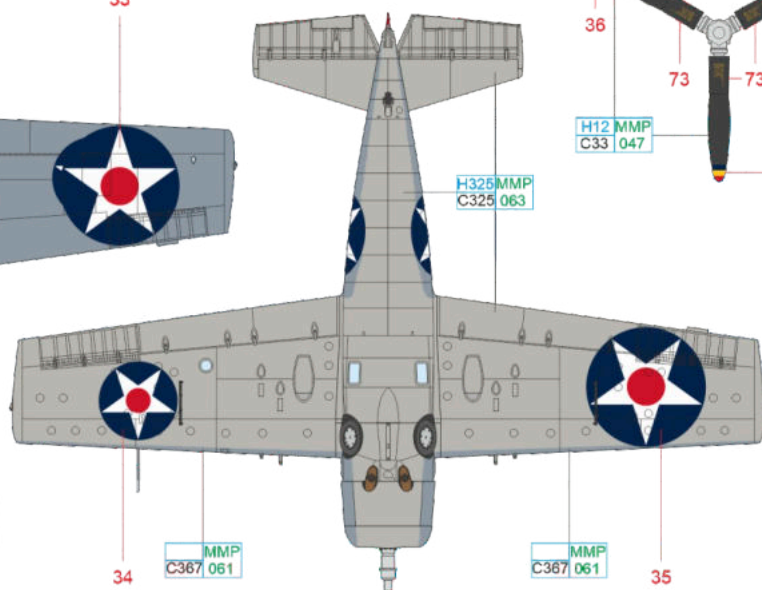
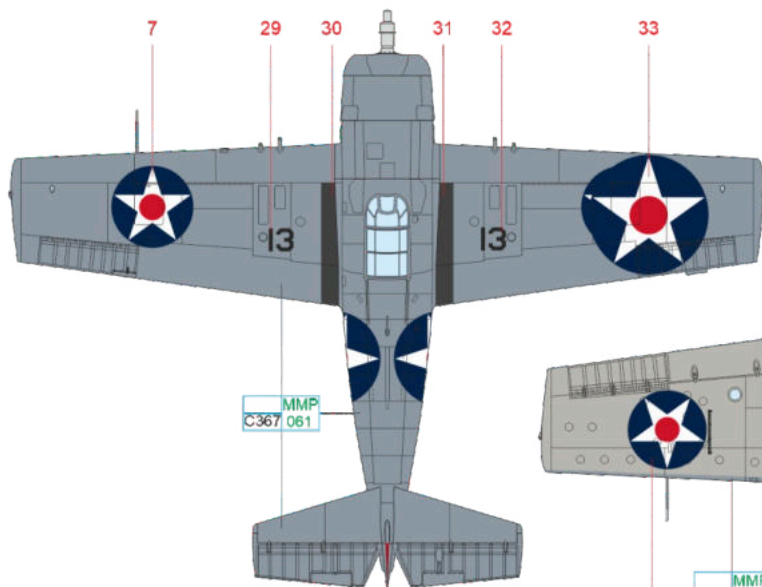

SILVER	H8 C8	GRAY	H325 MMP C325 063	WHITE	H316 MMP C316 104	BLUE GRAY	MMP C367 061	RED	H327 MMP C327 101	BLACK	H12 MMP C33 047
--------	----------	------	----------------------	-------	----------------------	-----------	-----------------	-----	----------------------	-------	--------------------

D F4F-3, Lt. Frank Bernard Quady, VF-6, USS Enterprise (CV-6), April 1942

The attack against Japan, scheduled for April 1942 was going to be conducted by B-25 medium bombers taking off of the aircraft carrier and was going to attack Japanese homeland islands. USS Hornet (CV-8) aircraft carrier became the "floating airport" for these bombers and was escorted by the formation gathered around USS Enterprise (CV-6) which was going to provide the air cover for the mission since the Hornet aircraft were not available until the bombers departure. One of the VF-6 pilots providing the fighter cover for the whole mission was Minneapolis native Lt. Frank Quady. He graduated from the Annapolis Academy and pinned his "wings" on in April 1941. He flew with VF-6 aboard USS Enterprise (CV-6) participating in Hornet escort during the Doolittle raid but also in all preceding missions flown by this unit during the first six month of the war. His last combat mission with VF-6 was Battle of Midway. Then the service with VF-11 followed and he increased his score by two D3A Val dive bombers shot down. Later he became member of the staff of the TF 58 commanding officer, Vice Admiral Mark A. Mitscher and was among the staff members killed during the attack of two kamikaze aircraft on USS Bunker Hill (CV-17) on May 11, 1945.

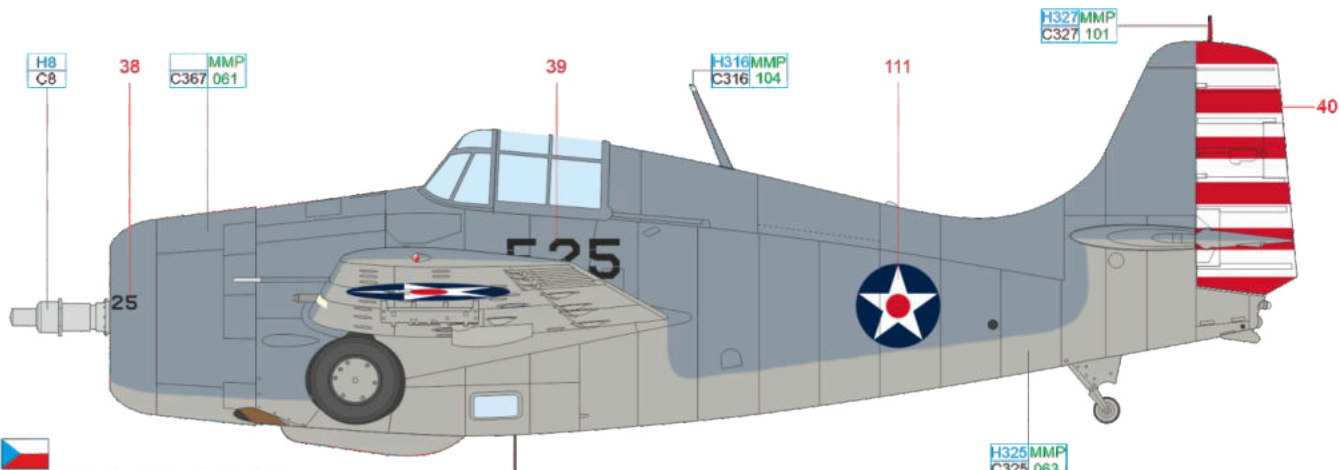

ČESKOU VERZI TEXTU NALEZNETE NA
www.eduard.com
 POD KATALOGOVÝM ČÍSLEM 11166

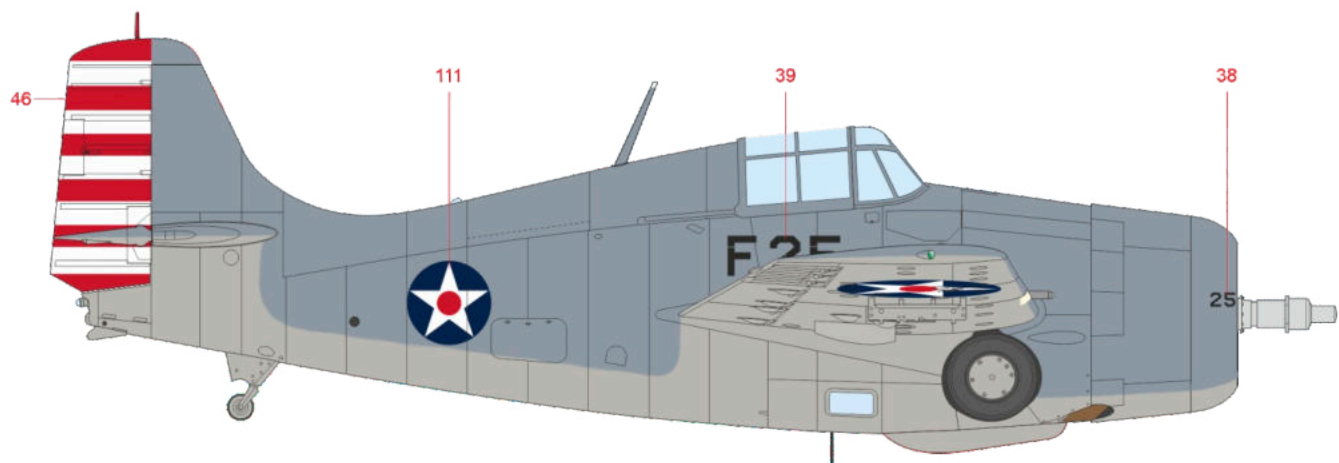
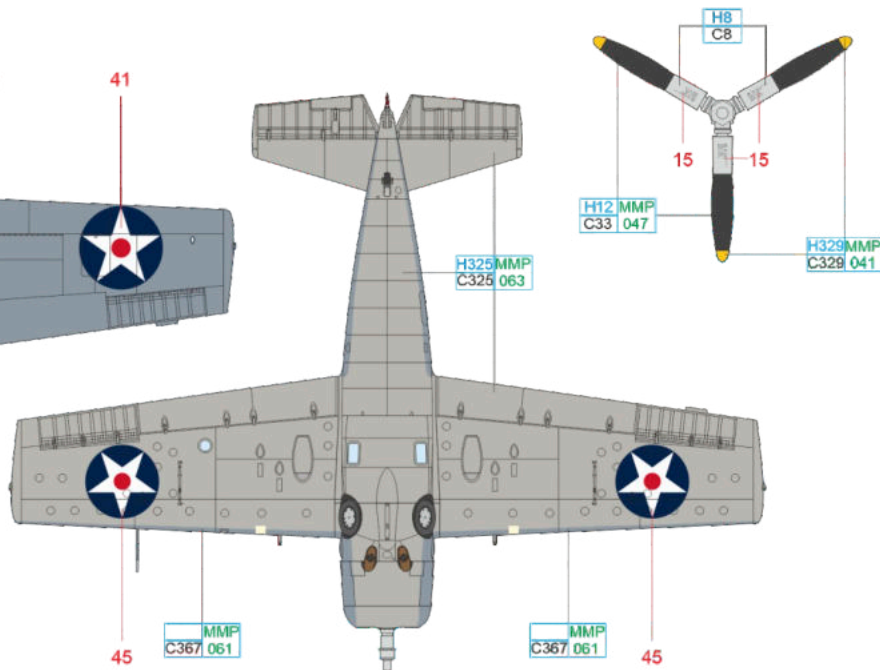
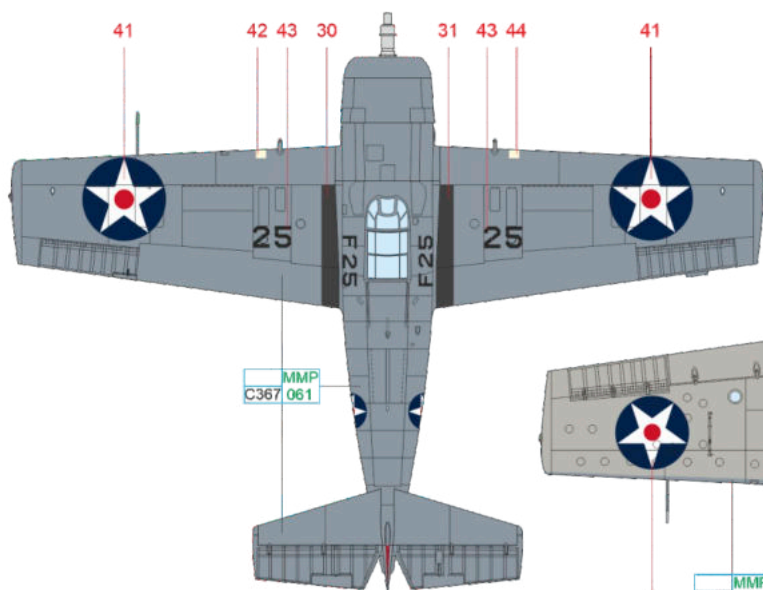

SILVER	H8 C8	GRAY	H325MMP C325 063	WHITE	H316MMP C316 104	BLUE GRAY	MMP C367 061	RED	H327MMP C327 101	BLACK	H12 MMP C33 047	YELLOW	H329MMP C329 041
--------	-------	------	------------------	-------	------------------	-----------	--------------	-----	------------------	-------	-----------------	--------	------------------

eduard

E F4F-3, BuNo. 3986, Lt. Albert Ogden Vorse, VF-2, USS Lexington (CV-2), May 1942

Albert Vorse was born on August 9, 1914, in Philadelphia, Pennsylvania and after he finished his studies at the Naval Academy in 1937, he was ordered on board of the USS Astoria heavy cruiser (CA-34). In March 1940 he was dispatched to the Pensacola base where he completed his pilot training. In 1941 he was assigned to VF-3. After the USS Saratoga (CV-3) was torpedoed by I-6 submarine in January 1942 and sent for repairs back to the USA part of VF-3 pilots, including their mounts was assigned to VF-2 on board of USS Lexington (CV-2). Therefore, within VF-2 operation out of USS Lexington the aircraft carrying VF-3 markings flew as well. Wildcat BuNo. 3986 originally was operated by VF-3 and assigned to Lt. Noyel Gayler therefore the kill markings under the canopy was actually his personal score. On USS Lexington "Fox 5" was assigned to Lt. Vorse who within VF-2 took part in the Battle of the Coral Sea where USS Lexington was sunken. After more than 76 years the shipwreck was found by Paul G. Allen on his research vessel R/V Petrel. The photographs released after researching Lady Lex capture a Wildcat marked F-5 (previous marking F-13) in which Lt. Vorse fought in the Battle of the Coral Sea and claimed one bomber and one fighter shot down. His total score at the end of the war was 11.5 kills.

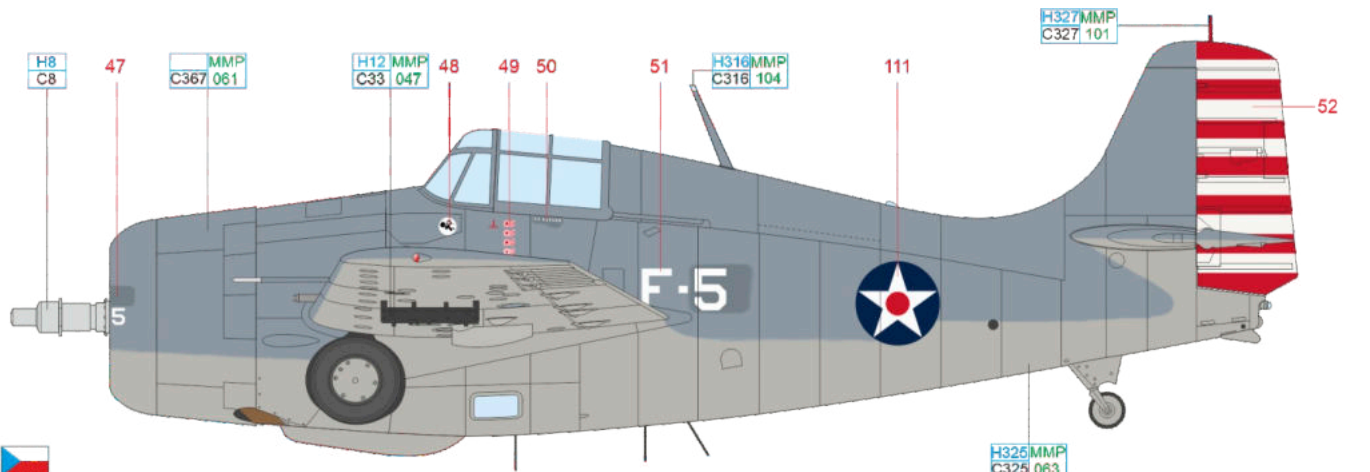

ČESKOU VERZI TEXTU NALEZNETE NA
www.eduard.com
 POD KATALOGOVÝM ČÍSLEM 11166

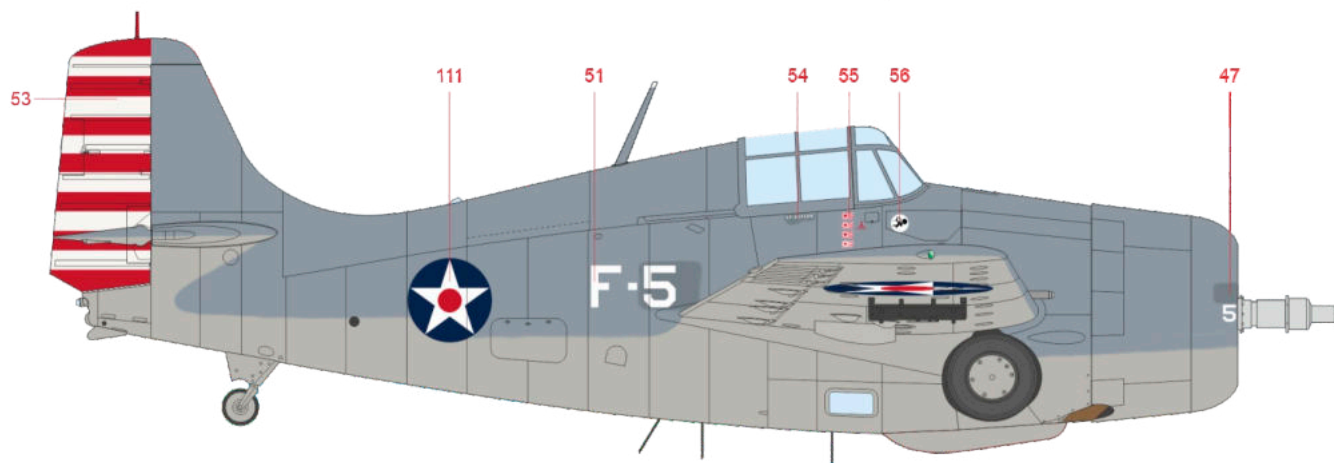
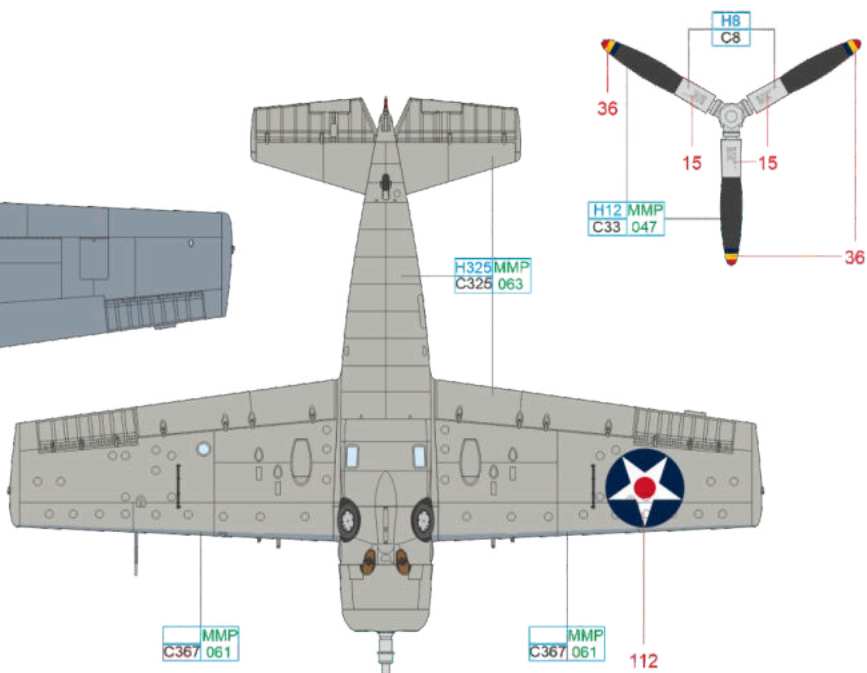
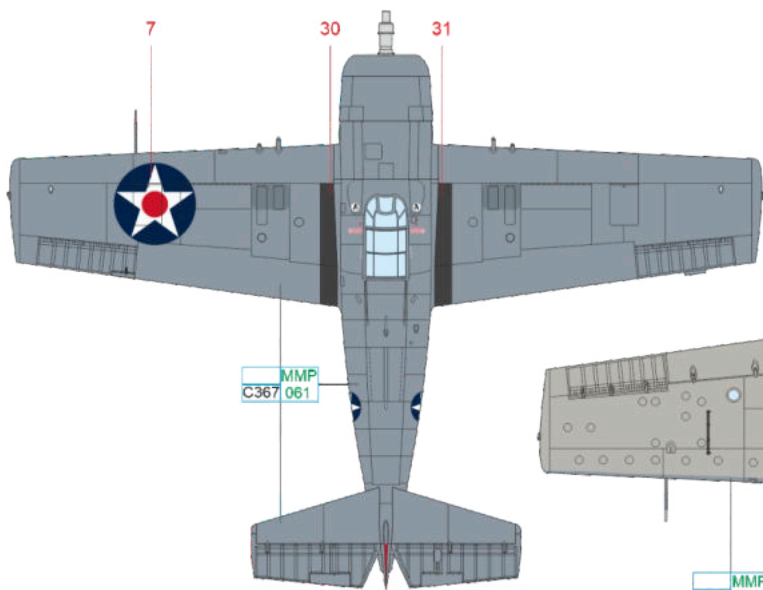

SILVER	H8 C8	GRAY	H325 MMP C325 063	WHITE	H316 MMP C316 104	BLUE GRAY	MMP C367 061	RED	H327 MMP C327 101	BLACK	H12 MMP C33 047
--------	----------	------	----------------------	-------	----------------------	-----------	-----------------	-----	----------------------	-------	--------------------

F F4F-4, BuNo. 5171., Lt. Cdr. John Smith Thach, VF-3, USS Yorktown (CV-5), May/June 1942

In May 1942 a new Wildcats F4F-4 with folding wings were delivered to VF-3. The handful of pilots of the emerging VF-3 squadron flew these aircraft at Kaneohe Bay base. The unit was commanded by John "Jimmy" S. Thach who developed the tactics known as Thach Weave, first time applied in combat during the Battle of Midway. It was a manner of mutual protection of the pairs of Wildcats against more agile Zero fighters. Mainly thanks to this tactic the Wildcats could defend themselves against the numerically superior Zeros while they escorted the first wave of bombers launched against the fleet of the Japanese carriers in the Battle of Midway. Thach himself claimed three Zeros shot down and other pilots of his section scored kills as well. At the controls of the Wildcat "Fox 1" "Jimmy" Thach shot down a B5N Kate bomber on his second sortie during the battle. In the period photographs of Jimmy Thach's Wildcat it is clearly visible that VF-3 insignia under the canopy was damaged. Nevertheless, our decal sheet contains its undamaged version too. Wildcats were camouflaged in Light Gray on the lower surfaces and Blue Gray on the side and upper surfaces. The national insignia in the form of the blue circles with white star and red circle in the center were painted on the fuselage and four positions on the wings. The additional marking was red and white stripes on the rudder. During the Battle of Midway these stripes were overpainted with the camouflage color and the red circles were deleted from the national insignia.

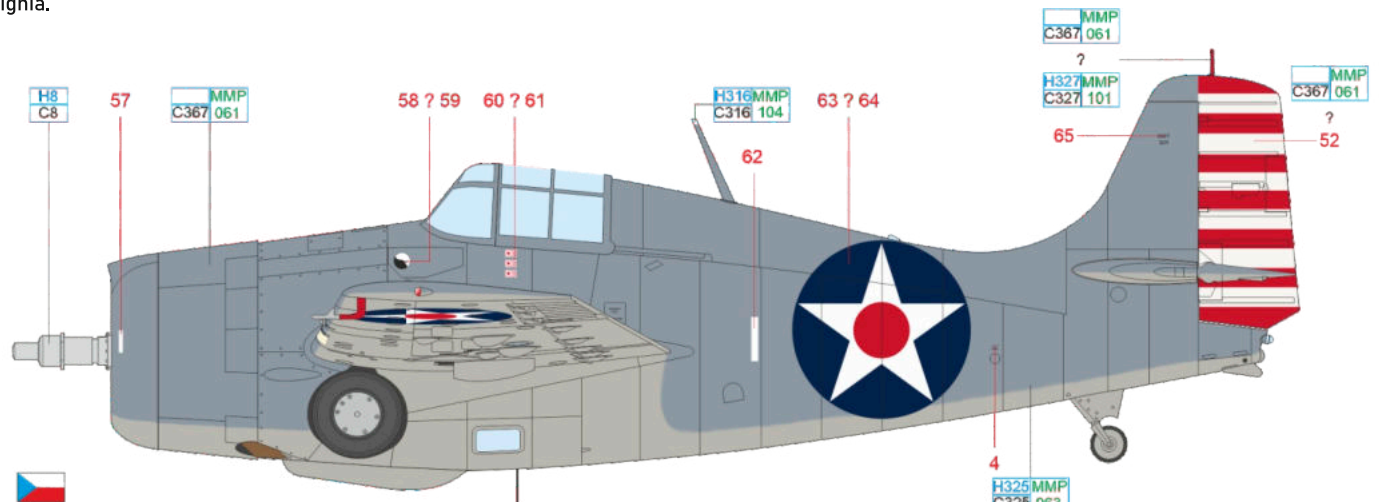

ČESKOU VERZI TEXTU NALEZNETE NA www.eduard.com POD KATALOGOVÝM ČÍSLEM 11166

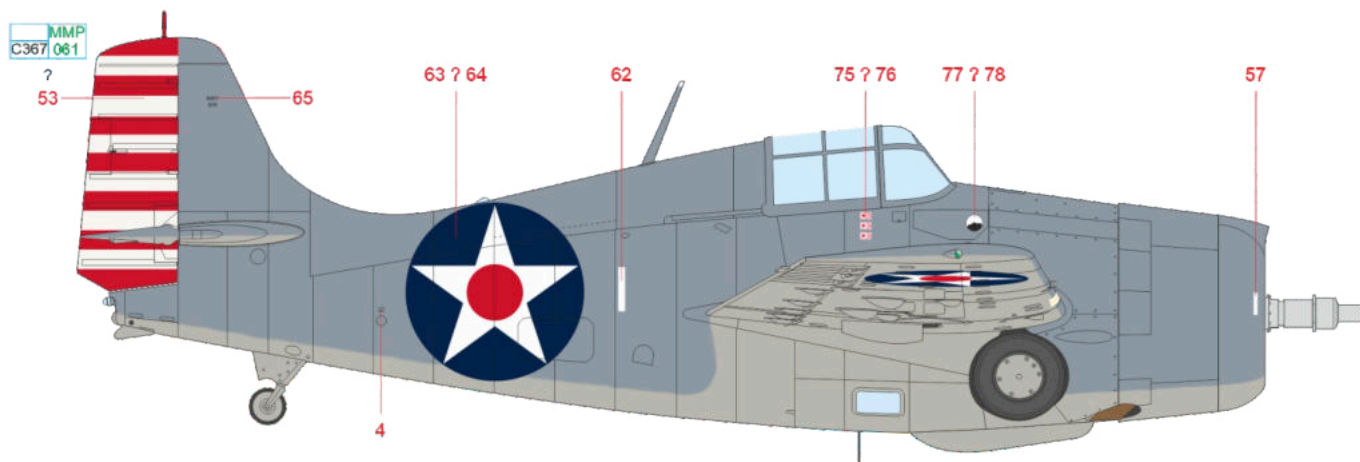
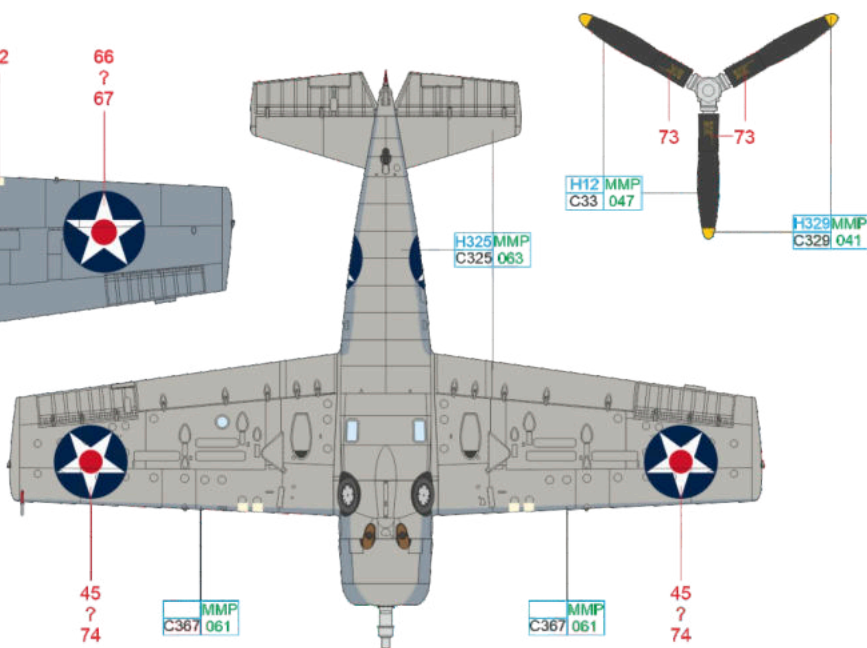
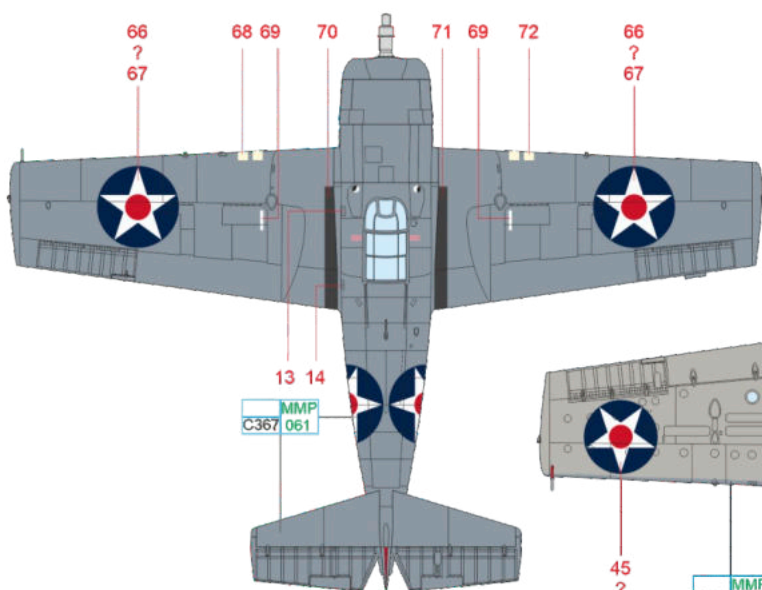

SILVER H8 C8 GRAY H325MMP C325 063 WHITE H316MMP C316 104 BLUE GRAY MMP C367 061 RED H327MMP C327 101 BLACK H12 MMP C33 047 YELLOW H329MMP C329 041

eduard

Another battle the USS Hornet (CV-8) took part in after the participation in the Doolittle bomber raid on Tokyo was Battle of Midway. VF-8 pilots were the least experienced fighters out of all deployed fighter units. Right at the beginning of the battle the squadron suffered heavy aircraft losses when after the botched escort of the bombers launched against the group of Japanese ships ten pilots got lost on the return flight. All of them had to perform the emergency landings on the ocean surface due to the exhausted fuel. Eight pilots were rescued even though some of them had to wait several days until the help arrived. During the Battle of Midway the red circle on the national insignia were already deleted as well as the red and white stripes on the rudder. The feature aircraft carried the Black Spade insignia in front of the wind shield.

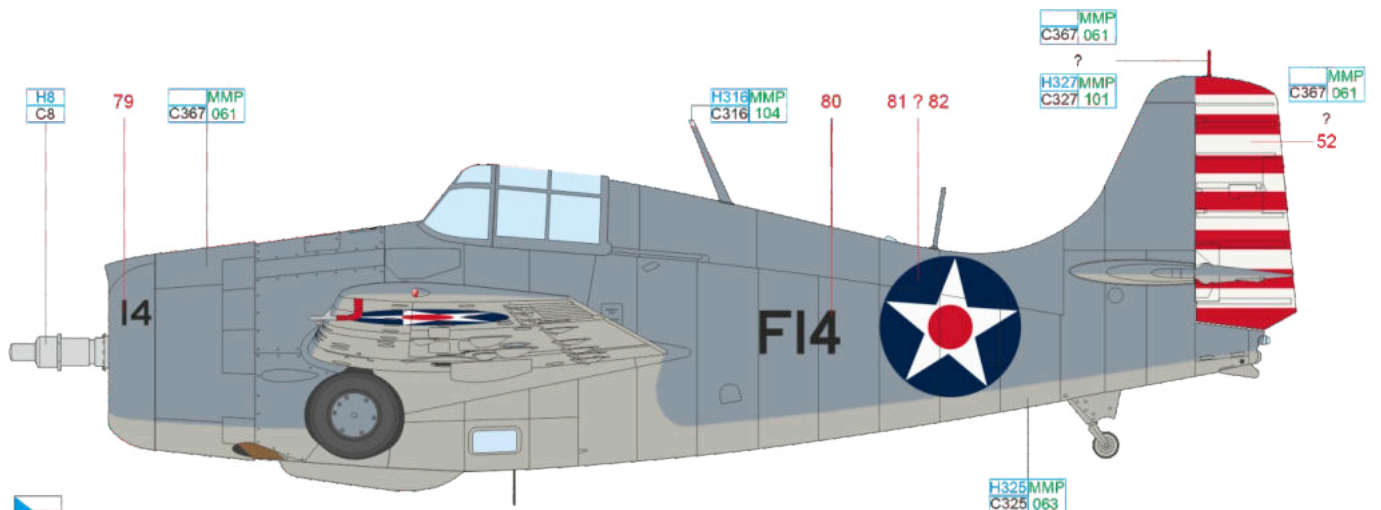

ČESKOU VERZI TEXTU NALEZNETE NA
www.eduard.com
 POD KATALOGOVÝM ČÍSLEM 11166

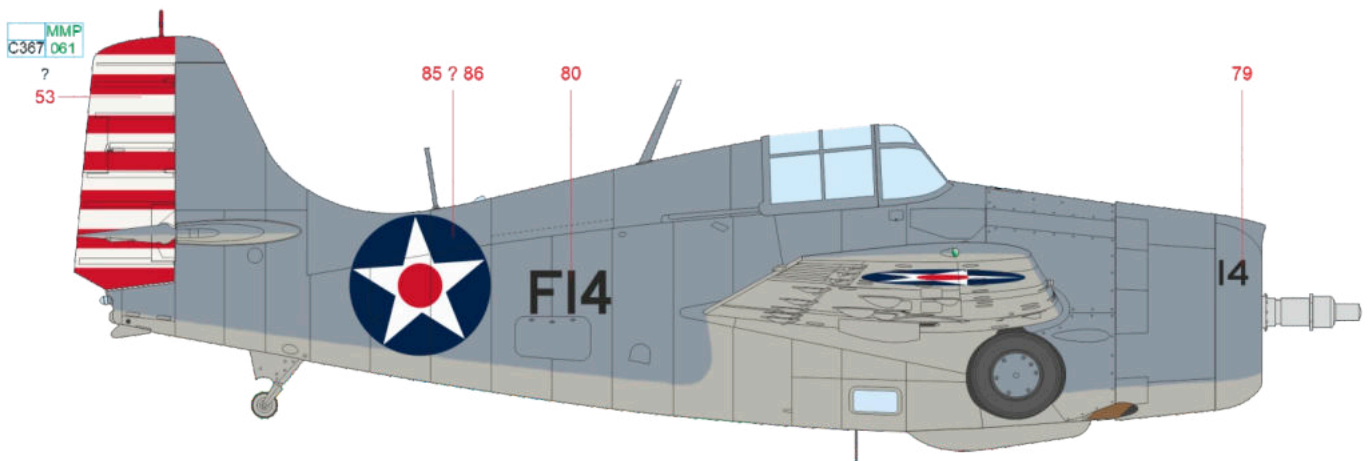
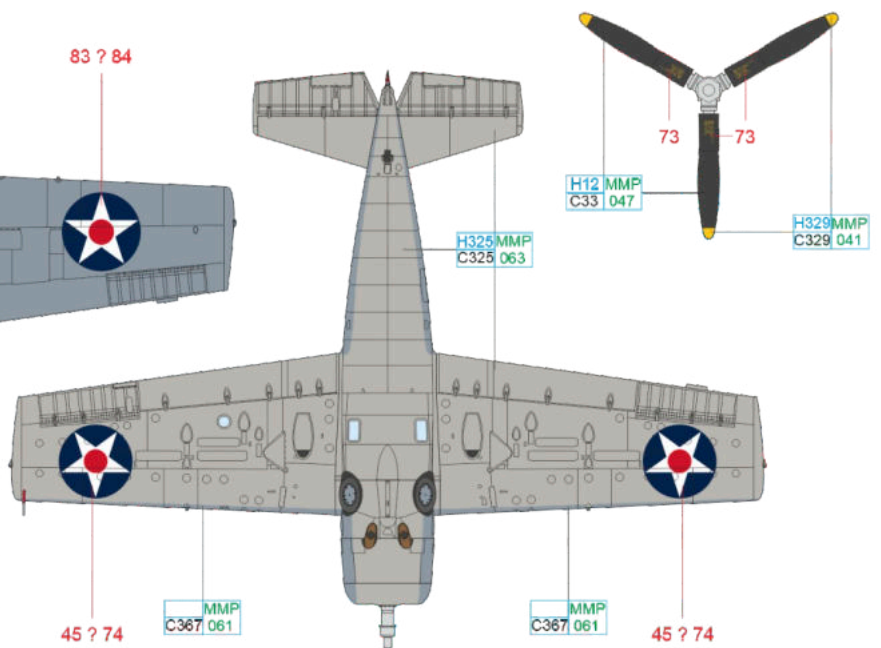
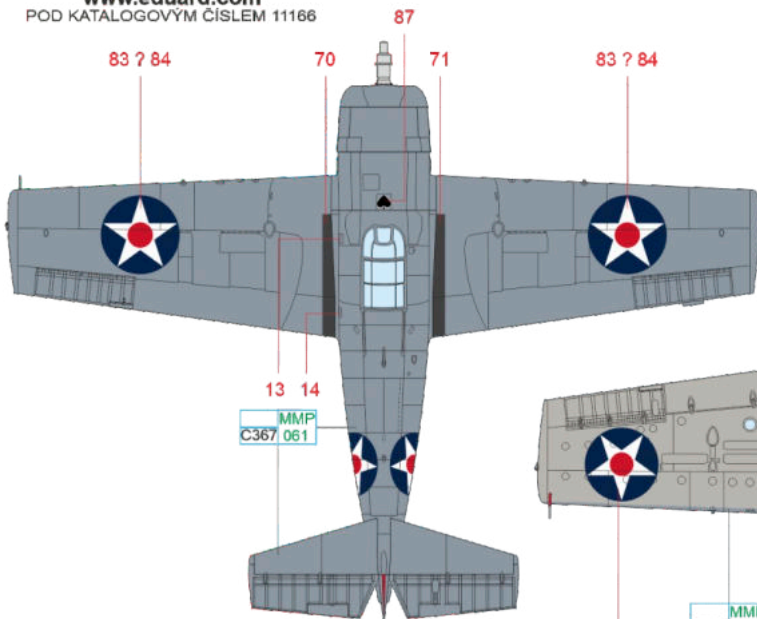

SILVER	H8 C8	GRAY	H325 MMP C325 063	WHITE	H316 MMP C316 104	BLUE GRAY	MMP C367 061	RED	H327 MMP C327 101	BLACK	H12 MMP C33 047	YELLOW	H329 MMP C329 041
--------	----------	------	----------------------	-------	----------------------	-----------	-----------------	-----	----------------------	-------	--------------------	--------	----------------------

H F4F-4, Lt. Walter Albert Haas, VF-8, USS Hornet (CV-8), June 1942

Collingswood, New Jersey native, Walter Albert Haas was the first Wildcat pilot to score a kill of the Zero fighter. It occurred on May 7, 1942, during the attack on Shōhō aircraft carrier while he flew with VF-42 off the USS Yorktown (CV-5) aircraft carrier. In June, during the Battle of Midway Lt. Haas still flew with VF-42 which was incorporated into VF-3. After the USS Yorktown was damaged, both VF-3 and VF-42 pilots were transferred on board of the USS Hornet (CV-8) where under the leadership of Lt. Cdr. Thach they formed the provisional unit designated VF-3-8-42. One of the unit's pilots was Lt. Haas who during the Battle of Midway shot down one B5N Kate. Six Japanese flags marking on his Wildcat represents the actual pilot's score of 4.83 kills i.e., four individual kills and two in the cooperation. The shots were taken by the crew of John Ford who recorded a documentary film shown in the movie theaters under the title "The Battle of Midway" already in September 1942. Interesting fact is that in the movie Lt. Haas's Wildcat did not carry the marking of any unit that participated in the battle. In the middle of June 1942, after the return to Pearl Harbor this provisional unit was disbanded, and Lt. Haas joined the new Navy pilots flight training program. After that he was commissioned to command the bomber squadron aboard the USS Ticonderoga (CV-14) where he flew until the end of war. Initially the Wildcat marked white 17 probably flew with VF-8. The original marking on the fuselage and the engine cowling was oversprayed with the camouflage paint.

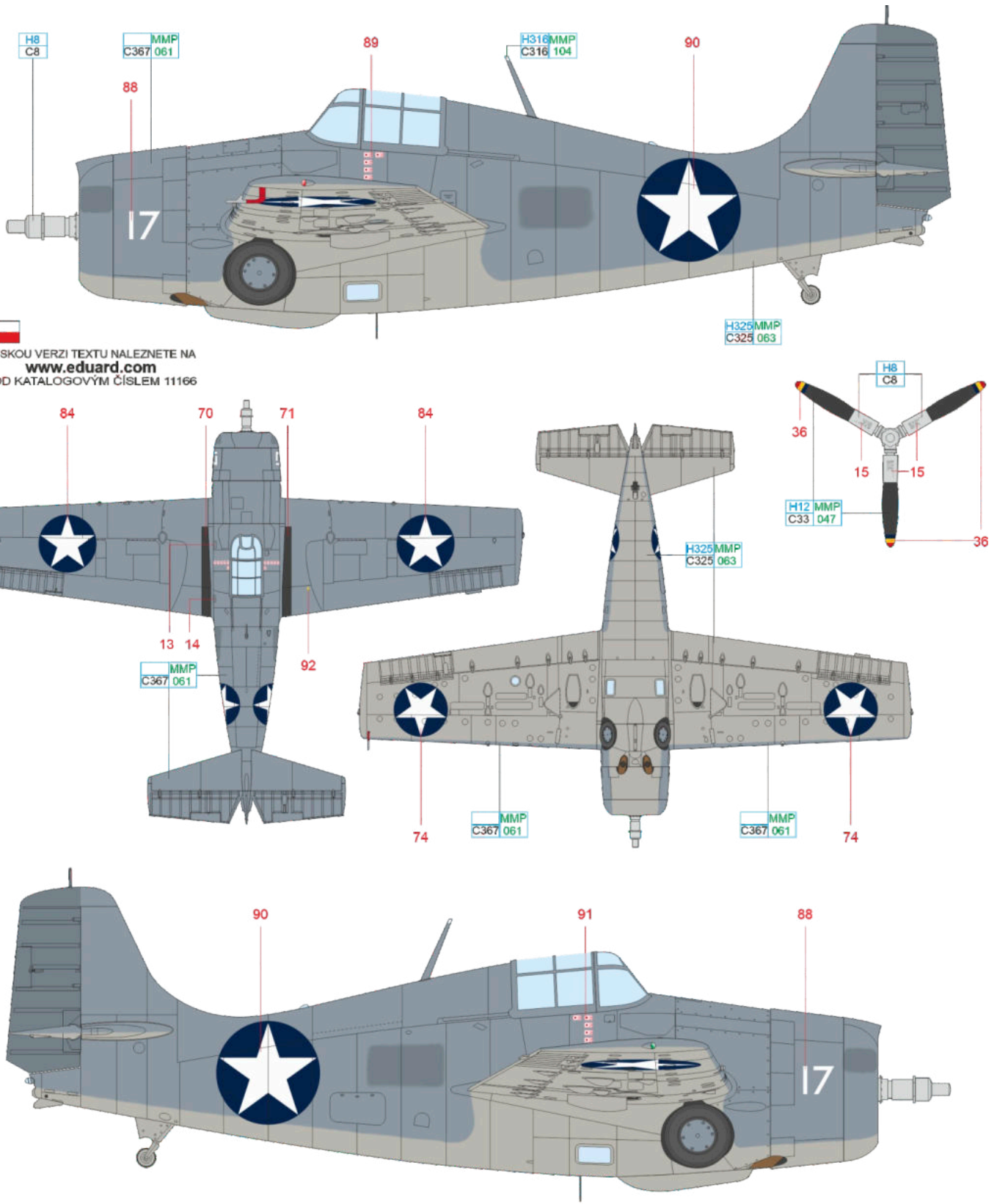

ČESKOU VERZI TEXTU NALEZNETE NA
www.eduard.com
 POD KATALOGOVÝM ČÍSLEM 11166

SILVER H8 C8 GRAY H325MMP C325 063 WHITE H316MMP C316 104 BLUE GRAY MMP C367 061 BLACK H12 MMP C33 047



F4F-4, Ens. Ralph McMaster Rich, VF-6, USS Enterprise (CV-6), April/June 1942

Ralph M. Rich was born on January 22, 1916, in Denmark, North Dakota. In October 1939, after he joined the US NAVY reserves, he was accepted to the pilot training which he completed on June 12, 1940. On November 28 of the same year, he boarded the USS Enterprise (CV-6) where he was assigned to VF-6. During the fighting in Pacific, he participated in the raid on Marshall and Gilbert Islands where he destroyed one Japanese bomber on the ground. His next mission was the attack on Japanese occupied Wake Atoll. This was followed by the VF-6 deployment from the deck of USS Enterprise during the Battle of Midway where Ens. Rich, in the cooperation with other two pilots shot down a B5N Kate bomber defending the formation of the US aircraft carriers. On June 18, 1942, during the shooting exercises at 5,000 feet above Kaneohe Bay base the wing of the Wildcat flown by Lt. Rich tore off. The aircraft crashed and the pilot perished. Ens. Rich flew the featured aircraft in April 1942 when the planes were camouflaged in Light Gray on the bottom surfaces and Blue Gray on the side and top surface. National insignia were painted on the fuselage, four positions on the wings and complemented with red and white stripes on the rudder. At the time of the Battle of Midway the rudder stripes were overpainted with camouflage paint red circles were deleted from the national insignia and the aircraft marking was changed to F-5. The national marking on the fuselage was larger, slightly moved forward so the original marking was partially visible. The aircraft number was painted on the starboard wing only.

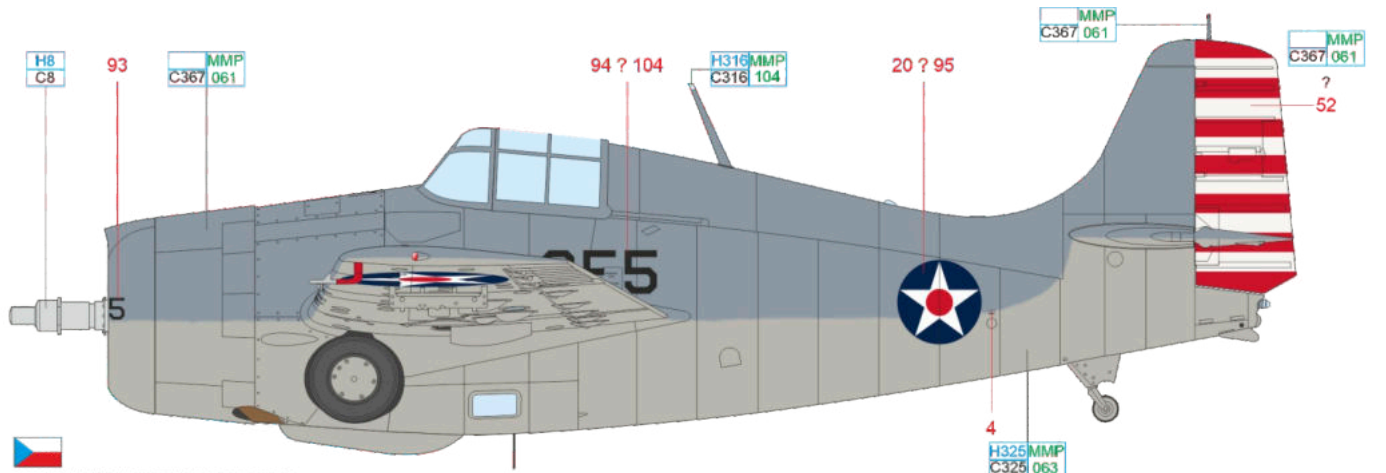

ČESKOU VERZI TEXTU NALEZNETE NA www.eduard.com POD KATALOGOVÝM ČÍSLEM 11166

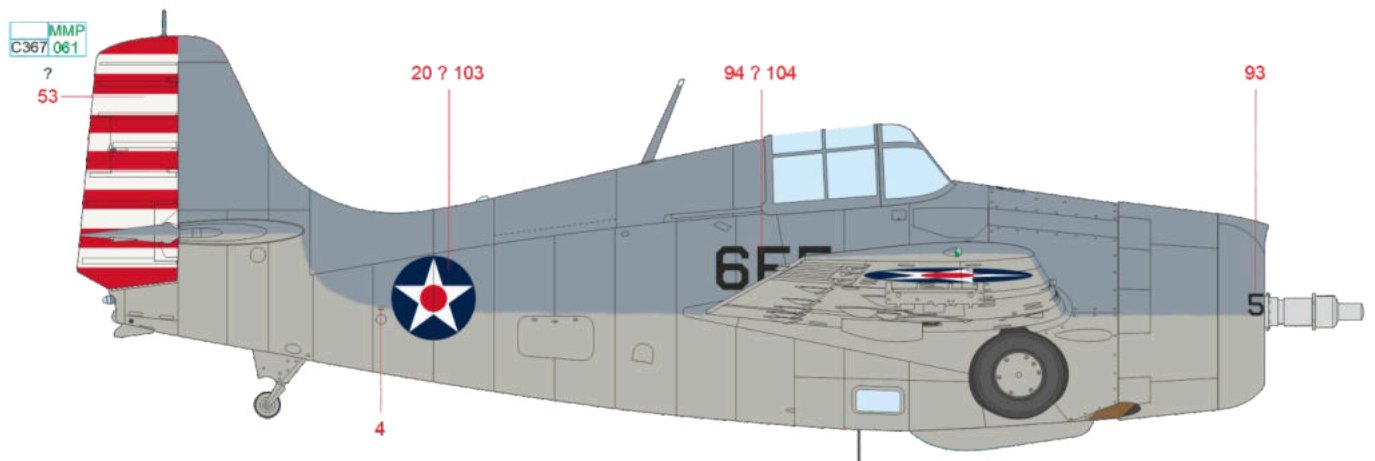
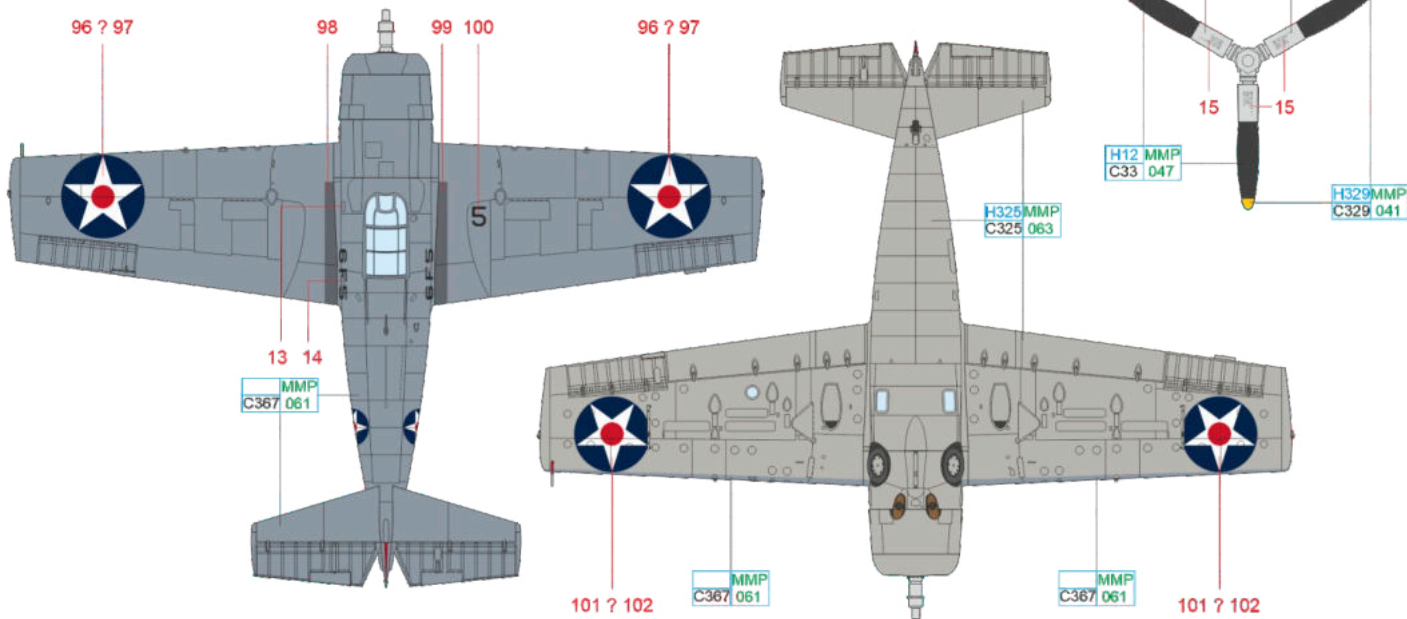

SILVER H8 C8 GRAY H325 MMP C325 063 WHITE H316 MMP C316 104 BLUE GRAY MMP C367 061 BLACK H12 MMP C33 047 YELLOW H329 MMP C329 041

J BuNo. 5244, Lt. William Nicholas Leonard, VF-3, USS Yorktown (CV-5), June 1942

Douglas, Arizona native, William Nicholas Leonard graduated from the Naval Academy in Annapolis in 1938. In June 1940 he started his pilot training at Pensacola base and successfully completed it in January 1941 at the 25 years of age. He was ordered to VS-41 aboard USS Ranger (CV-4) which operated SBU-1 bombers. After VF-41 was redesignated the original SBU aircraft were replaced with F4F. From June 1941 he flew with VF-42 which was during the Battle of Midway incorporated into VF-3 operating from the deck of USS Yorktown (CV-5). Leonard flew the featured Wildcat marked 13. It was a replacement and re-marked aircraft with its original numeral 26. At its controls Leonard increased his score by a B5N Kate bomber. This Wildcat did not carry VF-3 insignia and it cannot be excluded that after the transfer to USS Hornet Leonard painted four Japanese flags on the fuselage representing his current score. There is even a photograph showing Leonard posing in such decorated Wildcat on the board of USS Hornet couple of days after the Battle of Midway. In this case however it is not his personal aircraft. In 1943 Leonard flew with VF-11 on Guadalcanal and increased his score by two Zeros shot down.

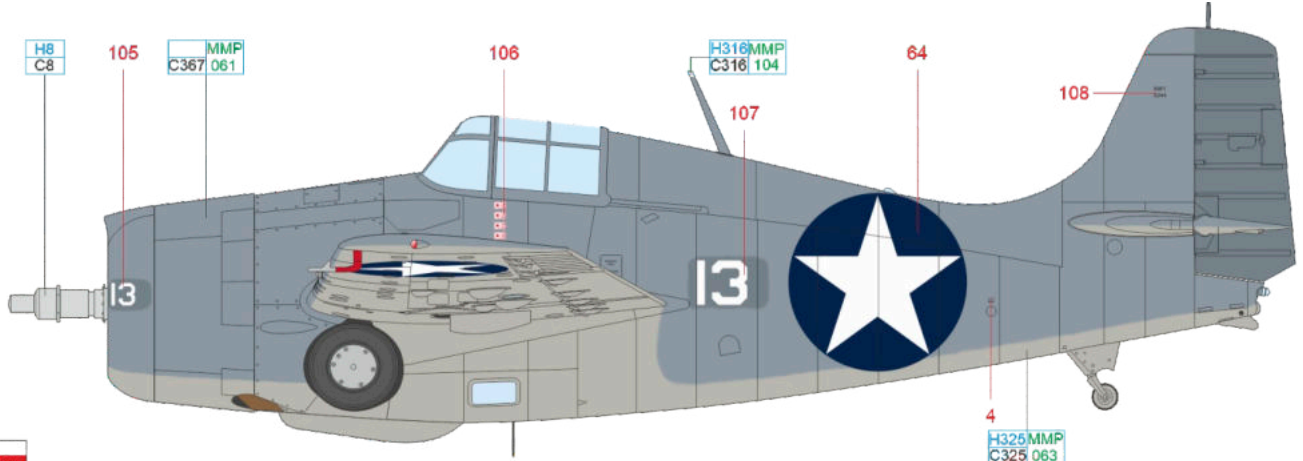

ČESKOU VERZI TEXTU NALEZNETE NA
www.eduard.com
 POD KATALOGOVÝM ČÍSLEM 11166

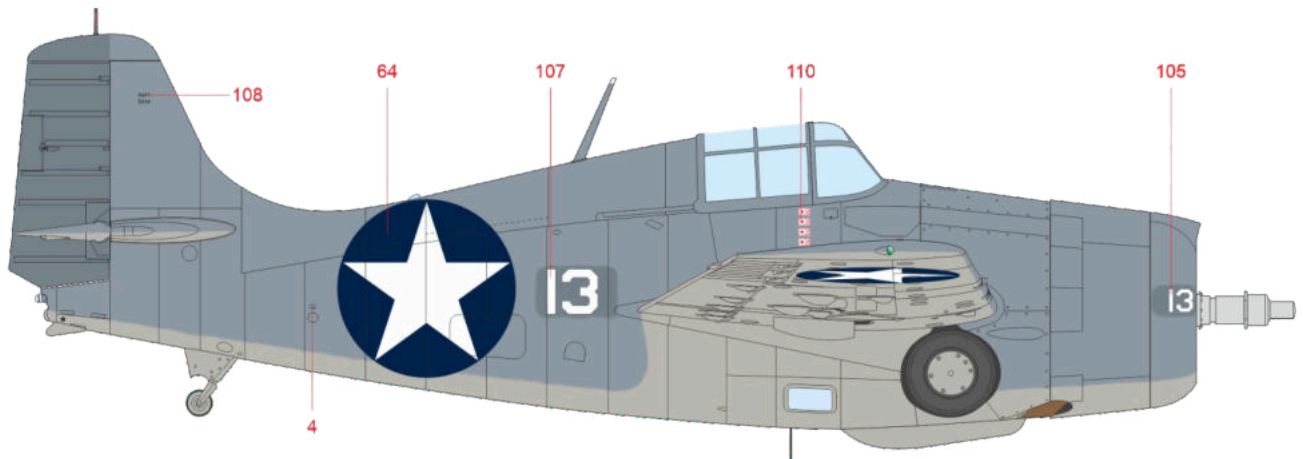
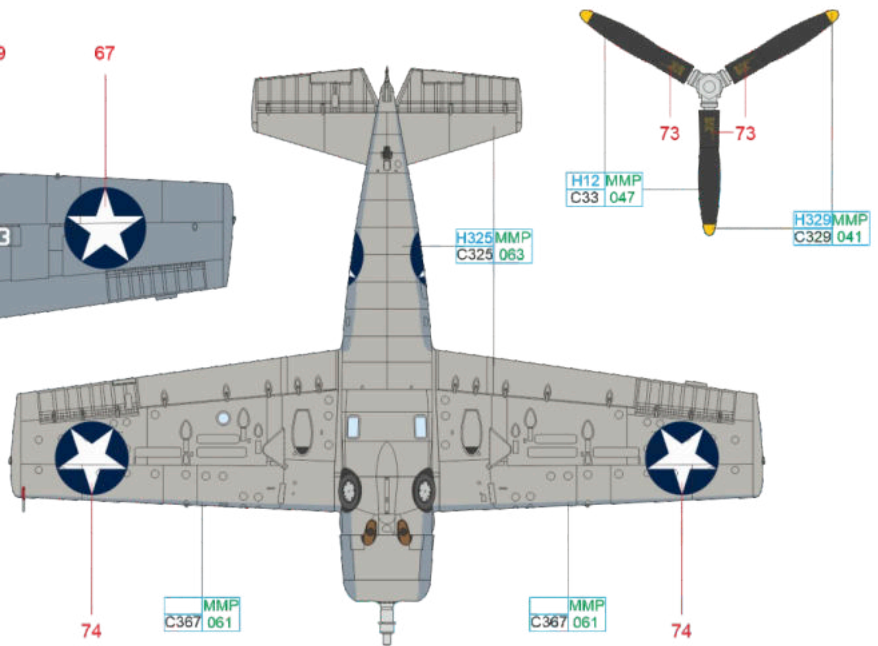
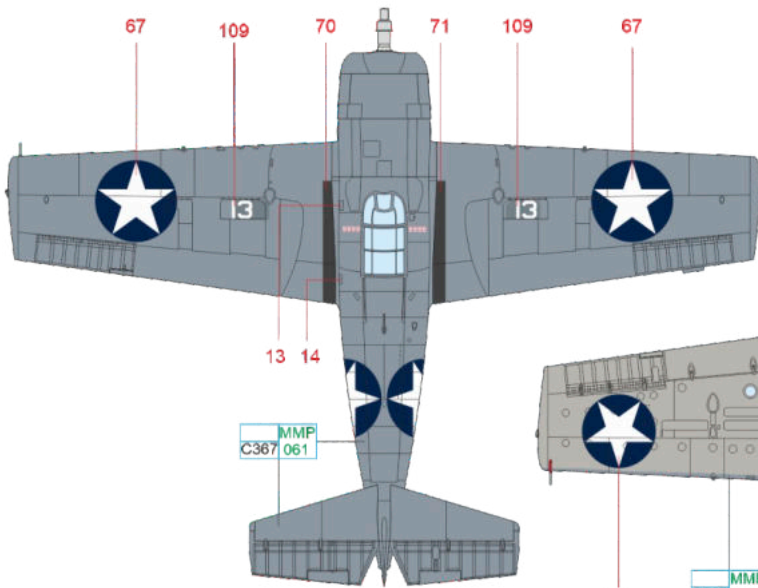

SILVER H8 C8 GRAY H325MMP C325 063 WHITE H316MMP C316 104 BLUE GRAY MMP C367 061 BLACK H12 MMP C33 047 YELLOW H329MMP C329 041