

**SIO**  
Models

# MiG-31 B/BS

## Mikoyan Foxhound



**1/48 UNASSEMBLED MODEL KIT**

INSTRUCTIONS



# Mikoyan MiG-31 B / BS

## Foxhound

### 米格31戰鬥機

The Mikoyan Gurevich MiG-31 (NATO reporting name: Foxhound) is a supersonic interceptor designed to replace the MiG-25 Foxbat. The project officially started in 1968 and was initially envisioned to be a heavy modernisation of the MiG-25P.

However, as development continued it became clear it would become a completely new aircraft sharing only the overall mission of being a supersonic interceptor. The first prototype (at that point still known as MiG-25PM) made its maiden flight on 16th September 1975.

One of the main functions of the new interceptor was the ability to track bomber sized targets at 120 kilometres and fighters at 90 km. In order to meet this demand, a very advanced and powerful radar was needed and it was decided to base this new radar on phased array technology. The radar, called "Zaslon", became the first phased array radar to be fitted and operationally used, on a fighter aircraft. The MiG-31 was also required to cruise at Mach 2.35 and have a combat radius of 700 kilometres at that speed with an effective maximum speed of Mach 2.83.

Before the MiG-31 even passed state trials Mikoyan-Gurevich was looking into ways to modernise and expand the capabilities of the aircraft. One of these was the MiG-31B program which was as a response to the reveals done by Adolf Tolkachev, an engineer turned spy, that provided the CIA with highly detailed information on the MiG-31's Zaslon radar and other systems developed by Phazotron.

The MiG-31B modernisation took the existing airframe and improved upon the electronics and added a refuelling probe that had already been tested and produced in the "Izdelie 01DZ" modification. The electrical changes made improved the capabilities of the datalink, navigation and computers used for radar and weapon systems. The datalink was now able to transfer information to other aircraft and ground base stations. It was also able to fire upon a target with radar information transferred from another aircraft or ground system(s).

MiG-31B frames replaced MiG-31DZ production in 1990. Operational MiG-31 airframes underwent modernisation to B standard but these frames, however, did not get the refuelling probe as this required a new build airframe like the B variant. It did however receive all the electrical improvements that the B variant had. They were designated MiG-31BS.

Externally to Russia, the only other operator of the Foxhound is the Kazakhstani Air Force. In Russia, all remaining MiG-31B frames were now modernised to MiG-31BM standard whilst the MiG-31BS was upgraded to what is, unofficially, called MiG-31BSM. These variants are included in the first MiG-31 boxing, AMK kit number 88003.

米高揚、格列維奇，米格-31（北約代號：獵狐犬），本來是一款用於取代米格-25狐蝠戰鬥機而設計的新型超音速截擊戰鬥機，此項目開展於1968年，當時人們將此項目視為是米格-25的重型現代化新定向。然而，隨著技術的不斷發展，此項目很明顯地，已經開發出了一款全新的戰鬥機，而其當時的主要任務就是負責超音速截擊。米格-31的原型（當時仍然被稱為米格-25PM）在1975年9月6日進行了首次飛行。

作為一款新型的截擊戰鬥機，其主要的職能之一，就是能夠追蹤到在半徑120千米範圍內與轟炸機體型大小相近的飛機，及在半徑90千米範圍內的戰鬥機。為了滿足這一種要求，需要非常先進和強大的雷達設備及雷達基地所提供的相控陣技術支持。米格-31是第一款配備了相控陣技術雷達(Zaslon)並且正式投入使用的戰鬥機。米格-31截擊戰鬥機的正常飛行速度達到2.35馬赫，在此速度下，作戰半徑範圍為700公里，而最高速度還可以達到2.83馬赫。

在米格-31通過審批之前，米高揚與格列維奇一直在研究更現代化及性能更佳的飛機，然而在這時，參與MiG-31B項目的雷達專家阿道夫·托爾卡切夫突然叛變，給美國中央情報局提供了極其詳盡的MiG-31 Zaslon雷達的資料，以及雷達製造商Phazotron公司正在開發的其他項目的相關資料。

米格-31B的現代化方案，採用現有的機身改進其電子設備並增加了更先進的空中加油管設備，此設備是根據現在有的"Izdelie 01DZ"改良而成的。由於電子設備的改進，所以米格-31B的數據自動傳輸裝置，用於控制導航、雷達及武器系統的主電腦的性能也得到了很大的改進。改進後的數據自動傳輸裝置能夠將資料傳輸到其他飛行器以及地面基地，同時也可以由其他飛行器或地面基地通過雷達進行數據傳輸而對目標開火。

1990年生產的米格-31B框架取代了MiG-31DZ，使得米格-31的機身進行了B型號標準的現代化改造，除了部分框架未進行改造。然而，這一款沒有裝配空中加油管的新款戰鬥機，給人們的感覺更像是B型號的變體，因為它除了空中加油管外擁有B型號的一切功能，人們最終給它命名為米格-31BS型號。

除了俄羅斯之外，只有哈薩克斯坦空軍在使用獵狐犬戰鬥機。在俄羅斯，剩下的所有米格-31B型號均已升級為米格-31BM型號，而原來的BS型號也被升級為了BSM型號。上述的型號，在AMK-88003此款模型的彩盒上均有提及。

This kit provides a choice of 3 types of markings. Select one before assembly.  
本模型提供3種塗裝，請於組裝前選擇合適的塗裝。

**A** MiG-31BS "16 Blue" Russian AF, Chelyabinsk-Shagol AB 2014

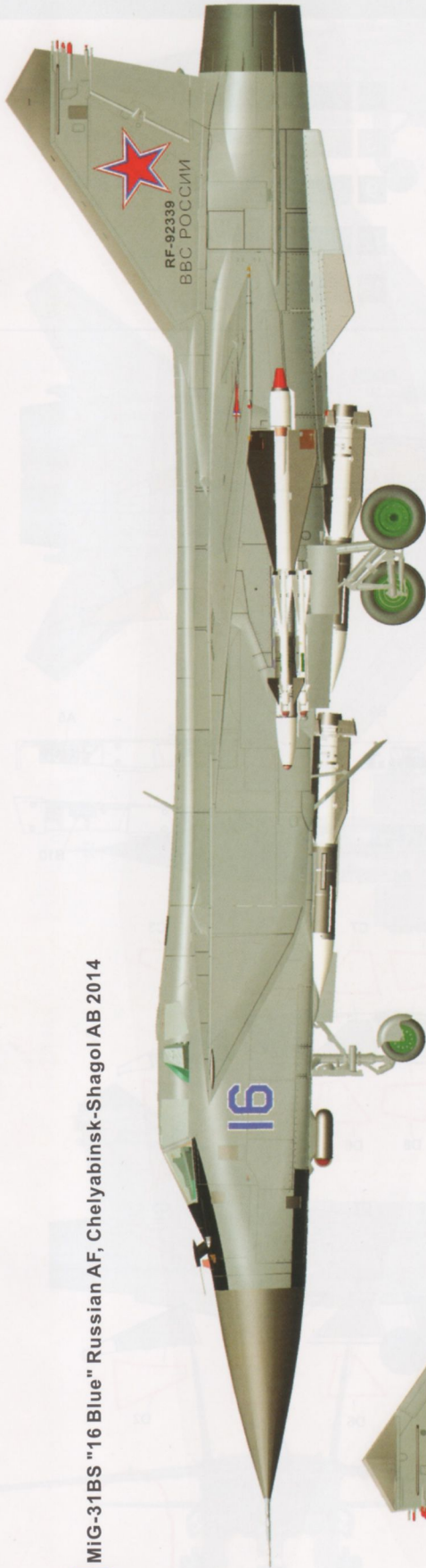

**B** MiG-31BS "23 Red" Kazakhstan Air Force 2012



**C** MiG-31B "73 Blue", one of several operated by the training unit at Savasleyka AB





★ 產品不適合8歲以下的兒童。  
 ★ 產品中含有帶尖點的小零件。  
 ★ 對於3歲以下兒童當心因窒息產生的危害。

NOT SUITABLE FOR CHILDREN UNDER 8 YEARS OF AGE  
 BEWARE: CONTAINS SMALL, SHARP PARTS  
 CHOKING HAZARD FOR THOSE UNDER 3 YEARS!

### PAINT AND COLOR USED

<b>1</b> 燒鐵色 Burnt Iron	<b>2</b> 銀色 Silver	<b>3</b> 黑色 Black
<b>4</b> 淺灰色 Light Grey FS 36622	<b>5</b> 草綠色 Willow Green FS 14187	<b>6</b> 交通灰色 Overall Light Grey FS 36493
<b>7</b> 綠松石藍色 Emerald Green	<b>8</b> 橙色 Orange	<b>9</b> 玄武岩灰色 Basalt Grey FS 26132
<b>10</b> 紅色 Red	<b>11</b> 白色 White	<b>12</b> 金屬 Steel
<b>13</b> 金屬灰 Metallic Grey	<b>14</b> 鋁合金色 Matt Aluminium	<b>15</b> 深灰色 Dark Grey

### Galaxy Canopy Mask 星河遮蓋貼

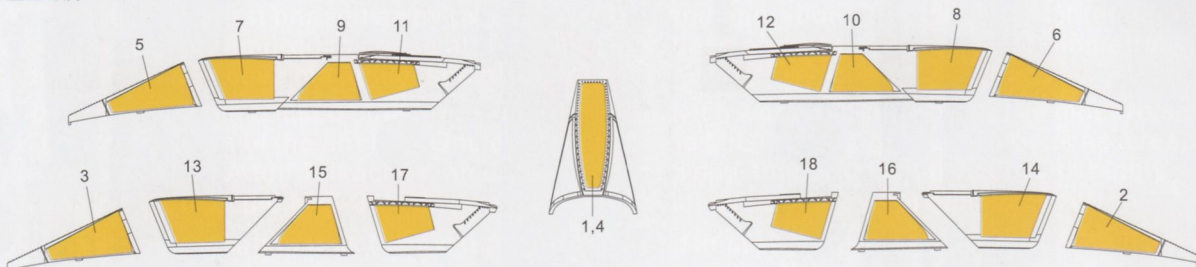

### Cockpit and Canopy Decals Instructions 座艙位置水貼紙位置說明

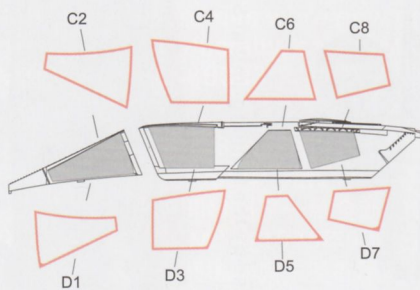
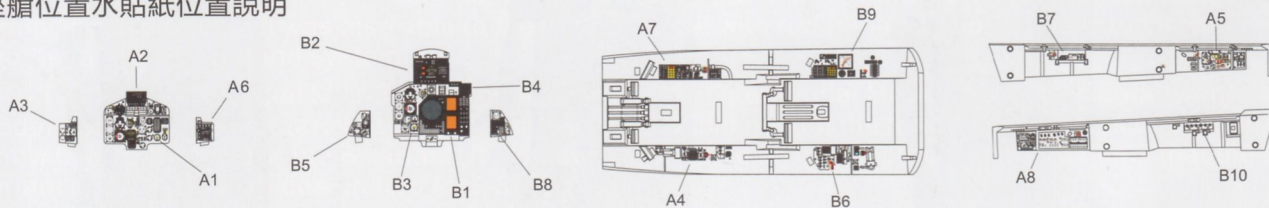

Canopy-outer side  
 外部粘貼編號

Canopy-inner side  
 內部粘貼編號

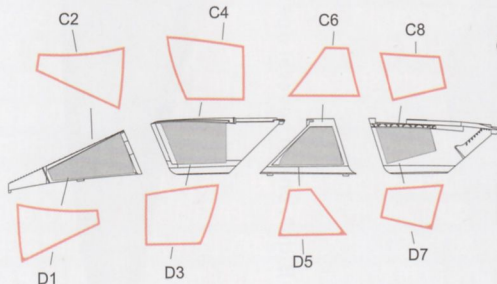
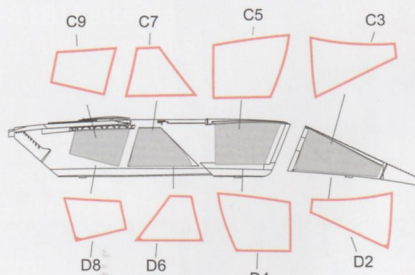

Canopy-outer side  
 外部粘貼編號

Canopy-inner side  
 內部粘貼編號

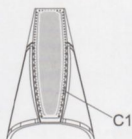
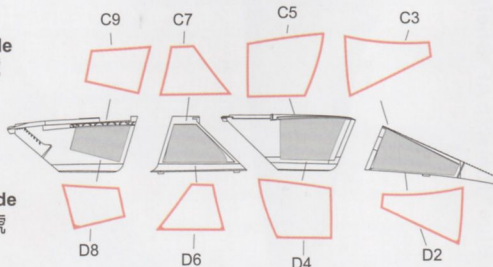

Front E1



Rear E2

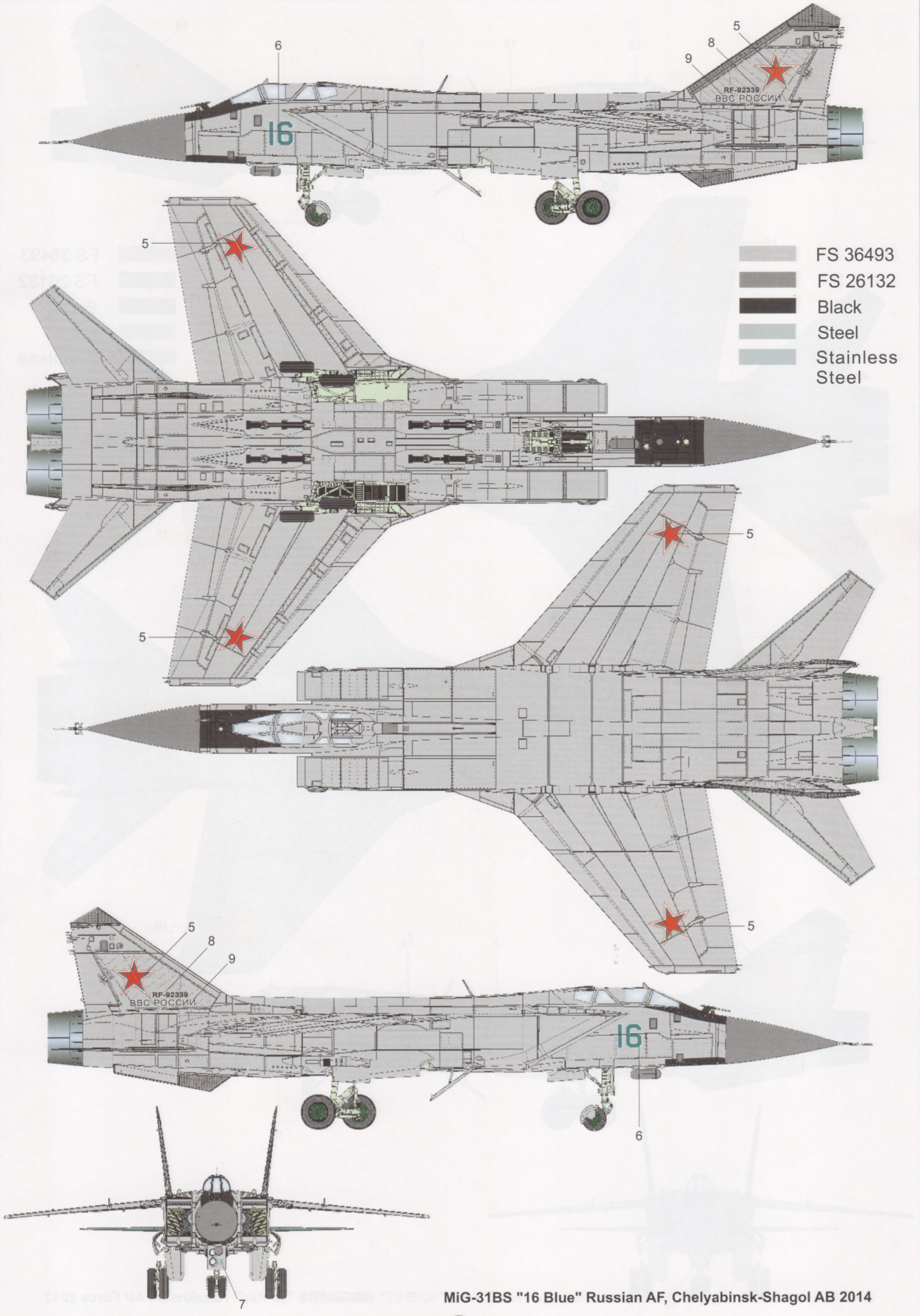

MiG-31BS "16 Blue" Russian AF, Chelyabinsk-Shagol AB 2014

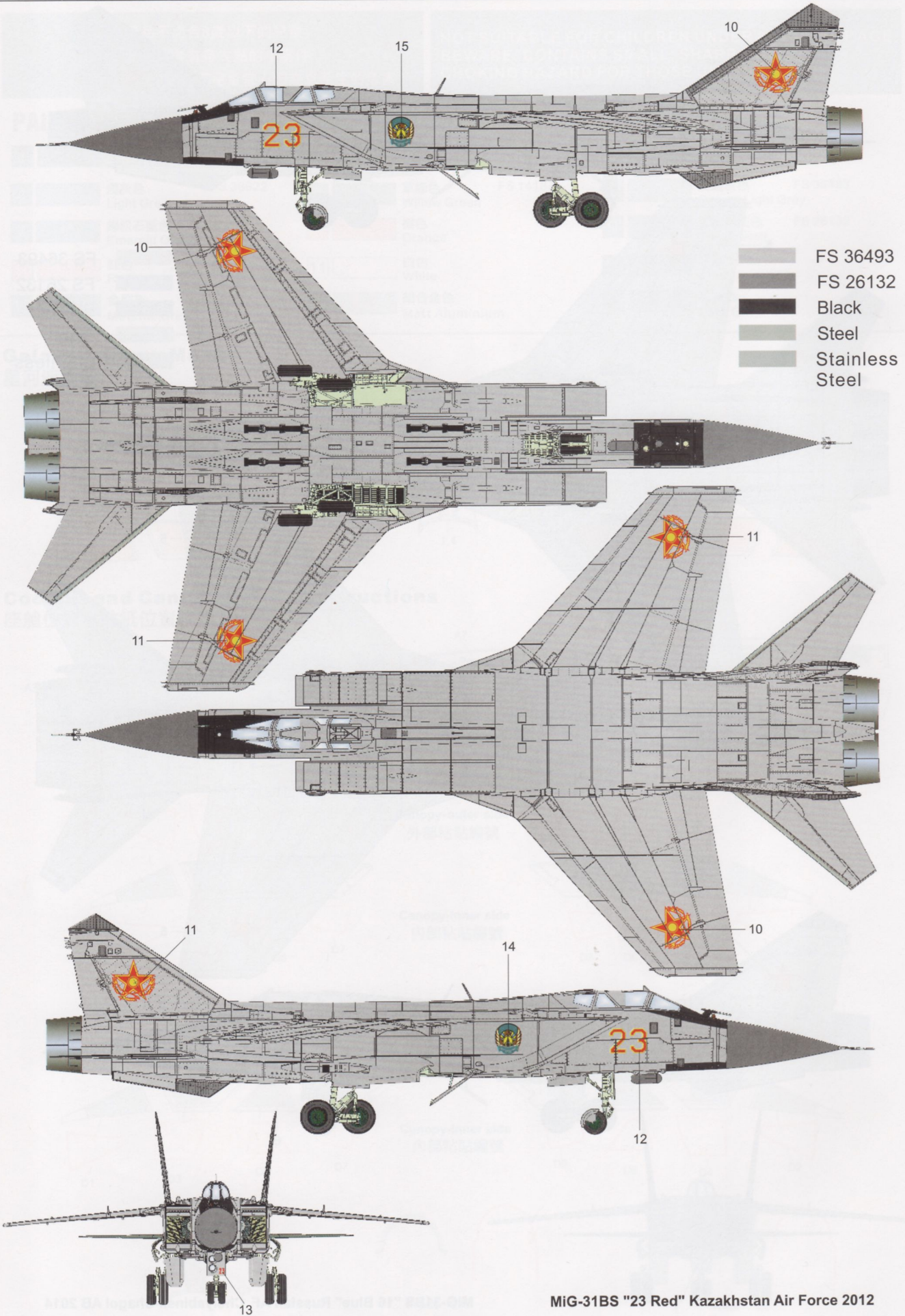

MiG-31BS "23 Red" Kazakhstan Air Force 2012



# 1 Engine 引擎

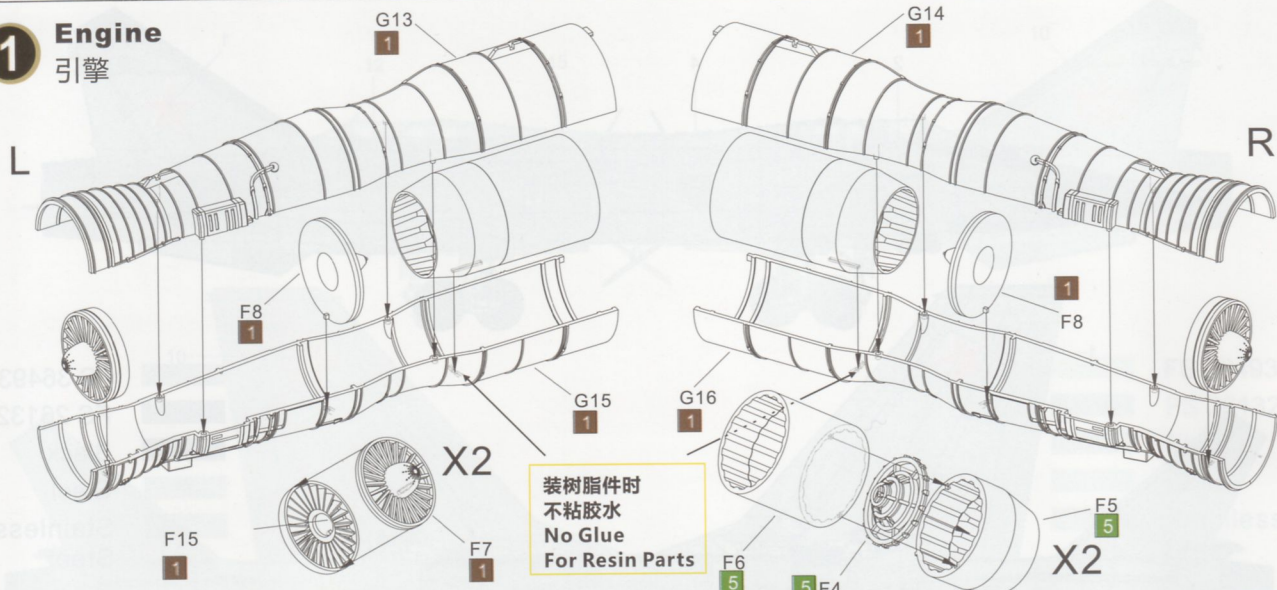

# 2 Port Air Intake 左入風槽

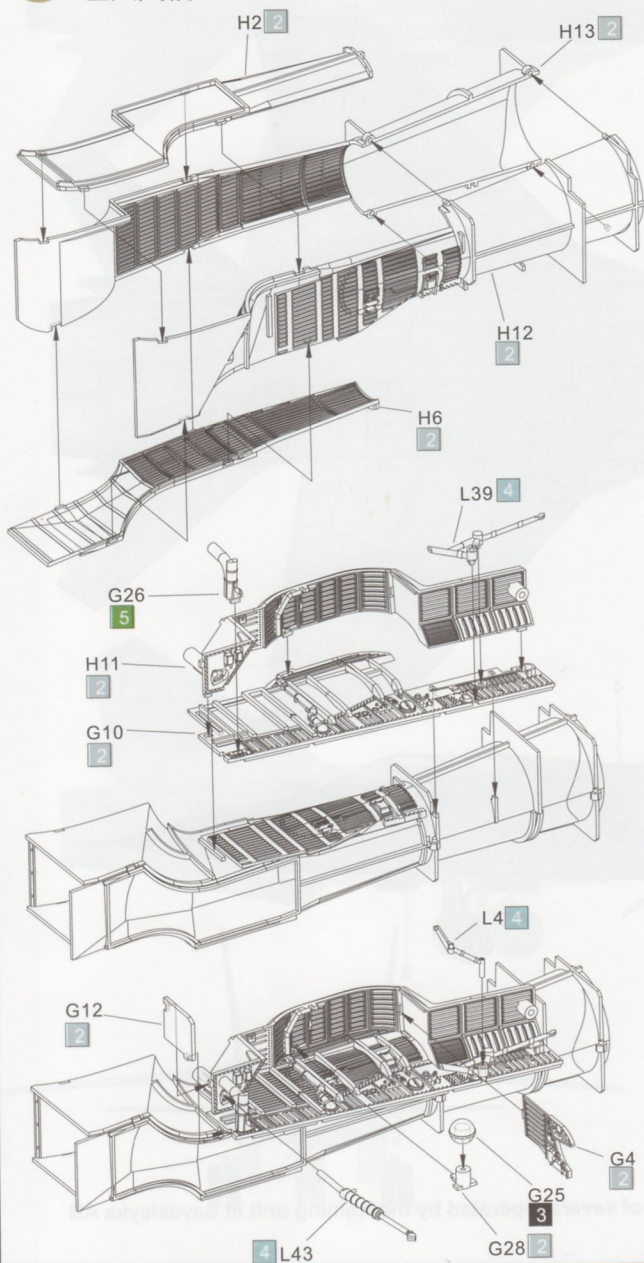

# 3 Starboard Air Intake 右入風槽

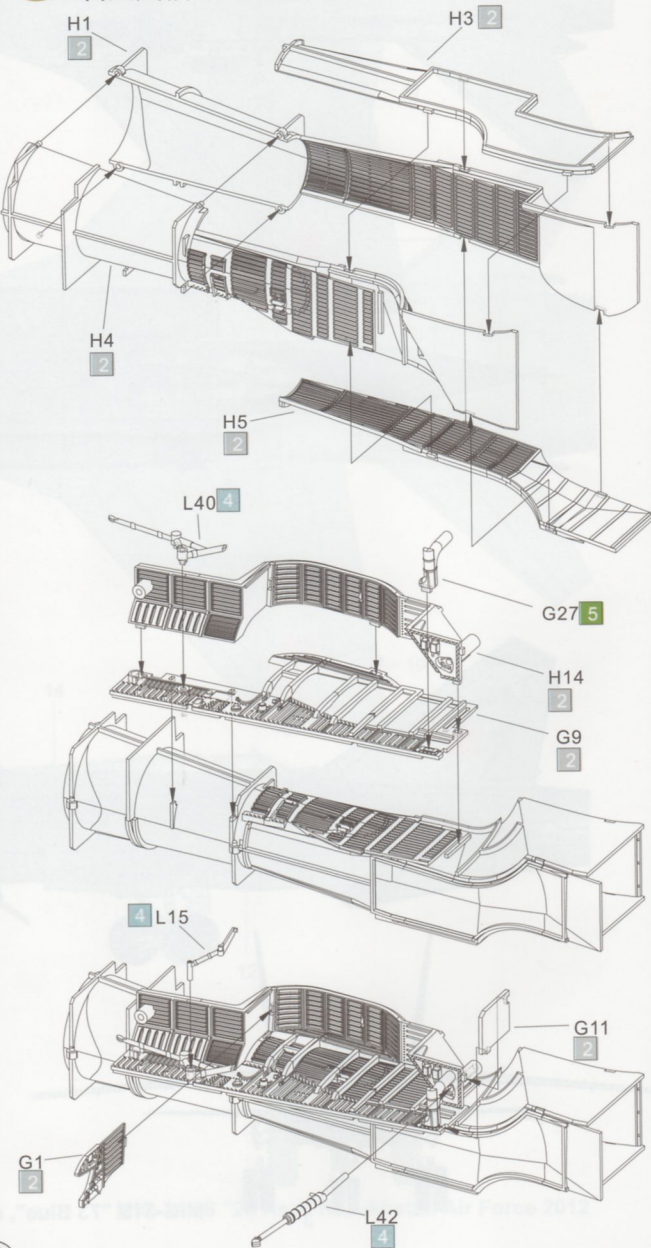



## 4 Lower Fuselage 下機身

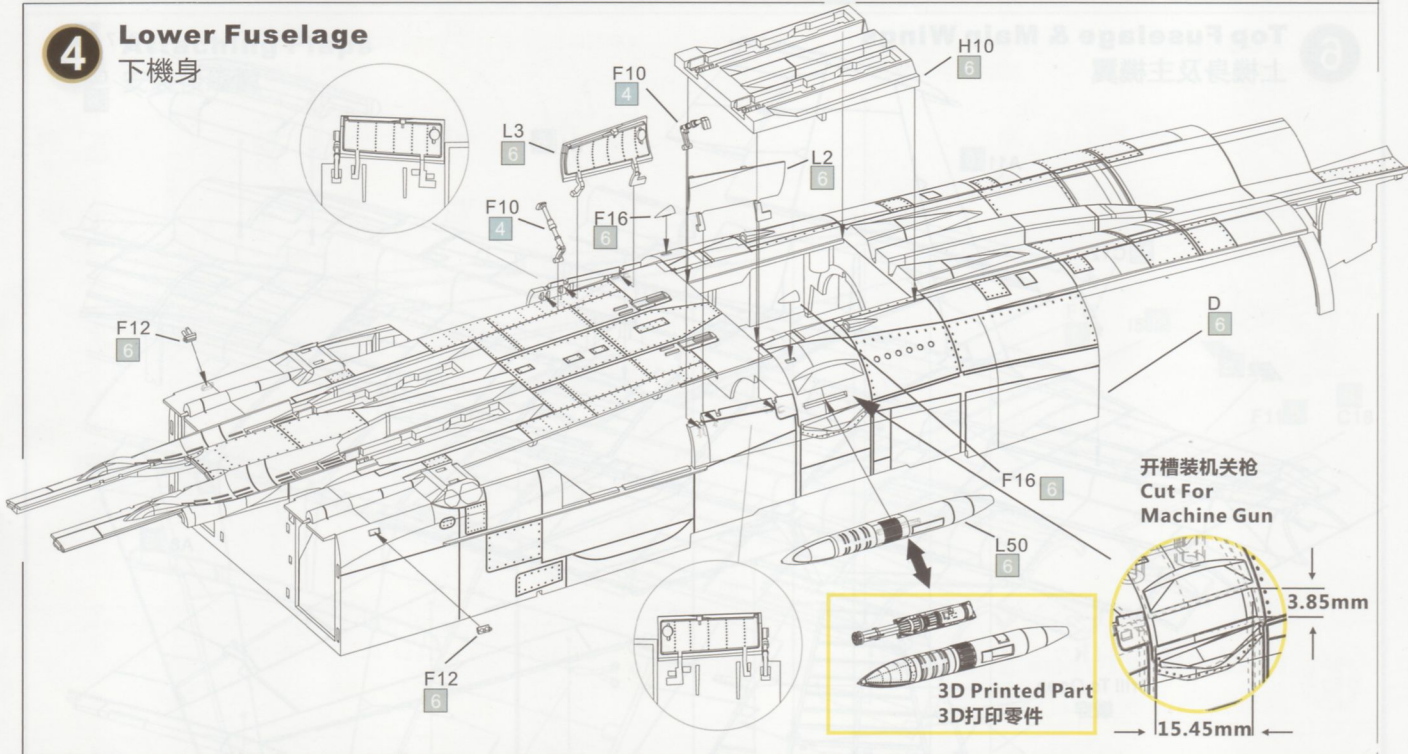

## 5 Placement of the Nose Landing Gear, Air Intakes and Engine. 組裝前起落架倉，入風槽及引擎

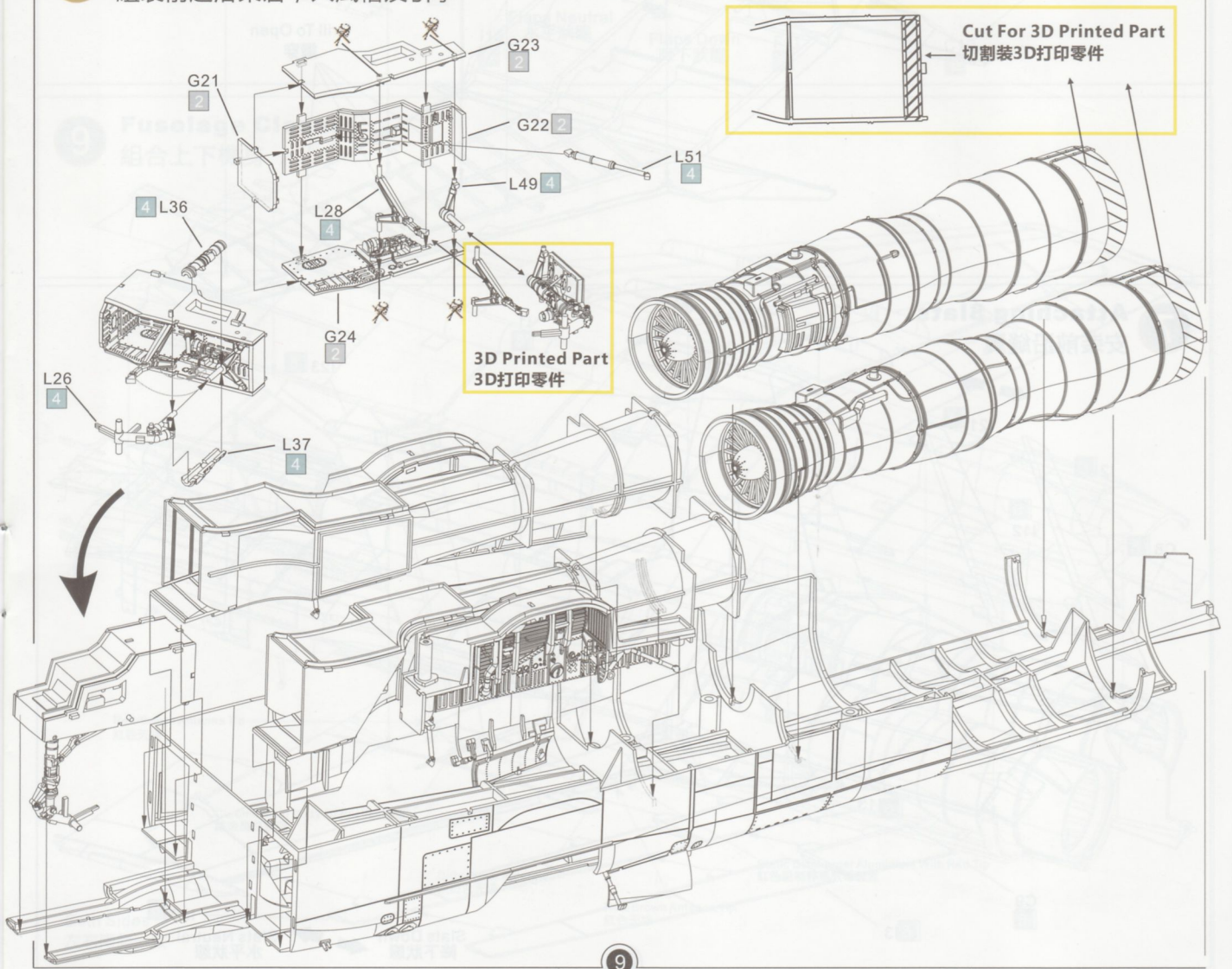

## 6 Top Fuselage & Main Wings

上機身及主機翼

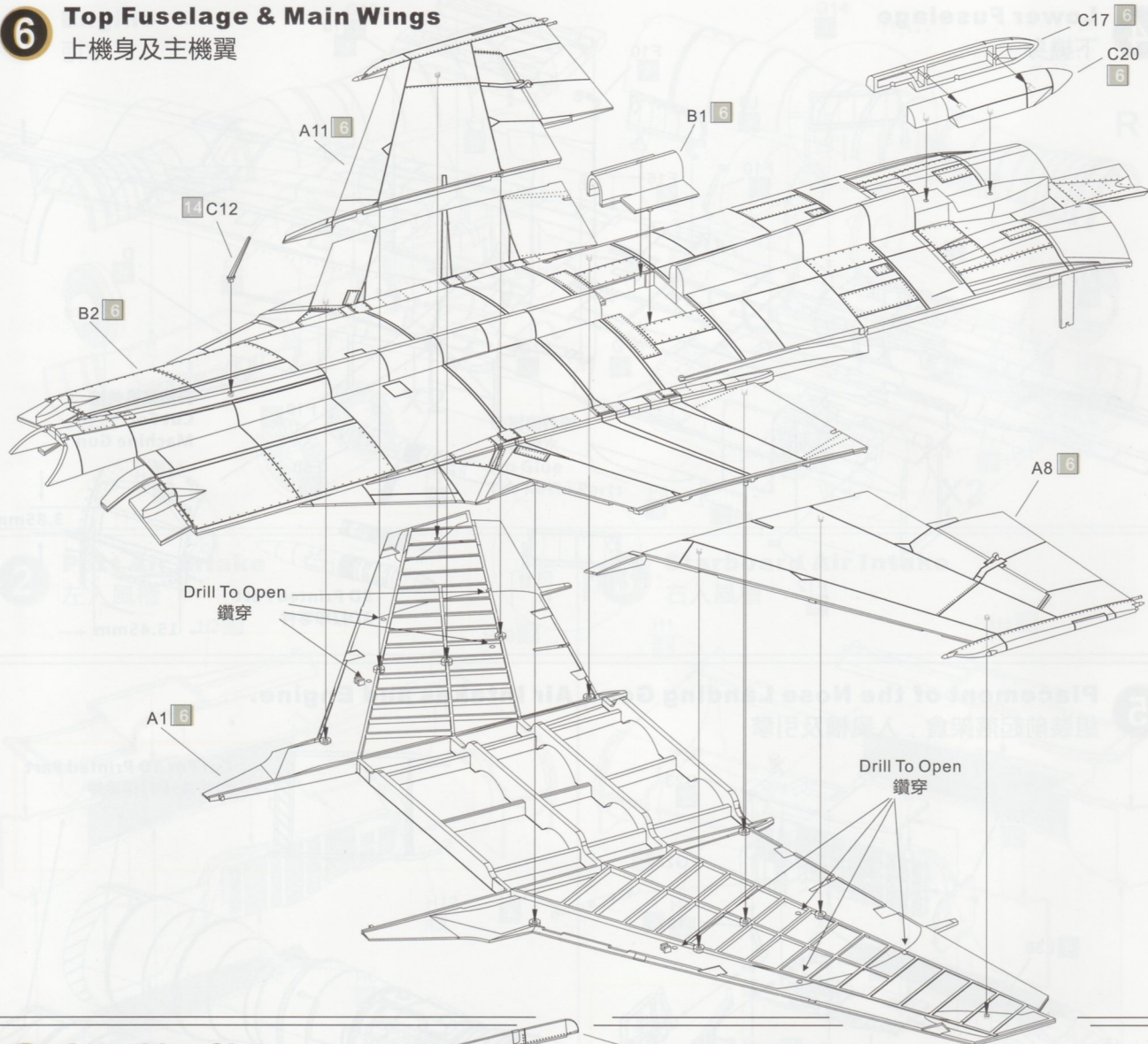

## 7 Attaching Slats

安裝前沿縫翼

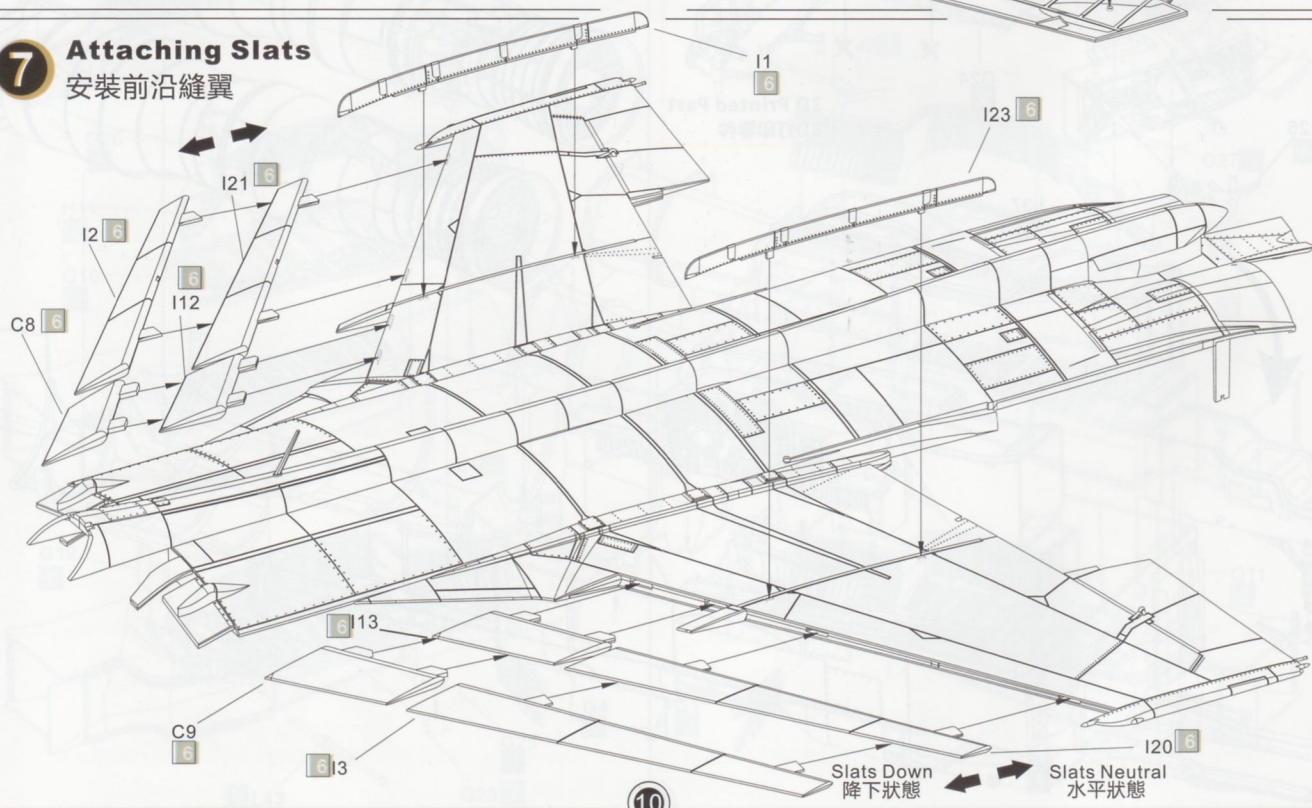

## 8 Attaching Flaps

安裝後縫翼

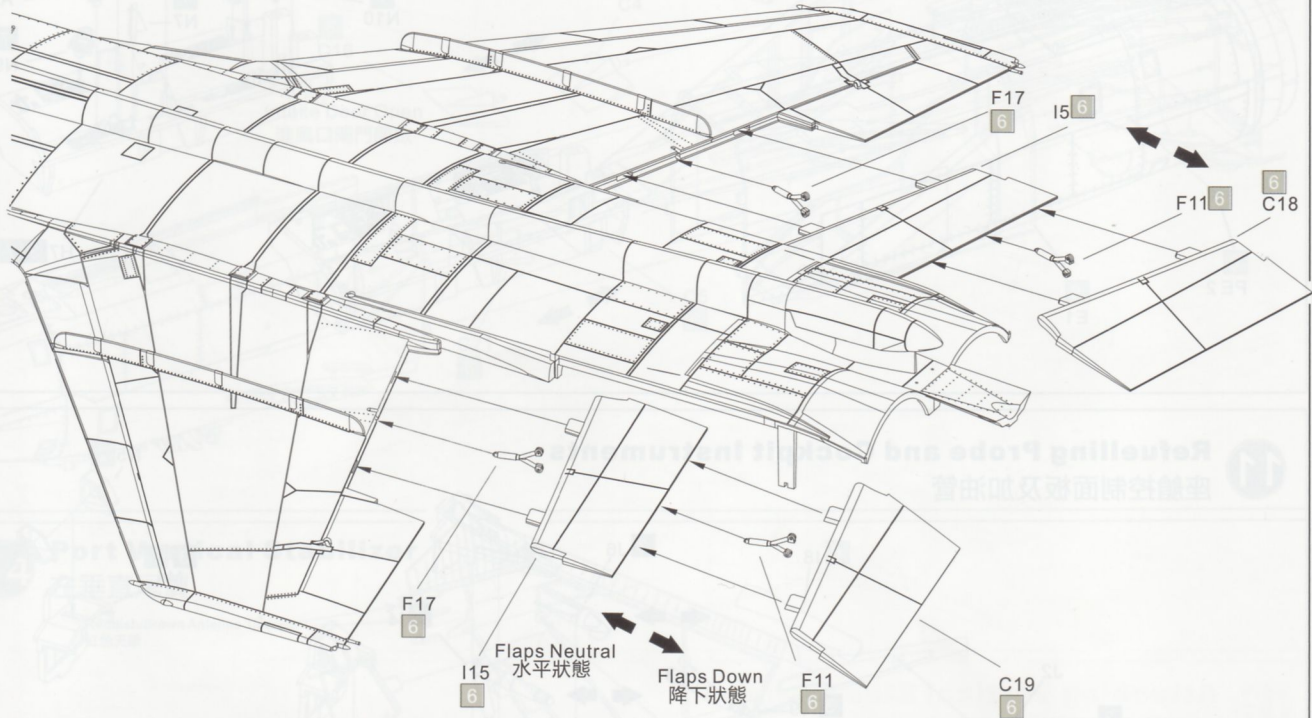

## 9 Fuselage Closure

組合上下機身

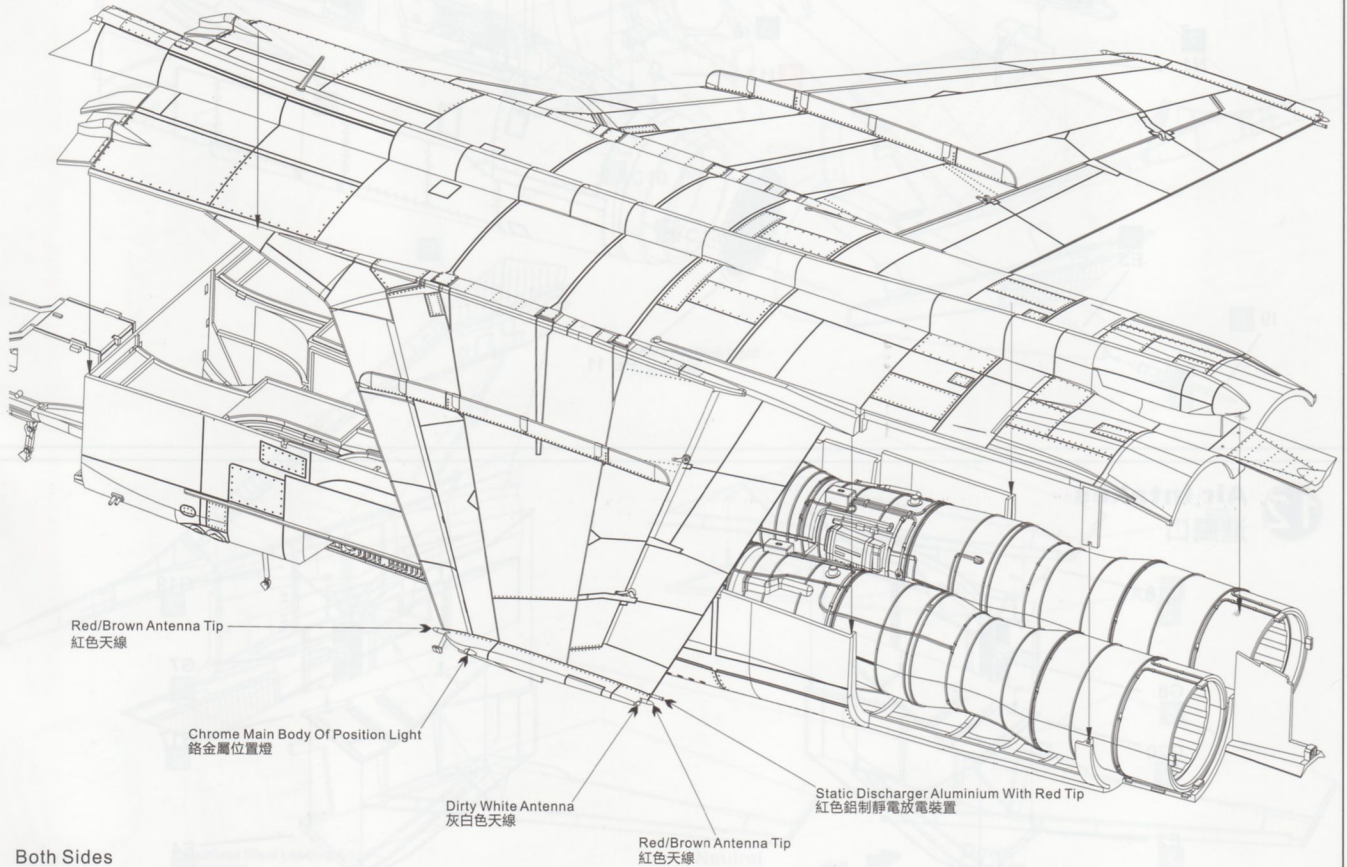



### 13 Fitting Nose Section and Intakes

組裝機頭及進風口

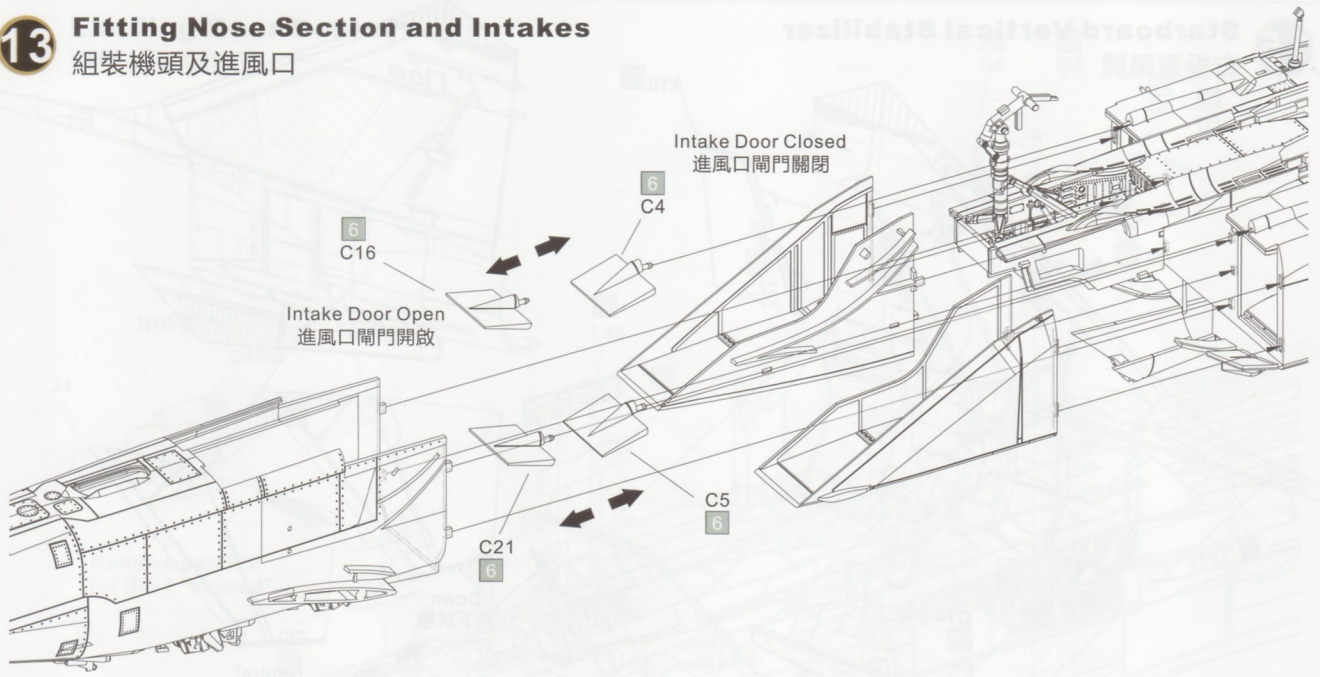

### 14 Port Vertical Stabilizer

左垂直尾翼

Reddish/Brown Antenna Tips  
紅色天線

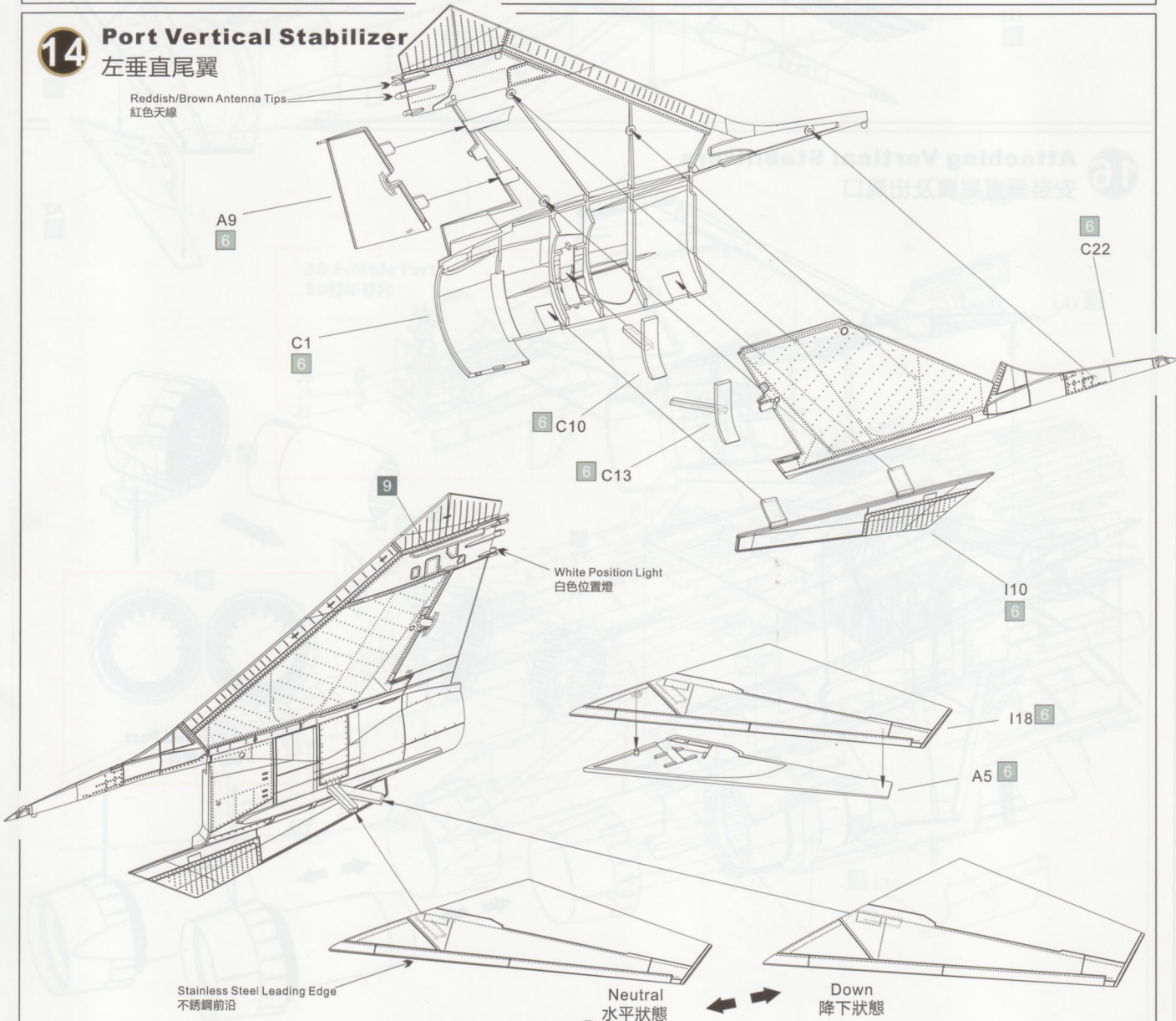

# 15 Starboard Vertical Stabilizer

右垂直尾翼

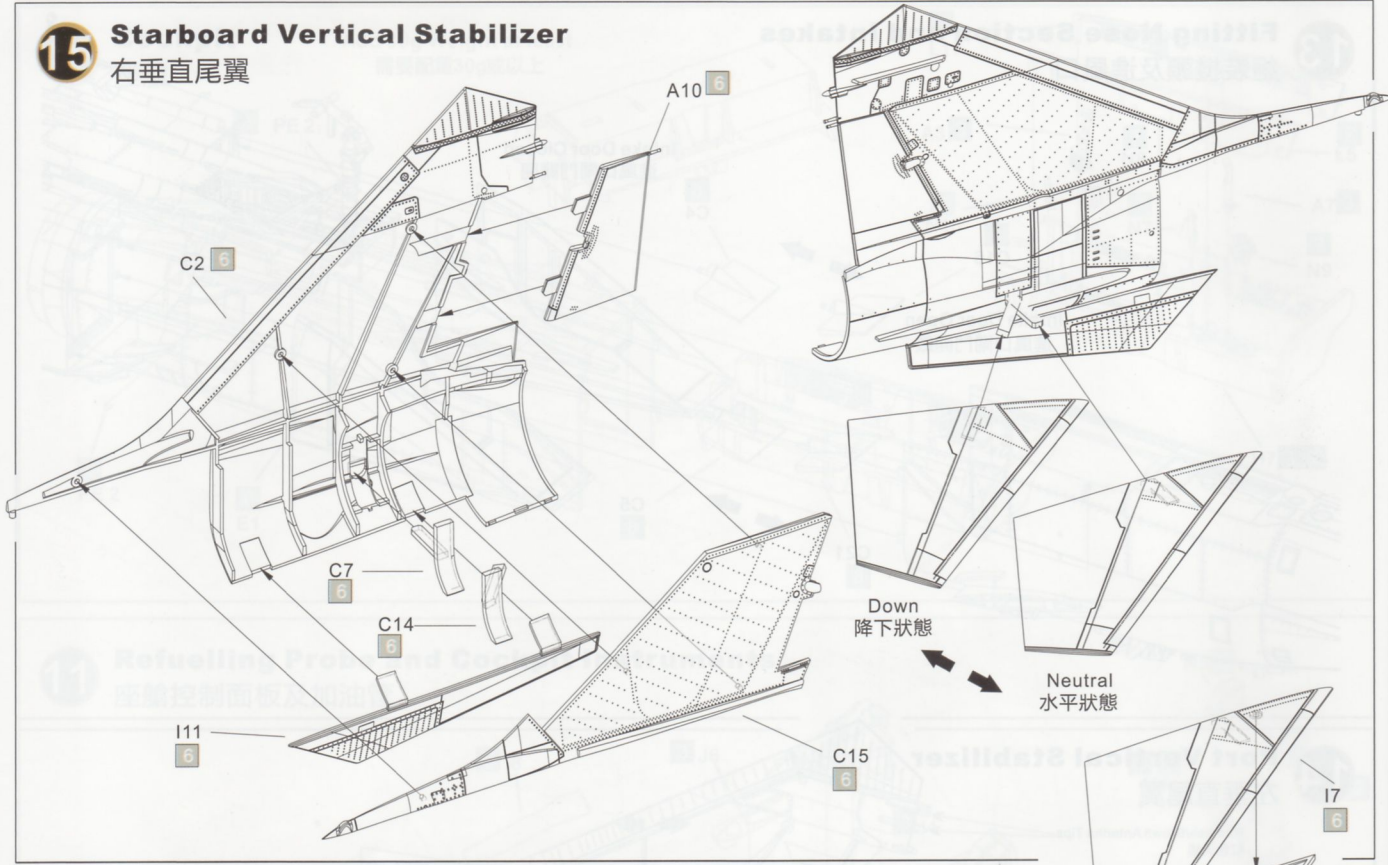

# 16 Attaching Vertical Stabilizers

安裝垂直尾翼及出風口

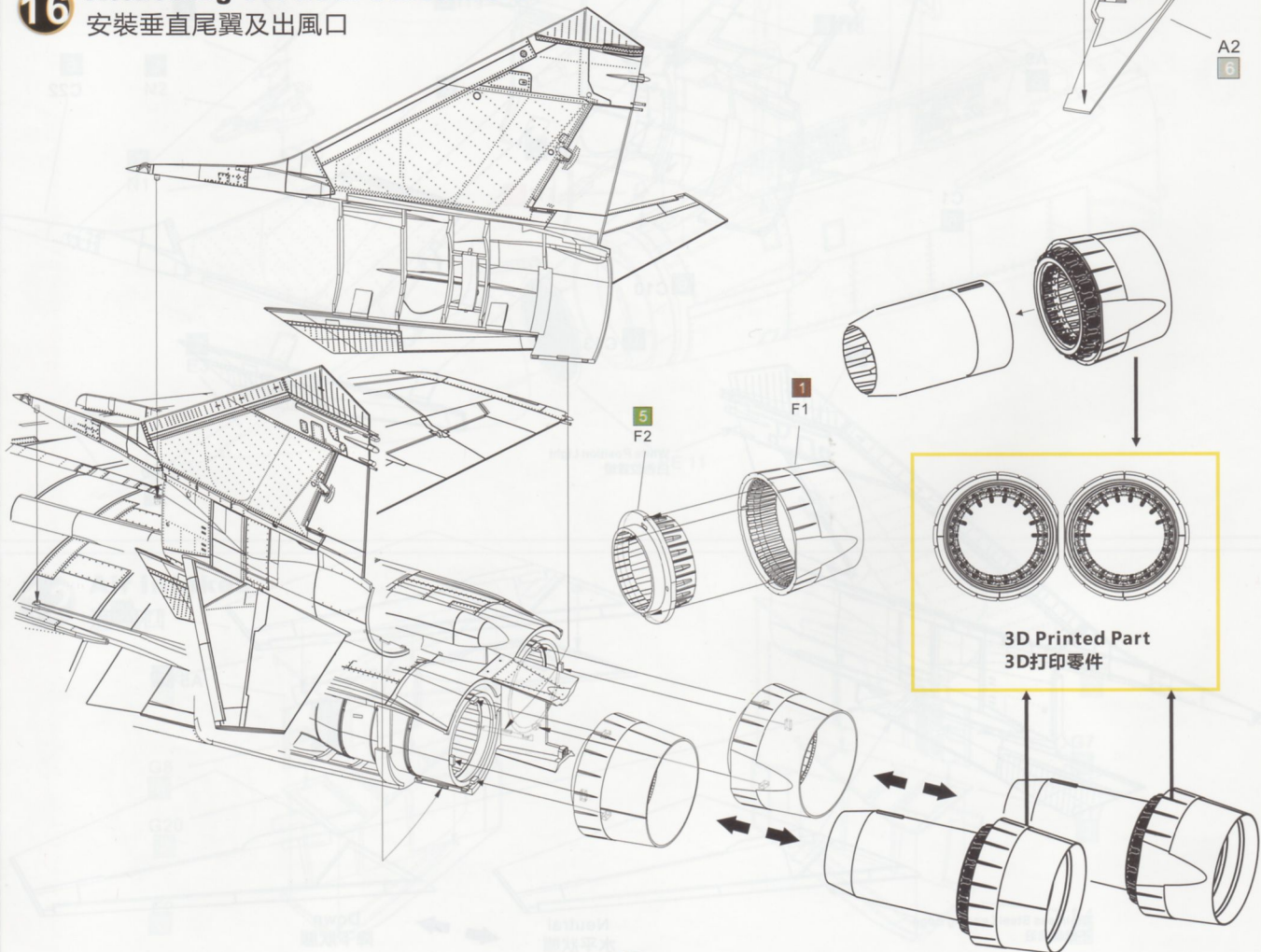

# 17 Landing Gear Doors.

安裝起落架艙蓋

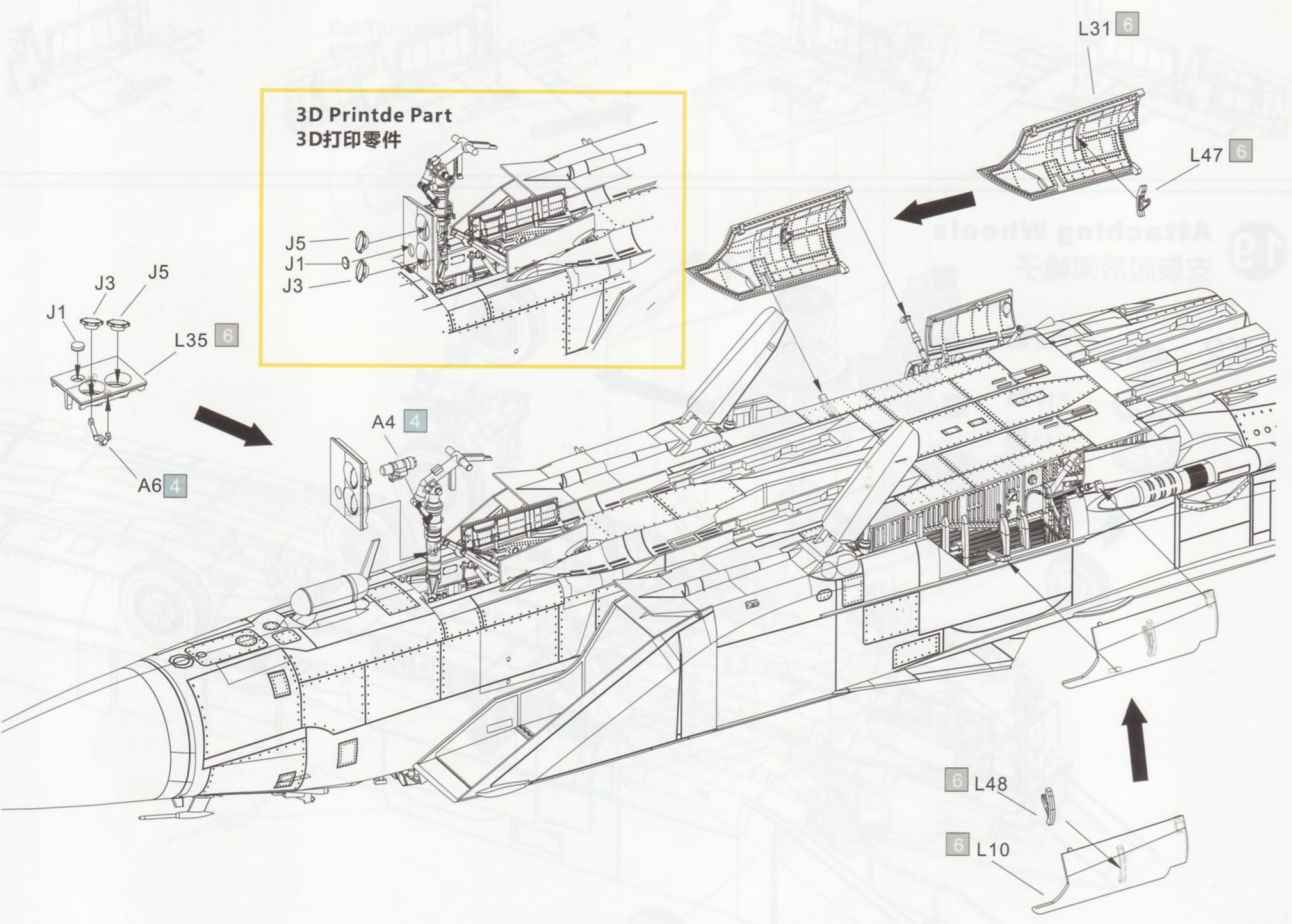
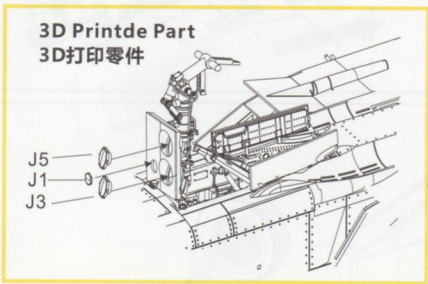
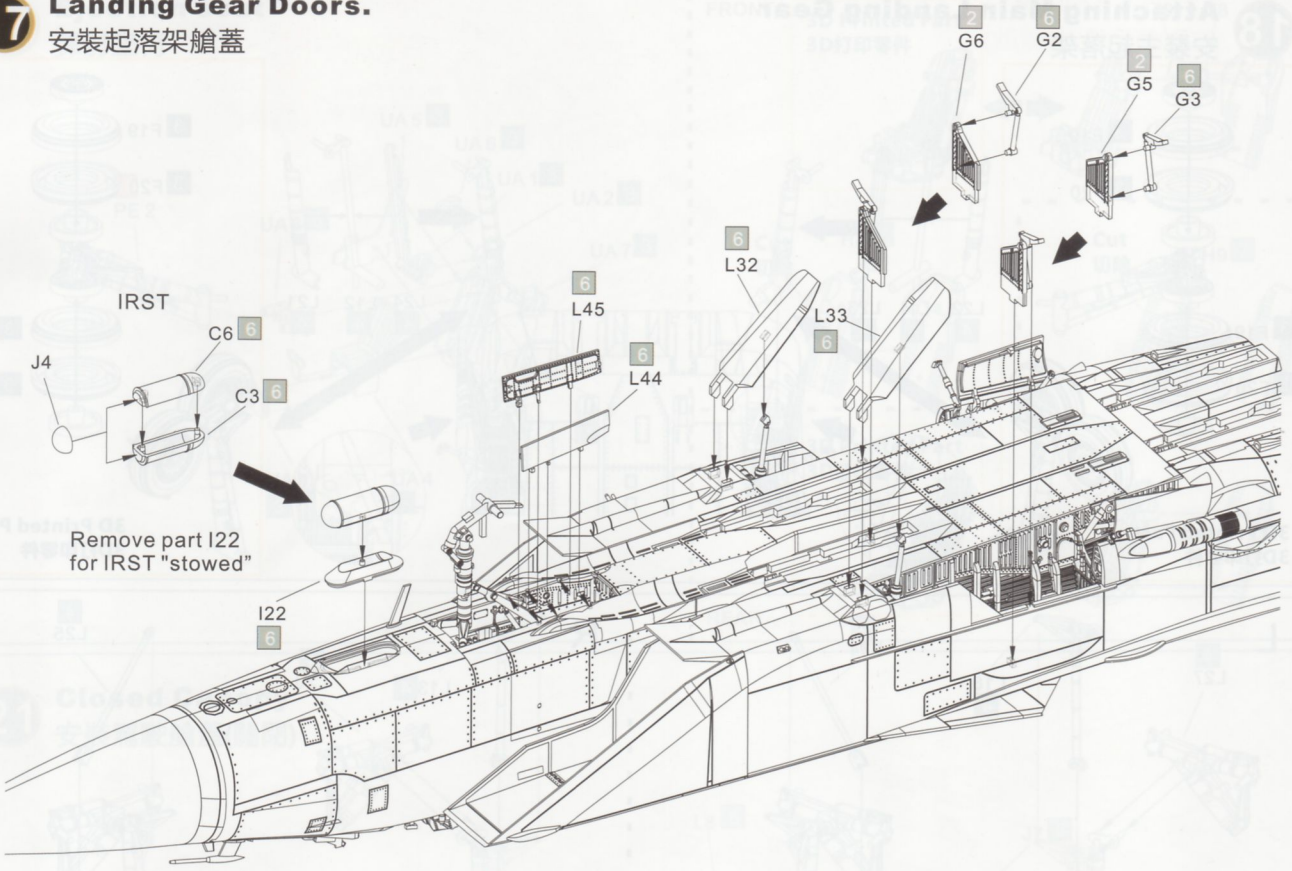

## 18 Attaching Main Landing Gear

安裝主起落架

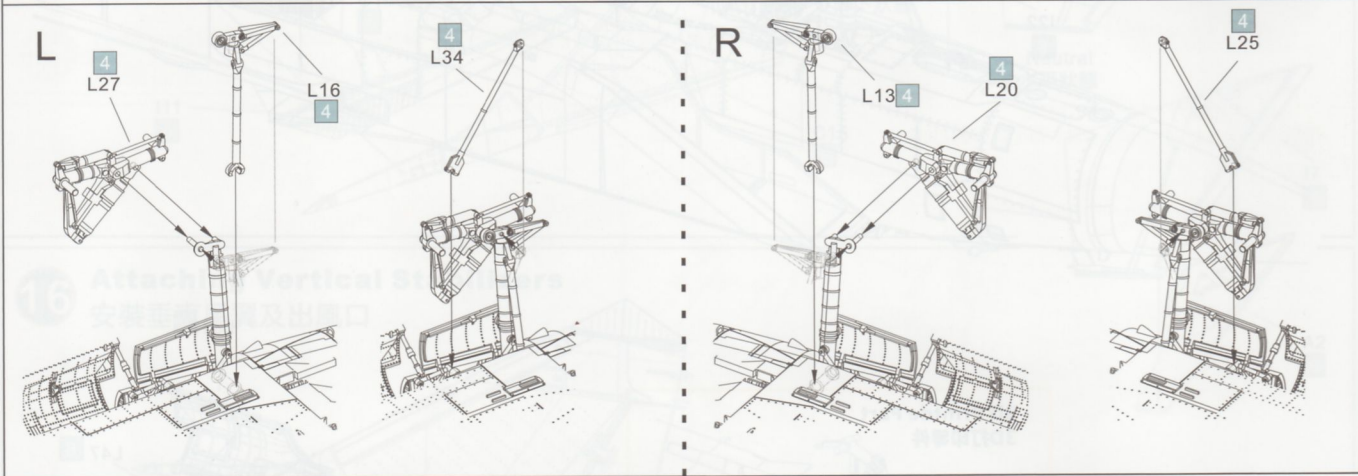
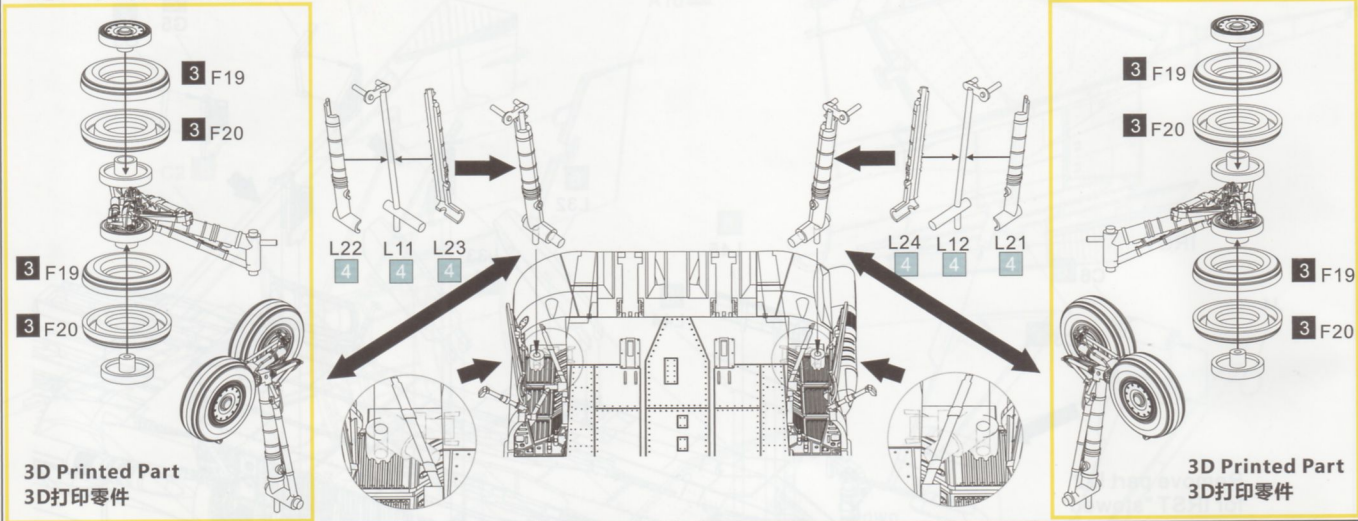

## 19 Attaching Wheels

安裝起落架輪子

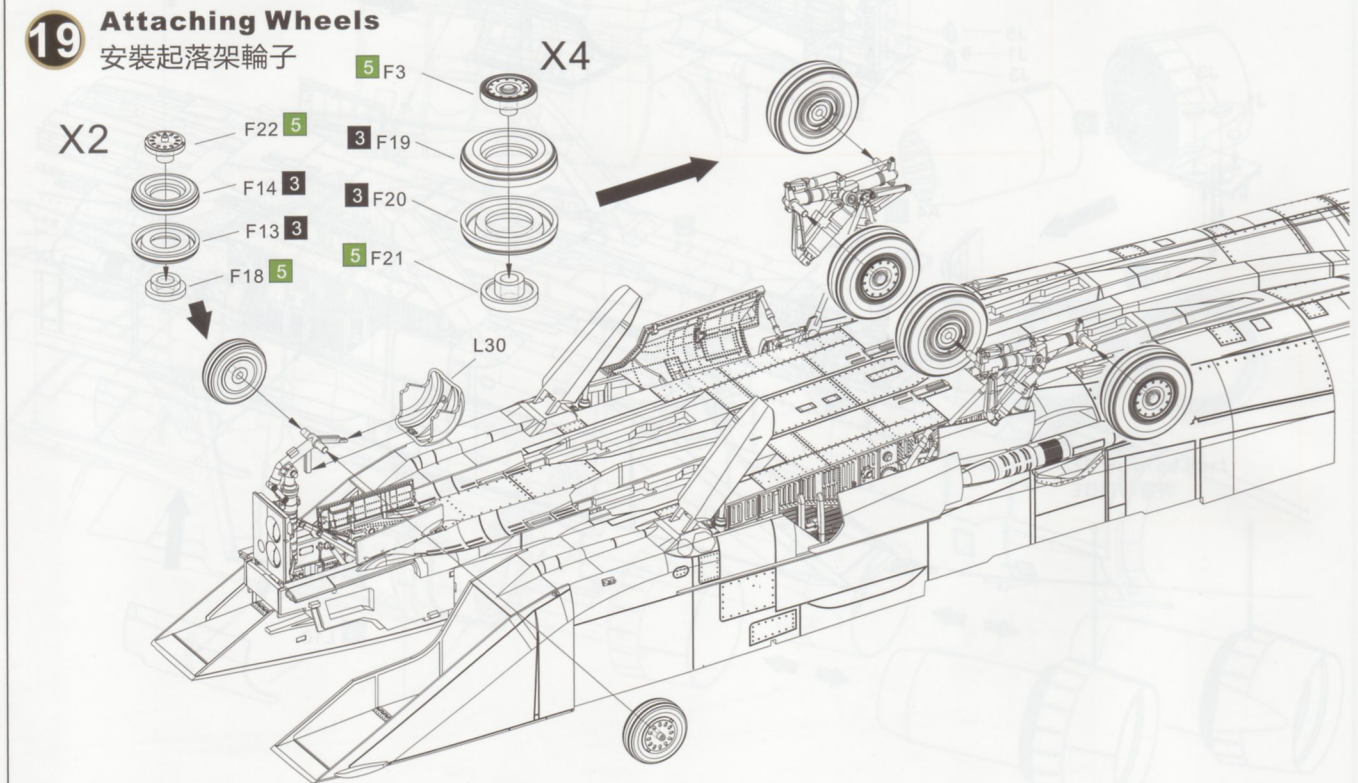



## 20 Ejection seat 彈射座椅

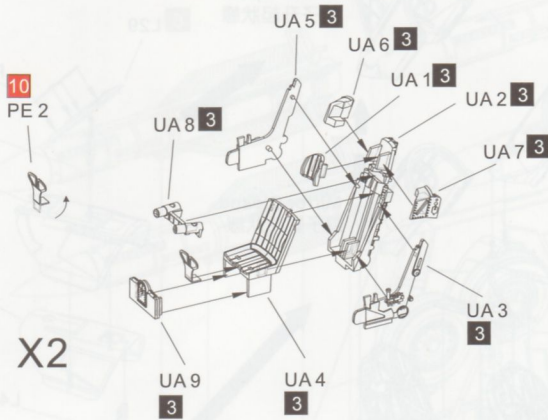

FRONT

3D Printed Part  
3D打印零件

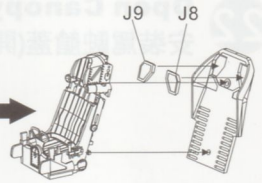
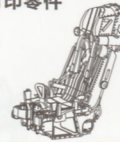

Cut  
切除

H8 7

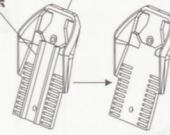

Cut  
切除

H9 7

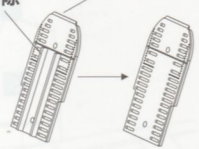

3D Printed Part  
3D打印零件

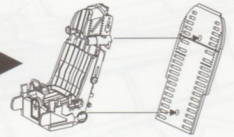
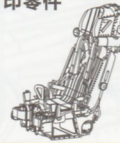

REAR

## 21 Closed Canopy 安裝駕駛艙蓋(關閉)

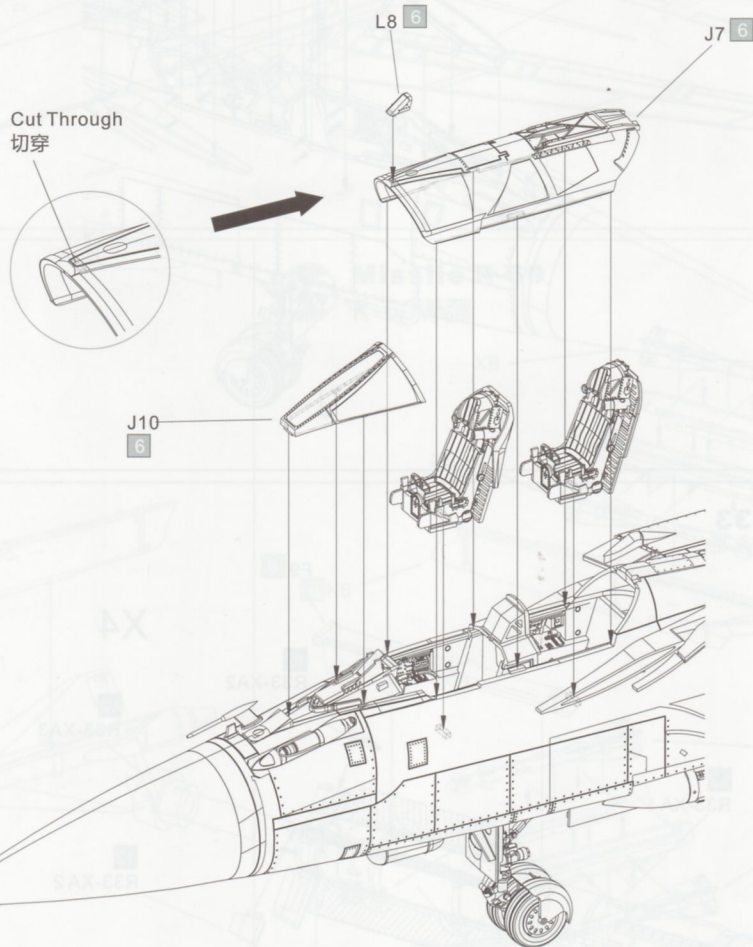

## 22 Open Canopy 安裝駕駛艙蓋(開啟)

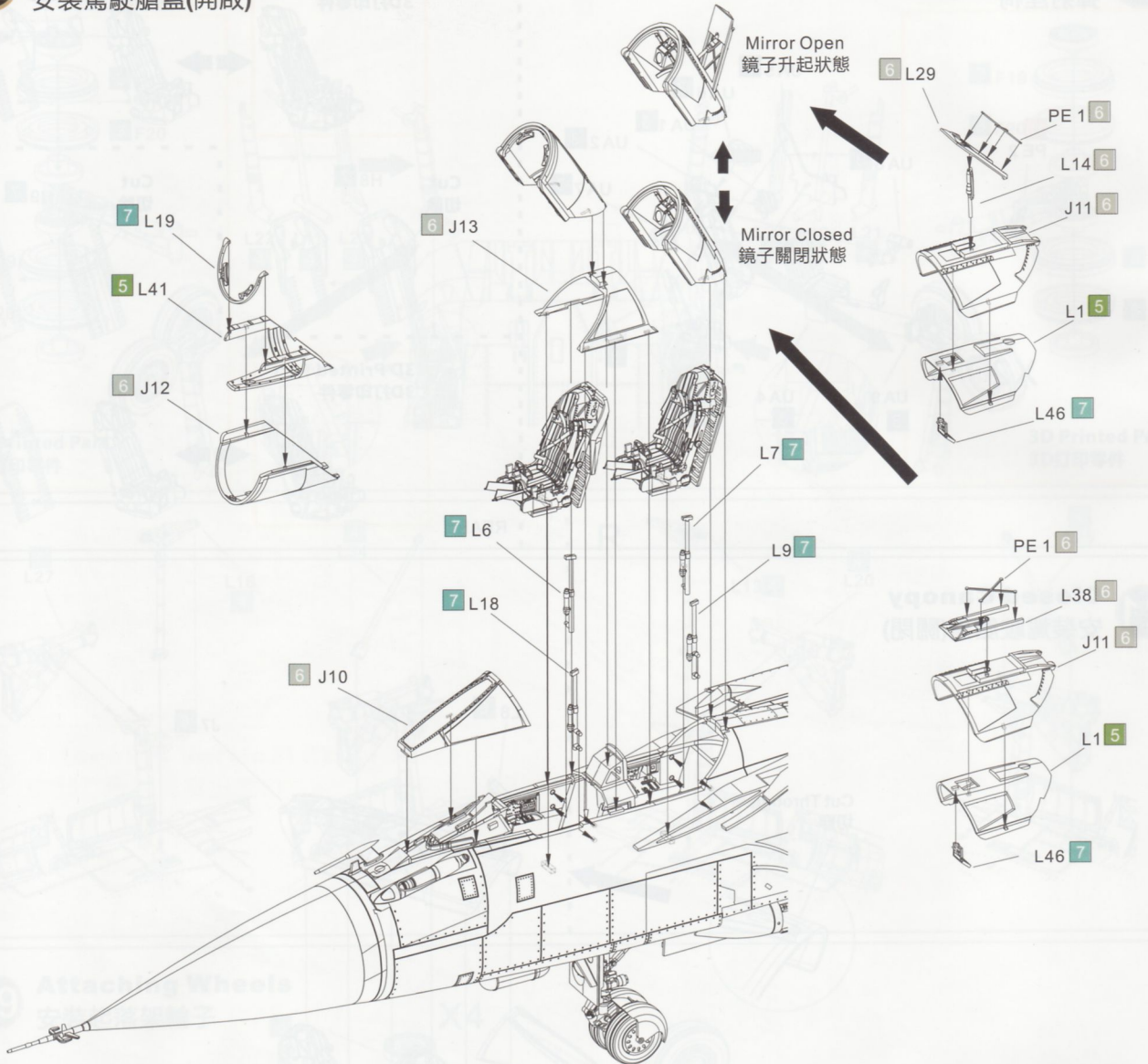

## 23 Missile R-33 R-33導彈

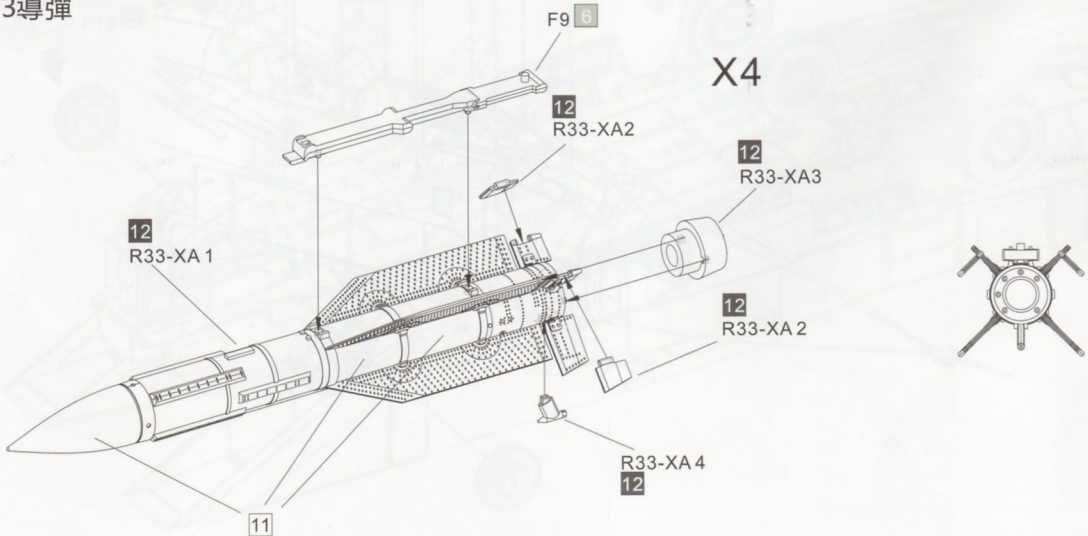

**24** Attaching R-33  
安裝 R-33導彈

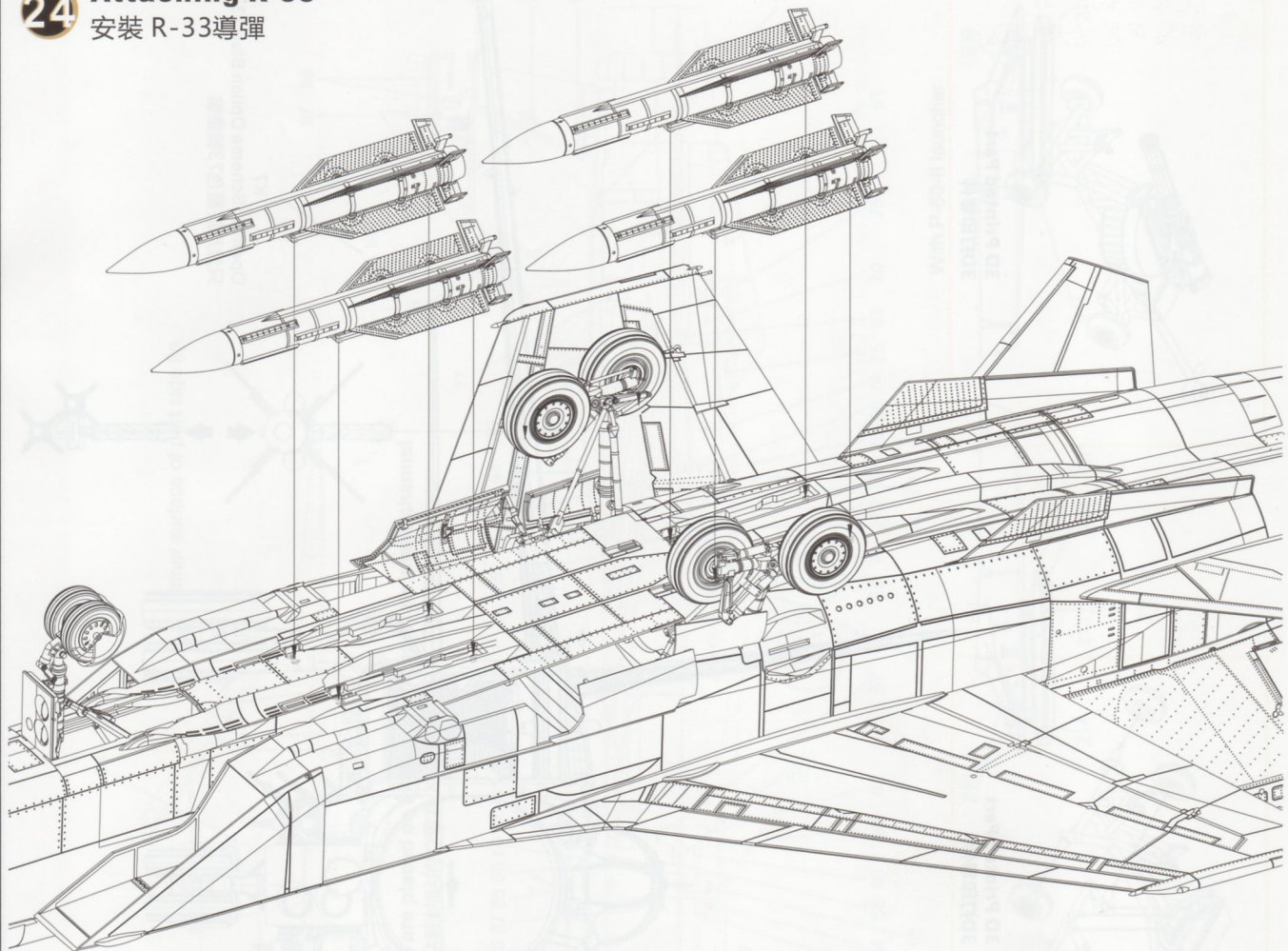

**25** Missile R-40  
R-40導彈

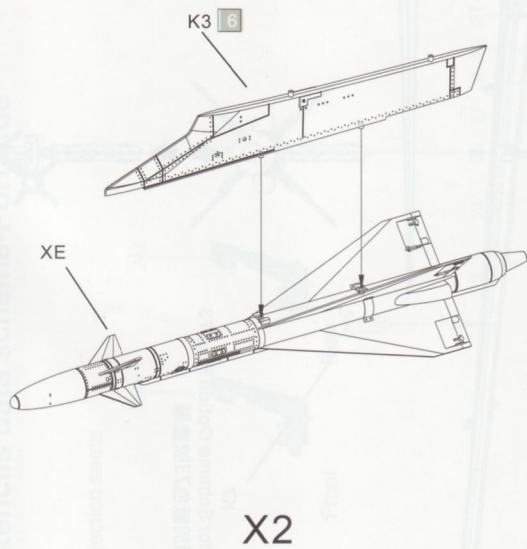

**26** Missile R-60  
R-60導彈

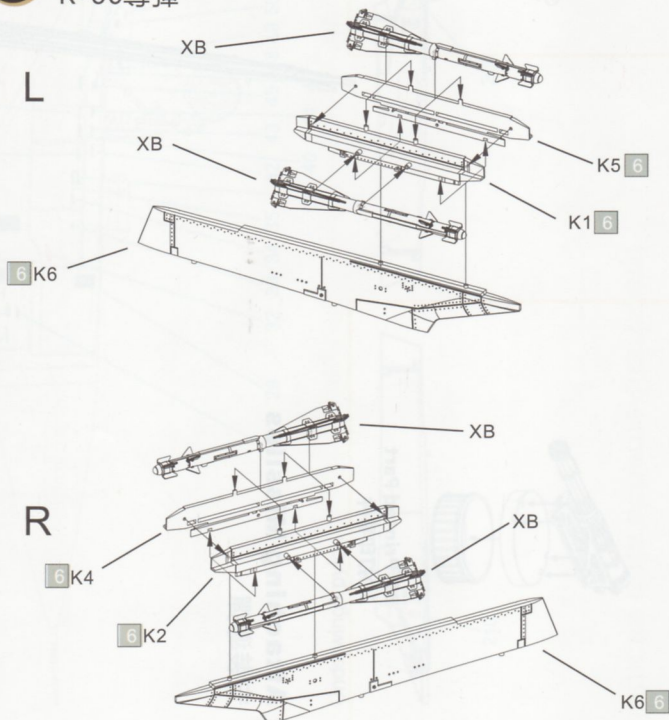

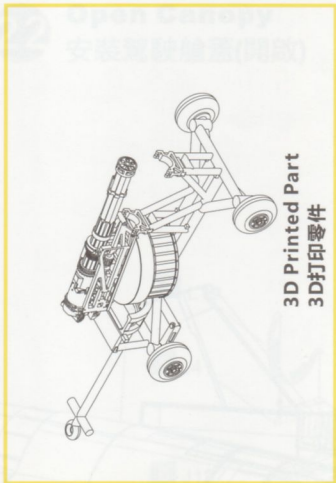

3D Printed Part  
3D打印零件

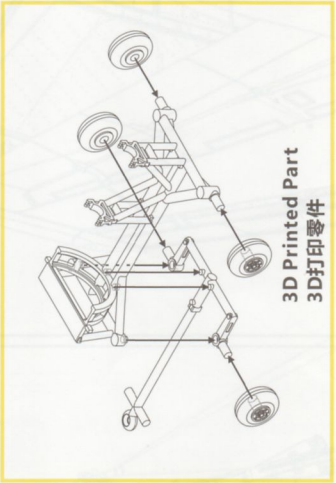

3D Printed Part  
3D打印零件

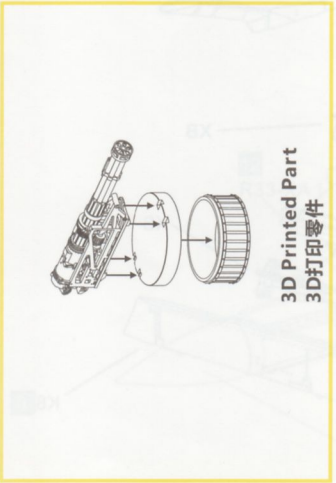

3D Printed Part  
3D打印零件

**27** Attaching Missiles  
安裝導彈

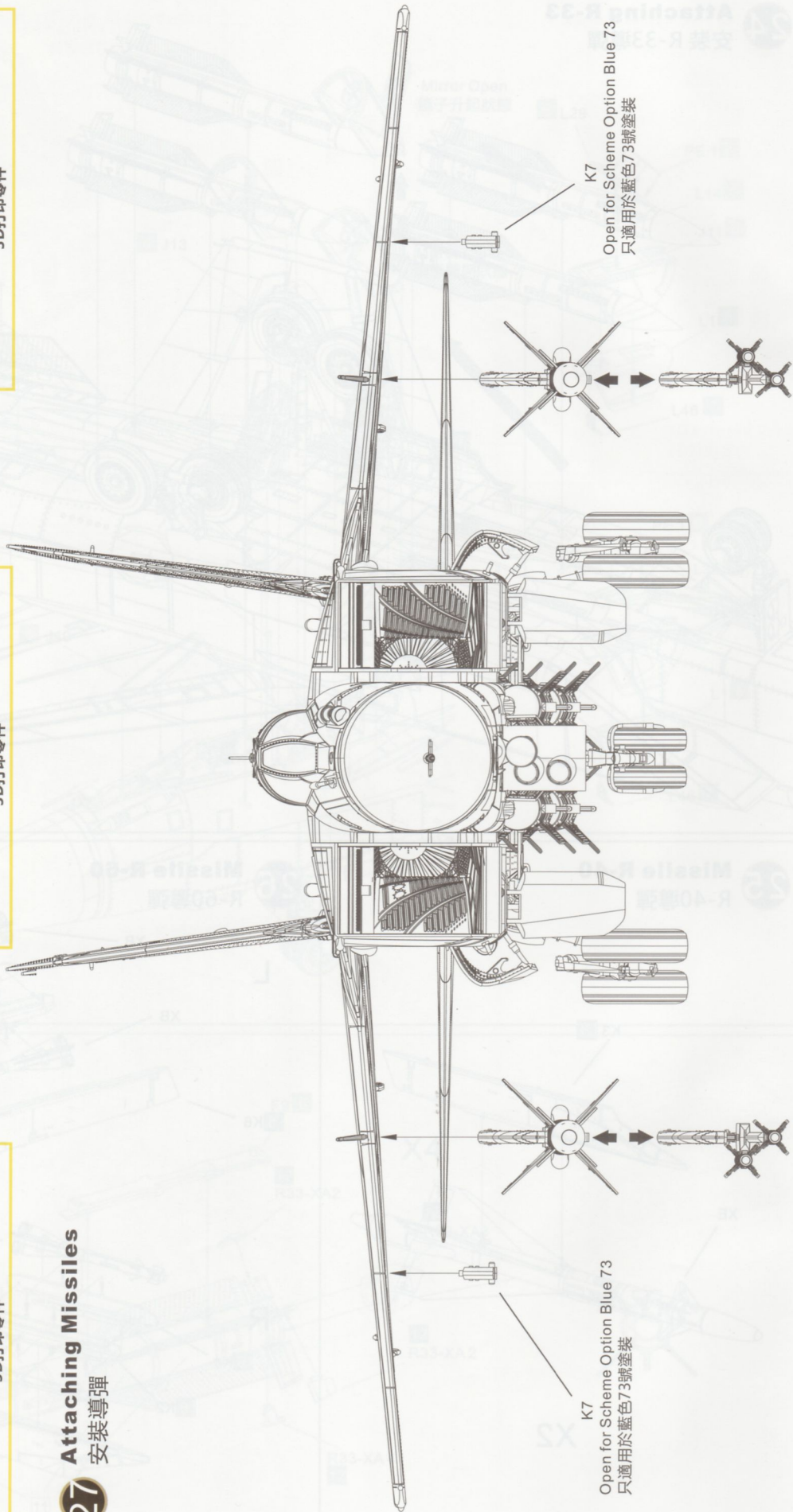

# Stencils data scheme-Port side

Ejection seats

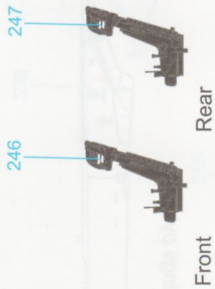

Front

Rear

Inner surface of port side fin

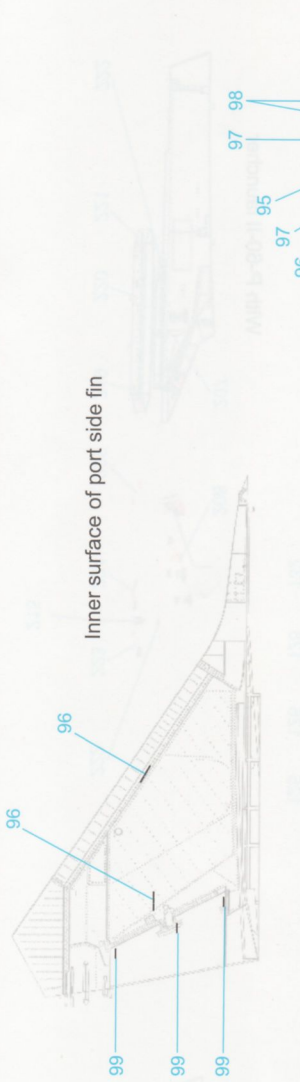

!!! 53\* - Decals No.53 are placed on internal surfaces of air intake channel  
 !!! 53\* 注意, 53號水貼粘貼的位置為入風口內側。

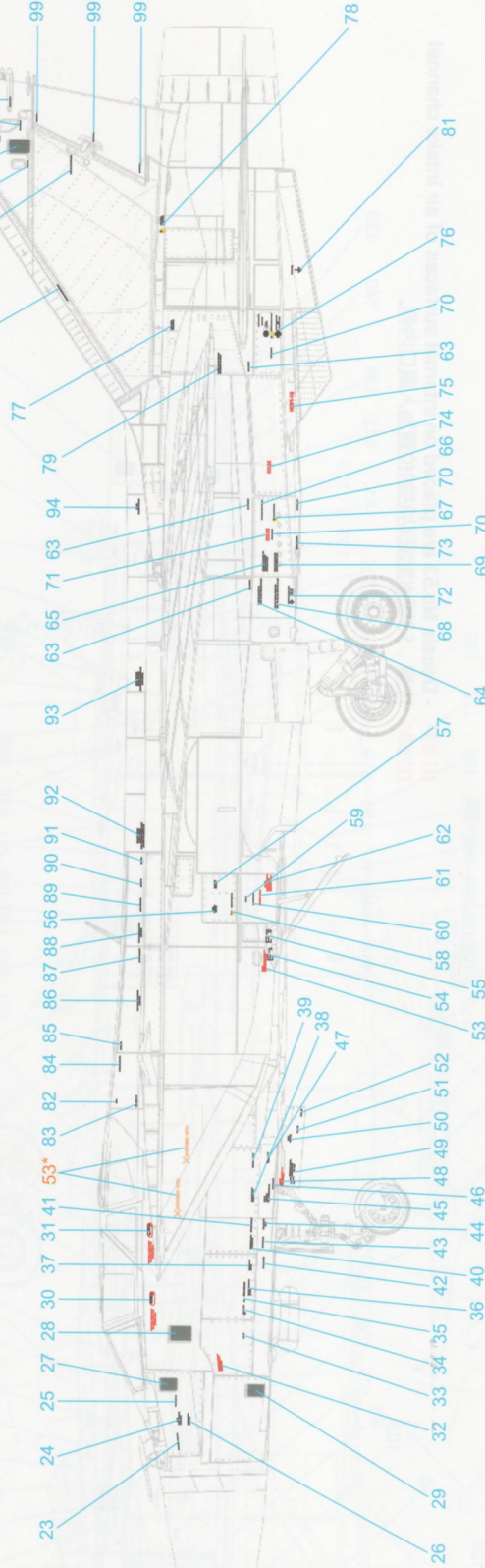

Underwings pylon



With P-60-II launcher

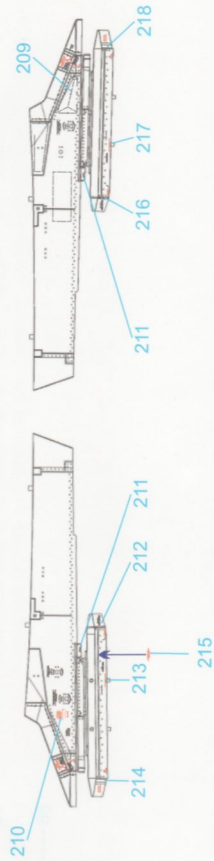



# Stencils data scheme-Top

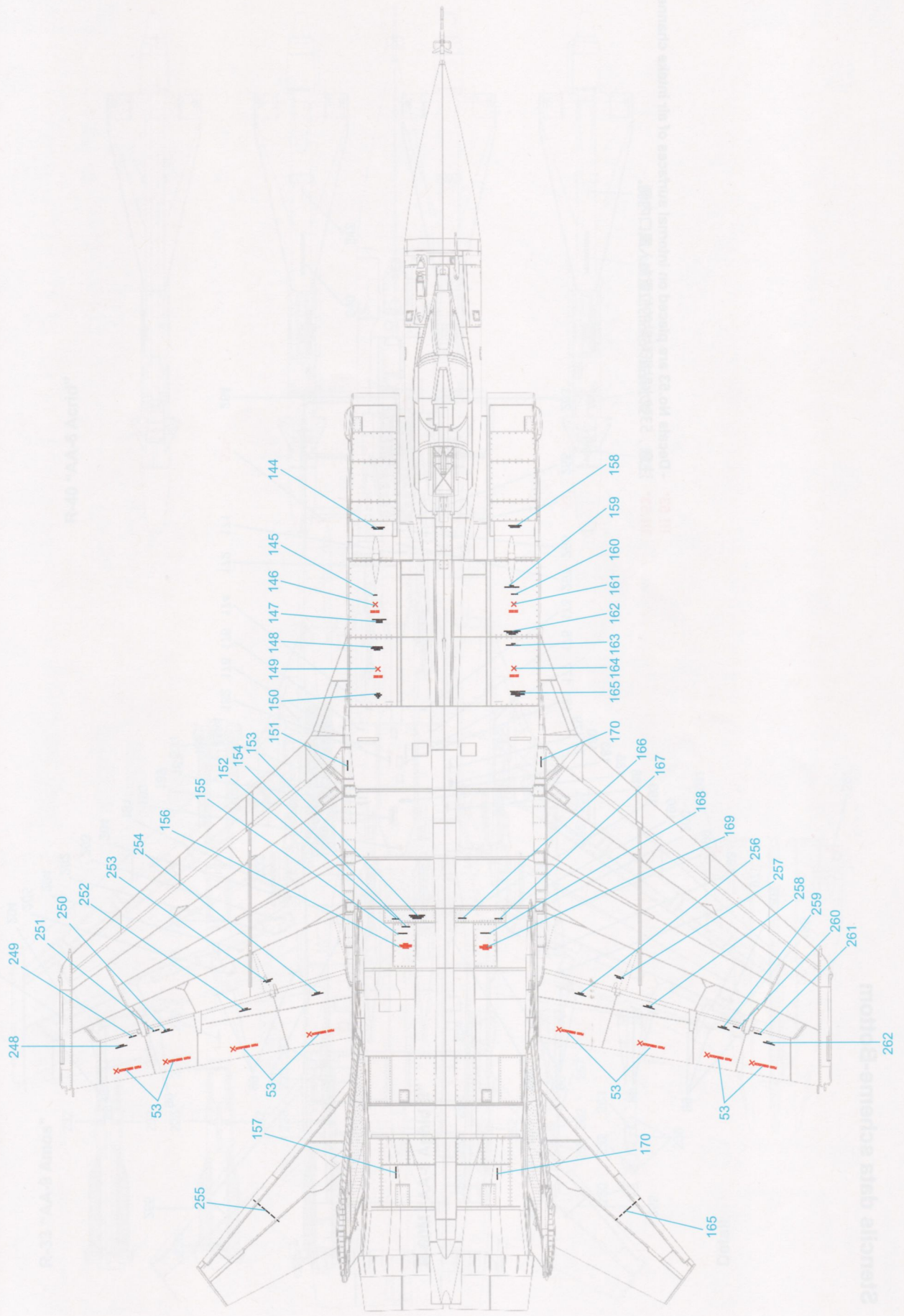

Stencils data scheme-Bottom

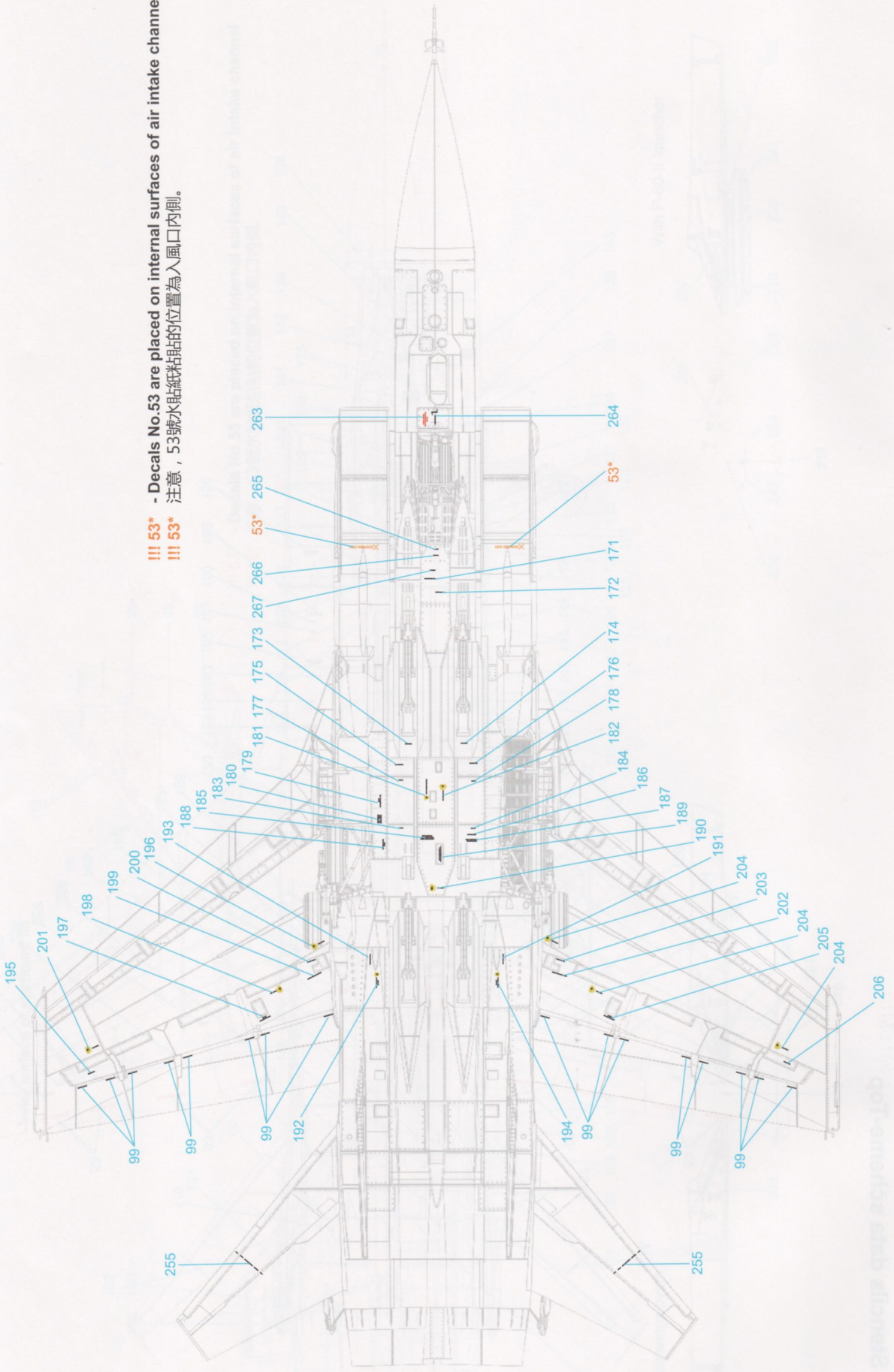

!!! 53\* - Decals No.53 are placed on internal surfaces of air intake channel  
 !!! 53\* 注意, 53號水貼紙貼的位置為入風口內側。



Stencils data scheme-Missiles

R-33 "AA-9 Amos"

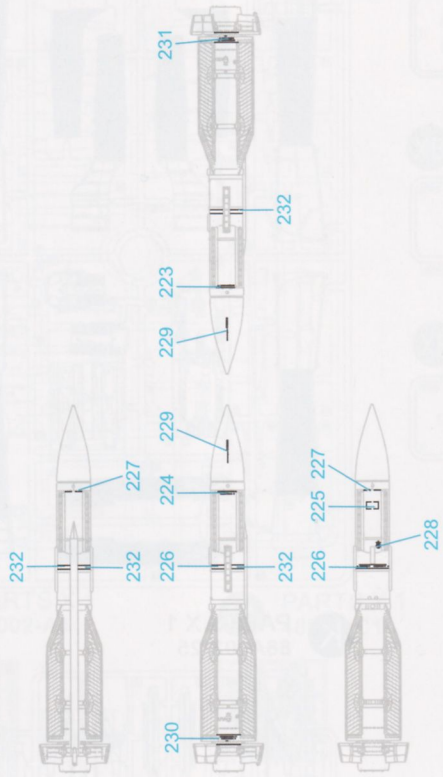

R-40 "AA-6 Acrid"

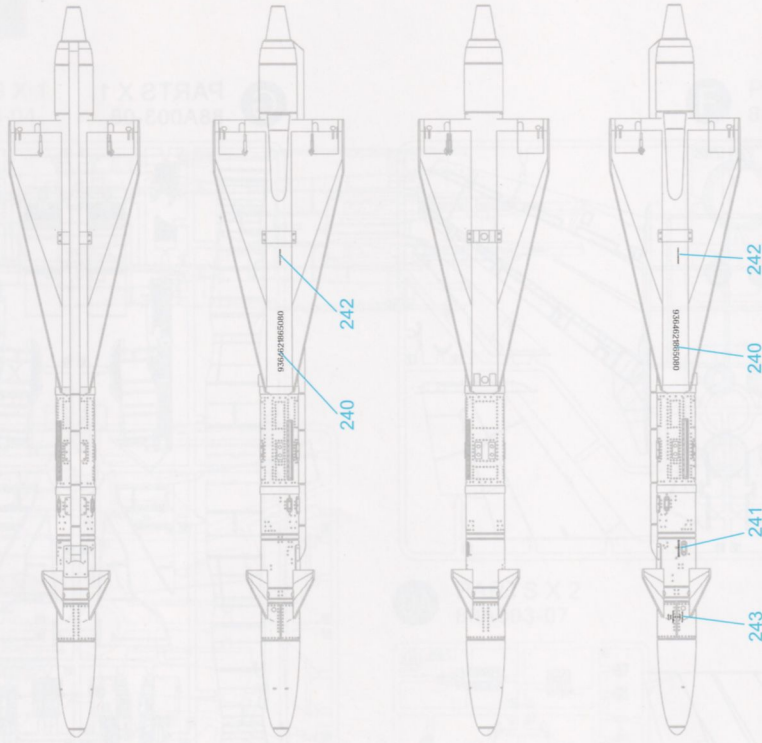

R-60M "AA-8 Aphid B"

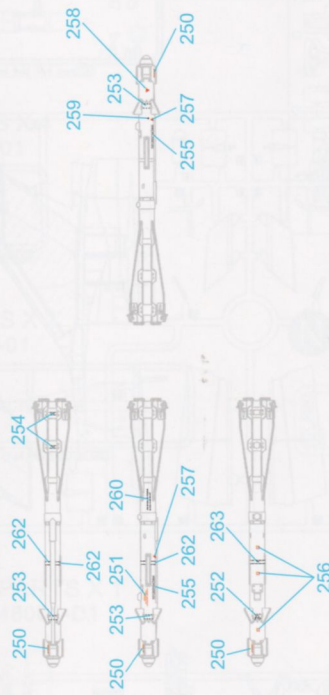

Detail

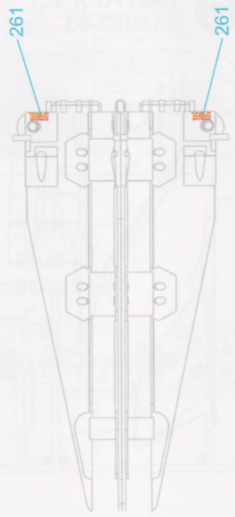

# PARTS

**A** PARTS X 1  
88A003-01

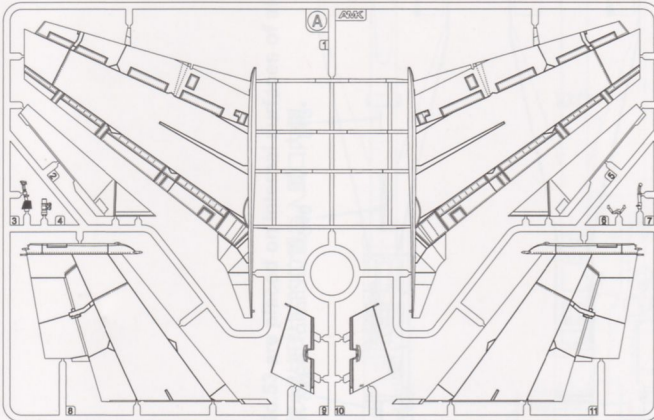

**B** PARTS X 1  
88A003-02

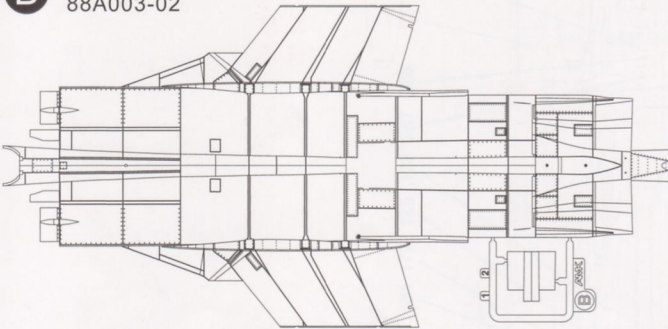

**C** PARTS X 1  
88A003-03

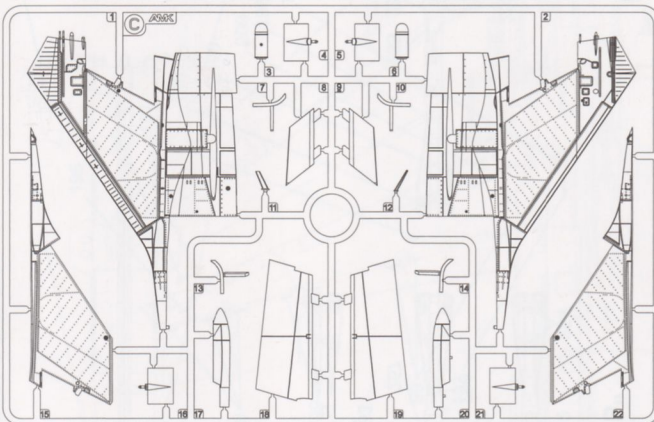

**E** PARTS X 1  
88A003-05

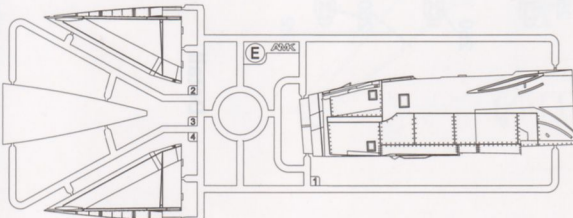

**G** PARTS X 1  
88A003-08

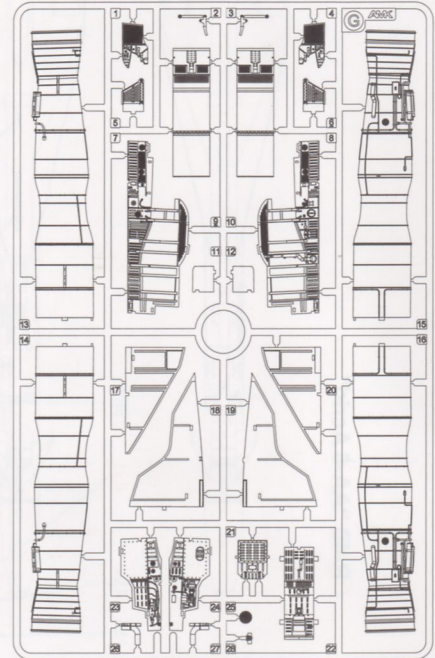

**H** PARTS X 1  
88A003-09

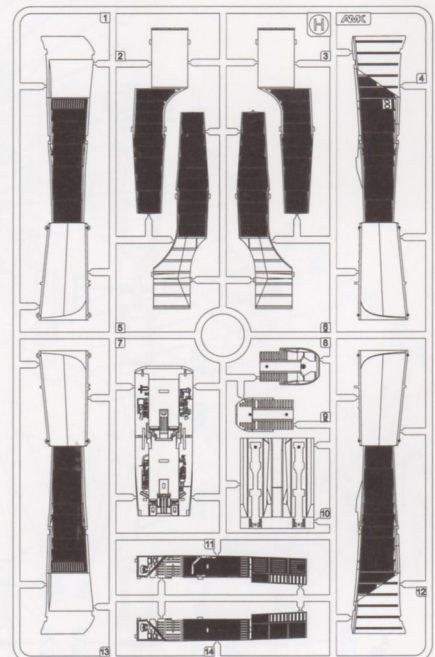

**K** PARTS X 1  
88A003-25

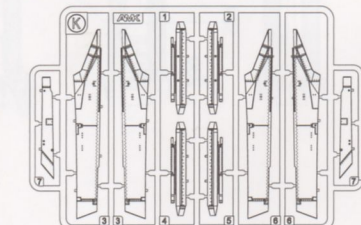

# PARTS

**D** PARTS X 1  
88A003-04

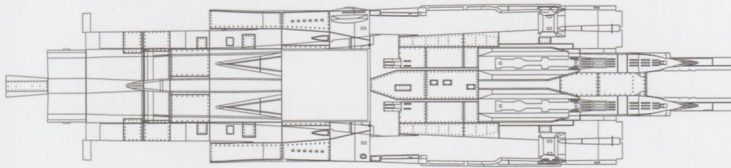

**I** PARTS X 1  
88A003-10

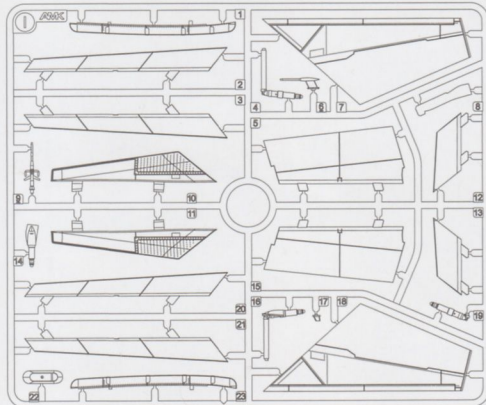

**L** PARTS X 1  
88A003-13

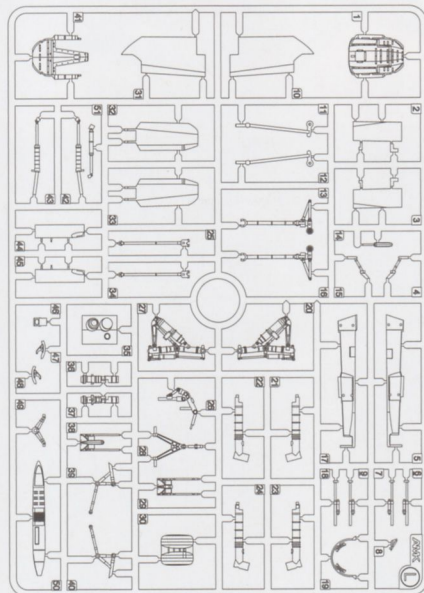

**F** PARTS X 2  
88A003-06

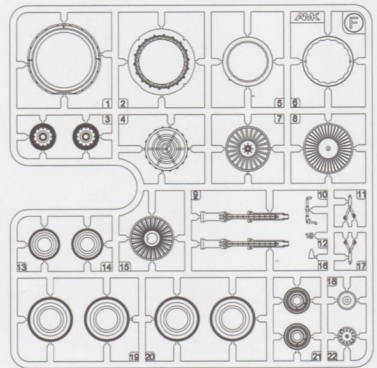

**UA** PARTS X 2  
88A003-07

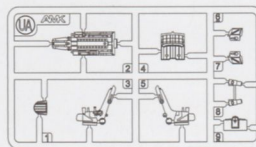

**J** PARTS X 2  
88A003-11

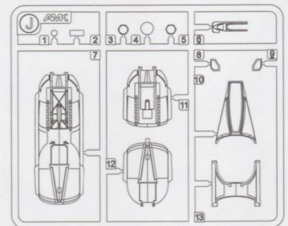

**XA** PARTS X 4  
99001-01

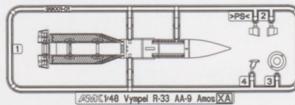

**XB** PARTS X 4  
99005-01

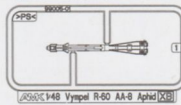

**XE** PARTS X 2  
99003-01

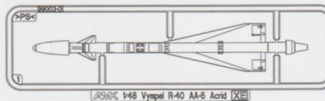

**PE** PARTS X 1  
88A003-27

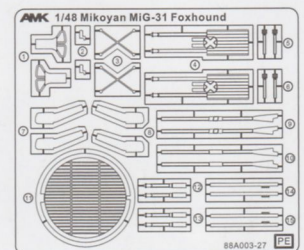

**N** PARTS X 1  
88A003-24

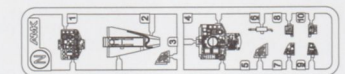

**A1** PARTS X 1  
48002-A1

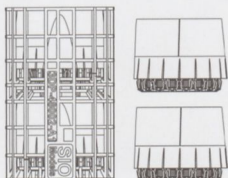

**C1** PARTS X 1  
48002-C1



**D1** PARTS X 1  
48002-D1

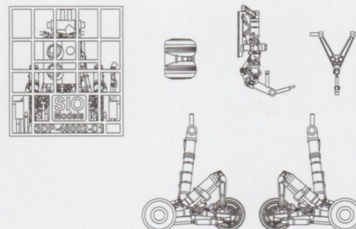

**E1** PARTS X 1  
48002-E1

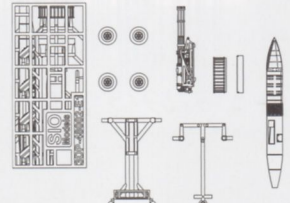

**SIO**  
Models



6 973975 350095

MADE IN CHINA

© Copyright 2020, SIO Models

MiG-31 B/BS  
Mikoyan Foxhound

**1/48 SCALE**

**K48002**