



MMK Folknáře 70 40501 Děčín [www.mmk.cz](http://www.mmk.cz) [mk.model@volny.cz](mailto:mk.model@volny.cz)

## 35070 T 813 KOLOS

● PUR PARTS ● PHOTO EDCHED PARTS ● NOT INCLUDED

4	NM-35	0987654321	VA 7 VA	500%	500%
3	NM-32	0987654321		500%	500%
2		0987654321	B	500%	500%
1		0987654321	B	500%	500%
		0987654321	10		
		0987654321			
		0987654321			

C1  
 C2  
 C3  
 C4

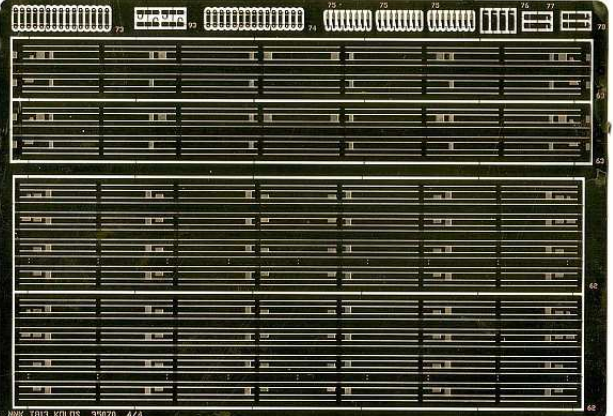
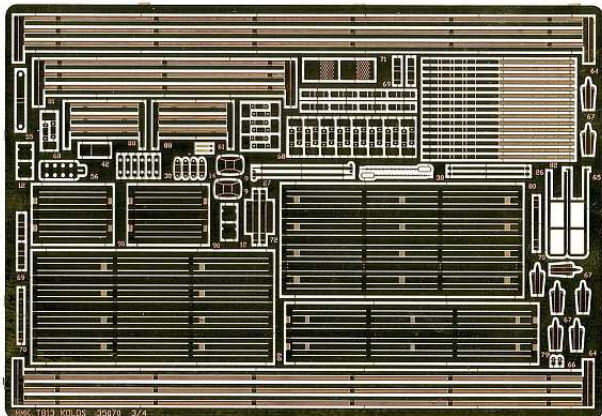
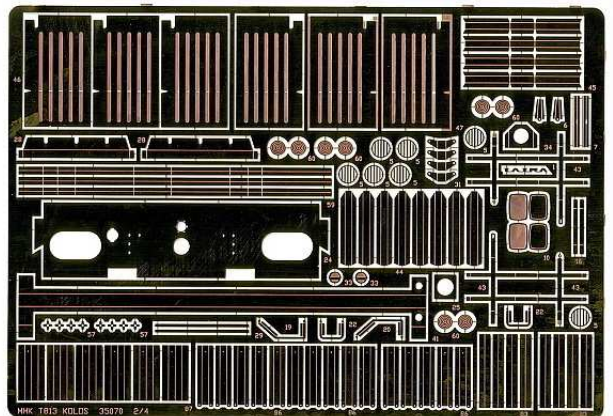
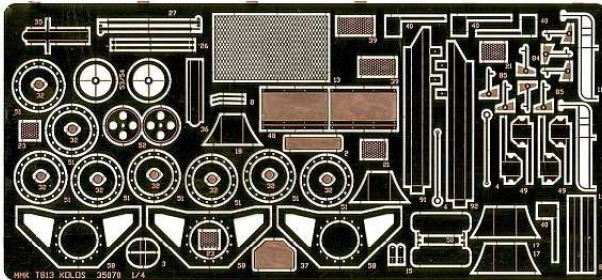

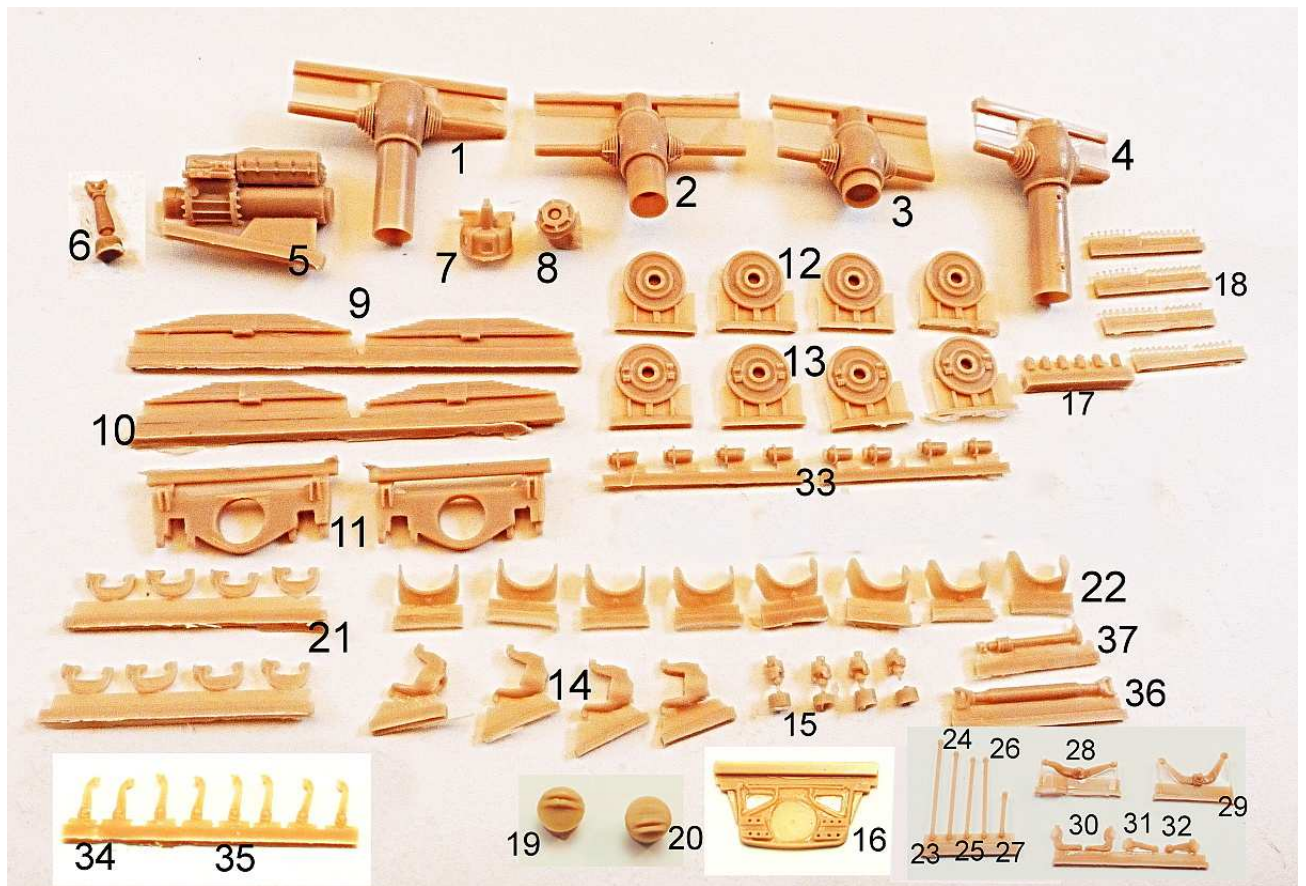

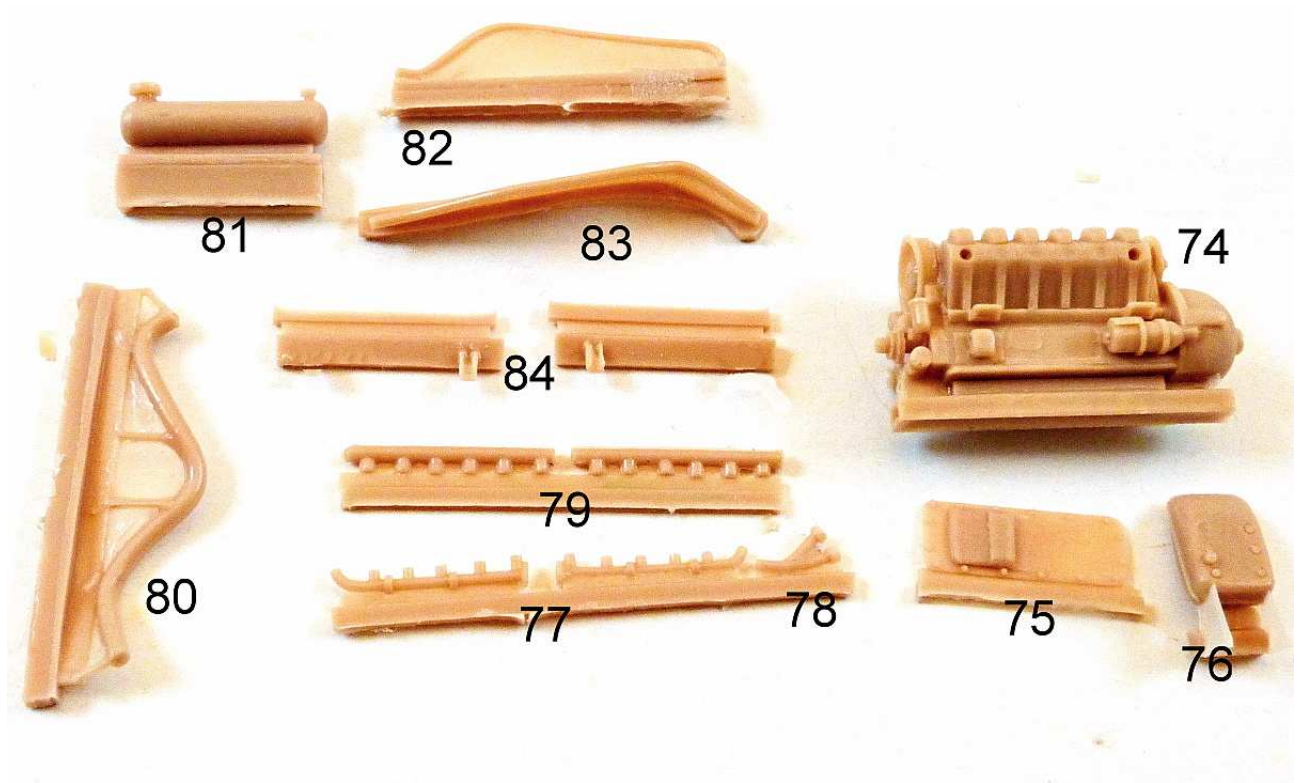

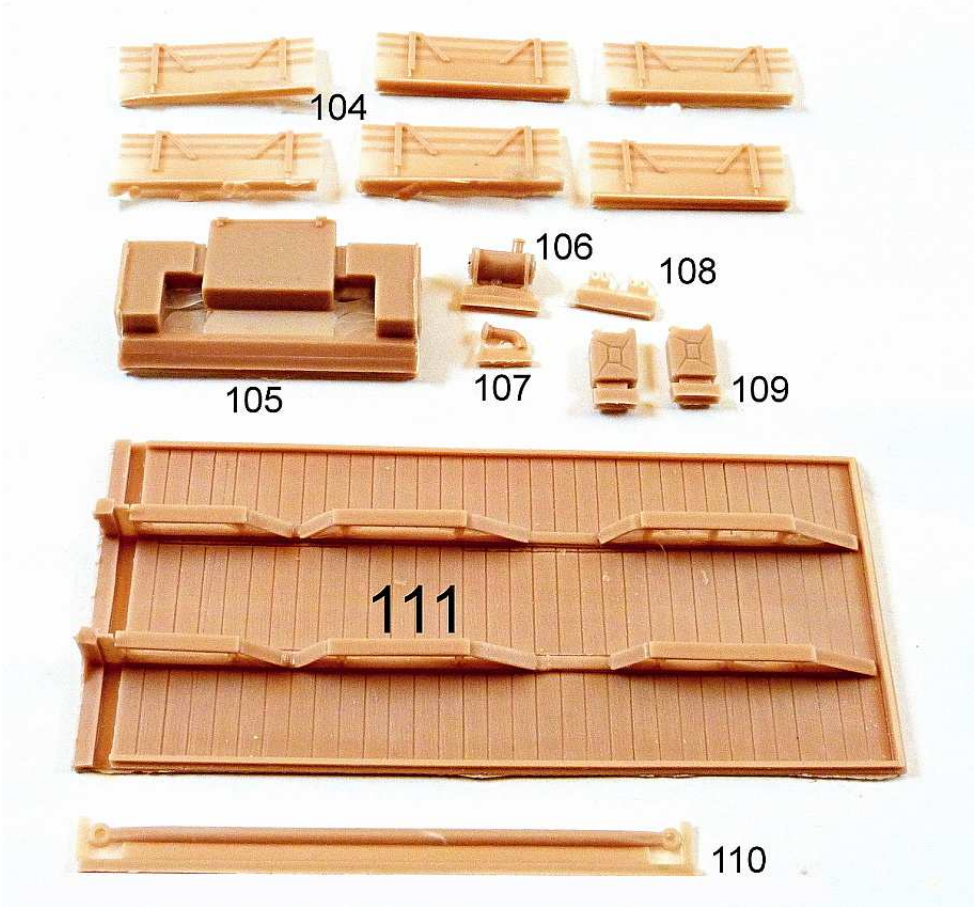
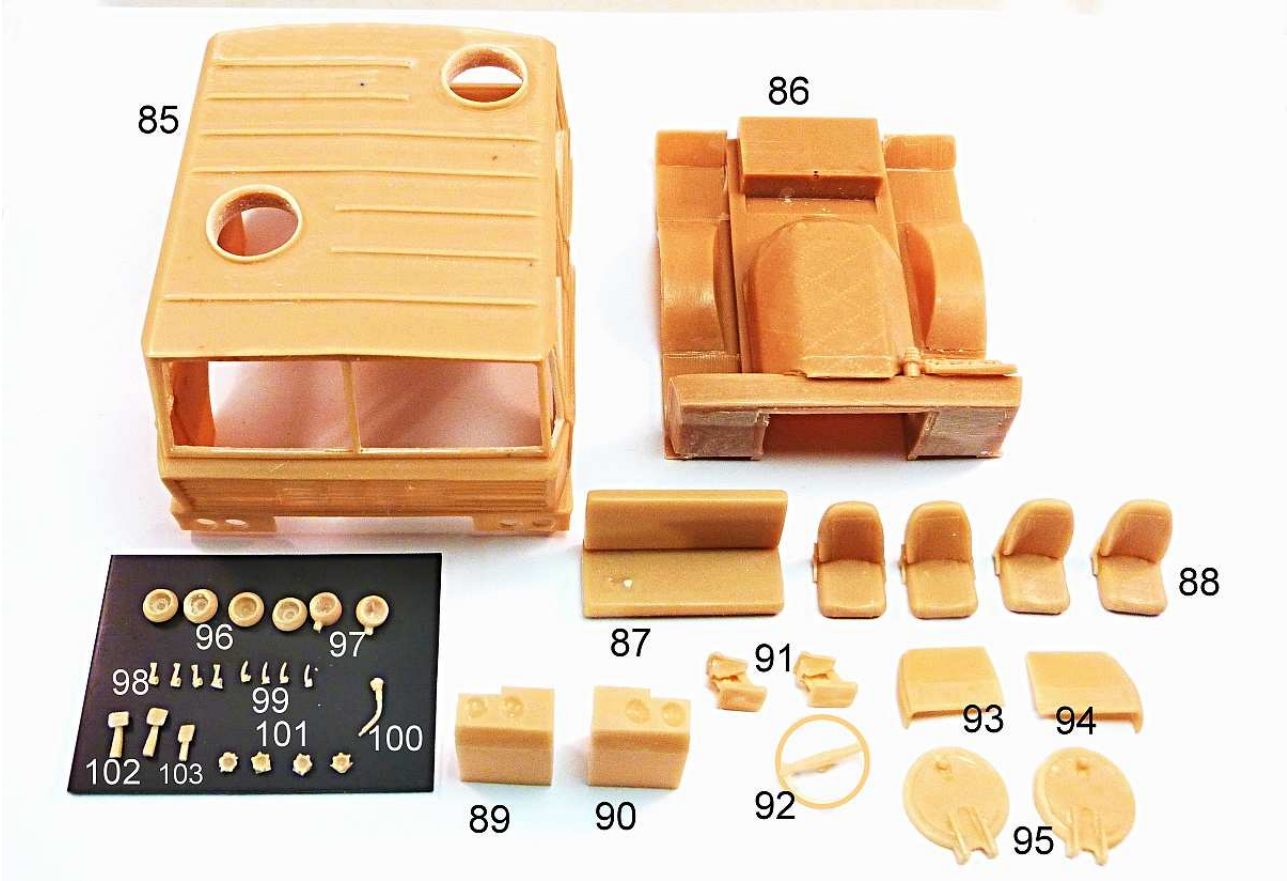

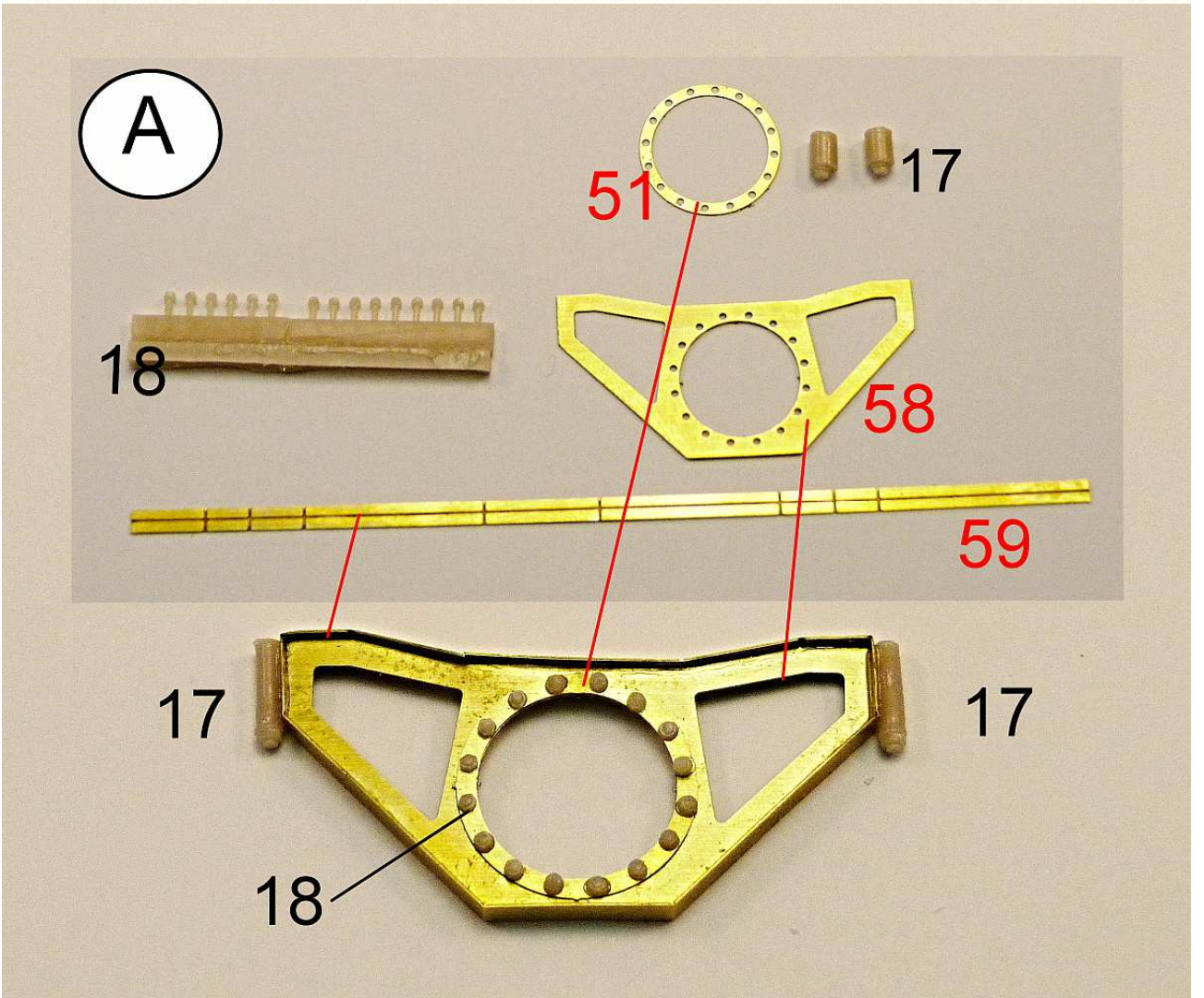
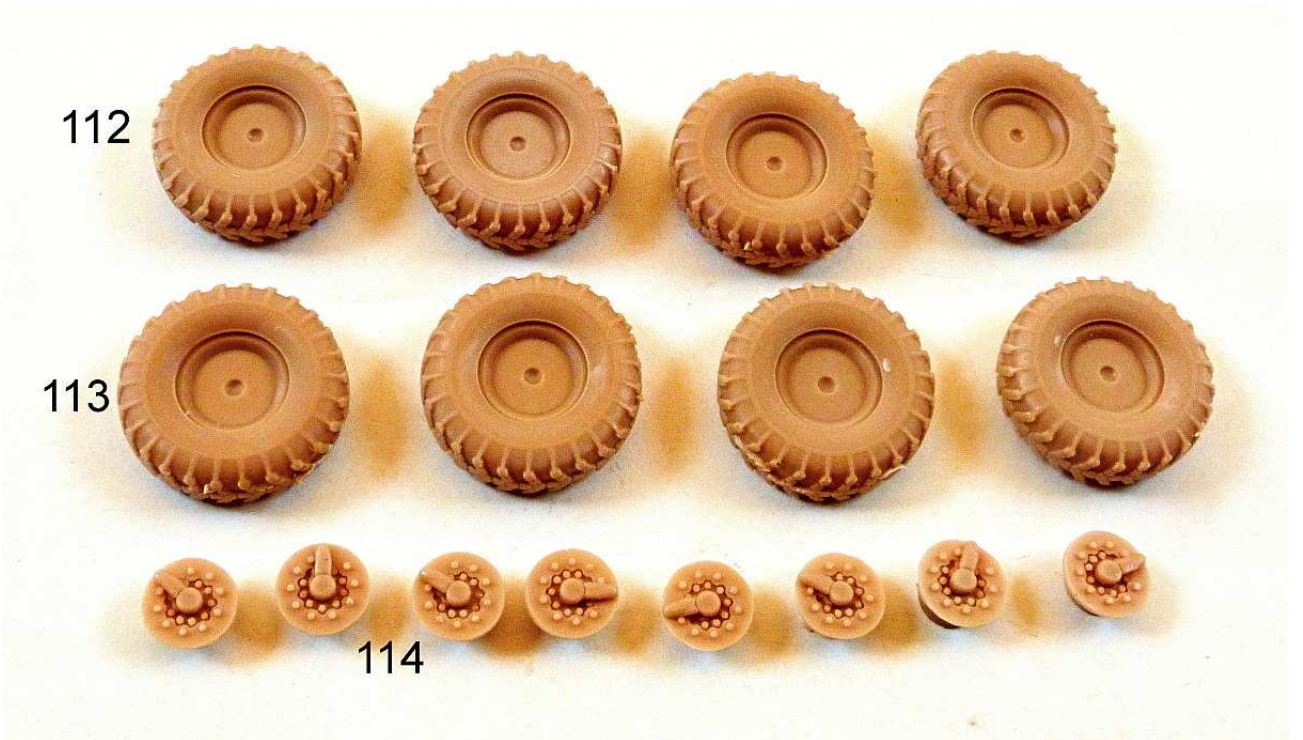

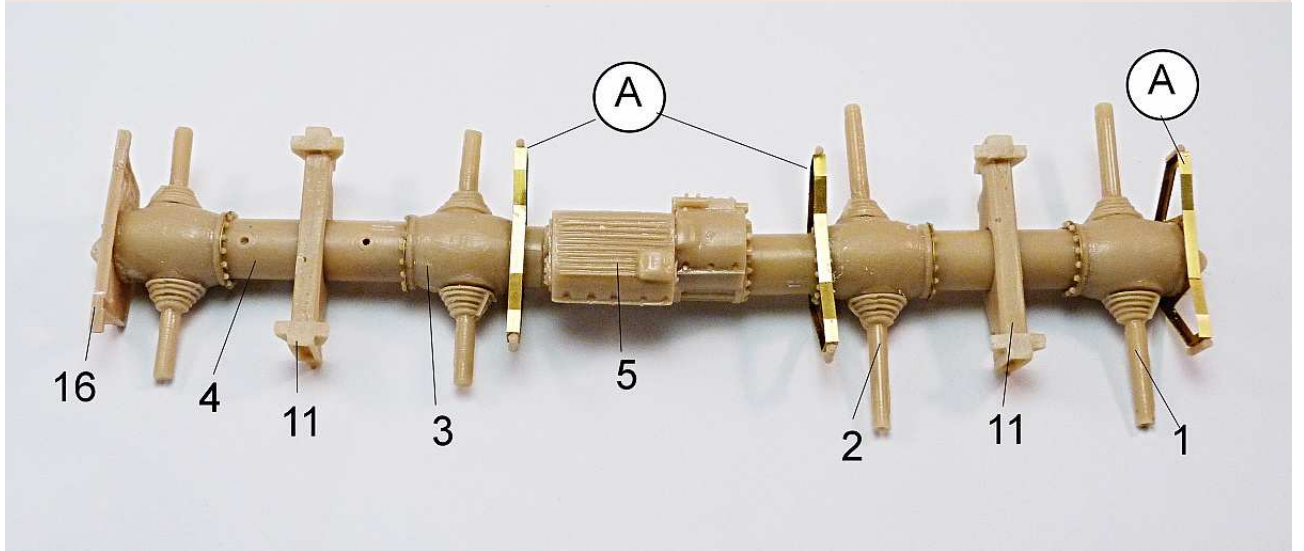
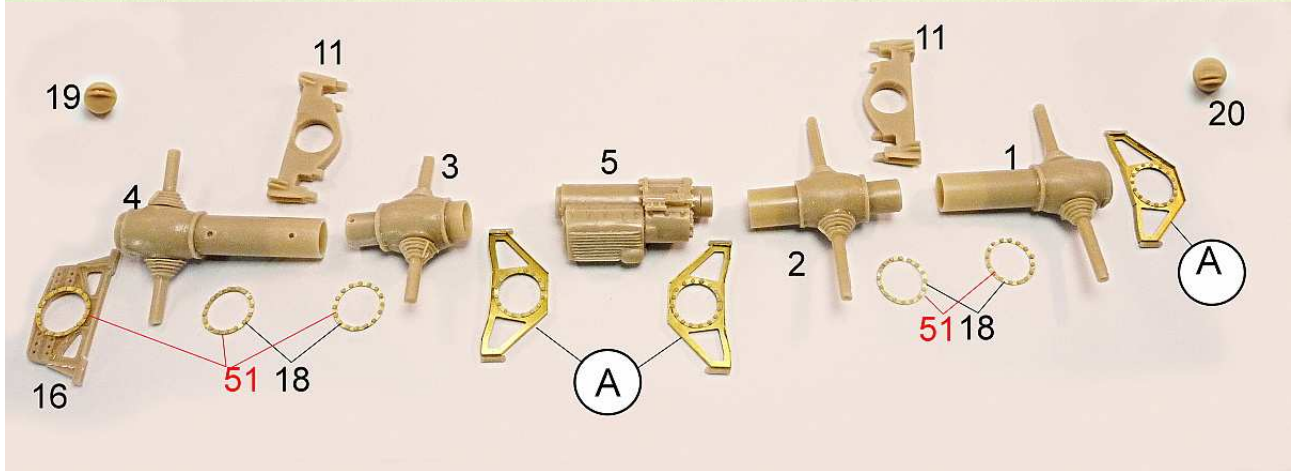
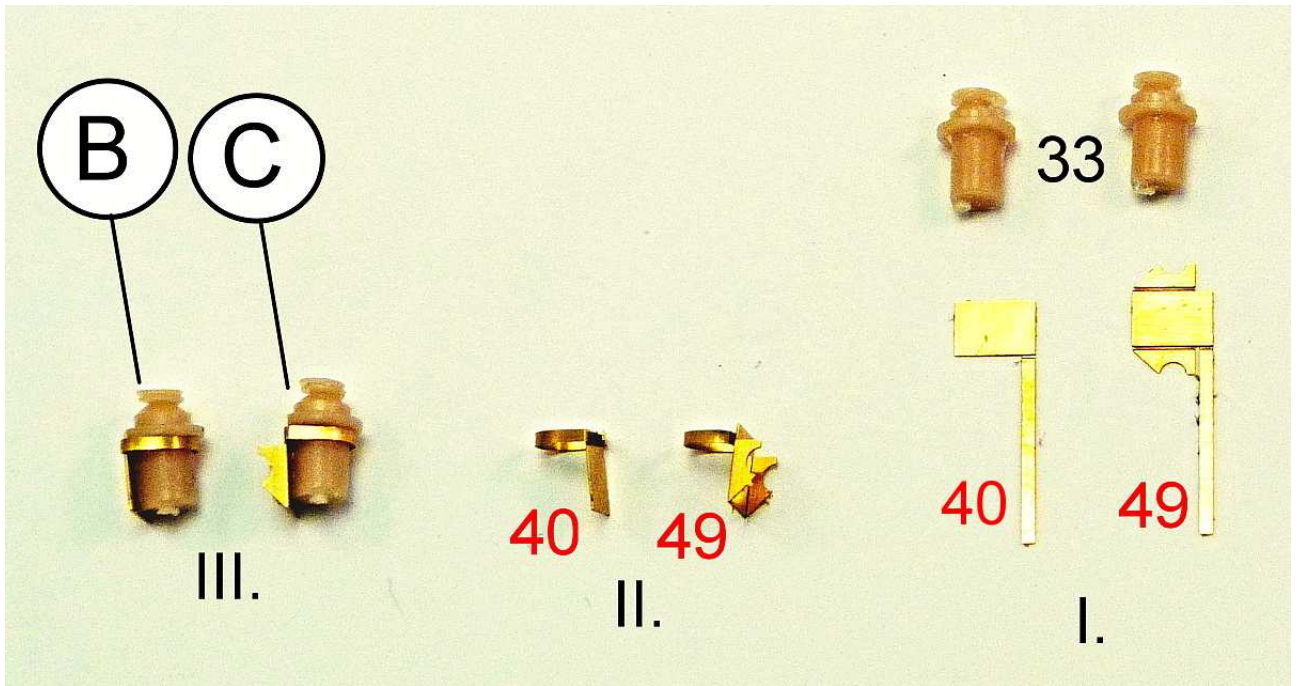

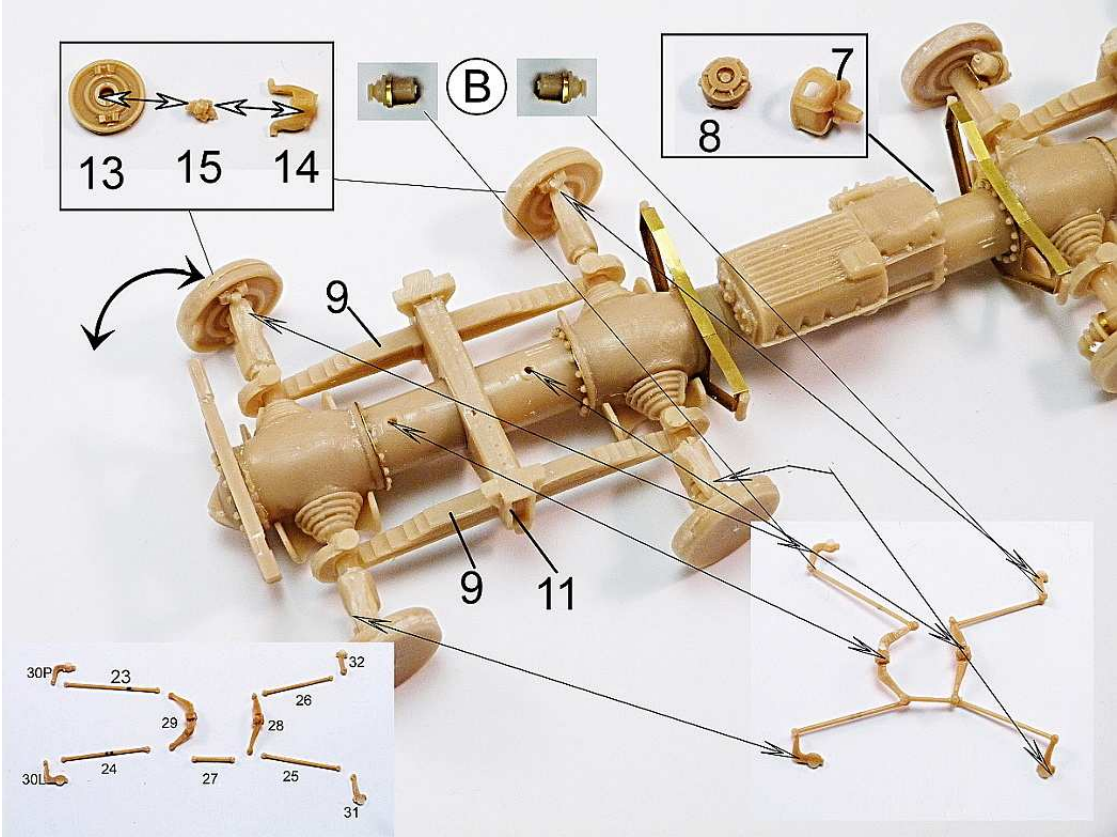
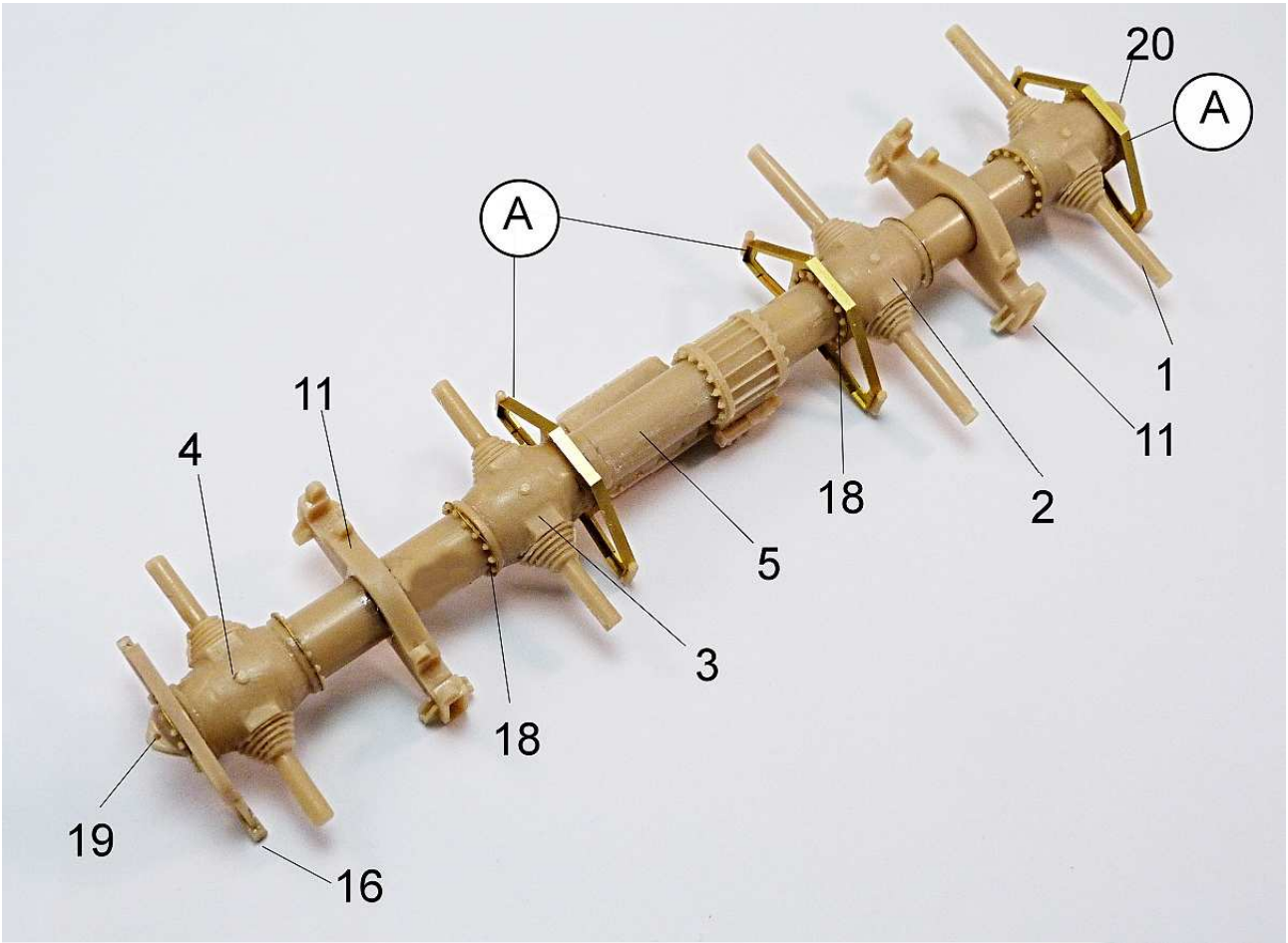

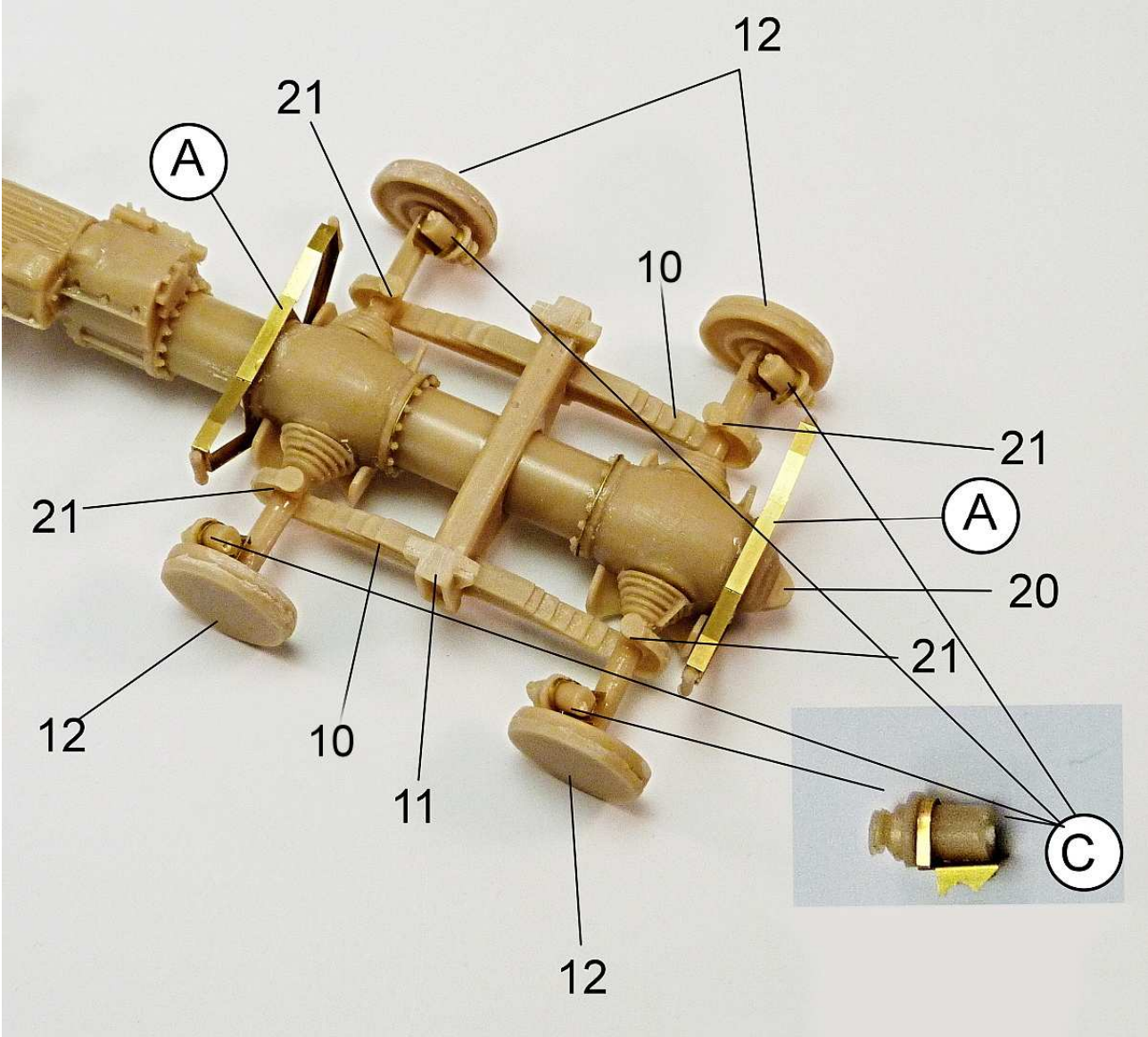



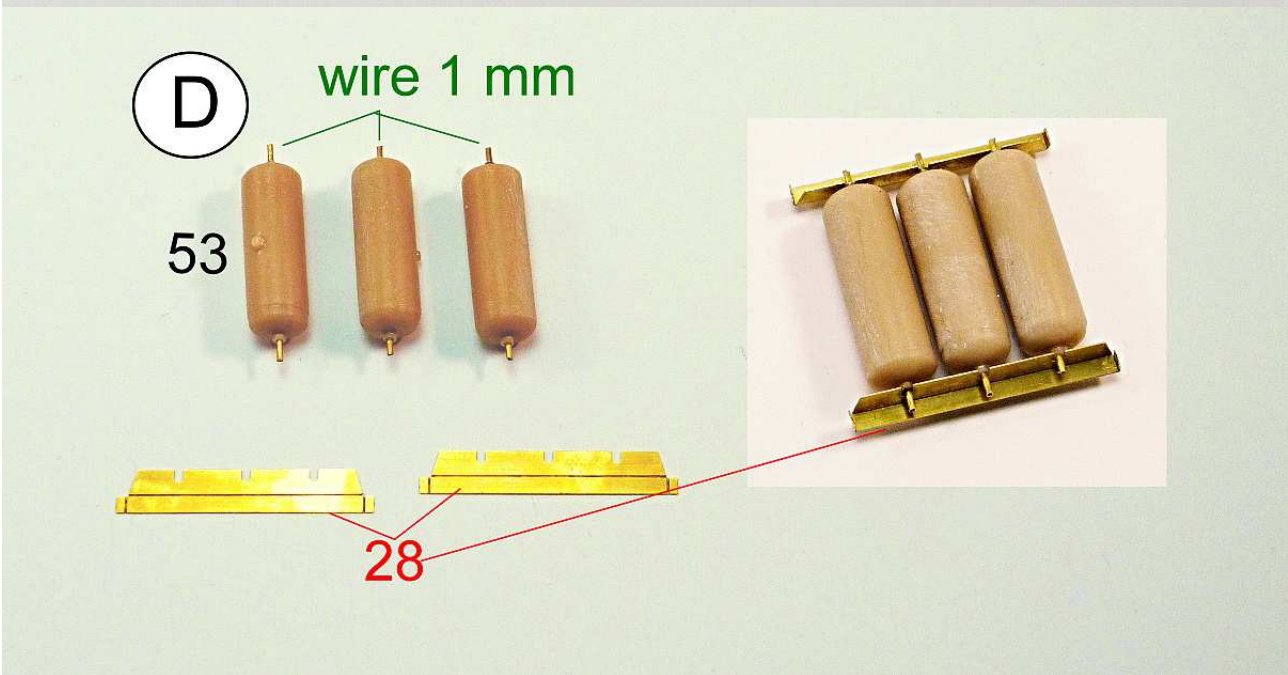
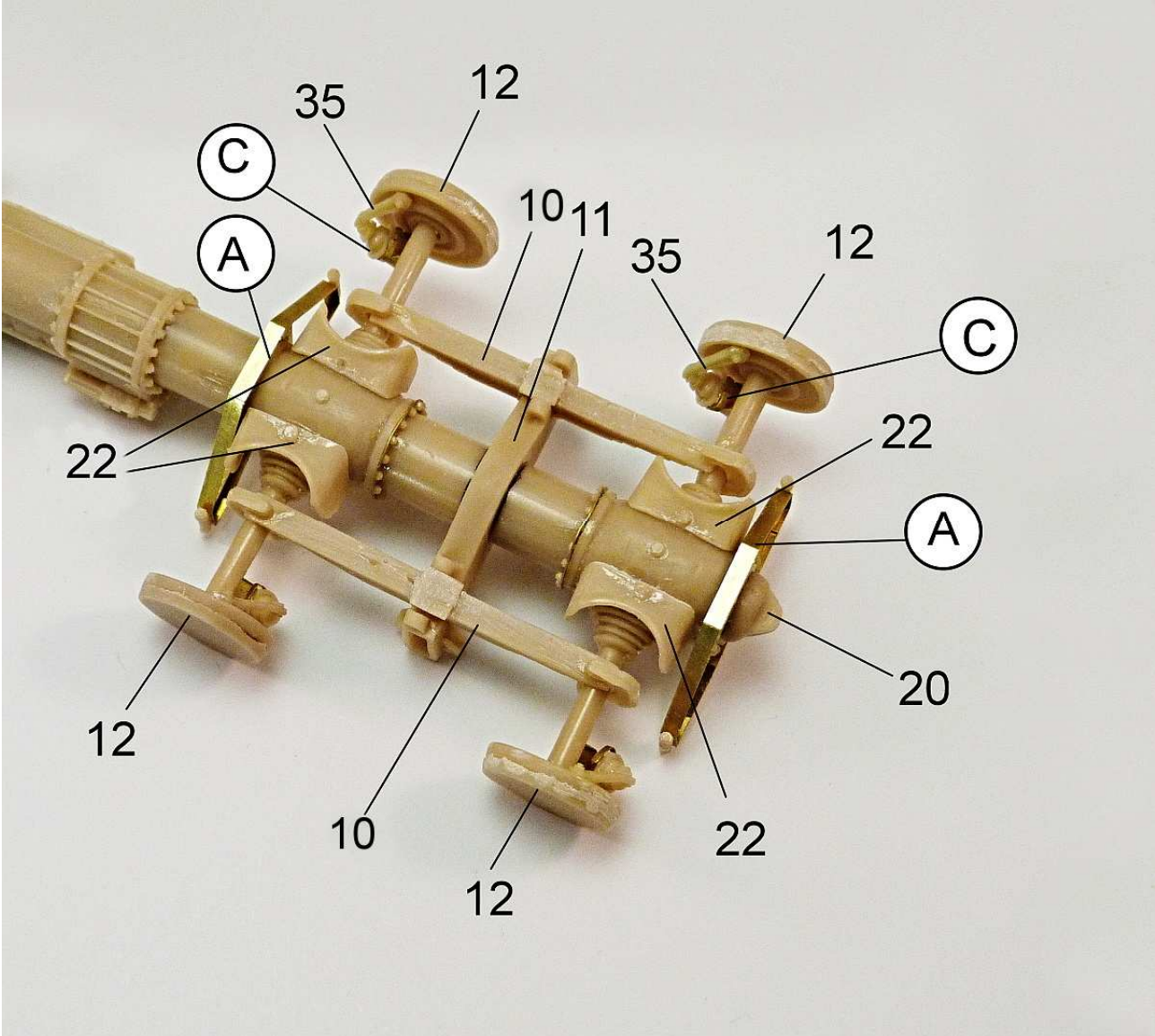

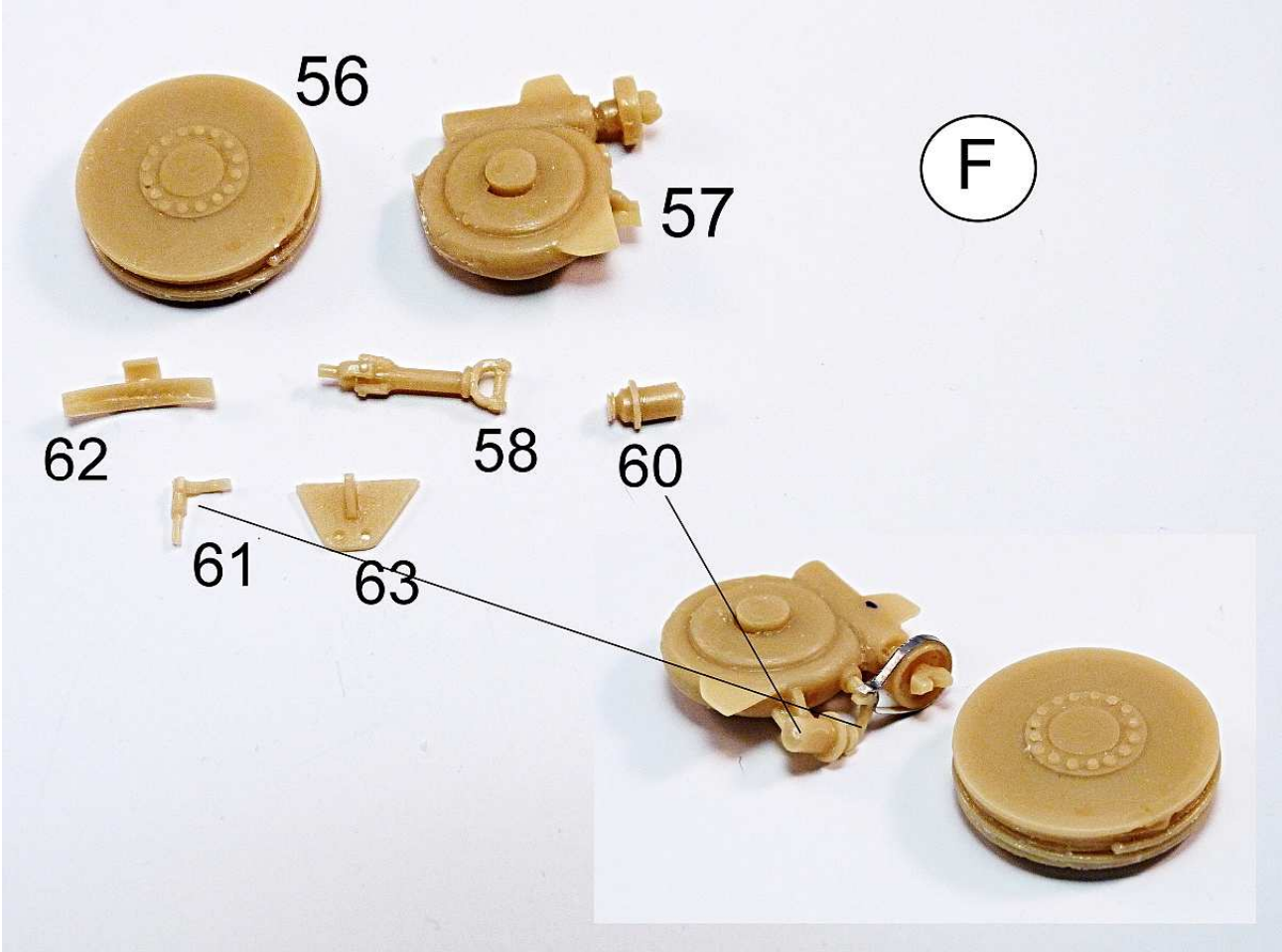
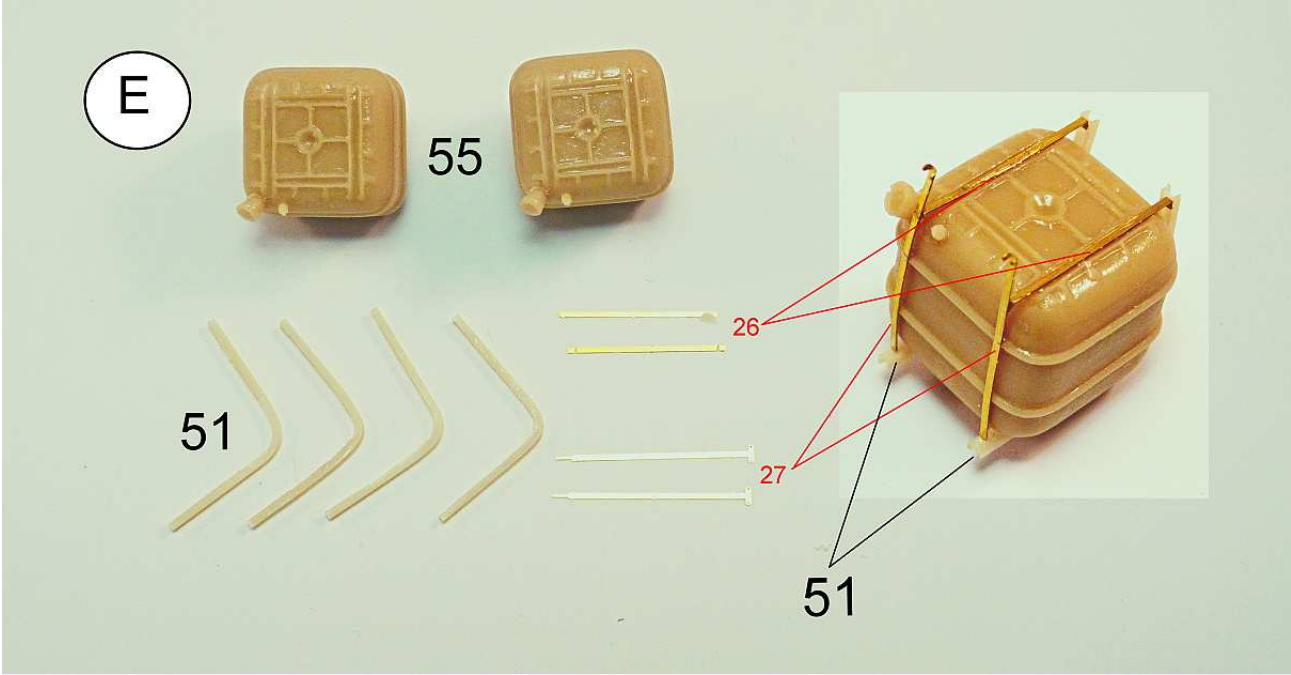

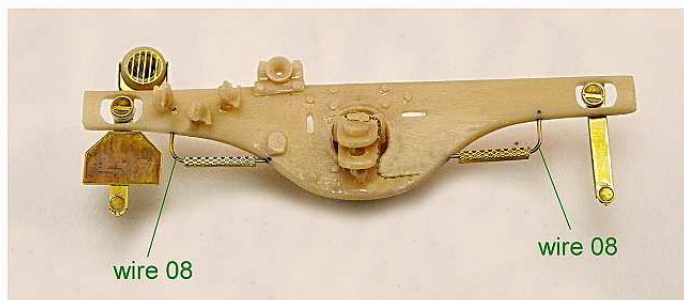
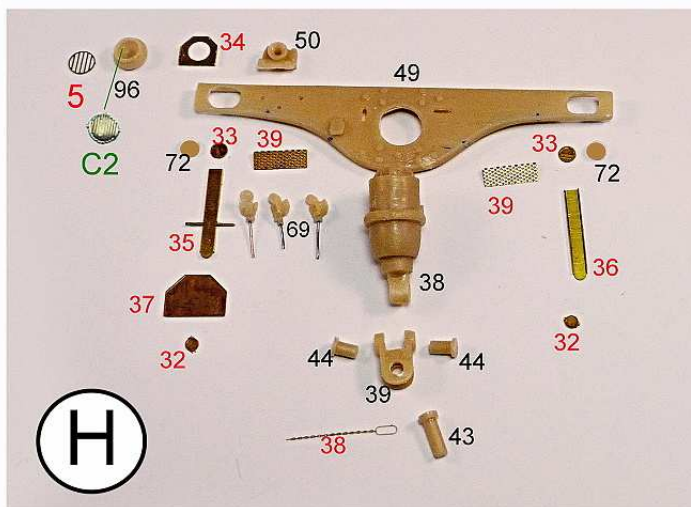
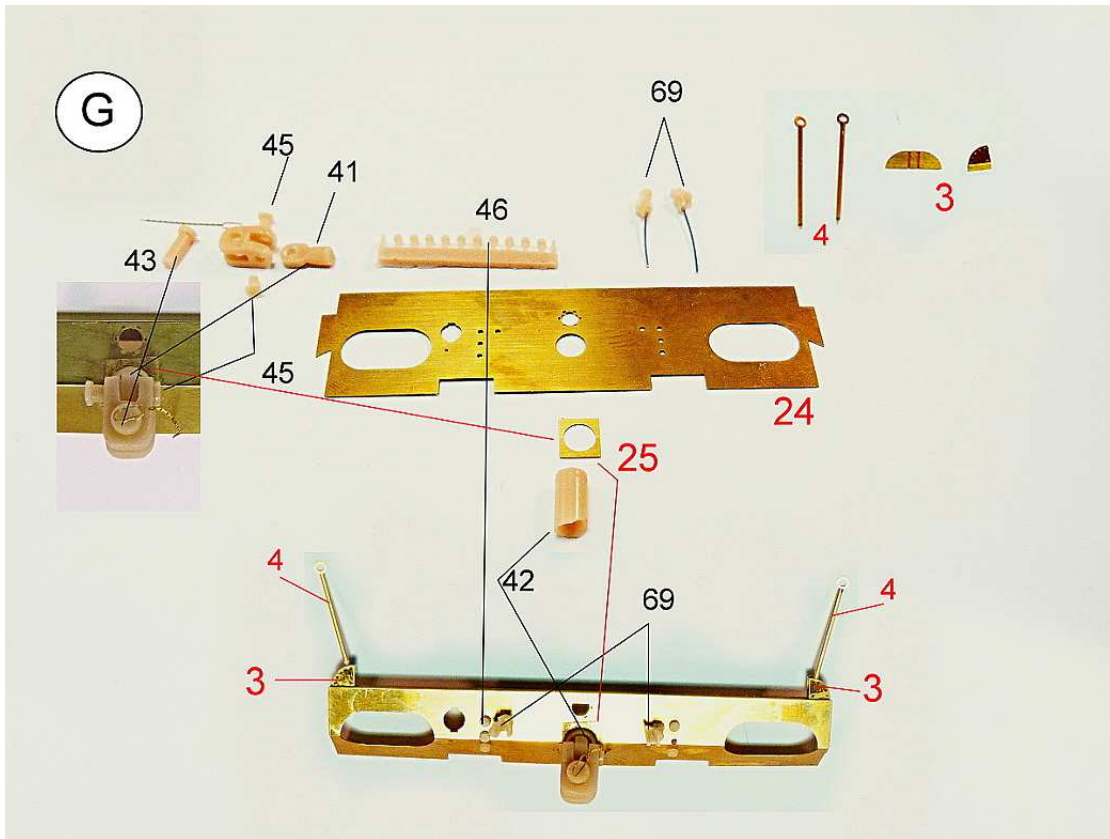

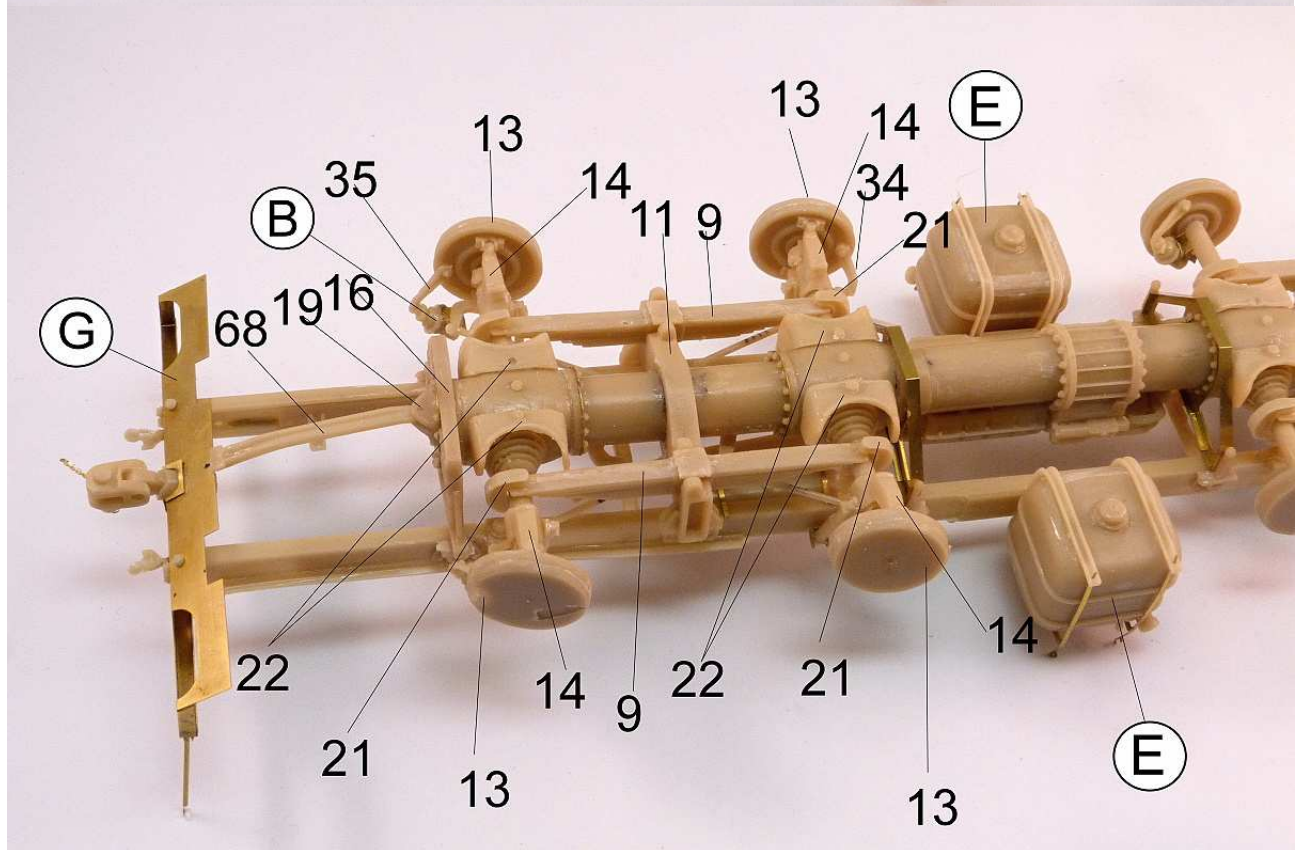
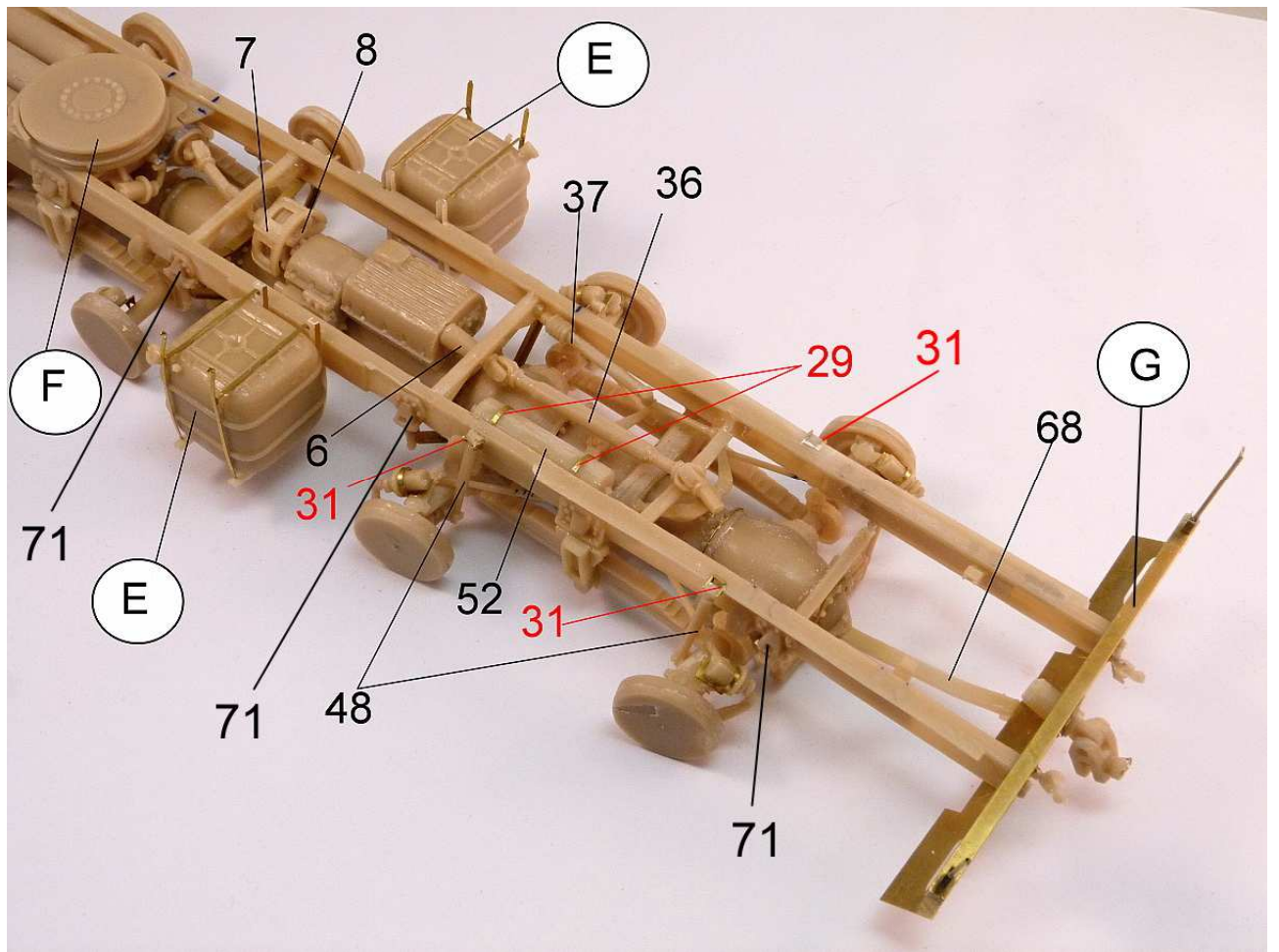

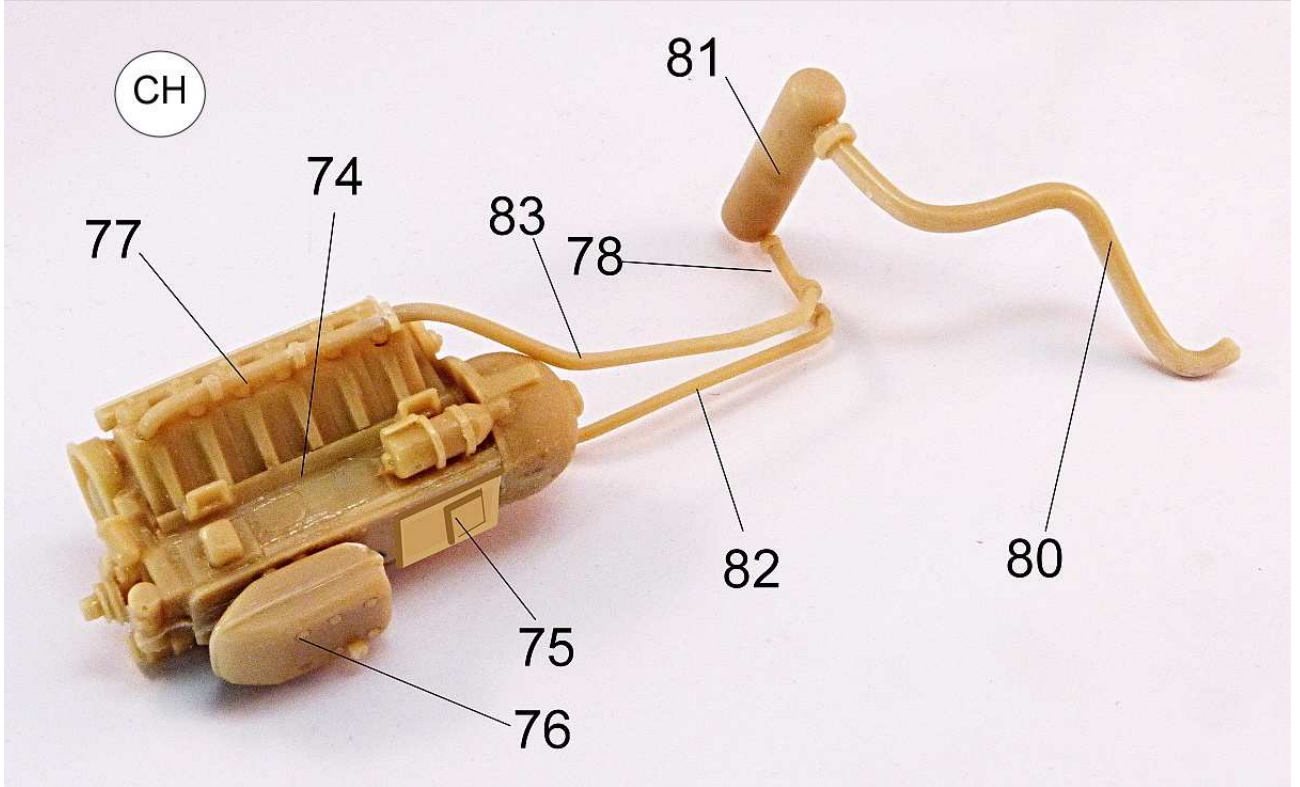
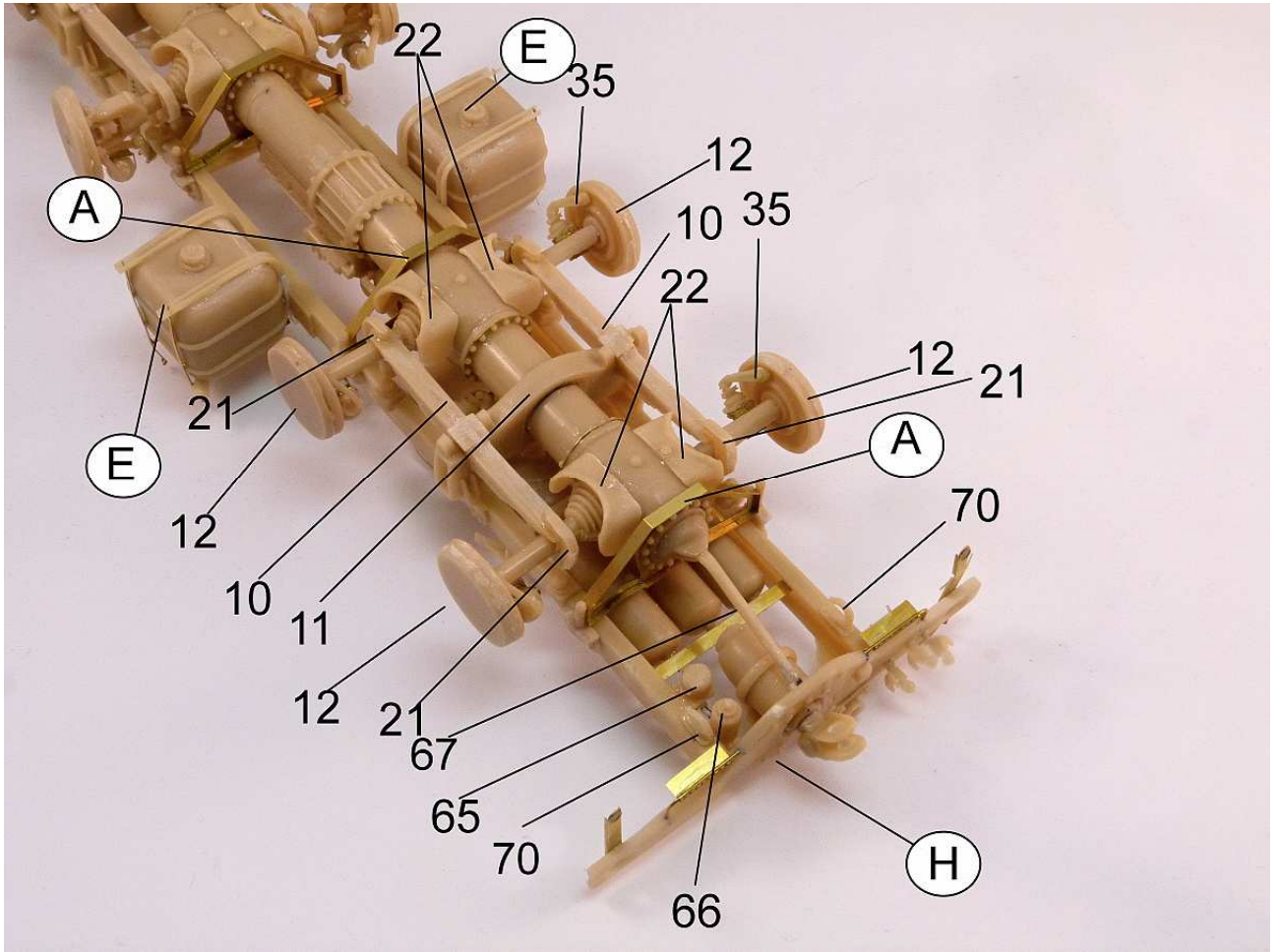

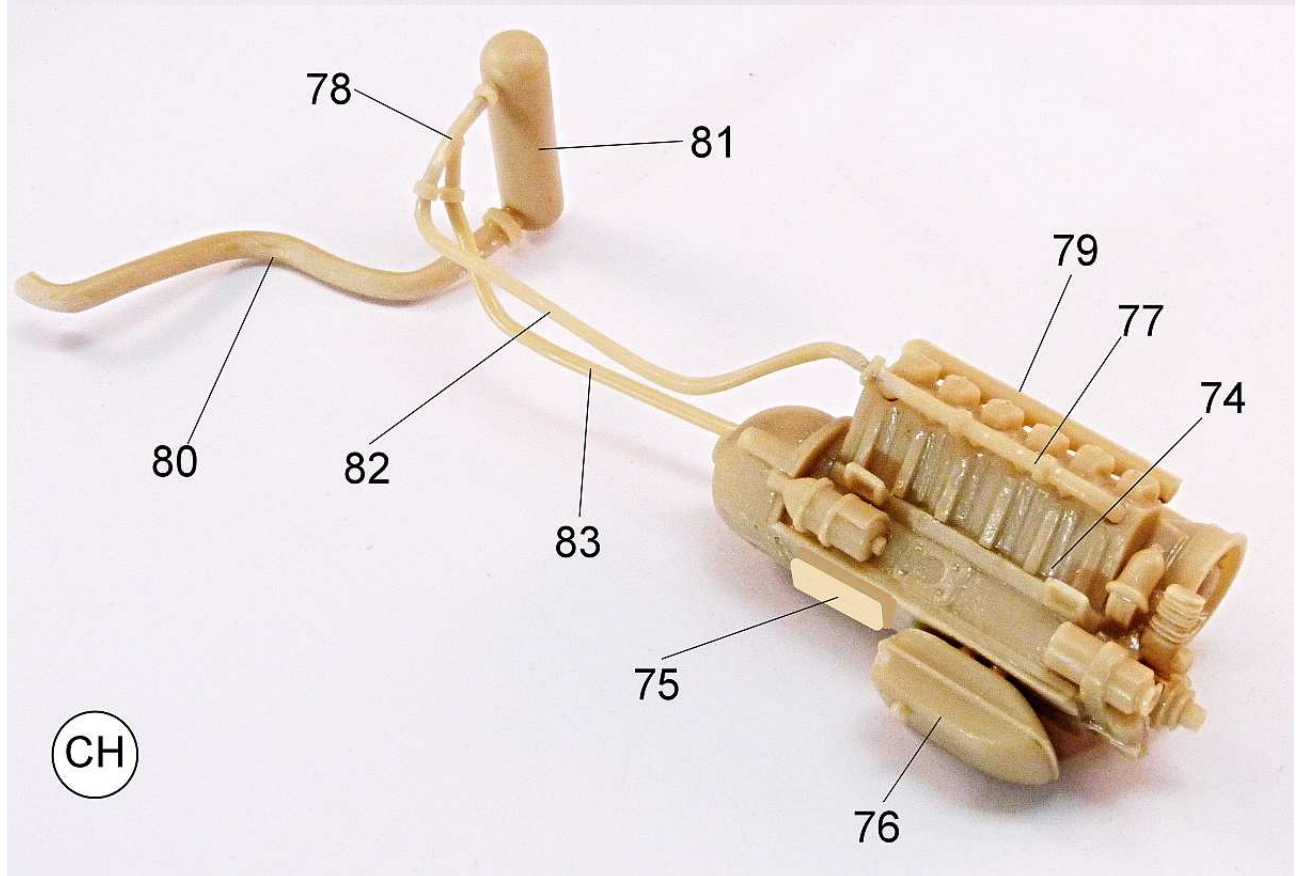
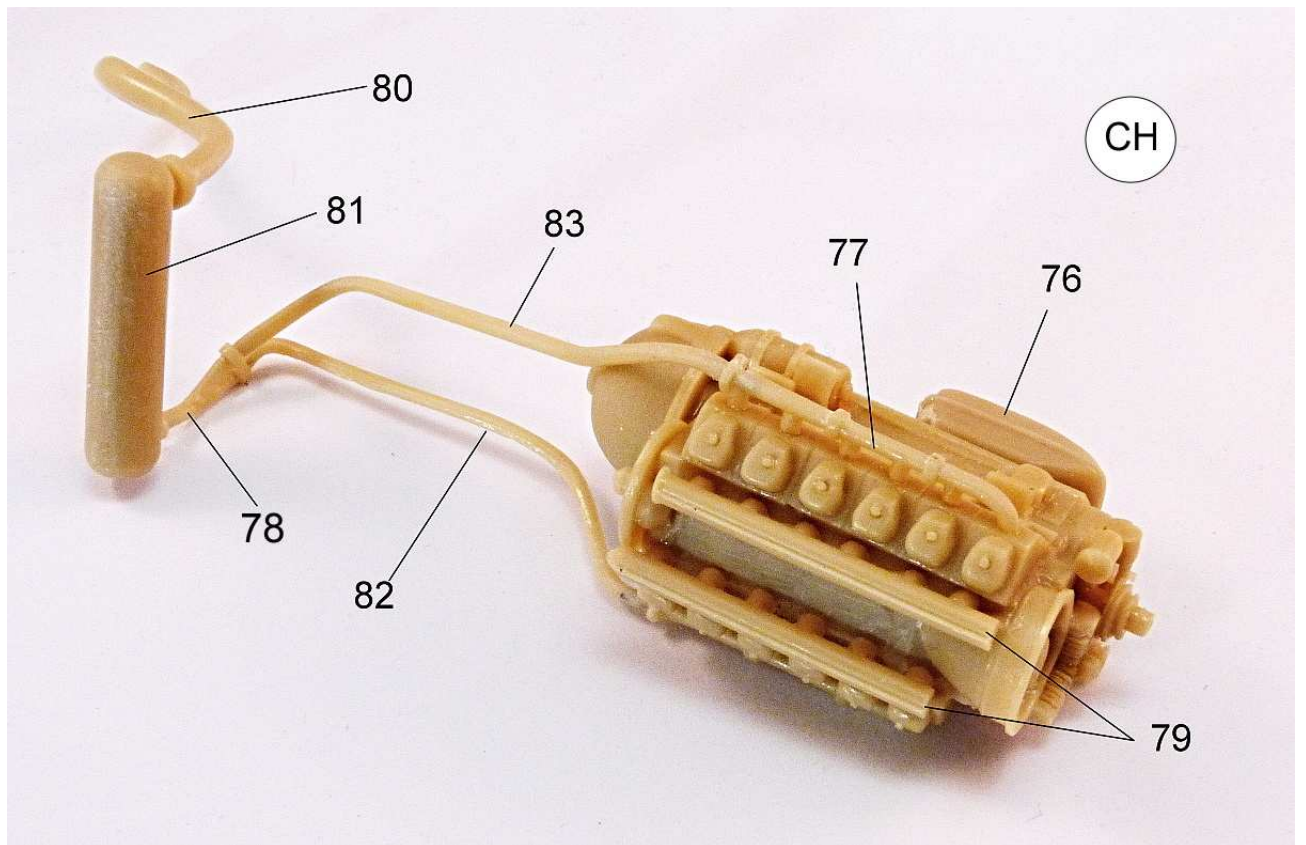

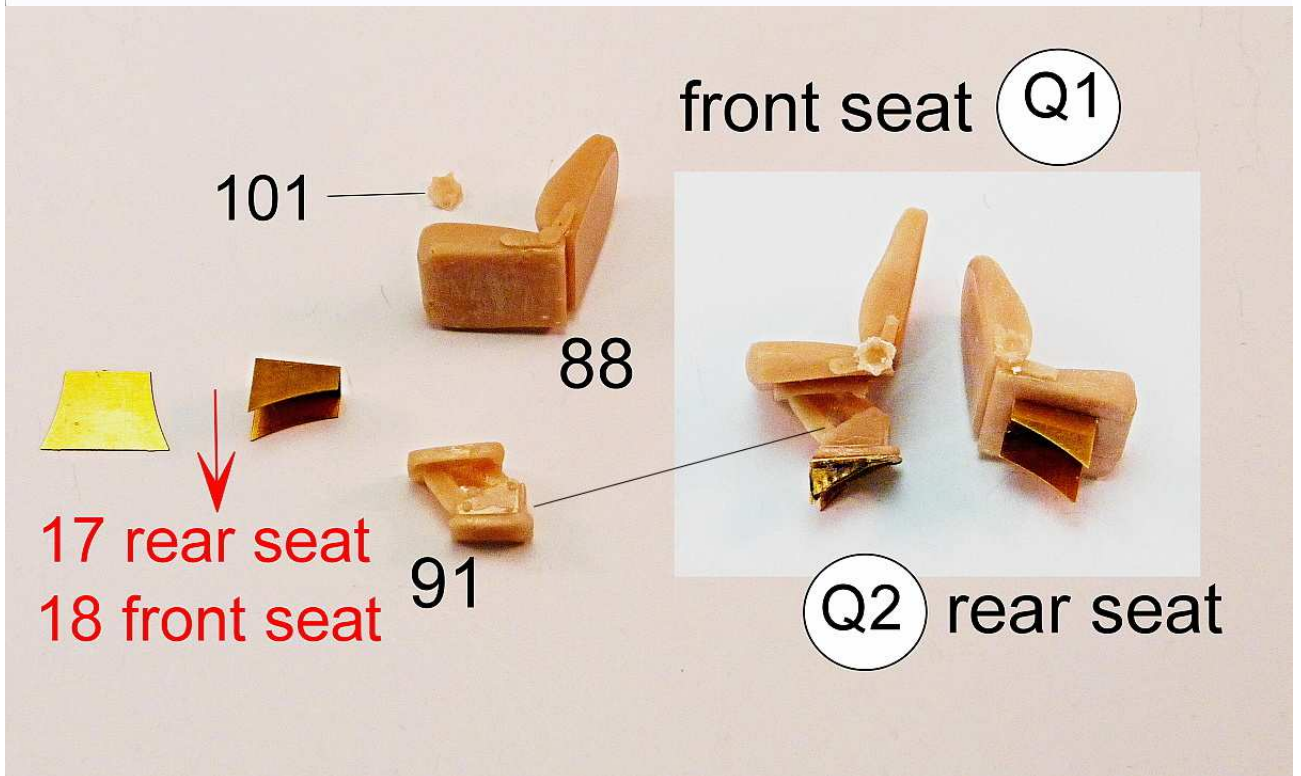
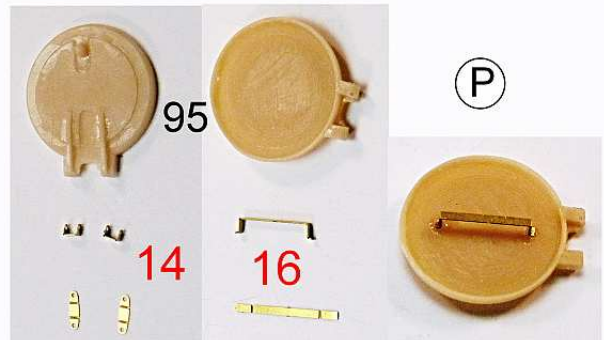
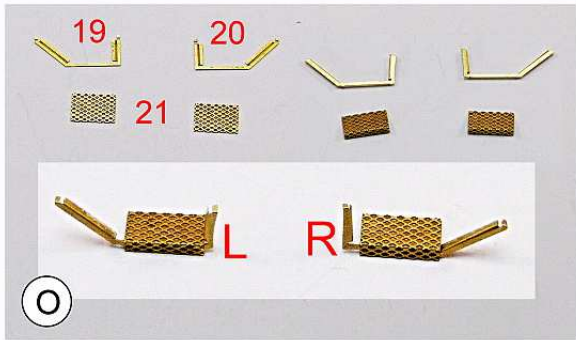
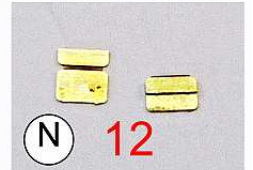
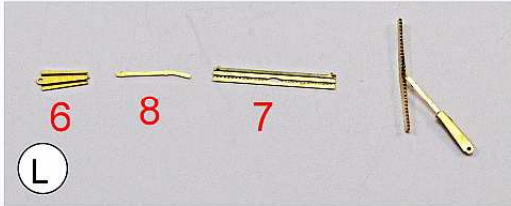
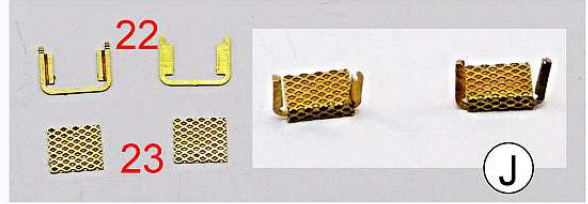

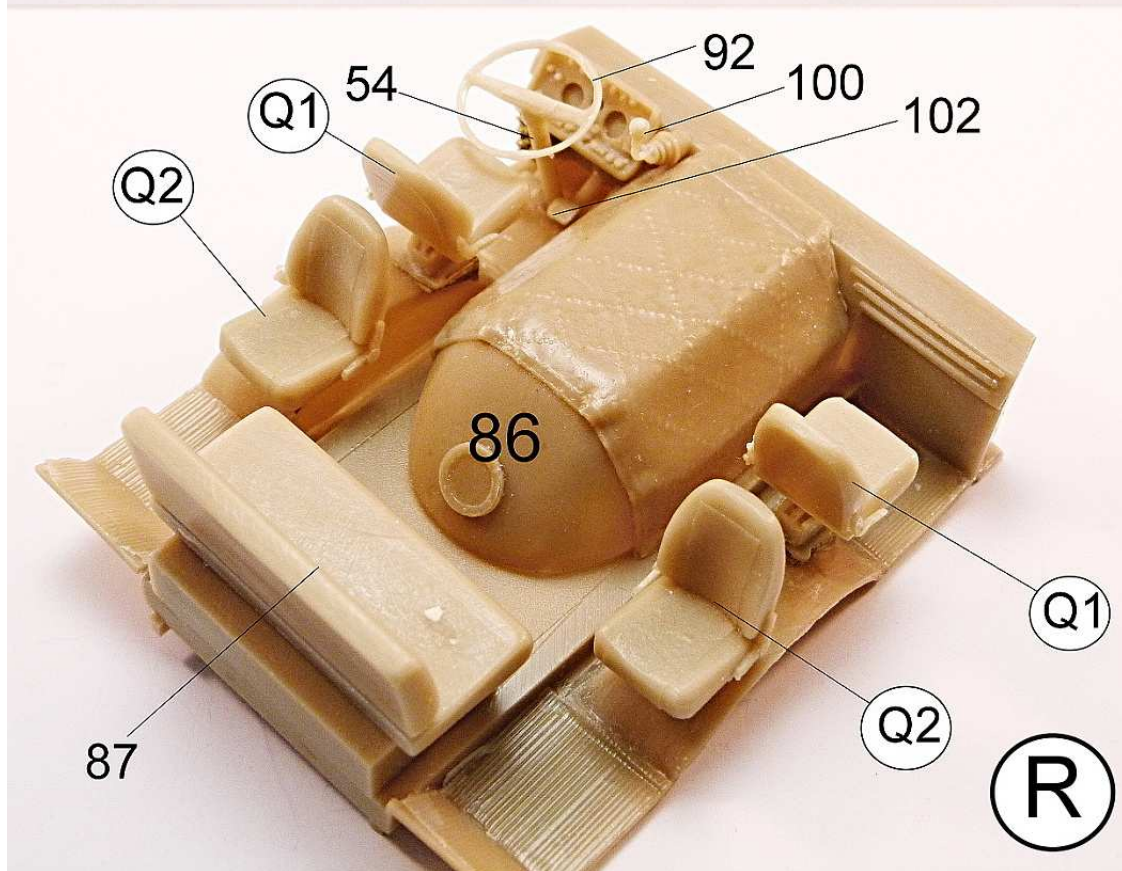
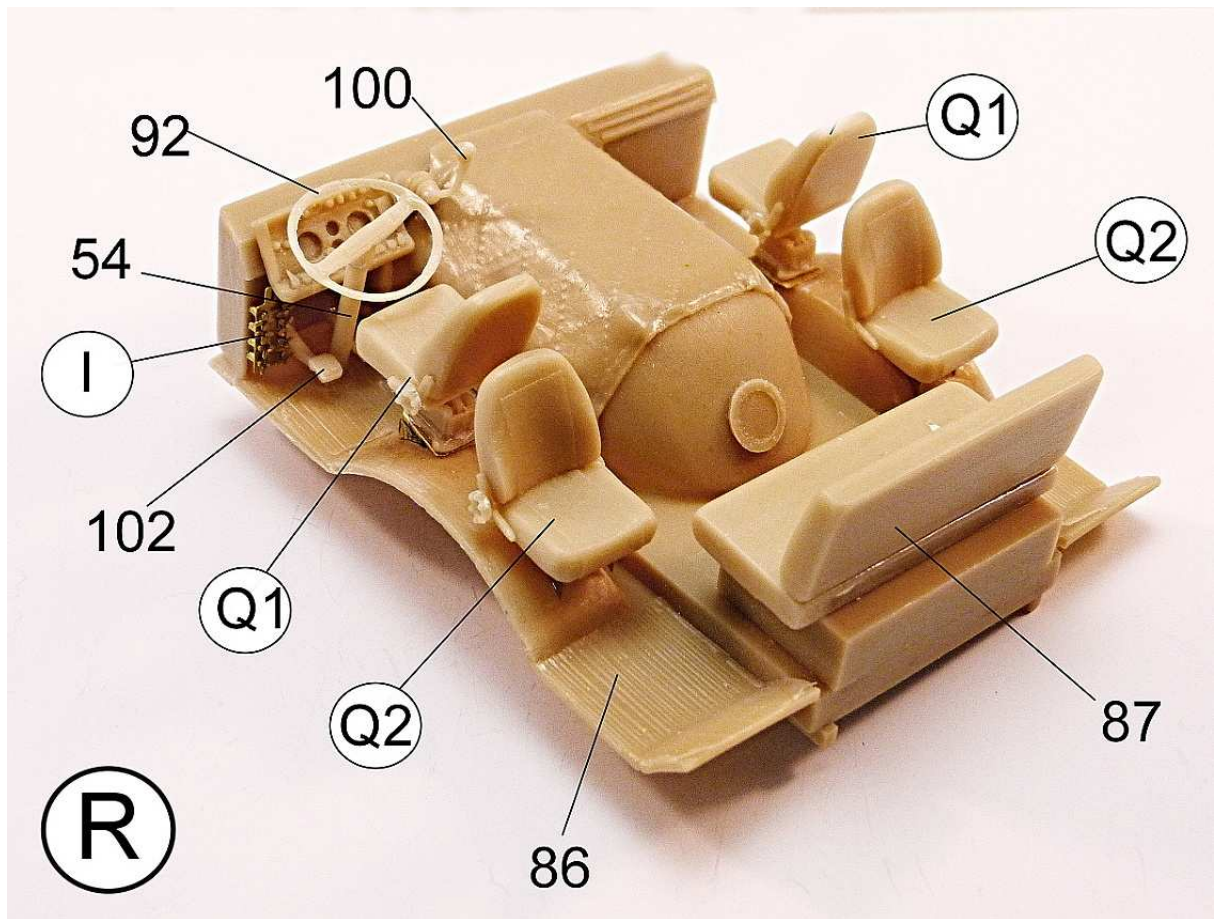



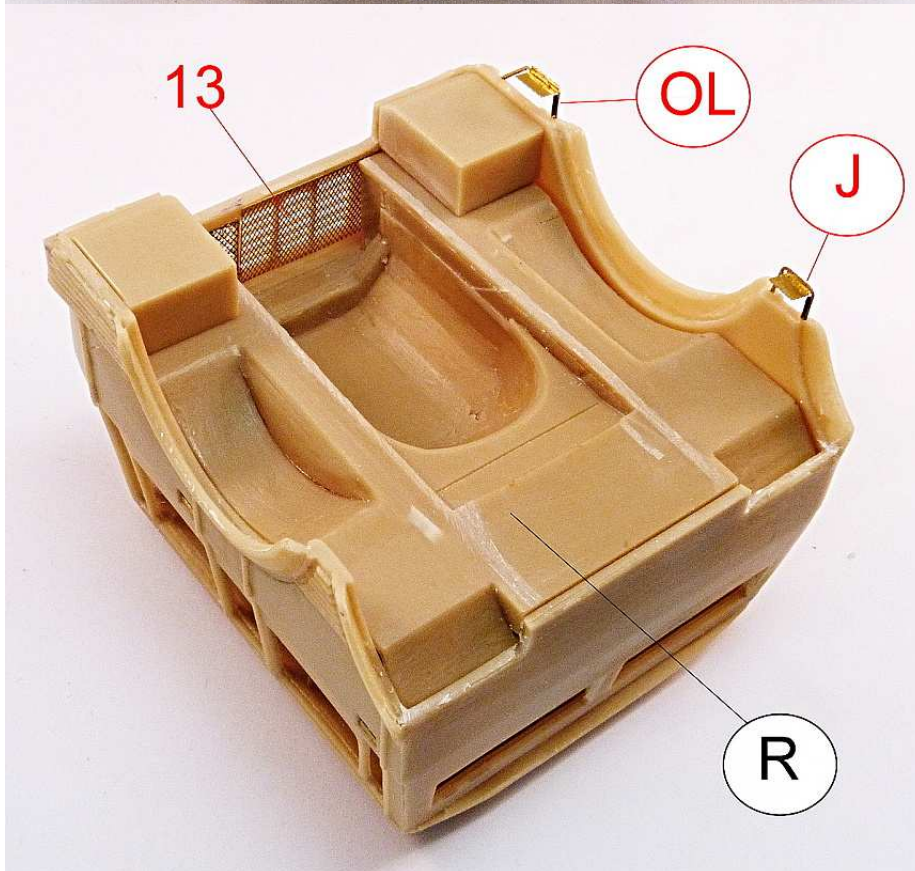
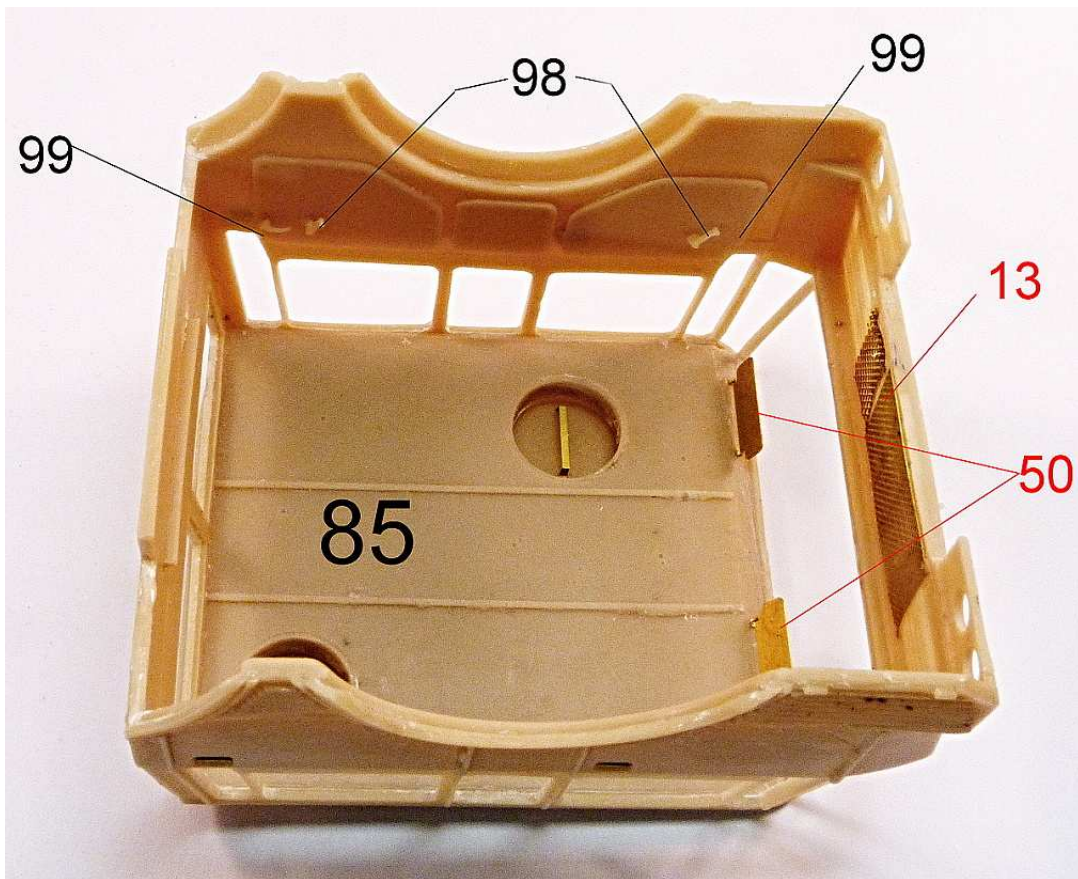

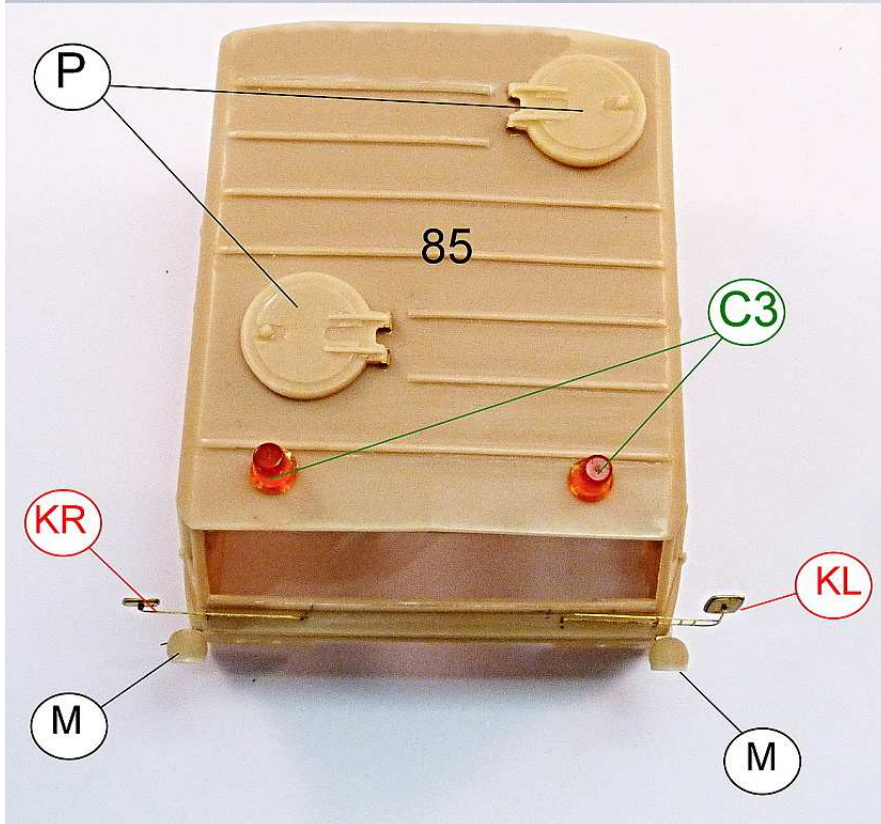
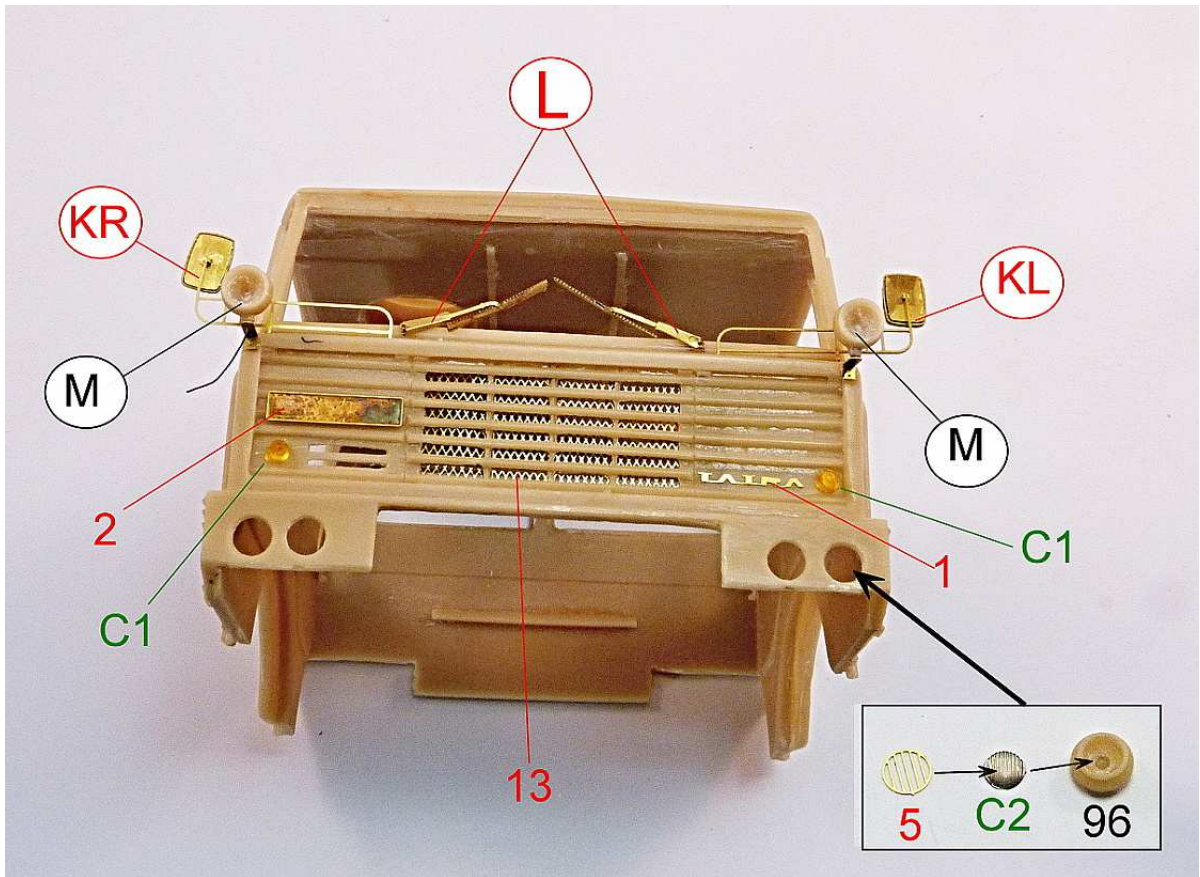

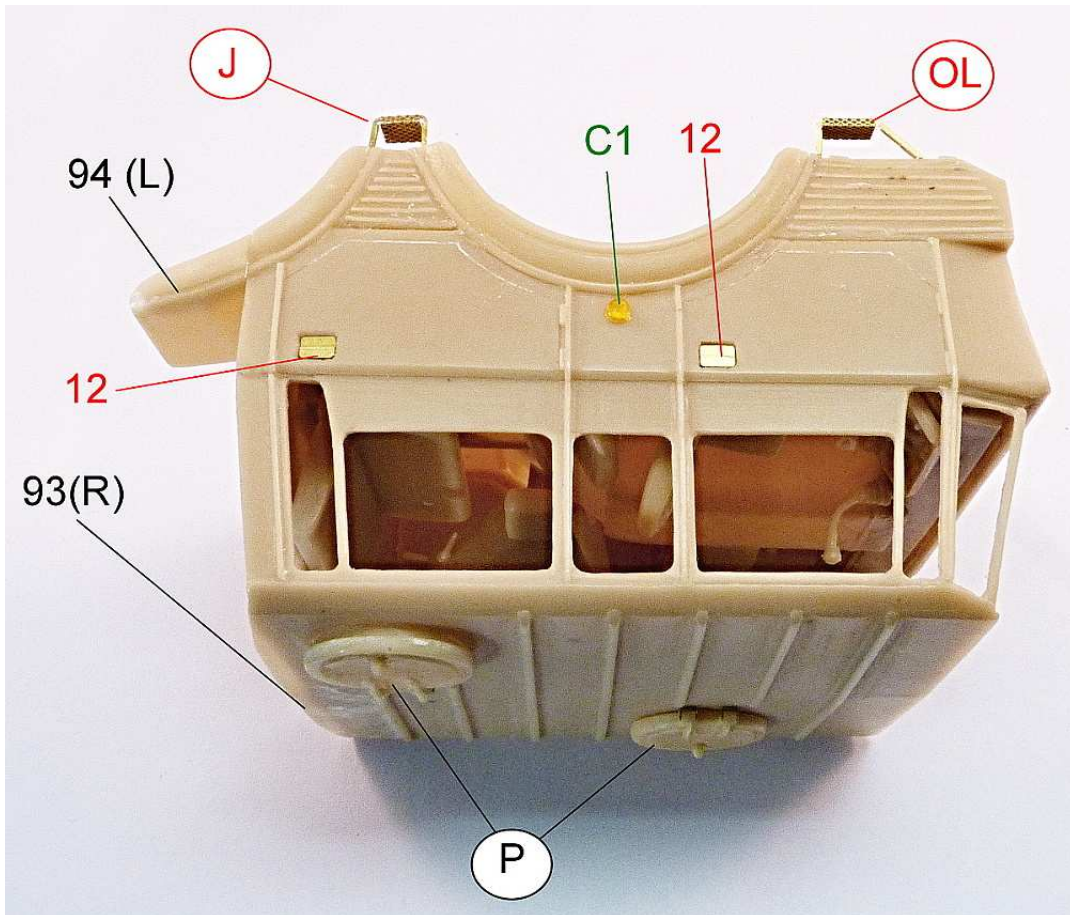

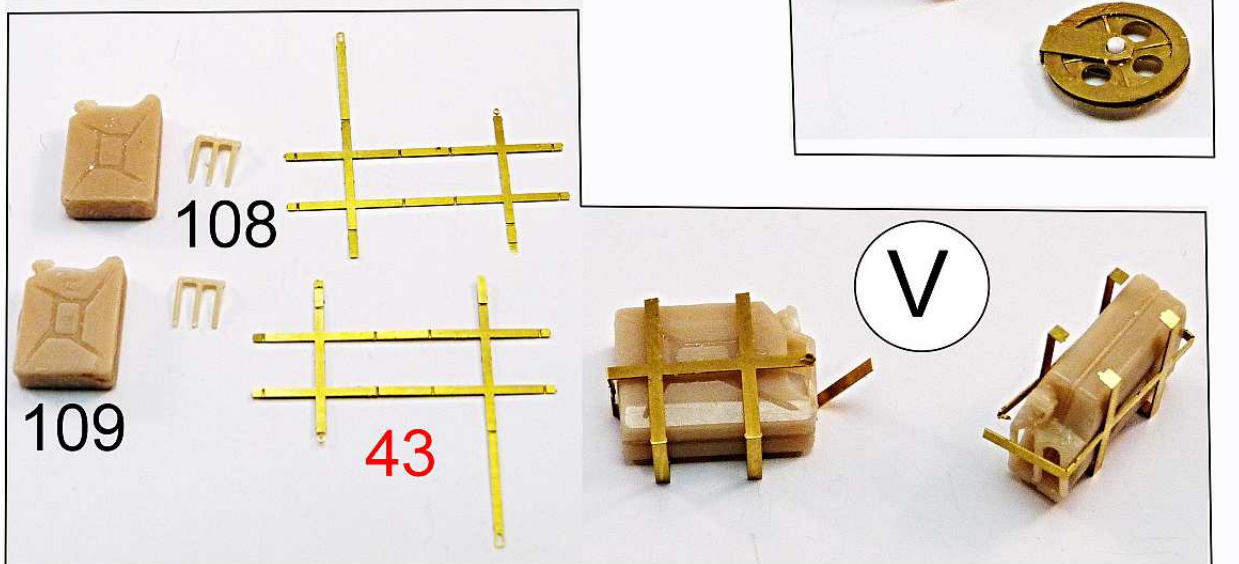
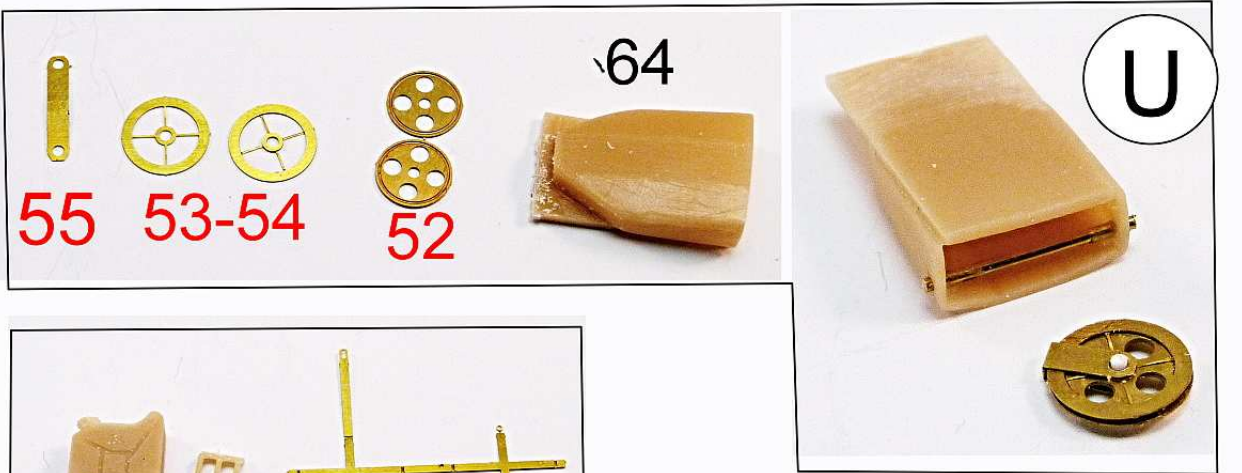
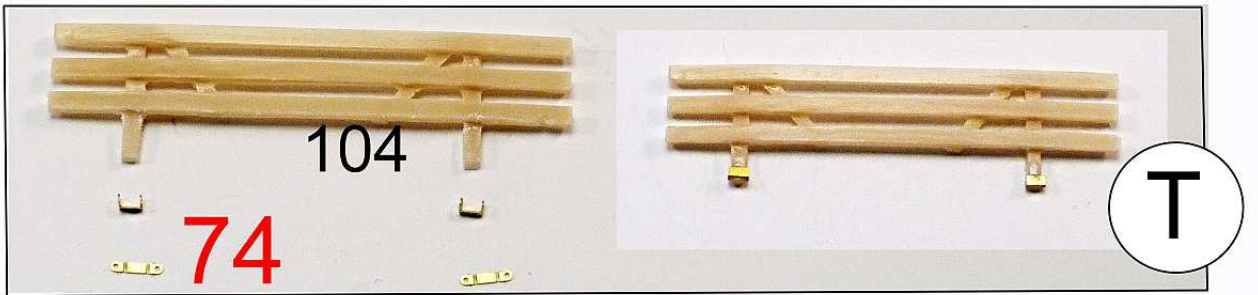

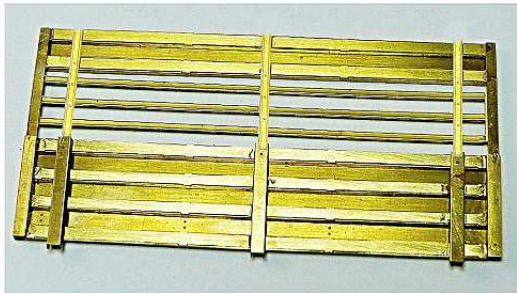
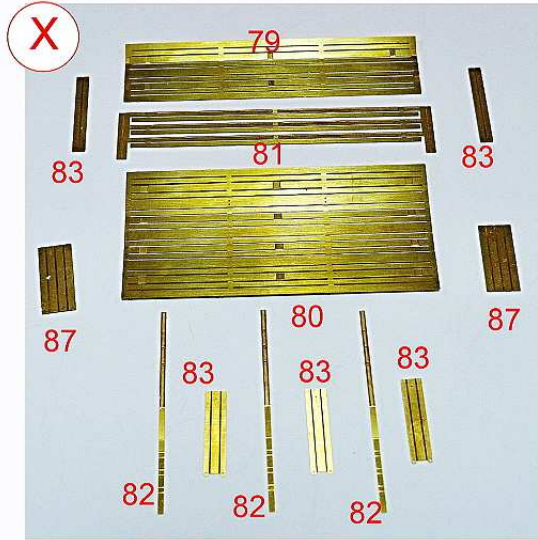
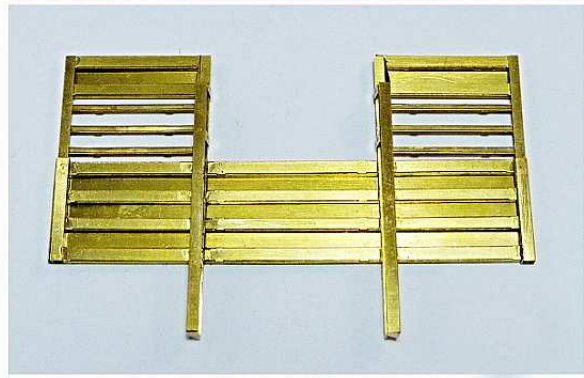

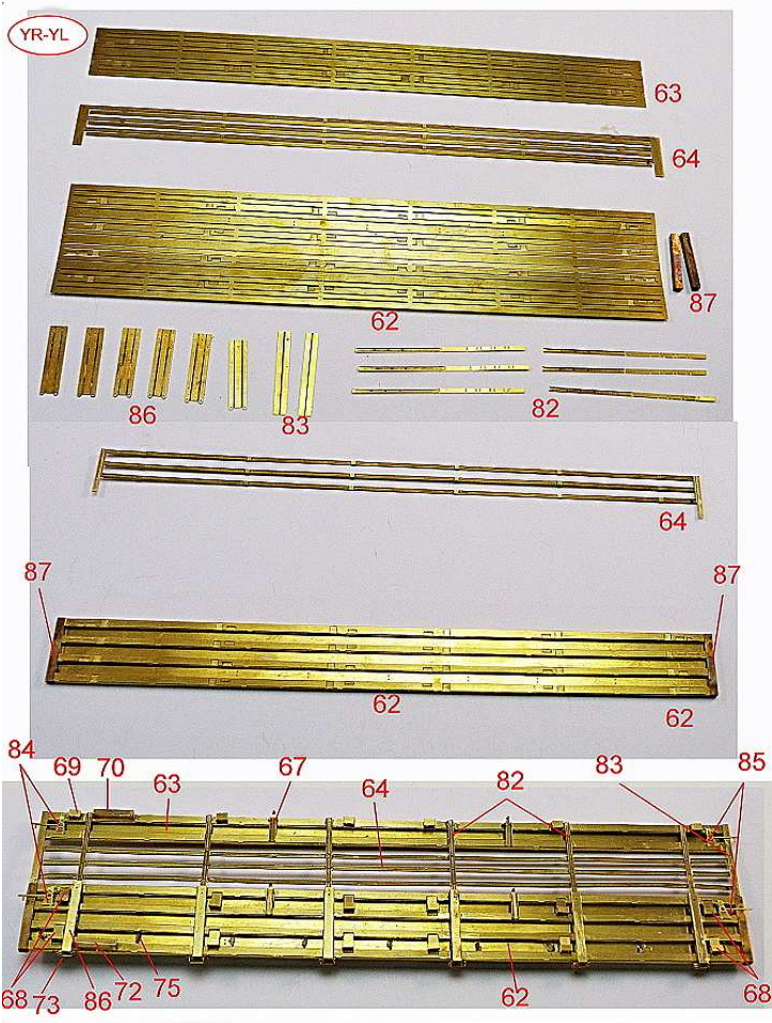
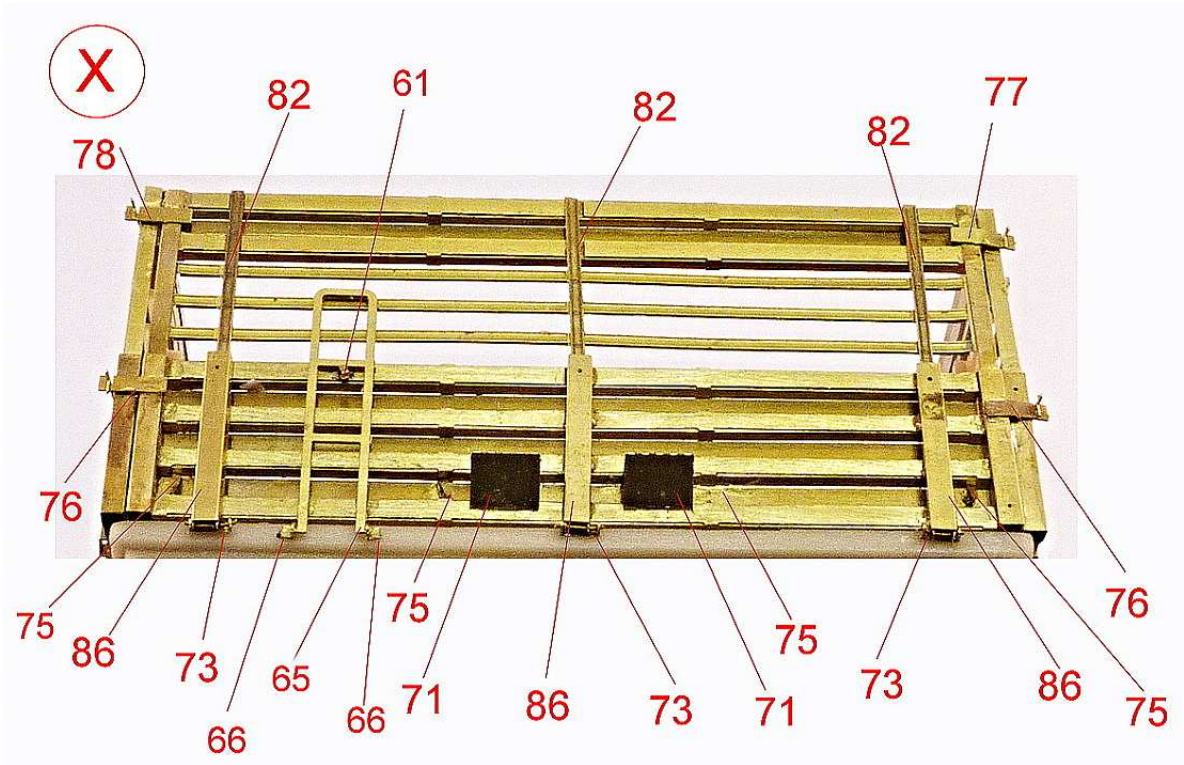

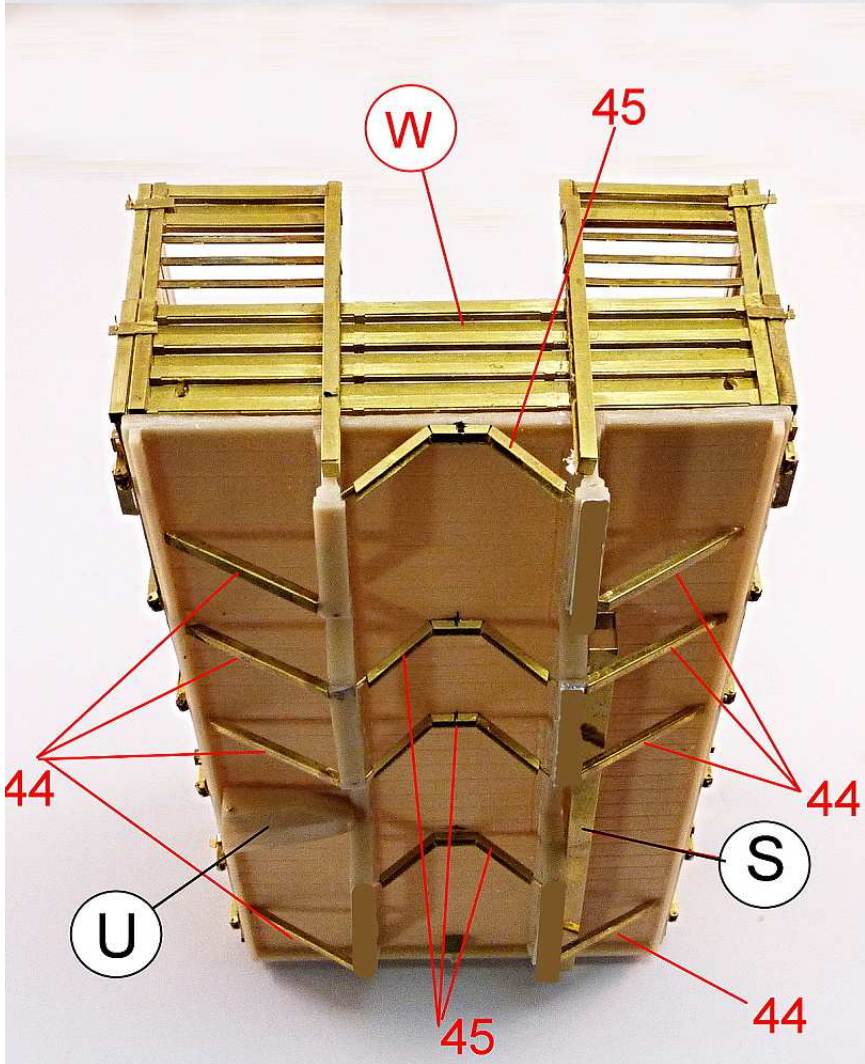
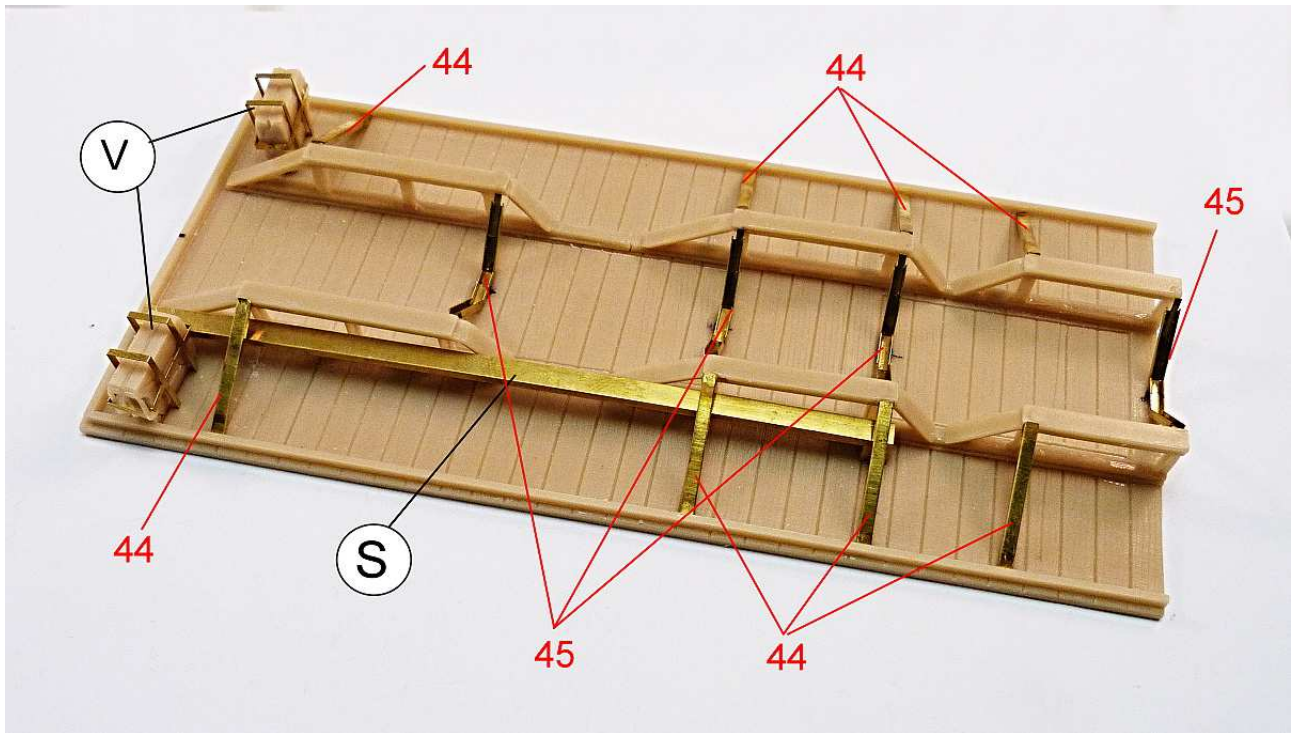

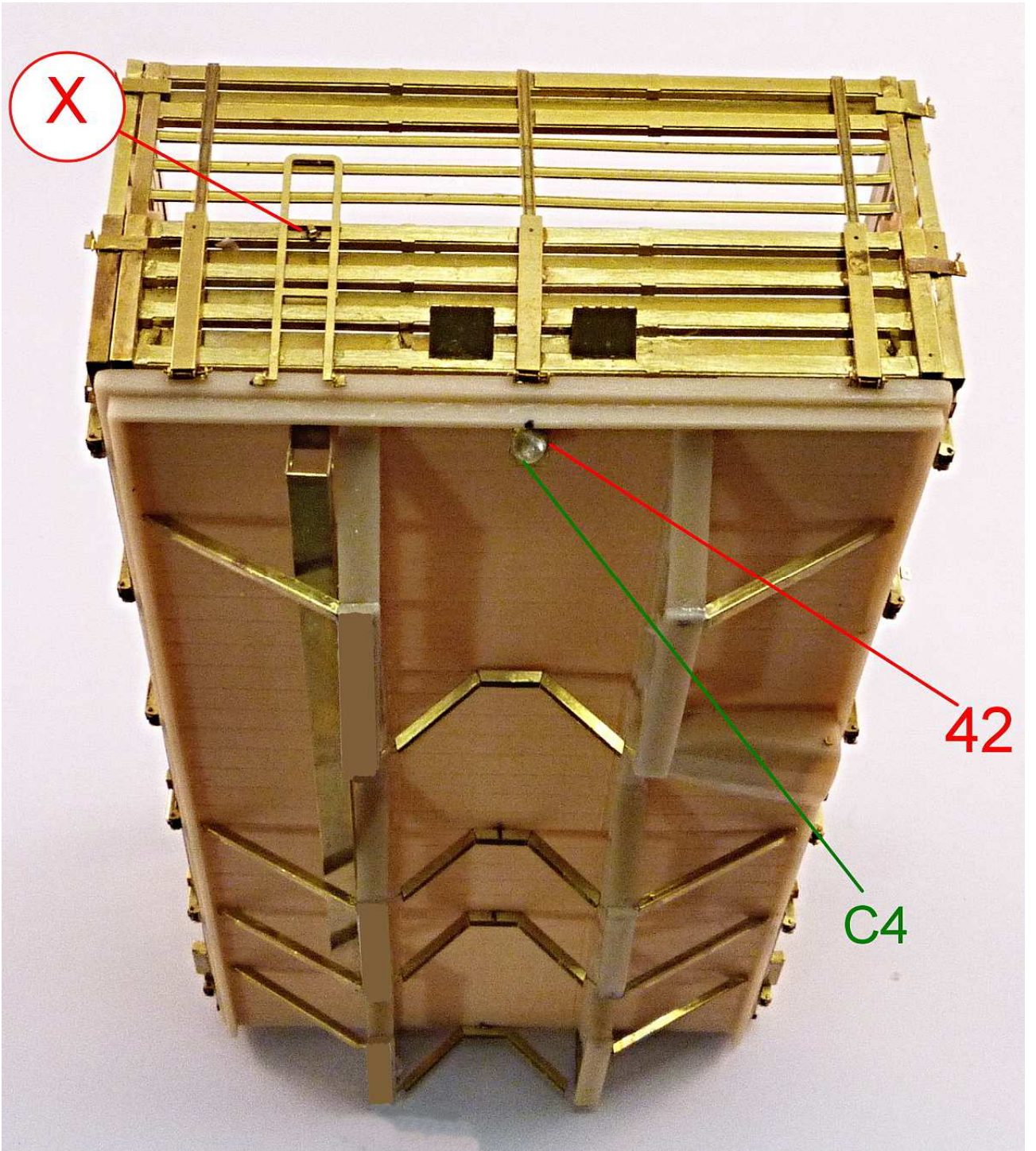



# R SIDE

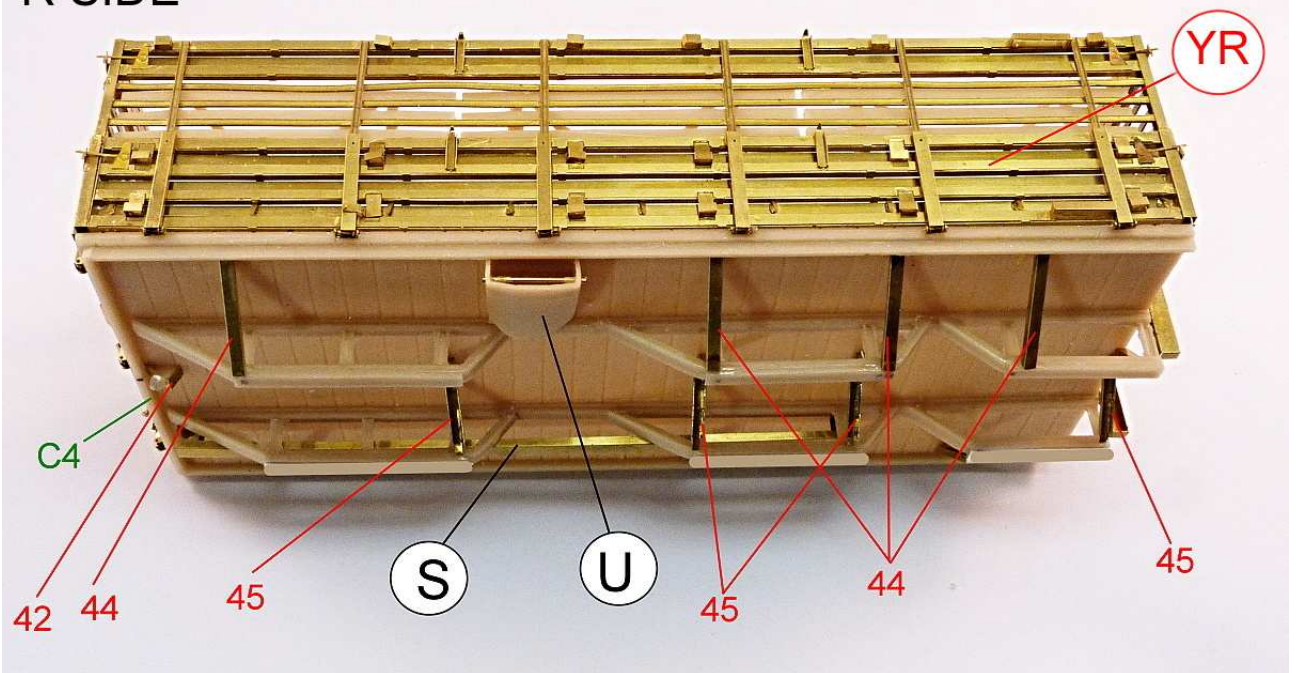

# L SIDE

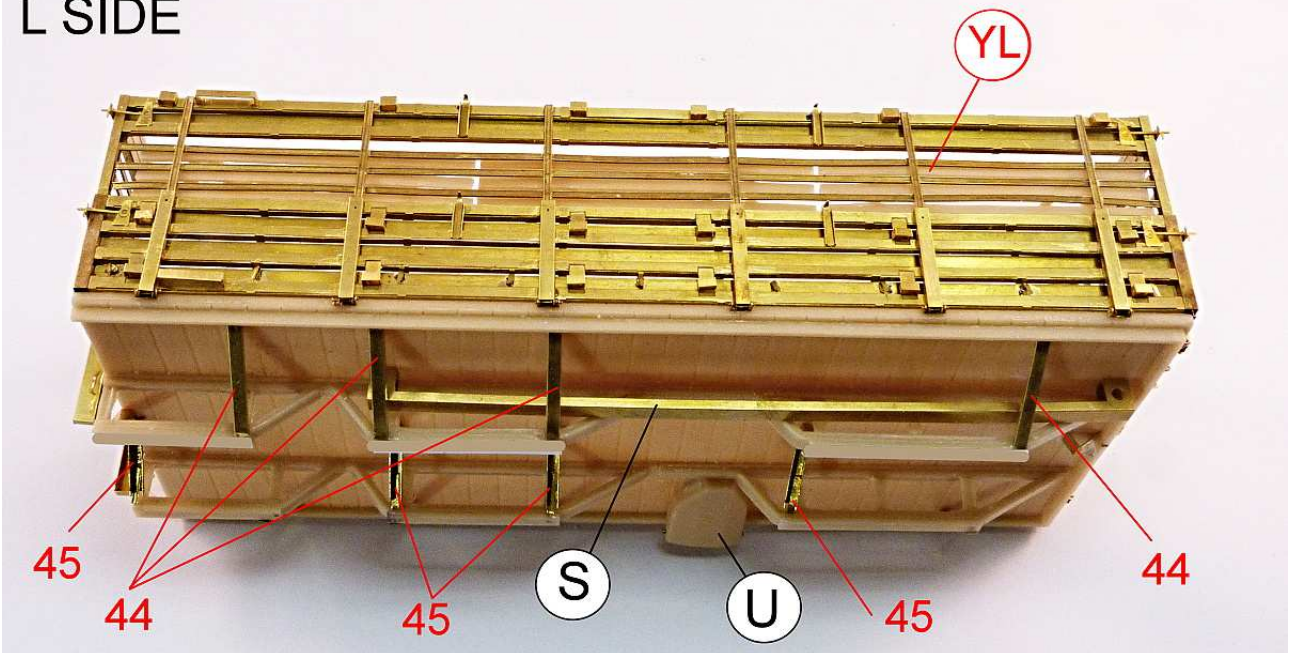

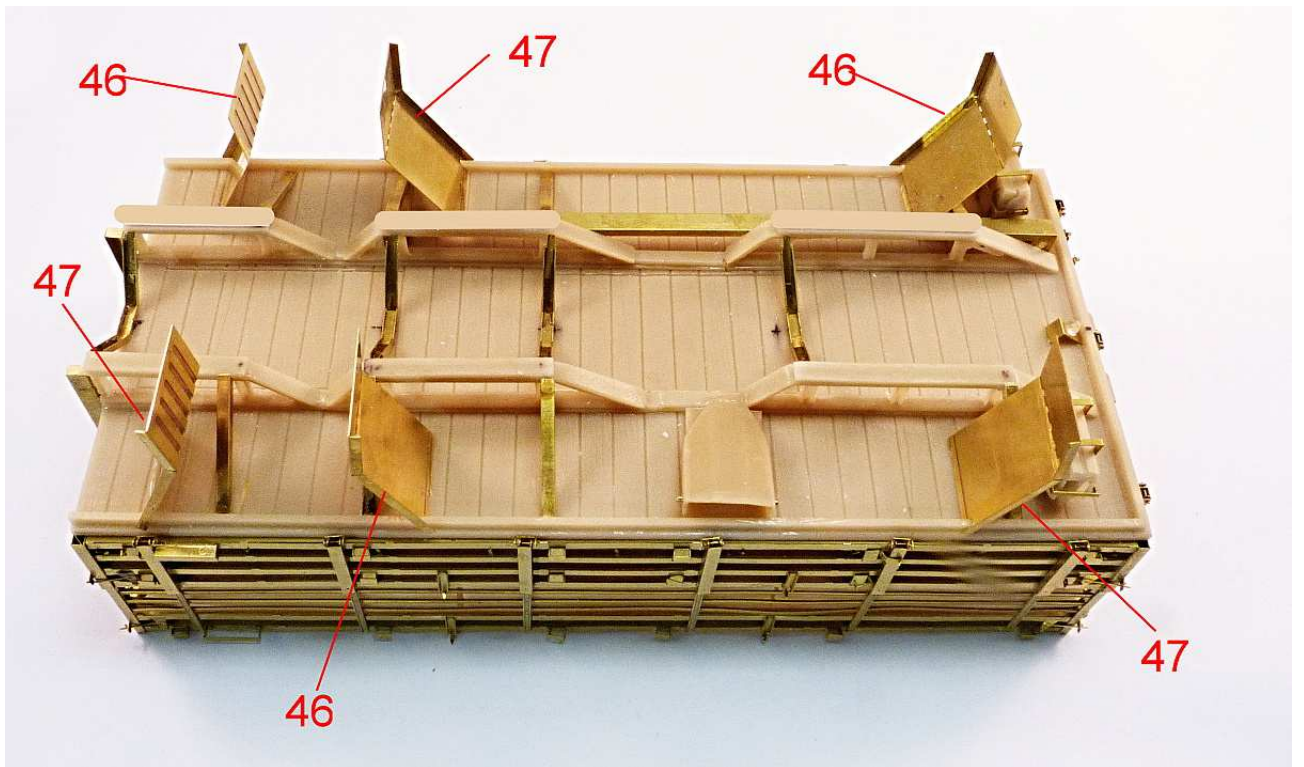
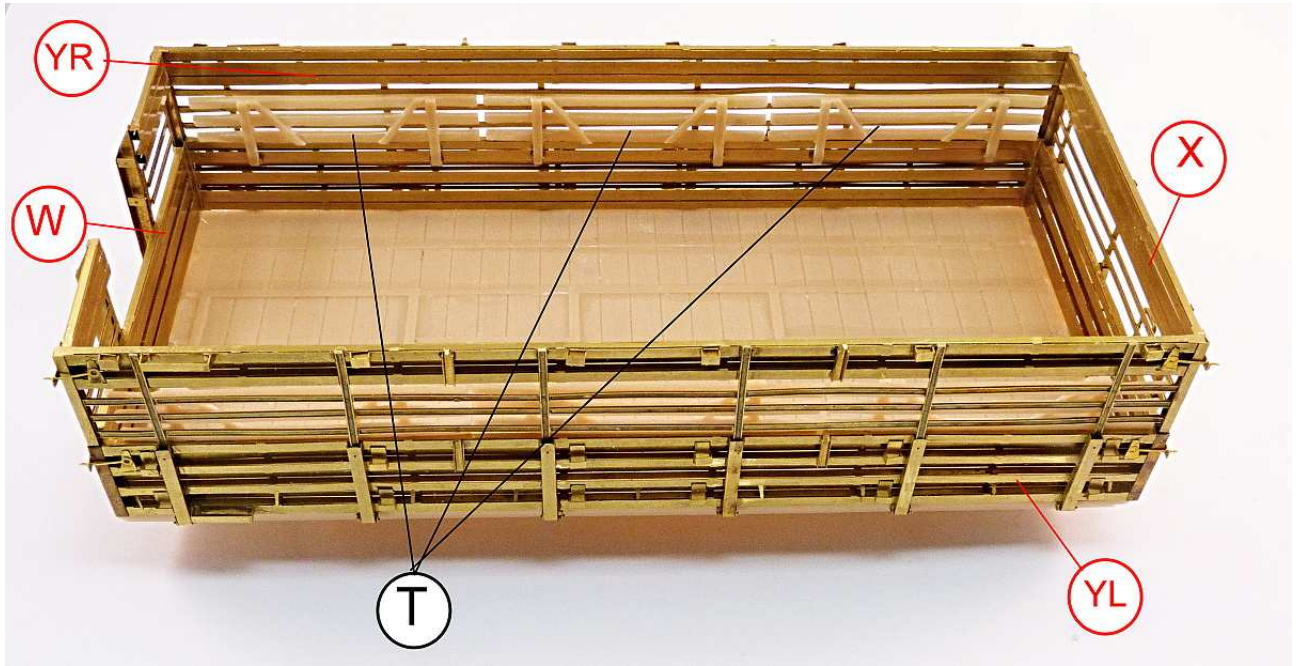

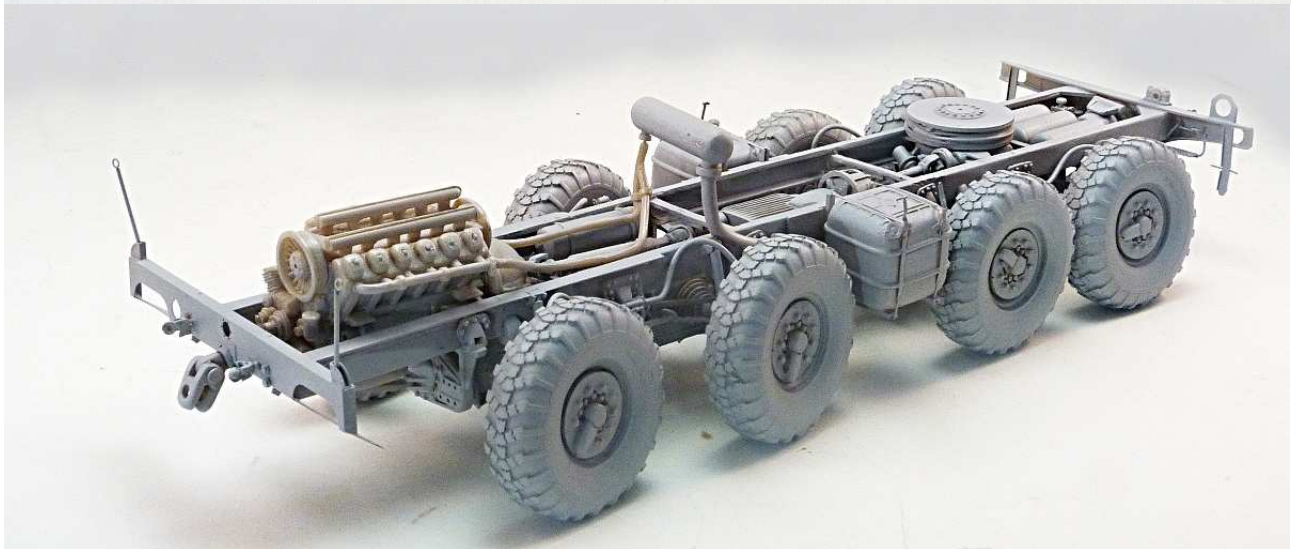
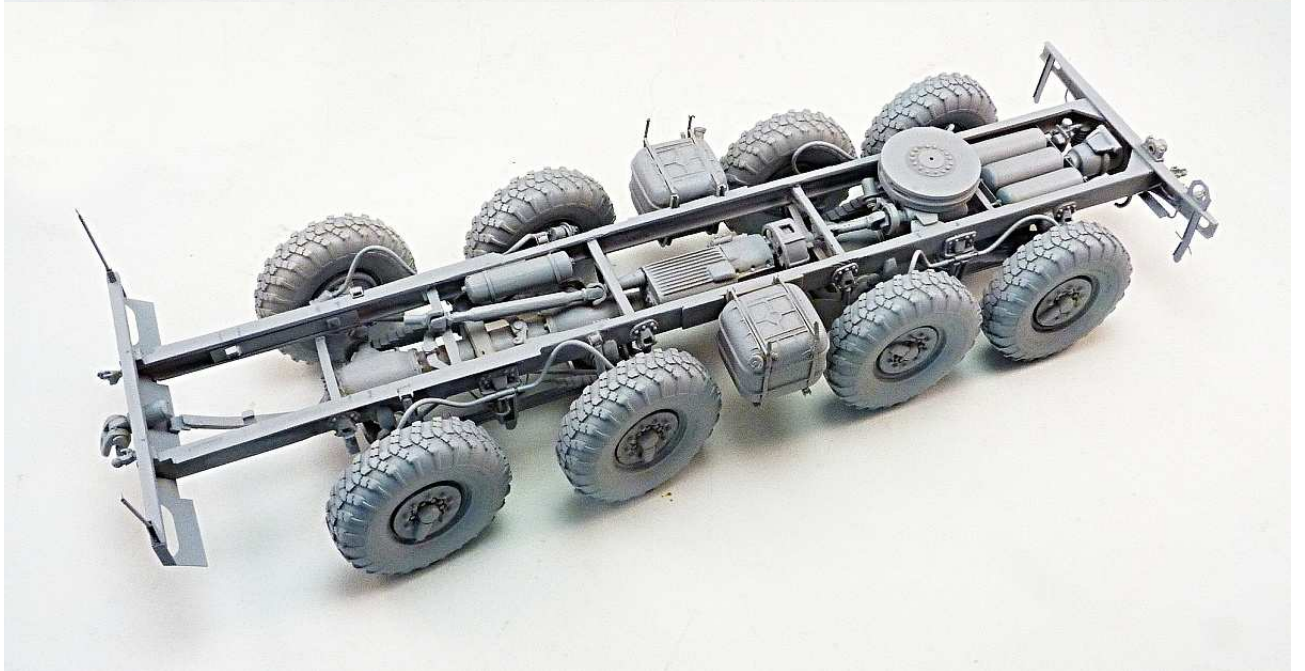
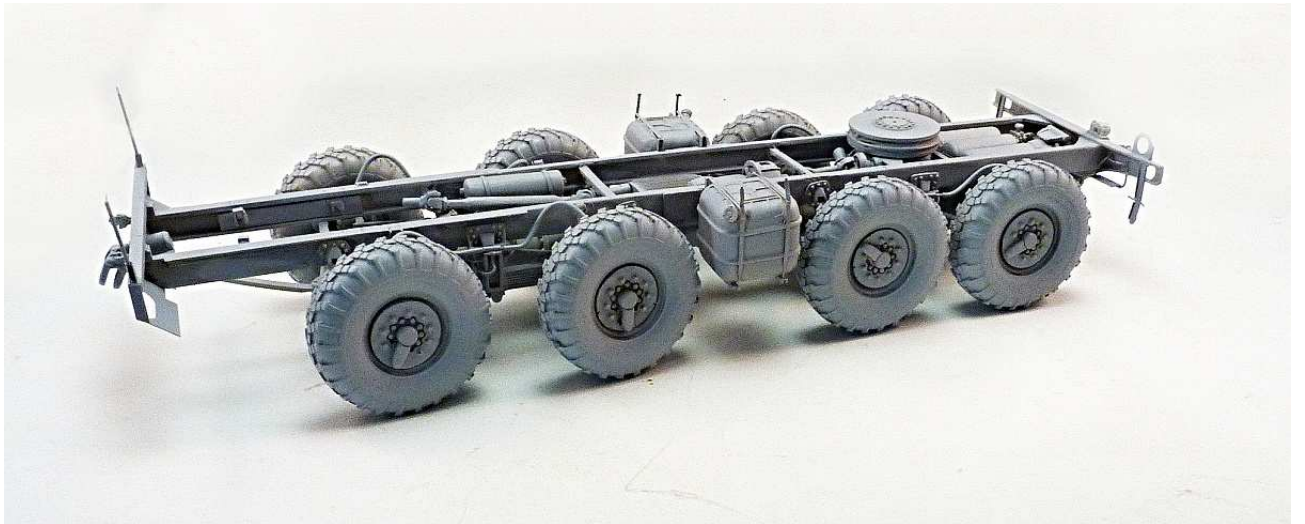















MMK Folknáře 70 40501 Děčín [www.mmk.cz](http://www.mmk.cz) [mk.model@volny.cz](mailto:mk.model@volny.cz)

## MO III

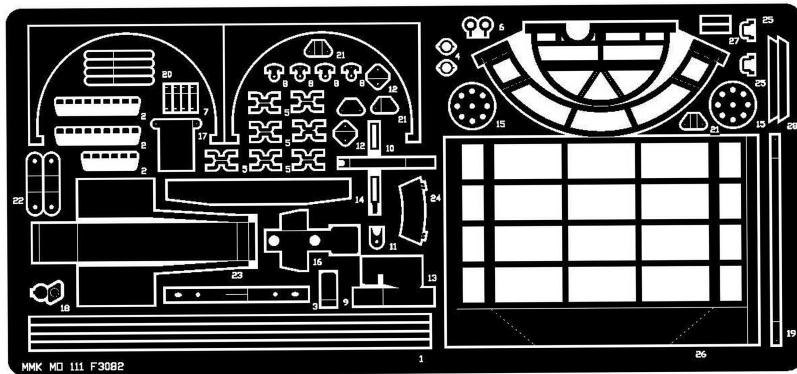

● pur parts

● photoetched parts

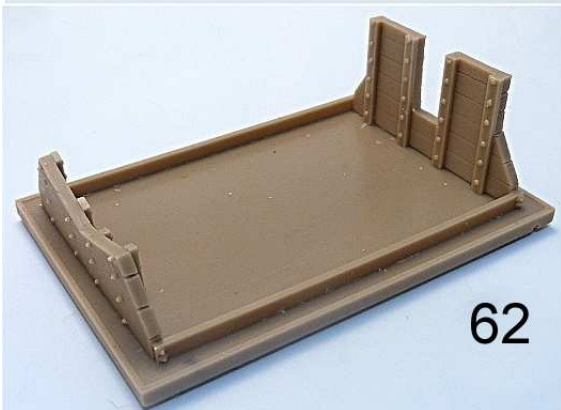

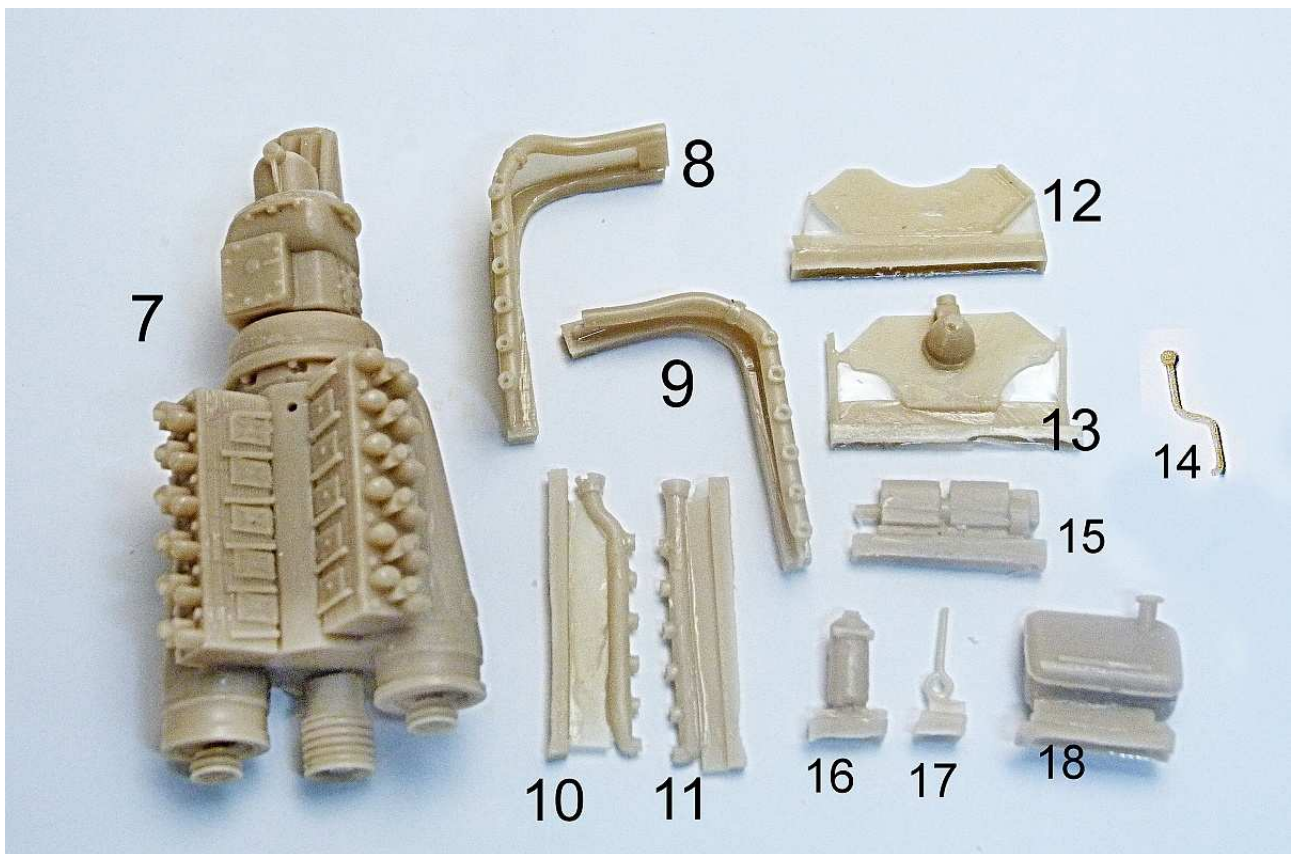
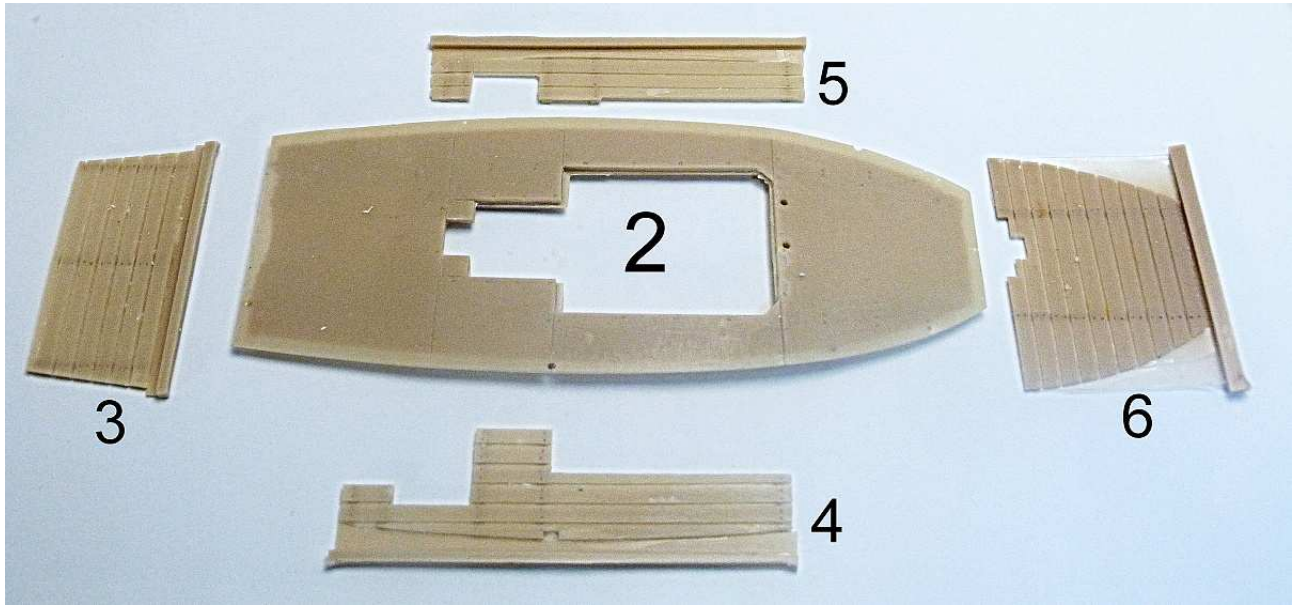



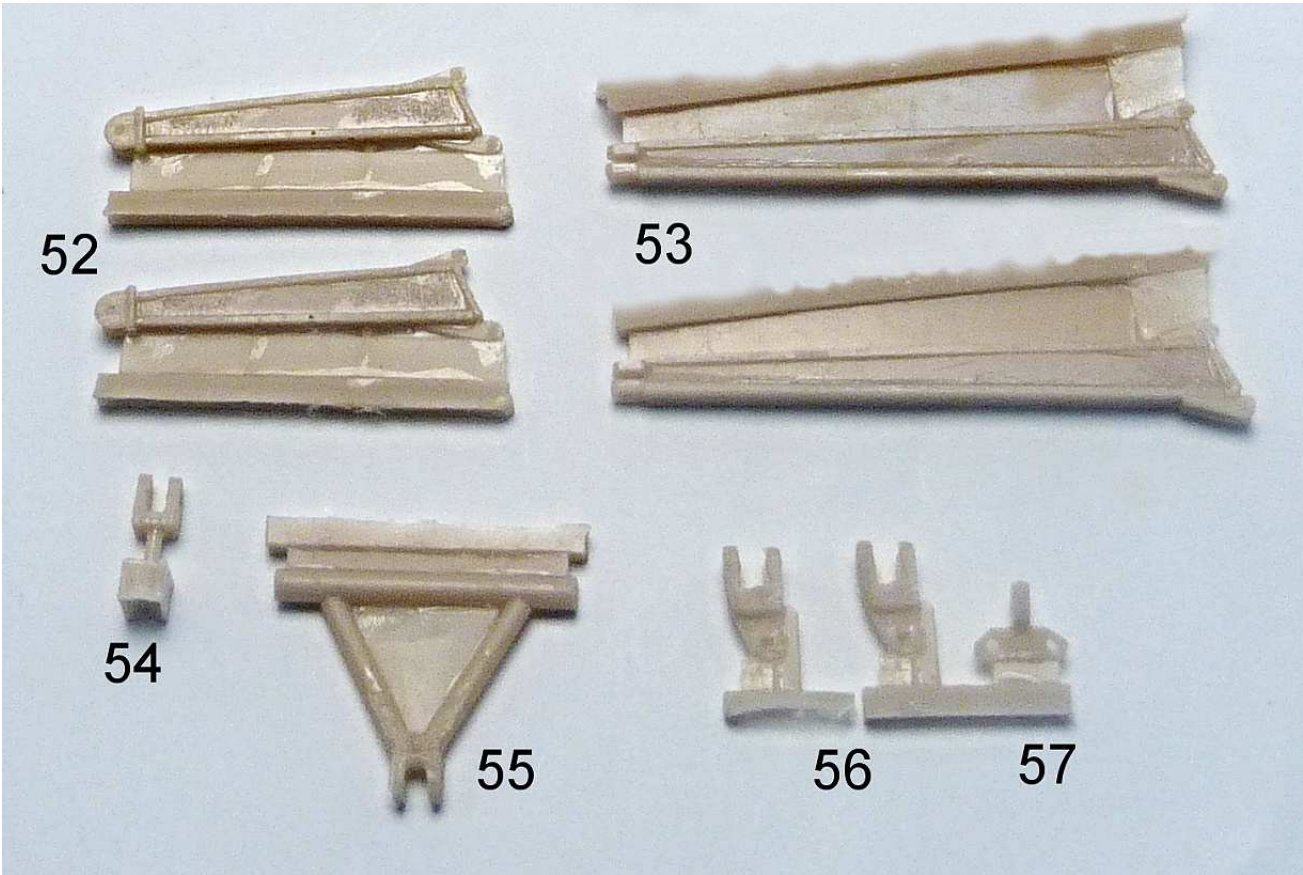
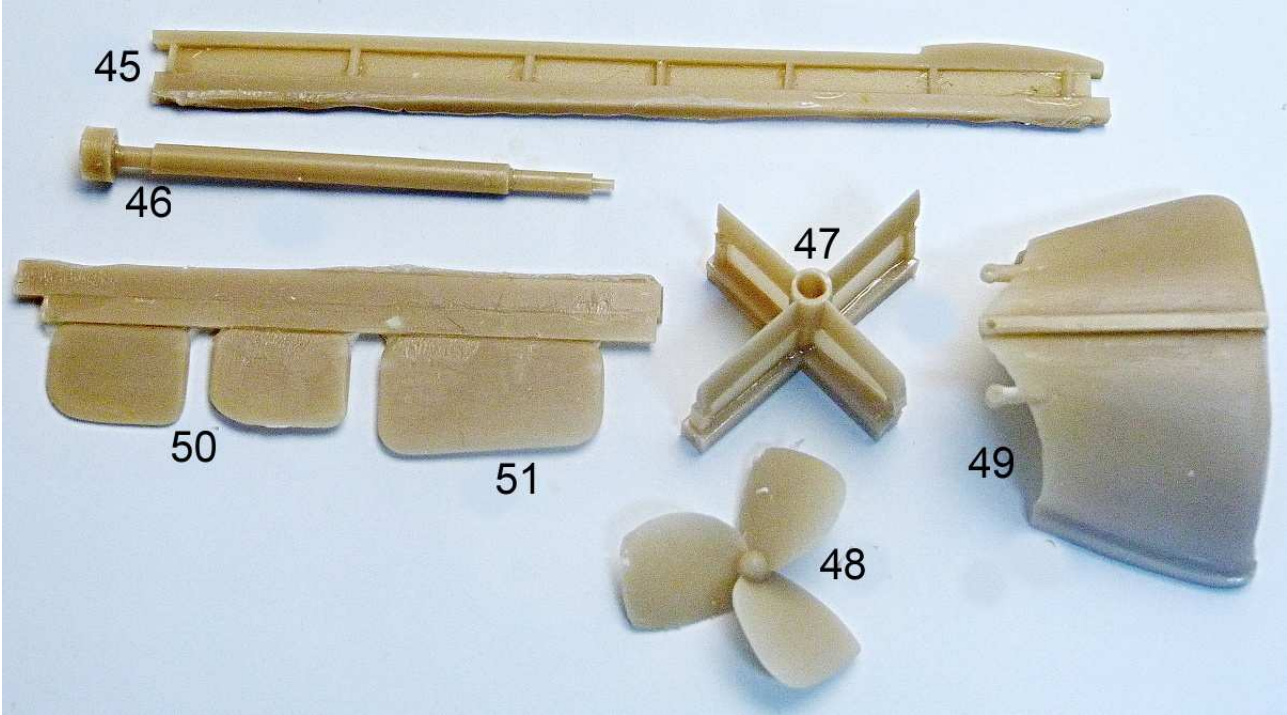

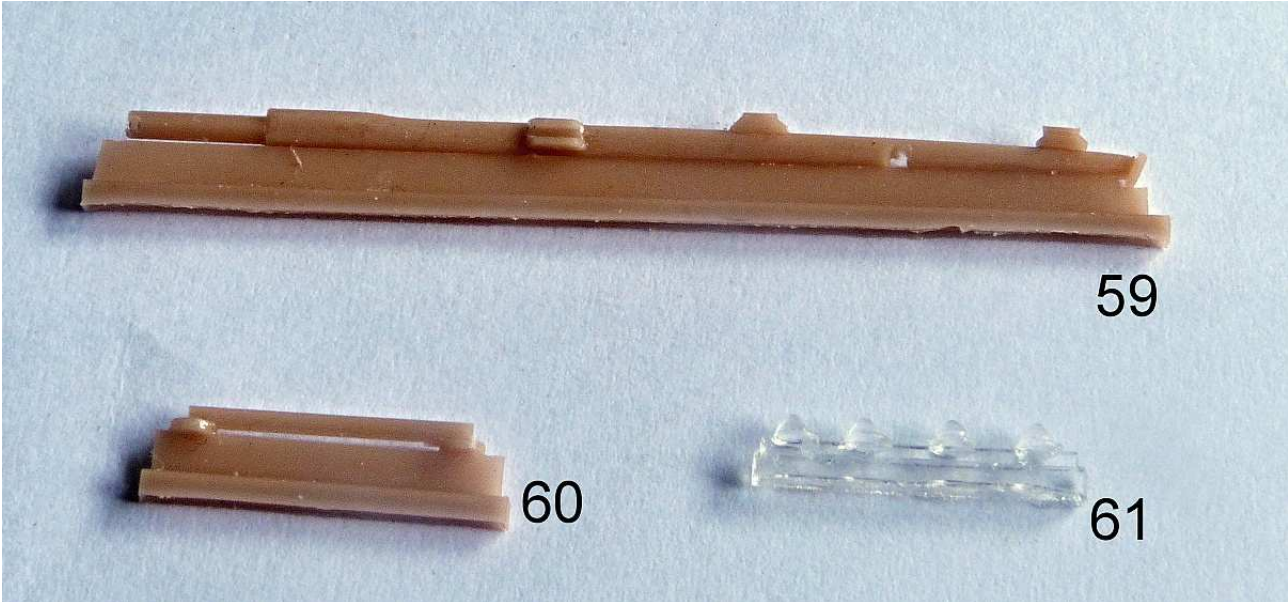

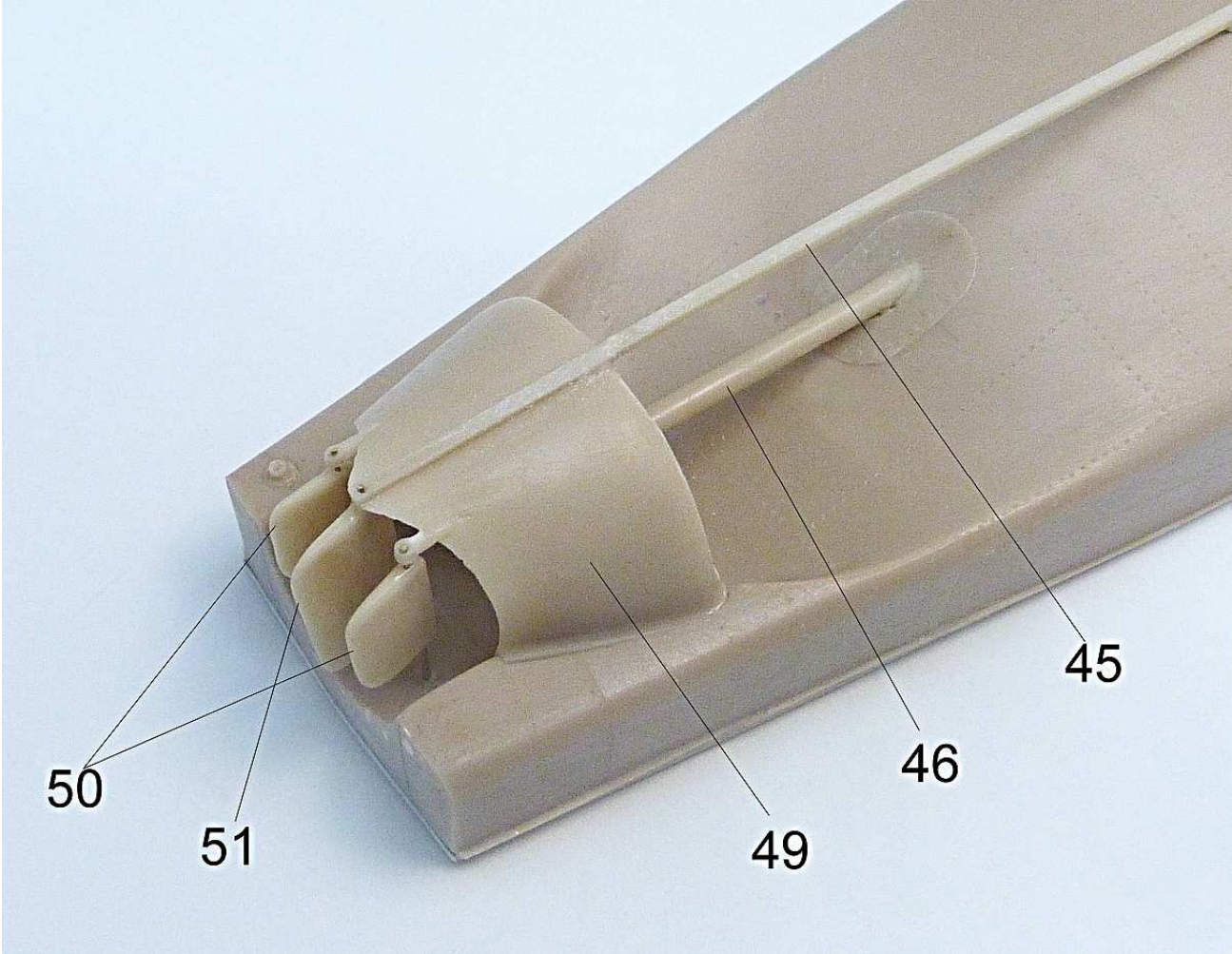

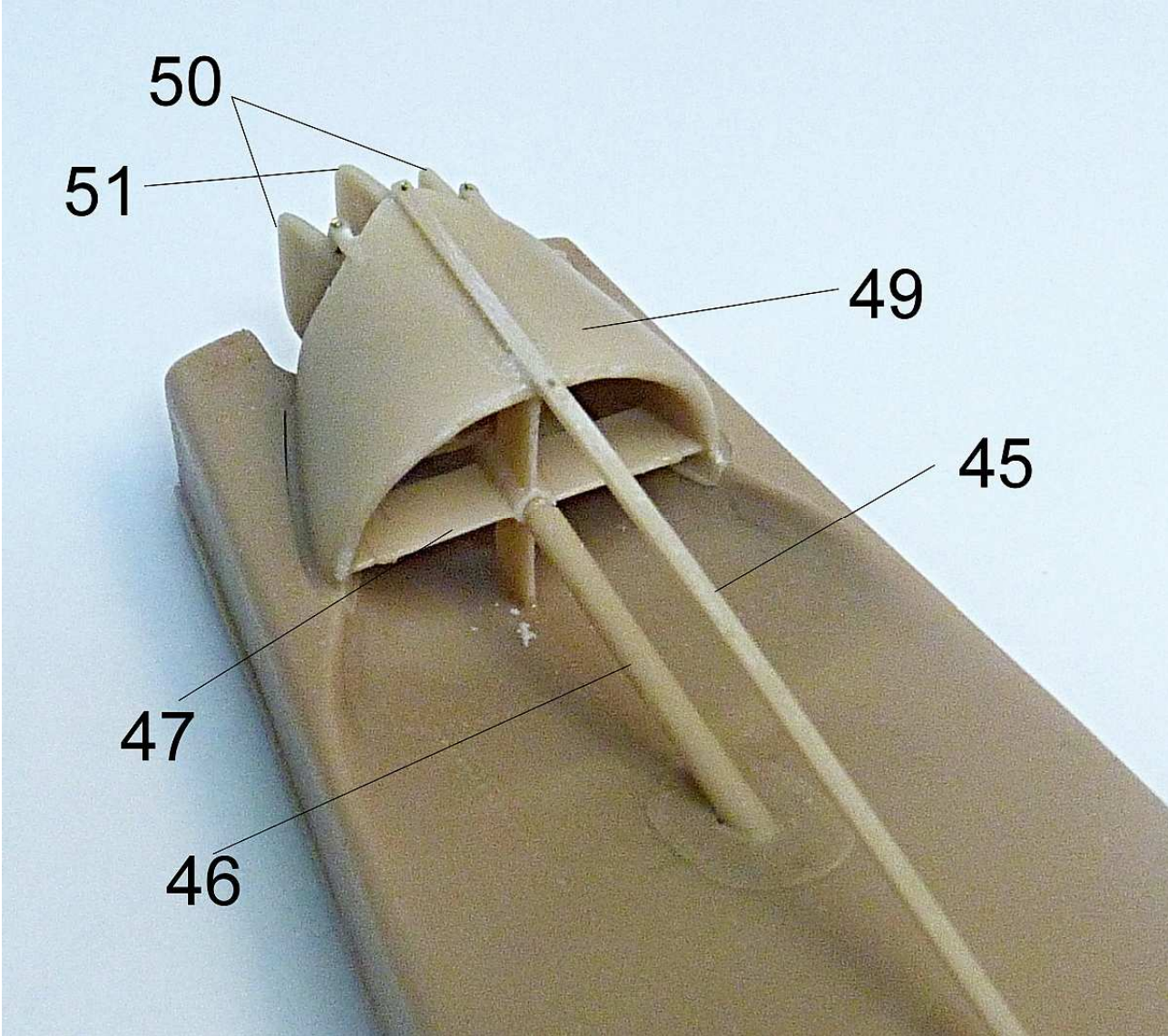

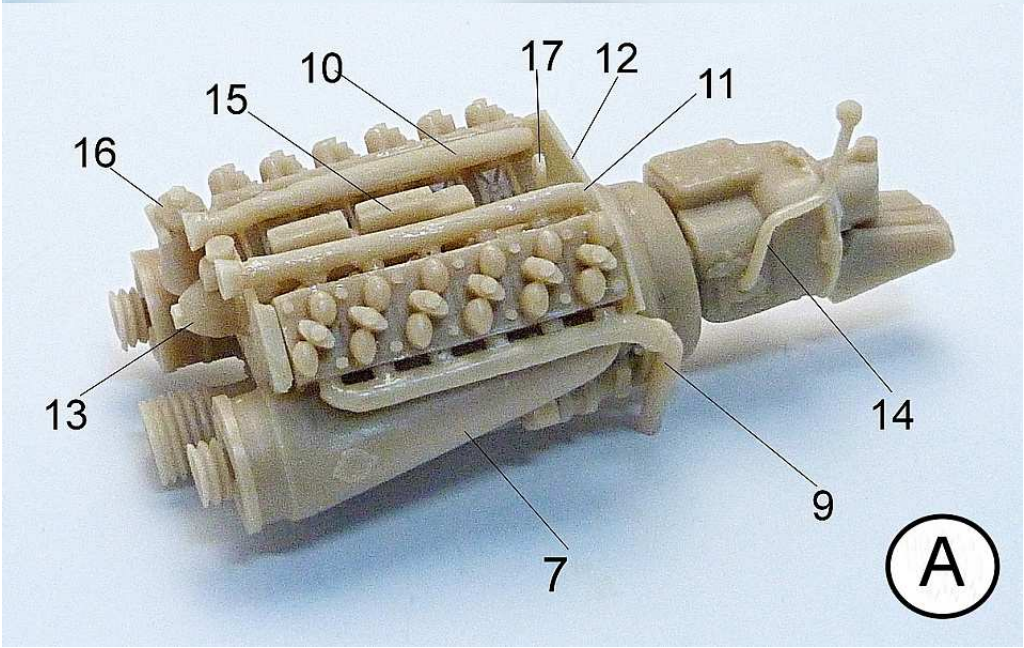
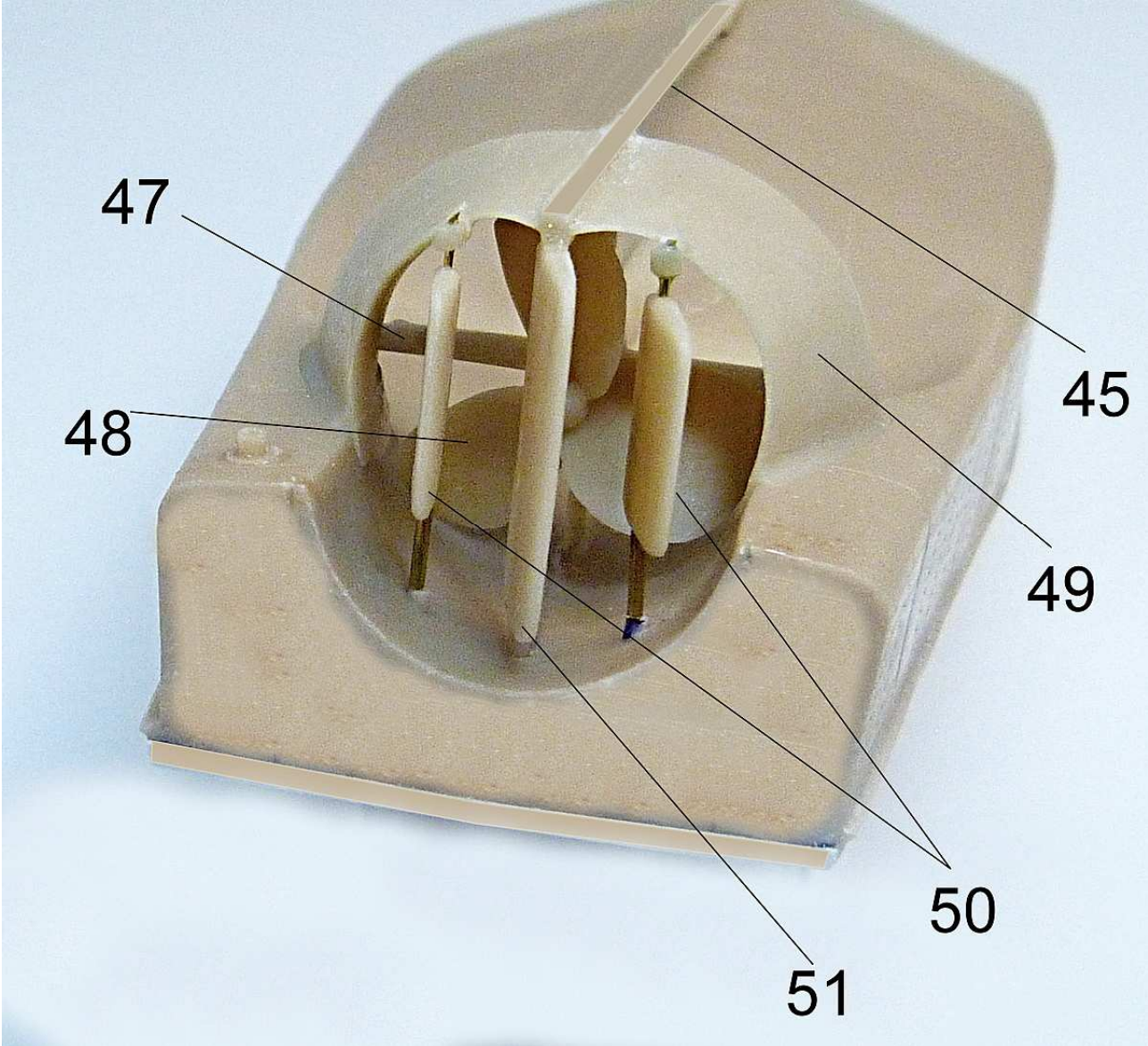



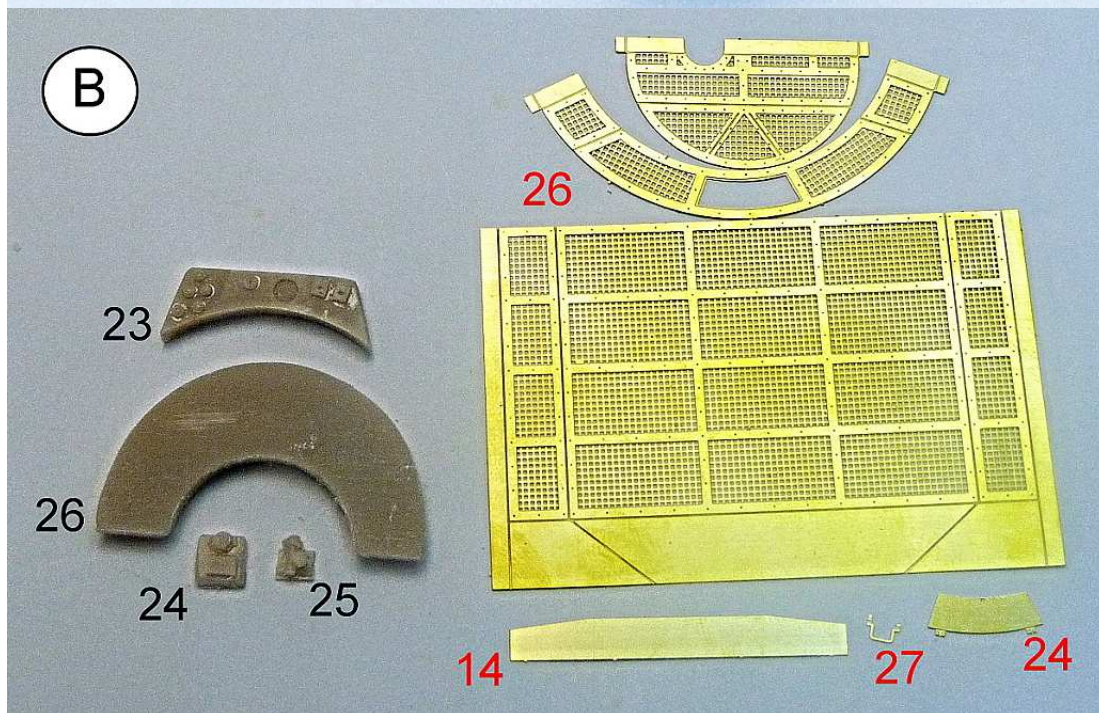
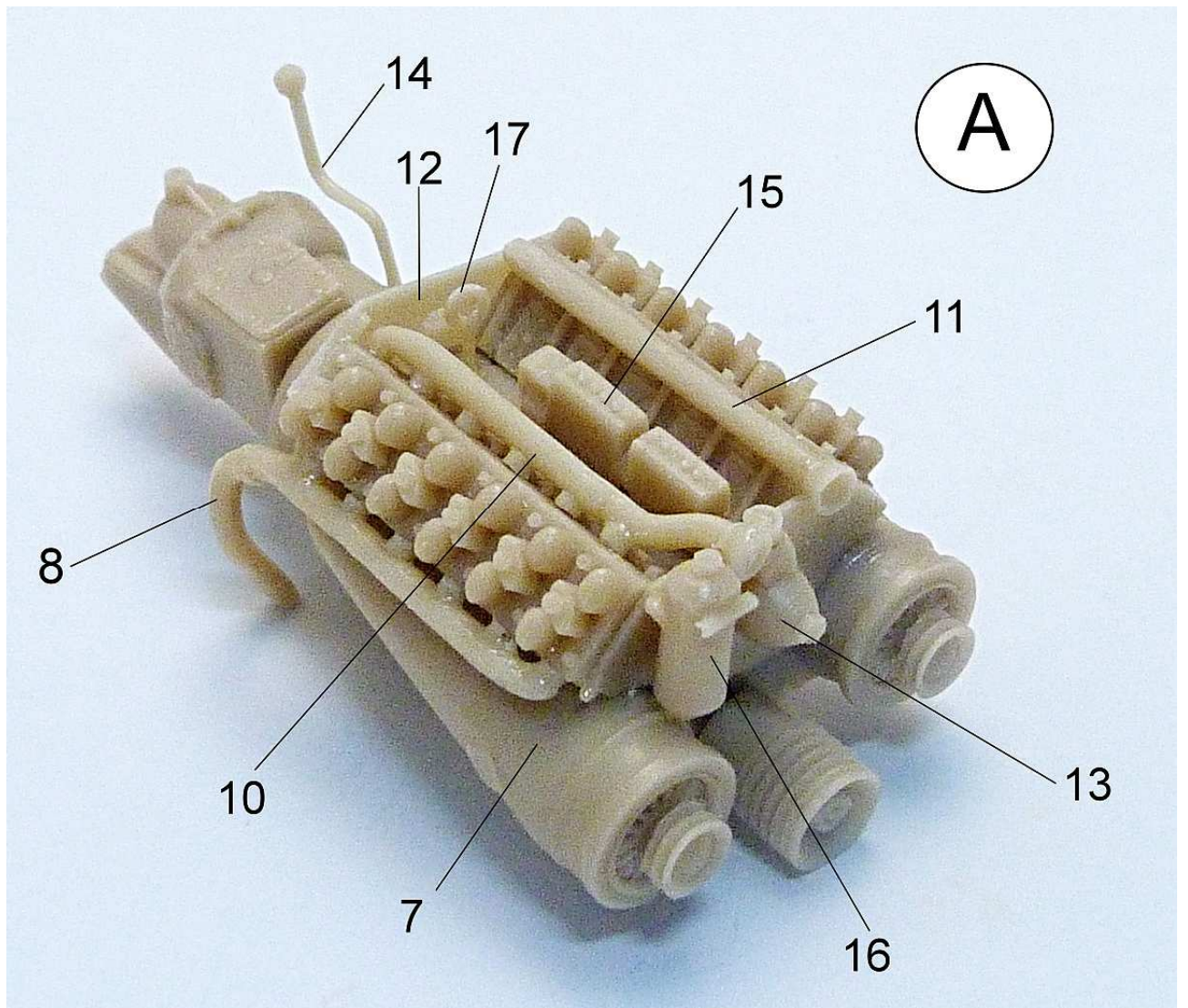

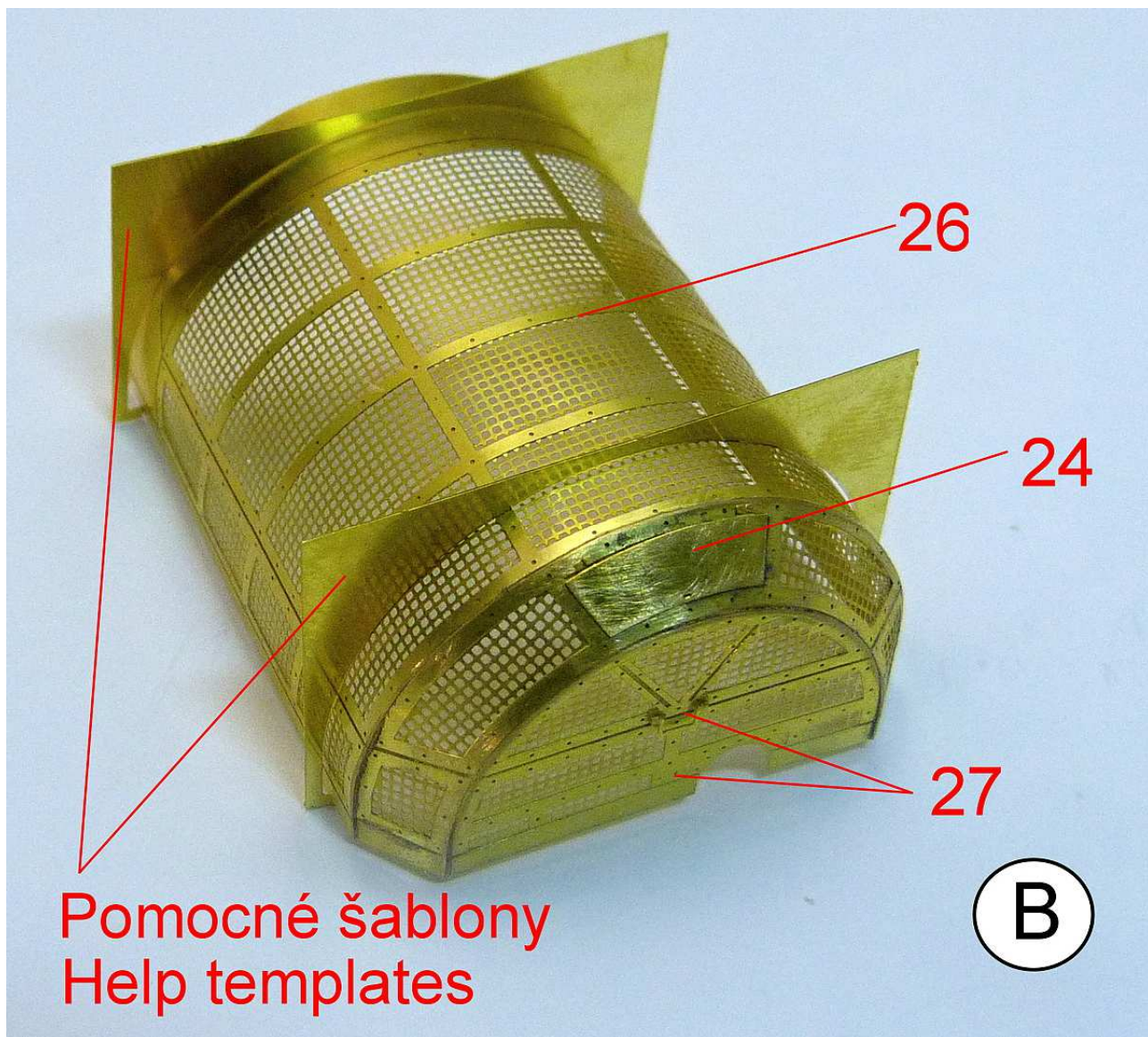

Pomocné šablony  
Help templates

B

**B**

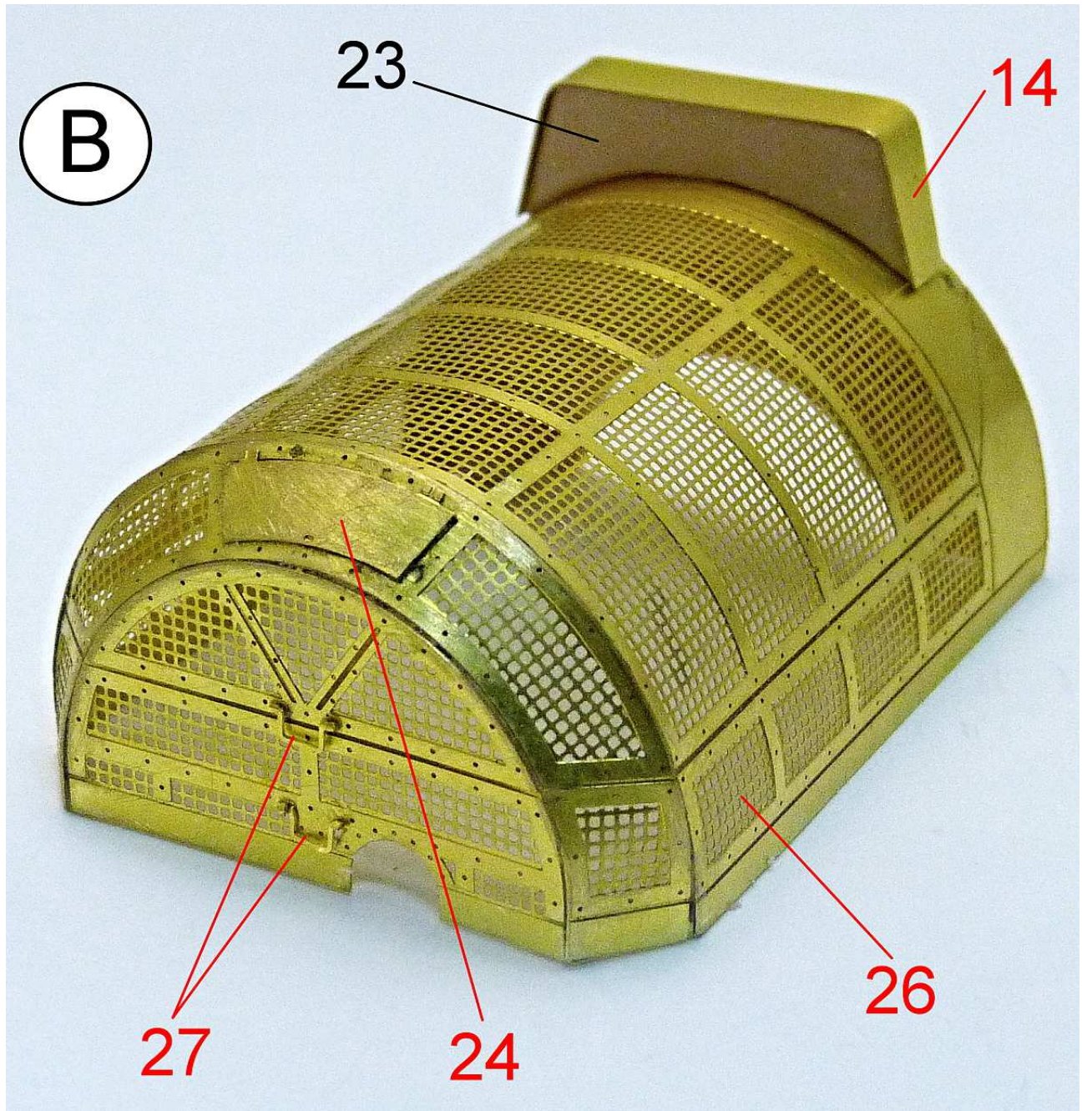

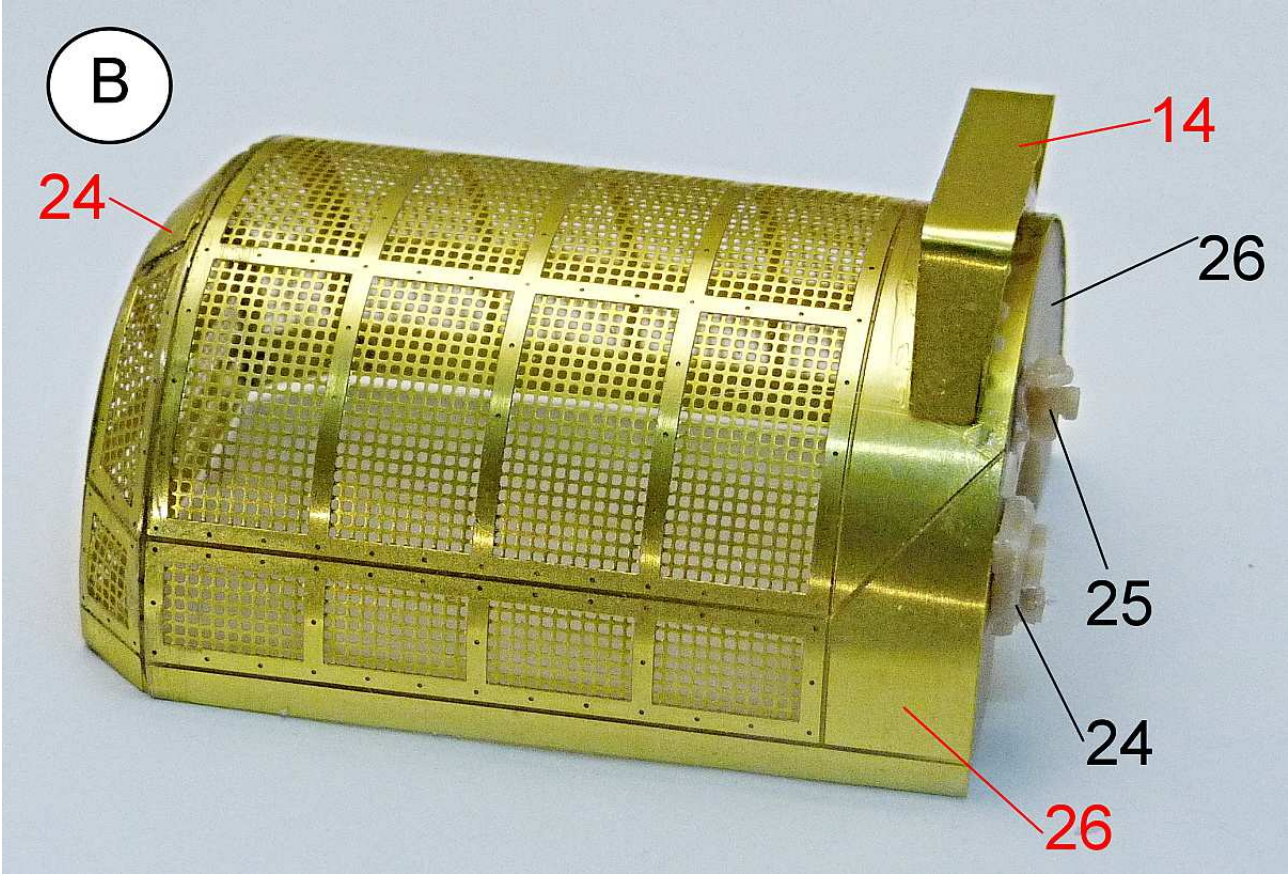

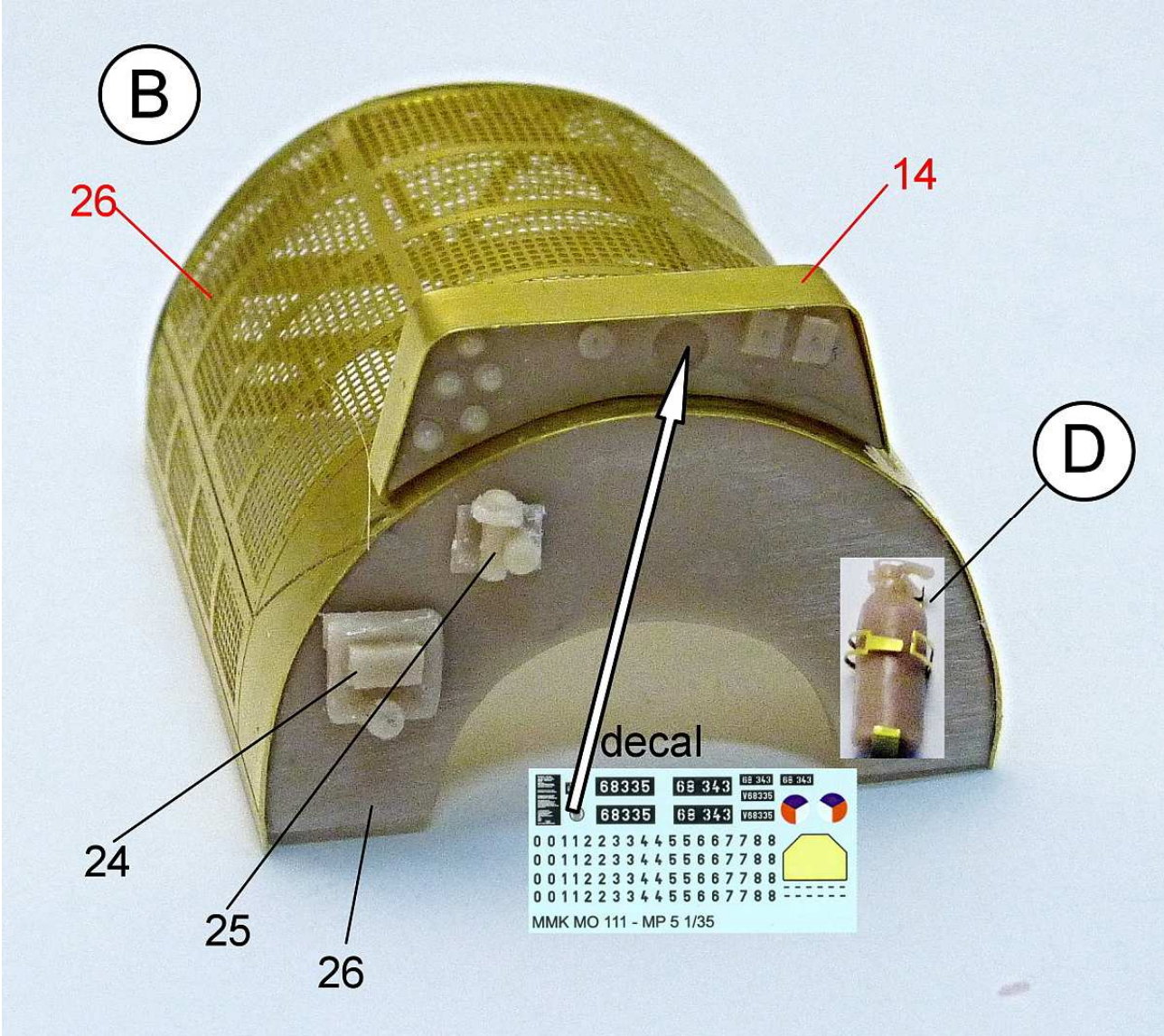

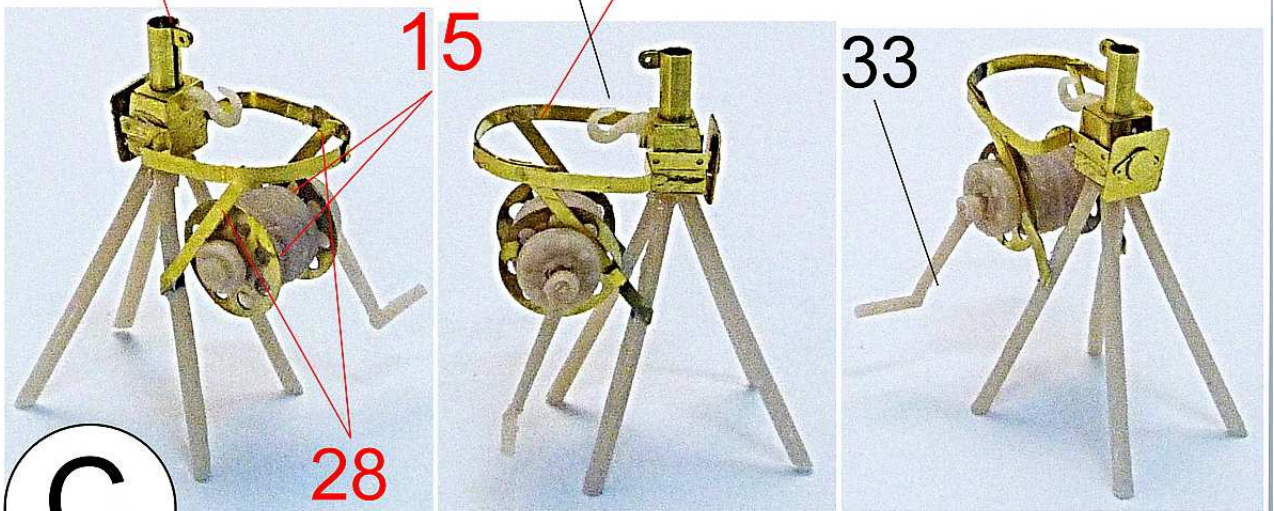
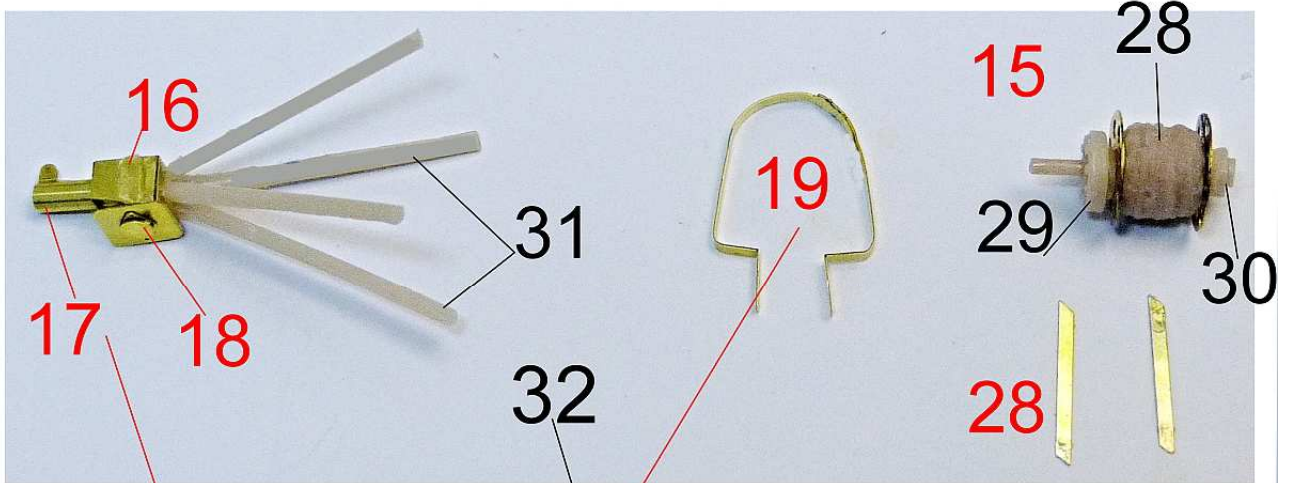
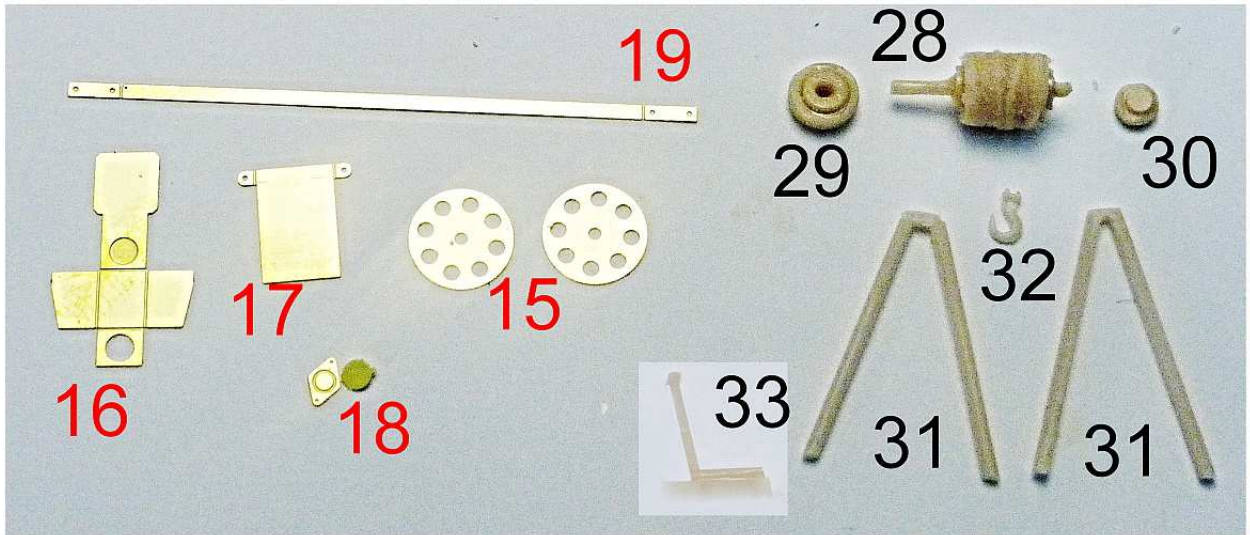

**C**

C+I

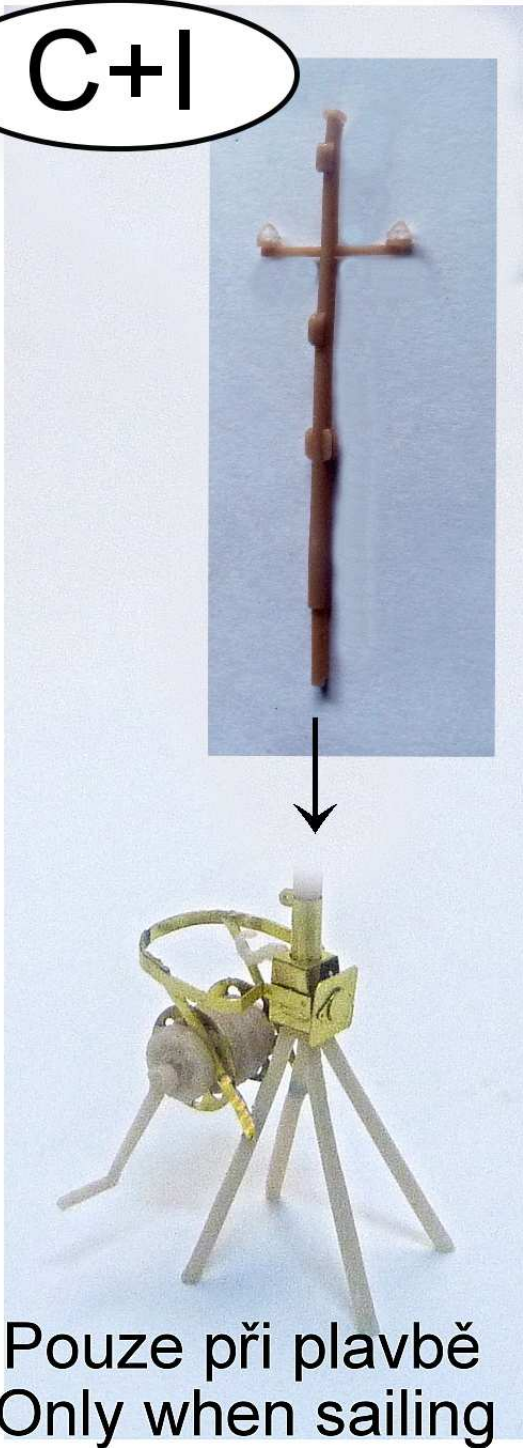

E

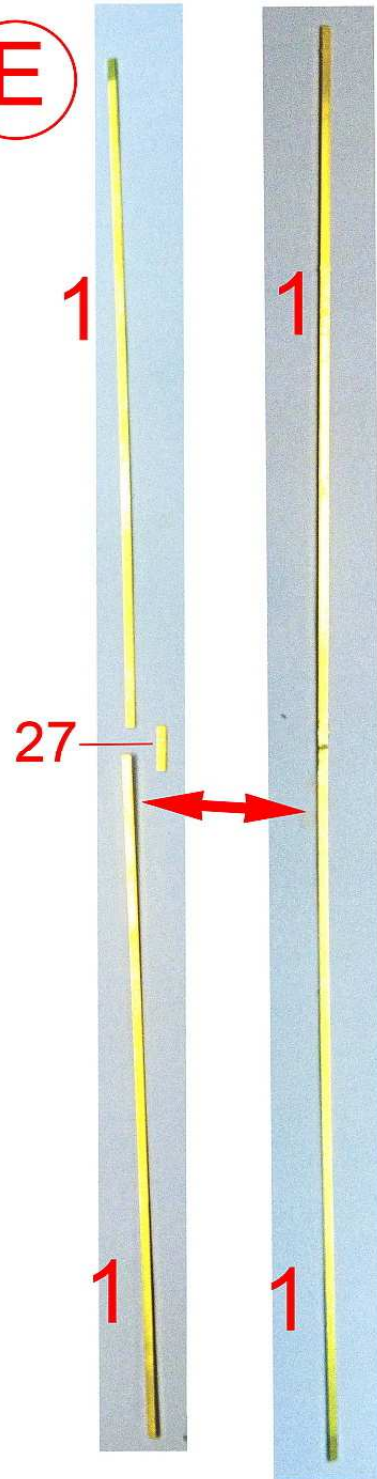

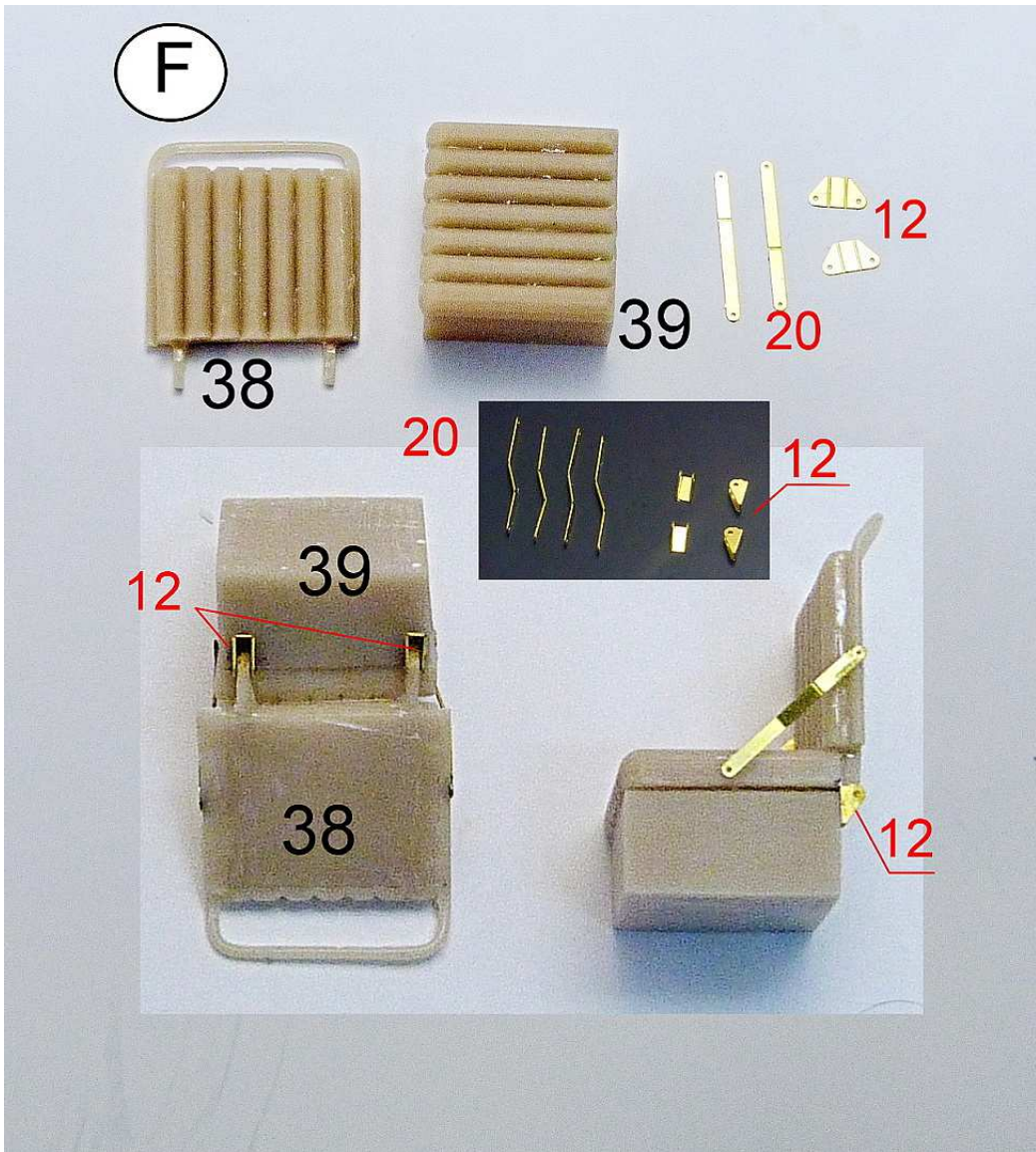
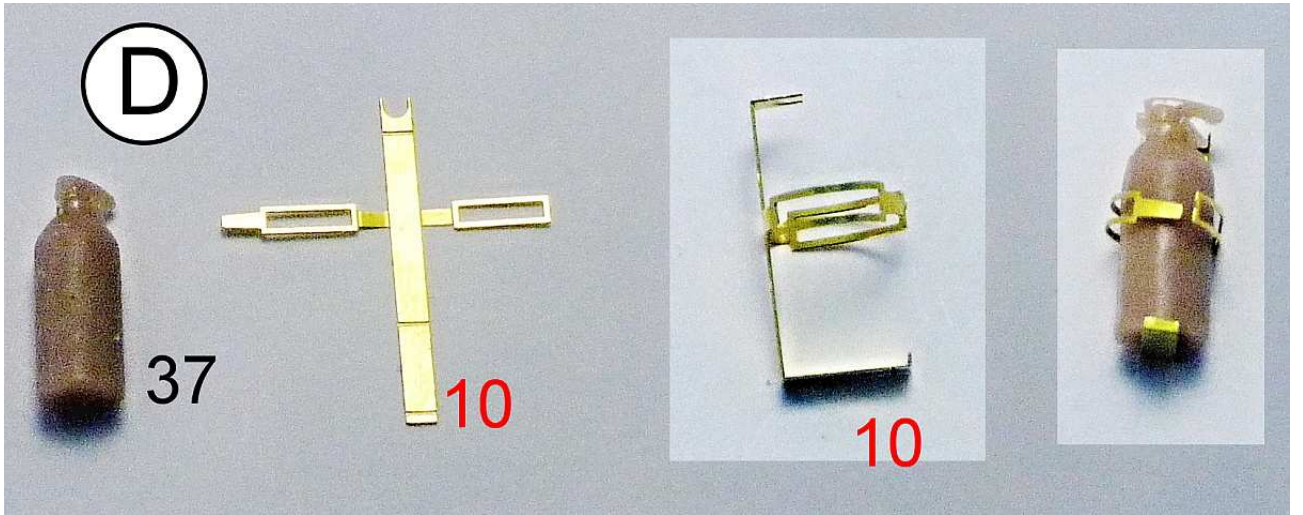



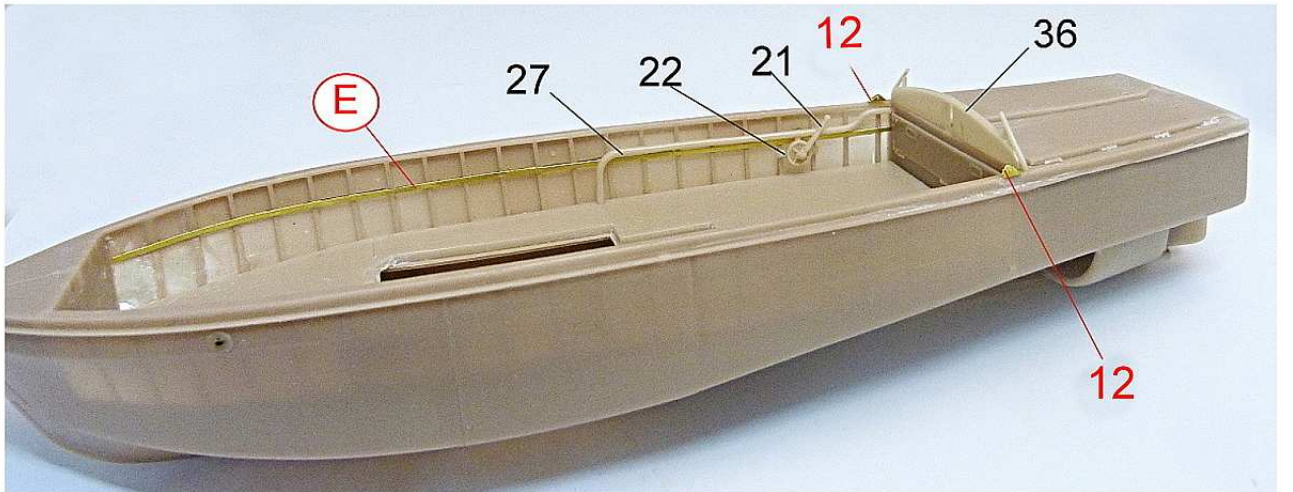
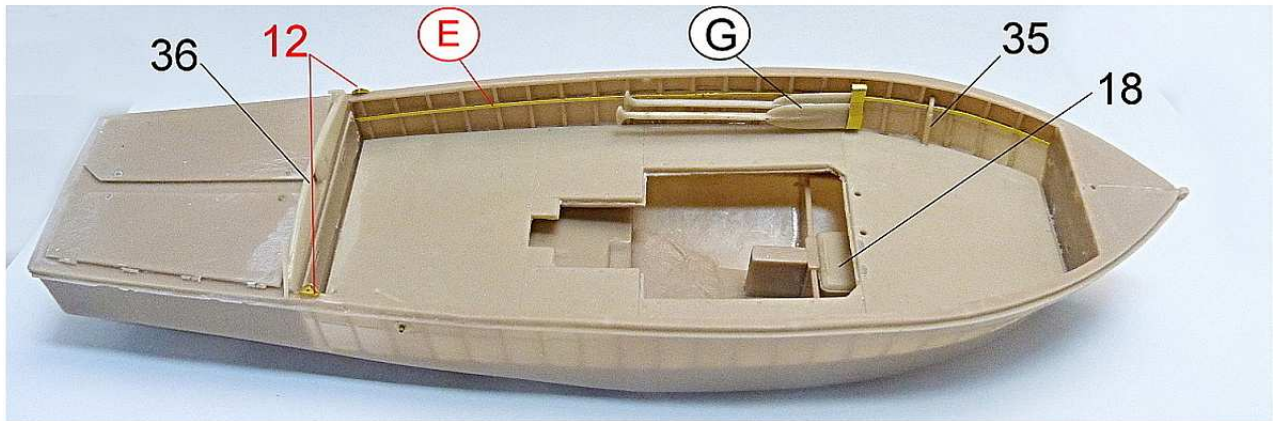
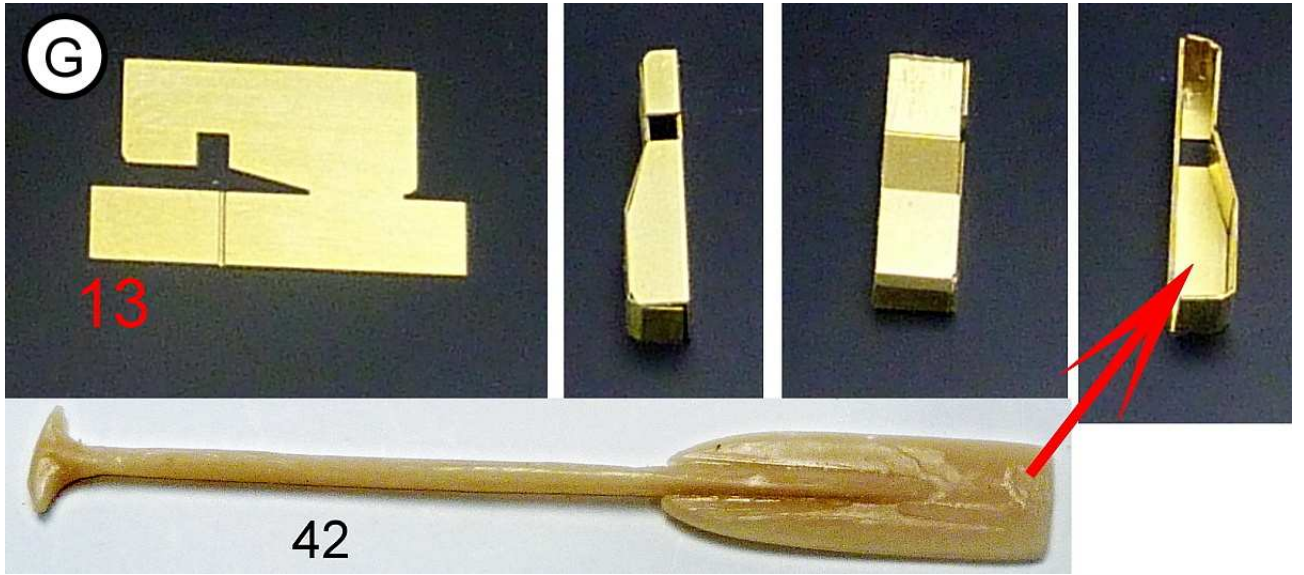

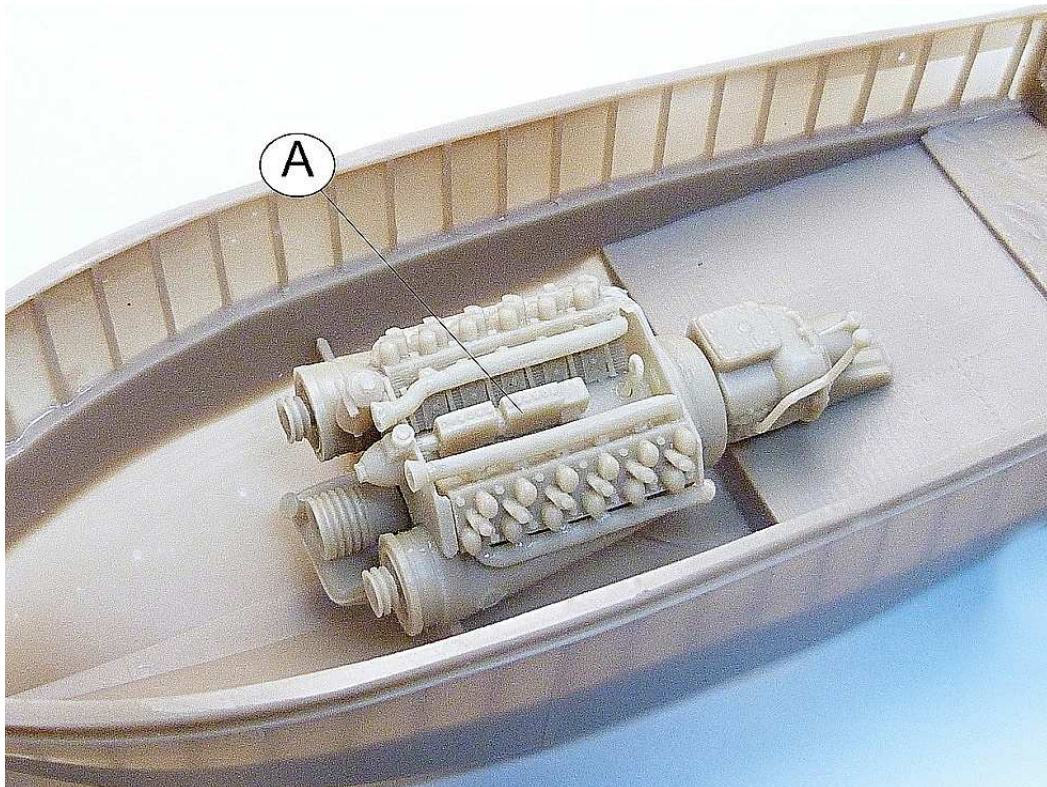
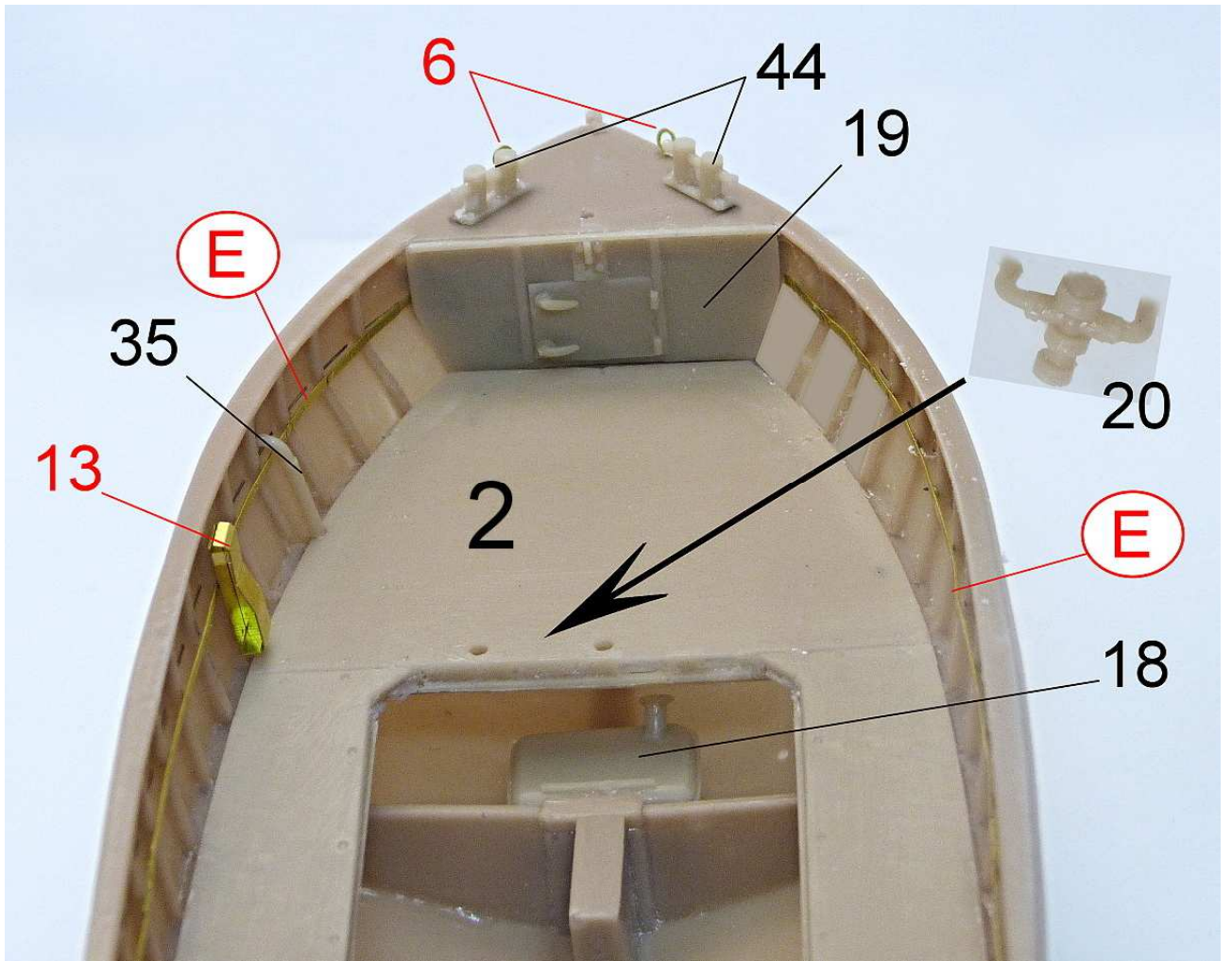

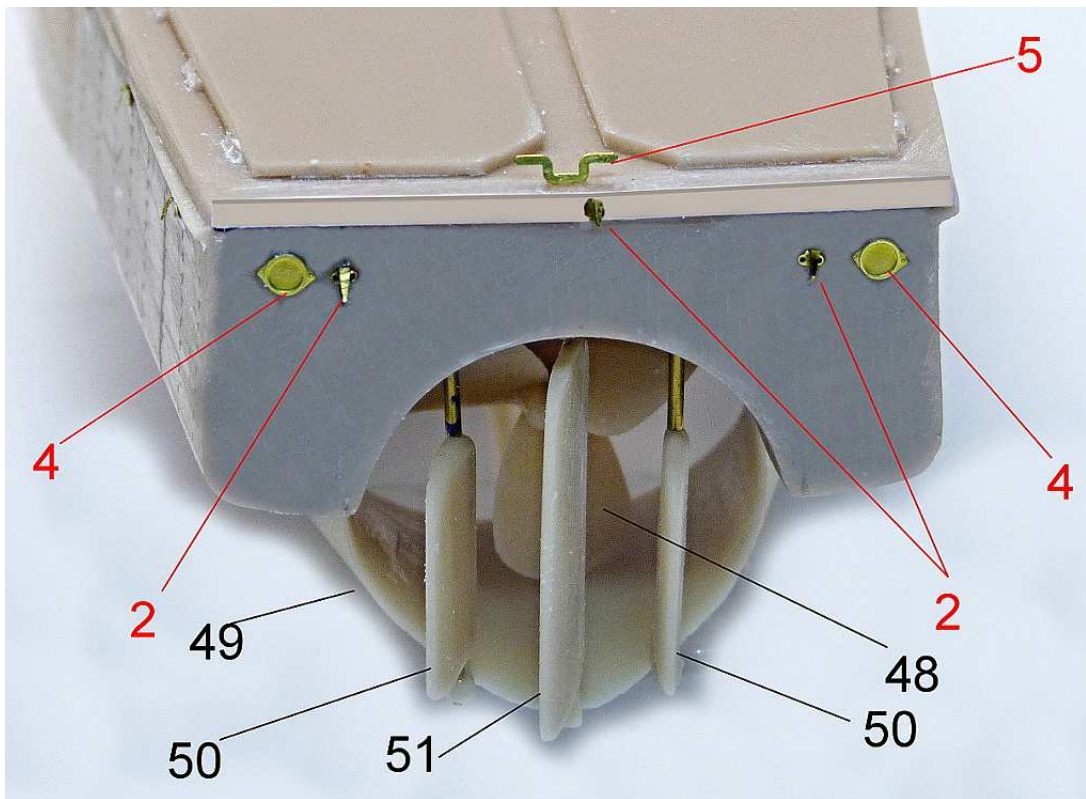
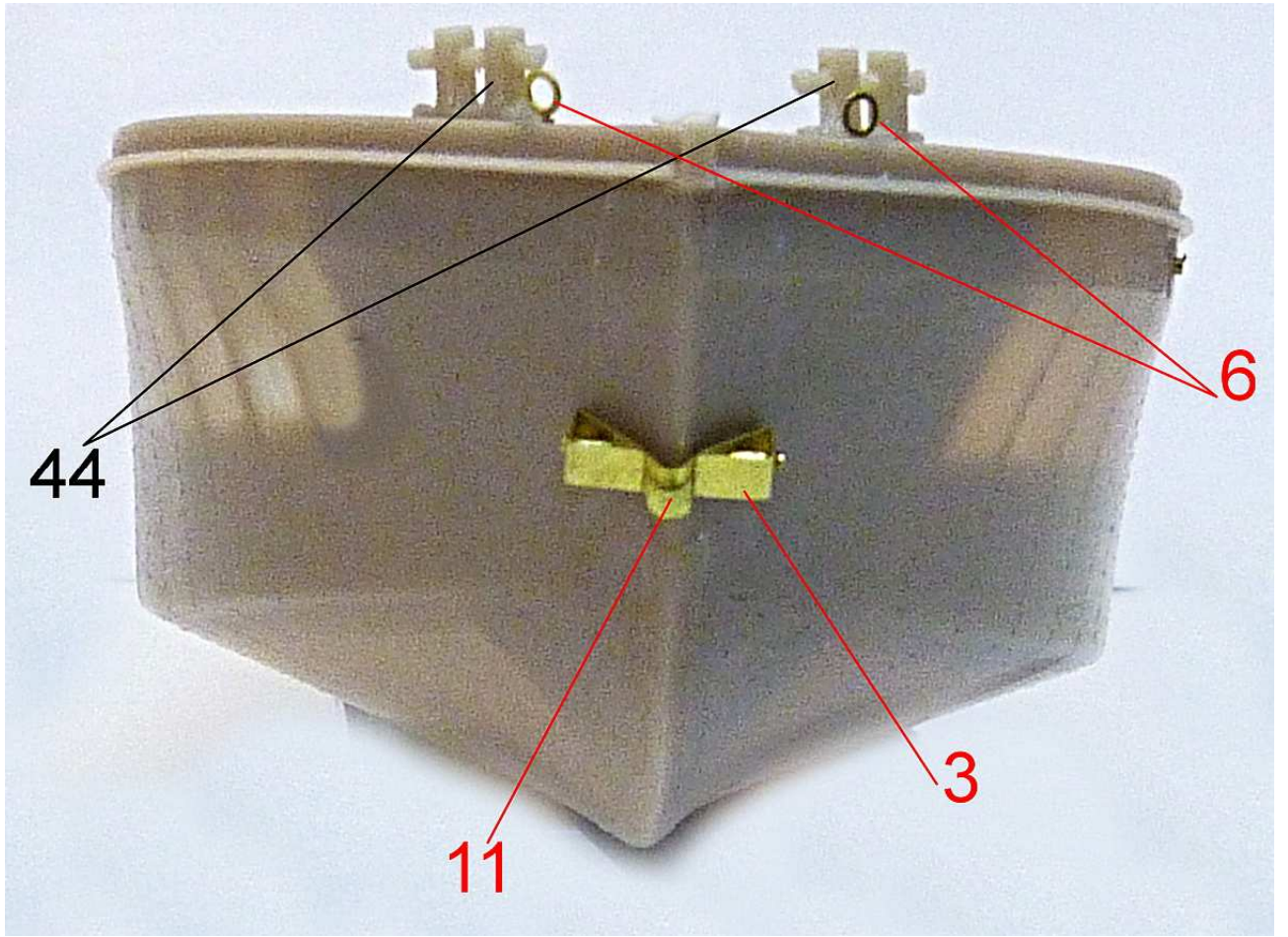

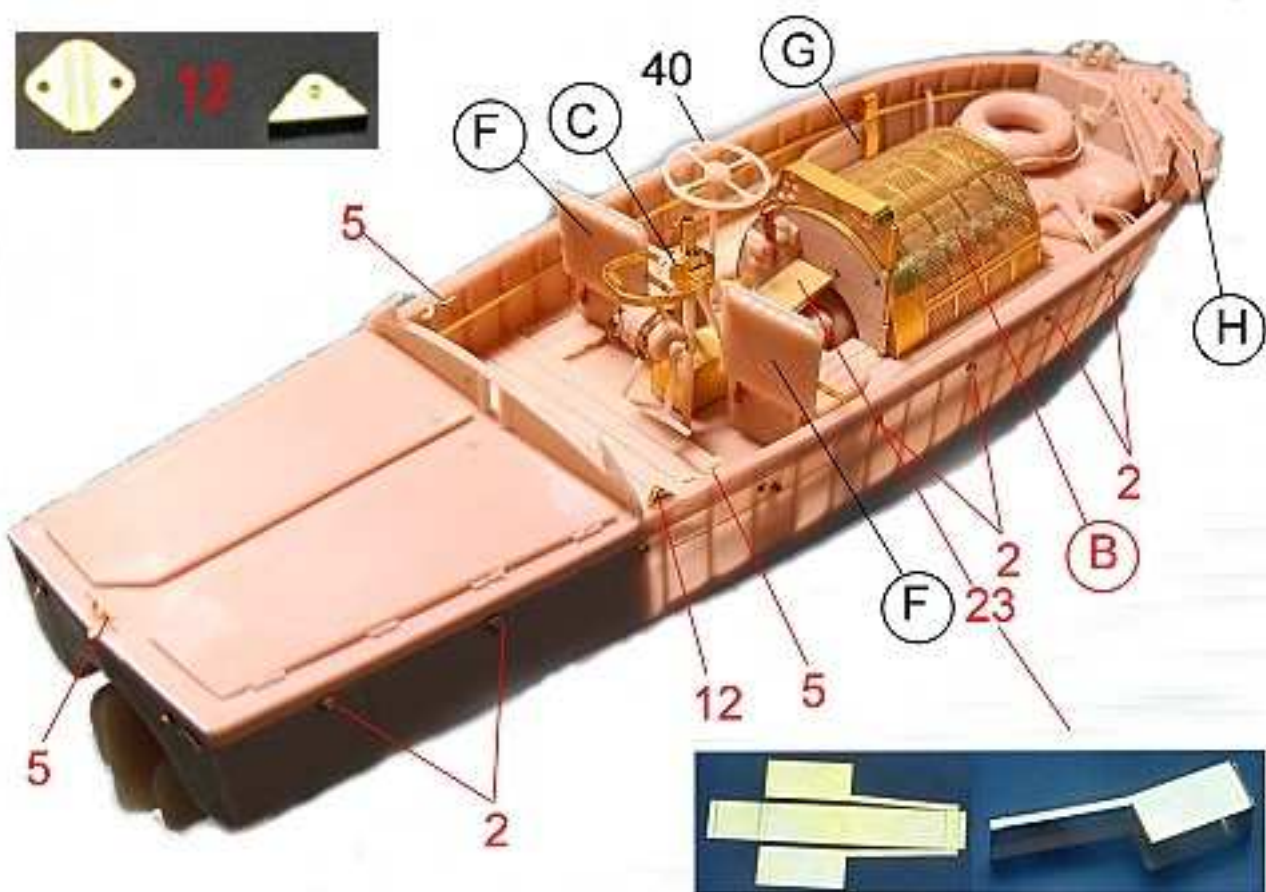
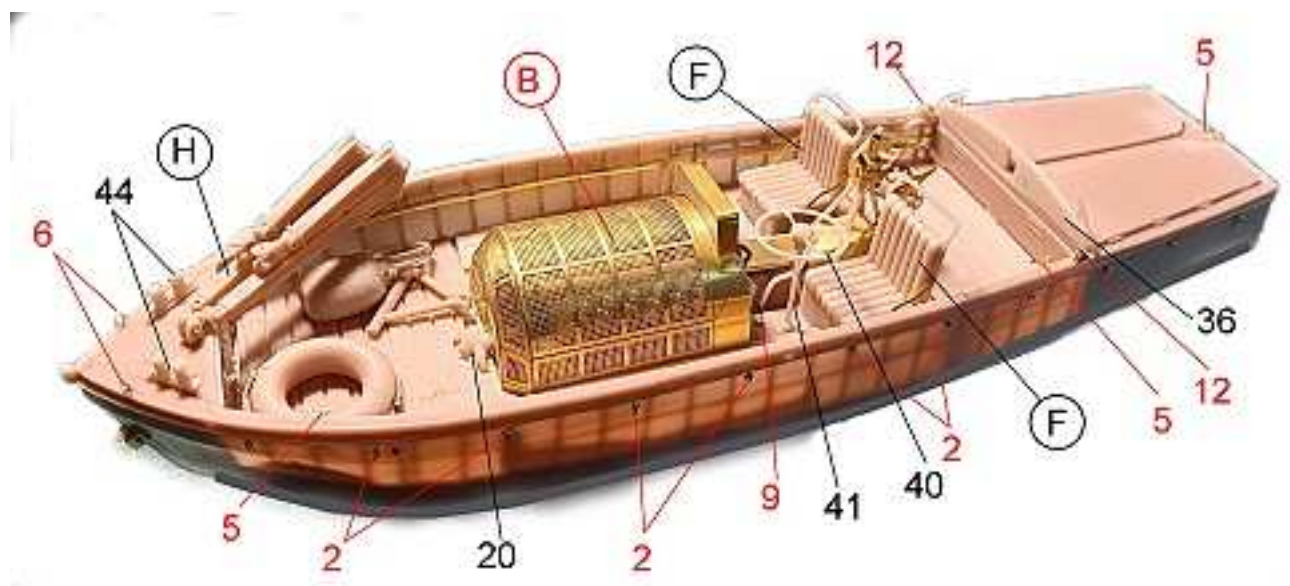

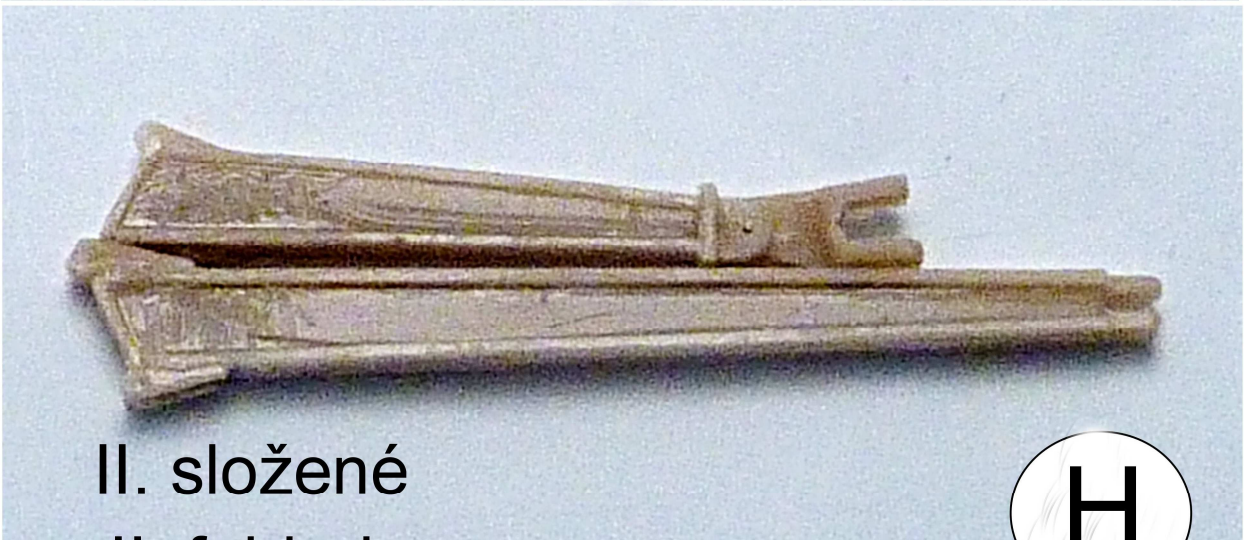
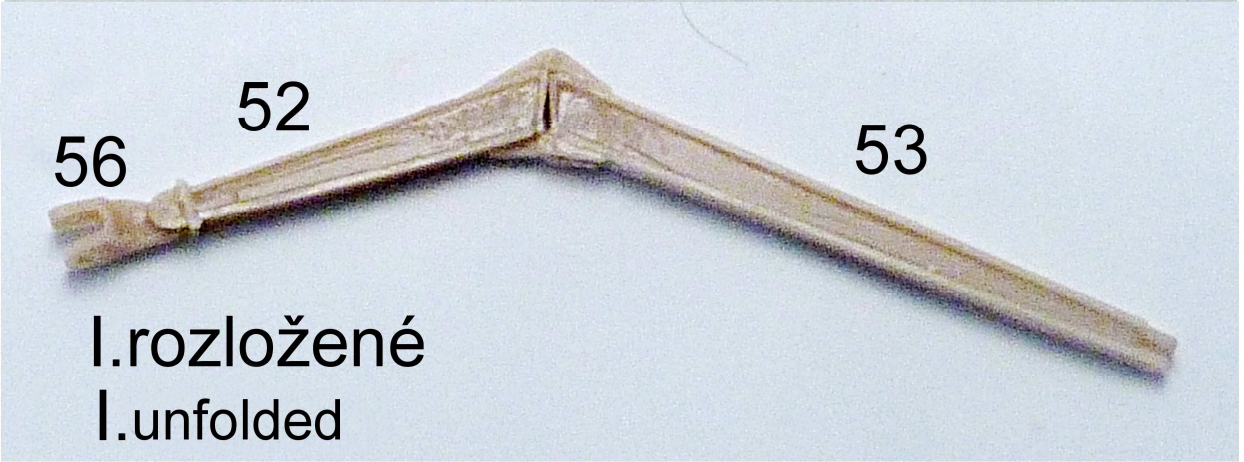
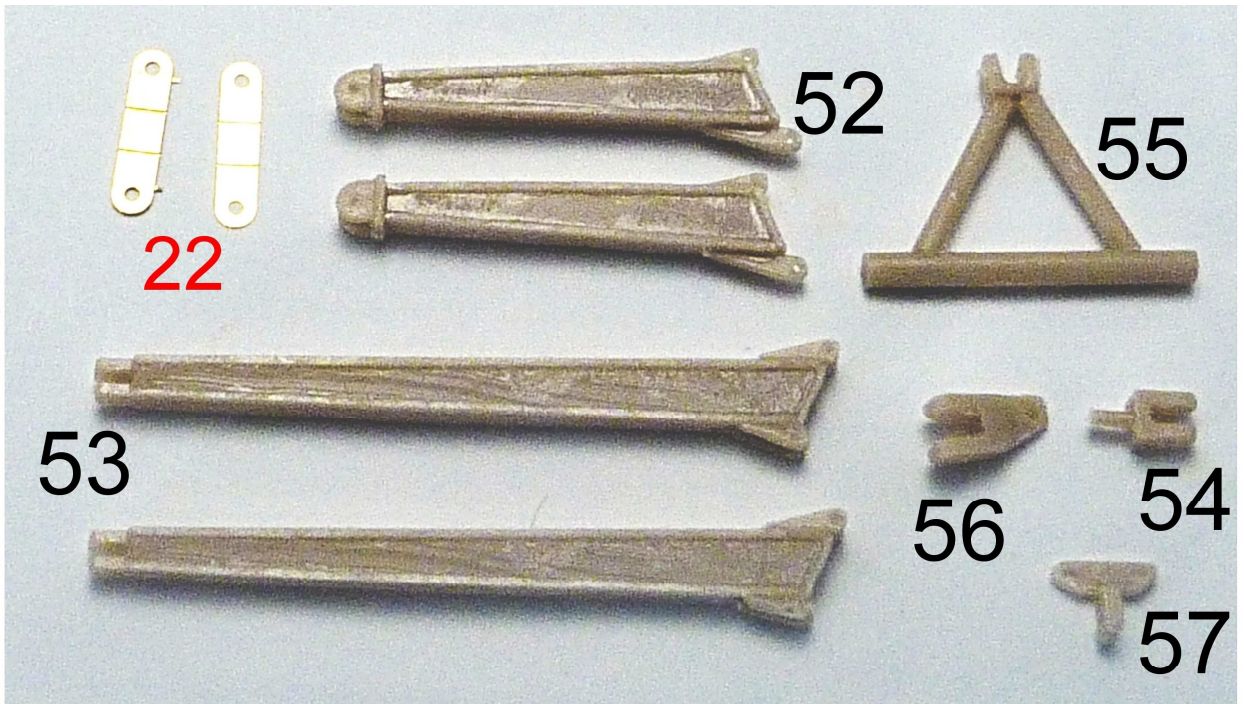

H

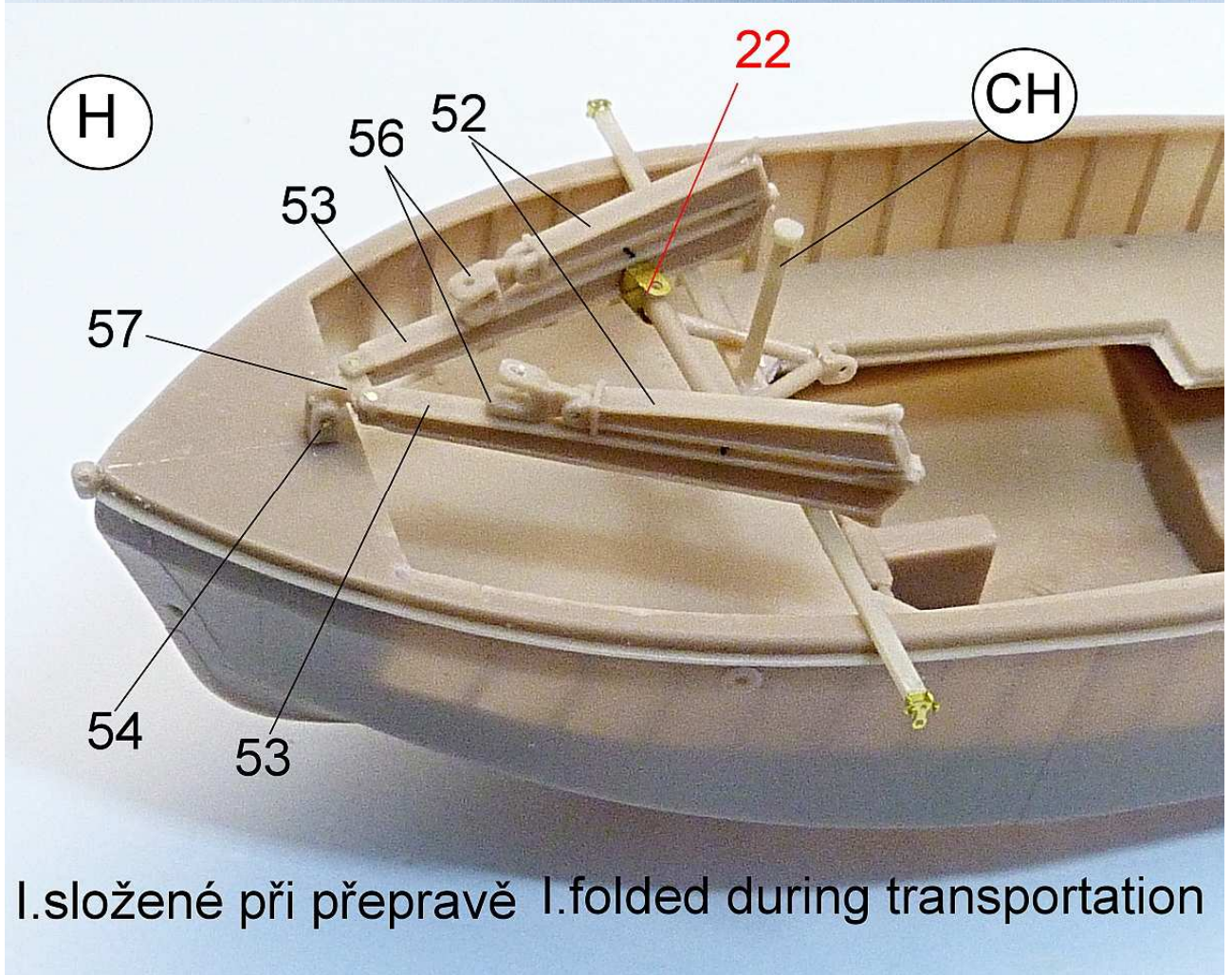
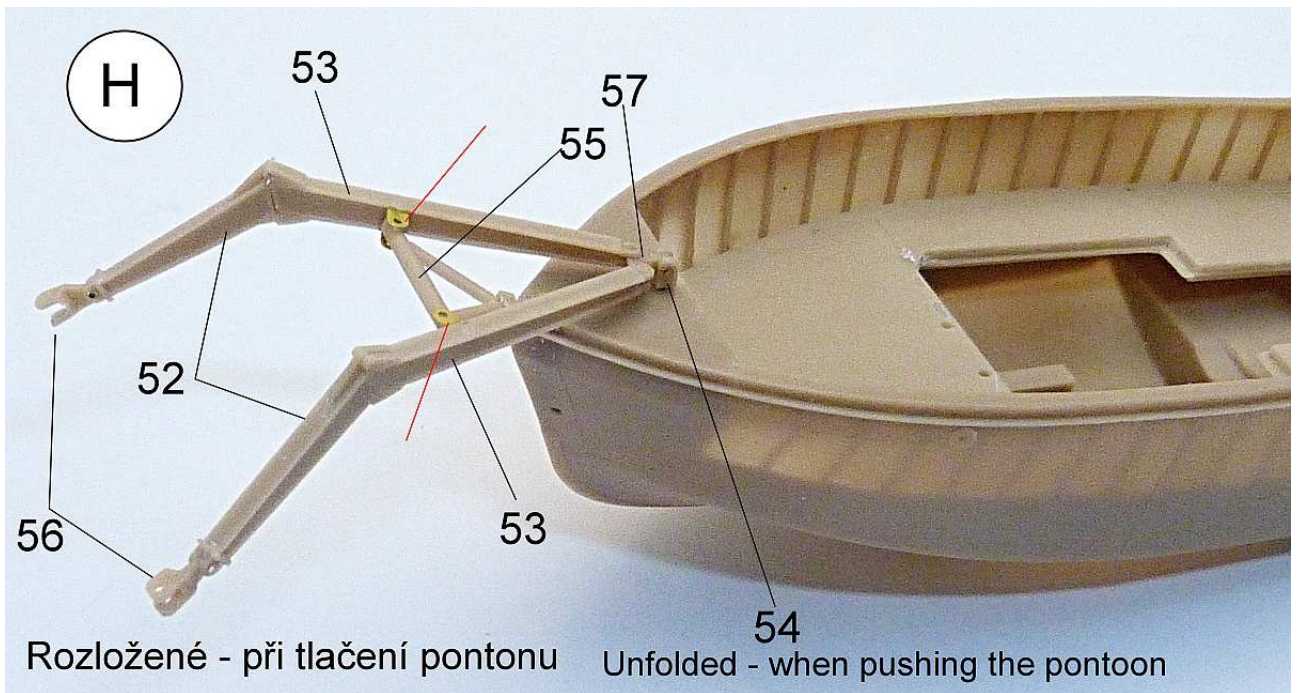

H

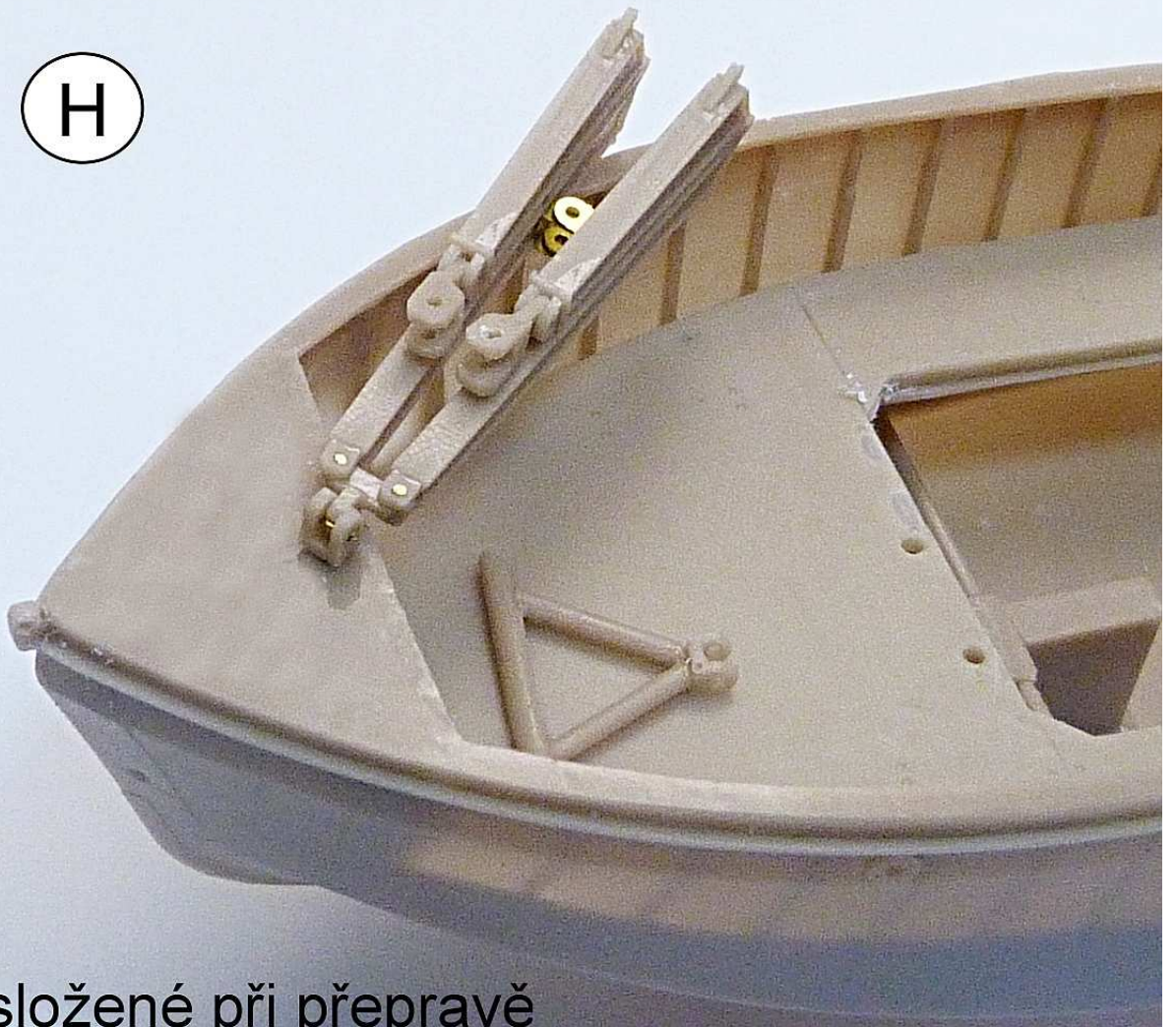

II.složené při přepravě

II.folded during transportation

CH

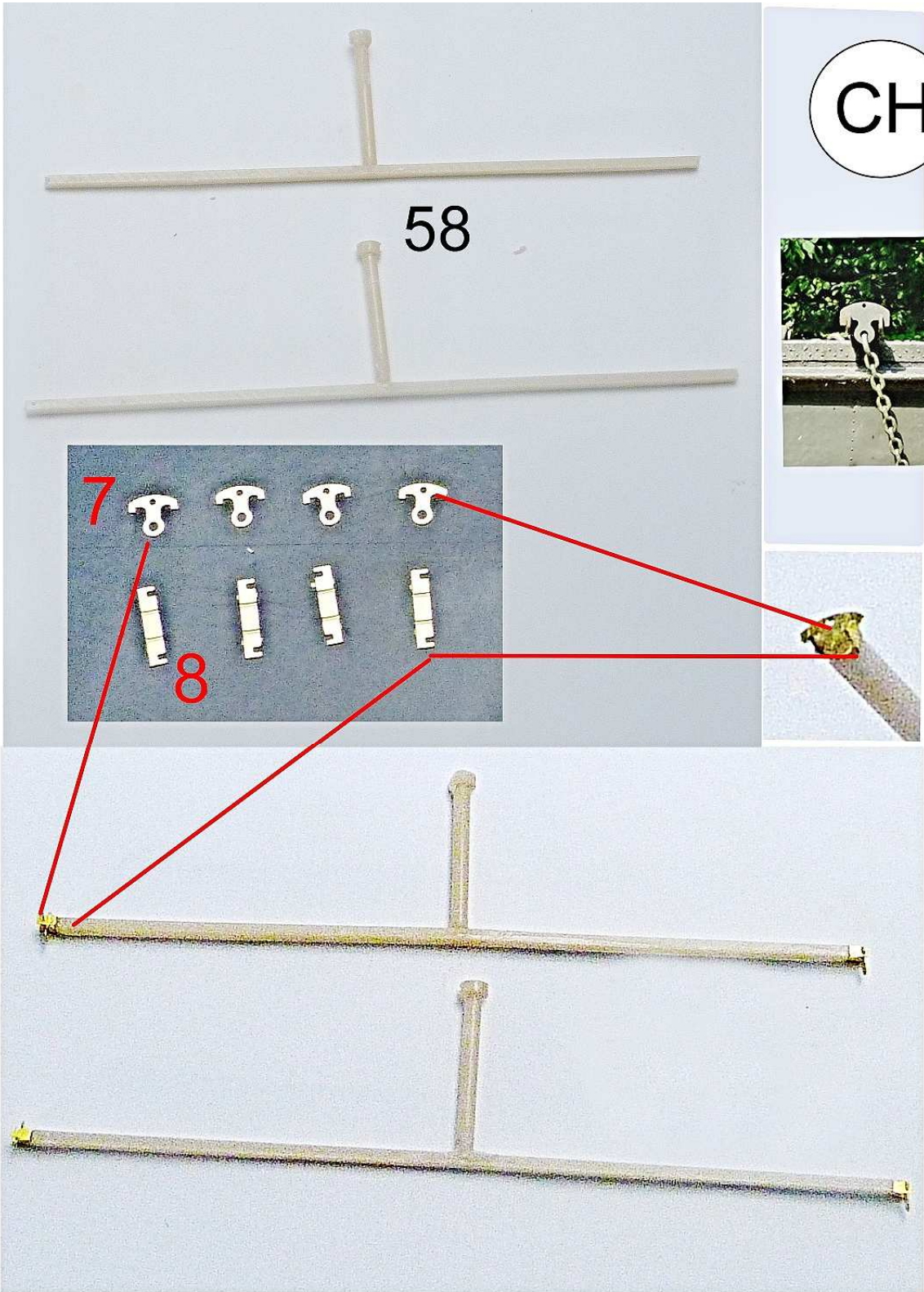

Pouze pro upevnění k přívěsu M5  
For attachment to M5 trailer only







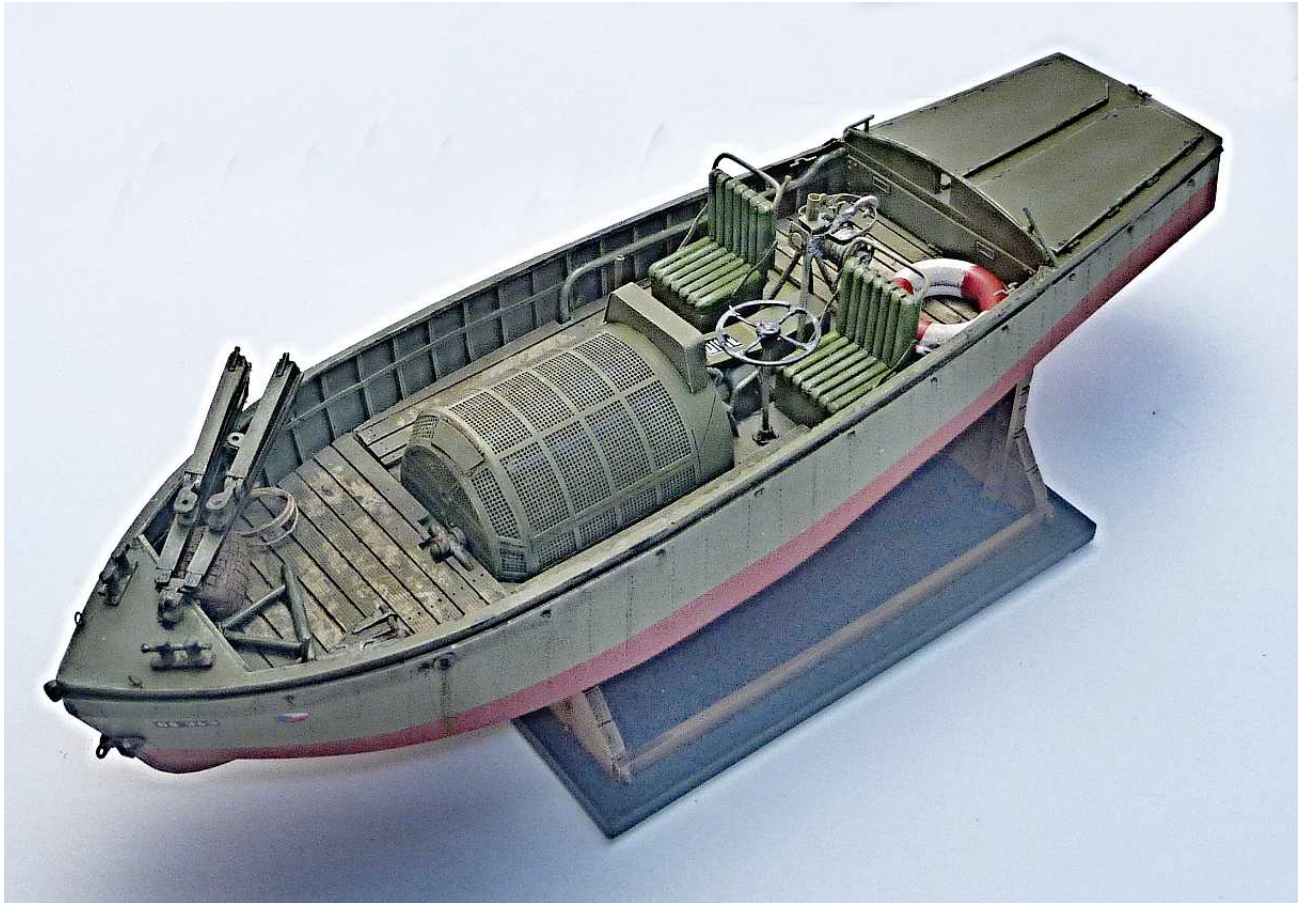





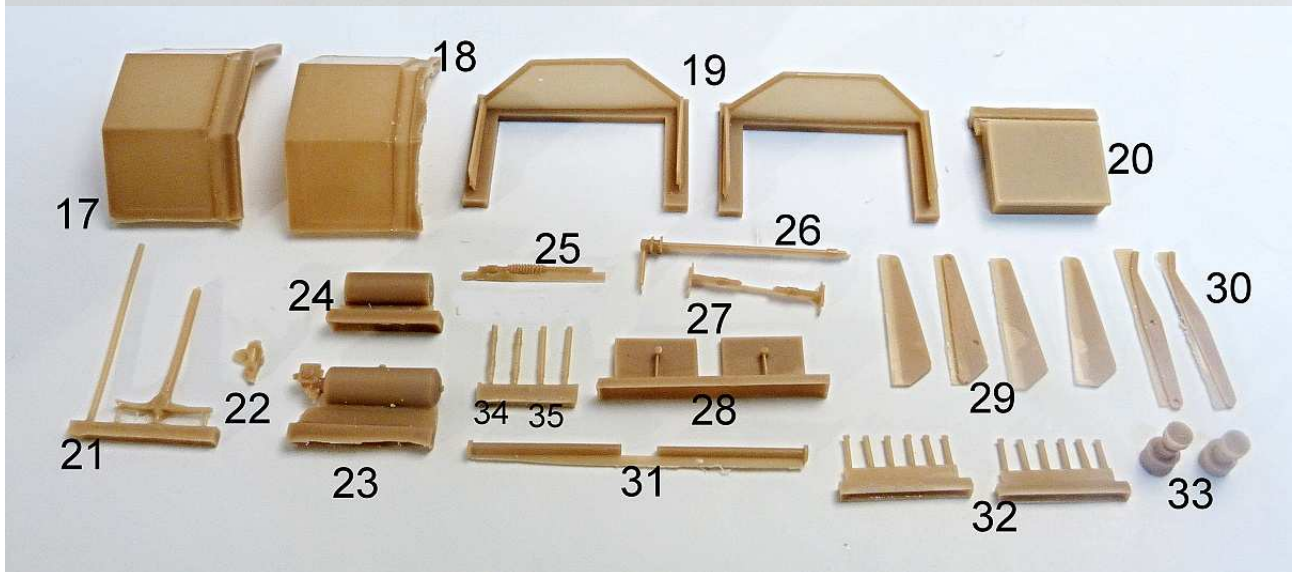
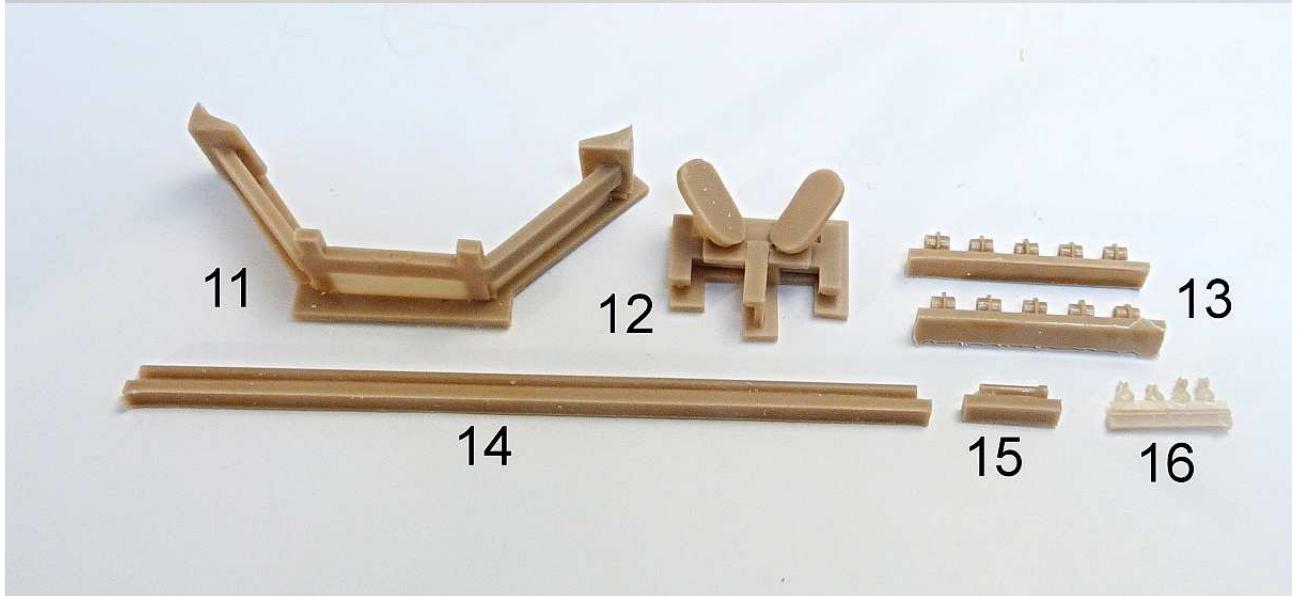
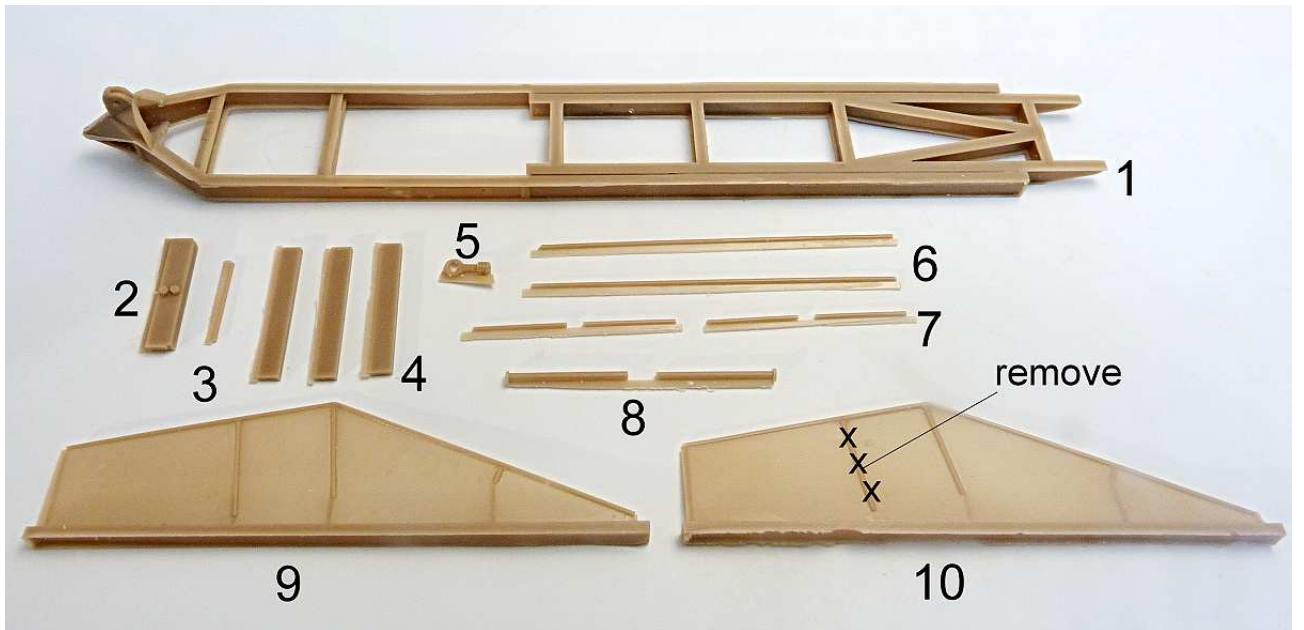

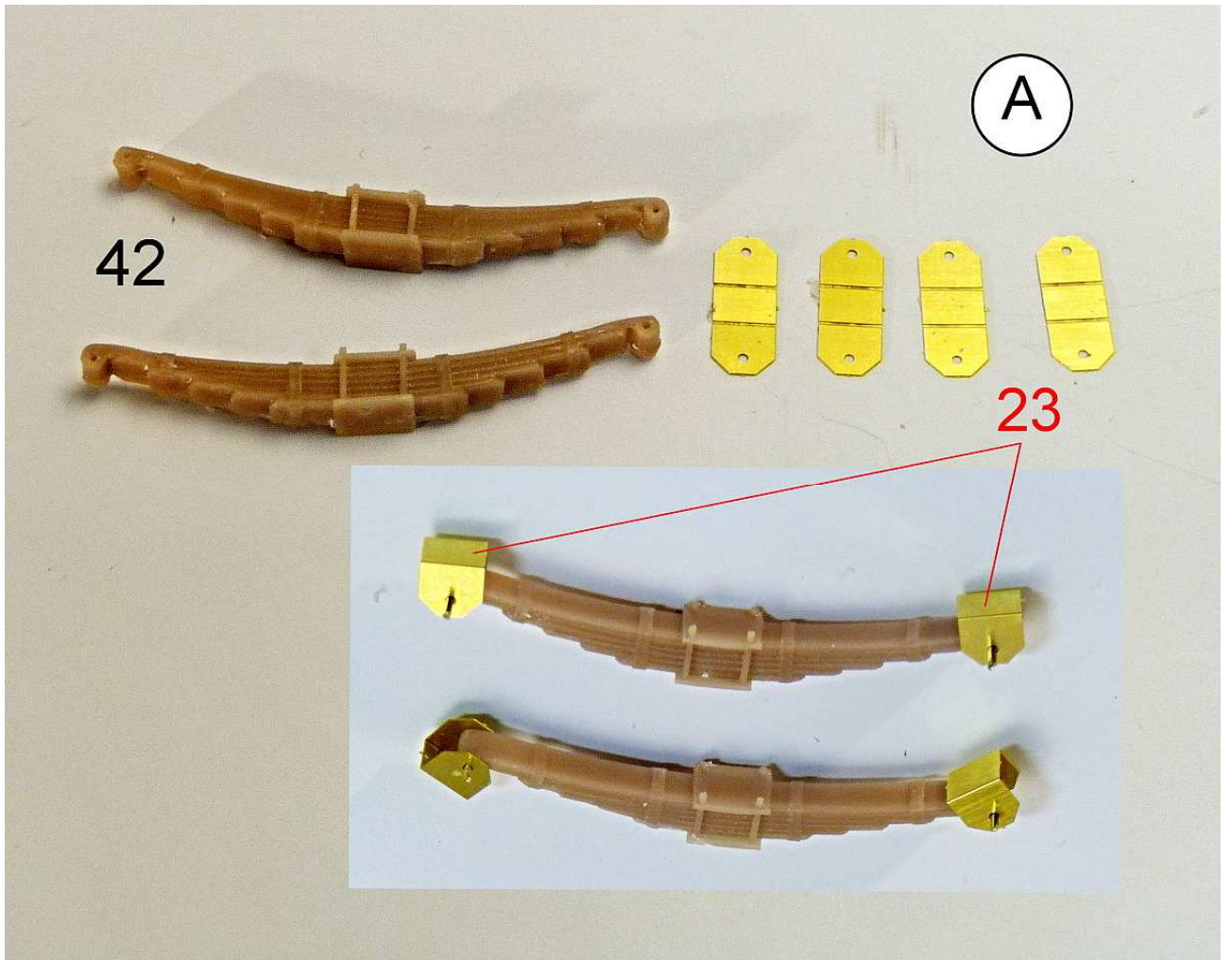
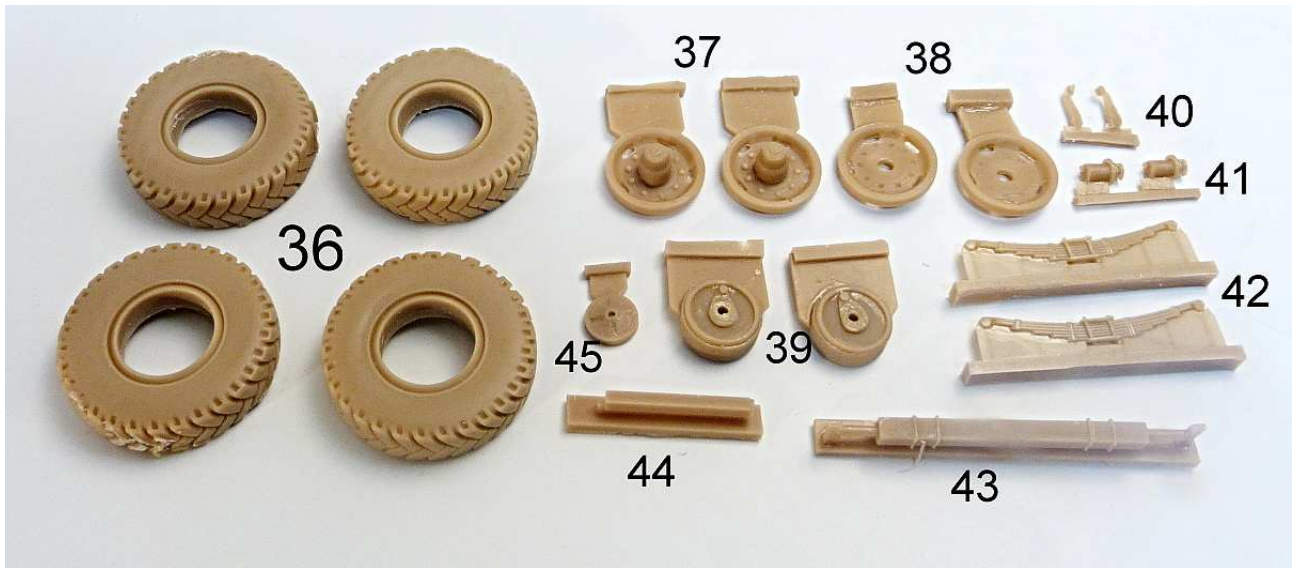

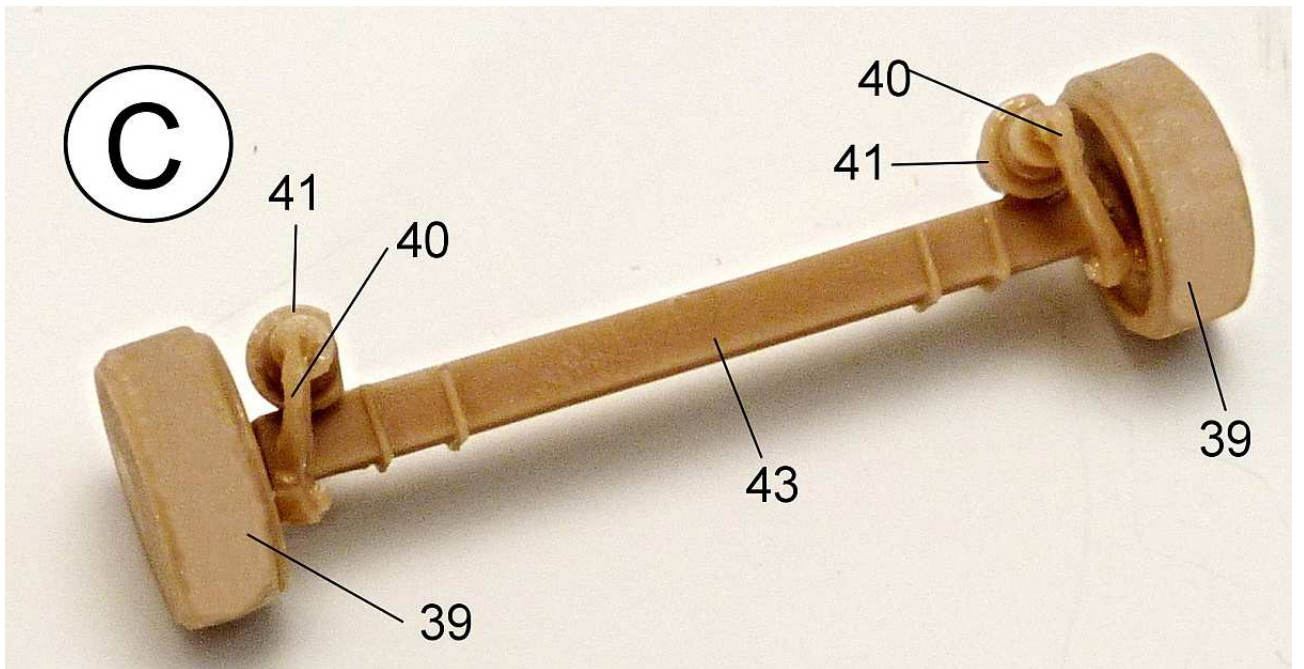
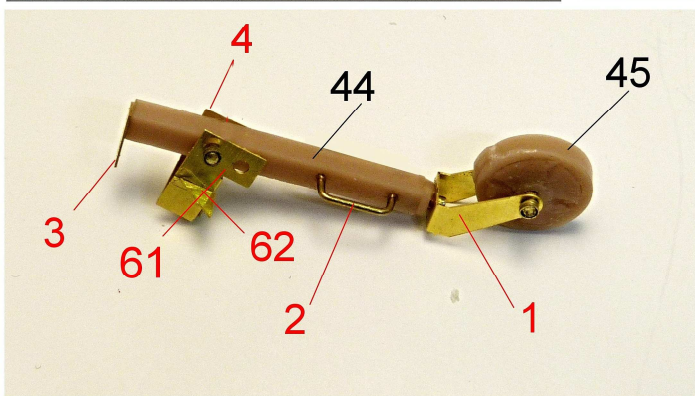
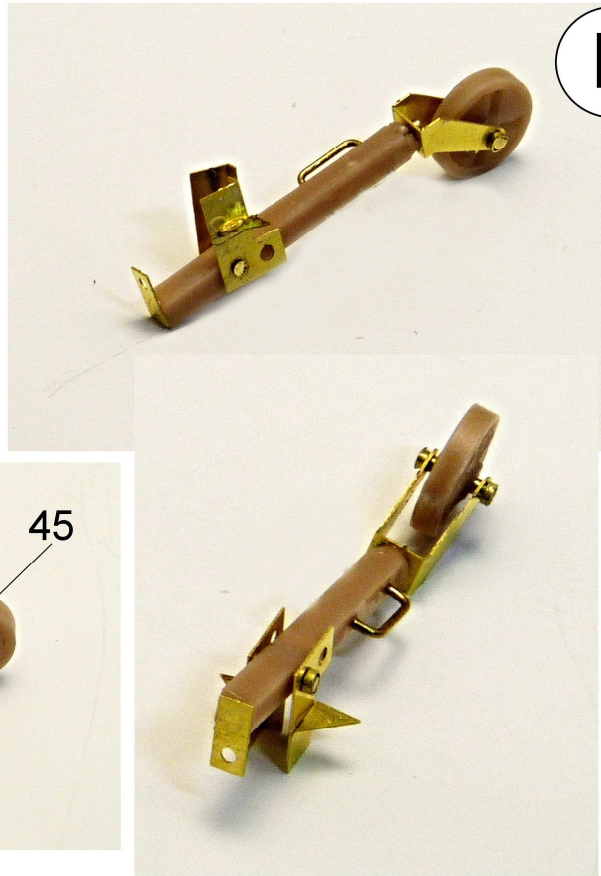
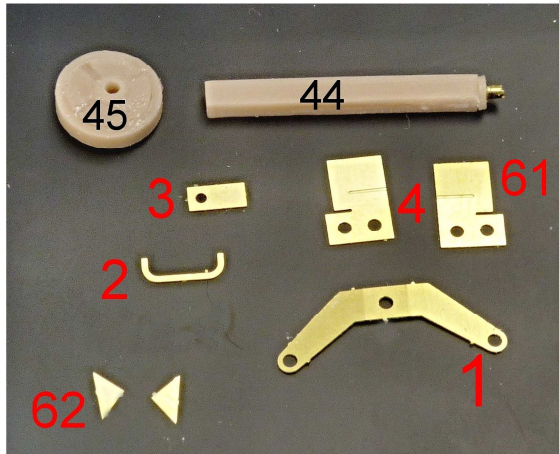



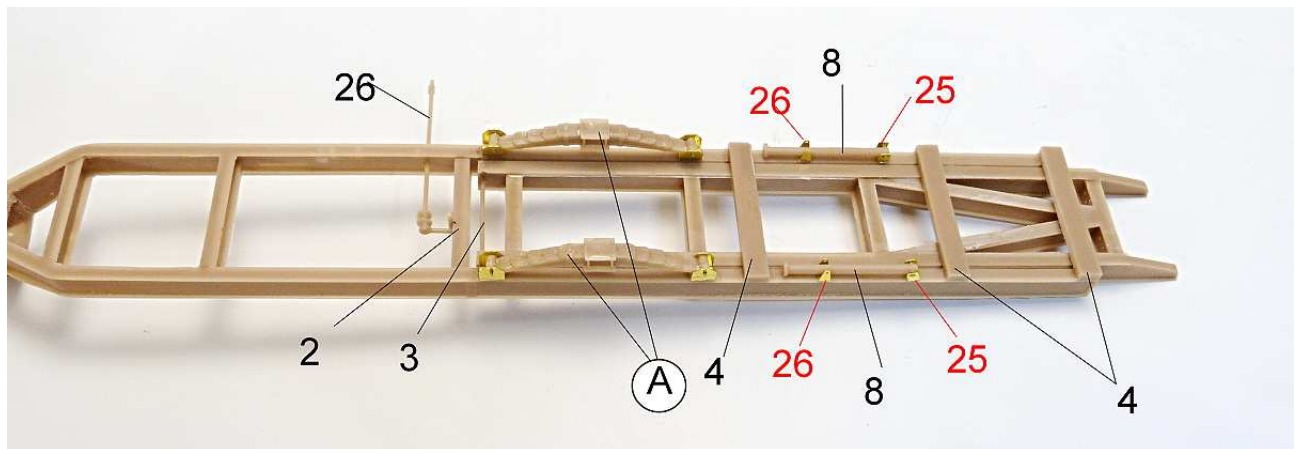
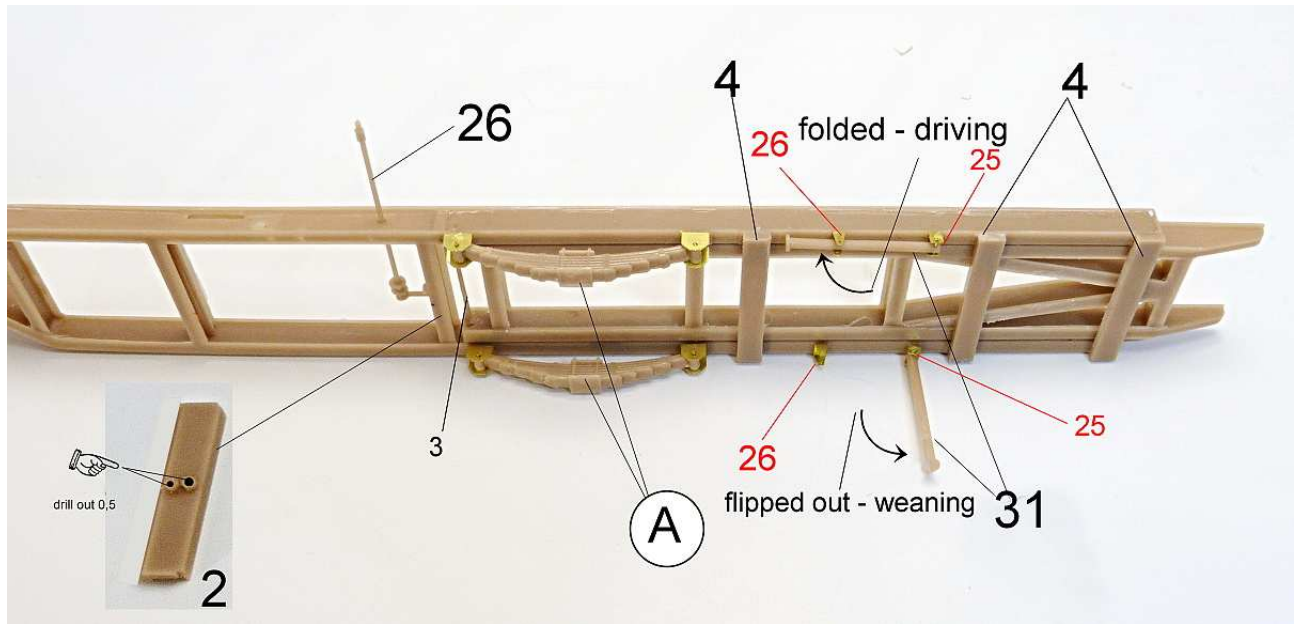

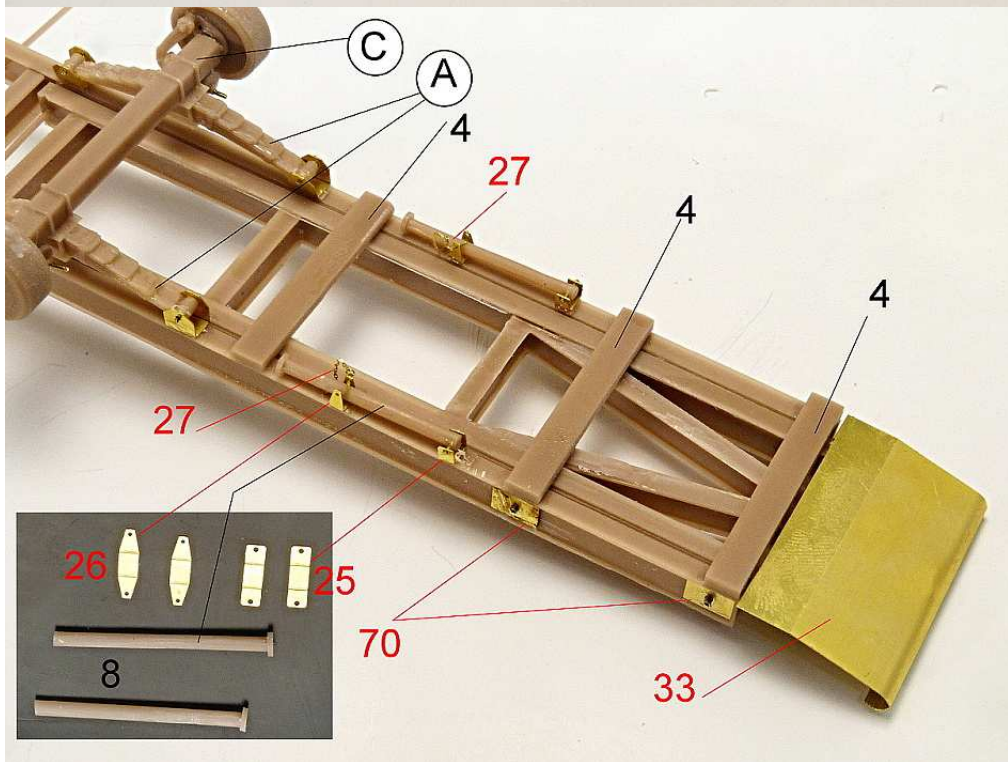
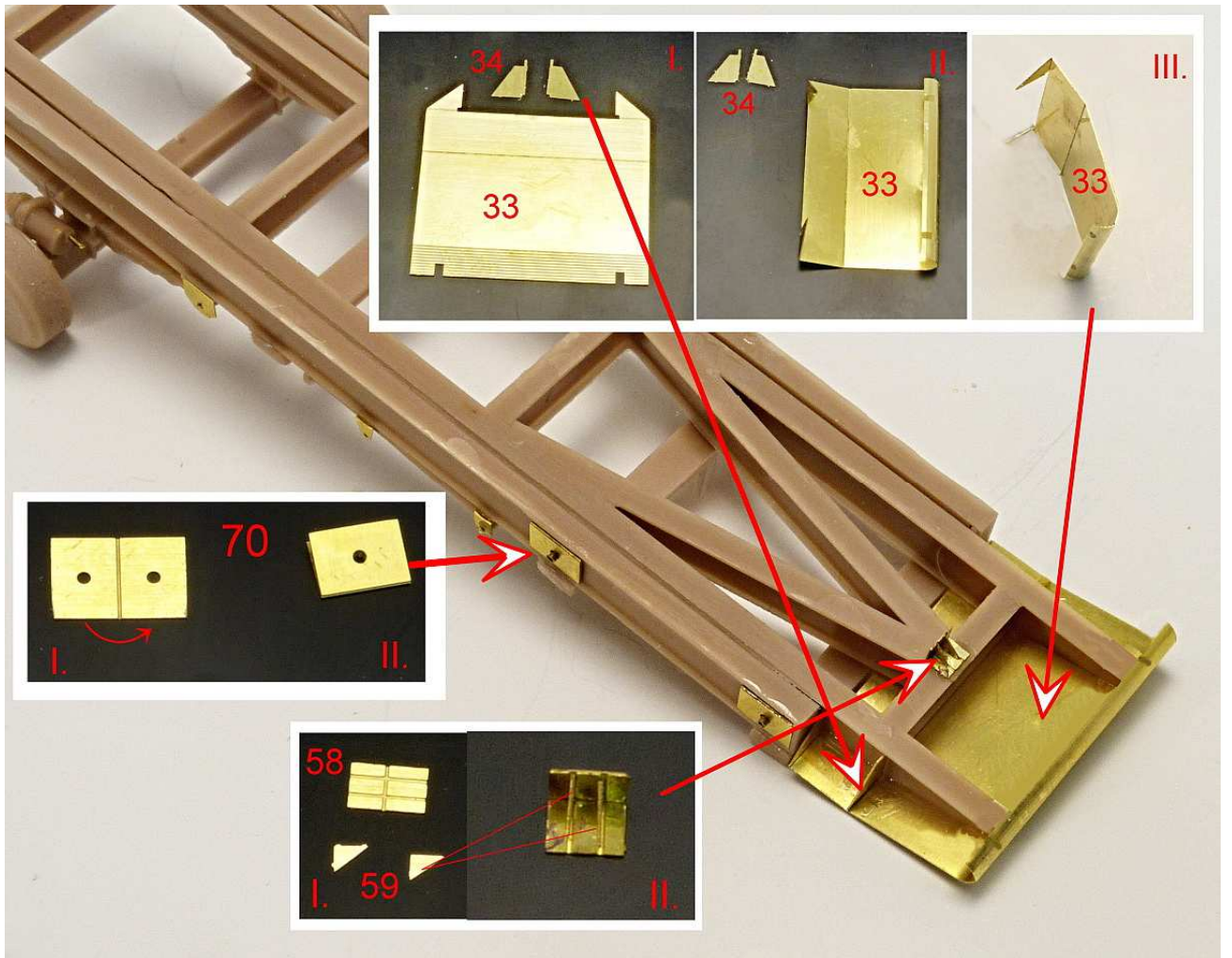

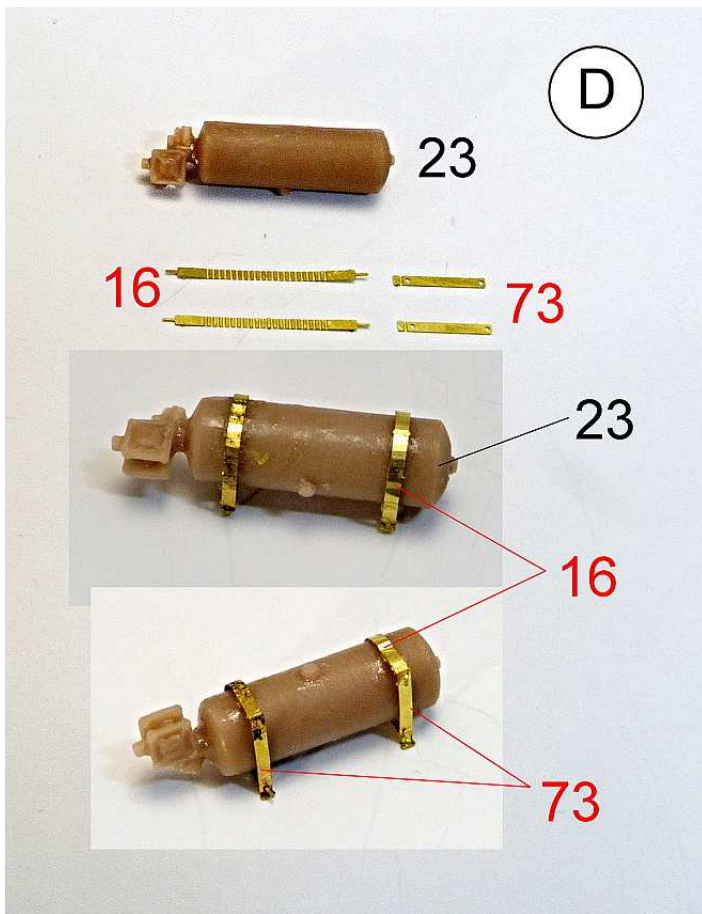
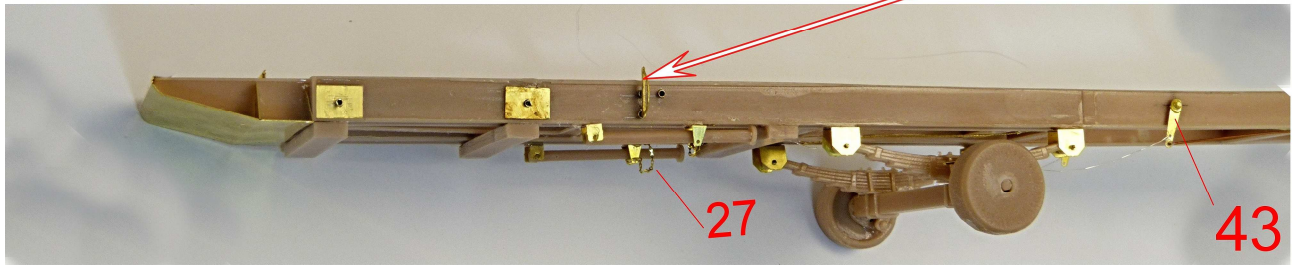
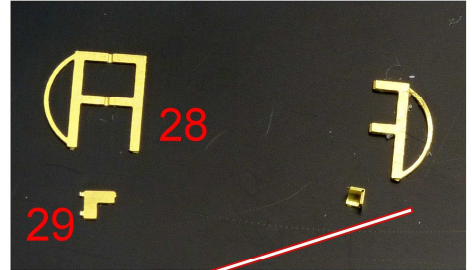
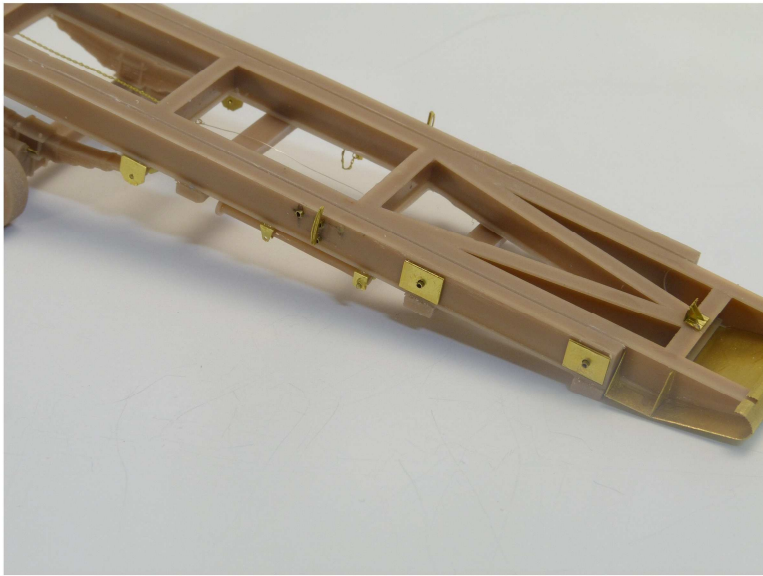



44

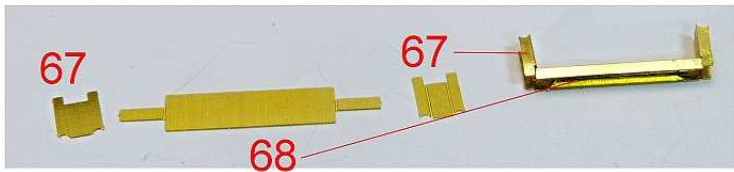
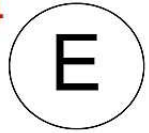

25

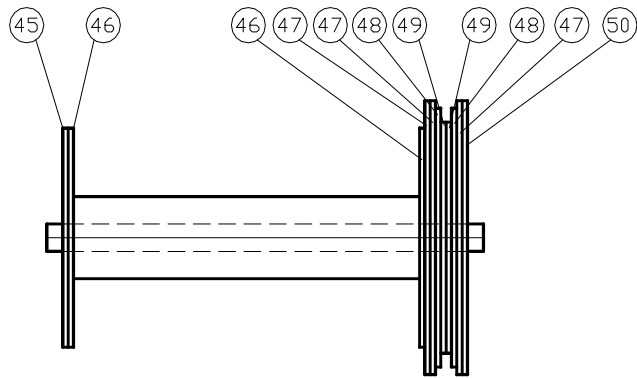

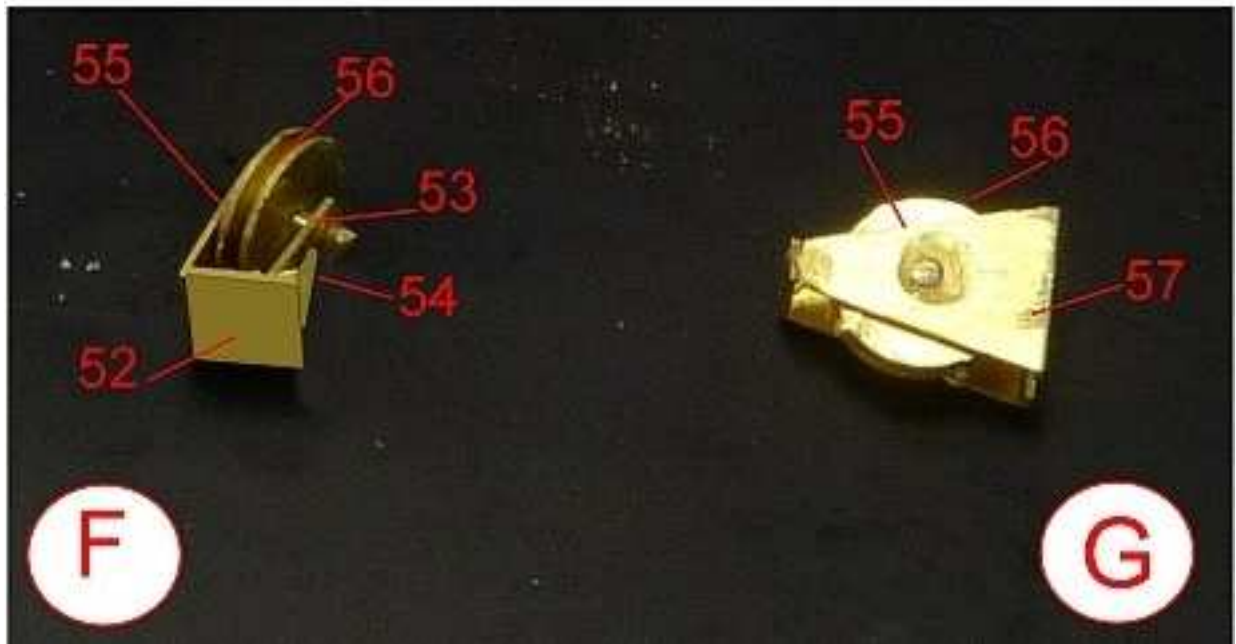
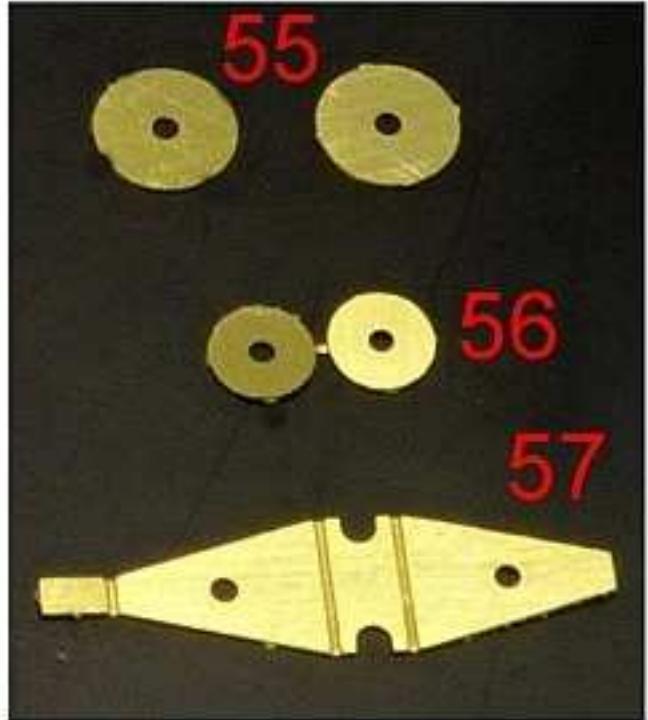

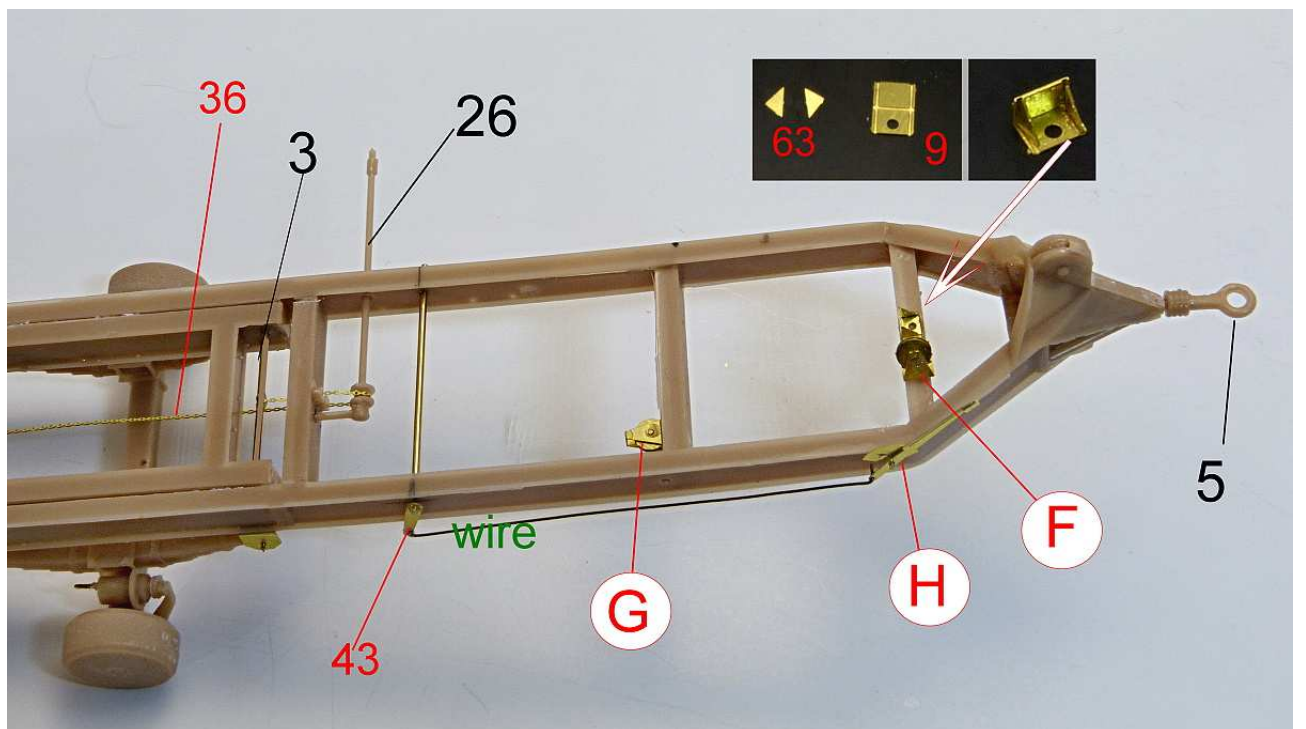

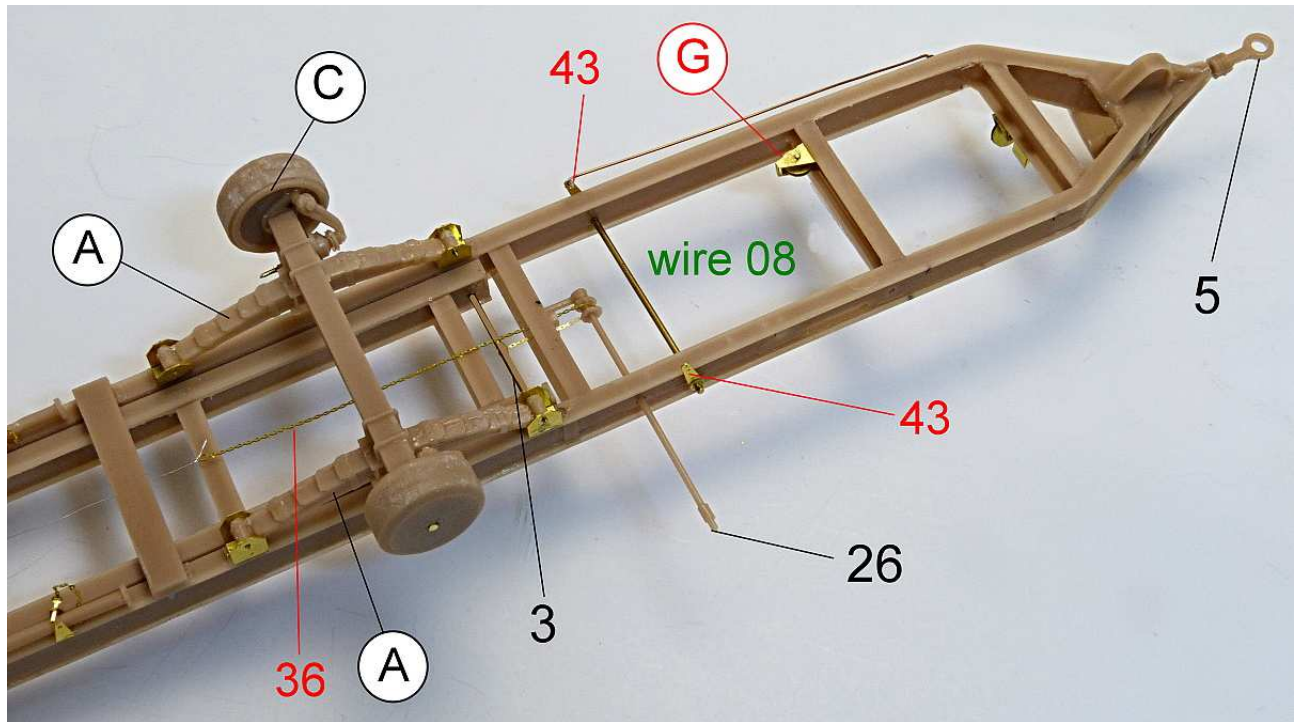

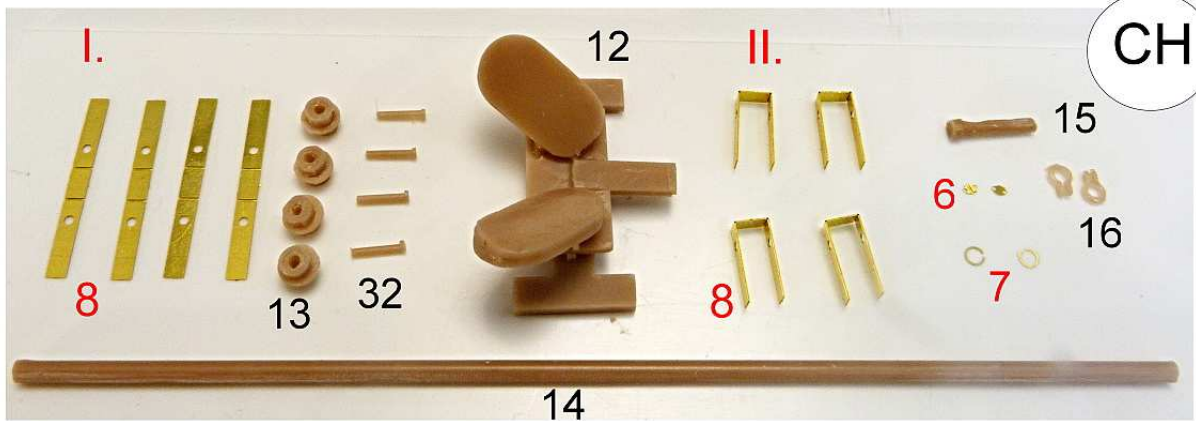

CH

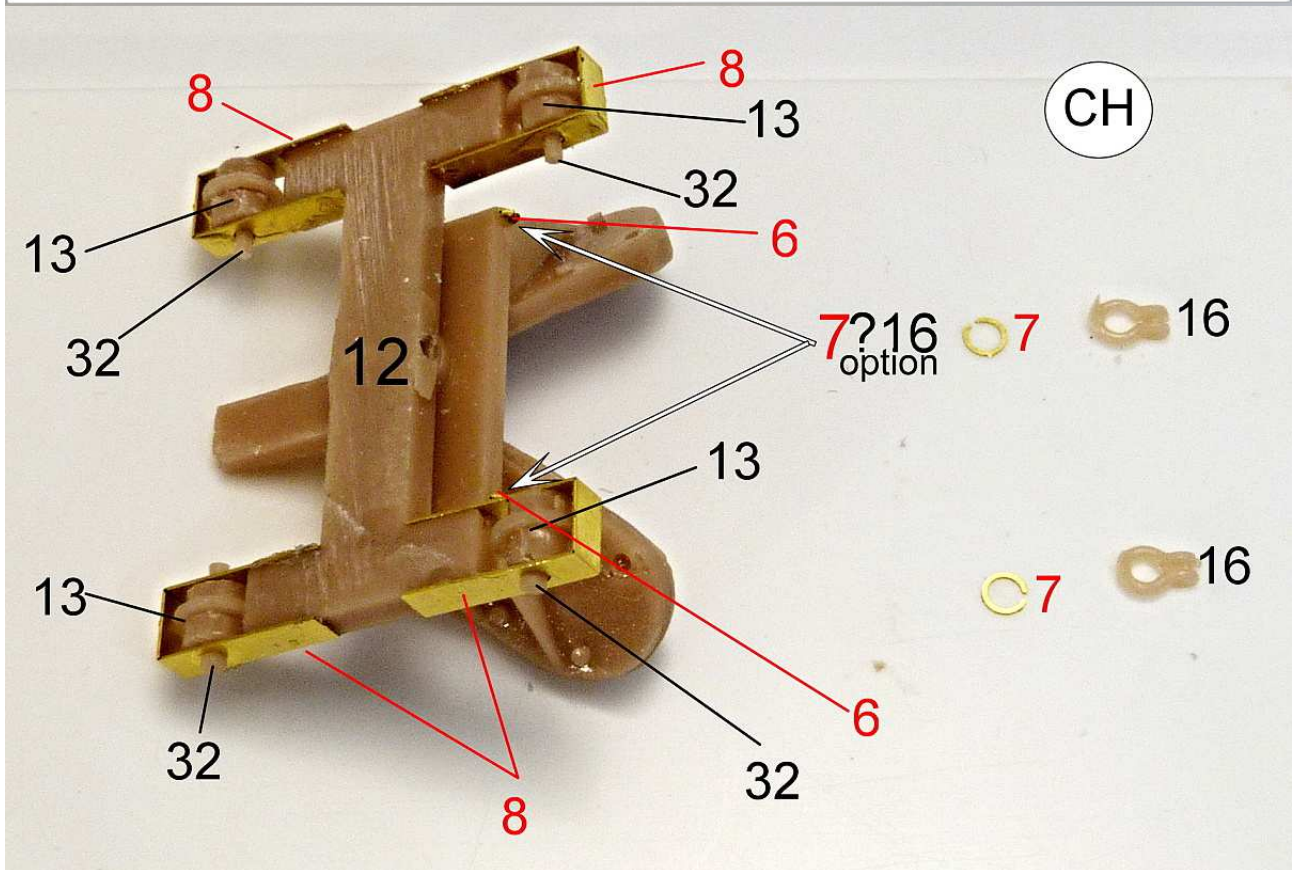

CH



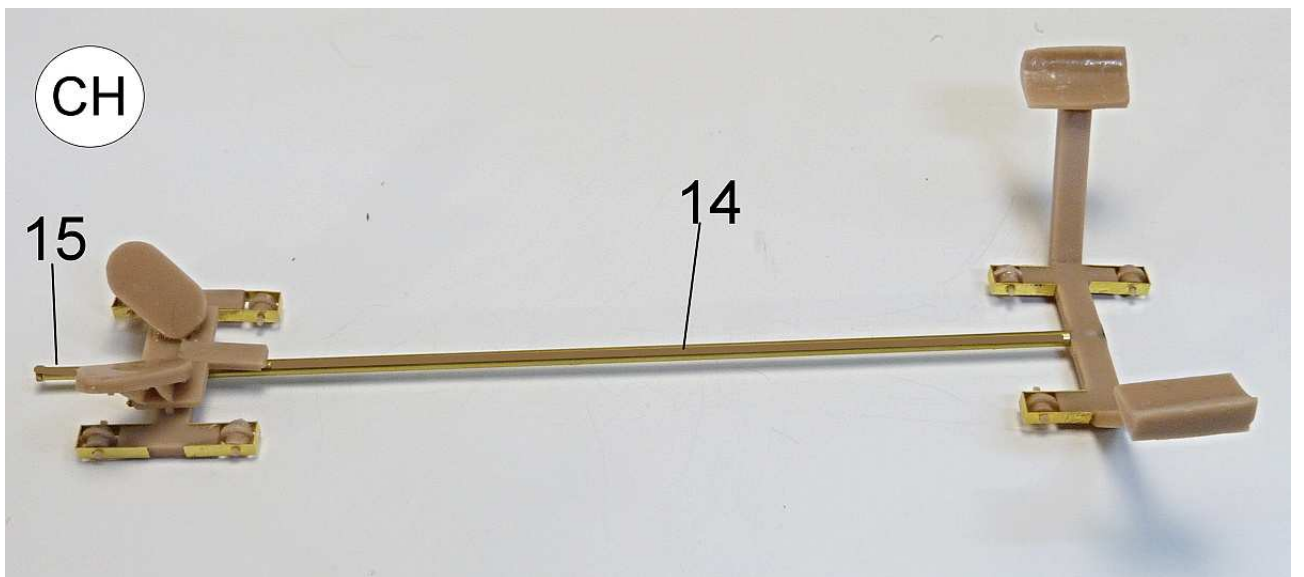
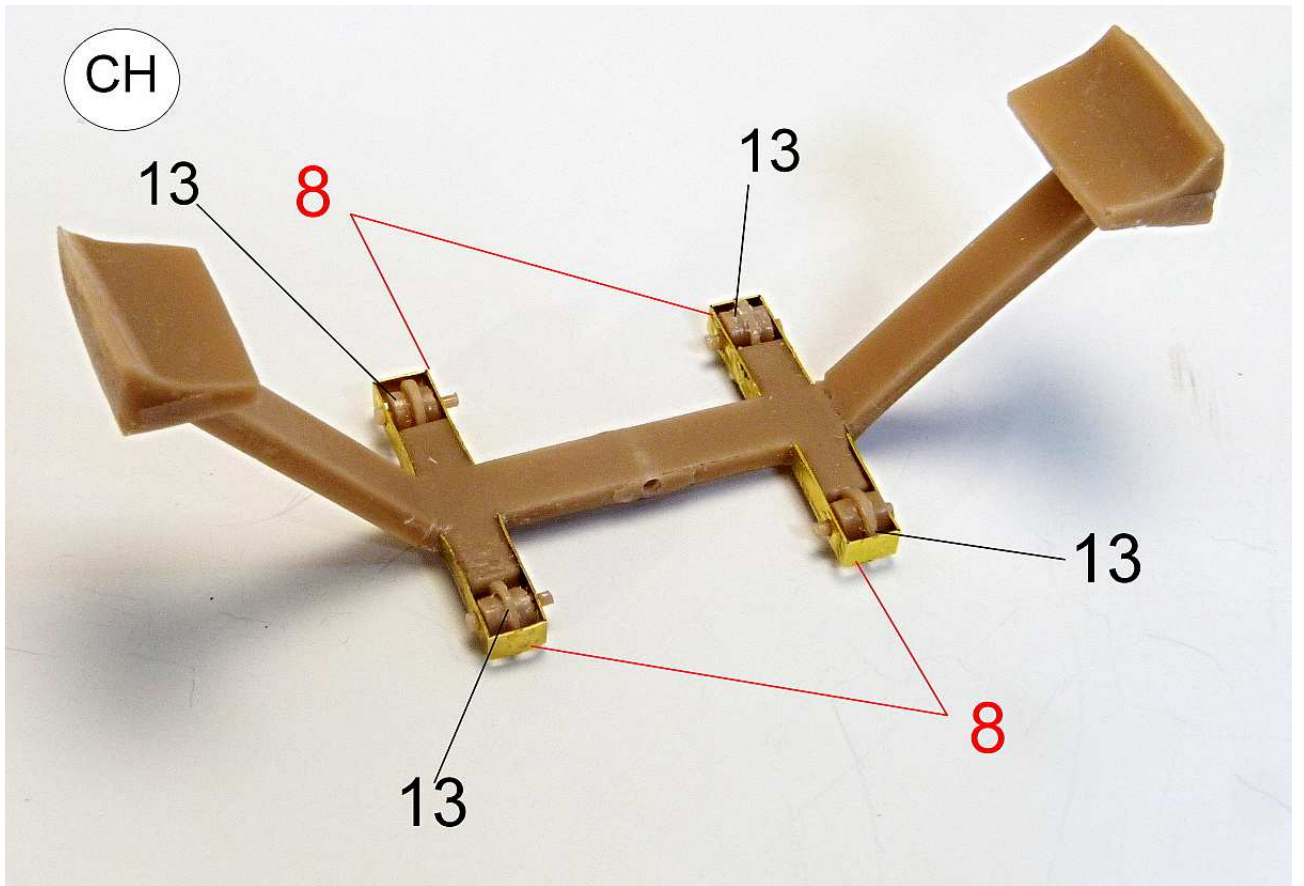

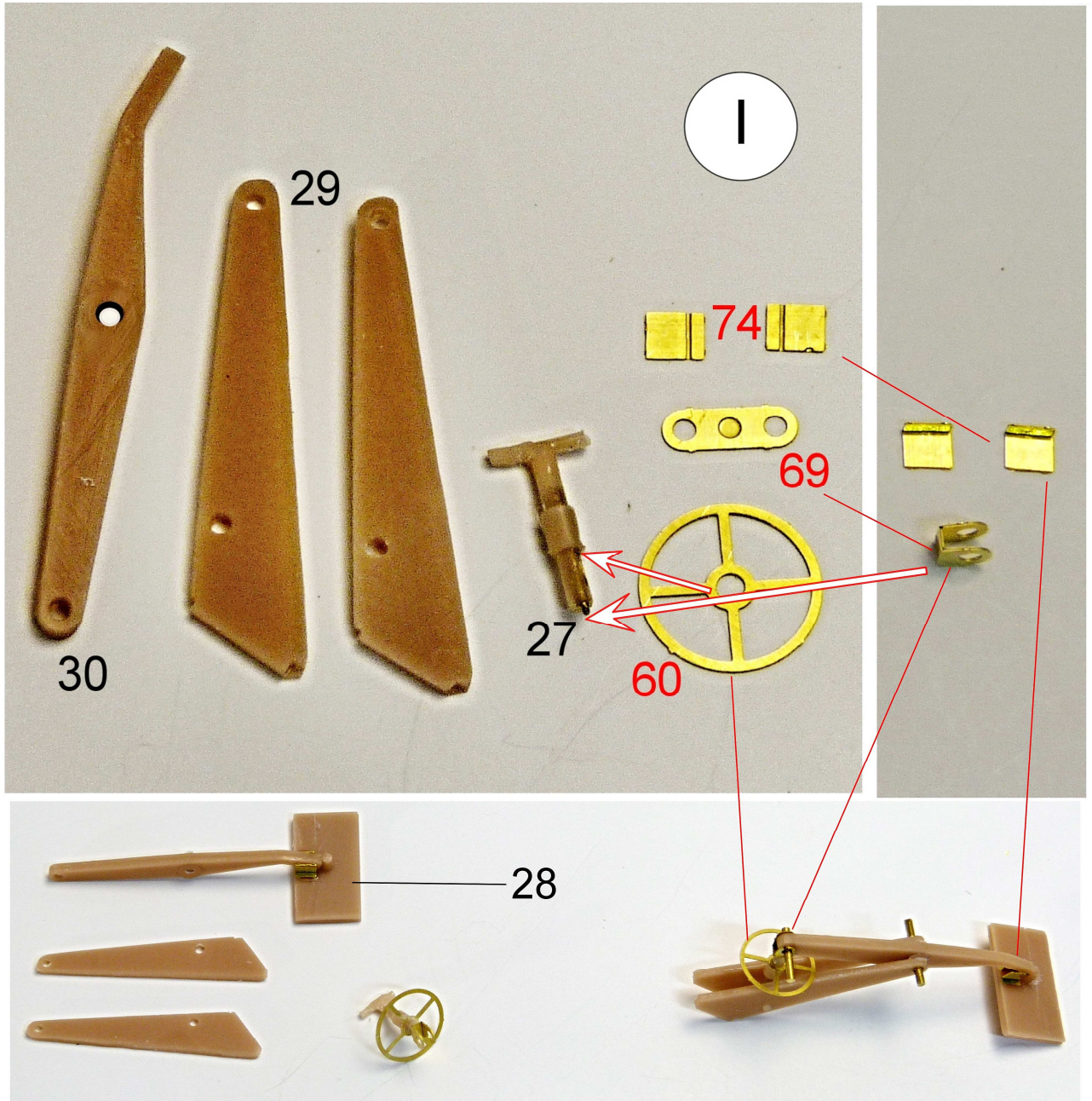

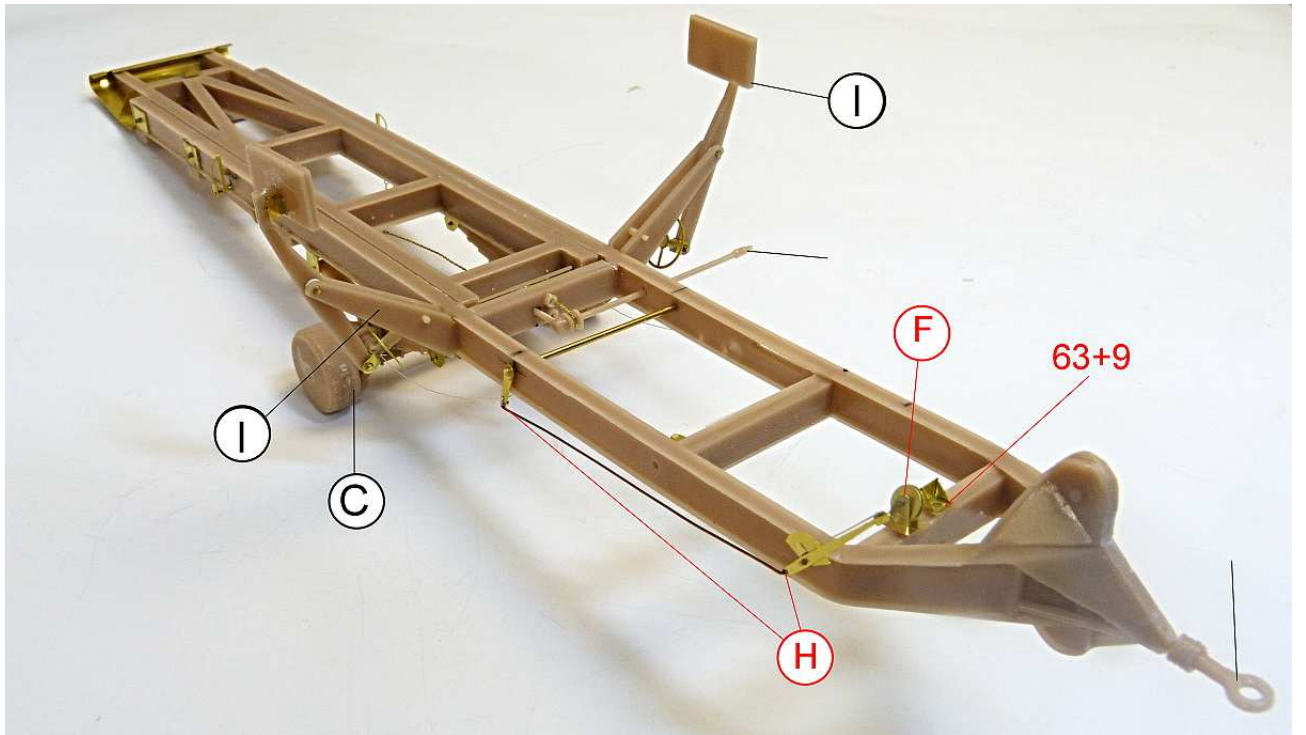
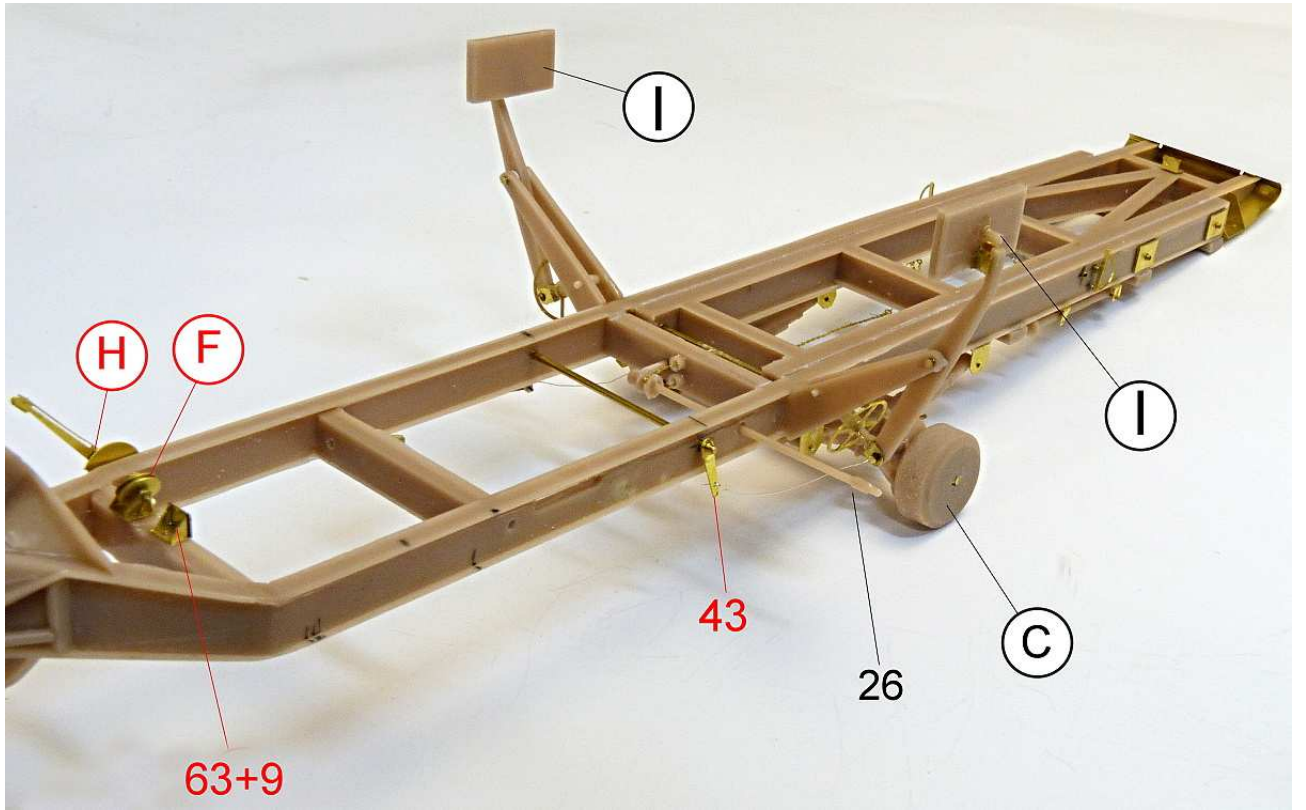

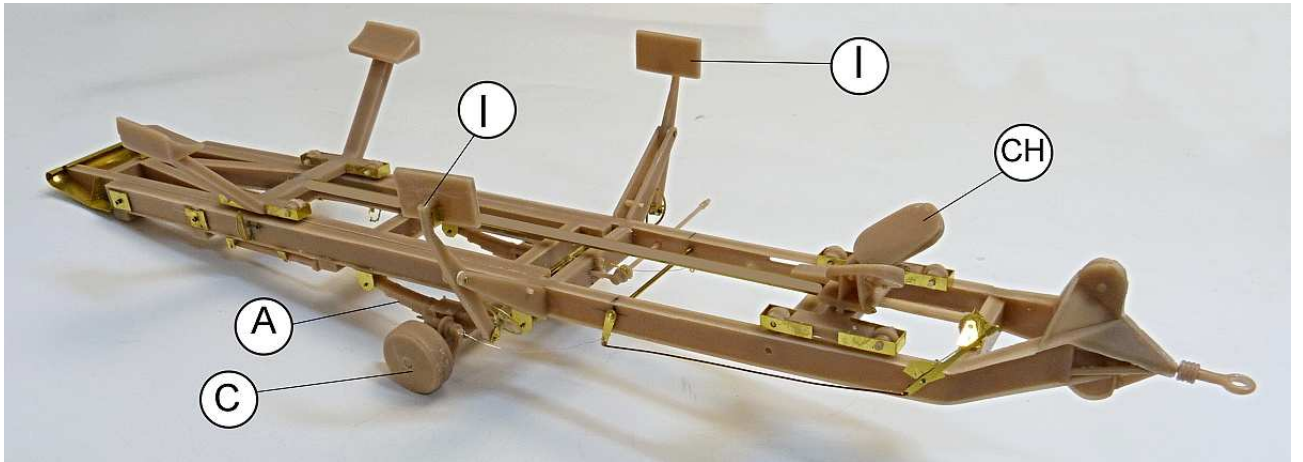

**J**

Winch crank

Option: 34 for saving

35 for use



**K** left



right

**L**

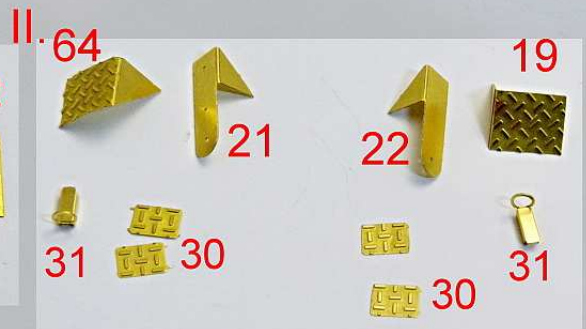
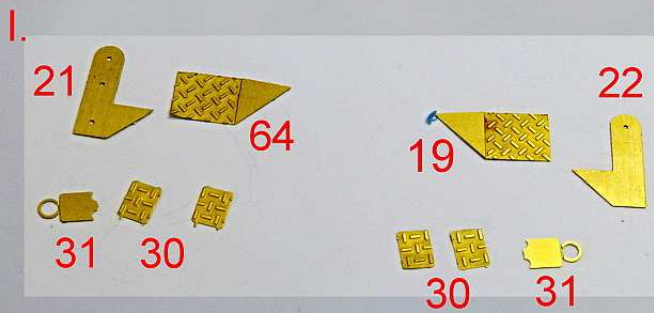
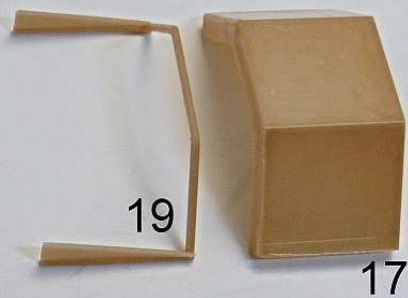

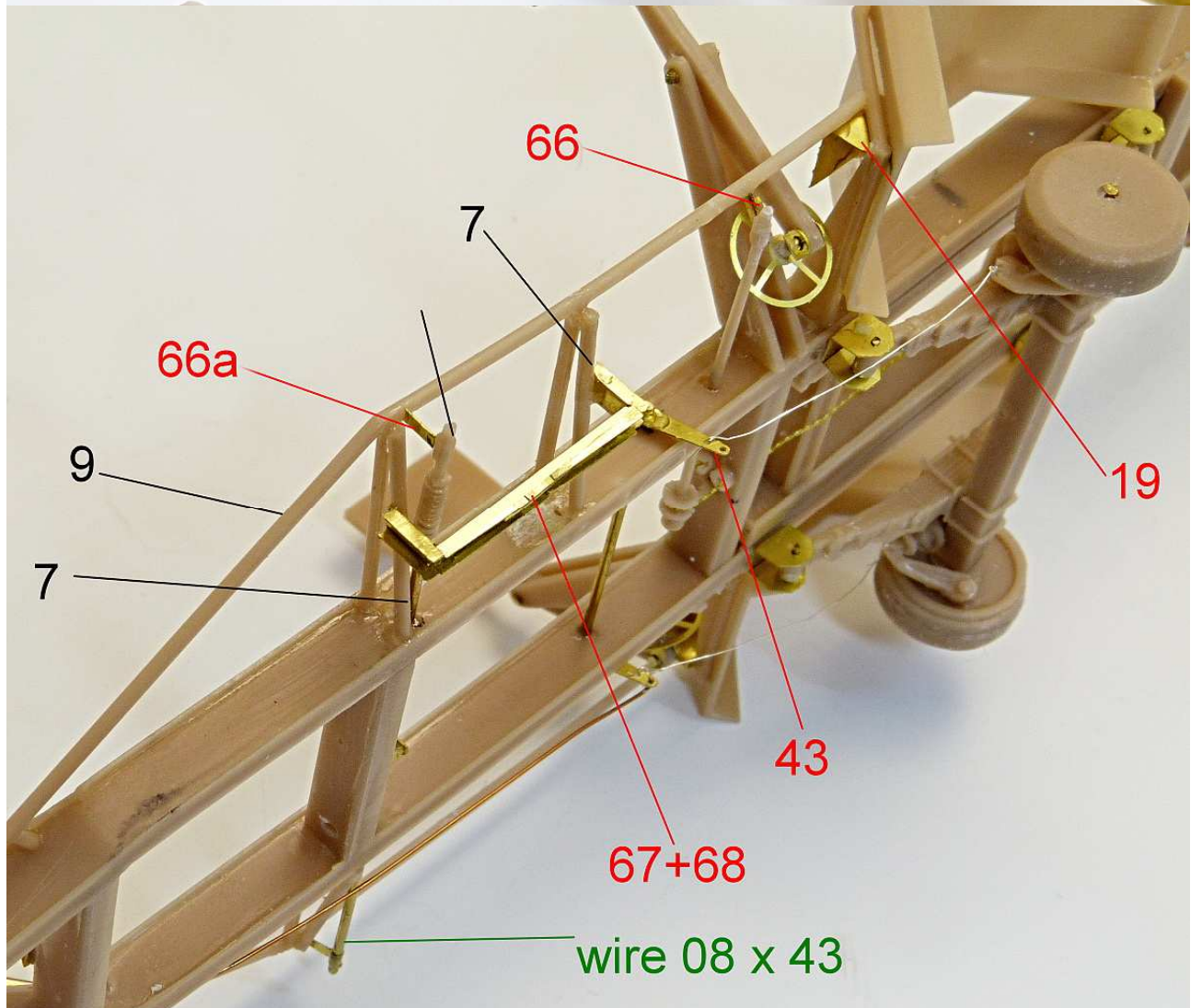
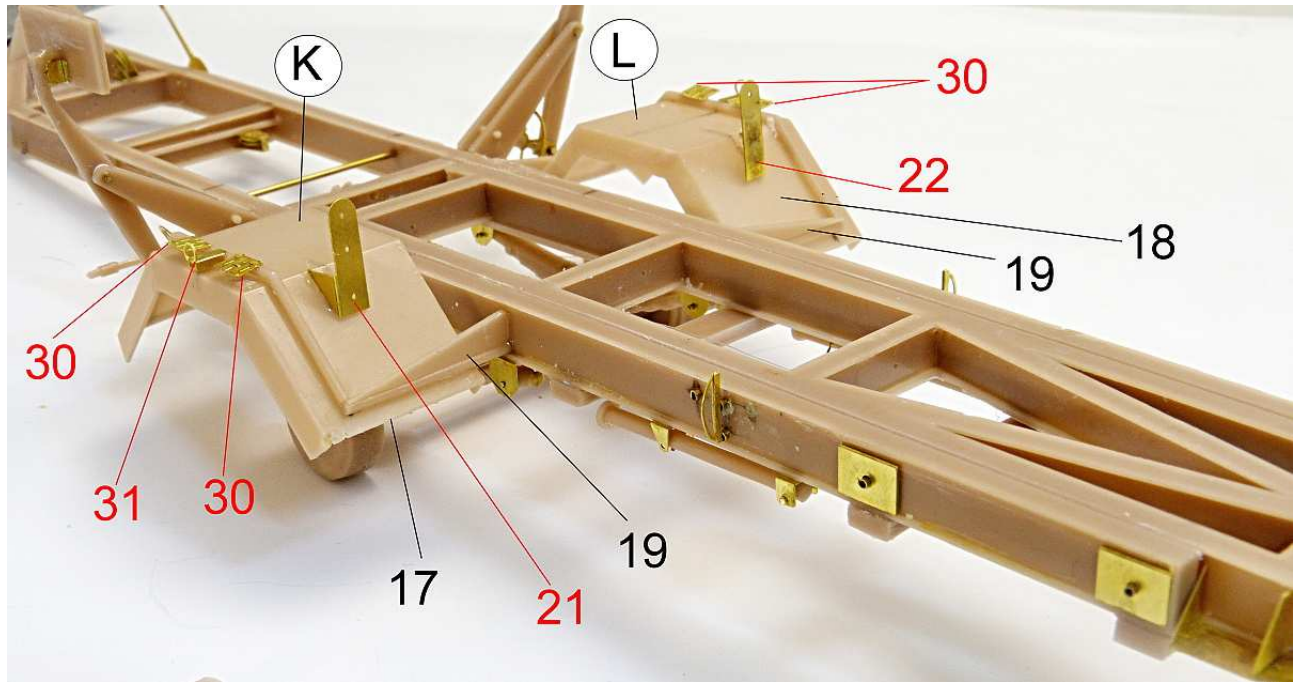

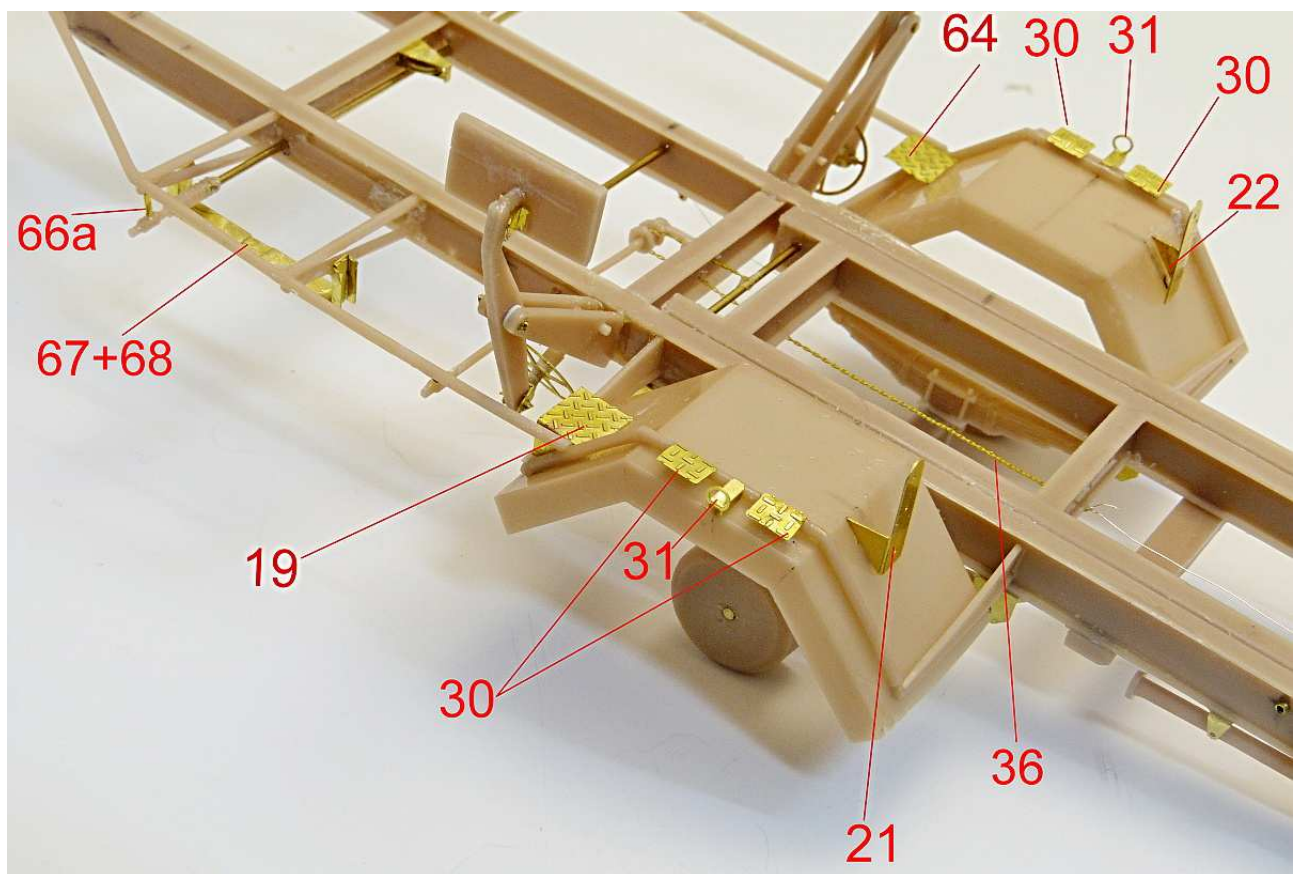
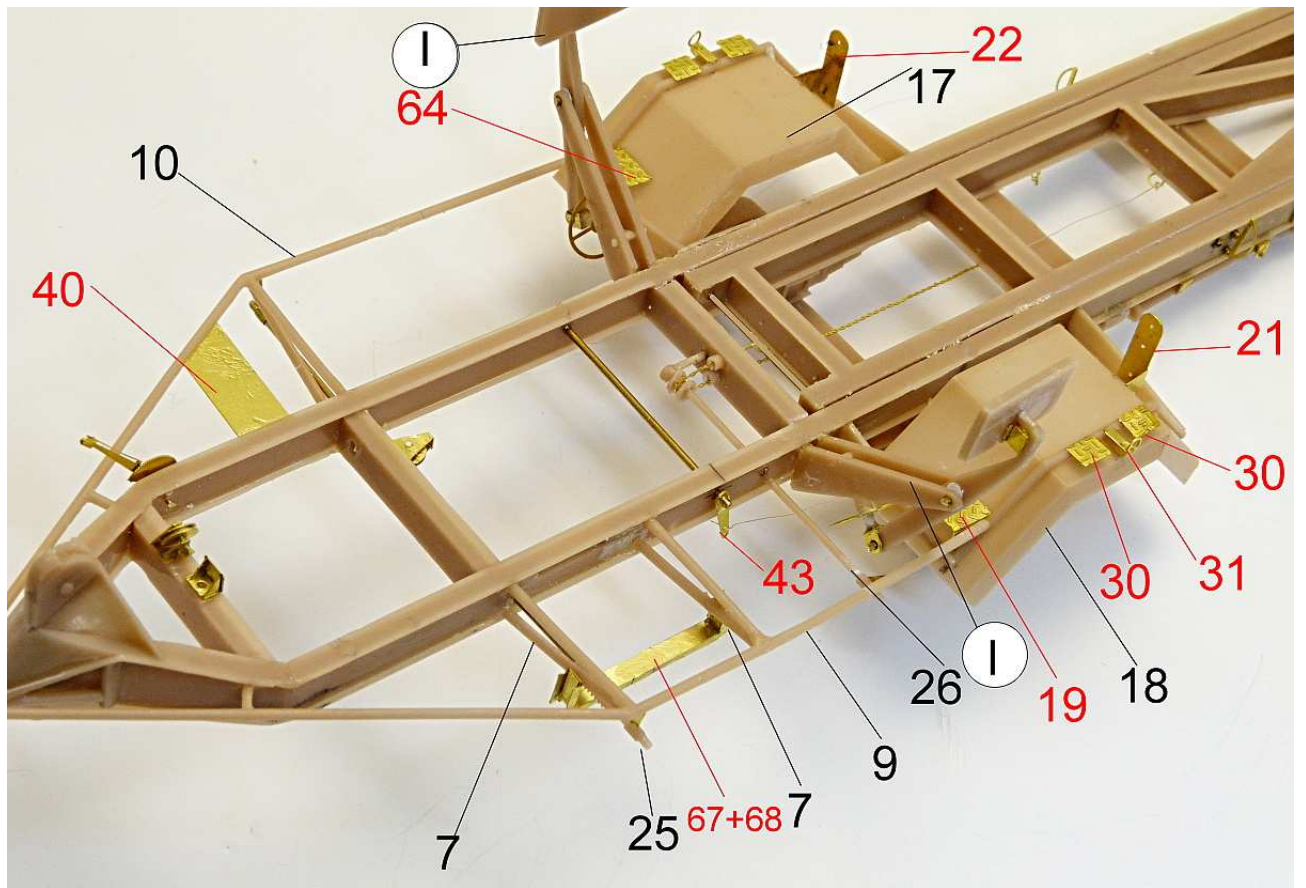

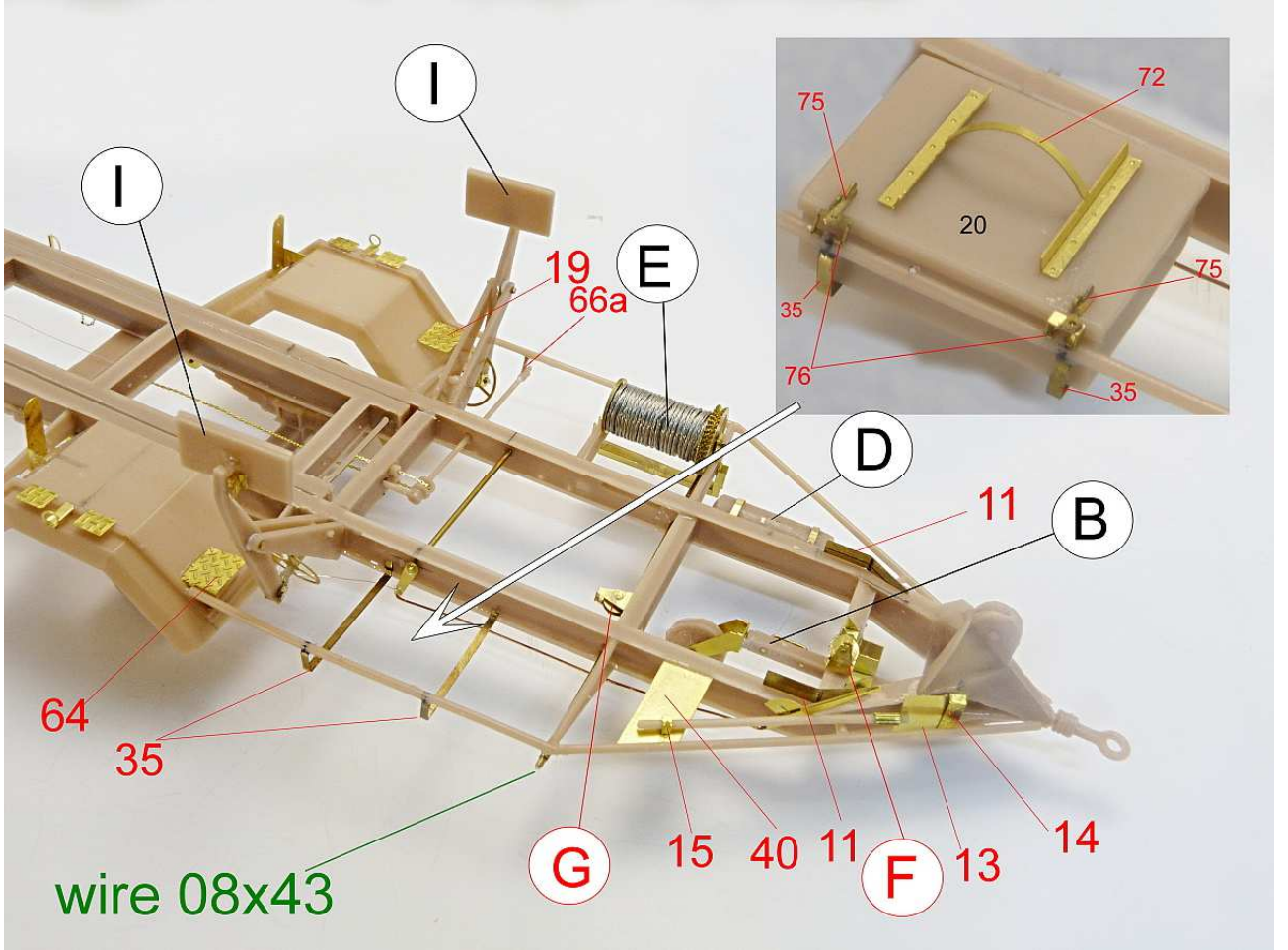
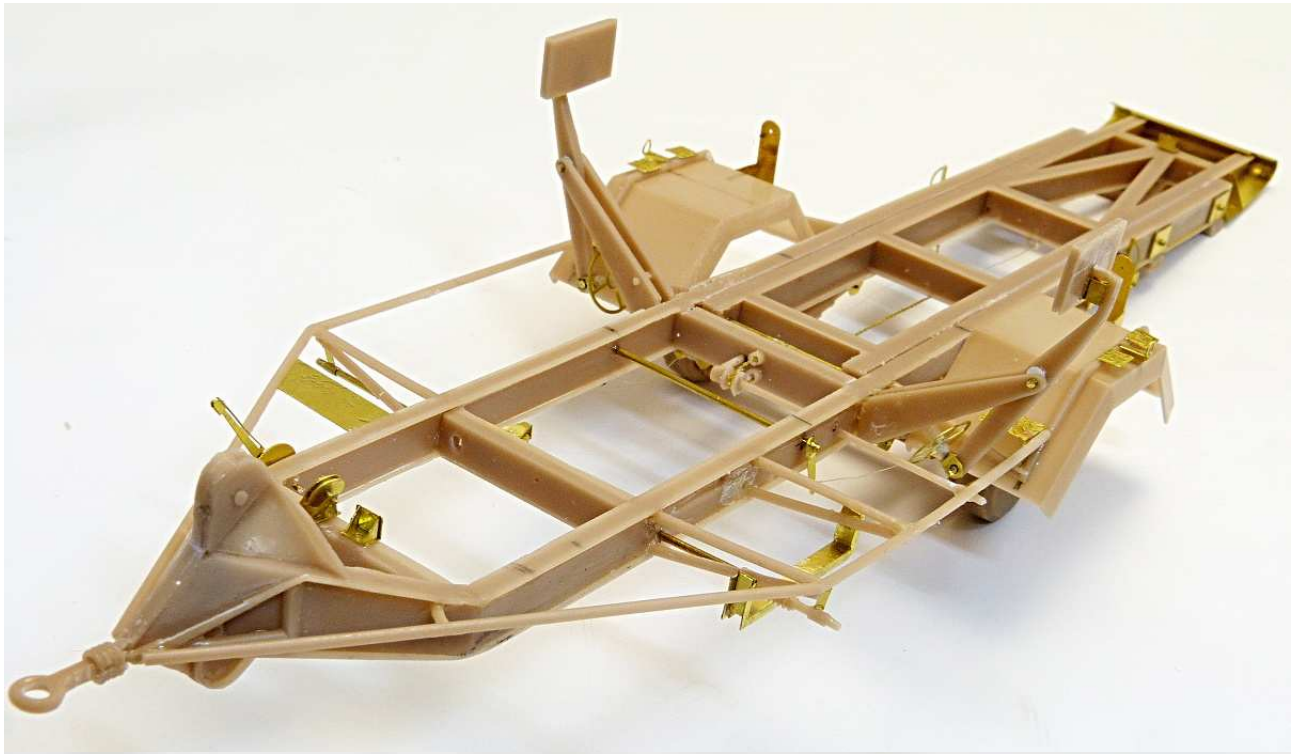

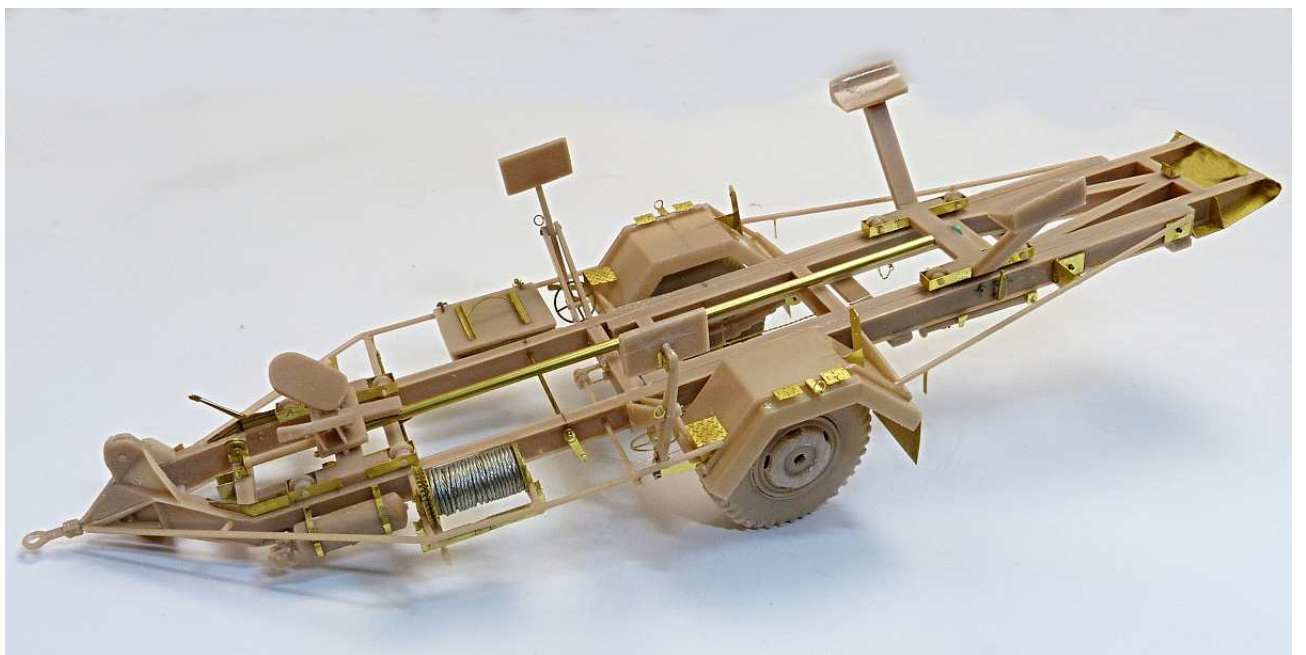
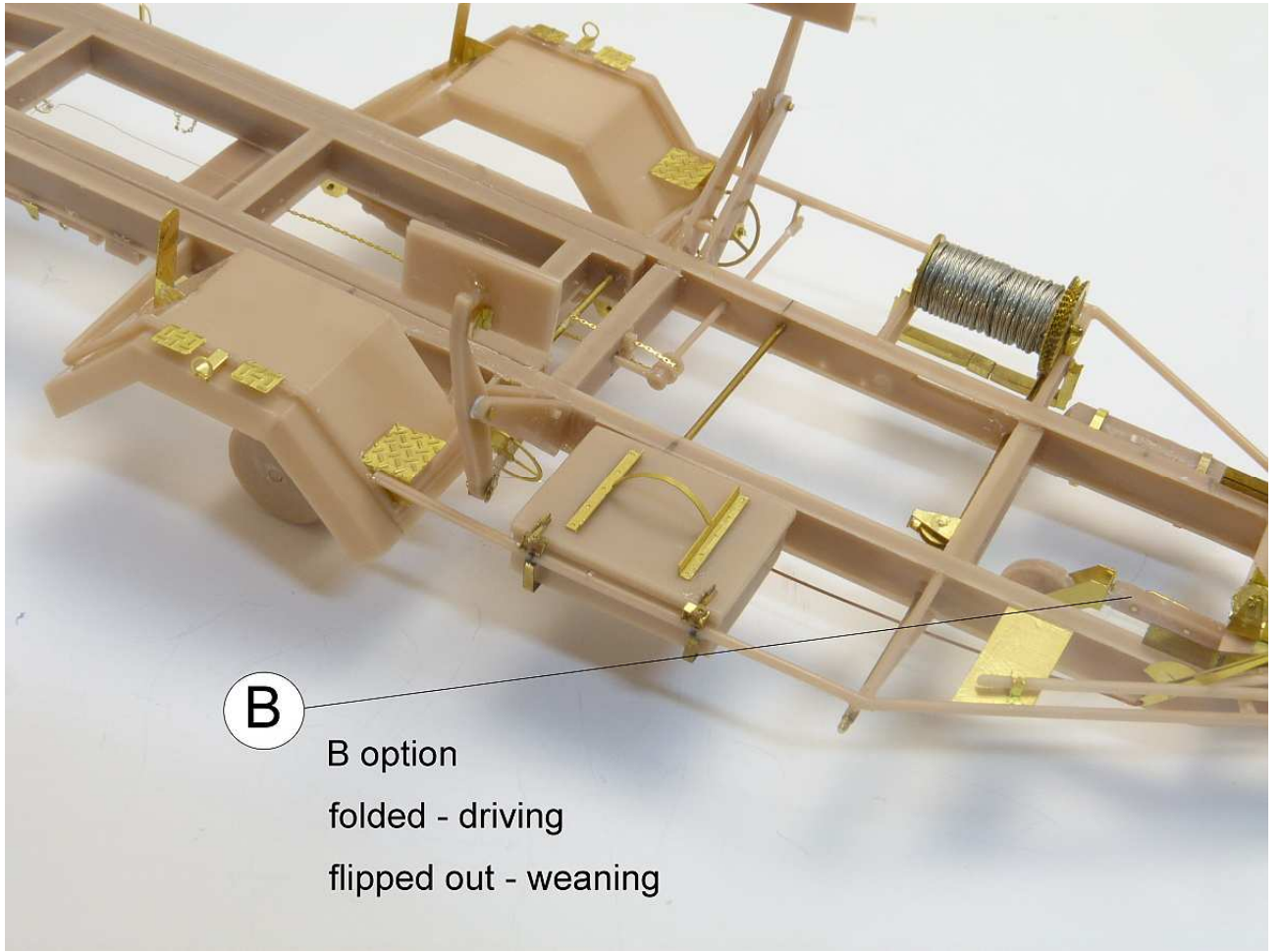



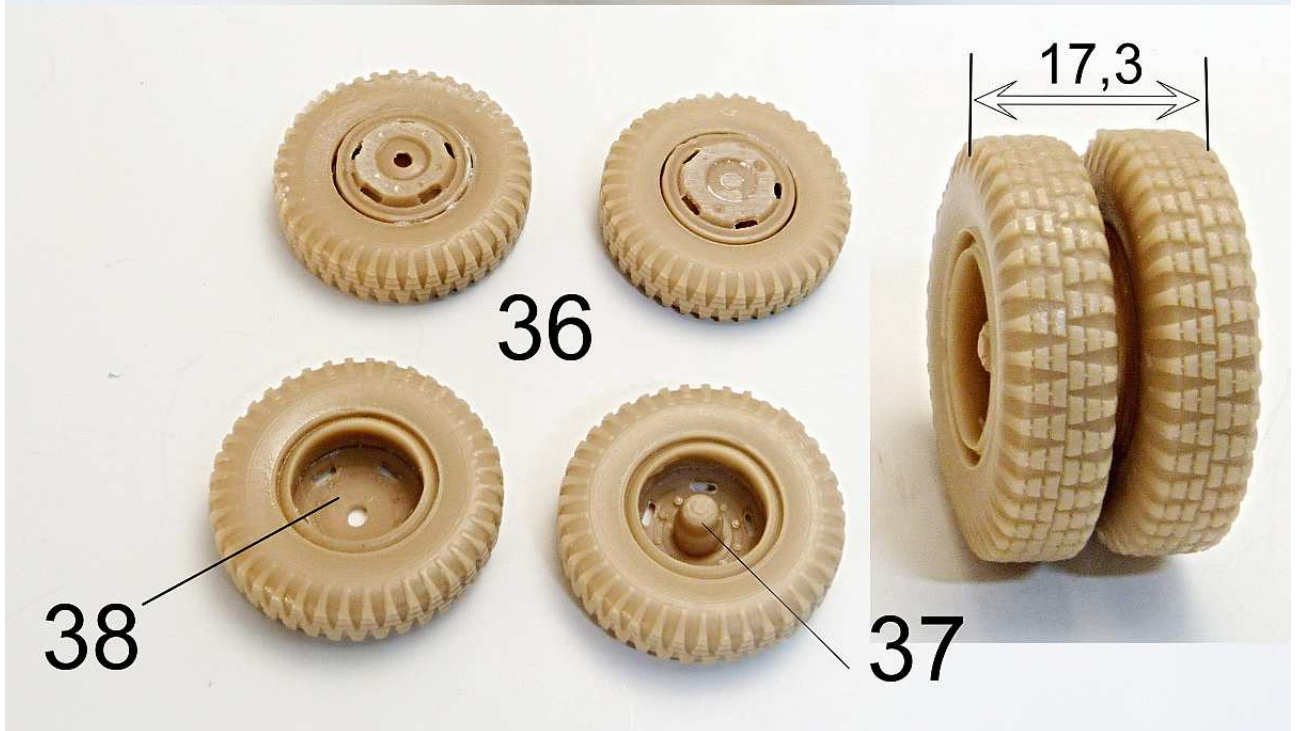
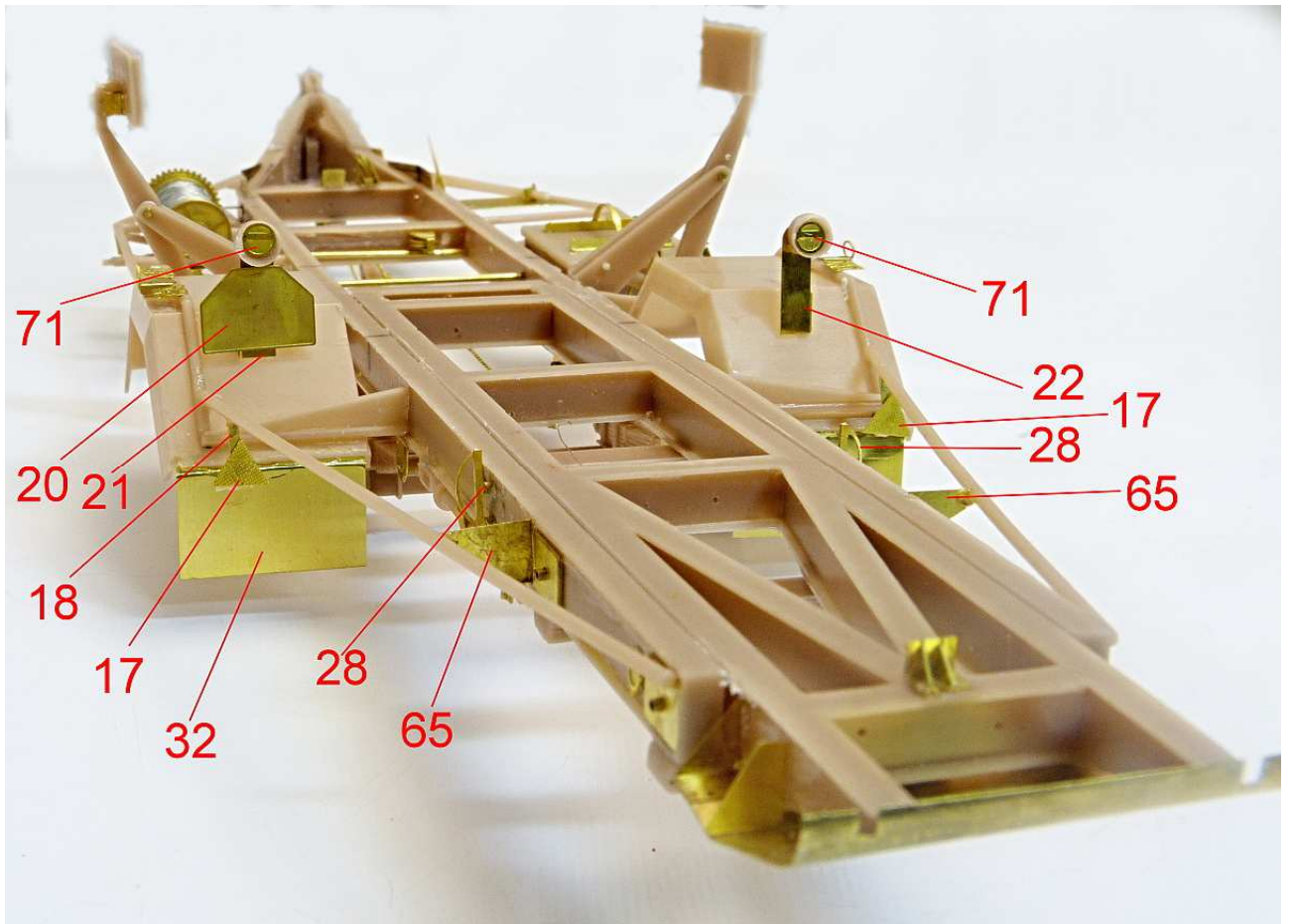

Recommended attachment of the boat to the chassis

